



# Beverages Applications Notebook

Functional Waters/Drinks

**Thermo**  
SCIENTIFIC

---

# Table of Contents

---

Index of Analytes.....	3
Introduction to Beverages .....	4
UltiMate 3000 UHPLC <sup>+</sup> Systems .....	5
IC and RFIC Systems.....	6
MS Instruments .....	7
Chromeleon 7 Chromatography Data System Software .....	8
Process Analytical Systems and Software .....	9
Automated Sample Preparation .....	10–11
<b>Analysis of Functional Waters/Drinks .....</b>	<b>12</b>
Determination of Water- and Fat-Soluble Vitamins in Functional Waters by HPLC with UV-PDA Detection .....	13
Determination of Glucosamine in Dietary Supplements Using HPAE-PAD .....	22
Determination of Vitamin B <sub>12</sub> in Beverages Using On-Line SPE Followed by HPLC with UV Detection .....	31
<b>Column Selection Guide .....</b>	<b>42</b>
Column Selection Guide and Specifications.....	43

---

# Index of Analytes

---

Glucosamine .....	22
Vitamin B <sub>12</sub> .....	31
Vitamins .....	13

## Introduction to Beverages

The global beverage industry is growing each year with the introduction of new products, such as vitamin-fortified water, energy drinks, anti-aging water, and herbal nutritional supplements. With this growth, come many more analytical challenges. These challenges are compounded by the continuing and new needs to analyze classic favorites such as sodas, fruit juices, milk drinks, alcoholic beverages, and bottled water. One such example would be the melamine contamination in milk and infant milk formula.

For all beverages, the compositional quality and safety must be monitored to help track contamination, adulteration, product consistency, and to ensure regulatory compliance from raw ingredients (water, additives, and fruits) to the final product.

Thermo Fisher Scientific is a recognized leader in providing analytical solutions for sample preparation, liquid chromatography for compositional testing, and chromatography data management for compliance and quality testing of beverages. From inorganic ions, organic acids, biogenic amines, glycols and alcohols,

carbohydrates and sugar alcohols, to vitamins, additives, and sugar substitutes, we are unique in our commitment to provide fast, accurate testing and labeling information for all applications in this industry.

### *Thermo Scientific and Dionex Integrated Systems*

Dionex Products are now a part of the Thermo Scientific brand, creating exciting new possibilities for scientific analysis. Now, leading capabilities in liquid chromatography (LC), ion chromatography (IC), and sample preparation are together in one portfolio with those in mass spectrometry (MS). Combining Dionex's leadership in chromatography with Thermo Scientific's leadership position in mass spec, a new range of powerful and simplified workflow solutions now becomes possible.

For more information on how the new lineup of Thermo Scientific products can expand your capabilities and provide the tools for new possibilities, choose one of our integrated solutions:

- Ion Chromatography and Mass Spectrometry
- Liquid Chromatography and Mass Spectrometry
- Sample Preparation and Mass Spectrometry

## UltiMate 3000 UHPLC<sup>+</sup> Systems

### *Best-in-class HPLC systems for all your chromatography needs*

Thermo Scientific Dionex UltiMate 3000 UHPLC<sup>+</sup> Systems provide excellent chromatographic performance while maintaining easy, reliable operation. The basic and standard analytical systems offer ultra HPLC (UHPLC) compatibility across all modules, ensuring maximum performance for all users and all laboratories. Covering flow rates from 20 nL/min to 10 mL/min with an industry-leading range of pumping, sampling, and detection modules, UltiMate™ 3000 UHPLC<sup>+</sup> Systems provide solutions from nano to semipreparative, from conventional LC to UHPLC.

- Superior chromatographic performance
- UHPLC design philosophy throughout nano, standard analytical, and rapid separation liquid chromatography (RSLC)
- 620 bar (9,000 psi) and 100 Hz data rate set a new benchmark for basic and standard analytical systems
- RSLC systems go up to 1000 bar and data rates up to 200 Hz
- ×2 Dual System for increased productivity solutions in routine analysis
- Fully UHPLC compatible advanced chromatographic techniques

- Thermo Scientific Dionex Viper and nanoViper—the first truly universal, fingertight fitting system even at UHPLC pressures

Thermo Fisher Scientific is the only HPLC company uniquely focused on making UHPLC technology available to all users, all laboratories, and for all analytes.

*Rapid Separation LC Systems:* The extended flow-pressure footprint of the RSLC system provides the performance for ultrafast high-resolution and conventional LC applications.

*RSLCnano Systems:* The Rapid Separation nano LC System (RSLCnano) provides the power for high-resolution and fast chromatography in nano, capillary, and micro LC.

*Standard LC Systems:* Choose from a wide variety of standard LC systems for demanding LC applications at nano, capillary, micro, analytical, and semipreparative flow rates.

*Basic LC Systems:* UltiMate 3000 Basic LC Systems are UHPLC compatible and provide reliable, high-performance solutions to fit your bench space and your budget.



## IC and RFIC Systems

### *A complete range of ion chromatography solutions for all customer performance and price requirements*

For ion analysis, nothing compares to a Thermo Fisher Scientific ion chromatography system. Whether you have just a few samples or a heavy workload, whether your analytical task is simple or challenging, we have a solution to match your needs and budget. And with your IC purchase, you get more than just an instrument—you get a complete solution based on modern technology and world-class support.

- Thermo Scientific Dionex ICS-5000: The world's first capillary IC system
- Dionex ICS-2100: Award-winning integrated Reagent-Free™ IC system
- Dionex ICS-1600: Standard integrated IC system
- Dionex ICS-1100: Basic integrated IC system
- Dionex ICS-900: Starter line IC system

Ranging from the Dionex ICS-900 to the ICS-5000, these IC systems cover the entire range of IC needs and budgets and come with superior support and service worldwide.

*Dionex ICS-5000:* Developed with flexibility, modularity, and ease-of-use in mind, the Dionex ICS-5000 combines the highest sensitivity with convenience

*Dionex ICS-2100:* An integrated Reagent-Free IC (RFIC™) system for electrolytically generated isocratic and gradient separations with conductivity detection, now with electrolytic sample preparation.

*Dionex ICS-1600:* The Dionex ICS-1600 combines high sensitivity with convenience. Now ready for eluent regeneration, with available dual-valve configuration for automated sample preparation.

*Dionex ICS-1100:* With dual-piston pumping and electrolytic suppression. Now ready for eluent regeneration, with available dual-valve configuration for automated sample preparation.

*Dionex ICS-900:* Can routinely analyze multiple anions and cations in 10–15 min—fully automated with Displacement Chemical Regeneration (DCR).



## MS Instruments

### *Single-point control and automation for improved ease-of-use in LC/MS and IC/MS*

Thermo Fisher Scientific provides advanced integrated IC/MS and LC/MS solutions with superior ease-of-use and modest price and space requirements. UltiMate 3000 System Wellness technology and automatic MS calibration allow continuous operation with minimal maintenance. The Dionex ICS-5000 instrument and the family of RFIC systems automatically remove mobile phase ions for effort-free transition to MS detection.

- Thermo Scientific MSQ Plus mass spectrometer, the smallest and most sensitive single quadrupole on the market for LC and IC
- Self-cleaning ion source for low-maintenance operation

- Thermo Scientific Dionex Chromeleon Chromatography Data System software for single-point method setup, instrument control, and data management
- Compatible with existing IC and LC methods
- The complete system includes the MSQ Plus™ mass spectrometer, PC datasystem, electrospray ionization (ESI) and atmospheric pressure chemical ionization (APCI) probe inlets, and vacuum system

You no longer need two software packages to operate your LC/MS system. Chromeleon™ LC/MS software provides single-software method setup and instrument control; powerful UV, conductivity, and MS data analysis; and fully integrated reporting.

*MS Systems and Modules:* MSQ Plus Mass Spectrometer; MSQ18LA nitrogen gas generator; Thermo Scientific Dionex AXP-MS digital auxiliary pump



# Chromeleon 7 Chromatography Data System Software

## *The fastest way to get from samples to results*

Discover Chromeleon software version 7, the chromatography software that streamlines your path from samples to results. Get rich, intelligent functionality and outstanding usability at the same time with Chromeleon software version 7—the Simply Intelligent™ chromatography software.

- Enjoy a modern, intuitive user interface designed around the principle of operational simplicity
- Streamline laboratory processes and eliminate errors with eWorkflows, which enable anyone to perform a complete analysis perfectly with just a few clicks
- Access your instruments, data, and eWorkflows instantly in the Chromeleon Console
- Locate and collate results quickly and easily using powerful built-in database query features
- Interpret multiple chromatograms at a glance using MiniPlots
- Find everything you need to view, analyze, and report data in the Chromatography Studio

- Accelerate analyses and learn more from your data through dynamic, interactive displays
- Deliver customized reports using the built-in Excel-compatible spreadsheet

Chromeleon software version 7 is a forward-looking solution to your long-term chromatography data needs. It is developed using the most modern software tools and technologies, and innovative features will continue to be added for many years to come.

The Cobra™ integration wizard uses an advanced mathematical algorithm to define peaks. This ensures that noise and shifting baselines are no longer a challenge in difficult chromatograms. When peaks are not fully resolved, the SmartPeaks™ integration assistant visually displays integration options. Once a treatment is selected, the appropriate parameters are automatically included in the processing method.

Chromeleon software version 7 ensures data integrity and reliability with a suite of compliance tools. Compliance tools provide sophisticated user management, protected database structures, and a detailed interactive audit trail and versioning system.





## Process Analytical Systems and Software

### *Improve your process by improving your process monitoring with a Thermo Scientific Dionex on-line IC or HPLC system*

Our process analytical systems provide timely results by moving liquid chromatography-based measurements on-line. Information from the Thermo Scientific Dionex Integral process analyzer can help reduce process variability, improve efficiency, and reduce downtime. These systems provide comprehensive, precise, accurate information faster than is possible with laboratory-based results. From the lab to the factory floor, your plant's performance will benefit from the information provided by on-line LC.

- Characterize your samples completely with multicomponent analysis
- Reduce sample collection time and resources with automated multipoint sampling
- Improve your process control with more timely results

- See more analytes with unique detection capabilities
- 25 years of experience providing on-line IC and HPLC capabilities to a wide range of industries
- The Thermo Scientific Integral Migration Path approach lets you choose the systems that best meets your needs

The Integral Migration Path™ approach enables on-line IC/HPLC to generate timely, high-resolution information when monitoring a small-scale reactor in a process R&D lab, in a pilot plant, or improving current manufacturing plant processes. No matter what the application, the Integral™ process analyzer has the versatility to place a solution using on-line IC/HPLC, whenever and wherever it is needed.

*Integral:* The Integral Migration Path approach: System solutions wherever you need them: lab, pilot plant, or manufacturing

*Chromeleon Process Analytical (PA) Software:* Chromeleon PA software provides unique capabilities to support on-line IC or HPLC analysis



## Automated Sample Preparation

### ***ACCELERATED SOLVENT EXTRACTORS***

#### ***Two new solvent extraction systems with pH-hardened Dionium components***

We offer two solvent extraction systems. The Thermo Scientific Dionex ASE 150 Accelerated Solvent Extractor is an entry-level system with a single extraction cell, for

laboratories with modest throughput. The Dionex ASE™ 350 system is a sequential extraction system capable of automated extraction of up to 24 samples. Both systems feature chemically inert Dionium components that allow the extraction of acid- or base-pretreated samples.



## **SOLID-PHASE EXTRACTION SYSTEMS**

*Faster, more reliable solid-phase extraction while using less solvent*

The Thermo Scientific Dionex AutoTrace 280 Solid-Phase Extraction (SPE) instrument unit can process six samples simultaneously with minimal intervention. The instrument uses powerful pumps and positive pressure with constant flow-rate technology. Current analytical methods that require SPE sample preparation include gas chromatography (GC), GC-MS, LC, and LC-MS, IC and IC-MS. The Dionex AutoTrace™ 280 instrument is approved or adapted for U.S. EPA clean water methods and safe drinking water methods (600 and 500 series) and can extract the following analytes:

- PCBs (polychlorinated biphenyls)
- OPPs (organophosphorus pesticides), OCPs (organochlorine pesticides), and chlorinated herbicides

- BNAs (base, neutral, acid semivolatiles)
- Dioxins and furans
- PAHs (polyaromatic hydrocarbons)
- Oil and grease or hexane extractable material

With SPE, large volumes of liquid sample are passed through the system and the compounds of interest are trapped on SPE adsorbents (cartridge or disk format), then eluted with strong solvents to generate an extract ready for analysis. Automated SPE saves time, solvent, and labor for analytical laboratories.

*Dionex AutoTrace Systems:* The new Dionex AutoTrace 280 system provides fast and reliable automated solid phase extraction for organic pollutants from liquid samples

*Dionex AutoTrace Accessories:* High-quality parts and accessories are available for Dionex AutoTrace 280 instruments



---

## Analysis of Functional Waters/Drinks

---



# Determination of Water- and Fat-Soluble Vitamins in Functional Waters by HPLC with UV-PDA Detection

## **INTRODUCTION**

Functional beverages are vitamin-enhanced waters that have gained consumer popularity for convenience, perceived health benefits, and improved flavor over tap water. These beverages are typically enriched with Vitamin C, B-complex vitamins, and Vitamins A and E, with the advertised benefits of increased energy from the B vitamins and antioxidant benefits from Vitamins A, C, and E. Industry forecasts predict the sales of these beverages to increase to 4,388.9 million liters per year by 2011.<sup>1</sup>

Labeling the nutritional content of these beverages is regulated by the U.S. Food and Drug Administration (US FDA). Therefore, methods are needed to assay the vitamins to support product labeling. Determination of vitamins in foods is inherently difficult and deviation of the determined amounts of a vitamin from labeled amounts has been observed.<sup>2</sup> Analysis of these beverages presents a challenge due to the presence of both water- and fat-soluble vitamins. Proprietary formulations of vitamins that remain soluble and shelf-stable are used to enrich these beverages. Additionally, gums, preservatives, and other additives are used to emulsify and stabilize the drink.

Traditional analysis of vitamin products requires several different methods to quantify the additives. Water-soluble vitamins are often determined with RP-HPLC using an aqueous mobile phase, while the fat-soluble vitamins use organic solvent mobile phases in both reversed and normal-phase HPLC methods.<sup>3</sup> Combined methods evaluating both types of vitamins pose a challenge due to the difference in solubility limits of the two classes of vitamins and the many different biologically equivalent compounds that can be added, but are listed as a single vitamin. For example, niacin is available as nicotinic acid and nicotinamide, which are both biologically active and referred to as niacin in product labeling.

The simultaneous determination of a wide range of vitamins increases the complexity of an analytical method. Vitamin structures range from small unconjugated organic acids, such as pantothenic acid (Vitamin B5) that are minimally UV active, to large complexes that absorb at different wavelengths, such as cyanocobalamin (Vitamin B12). Multiple detection wavelengths are needed to optimize sensitivity due to the chemical diversity of vitamins.

In this application note, an Acclaim® PolarAdvantage II column is used to determine water- and fat-soluble vitamins in a single method. This column contains a high-efficiency, silica-based, polar-embedded stationary phase manufactured by bonding a proprietary amide-embedded ligand to high-purity spherical silica. It is compatible with 100% aqueous mobile phases over a wide pH range (1.5–10), and provides excellent peak shapes and efficiencies for both basic and acidic compounds. The gradient method in this application uses the aqueous compatibility of this column by beginning with a 100% aqueous mobile phase and ending with a 100% organic solvent mobile phase. Linearity, detection limits, precision, and recovery are demonstrated. This method provides a rapid means of analyzing a sample for both water- and fat-soluble vitamins in a single injection using a low flow rate that minimizes mobile phase preparation time and reduces waste.

#### **EQUIPMENT**

Dionex UltiMate® 3000 Intelligent LC system:

SRD-3200 Solvent Rack (Dionex P/N 5035.9250)

HPG-3200M pump (Dionex P/N 5035.0018)

WPS-3000TSL Micro Autosampler  
(Dionex P/N 5822.0025)

Sample Loop, 25 µL (Dionex P/N 6820.2415)

TCC-3200 column compartment  
(Dionex P/N 5722.0025)

PDA-3000 detector (Dionex P/N 5080.0020)

Semi-Micro PEEK™ flow cell, 3 µL  
(Dionex P/N 064169)

Chromeleon 6.8 Chromatography Data System

Glass injection vials with caps and septa, 1.5 mL  
(Dionex P/N 055427)

Nalgene® Filter Unit, 0.2 µm nylon membrane,  
1L capacity (Nalgene P/N 164-0020)

#### **REAGENTS AND STANDARDS**

Deionized water, Type I reagent grade, 18 MΩ-cm resistivity or better

Formic Acid, puriss. p.a. grade or better  
(Fluka P/N 06440)

Acetonitrile, HPLC grade or better (B&J P/N 015-4)

Methanol, HPLC grade or better (B&J P/N 230-4)

Folic Acid (AccuStandard P/N VIT-0007N)

Vitamin B6 as Pyridoxine-HCl  
(AccuStandard P/N VIT-003N)

Vitamin E as DL-α-Tocopherol Acetate  
(AccuStandard P/N VIT-015N)

Vitamin A as Retinol Palmitate  
(AccuStandard P/N VIT-014N)

Niacin as Nicotinic Acid (AccuStandard P/N VIT-005N)

Niacin as Nicotinamide (AccuStandard P/N VIT-006N)

Vitamin B5 as D-Pantothenic Acid  
(AccuStandard P/N VIT-008N)

Vitamin C as Ascorbic Acid  
(AccuStandard P/N VIT-004N)

Vitamin B12 as Cyanocobalamine  
(AccuStandard P/N VIT-010N-R1)

#### **Samples**

Three fruit-flavored vitamin-enhanced beverages (Labeled Brands A, B, and C) were analyzed for vitamin content. Samples were diluted 1:1 with 0.015% formic acid prior to analysis. The ingredients are listed in Table 1.

**Table 1. Ingredients in Vitamin-Enhanced Functional Beverages**

Brand A	Brand B	Brand C
water	water	purified water
sucrose syrup	cane sugar	sugar
citric acid	crystalline fructose	citric acid
natural flavors	natural flavors	natural flavors
sodium citrate	citric acid	potassium citrate
potassium citrate	ascorbic acid (vitamin C)	calcium lactate
sucralose	vitamin E acetate	calcium gluconate
vitamin C	fruit and vegetable juice (color)	magnesium lactate
vitamin E acetate	magnesium lactate	modified corn starch
niacinamide	calcium lactate	ginseng extract
calcium disodium EDTA	niacin	caffeine
calcium pantothenate	monopotassium phosphate	guarana seed extract
pyridoxine hydrochloride	pantothenic acid	vegetable juices (color)
acesulfame potassium	pyridoxine hydrochloride	acacia gum
vitamin B12	vitamin B12	calcium disodium EDTA
	folic acid	ribose
		niacinamide
		vitamin E acetate
		calcium pantothenate
		zinc gluconate
		pyridoxine hydrochloride
		manganese gluconate
		EGCG (epigallocatechin gallate)
		vitamin A palmitate
		vitamin B12

**CONDITIONS**

Column: Acclaim PolarAdvantage II 3  $\mu$ m, 2.1  $\times$  150 mm (Dionex P/N 063187)

Gradient: Mobile Phase A:  
0.015% Formic Acid in DI water  
Mobile Phase B:  
17/83 Methanol/Acetonitrile  
100% A for 3 min, 0-45% B in 5 min, 45-100% B in 0.1 min, 100% B for 16.9, 5 min of equilibration at 100% A prior to injection

Flow Rate: 0.21 mL/min

Temperature: 40 °C (column compartment)

Inj. Volume: 5  $\mu$ L

Detection: Photodiode Array; 210, 280, and 350 nm

Noise: ~0.28 mAU at 210 nm

~0.12 mAU at 280 nm and 350 nm

**System**

Backpressure: ~1120 psi at 100% A, 510 psi at 100% B

**PREPARATION OF SOLUTIONS AND REAGENTS**

**Mobile Phase A (0.015% Formic Acid)**

To prepare this solution, measure 2 L (2000 g) of DI water in a 2 L glass eluent bottle. Using a 1 mL graduated pipet, add 0.30 mL of formic acid to the water. Mix well and briefly degas the solution.

**Mobile Phase B (17/83 methanol/acetonitrile)**

To prepare this solution, transfer 340 mL methanol into a 2 L volumetric flask. Bring to volume with acetonitrile. Mix well. Do not adjust the volume of solution after mixing. Transfer the solution to a 2 L glass eluent bottle and briefly degas the solution.

### Water-Soluble Vitamin Standards

Vitamin standards of pyridoxine HCl, nicotinic acid, nicotinamide, D-pantothenic acid, and cyanocobalamin were prepared by accurately weighing 10–20 mg of the vitamin powder and adding DI water to a total of 10–20 g to form a stock solution of 1.0 mg/mL for each individual vitamin. Due to the limited stability of ascorbic acid, a stock solution of 2.0 mg/mL was freshly prepared weekly. Folic acid is not soluble in water as the free acid. To convert the vitamin to folate, 5 mg of folic acid were dispersed in 4 mL of DI water with a minimum amount of 0.45% potassium hydroxide added to convert the folic acid to potassium folate. This solution was then diluted with DI water to yield a total volume of 5 mL (5 g) to form a solution of 1.0 mg/mL folic acid as potassium folate. Water-soluble vitamin stock solutions were stored at -20 °C when not in use. Working standards containing vitamins in 0.015% formic acid (mobile phase A) were prepared on the day of use from these stock solutions.

### Fat-Soluble Vitamin Standards

The fat-soluble vitamins were prepared in acetonitrile by weighing 10 mg of DL- $\alpha$ -tocopherol acetate and 2.0 mg of retinol palmitate, respectively, in separate 20 mL glass vials. Acetonitrile was added to yield a 1 mg/mL solution of DL- $\alpha$ -tocopherol acetate and a 0.2 mg/mL solution of retinol palmitate. Retinol palmitate requires several minutes of vortex mixing to dissolve. These solutions were stored at 4 °C in the dark. Stock solutions were allowed to equilibrate at room temperature and mixed using a vortex mixer to ensure that the oils were thoroughly dissolved before being used to make working standards. Retinol palmitate is photosensitive and should be protected from light.

Calibration standards of retinol palmitate and DL- $\alpha$ -tocopherol acetate were not prepared in a matrix of 0.015% formic acid. Instead, due to solubility limitations, working standards of these vitamins were prepared in mobile phase B from stock solutions prepared in acetonitrile and determined separately from the water-soluble vitamins. Retinol palmitate is difficult to prepare as an aqueous solution. Many fat-soluble vitamins are available as water miscible or soluble formulations; however, commercially available standards were used to evaluate this method. In this case, solubility of the fat-

soluble vitamins, when added to a water-soluble vitamin mixture, was limited. For this reason, a separate standard curve was prepared for the fat-soluble vitamins in mobile phase B.

### Sample Preparation

Fruit-flavored vitamin-enhanced water samples were prepared by diluting 500  $\mu$ L sample beverage with 500  $\mu$ L of mobile phase A. For reference, the ingredients in these enhanced water samples are listed in Table 1.

### Precautions

Sample filtration is not recommended due to adsorption of the fat-soluble vitamins to plastic surfaces. Filtration was shown to remove these vitamins from solution.

The solubility of the fat-soluble vitamins in methanol-acetonitrile mixtures was assessed. The best solubility of Vitamin A was found in acetonitrile. Mixtures with methanol decreased the apparent solubility of Vitamin A, as retinol palmitate.

The autosampler tray should be maintained at 4 °C and the use of the tray shake option is recommended to ensure sample homogeneity during the runs.

## RESULTS AND DISCUSSION

### Separation and Detection

Figure 1 demonstrates separation of water- and fat-soluble vitamins in a single run using an Acclaim Polar Advantage II column. Sodium citrate and citric acid, which are common ingredients to enhance tartness, were added to the mixture to demonstrate the separation between nicotinamide and citrate. As shown in Figure 1, citrate and the vitamins are well separated. Vitamins are a structurally diverse group of compounds with different absorbance maxima. For example; retinol palmitate has a strong absorption at 350 nm, while D-pantothenic acid absorbs best in the UV range between 200 and 225 nm. Given the wide UV absorbance range for the vitamins commonly added to enhanced waters, wavelengths of 210, 280, and 350 nm were chosen for detection. In Figure 1, the chromatogram collected at 210 nm captures each of the vitamins except for Vitamin A. Additionally, many smaller acids, including formic acid, absorb at 210 nm. For this reason, the baseline absorbance shifts during the gradient as the amount of formic acid in the mobile phase changes.



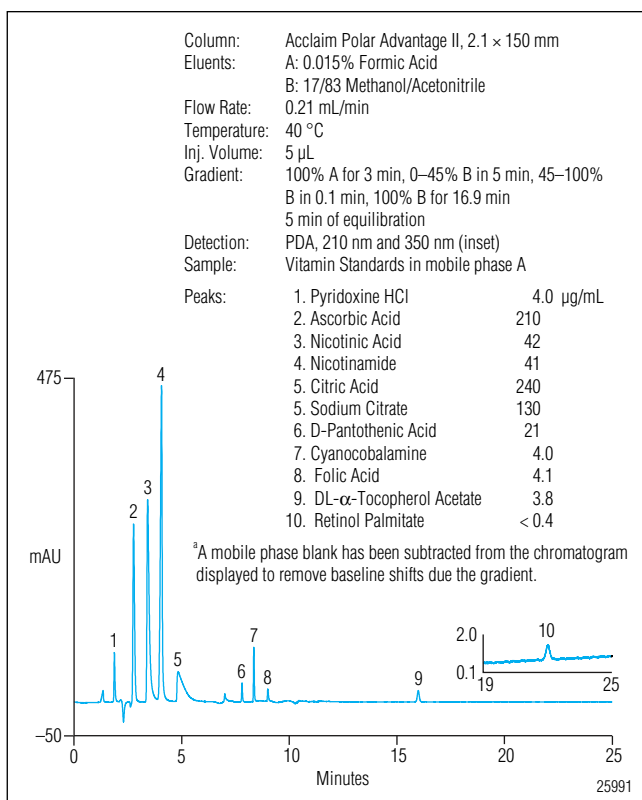

Figure 1. Separation of vitamins on the Acclaim Polar Advantage II column.<sup>a</sup> (citric acid and citrate both contribute to peak 5.)

The chromatograms shown here have had a mobile phase blank subtracted from the raw data to correct the baseline shifts. This action can be automated in Chromeleon by acquiring a system blank before samples and using post-acquisition steps within the acquisition program to subtract the blank, or it can be done manually with the Arithmetic Combination option.

### Linearity, Limit of Detection, and Limit of Quantitation

The linearity, LOD, LOQ, and the precision data for this gradient method were determined for the determination of vitamins (Table 2). With the exception of ascorbic acid, the LOD was determined by the concentration of the analyte that provides a peak height that is three times the measured noise ( $S/N = 3$ ) and the LOQ was determined as the concentration of the analyte that provides a peak height that is ten times the measured noise ( $S/N = 10$ ). The figures of merit for Vitamin B6 are presented for two wavelengths. Detection at 210 nm is convenient; however, it also maximizes the potential for detecting interfering components. Vitamin B6 sensitivity and linearity are equivalent when detecting at 210 or 280 nm. Either wavelength is appropriate, which provides flexibility in optimizing the method for a particular sample. Folic acid can be detected at 210 nm; however, detection is more sensitive at 280 nm.

Table 2. Linearity, LOD, and LOQ of Vitamins Analyzed

Analyte	Detection Wavelength (nm)	Correlation Coefficient ( $r^2$ )	Range (µg/mL)	LOD (ng/mL)	LOQ (ng/mL)	Retention Time Precision (RSD)* n=7	Peak Area Precision (RSD)* n=7
Pyridoxine HCl	210	0.9994	1.0–20	20	60	0.10	0.28
Pyridoxine HCl	280	0.9997	1.0–20	20	60	0.10	0.75
Ascorbic Acid	210	0.9992	15–300	5000	5000	0.07	3.47
Nicotinic Acid	210	0.9995	5.0–100	84	250	0.07	0.40
Nicotinamide	210	0.9995	5.0–100	35	100	0.08	0.54
D-Pantothenic Acid	210	0.9993	5.0–100	213	640	0.23	0.75
Cyanocobalamine	210	0.9995	1.0–20	14	40	0.09	0.83
Folic Acid	280	0.9987	0.25–2.5	20	60	0.16	0.97
DL-α-Tocopherol Acetate	210	0.9985	1.2–25	83	250	0.14	0.77
Retinol Palmitate	350	0.9996	0.63–12	125	400	0.17	0.54

\*Analyte concentrations for precision injections: Pyridine HCl (5 µg/mL), Ascorbic Acid (77 µg/mL), Nicotinic Acid, Nicotinamide, and Pantothenic Acid (25 µg/mL each), Cyanocobalamine (5 µg/mL), Folic Acid (1.3 µg/mL), DL-α-Tocopherol Acetate (6.2 mg/mL), and Retinol Palmitate (1.3 µg/mL)

For ascorbic acid, the value listed in Table 2 is the amount that could be consistently measured when dissolved in a 0.015% formic acid solution without additional preservatives. Ascorbic acid (AA) exists in solution in equilibrium with the oxidation product dehydroascorbic acid (DHAA). While both compounds are biologically active as Vitamin C, DHAA does not have a strong UV absorption and therefore is difficult to quantify. The oxidation reaction is reversible and is minimized at low pH or by adding a reducing agent to prevent oxidation of ascorbic acid by dissolved oxygen.<sup>4</sup> Peak areas for AA concentrations that were <5 µg/mL of were not reproducible due to the rapid oxidation of the sample at low concentrations. Preservation of AA at an acidic pH was not feasible due the presence of folic acid, which precipitates at low pH. While folic acid is classified as a water-soluble vitamin, it is weakly soluble as the protonated organic acid.

### Functional Beverage Samples

Water- and fat-soluble vitamins are determined in fruit-flavored vitamin-enhanced waters as demonstrated in Figures 2 and 3. Brand A is a vitamin-enhanced water that is sweetened with artificial sweeteners (Figure 2). Figure 3 shows results from the analysis of Brand C, an enhanced beverage sweetened with sugar and containing natural extracts and caffeine. This sample is a more complex matrix than Brand A as shown by the large number of unidentified peaks. In both samples, citrate is resolved from nicotinamide and neither sample contains nicotinic acid. A wavelength of 280 nm was chosen for determining Vitamin B6 due to limited interferences at this wavelength relative to detection at 210 nm. As can be seen in Figure 2 and more dramatically in Figure 3, there is coelution of peaks near the retention time of Vitamin B6. Detection at 280 nm does reduce these interfering peaks.

### Precision and Accuracy

As shown in Table 2, retention time precision of the standards is excellent, with RSDs ranging from 0.07 to 0.23. This demonstrates good precision of the gradient using the HPG- 3200M. The compounds that elute during the gradient have only a slight increase in the deviation of the retention times. With the exception of ascorbic acid, peak area precision is excellent with RSDs of <1.0. Due to the equilibrium with DHAA, in the absence of a preservative AA is prone to larger changes in peak area.

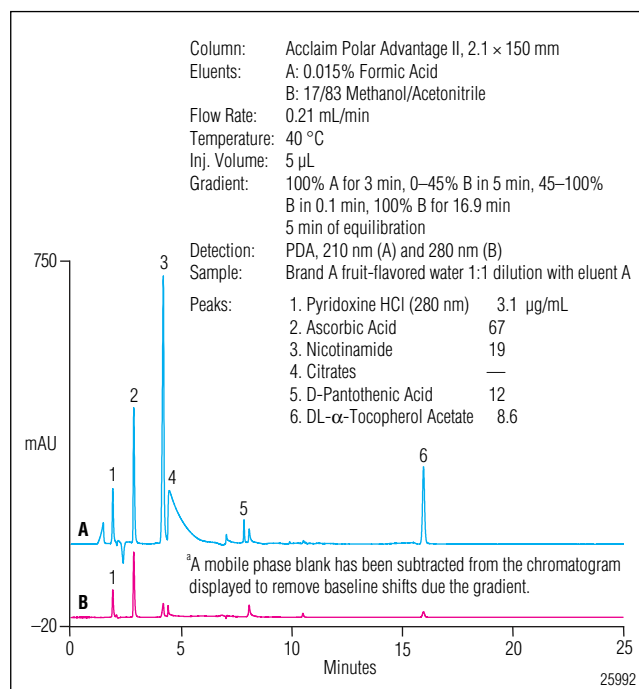

Figure 2. Separation of Brand A, a fruit-flavored, artificially-sweetened, vitamin-enhanced water.<sup>a</sup>

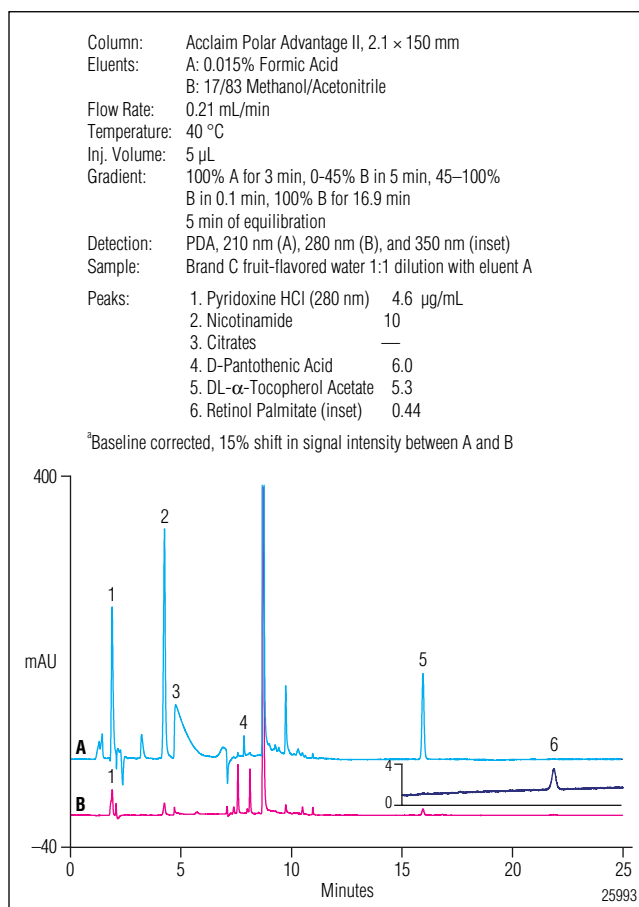

Figure 3. Separation of Brand C, a fruit-flavored, sugar-sweetened, vitamin-enhanced water with added natural extracts and caffeine.<sup>a</sup>

Three brands of vitamin-enhanced water were analyzed over three days to evaluate the precision of the method. Representative data from Brands A, B, and C are presented in Table 3. Summarized data for between day precision for all three samples are in Table 4. Between-day retention time precision ranges from 0.04% and 0.23%, which is equivalent to the precision of the standards. Interday peak area precision ranges from 0.37% to 9.5%. The increased imprecision observed in the folic acid results is due to both the presence of a closely eluting peak present in the Brand B sample and to the low amounts of folic acid present in the sample. While this is a challenging matrix and there is a low concentration of folic acid, it is still easily quantified.

Recoveries (Table 5) for the water soluble vitamins ranged from 93% to 119%. As with precision, the extremes in recoveries were for ascorbic acid and folic acid. Despite the challenges in quantifying these two vitamins, the recoveries are good, proving method accuracy. In this recovery experiment, samples were spiked with folic acid at the lower end of the calibration curve. This concentration of vitamin, while within the linear range for standards, is susceptible to integration error in the beverage matrix due to both potential interfering peaks, and a sloping baseline during the gradient.

Direct spiking of the acetonitrile stocks of Vitamins A and E into vitamin-enhanced waters led to the formation of an unstable suspension. Therefore, a control sample was used to indirectly measure recovery. Use of plastic sample vials exacerbates the removal of fat-soluble vitamins from solution and should be avoided. Recoveries for fat-soluble vitamins were determined by comparison of spiked samples to a control sample of retinol palmitate and DL- $\alpha$ -tocopherol acetate in 0.015% formic acid leading to recovery values ranging between 101%–110%.

As an additional check, the determined values of Vitamin A and Vitamin E were compared to the label claim. Brand A claims to provide 10% of the DV of Vitamin E per serving and Brand B claims 20% of the DV of Vitamin E. In this study, 15% and 25% of Vitamin E were determined in Brands A and B, respectively. Brand C claims 10% each of vitamins A and E. The determined amounts were 10% each, based on FDA guidelines for nutritional labels.<sup>5</sup> In the absence of a formulated aqueous-soluble mixture of the lipophilic vitamins, these results agree well with the label claim and show suitability of the method to determine these vitamins in water.

## CONCLUSION

An Acclaim PolarAdvantage II column was used to determine water- and fat-soluble vitamins in a single injection. The described gradient method uses the full range of eluent compatibility of the Acclaim PA II with 100% aqueous to 100% organic mobile phases. Additionally, these mobile phases are MS compatible, allowing for a complementary detection method. This single-method determination of both water- and fat-soluble vitamins was shown to have good precision, linearity, recovery, and LOQs, making it an excellent method for determination of vitamins in complex aqueous matrixes such as vitamin-enhanced flavored waters.

## LIST OF SUPPLIERS

VWR, 1310 Goshen Parkway, West Chester, PA 19380  
USA. Tel: 800-932-5000. [www.vwr.com](http://www.vwr.com)  
Fisher Scientific, One Liberty Lane, Hampton, NH  
03842 USA. Tel: 800-766-7000, [www.fishersci.com](http://www.fishersci.com)  
Sigma-Aldrich, P.O. Box 14508, St. Louis, MO 63178  
USA. Tel: 800-325-3010. [www.sigma-aldrich.com](http://www.sigma-aldrich.com)  
AccuStandard, Inc. 125 Market Street, New Haven,  
CT 06513 USA Tel: 203-786-5290.  
[www.AccuStandard.com](http://www.AccuStandard.com)

## REFERENCES

- 1) Zegler, Jennifer; State of the Industry-Beverage Blockbusters 2007, Beverage Industry, Feb. 8, 2008. [http://www.bevindustry.com/Archives\\_Davinci?article=2140](http://www.bevindustry.com/Archives_Davinci?article=2140) last accessed 08/04/2008
- 2) Sharpless, Katherine E.; Margolis, Sam; Thomas, Jeanice Brown; Determination of Vitamins in Food-matrix Standard Reference Materials, *J. Chromatogr. A*, **2000**, *881*, 171–181.
- 3) Klimes, J.; Jedlicka, A.; Determination of Water- and Fat-Soluble Vitamins in Different Matrices Using High-Performance Liquid Chromatography, *Chem. Pap.*, **2005**, *59*, 202–222.
- 4) Margolis, Sam A.; Duewer, David L.; Measurement of Ascorbic Acid in Human Plasma and Serum: Stability, Intralaboratory Repeatability, and Interlaboratory Reproducibility, *Clinical Chemistry*, **1996**, *42*, 1257–1262.
- 5) Guidance for Industry – A Food Labeling Guide, U.S. Department of Health and Human Services, Food and Drug Administration, College Park, MD April, 2008 <http://www.cfsan.fda.gov/~dms/2lg-toc.html> last accessed 08/06/08.

<b>Table 3. Sample Analysis Precision, n=3</b>					
<b>Day</b>	<b>Vitamin</b>	<b>Peak Area Precision (RSD)</b>	<b>Retention Time (min)</b>	<b>Retention Time Precision (RSD)</b>	<b>Amount (µg/mL)</b>
<b>Brand A</b>					
1	Pyridoxine HCl	0.32	1.88	0.14	3.1
	Ascorbic Acid	6.1	2.83	0.16	67
	Nicotinamide	0.65	4.17	0.07	19
	D-Pantothenic Acid	0.95	7.83	0.10	12
	Vitamin E	0.74	15.95	0.12	8.6
2	Pyridoxine HCl	1.4	1.88	0.08	3.2
	Ascorbic Acid	0.30	2.83	0.09	72
	Nicotinamide	1.4	4.16	0.10	19
	D-Pantothenic Acid	2.0	7.82	0.12	13
	Vitamin E	0.88	15.94	0.14	8.8
3	Pyridoxine HCl	0.75	1.86	0.06	3.2
	Ascorbic Acid	9.9	2.84	0.04	64
	Nicotinamide	0.57	4.19	0.04	19
	D-Pantothenic Acid	0.91	7.84	0.23	13
	Vitamin E	1.7	15.92	0.10	8.7
<b>Brand B</b>					
1	Pyridoxine HCl	0.89	1.83	0.10	3.2
	Ascorbic Acid	1.2	2.84	0.10	72
	Nicotinamide	0.59	4.27	0.06	9.4
	D-Pantothenic Acid	1.7	7.83	0.18	5.1
	Folic Acid	1.3	9.12	0.19	0.25
	Vitamin E	1.3	15.94	0.12	15
2	Pyridoxine HCl	0.98	1.82	0.11	3.2
	Ascorbic Acid	1.2	2.84	0.07	72
	Nicotinamide	1.0	4.26	0.06	9.4
	D-Pantothenic Acid	1.1	7.82	0.19	5.0
	Folic Acid	2.3	9.10	0.08	0.24
	Vitamin E	0.65	15.93	0.14	15
3	Pyridoxine HCl	0.47	1.81	0.06	3.2
	Ascorbic Acid	0.42	2.85	0.04	61
	Nicotinamide	0.53	4.25	0.05	9.7
	D-Pantothenic Acid	3.46	7.83	0.20	4.8
	Folic Acid	1.5	9.15	0.08	0.21
	Vitamin E	1.1	15.90	0.11	14
<b>Brand C</b>					
1	Pyridoxine HCl	0.47	1.86	0.13	2.2
	Nicotinamide	1.27	4.24	0.02	10
	D-Pantothenic Acid	0.79	7.82	0.17	6.0
	Vitamin E (dl-alpha-tocopherol acetate)	1.21	15.94	0.14	5.3
	Vitamin A (retinol palmitate)	1.56	21.86	0.19	0.44
2	Pyridoxine HCl	0.55	1.87	0.11	2.3
	Nicotinamide	0.62	4.24	<0.01	10
	D-Pantothenic Acid	0.58	7.83	0.16	6.0
	Vitamin E (dl-alpha-tocopherol acetate)	1.59	15.95	0.12	5.4
	Vitamin A (retinol palmitate)	2.07	21.88	0.12	0.43
3	Pyridoxine HCl	1.26	1.84	0.10	2.4
	Nicotinamide	0.42	4.23	0.06	10
	D-Pantothenic Acid	0.66	7.84	0.18	5.9
	Vitamin E (dl-alpha-tocopherol acetate)	2.20	15.92	0.14	5.3
	Vitamin A (retinol palmitate)	3.87	21.81	0.12	0.46

<b>Table 4. Between-Day Precision (n=3)</b>			
<b>Sample</b>	<b>Vitamin</b>	<b>Interday Average Amount (µg/mL)</b>	<b>Interday Precision (RSD)</b>
Brand A	Pyridoxine HCl	3.2	1.16
	Ascorbic Acid	68	6.52
	Nicotinamide	19	1.02
	D-Pantothenic Acid	13	3.38
	Vitamin E	8.7	1.01
Brand B	Pyridoxine HCl	3.2	0.72
	Ascorbic Acid	71	9.3
	Nicotinamide	9.5	1.75
	D-Pantothenic Acid	5.0	2.73
	Folic Acid	0.24	9.52
	Vitamin E	15	0.37
Brand C	Pyridoxine HCl	2.3	4.58
	Nicotinamide	10	0.76
	D-Pantothenic Acid	6.0	0.61
	Vitamin E	5.3	1.39
	Retinol Palmitate	0.44	4.11

<b>Table 5. Recovery Values for Vitamins</b>				
<b>Sample</b>	<b>Vitamin</b>	<b>Amount found in sample (µg/mL)</b>	<b>Amount added (µg/mL)</b>	<b>% Recovery</b>
Brand A	Pyridoxine HCl	3.1	7.6	103
	Ascorbic Acid	66	250	119
	Nicotinic acid	<LOD	7.5	99
	Nicotinamide	19	7.5	106
	D-Pantothenic Acid	12	5.0	110
	Cyanocobalamine	<LOD	1.0	93
	Folic Acid	<LOD	0.25	118
	Vitamin E	8.6	7.9	*
	Retinol Palmitate	<LOD	1.0	*
	Brand B	Pyridoxine HCl	3.2	7.6
Ascorbic Acid		72	250	118
Nicotinic Acid		<LOD	7.5	101
Nicotinamide		9.4	7.5	115
D-Pantothenic Acid		5.1	5.0	102
Cyanocobalamine		<LOD	1.0	93
Folic Acid		0.25	0.25	106
Vitamin E		15	7.9	*
Retinol Palmitate		<LOD	1.0	*
Brand C	Pyridoxine HCl	2.2	7.6	101
	Ascorbic Acid	<LOD	250	114
	Nicotinic acid	<LOD	7.5	94
	Nicotinamide	10	7.5	100
	D-Pantothenic Acid	6.0	5.0	104
	Cyanocobalamine	<LOD	1.0	94
	Folic Acid	<LOD	0.25	115
	Vitamin E	5.3	7.9	*
	Retinol Palmitate	0.44	1.0	*

\*see text for discussion on recovery values for these vitamins

# Determination of Glucosamine in Dietary Supplements Using HPAE-PAD

## **INTRODUCTION**

Glucosamine (GlcN), an amino sugar, occurs naturally in the human body. It is a major structural component in the biosynthesis of glycosaminoglycans, compounds involved in normal joint function. Use of GlcN as a dietary supplement in the management of osteoarthritis has attracted considerable attention.<sup>1</sup> Results of the 2002 National Health Interview Survey showed that GlcN was one of the five nonvitamin, nonmineral herbal products/dietary supplements most frequently used by adults in the U.S.A.<sup>2</sup> Increased use in Canada was also noted.<sup>3</sup> While the principal use for GlcN dietary supplements is for arthritis management, especially in older adults, its use as a preventive measure to maintain health<sup>4</sup> and in veterinary medicine<sup>5</sup> also has been reported.

The 1994 Dietary Supplement Health and Education Act granted the United States FDA authority to prescribe good manufacturing practices for dietary supplements.<sup>6</sup> The final rule, published in June, 2007, established regulations requiring current good manufacturing practices (cGMP) for dietary supplements.<sup>7</sup> Using the cGMP regulation model for foods, the rule ensures that dietary supplements are produced in a quality manner, do not contain contaminants or impurities, and are accurately labeled.

Previously-reported methods for the determination of glucosamine in dietary supplements have used HPLC with UV or fluorescence detection.<sup>8,9</sup> As

GlcN lacks a chromophore, these methods require either pre- or postcolumn derivatization and are often limited to determining only the glucosamine. However, carbohydrates, glycols, alcohols, amines, and sulfur-containing compounds can be oxidized and therefore detected directly without derivatization using amperometry. Pulsed amperometric detection (PAD), a powerful detection technique with a broad linear range and very low detection limits, is ideally suited for determination of GlcN and related substances. This detection method is specific for those analytes such as GlcN that can be oxidized at a selected potential, leaving all other compounds undetected.

High-performance anion-exchange with pulsed amperometric detection (HPAE-PAD) chromatography is a sensitive, direct-detection technique capable of separating mono- and disaccharides rapidly and efficiently.<sup>10,11</sup> At approximately pH 12, the CarboPac<sup>®</sup> PA20 anion-exchange column will separate and elute neutral monosaccharides, aminosaccharides, and disaccharides while retaining oligosaccharides. The use of HPAE-PAD has been reported for the determination of saccharides in dietary glyconutritional products.<sup>12</sup>

Generating highly reproducible retention times for HPAE chromatographic systems relies on the use of a high purity hydroxide eluent mobile phase prepared with an accurate and precise concentration. An eluent generator (EG) produces such an eluent. The usual variability in hydroxide concentration associated

with manual eluent preparation, and the variability of carbonate contamination due to absorption of atmospheric carbon dioxide, are essentially eliminated by the EG, leading to highly reproducible retention times.

In this application note, a rapid, rugged HPAE-PAD method for determining GlcN in dietary supplement tablets, gelatin capsules, and fortified liquids is described. Key performance parameters are evaluated including accuracy, precision, and limits of detection/quantification, linearity, and ruggedness. The system setup (Figure 1) provides good sample throughput (7.5 min run time) while retaining the selectivity to resolve many other mono- and disaccharides that may be present in the supplement formulation.

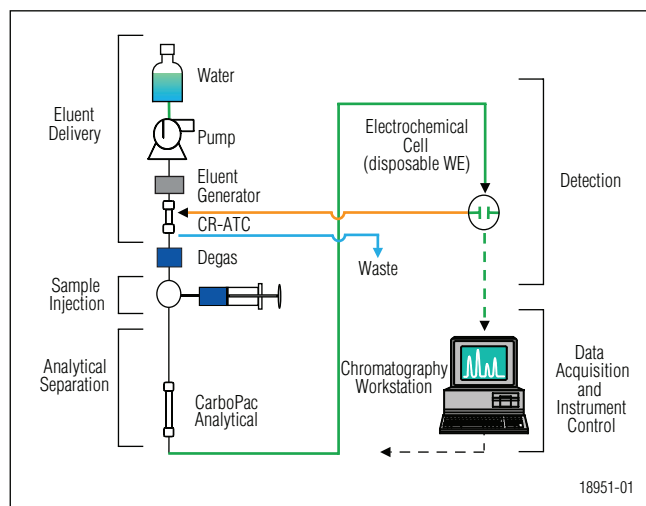

Figure 1. HPAE-PAD system for glucosamine determinations.

## EQUIPMENT

Dionex ICS-3000 Reagent-Free™ Ion Chromatography system with Eluent Generation (RFIC-EG™ system) consisting of:

DP Dual Gradient or SP Single Gradient Pump, with the EG/DP/SP Vacuum Degas Conversion Kit (P/N 063353) and GM-4 Gradient Mixer (P/N 049135)

Eluent Generator with EGC II KOH eluent generator cartridge (EluGen® II Hydroxide; P/N 058900) and Continuously Regenerated Anion Trap Column (CR-ATC; P/N 060477)

DC Detector/Chromatography module equipped with single or dual temperature zones, injection valve(s) and 10 µL injection loop, ED Electrochemical Detector (P/N 079830), ED cell and spacer block

(P/N 061756) with combination pH/Ag/AgCl Reference Electrode (P/N 061879) and Carbohydrate Disposable Au Working Electrodes (P/N 060139, package of 6; 060216, package of 24)

AS Autosampler (with diverter valve for dual systems), and 2 mL vial tray

EO Eluent Organizer, including pressure regulator, and four 2 L plastic bottles for each system

Chromeleon® Chromatography Management Software

Helium; 4.5-grade, 99.995%, <5 ppm oxygen (Praxair)

Filter unit, 0.2 µm nylon (Nalgene® 90 mm Media-Plus, Nalge Nunc International, P/N 164-0020 or equivalent nylon filter)

Vacuum pump (Gast Manufacturing Corp., P/N DOA-P104-AA or equivalent; for degassing eluents)

1.5 mL glass injection vials with caps (Vial Kit, Dionex P/N 055427)

Microcentrifuge tubes with detachable screw caps (polypropylene, 1.5 mL, Sarstedt, P/N 72.692.005; or equivalent)

## REAGENTS AND STANDARDS

Deionized water, 18 MΩ-cm resistance or higher

D(+)-Glucosamine (Sigma-Aldrich; P/N G4875)

Sucrose (Thermo Fisher Scientific; P/N S5500)

Glucose (Sigma-Aldrich; P/N G5250)

D-Sorbitol (Sigma-Aldrich; P/N S1876)

myo-Inositol (Sigma-Aldrich; P/N I5125)

N-Acetyl-D-glucosamine (Sigma-Aldrich; P/N A8625)

D(-)-Fructose (Mallinckrodt Baker; P/N M55605)

Mannitol (Sigma-Aldrich; P/N M9546)

Glycerol (EMD Chemicals; formerly EM Science; P/N GX0190-6)

Propylene glycol (1,2-propanediol; Sigma-Aldrich; P/N P6209)

## SAMPLES

Samples of GlcN-containing tablets, capsules, and beverages were purchased from retail groceries or drugstores. Table 1 lists the expected amount per serving size, source, the salt form of GlcN in each sample, other ingredients listed on the label, and the amount used to prepare the sample.

**Table 1. Description of Glucosamine-Containing Samples**

Sample	mg GlcN (Serving Size)	Size Used for Analysis	GlcN Salt Form	GlcN Source	Other Ingredients
Supplement A	1500 (2 tablets)	1 tablet	HCl	Shellfish	MSM*, cellulose, hypromellose, croscarmellose sodium, stearic acid, silicon dioxide, magnesium stearate, corn starch, povidone, polyethylene glycol
Supplement B	1500 (1 tablet)	1 tablet	HCl	Shellfish	Cellulose, hydroxypropyl cellulose, stearic acid, coating (titanium dioxide, polydextrose, hydroxypropyl methylcellulose, triacetin, polyethylene glycol, magnesium trisilicate), copolyvidone, croscarmellose sodium, silicon dioxide
Supplement C	750 (1 tablet)	1 tablet	HCl	Vegetarian	Sorbitol, dibasic calcium phosphate, stearic acid, modified cellulose gum, colloidal silicon dioxide, wheat/gluten
Supplement D	1000 (1 tablet)	1 tablet	HCl	Vegetarian	Cellulose, modified cellulose gum, stearic acid, magnesium stearate
Supplement E	1000 (1 tablet)	1 tablet	H <sub>2</sub> SO <sub>4</sub>	Not disclosed	Potassium chloride, cellulose, modified cellulose gum, stearic acid, magnesium stearate
Supplement F	1500 (2 capsules)	1 capsule	H <sub>2</sub> SO <sub>4</sub>	Shellfish	Potassium chloride, gelatin, magnesium stearate
Supplement G	1500 (1 can**)	1-237 mL can	HCl	Not disclosed	Sparkling water, orange juice concentrate, citric acid, mango juice concentrate, passionfruit juice, sodium hexametaphosphate, sucralose, potassium sorbate, coloring extracts

\*MSM - Methylsulfonylmethane (dimethylsulfone) present at 1500 mg/serving

\*\*One can contains 237 mL of liquid

### CONDITIONS

Column: CarboPac PA20 Analytical, 3 × 150 mm (P/N 060142)  
 Eluent: 20 mM KOH, isocratic, 7.5 or 15 min run time  
 Eluent Source: EGC II KOH  
 Flow Rate: 0.5 mL/min  
 Injection Volume: 10 µL (full loop)  
 Temperature: 30 °C  
 Detection: Pulsed amperometry, using Carbohydrate Disposable Au Working Electrodes (P/N 060139, package of 6; P/N 060216, package of 24)  
 Background: 40–65 nC  
 Typical System Backpressure: 2580–2730 psi

### Carbohydrate 4-Potential Waveform for the ED

Time (s)	Potential (V)	Gain Region*	Ramp*	Integration
0.00	+0.1	Off	On	Off
0.20	+0.1	On	On	On
0.40	+0.1	Off	On	Off
0.41	-2.0	Off	On	Off
0.42	-2.0	Off	On	Off
0.43	+0.6	Off	On	Off
0.44	-0.1	Off	On	Off
0.50	-0.1	Off	On	Off

\*Settings required in the ICS-3000, but not used in older Dionex systems.

Reference electrode in Ag mode (Ag/AgCl reference).



## Instrument Operational Considerations

Analyze a GlcN check standard at regular intervals to assess both retention time (RT) and peak area precision. When required, a column wash at 100 mM KOH will restore RT for GlcN. The column requires at least 2 h after the column wash to reequilibrate to 20 mM KOH and achieve the highest RT precision. Shorter reequilibrations may yield acceptable precision.

When the system is idle for short (1–2 week) periods, we recommend that the pump and eluent generator be left on at 0.5 mL/min and 20 mM KOH or at a reduced flow rate to allow rapid start-up, and the cell to be turned off to extend disposable electrode life. The use of a lower flow rate, while maintaining the minimum backpressure of at least 200 psi, can extend the interval before water must be added to the eluent reservoir. When the system must be shut down for a period of several weeks, the pump, eluent generator, and electrochemical cell may be turned off. For shutdown periods exceeding several weeks, all plumbing lines should be resealed, and the reference electrode should be removed from the electrochemical cell and stored in the original solution in which it was shipped by Dionex (3.5 M KCl). When the pump has been turned off for longer than 1 day, the column should be washed with 100 mM KOH for 1–2 h, and reequilibrated with 20 mM KOH for 2 h or less (see above) before analyzing samples.

## PREPARATION OF REAGENTS AND STANDARDS

### Eluents

It is essential to use high-quality water of high resistivity (18 M $\Omega$ -cm) containing as little dissolved carbon dioxide as possible. Biological contamination should be absent. Source water must be obtained using a water purification system consisting of filters manufactured without electrochemically active surfactants or other leachable substances (e.g., glycerol). Prior filtration through 0.2  $\mu$ m porosity nylon under vacuum is recommended to remove particulates and reduce dissolved air. Keep the eluent water blanketed under 34–55 kPa (5–8 psi) of helium at all times to reduce carbonate contamination and opportunistic microorganisms.

Although not used to produce the data in this application note, a manually prepared NaOH eluent can be used. Follow the instructions in Dionex Technical Note 71 to prepare 100 or 200 mM NaOH and allow the pump to proportion the 20 mM eluent. Results obtained using manually prepared eluent may not be equivalent to the results reported here.

## Stock Standards

Prepare stock solutions of GlcN and other ingredients in the dietary supplements by accurately weighing standards into tared plastic vials. Add filtered and degassed DI water and weigh the resulting solution. Prepare stock standard solutions at concentrations of approximately 1.0 mM. Store stock standards at -15 °C. Dilute stock standards with filtered, degassed water to yield the desired working mixture concentrations. For this application note, all dilutions were made gravimetrically to ensure high accuracy and concentrations reported as GlcN free base.

## SAMPLE PREPARATION

Place tablet or capsule sample in a 1.0 L volumetric flask and add approximately 500 mL of filtered DI water. Place the flask into an ultrasonic bath until the sample is fully dispersed (20–30 min) and then bring to volume with filtered DI water. Pour liquid dietary supplement sample into a 1.0 L volumetric flask, carefully degas under vacuum, and bring to volume with filtered, degassed DI water. Make further dilutions by placing 1 mL aliquots in 1.5 mL plastic microcentrifuge vials with detachable screw caps and centrifuge at 16,000  $\times$  g in a microcentrifuge for 20 min. Dilute the supernatant gravimetrically to produce sample stock solutions expected to have 1.0 mM (180  $\mu$ g/mL) GlcN free base concentrations based on product label information. Further dilute aliquots from the 1.0 mM solutions gravimetrically to produce solutions for injection into the HPAE-PAD system.

Quantitative results for GlcN concentration and for concentrations of other putatively identified ingredients were converted to the masses of these compounds in the original sample (one tablet or capsule or one 237 mL can of liquid). Two factors, the dilution factor (DF) and the molar conversion factor (CF) were needed for this calculation. The DF represents the factor required to dilute product solutions from their concentration in the 1.0 L volumetric flask to their injected target concentrations. Dilutions used for this application note are listed in Table 3. The CF represents the factor that converts concentrations found for GlcN and other putatively identified ingredients to mass of the analyte in the original sample. For supplements containing GlcN as the sulfate salt, CF was 228 (half the FW of 2GlcN·H<sub>2</sub>SO<sub>4</sub>). Supplements E and F contained GlcN as its H<sub>2</sub>SO<sub>4</sub> salt. For Supplements A, B, C, D and G, which contained GlcN as its chloride salt, the CF was 216 (the

FW of GlcN·HCl). For other substances, CF was the compound's MW. To convert the measured GlcN free base concentration (expressed as  $\mu\text{M}$ ,  $\mu\text{moles/L}$ ) to mg of GlcN as its appropriate salt form per unit dissolved in the original 1.0 L of water, the following equation was used:

$$\frac{\text{mg GlcN (salt form)}}{\text{unit}} = \frac{\mu\text{mol GlcN}}{\text{L}} \times \text{DF} \times \text{CF} \times 1.0 \frac{\text{L}}{\text{unit}} \times 0.001 \frac{\text{mg}}{\mu\text{g}}$$

A unit of supplement is a tablet, capsule, can, packet, or any other amount of product dissolved or diluted in 1.0 L of water to prepare the sample concentrate. For example, if the GlcN concentration in the diluted sample of Supplement A is determined to be  $10.0 \mu\text{M}$ , the amount of GlcN·HCl in the tablet dissolved in 1.0 L water is:

$$\frac{\text{mg GlcN}\cdot\text{HCl}}{\text{unit}} = \frac{10 \mu\text{mol}}{\text{L}} \times 350 \times 216 \frac{\mu\text{g GlcN}\cdot\text{HCl}}{(\mu\text{mol GlcN free base})} \times 1.0 \frac{\text{L}}{\text{unit}} \times 0.001 \frac{\text{mg}}{\mu\text{g}} = 756 \frac{\text{mg}}{\text{unit}}$$

Method accuracy was assessed from recovery of known amounts of GlcN spiked into either DI water or Supplement B previously diluted to an expected GlcN concentration of  $9.9 \mu\text{M}$  ( $1.8 \mu\text{g/mL}$ ). A  $1.00 \text{ mM}$  ( $179 \mu\text{g/mL}$ ) GlcN standard was used to accurately spike the Supplement B sample at 50% and 100% of the expected GlcN concentration in the supplement.

## RESULTS AND DISCUSSION

### Separation

Figure 2A shows chromatograms for the seven GlcN dietary supplements diluted to the target  $10 \mu\text{M}$  ( $1.8 \mu\text{g/mL}$ ) GlcN concentration. The CarboPac PA20, combined with PAD, yielded simple chromatograms for most of the supplements tested. In Supplement A, the high concentration of methylsulfonylmethane (MSM), another active ingredient in this product, was not detected and did not interfere with the GlcN determination. Sorbitol in Supplement C, an inactive ingredient (preservative), was detected but did not interfere. In liquid Supplement G, glucose, fructose, sucrose, and *myo*-inositol were also observed and sufficiently separated from GlcN. The added non-nutritive sweetener, sucralose, was retained on the CarboPac PA20 column and was not eluted using this method. Sucralose can be determined using similar methods.<sup>13,14</sup> Although we expected the possibility that *N*-acetyl-glucosamine might be present in some of the dietary supplements from shellfish sources, it was not detected.

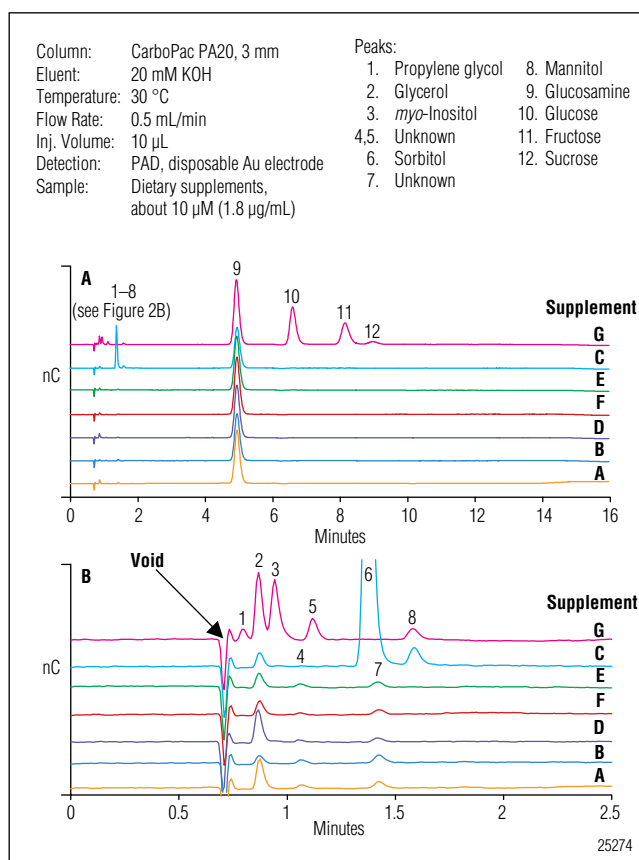

Figure 2. HPAE-PAD analysis of GlcN-containing dietary supplements. Seven dietary supplement samples diluted to approximately  $10 \mu\text{M}$  ( $1.8 \mu\text{g/mL}$ ) GlcN,  $10\text{-}\mu\text{L}$  injection. A) Full chromatogram. B) Expanded early RT region of the chromatogram.

Trace amounts of other, unidentified ingredients can be seen in Figure 2B. Peaks 4 and 7 are detected in all tablet and capsule samples analyzed, except in Supplement C, where peak 7 may be masked by sorbitol, peak 6. Neither peak was detected in the beverage (Supplement G). Table 1 lists the other ingredients present in the seven dietary supplements evaluated in this note. The combined use of HPAE and the specificity of PAD yields an uncomplicated chromatogram for determination of GlcN.

Eluent concentrations of 10–15 mM KOH caused the GlcN peak to coelute with a baseline dip, typically having a retention time of 6 min. Baseline dips associated with injections of water or samples are caused by the elution of non-electrochemically active trace organic impurities present in the sample. When these compounds elute, they exclude electrochemically active ions present in the eluent and appear as negative peaks. The “oxygen dip” (~16 min retention time for the column used in this study) is due to oxygen present in the samples and appears as a function of the gas permeation volume of the column. The

retention times of the “oxygen dip” and other baseline dips are constant for each column, but vary slightly from column to column; and many depend on the flow rate, not the eluent strength. Increasing the eluent strength to 20 mM KOH decreased the GlcN retention time to 5.0 min and thus removed any effect of the dip at 6 min on GlcN peak integration.

Eluting the baseline dips just prior to the end of the run, or timing their elution to occur at the end of the following injection, prevents the baseline dips from interfering with the peaks of interest. Using the overlapping sample preparation configuration (flushing the injection port, needle, and autosampler tubing for the next sample during the separation of the current sample), a run time of 7.5 min (total time between injections of 8.6 min) will produce a relatively flat baseline for integration of peaks having retention times between 1–6 min. For samples with compounds eluting later than GlcN, the run time can be set to 16 min without significant baseline interfere from the oxygen dip.

## Detection

### Linearity

Figure 3A presents the relationship of GlcN peak area (nC\*min) to concentration of the GlcN injected (10 µL) over a broad range of concentrations, 0 to 1000 µM (0–179 µg/mL). In this study the lower limit of detection was estimated to be 0.09 µM (0.02 µg/mL). The full linear range in this study covered more than 3 orders of magnitude, 0.30–340 µM, 0.06–61 µg/mL, for a 10 µL injection. For routine GlcN determination we recommend a dietary supplement dilution scheme that targets a 10 µM (1.8 µg/mL) GlcN concentration. Figure 3B presents a plot covering a narrower concentration range of 1.8–36 µM (0.32–6.4 µg/mL) where the target concentration is near the middle of this range. The  $r^2$  value in this range is >0.9998.

### Precision

GlcN retention time and peak area RSDs were determined for replicate injections of Supplement B supernatant (GlcN concentration targeted to 10 µM [1.8 µg/mL] for 10 µL injection) over 5 days (718 injections). Supplement B was chosen for this study because the label lists several cellulosic compounds as part of this dietary supplement tablet and was considered among the more challenging matrices of the products investigated in this note. Run times were 7.5 min (injections made every 8.6 min). Table 2 shows these

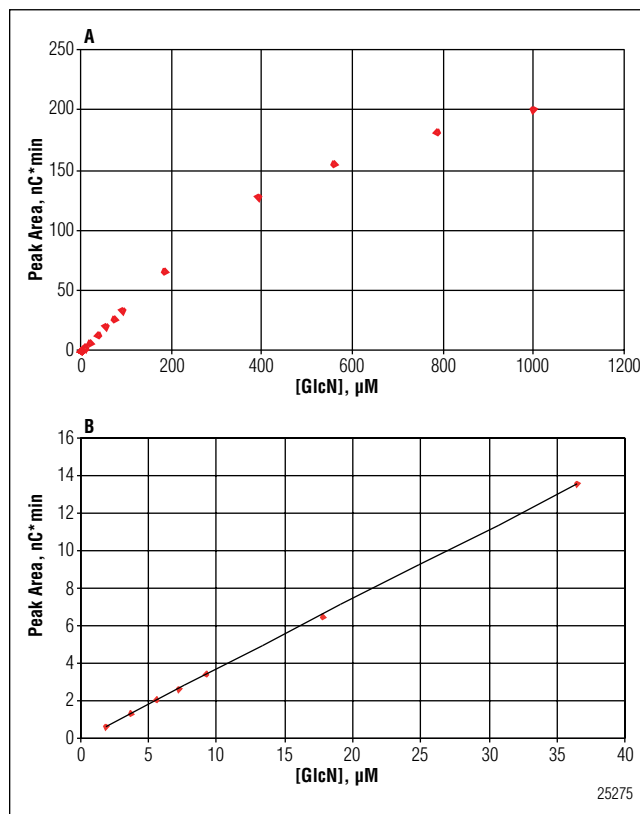

Figure 3. The relationship of peak area (mean) to glucosamine concentration injected for estimation of linear range ( $n = 8$ ). A) Wide range curve. B) Narrower range used for GlcN quantification.

**Table 2. Precision of Glucosamine Retention Time and Peak Area for Supplement B Injected Consecutively Over 5 Days**

	Day					All 5 Days	% Change over 5 Days
	1	2	3	4	5		
<b>Retention Time (min)</b>							
<b>Mean</b>	4.972	4.937	4.908	4.899	4.896	4.922	-1.53
<b>SD</b>	0.011	0.011	0.007	0.007	0.009	0.03	
<b>N</b>	144	146	145	141	142	718	
<b>RSD</b>	0.22	0.22	0.14	0.14	0.18	0.61	
<b>Peak Area (nC*min)</b>							
<b>Mean</b>	4.096	4.073	4.049	4.029	4.034	4.057	-1.51
<b>SD</b>	0.034	0.027	0.034	0.045	0.035	0.043	
<b>N</b>	144	146	145	141	142	718	
<b>RSD</b>	0.83	0.66	0.84	1.12	0.87	1.06	

results on a daily basis and for the 5-day period. The column was washed for 1 h at 100 mM KOH prior to this study, but no wash was performed during this 5-day period.

### Retention Time

Buildup on the stationary phase of non-eluting sample ingredients and carbonate contaminants from the eluent can result in decreasing capacity and eventually can decrease the retention time for GlcN. An EG essentially eliminates carbonate contamination; therefore, the only remaining concern is loss of column capacity due to sample ingredients. The data in Table 2 shows high retention time precision and little loss of retention time over the 5 days, despite injecting a challenging sample with no column washes during the 5-day period.

### Peak Area

Peak area precision is a measure of the ECD response stability and the variance in response for replicate injections. Table 2 shows there was good GlcN peak area reproducibility during the 5-day study.

### Accuracy

GlcN recovery from DI water and a diluted aqueous extract of a dietary supplement was evaluated in this application note. Percent recovery (mean  $\pm$  SD) from DI water at 5.1  $\mu$ M (0.91  $\mu$ g/mL) and 10.1  $\mu$ M (1.81  $\mu$ g/mL) was 101  $\pm$  1.3 and 102  $\pm$  0.3 %, respectively. Recoveries from Supplement B supernatant spiked at 5.1  $\mu$ M (0.91  $\mu$ g/mL) and 9.9  $\mu$ M (1.77  $\mu$ g/mL) were 93.4  $\pm$  3.0 and 99.0  $\pm$  2.5 %, respectively, indicating that the method was accurate.

### Application

Figure 2 presents chromatograms for the seven GlcN-containing dietary supplements studied. No other peaks were observed when run times were extended to 30 min. Table 3 shows the measured amounts of GlcN in the seven dietary supplements analyzed for this note, derived from a 7-point calibration over the 1.8–36  $\mu$ M (0.32–6.4  $\mu$ g/mL) range. The determined amounts of GlcN for all seven supplement samples were above the stated label amounts, ranging from 110%–152% of the GlcN label value.

Some dietary supplements showed significant amounts of PAD-responsive related substances using this method (Figure 2). The peaks for these related substances were putatively identified by matching their retention times with those of carbohydrate and glycol standards. Single-level calibrations were used to estimate the amount

**Table 3. Determination of Glucosamine in Dietary Supplement Samples**

Sample	Dilution Factor (DF)	Measured Amount, mg/unit <sup>a</sup>	Expected Amount, mg/unit <sup>b</sup>	% GlcN Found $\pm$ SD
Supplement A	350	959 $\pm$ 9.5	750	128 $\pm$ 1.3
Supplement B	659	1650 $\pm$ 2.5	1500	110 $\pm$ 1.7
Supplement C	455	966 $\pm$ 3.5	750	129 $\pm$ 0.5
Supplement D	413	1130 $\pm$ 4.1	1000	113 $\pm$ 0.4
Supplement E	467	1370 $\pm$ 2.5	1000	137 $\pm$ 0.3
Supplement F	315	991 $\pm$ 5.2	750	132 $\pm$ 0.7
Supplement G	680	2270 $\pm$ 11	1500	152 $\pm$ 0.7

<sup>a</sup>Calculated amount = [GlcN] found  $\times$  DF  $\times$  CF, converted to mg

<sup>b</sup>Expected amount derived from Supplement Facts on label

**Table 4. Determination of Other Substances Detected in Dietary Supplements**

Sample	Analyte <sup>a</sup>	Calculated amount/unit (mg/unit) <sup>b,c</sup> $\pm$ SD	% Relative to Measured [GlcN] $\pm$ SD
Supplement A	Glycerol	28.1 $\pm$ 0.6	2.9 $\pm$ 0.1
Supplement B	Glycerol	17.6 $\pm$ 1.1	1.1 $\pm$ 0.1
Supplement C	Glycerol	16.8 $\pm$ 0.4	1.74 $\pm$ 0.04
	<i>myo</i> -Inositol	0.7 $\pm$ 0.4	0.07 $\pm$ 0.04
	Sorbitol	307 $\pm$ 1.5	31.8 $\pm$ 0.2
Supplement C	Mannitol	43.9 $\pm$ 1.4	4.5 $\pm$ 0.1
	Glycerol	37.3 $\pm$ 1.8	3.3 $\pm$ 0.2
Supplement D	Glycerol	37.3 $\pm$ 1.8	3.3 $\pm$ 0.2
Supplement E	Glycerol	18.5 $\pm$ 0.5	1.35 $\pm$ 0.04
Supplement F	Glycerol	12.7 $\pm$ 0.3	1.28 $\pm$ 0.03
Supplement G	Propylene glycol	5.44 $\pm$ 0.08	0.24 $\pm$ 0.01
	Glycerol	125 $\pm$ 2.7	5.5 $\pm$ 0.1
	<i>myo</i> -Inositol	61.7 $\pm$ 0.8	2.72 $\pm$ 0.04
	Mannitol	43 $\pm$ 2.2	1.9 $\pm$ 0.1
	Glucose	1380 $\pm$ 11	60.8 $\pm$ 0.6
	Fructose	1939 $\pm$ 4.5	85.4 $\pm$ 0.5
	Sucrose	300 $\pm$ 11	13.2 $\pm$ 0.5

n = 5 injections per sample

<sup>a</sup>Putative identification based on retention time matches with standards

<sup>b</sup>A unit is 1 tablet, 1 capsule, or 1 237-mL can of liquid

<sup>c</sup>Calculated amount = [substance] found  $\times$  DF  $\times$  MW, converted to mg

of these ingredients in the supplements. Table 4 shows the amounts of these related substances, expressed as mg/unit. Unknown ingredient peaks 4 and 7 (Figure 2B), present in all products except Supplement G, showed peak areas relative to GlcN ranging from 0.08–0.27% and 0.29–0.63%, respectively. This method can also be used to determine other carbohydrates or glycols present in dietary supplements. Higher concentration GlcN solutions can be injected for determination of trace mono- and disaccharide concentrations, if desired, for evaluation of GlcN quality.

### **CONCLUSION**

HPAE-PAD with eluent generation can be used to determine glucosamine in dietary supplements without the pre- or postcolumn derivatization required when using UV or fluorescence detection. Sample preparation consists of simply dissolving samples in DI water and diluting the resulting solution to a target concentration within the linear range. The high capacity of the CarboPac PA20 and the use of eluent generation enable the isocratic analysis of over 100 samples per day for 5 days with the analyst required to add only water and samples to the system. This method works for a variety of sample matrices, as demonstrated by the practical application of this method to the accurate determination of GlcN in seven dietary supplements.

### **REFERENCES**

1. Theodosakis, J.; Adderly, B.; Fox, B. *The Arthritis Cure*. St. Martin's Press: New York, 1997.
2. Kennedy, J. Herb and Supplement Use in the US Adult Population. *Clin. Ther.* **2005**, *27*, 1845–1858.
3. Hopman, W.M.; Towheed, T.E.; Gao, Y.; Berger, C.; Joseph, L.; Vik, S.A.; Hanley, D.A.; Carran, J.; Anastassiades, T. Prevalence of and Factors Associated with Glucosamine Use in Canada. *Osteoarthritis and Cartilage* **2006**, *14*, 1288–1293.
4. Gorsline, R.T.; Kaeding, C.C. The Use of NSAIDs and Nutritional Supplements in Athletes with Osteoarthritis: Prevalence, Benefits, and Consequences. *Clin. Sports Med.* **2005**, *24*, 71–82.
5. Ramey, D.W.; Eddington, N.; Thonar, E.; Lee, M. An Analysis of Glucosamine and Chondroitin Sulfate Content in Oral Joint Supplement Products. *J. Equine Vet. Sci.* **2002**, *22*, 125–127.
6. Dietary Supplement Health and Education Act of 1994, Public Law 103-417. U. S. Food and Drug Administration Center for Food Safety and Applied Nutrition. 1995. <http://www.fda.gov/opacom/laws/dshea.html>.
7. U.S. Department of Health and Human Services, Food and Drug Administration, 21 CFR Part 111 Current Good Manufacturing Practice in Manufacturing, Packaging, Labeling, or Holding Operations for Dietary Supplements; Final Rule. *Fed. Regist.* **2007**, *72*, 34751–34958. <http://www.fda.gov/OHRMS/DOCKETS/98fr/07-3039.pdf>.
8. Shen, X.; Yang, M.; Tomellini, S. A. Liquid Chromatographic Analysis of Glucosamine in Commercial Dietary Supplements Using Indirect Fluorescence Detection. *J. Chromatogr. Sci.* **2007**, *45*, 70–75.
9. Ji, D.; Zhang, L.; Chen, J.; Peng, E. Precolumn Derivatization Liquid Chromatography Method for Analysis of Dietary Supplements for Glucosamine: Single Laboratory Validation Study. *J. AOAC Int.* **2005**, *88*, 413–417.

- 
10. Dionex Corporation. *Glycoprotein Monosaccharide Analysis Using High-Performance Anion-Exchange Chromatography with Pulsed Amperometric Detection (HPAE-PAD) and Eluent Generation*. Technical Note 40; LPN 1632. Sunnyvale, CA, 2004.
  11. Dionex Corporation. *Analysis of Carbohydrates by High-Performance Anion-Exchange Chromatography with Pulsed Amperometric Detection (HPAE-PAD)*. Technical Note 20; LPN 032857-04. Sunnyvale, CA, 2000.
  12. Eberendu, A.R.; Booth, C.; Luta, G.; Edwards, J.A.; McAnalley, B.H. Quantitative Determination of Saccharides in Dietary Glyconutritional Products by Anion-Exchange Liquid Chromatography with Integrated Pulsed Amperometric Detection. *J. AOAC Int.* **2005**, *88*, 998–1007.
  13. Dionex Corporation. *Determination of Sucralose Using HPAE-PAD*. Application Note 159; LPN 1574. Sunnyvale, CA, 2004.
  14. Dionex Corporation. *Determination of Sucralose in Reduced-Carbohydrate Colas using High-Performance Anion-Exchange Chromatography with Pulsed Amperometric Detection*. Application Update 151; LPN 1766. Sunnyvale, CA, 2006.

## **SUPPLIERS**

- EMD Chemicals Inc., 480 South Democrat Road, Gibbstown, NJ 08027, U.S.A. Tel: 1-800-222-0342 <http://www.emdchemicals.com>.
- Gast Manufacturing Corp., 2550 Meadowbrook Road, Benton Harbor, MI 49022, U.S.A. Tel: 1- 269-926-6171, <http://www.gastmfg.com>.
- Mallinckrodt Baker, 222 Red School Lane, Phillipsburg NJ 08865, U.S.A. 1-800-582-2537 <http://www.mallbaker.com>.
- Nalge Nunc International, 75 Panorama Creek Drive, Rochester, NY 14625, U.S.A. Tel: 1-800-625-4327, <http://www.nalgenunc.com>.
- Praxair, 39 Old Ridgebury Road, Danbury, CT 06810-5113, U.S.A. Tel: 877-772-9247, <http://www.praxair.com>.
- Sarstedt AG & Co., Rommelsdorfer Straße, Postfach 1220, 51582 Nümbrecht, Germany  
Tel.: +49-2293-305-0, <http://www.sarstedt.com>.
- Sigma-Aldrich Chemical Company, P.O. Box 14508, St. Louis, MO 63178, U.S.A., Tel: 1-800-325-3010, [www.sigma.sial.com](http://www.sigma.sial.com).
- Thermo Fisher Scientific, 4500 Turnberry Drive, Hanover Park, IL 60133, U.S.A.  
Tel: 1-800-766-7000 [www.fishersci.com](http://www.fishersci.com).

# Determination of Vitamin B<sub>12</sub> in Beverages Using On-Line SPE Followed by HPLC with UV Detection

## INTRODUCTION

Cyanocobalamin (Vitamin B<sub>12</sub>) belongs to the B vitamin group and prevents pernicious anemia, which is caused by Vitamin B<sub>12</sub> deficiency. Because plant products contain very little Vitamin B<sub>12</sub>, vegetarians and people who do not eat red meat need to supplement their diet by taking multivitamin tablets and beverages supplemented with Vitamin B<sub>12</sub>. As the excessive consumption of Vitamin B<sub>12</sub> may cause asthma and folic acid deficiency, therefore, typically only a low level of Vitamin B<sub>12</sub> (e.g., ng/g) is added to products, thus making direct analysis difficult. As a result, Vitamin B<sub>12</sub> analysis usually involves complicated sample preparation, which presents challenges for product quality control.

Reversed-phase high-performance liquid chromatography (HPLC) with fluorescence,<sup>1</sup> mass spectrometry,<sup>2,3</sup> or ultraviolet (UV)<sup>4,5</sup> detection are good techniques for Vitamin B<sub>12</sub> determination. Extracting Vitamin B<sub>12</sub> from a larger amount of sample is simple and effective for some relatively large and solid samples, such as multivitamin tablets; however, this strategy is not always suitable for liquid samples (e.g., beverages). In order to have enough Vitamin B<sub>12</sub> to detect, the size of the direct large-volume injection required also introduces interfering compounds. Therefore, adsorption onto charcoal, anion-exchange chromatography, or solid-phase extraction (SPE) on reversed-phase cartridges are the techniques usually used for concentrating the analyte from liquid samples while eliminating most of the interfering compounds.<sup>6</sup>

The Dionex UltiMate® 3000 ×2 Dual HPLC system has been used to successfully execute on-line SPE methods that, coupled with HPLC, determine phenols in drinking and bottled water<sup>7</sup> and polycyclic aromatic hydrocarbons (PAHs) in edible oils<sup>8</sup> and drinking water.<sup>9</sup> The Acclaim® Polar Advantage II (PA2) is a polar-embedded column designed for enhanced hydrolytic stability within a wide range of pH values (pH 1.5 to 10). It is compatible with 100% aqueous mobile phases, overcoming the limitations of conventional C8 and C18 reversed-phase columns. Thus, the PA2 column is a good SPE choice for concentrating polar and non-polar components in large-volume water samples (e.g., tap water and beverages) without adding organic solvents.

The work shown here reports a simple, fast, and effective on-line SPE method, followed by HPLC with UV detection, performed on an UltiMate 3000 HPLC system including a dual-gradient pump, autosampler, and column oven equipped with one 2p to 6p valve for determination of trace amounts of Vitamin B<sub>12</sub> added to beverages. An additional 2p to 6p valve can be added to this system for convenient method development. A small change in the flow scheme of the traditional on-line SPE mode reverses the flush direction on the SPE column and creates an on-line SPE system with a dual function (i.e., trapping the analyte and partially separating it from interferences prior to the analytical column) that eliminates interferences much more efficiently. Using this on-line SPE system, Vitamin B<sub>12</sub> in the beverage is

trapped on an Acclaim PA2 SPE column and subsequently separated on an Acclaim PA2 analytical column. The entire analysis process is completed within 16 min and offers the advantages of full automation, absence of operator influence, and strict process control, compared to the traditional off-line SPE method.<sup>10</sup> The off-line SPE method requires ~ 3 h just for sample preparation and is inefficient in its elimination of interferences. Although use of a vacuum SPE device to handle many samples in parallel may decrease average per-sample analysis time, the procedure is still complex and, therefore, not suitable for fast real-time monitoring during manufacture.

### **EQUIPMENT**

Dionex UltiMate 3000 HPLC system including:

DGP-3600A pump with SRD-3600 solvent rack with degasser

WPS-3000TSL semiprep autosampler (with 2.5 mL sample loop)

TCC-3200 Thermostatted Column Compartment equipped with two 2p–6p valves

VWD-3400RS UV-vis Detector

Chromleon<sup>®</sup> Chromatography Data System (CDS) software Version 6.80 SR7

Orion 420A+ pH meter, Thermo Scientific

### **Conversion of WPS-3000TSL Autosampler for Large-Volume Injection for On-Line SPE**

The WPS-3000TSL autosampler has up to 45 positions for 10 mL vials that can accommodate the 2500  $\mu$ L (and even 7500  $\mu$ L) injection volume. By default, it features 15 positions in the triangular 5-position holders. In addition, the autosampler may be equipped with up to three 10-position, 10 mL trays (P/N 6820.4086) to increase the sample capacity for such applications. Because a sample volume of at least 2500  $\mu$ L needs to be injected, the semipreparative version of the WPS-3000 autosampler is required (P/N 5822.0028 with temperature control, or 5822.0018 without temperature control). It is possible to convert an analytical WPS-3000(T)SL to the semipreparative variant by installing the Semipreparative Conversion Kit (P/N 6822.2450).<sup>9</sup>

### **REAGENTS**

Deionized water, Milli-Q<sup>®</sup> Gradient A10, Millipore Corporation

Acetonitrile (CH<sub>3</sub>CN), HPLC grade, Fisher

Potassium dihydrogen phosphate (KH<sub>2</sub>PO<sub>4</sub>), phosphoric acid (H<sub>3</sub>PO<sub>4</sub>), analytical grade, SCRC, China

### **STANDARD**

Cyanocobalamine (Vitamin B<sub>12</sub>) standard ( $\geq 97\%$ ) was purchased from National Institute for the Control of Pharmaceutical and Biological Products (NICPBP), China. Prepare a stock standard solution with concentration of 1.0 mg/mL by accurately weighing 10 to 20 mg of Vitamin B<sub>12</sub> powder and adding DI water to 10 to 20 g.

### **SAMPLE PREPARATION**

Four types of beverages with different flavors were purchased from two Shanghai, China supermarkets. Prepare spiked samples by adding the proper volume of the stock standard solution to 100 mL of beverage. Filter samples through a 0.45  $\mu$ m membrane (Millex<sup>®</sup>-HN) before analysis.

### **CONDITIONS**

On-Line SPE

Column: Acclaim PA2, 3  $\mu$ m, 3.0  $\times$  33 mm (P/N 066276) or 4.6  $\times$  50 mm (P/N 063819)

Analytical

Column: Acclaim PA2, 3  $\mu$ m, 3.0  $\times$  150 mm (P/N 063705)

Column

Temperature: 25  $^{\circ}$ C

Mobile Phase: For both SPE and separation pumps  
A: 25 mM Phosphate buffer (dissolve ~ 3.4 g KH<sub>2</sub>PO<sub>4</sub> in 1 L water and adjust pH to 3.2 with H<sub>3</sub>PO<sub>4</sub>)  
B: CH<sub>3</sub>CN

In gradient (Table 1 for using the 3.3  $\times$  30 mm of SPE column, Table 2 for using the 4.6  $\times$  50 mm SPE column)

Flow Rate: Tables 1 and 2

Injection Volume: 2500  $\mu$ L on the SPE column

UV Detection: Absorbance at 361 nm



**Table 1. Gradients and Valve Switching for the Developed On-Line SPE Mode (Using the Acclaim PA2 Column, 3  $\mu$ m, 3.0  $\times$  33 mm) and Separation**

Time (min)	Right Pump (for Separation)			Left Pump (for On-Line SPE)			Valve Switching	
	Flow Rate (mL/min)	Solvent A Buffer (% Vol.)	Solvent B CH <sub>3</sub> CN (% Vol.)	Flow Rate (mL/min)	Solvent A Buffer (% Vol.)	Solvent B CH <sub>3</sub> CN (% Vol.)	Left	Right
0.00	0.6	90	10	0.6	97	3.0	6-1	1-2
6.00		—	—		97	3.0		—
9.00		90	10		77	23		—
9.17		—	—		—	—		6-1
9.45		—	—		20	80		1-2
11.00		—	—		20	80		—
11.10		—	—		97	3.0		—
13.00		58	42		—	—		—
13.50		20	80		—	—		—
14.50		20	80		—	—		—
14.60		90	10		—	—		—
16.00		90	10		97	3.0		—

**Table 2. Gradients and Valve Switching for the Developed On-Line SPE Mode (Using the Acclaim PA2 Column, 3  $\mu$ m, 4.6  $\times$  50 mm) and Separation**

Time (min)	Right Pump (for Separation)			Left Pump (for On-Line SPE)			Valve Switching	
	Flow Rate (mL/min)	Solvent A Buffer (% Vol.)	Solvent B CH <sub>3</sub> CN (% Vol.)	Flow Rate (mL/min)	Solvent A Buffer (% Vol.)	Solvent B CH <sub>3</sub> CN (% Vol.)	Left	Right
0.0	0.5	90	10	1.0	97	3.0	6-1	1-2
7.0		—	—		97	3.0	—	—
11.4		90	10		—	—	—	—
11.65		—	—	1.5	—	—	—	6-1
12.0		—	—		70	30	—	—
12.15		—	—		—	—	—	1-2
12.5		—	—		0	100	—	—
14.0		—	—		0	100	—	—
14.1		—	—		70	30	—	—
16.0		55	45		—	—	—	—
16.5		0	100		—	—	—	—
19.0		0	100		70	30	—	—
19.1		90	10		—	—	—	—
19.5	—	—	1.0	70	30	—	—	
20.0	90	10		97	3.0	—	—	

## RESULTS AND DISCUSSION

### Evaluation of Direct Large-Volume Injection

After a large volume of filtered aqueous sample solution (2500  $\mu\text{L}$ ) was drawn into the loop, the loop was switched into the flow path. The sample solution in the loop was delivered as a continuous sample (no mixing with the mobile phase) to the analytical column, and the analytes were bound to the front-end of the analytical column, due to the very weak elution ability of the aqueous sample solution. The analytes were then eluted as the mobile phase containing organic solvent passed through the column. The analytical column has both SPE and separation functions. Although a low concentration (1 ng/mL, Figure 1A) of Vitamin B<sub>12</sub> standard may be successfully analyzed using this injection mode, the determination had significant interference when applied to real sample analysis (Figure 1C), demonstrating that it cannot be applied at this concentration range.

### Evaluation of Traditional On-Line SPE

The commonly used on-line SPE flow scheme (shown in Figure 2) was directly coupled to the analytical HPLC column using one six-port (2p to 6p) column valve. The filtered sample was injected directly onto the system and delivered to the SPE column for enrichment (1-2 position) using the left pump; the analytical column was simultaneously equilibrated with the right pump. After the analytes were bound to the SPE column and impurities washed out, the SPE column was switched into the analytical flow path to elute the bound analytes (6-1 position). Then the analytes were separated on the analytical column and detected by the UV detector.

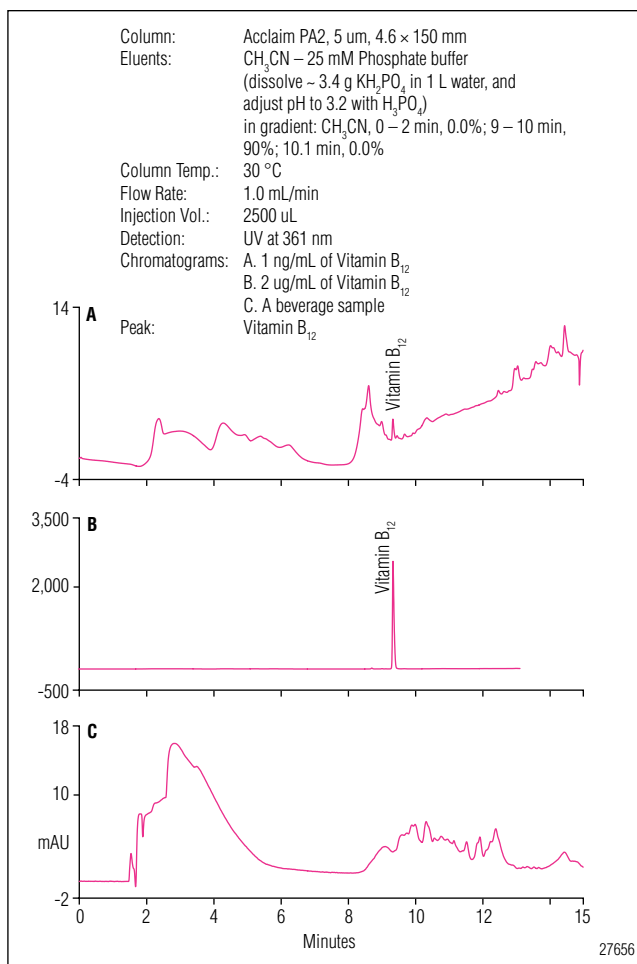

Figure 1. Chromatograms using the direct, large injection volume mode.

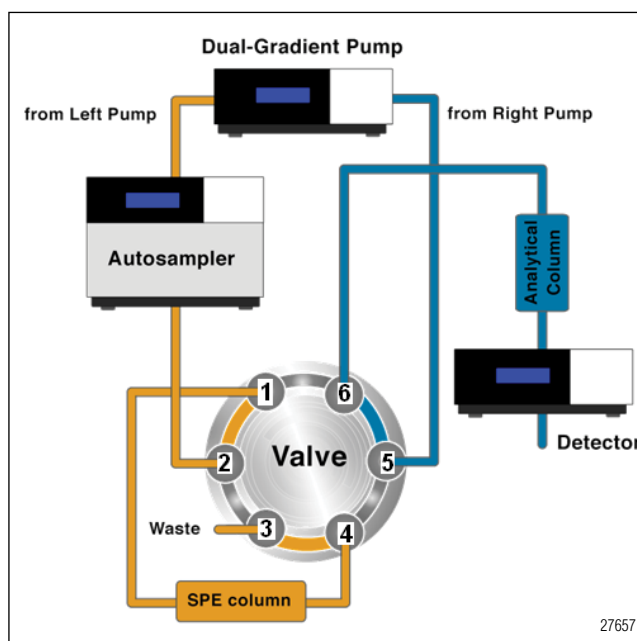

Figure 2. Flow schematic for traditional on-line SPE mode for sample preparation and analysis.

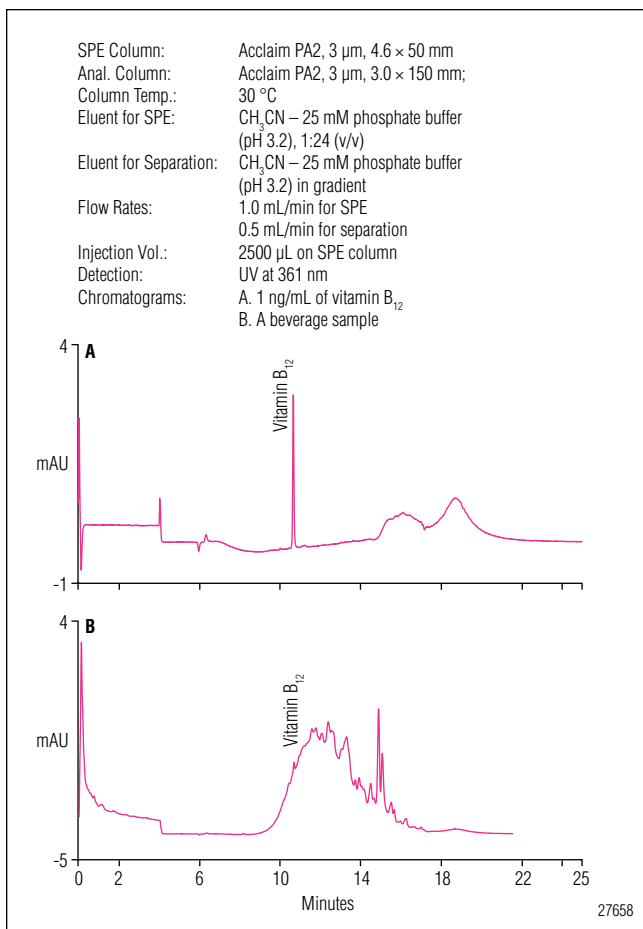

Figure 3. Chromatograms using the traditional on-line SPE mode.

As shown in Figure 3, compared to using the direct large-volume injection mode, there was a better analysis result for the same sample; however, the elimination of interferences was not efficient, and the determination of Vitamin B<sub>12</sub> still was compromised. Table 3 lists the gradient and valve-switching times.

#### Development of On-Line SPE Mode with Dual Function

A small change in the flow scheme of the traditional on-line SPE mode reverses the flush direction on the SPE column, as shown in Figure 4, and creates an on-line SPE system on which the SPE step can have a dual function to more efficiently eliminate interferences. The SPE process in the developed mode is different from that described in the traditional one. The bound analyte on the SPE column is more selectively eluted from the SPE column using a mobile phase gradient similar to the first dimension of a two-dimensional chromatography system. As the SPE process runs (1-2 position), the analytical column equilibrates. Just before the front

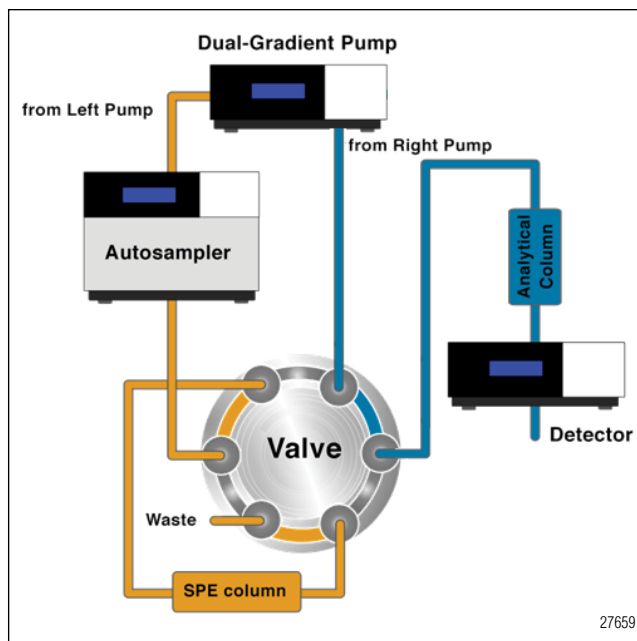

Figure 4. Flow schematic for the developed on-line SPE mode equipped with one 2p to 6p valve.

Time (min)	Right Pump (for Separation)			Left Pump (for On-Line SPE)			Valve Switching
	Flow Rate (mL/min)	Solvent A Buffer (% Vol.)	Solvent B CH <sub>3</sub> CN (% Vol.)	Flow Rate (mL/min)	Solvent A Buffer (% Vol.)	Solvent B CH <sub>3</sub> CN (% Vol.)	
0.0	0.5	96	4	1.0	96	4.0	—
4.0		96	4				1-2
12.0		40	60				—
12.5		10	90				—
15.1		96	4				—
16.0		—	—				6-1
25.0		96	4				—

portion of the analyte peak elutes from the SPE column, the SPE column switches into the analytical flow path (6-1 position). As soon as the analyte is completely eluted from the SPE column, the SPE column switches out of the analytical flow path and back to the SPE flow path (1-2 position). Therefore, only those interferences co-eluting with analytes enter the analytical column, and more interferences are removed. The volume of analyte cut from the SPE column is separated on the analytical column and detected by the UV detector.

This newly developed on-line SPE mode with a dual function (i.e., analyte capture and partial separation) runs automatically, controlled by Chromeleon software.

Setting the valve-switching time is the key to success of this on-line SPE mode. The following equation may be used to estimate the valve-switching time:

$$t_{\text{valve-switching } 2} = t_{\text{valve-switching } 1} + (v_1/v_2) \times w_h$$

The notation  $t_{\text{valve-switching } 1}$  represents the first valve-switching time when the front shoulder of the analyte peak is just eluting from the SPE column at the flow rate for SPE;  $t_{\text{valve-switching } 2}$  represents the second valve-switching time when the SPE column is switched out of the analytical flow path;  $v_1$  and  $v_2$  represent the flow rates for SPE and separation, respectively; and  $w_h$  represents baseline peak width (min) of Vitamin B<sub>12</sub> on the SPE column.

Therefore, during method development, a UV detector is required after the SPE column to monitor the elution of analyte on the column in order to determine the valve-switching time. As shown in Figure 5, the front shoulder of the Vitamin B<sub>12</sub> peak eluting from the SPE column at 1.0 mL/min ( $v_1$ ) appears at 11.75 min ( $t_{\text{valve-switching } 1}$ ). The peak is detected by the UV detector and the baseline peak width of Vitamin B<sub>12</sub> on the SPE column is 0.25 min ( $w_h$ ). When the flow rate for the separation on the analytical column is 0.5 mL/min ( $v_2$ ), the second valve-switching time of 12.25 min ( $t_{\text{valve-switching } 2}$ ) is calculated using the equation.

Actually, timing must be set shortly before this determined  $t_{\text{valve-switching } 1}$  because 12.25 min is the time point when Vitamin B<sub>12</sub> arrives at the detector. Hence, the switching needs to occur 0.05 min earlier to make sure that the Vitamin B<sub>12</sub> is still completely contained within the SPE column. This time difference is estimated based on the volume of the capillary from the column to the detector and the applied flow rate.

A delay of  $t_{\text{valve-switching } 2}$  in Vitamin B<sub>12</sub> analysis is applied to verify the accuracy of the equation. Comparison of the peak area when  $t_{\text{valve-switching } 1} = 11.70$  min and  $t_{\text{valve-switching } 2} = 12.25$  min (0.8056), to when  $t_{\text{valve-switching } 1} = 11.65$  min and  $t_{\text{valve-switching } 2} = 12.30$  min (0.8065), shows that the equation is accurate for estimating valve-switching time in this on-line SPE mode. In addition, a slightly earlier  $t_{\text{valve-switching } 1}$  and/or delay in  $t_{\text{valve-switching } 2}$  are used to avoid losing analytes in real sample analysis, although this allows more interferences to enter the analytical column.

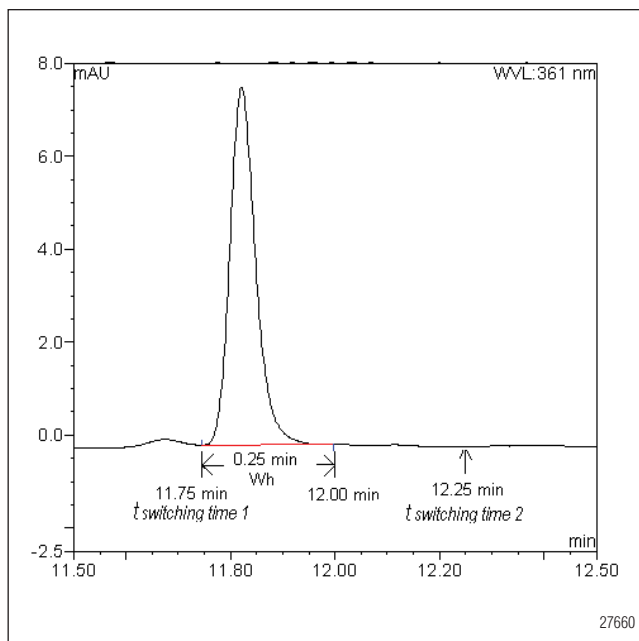

Figure 5. Chromatography used to decide the valve-switching time for the developed on-line SPE mode, based on the configuration shown in Figure 6.

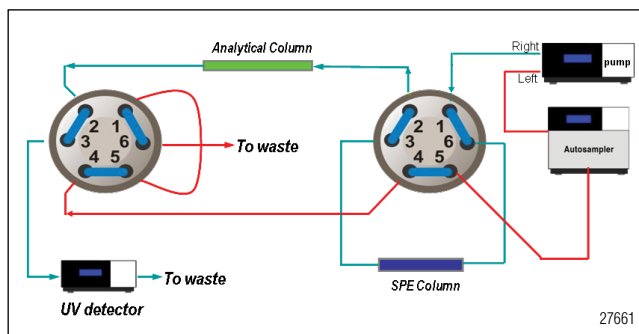

Figure 6. Flow schematic with two 2p to 6p valves as a new mode for development of on-line SPE methods.

Position of Left Valve	Position of Right Valve	Description
1-2	1-2	Determine switching time of right valve during method development
6-1	1-2	Load sample and analysis
6-1	6-1	Transfer analytes from SPE column to analytical column

In practice, an additional 2p to 6p valve may be used to construct a two-valve system for convenient method development. The flow schematic of the two-valve setup is shown in Figure 6. The left valve can be used to switch the SPE column or separation column into the flow path of the detector.

## Discussion of the SPE Method

The effects of the size of the SPE column on the elimination of impurities using the developed on-line SPE mode were investigated. Three Acclaim PA2 columns with different sizes,  $4.6 \times 50$  mm,  $3.0 \times 33$  mm, and  $4.3 \times 10$  mm (guard column), were used for SPE. As shown in Figure 7, the elimination of impurities on the larger column was more efficient, which can be attributed to the separation being more efficient on the larger column than on the smaller one, thereby allowing fewer impurities to enter the analytical flow path. However, the larger SPE column required more time to run the on-line SPE method. Therefore, the selection of the  $3.0 \times 33$  mm column size was a compromise between elimination of impurities and analysis time.

In addition, different SPE columns will use different concentrations of organic solvents to elute Vitamin B<sub>12</sub>. This may cause a change in the retention time of Vitamin B<sub>12</sub> on the separation column; therefore, if a different SPE column is used, the separation conditions on the analytical column also may need to change.

A selectivity difference between the separation column and the SPE column can be used to achieve better separation of Vitamin B<sub>12</sub> and to minimize interferences from the SPE column. This may also involve a difference in the mobile phase between the SPE and separation steps.

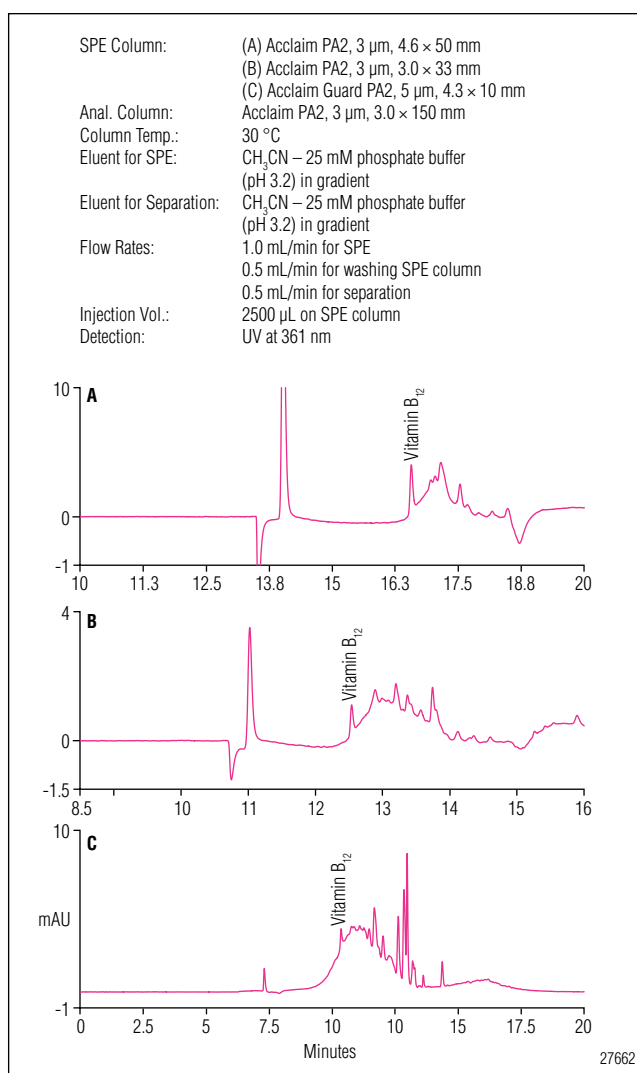

Figure 7. Chromatograms of a beverage sample spiked with 1.5 ng/mL of Vitamin B<sub>12</sub> standard extracted on different SPE columns using the developed on-line SPE mode.

### Reproducibility, Linearity, and Detection Limit

Method reproducibility was estimated by making eight consecutive injections (injection volume 2500  $\mu$ L) of a beverage sample spiked with 0.5 ng/mL of Vitamin B<sub>12</sub> standard. Retention time reproducibility was 0.027% (RSD) and peak area reproducibility was 2.2% (RSD). Figure 8 shows an overlay of chromatograms for the eight consecutive injections.

Calibration linearity for Vitamin B<sub>12</sub> was investigated by using five standard concentrations (0.1, 0.2, 0.5, 1.0, and 5.0 ng/mL). The external standard method was used to establish the calibration curve and to quantify Vitamin B<sub>12</sub> in samples. Excellent linearity was observed from 0.1 to 5.0 ng/mL when plotting the concentration versus the peak area.

The linearity equation of Vitamin B<sub>12</sub> is as follows:

$$A = 0.0686 c - 0.0006$$

The symbol *A* represents peak area and *c* represents Vitamin B<sub>12</sub> concentration (ng/mL). The correlation coefficient (*r*) is 0.9999.

The detection limit for Vitamin B<sub>12</sub> was calculated using the equation:

$$\text{Detection limit} = S t_{(n-1, 1-\alpha=0.99)}$$

The symbol *S* represents Standard Deviation (SD) of replicate analyses, *n* represents number of replicates,  $t_{(n-1, 1-\alpha=0.99)}$  represents Student's value for the 99% confidence level with *n* – 1 degrees of freedom.

Using eight consecutive injections of a beverage sample spiked with 0.5 ng/mL of Vitamin B<sub>12</sub> standard to determine the *S* value, the estimated method detection limit (MDL) was 0.046 ng/mL.

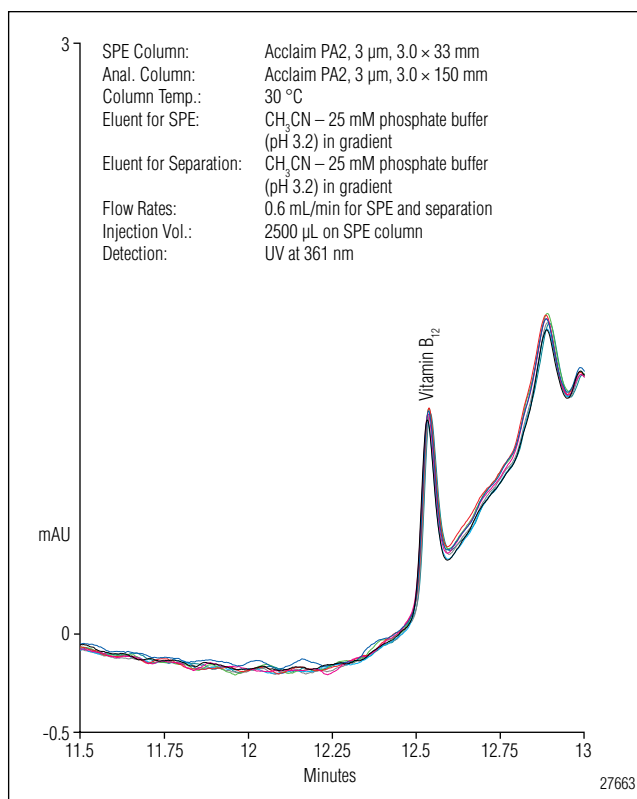

Figure 8. Overlay of chromatograms for eight consecutive injections of a beverage sample spiked with Vitamin B<sub>12</sub> standard (0.5 ng/mL) using the developed on-line SPE mode.

### Sample Analysis

Four types of beverages with different flavors and different product batch numbers were analyzed and the results summarized in Table 4.

**Table 4. Analysis Results for Beverages**

Sample	Batch Number	Detected (μg/100 mL)	Labeled (μg/100 mL)	Added (μg/100 mL)	Found (μg/100 mL)	Recovery %
1 Orange flavor	H22333	0.21	0.1	—	—	—
	H22335	0.20		0.045	0.049	109
2 Litchi flavor	F10014	0.27		—	—	—
	F10632	0.30		0.045	0.046	102
3 Kaffir lime flavor	F10522	0.38		0.045	0.048	107
	F12203	0.37		—	—	—
4 Peach flavor	A31601	0.39		0.045	0.041	91
	A41020	0.36		—	—	—
	C10553	0.0076	0.06–0.18	0.050	0.052	104

Note: 1. Two injections were made for each.

2. Found = Measured value of spiked sample – Measured value of sample.

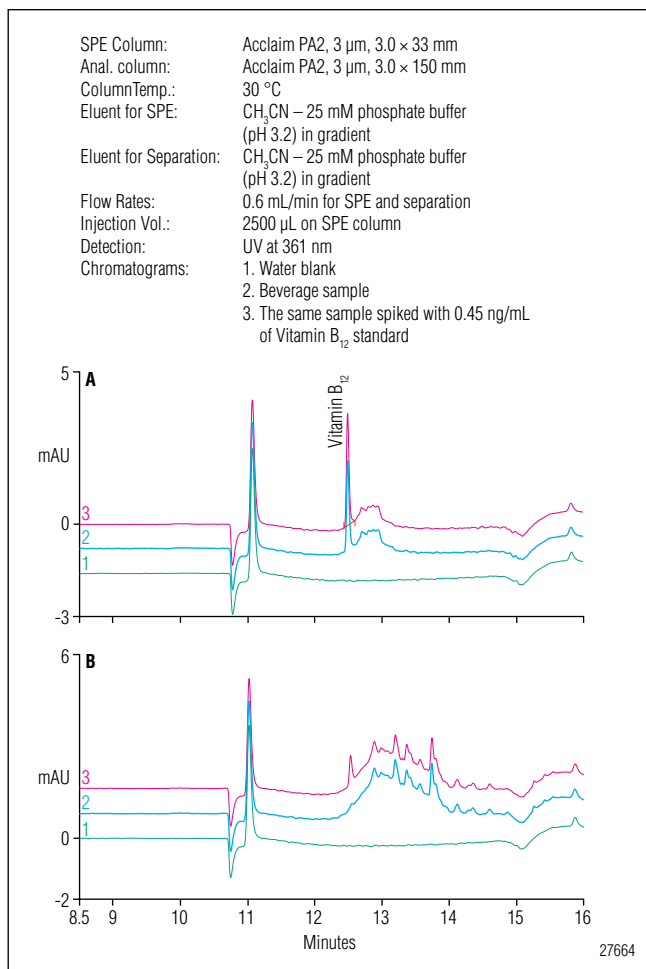

Figure 9. Overlay of chromatograms A) Sample #1 (H22335) and B) Sample #4 (C10553).

Figure 9 shows an overlay of chromatograms of samples #1 and #4, plus the same sample spiked with 0.45 ng/mL of Vitamin B<sub>12</sub> standard. Figure 10 shows chromatograms of samples with different batch numbers.

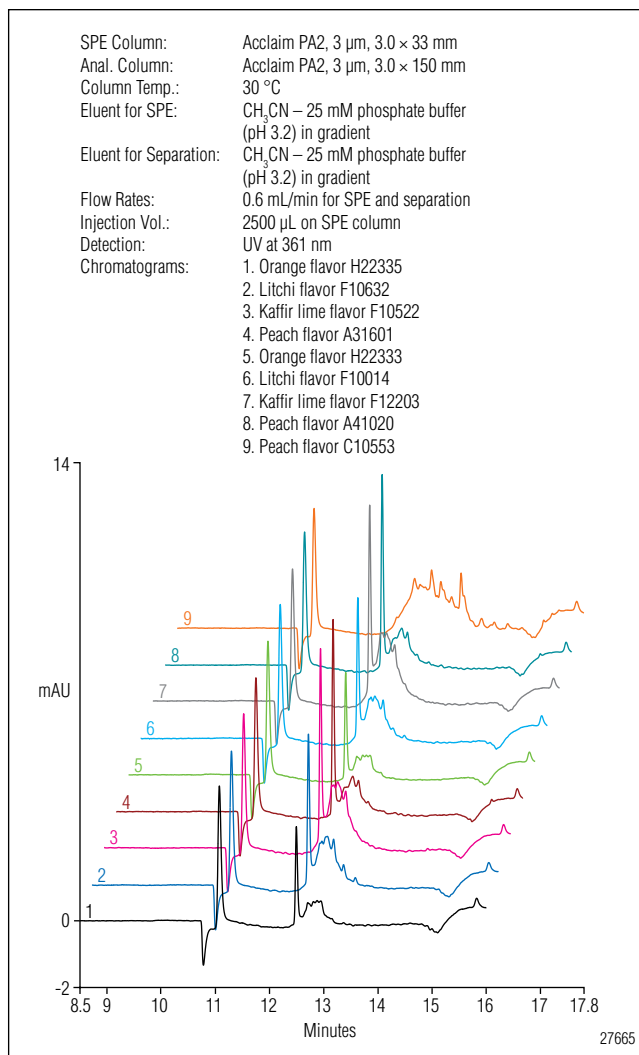

Figure 10. Overlay of chromatograms of beverages with different flavors and different batch numbers.

## Evaluation of a Larger Injection Volume

Typically, a larger-volume sample injection improves the detection sensitivity in on-line SPE; however, more interferences also will be bound to the SPE column, which may result in an overload of the SPE column. So the effects of a larger injection volume ( $> 2500 \mu\text{L}$ ) on this on-line SPE method were estimated. The ratio of peak area was 2.97 and was obtained by injecting  $7500 \mu\text{L}$  (three consecutive injections of  $2500 \mu\text{L}$  using User Defined Program injection mode) of sample spiked with Vitamin B<sub>12</sub> standard, compared to injection of  $2500 \mu\text{L}$  of sample spiked with Vitamin B<sub>12</sub> standard. This ratio of 2.97 was very close to the theoretical value of 3.0.

A comparison of the two injection volumes is shown in Figure 11. There is no evident increase of interferences entering the analytical flow path when using this on-line SPE mode with injection volume  $7500 \mu\text{L}$ . This demonstrates that a larger injection volume of sample may be applied to achieve higher sensitivity when using this on-line SPE method and this particular sample. This type of study must be done with each sample when larger injections are considered because the effect of injection volume on the final chromatogram is likely to depend strongly on the individual sample matrix composition.

## CONCLUSION

This work describes a new and simple design that requires just a small change in the flow scheme of the traditional on-line SPE mode in order to create a full gradient on the SPE column to pre-separate target analytes and then transfer them to the separation column. This new design fully uses the separation power of both columns (rather than performing just enrichment and pre-treatment on the first stationary phase) and may eliminate interferences much more efficiently. The additional dual-valve design is easy to use and convenient for method development. The Dionex UltiMate 3000  $\times 2$  Dual HPLC system provides an efficient platform for this new design and is more convenient than the heart-cut column-switching technique.<sup>11</sup> Sub-ppb concentrations of Vitamin B<sub>12</sub> in beverages were determined with satisfactory results.

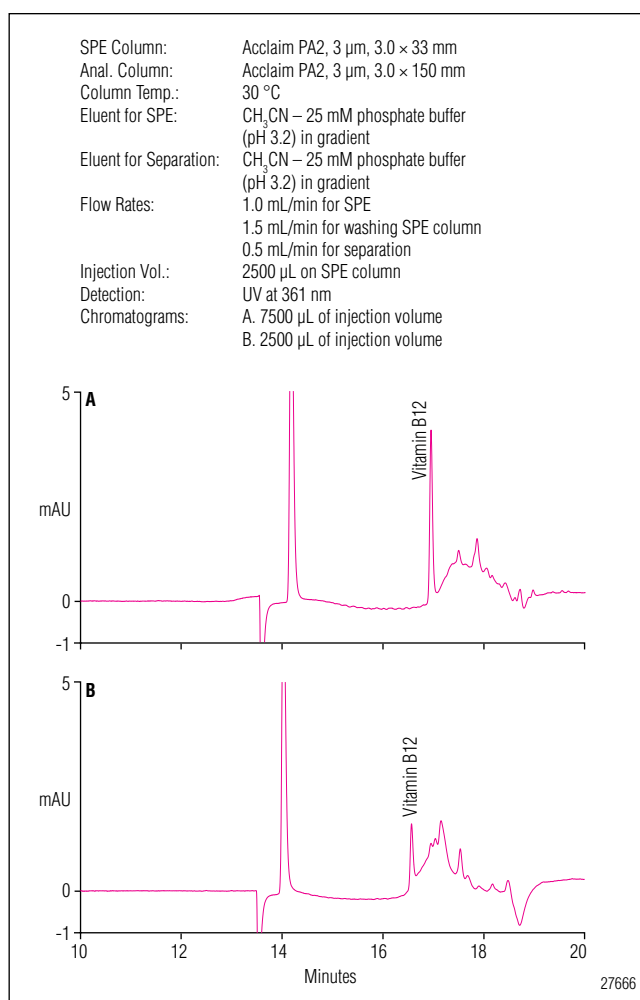

Figure 11. Chromatograms of a beverage sample spiked with Vitamin B<sub>12</sub> standard (1.5 ng/mL) on the SPE column using the developed on-line SPE mode.



---

## REFERENCES

1. Li, H.B.; Chen, F.; Jiang Y. Determination of Vitamin B<sub>12</sub> in Multivitamin Tablets and Fermentation Medium by High-Performance Liquid Chromatography with Fluorescence Detection. *J. Chromatogr., A*, **2000**, *891*, 243.
2. Luo, X.B.; Chen, B.; Ding, L.; Tang, F.; Yao, S.Z. HPLC-ESI-MS Analysis of Vitamin B<sub>12</sub> in Food Products and in Multivitamins-Multimineral Tablets. *Anal. Chim. Acta* **2006**, *562*, 185.
3. Honda, K.; Imanishi, M.; Takeda, T.; Kimura, M. Determination of Vitamin B<sub>12</sub> in Serum by HPLC/ICP-MS. *Anal. Sci.*, **2001**, *17 (Suppl.)*, 983.
4. Hao, Y.P.; Jiang, J.D.; Fang, Y.G. Determination of Vitamin B<sub>12</sub> in Composite Vitamin Additives for Milk Powder and Formula by HPLC. *China Food Additives* **2004**, (2), 1.
5. Wongyai, S. Determination of Vitamin B<sub>12</sub> in Multivitamin Tablets by Multimode High-Performance Liquid Chromatography. *J. Chromatogr., A* **2000**, *870*, 217.
6. *Food Analysis by HPLC*; Nollet, Leo M.L., Ed., Marcel Dekker, Inc.: New York, Basel, 2000; 2nd Edition; p 449.
7. Dionex Corporation, *Determination of Phenols in Drinking and Bottled Mineral Waters Using On-Line Solid-Phase Extraction Followed by HPLC with UV Detection*. Application Note 191, LPN 1949, 2008, Sunnyvale, CA.
8. Dionex Corporation, *Determination of Polycyclic Aromatic Hydrocarbons (PAHs) in Edible Oils by Donor-Acceptor Complex Chromatography (DACC)-HPLC with Fluorescence Detection*. Application Note 196, LPN 1998, 2008, Sunnyvale, CA.
9. Dionex Corporation, *Determination of Polycyclic Aromatic Hydrocarbons (PAHs) in Tap Water Using On-Line Solid-Phase Extraction Followed by HPLC with UV and Fluorescence Detections*. Application Note 213, LPN 2128, 2009, Sunnyvale, CA.
10. Sun, Q.L.; Zhuang, S.Q. *Determination of Vitamin B<sub>12</sub> Using UPLC*; Application Summary for Waters Corporation, 2010.
11. Villasenor, S.R. Matrix Elimination in Liquid Chromatography Using Heart-Cut Column Switching Techniques. *Anal. Chem.* **1991**, *63*, 1362.

---

## Column Selection Guide

---



# Silica Columns

		Reversed-Phase (RP)		Mixed-Mode		HILIC		Application-Specific				Example Applications							
		Acclaim 120 C18	Acclaim 120 C8	Acclaim 300 C18	Acclaim Polar Advantage (PA)	Acclaim Polar Advantage II (PA2)	Acclaim Phenyl-1	Acclaim Trinity P1	Acclaim Mixed-Mode WAX-1	Acclaim Mixed-Mode WCX-1	Acclaim Mixed-Mode HILIC-1		Acclaim HILIC-10	Acclaim Organic Acid	Acclaim Surfactant	Acclaim Explosives E1	Acclaim Explosives E2	Acclaim Carbamate	
General Applications	Neutral Molecules	High hydrophobicity	✓	✓	✓	✓	✓	✓	✓	✓	✓							Fat-soluble vitamins, PAHs, glycerides	
		Intermediate hydrophobicity	✓	✓	✓	✓	✓	✓	✓	✓	✓	✓							Steroids, phthalates, phenolics
		Low hydrophobicity	✓			✓	✓					✓	✓						Acetaminophen, urea, polyethylene glycols
	Anionic Molecules	High hydrophobicity	✓	✓	✓	✓	✓	✓	✓	✓	✓	✓							NSAIDs, phospholipids
		Intermediate hydrophobicity	✓	✓	✓	✓	✓	✓	✓	✓	✓	✓							Asprin, alkyl acids, aromatic acids
		Low hydrophobicity				✓			✓	✓		✓	✓						Small organic acids, e.g. acetic acids
	Cationic Molecules	High hydrophobicity	✓	✓	✓	✓	✓	✓		✓	✓	✓							Antidepressants
		Intermediate hydrophobicity	✓	✓	✓	✓	✓	✓	✓		✓	✓							Beta blockers, benzidines, alkaloids
		Low hydrophobicity	✓			✓			✓		✓	✓	✓						Antacids, pseudoephedrine, amino sugars
	Amphoteric/ Zwitterionic Molecules	High hydrophobicity	✓	✓	✓	✓	✓	✓	✓	✓	✓	✓							Phospholipids
		Intermediate hydrophobicity	✓	✓	✓	✓	✓	✓			✓								Amphoteric surfactants, peptides
		Low hydrophobicity				✓	✓		✓	✓	✓	✓	✓						Amino acids, aspartame, small peptides
	Mixtures of Neutral, Anionic, Cationic Molecules	Neutrals and acids	✓			✓	✓		✓	✓									Artificial sweeteners
		Neutrals and bases	✓			✓	✓		✓		✓								Cough syrup
		Acids and bases				✓			✓										Drug active ingredient with counterion
		Neutrals, acids, and bases				✓			✓										Combination pain relievers
Specific Applications	Surfactants	Anionic	✓	✓	✓	✓	✓							✓				SDS, LAS, laureth sulfates	
		Cationic												✓				Quats, benzylalkonium in medicines	
		Nonionic	✓	✓	✓	✓	✓				✓			✓				Triton X-100 in washing tank	
		Amphoteric	✓	✓	✓	✓	✓							✓					Cocoamidopropyl betaine
		Hydrotropes												✓					Xylenesulfonates in handsoap
		Surfactant blends												✓					Noionic and anionic surfactants
	Organic Acids	Hydrophobic							✓	✓			✓						Aromatic acids, fatty acids
		Hydrophilic							✓	✓			✓						Organic acids in soft drinks, pharmaceuticals
	Environmental Contaminants	Explosives													✓	✓			U.S. EPA Method 8330, 8330B
		Carbonyl compounds														✓			U.S. EPA 1667, 555, OT-11; CA CARB 1004
		Phenols	✓			✓													Compounds regulated by U.S. EPA 604
		Chlorinated/Phenoxy acids				✓													U.S. EPA Method 555
		Triazines	✓			✓													Compounds regulated by U.S. EPA 619
		Nitrosamines				✓													Compounds regulated by U.S. EPA 8270
		Benzidines	✓			✓													U.S. EPA Method 605
		Perfluorinated acids				✓													Dionex TN73
Microcystins		✓																ISO 20179	
Isocyanates						✓					✓							U.S. OSHA Methods 42, 47	
Carbamate insecticides																	✓	U.S. EPA Method 531.2	
Vitamins	Water-soluble vitamins				✓	✓		✓										Vitamins in dietary supplements	
	Fat-soluble vitamins	✓	✓	✓	✓	✓	✓		✓									Vitamin pills	
Pharmaceutical Counterions	Anions							✓	✓									Inorganic anions and organic acids in drugs	
	Cations							✓		✓								Inorganic cations and organic bases in drugs	
	Mixture of Anions and Cations							✓										Screening of pharmaceutical counterions	
	API and counterions							✓										Naproxen Na <sup>+</sup> salt, metformin Cl <sup>-</sup> salt, etc.	



# Column Specifications

## IC Anion Columns

Column	Format	Primary Eluent	Application	Particle Diameter	Substrate Crosslinking	Latex Diameter	Latex Crosslinking	Capacity (per column)	Functional Group	Hydrophobicity
IonPac AS24	2 × 250 mm	Hydroxide	Recommended column for haloacetic acids prior to MS or MS/MS detection	7 µm	55%	-	-	140 µeq	Alkanol quaternary ammonium	Ultralow
IonPac AS23	2 × 250 mm 4 × 250 mm	Carbonate	Recommended column for inorganic anions and oxyhalides. Trace bromate in drinking water.	6 µm	55%	-	-	80 µeq 320 µeq	Alkyl quaternary ammonium	Ultralow
IonPac AS22	2 × 250 mm 4 × 250 mm	Carbonate	Recommended column for fast analysis of common inorganic anions.	6.5 µm	55%	-	-	52.5 µeq 210 µeq	Alkyl quaternary ammonium	Ultralow
IonPac AS21	2 × 250 mm	Hydroxide	Recommended column for trace perchlorate prior to MS or MS/MS detection	7.0 µm	55%	-	-	45 µeq	Alkanol quaternary ammonium	Ultralow
IonPac AS20	2 × 250 mm 4 × 250 mm	Hydroxide	Recommended column for trace perchlorate prior to suppressed conductivity detection.	7.5 µm	55%	-	-	77.5 µeq 310 µeq	Alkanol quaternary ammonium	Ultralow
IonPac AS19	2 × 250 mm 4 × 250 mm	Hydroxide	Recommended column for inorganic anions and oxyhalides. Trace bromate in drinking water.	7.5 µm	55%	-	-	60 µeq 350 µeq	Alkanol quaternary ammonium	Low
IonPac AS18	2 × 250 mm 4 × 250 mm	Hydroxide	Recommended column for the analysis of common inorganic anions.	7.5 µm	55%	65 nm	8%	75 µeq 285 µeq	Alkanol quaternary ammonium	Low
IonPac AS17-C	2 × 250 mm 4 × 250 mm	Hydroxide	Trace anions in HPW matrices. Carboxylated resin, no sulfate blank. Low capacity for fast analysis of common inorganic anions using gradient elution with the Eluent Generator.	10.5 µm	55%	75 nm	6%	7.5 µeq 30 µeq	Alkanol quaternary ammonium	Low
IonPac AS16	2 × 250 mm 4 × 250 mm	Hydroxide	High capacity for hydrophobic anions including iodide, thiocyanate, thiosulfate, and perchlorate. Polyvalent anions including: polyphosphates and polycarboxylates	9 µm	55%	80 nm	1%	42.5 µeq 170 µeq	Alkanol quaternary ammonium	Ultralow
IonPac AS15	2 × 250 mm 4 × 250 mm	Hydroxide	High capacity for trace analysis of inorganic anions and low molecular weight organic acids in high purity water matrices.	9 µm	55%	-	-	56.25 µeq 225 µeq	Alkanol quaternary ammonium	Medium-High
IonPac AS15-5mm	3 × 150 mm	Hydroxide	Fast run, high capacity for trace analysis of inorganic anions and low molecular weight organic acids in high purity water matrices.	5 µm	55%	-	-	70 µeq	Alkanol quaternary ammonium	Medium-High
IonPac AS14A-5 µm	3 × 150 mm	Carbonate	Recommended column for fast analysis of common inorganic anions.	5 µm	55%	-	-	40 ueq	Alkyl quaternary ammonium	Medium
IonPac AS14A	4 × 250 mm	Carbonate	For analysis of common inorganic anions.	7 µm	55%	-	-	120 µeq	Alkyl quaternary ammonium	Medium
IonPac AS14	2 × 250 mm 4 × 250 mm	Carbonate	Moderate capacity for fast analysis of common inorganic anions.	9 µm	55%	-	-	16 µeq 65 µeq	Alkyl quaternary ammonium	Medium-High

Column	Format	Primary Eluent	Application	Particle Diameter	Substrate Crosslinking	Latex Diameter	Latex Crosslinking	Capacity (per column)	Functional Group	Hydrophobicity
IonPac AS12A	2 × 200 mm 4 × 200 mm	Carbonate	Moderate capacity for analysis of inorganic anions and oxyhalides. Trace chloride and sulfate in high carbonate matrices.	9 µm	55%	140 nm	0.20%	13 µeq 52 µeq	Alkyl quaternary ammonium	Medium
IonPac AS11-HC	2 × 250 mm 4 × 250 mm	Hydroxide	High capacity for the determination of organic acids and inorganic anions in uncharacterized samples.	9 µm	55%	70 nm	6%	72.5 µeq 290 µeq	Alkanol quaternary ammonium	Medium-Low
IonPac AS11	2 × 250 mm 4 × 250 mm	Hydroxide	Low capacity for fast profiling of organic acids and inorganic anions in well-characterized samples.	13 µm	55%	85 nm	6%	11 µeq 45 µeq	Alkanol quaternary ammonium	Very Low
IonPac AS10	2 × 250 mm 4 × 250 mm	Hydroxide	High capacity for the analysis of inorganic anions and organic acids in high nitrate samples.	8.5 µm	55%	65 nm	5%	42.5 µeq 170 µeq	Alkyl quaternary ammonium	Low
IonPac AS9-HC	2 × 250 mm 4 × 250 mm	Carbonate	High-capacity column for inorganic anions and oxyhalides. Trace bromate in drinking water.	9 µm	55%	90 nm	18%	48 µeq 190 µeq	Alkyl quaternary ammonium	Medium-Low
IonPac AS9-SC	4 × 250 mm	Carbonate	Low capacity for fast analysis of inorganic anions and oxyhalides. Specified column in US EPA Method 300.0 (B).	13 µm	55%	110 nm	20%	30-35 µeq	Alkyl quaternary ammonium	Medium-Low
IonPac AS4A-SC	2 × 250 mm 4 × 250 mm	Carbonate	Low capacity for fast analysis of common inorganic anions. Specified column in U.S. EPA Method 300.0 (A).	13 µm	55%	160 nm	0.50%	5 µeq 20 µeq	Alkanol quaternary ammonium	Medium-Low
IonPac Fast Anion IIIA	3 × 250 mm	Hydroxide	Recommended column for phosphoric and citric acids in cola soft drinks.	7.5 µm	55%	-	-	55 µeq	Alkanol quaternary ammonium	Ultralow
IonPac AS7	4 × 250 mm	Specialty Eluents	Polyvalent anions including chelating agents, polyphosphates and polyphosphonates. Cyanide, sulfide, hexavalent chromium, and arsenic speciation.	10 µm	2%	530 nm	5%	100 µeq	Alkyl quaternary ammonium	Medium-High
IonPac AS5A	4 × 150 mm	Hydroxide	Low capacity for fast profiling of organic acids and inorganic anions in well-characterized samples.	5 µm	2%	60 nm	4%	35 µeq	Alkanol quaternary ammonium	Low
IonPac AS5	4 × 250 mm	Hydroxide	Metal-EDTA complexes, metal-cyanide complexes, and oxyanions.	15 µm	2%	120 nm	1%	20 µeq	Alkanol quaternary ammonium	Low

## IC Cation Columns

Column	Format	Primary Eluent	Application	Particle Diameter	Substrate Crosslinking	Latex Diameter	Latex Crosslinking	Capacity (per column)	Functional Group	Hydrophobicity
IonPac CS18	2 × 250 mm	MSA	Recommended column for polar amines (alkanolamines and methylamines) and moderately hydrophobic and polyvalent amines (biogenic and diamines). Nonsuppressed mode when extended calibration linearity for ammonium and weak bases is required	6 µm	55%	-	-	0.29 µeq	Carboxylic acid	Medium
IonPac CS17	2 × 250 mm 4 × 250 mm	MSA	Recommended column for hydrophobic and polyvalent amines (biogenic amines and diamines)	7 µm	55%	-	-	0.363 µeq 1.45 µeq	Carboxylic acid	Very Low
IonPac CS16	3 × 250 mm 5 × 250 mm	MSA	Recommended column for disparate concentration ratios of adjacent-eluting cations such as sodium and ammonium. Can be used for alkylamines and alkanolamines.	5 µm	55%	-	-	3.0 µeq 8.4 µeq	Carboxylic acid	Medium
IonPac CS15	2 × 250 mm 4 × 250 mm	MSA	Disparate concentration ratios of ammonium and sodium. Trace ethanolamine in high-ammonium or high-potassium concentrations. Alkanolamines.	8.5 µm	55%	-	-	0.7 µeq 2.8 µeq	Carboxylic acid/ phosphonic acid/ crown ether	Medium
IonPac CS14	2 × 250 mm 4 × 250 mm	MSA	Aliphatic amines, aromatic amines, and polyamines plus mono- and divalent cations.	8.5 µm	55%	-	-	0.325 µeq 1.3 µeq	Carboxylic acid	Low
IonPac CS12A-MS	2 × 100 mm	MSA	IC-MS screening column for fast elution and low flow rates required for interfacing with IC-MS	8.5 µm	55%	-	-	0.28 µeq	Carboxylic acid/ phosphonic acid	Medium
IonPac CS12A-5 µm	3 × 150 mm	MSA	Recommended column for high efficiency and fast analysis (3 min) of mono- and divalent cations.	5 µm	55%	-	-	0.94 µeq	Carboxylic acid/ phosphonic acid	Medium
IonPac CS12A	2 × 250 mm 4 × 250 mm	MSA	Recommended column for the separation of mono- and divalent cations. Manganese morpholine, alkylamines, and aromatic amines.	8.5 µm	55%	-	-	0.7 µeq 2.8 µeq	Carboxylic acid/ phosphonic acid	Medium
IonPac CS11	2 × 250 mm	HCl + DAP	Separation of mono- and divalent cations. Ethanolamines if divalent cations are not present.	8 µm	55%	200 nm	5%	0.035 µeq	Sulfonic acid	Medium
IonPac CS10	4 × 250 mm	HCl + DAP	Separation of mono- and divalent cations.	8.5 µm	55%	200 nm	5%	0.08 µeq	Sulfonic acid	Medium
IonPac CS5A	2 × 250 mm 4 × 250 mm	Pyridine dicarboxylic acid	Recommended column for transition and lanthanide metals analysis. Aluminum analysis.	9 µm	55%	140 nm 75 nm	10% 20%	0.02 µeq/ 0.005 µeq/ 0.04 µeq/ 0.01 µeq	Sulfonic acid/ alkanol quaternary ammonium	-

## Ion-Exclusion Columns

Column	Format	Primary Eluent	Application	Particle Diameter	Substrate Crosslinking	Latex Diameter	Latex Crosslinking	Capacity (per column)	Functional Group	Hydrophobicity
IonPac ICE-AS1	4 × 250 mm 9 × 250 mm	Heptafluorobutyric acid	Organic acids in high ionic strength matrices. Fast separation of organic acids.	7.5 µm	8%	-	-	5.3 µeq 27 µeq	Sulfonic acid	Ultra Low
IonPac ICE-AS6	9 × 250 mm	Heptafluorobutyric acid	Organic acids in complex or high ionic strength matrices.	8 µm	8%	-	-	27 µeq	Sulfonic and carboxylic acid	Moderate
IonPac ICE-Borate	9 × 250 mm	MSA/ Mannitol	Trace concentrations of borate	7.5 µm	8%	-	-	27 µeq	Sulfonic acid	Ultra Low

## Acclaim General and Specialty Columns

Column	Bonded Phase	USP Type	Endcapped	Substrate	Particle Shape	Particle Size	Metal Impurity (ppm) Na, Fe, AL	Average Pore Diameter	Surface Area (m <sup>2</sup> /g)	Total Carbon Content
Mixed-Mode WAX	Proprietary alkyl amine	na	Proprietary	Ultrapure silica	Spherical	5 µm	<10 ppm	120 Å	300	na
Mixed-Mode HILIC	Proprietary alkyl diol	na	Proprietary			5 µm		120 Å	300	na
Mixed-Mode WCX	Proprietary alkyl carboxyl	na	Proprietary			5 µm		120 Å	300	na
Organic Acid (OA)	Proprietary	na	Yes			5 µm		120 Å	300	17%
Surfactant and Explosives E1/2	Proprietary	na	Yes			5 µm		120 Å	300	na
120 C18	C18	L1	Yes			2, 3 and 5 µm		120 Å	300	18%
120 C8	C8	L7	Yes			3 and 5 µm		120 Å	300	11%
300 C18	C18	L1	Yes			3 µm		300 Å	100	7%
Polar Advantage	Sulfamido C16	na	Yes			3 and 5 µm		120 Å	300	17%
Polar Advantage II	Amide C18	na	Yes			2, 3 and 5 µm		120 Å	300	17%
HILIC	Proprietary hydrophilic		Yes			3 µm		120 Å	300	
Phenyl-1	Proprietary alkyl phenyl		Yes			3 µm		120 Å	300	
Carbamate	Proprietary alkyl group		Yes			3 and 5 µm		120 Å	300	
Trinity			Yes					120 Å	300	

## Bio Columns

### Protein

Column	Phase	Target Applications	Base Matrix Material	Substrate Crosslinking	Capacity	Recommended Flow Rate	Solvent Compatibility	Maximum Backpressure	pH Range
MABPac SEC-1									
MABPac SCX-10									
ProPac WCX-10	Weak Cation Exchange	High resolution and high efficiency separations of proteins and glycoproteins, pI =3-10, MW>10,000 units	10-µm diameter nonporous substrate to which is grafted a polymer chain bearing carboxylate groups.	55%	6 mg/ mL lysozyme	0.2–2 mL/min	80% ACN, acetone. Incompatible with alcohols and MeOH	3000 psi (21 MPa)	2–12.0
ProPac SCX-10	Strong Cation Exchange	High resolution and high efficiency separations of proteins and glycoproteins, pI =3-10, MW>10,000 units	10 µm diameter nonporous substrate to which is grafted a polymer chain bearing sulfonate groups.	55%	3 mg/ mL lysozyme	0.2–2.0 mL/min	80% ACN, acetone, MeOH	3000 psi (21 MPa)	2–12.0
ProPac SCX-20									
ProPac WAX-10	Weak Anion Exchange	High resolution and high efficiency separations of proteins and glycoproteins, pI =3-10, MW>10,000 units	10 µm diameter non-porous substrate to which is grafted a polymer chain bearing tertiary amine groups.	55%	5 mg/ mL BSA/ mL	0.2–2.0 mL/min	80% ACN, acetone, MeOH,	3000 psi (21 MPa)	2–12.0
ProPac SAX-10	Strong Anion Exchange	High resolution and high efficiency separations of proteins and glycoproteins, pI =3-10, MW>10,000 units	10 µm diameter non-porous substrate with grafted polymer chain bearing quaternary ammonium groups.	55%	15 mg/ mL BSA	0.2–2.0 mL/min	80% ACN, acetone, MeOH	3000 psi (21 MPa)	2–12.0
ProSwift RP-1S	Reversed-Phase	Fast protein separation with high capacity using Reversed Phase	Monolith; polystyrene-divinylbenzene with phenyl functional group	Monolith Standard permeability	5.5 mg/mL Insulin	2–4 mL/min	Most common organic solvents	2800 psi (19.2 Mpa)	1–14
ProSwift RP-2H	Reversed-Phase	Fast protein separation with high capacity using Reversed Phase	Monolith; polystyrene-divinylbenzene with phenyl functional group	Monolith High permeability	1.0 mg/mL Lysozyme	1–10 mL/min	Most common organic solvents	2800 psi (19.3 Mpa)	1–14
ProSwift RP-4H									
ProSwift RP-3U	Reversed-Phase	Fast protein separation with high capacity using Reversed Phase	Monolith; polystyrene-divinylbenzene with phenyl functional group	Monolith Ultrahigh permeability	0.5 mg/mL Lysozyme	1– 16 mL/min	Most common organic solvents	2800 psi (19.3 Mpa)	1–14
ProSwift SAX-1S	Strong Anion Exchange	Fast protein separation with good resolution using Anion Exchange	Monolith; polymethacrylate with quaternary amine functional group	Monolith Standard permeability	18 mg/mL BSA	0.5–1.5 (4.6 mm), 0.05–.25 (1.0 mm)	Most common organic solvents	1000 psi (4.6 mm) 2000 psi (1.0 mm)	2–12.0
ProSwift SCX-1S	Strong Cation Exchange	Fast protein separation with good resolution using Cation Exchange	Monolith; polymethacrylate with sulfonic acid functional group	Monolith Standard permeability	30 mg/mL Lysozyme	0.5–1.5 mL/min (4.6 mm)	Most common organic solvents	1000 psi (4.6 mm)	2–12.0

Column	Phase	Target Applications	Base Matrix Material	Substrate Crosslinking	Capacity	Recommended Flow Rate	Solvent Compatibility	Maximum Backpressure	pH Range
ProSwift WAX-1S	Weak Anion Exchange	Fast protein separation with good resolution using Anion Exchange	Monolith; polymethacrylate with tertiary amine (DEAE) functional group	Monolith Standard permeability	18 mg/mL BSA	0.5–1.5 mL/min (4.6 mm), 0.05–.25 (1.0 mm)	Most common organic solvents	1000 psi (4.6 mm) 2000 psi (1.0 mm)	2–12.0
ProSwift WCX-1S	Weak Cation Exchange	Fast protein separation with good resolution using Cation Exchange	Monolith; polymethacrylate with carboxylic acid (CM) functional group	Monolith Standard permeability	23 mg/mL Lysozyme	0.5–1.5 mL/min (4.6 mm), 0.05–.20 (1.0 mm)	Most common organic solvents	1000 psi (4.6 mm) 2000 psi (1.0 mm)	2–12.0
ProPac IMAC-10	Immobilized Metal Affinity	High resolution separation of certain metal-binding proteins and peptides	10 µm diameter non-porous polystyrene divinylbenzene substrate with poly (IDA) grafts.	55%	>60 mg lysozyme/ mL gel (4 x 250 mm)	1.0 mL/min	EtOH, urea, NaCl, non- ionic detergents, glycerol, acetic acid, guanidine HCl	3000 psi (21MPa)	2–12
ProSwift ConA-1S									
ProPac HIC-10	Reversed-Phase	Protein separation using hydrophobic interaction with salt gradient elution	Spherical 5 µm, ultrapure silica, 300 Å, surface area 100 m <sup>2</sup> / g,	n/a	340 mg lysozyme per 7.8 x 75 mm column	1.0 mL/ min	2M Ammonium sulfate/ phosphate salts, organic solvent for cleanup	4,000 psi	2.5–7.5

## Carbohydrate

Column	Target Applications	Base Matrix Material	Substrate Crosslinking	Latex Crosslinking	Capacity	Recommended Eluents	Recommended Flow Rate	Solvent Compatibility	Maximum Backpressure	pH Range
CarboPac MA1	Reduced mono- and disaccharide analysis.	7.5 µm diameter macroporous substrate fully functionalized with an alkyl quaternary ammonium group	15%	No latex	1450 µeq (4 × 250 mm)	Hydroxide	0.4 mL/min	0%	2000 psi (14 MPa)	0–14
CarboPac PA1	General purpose mono-, di-, and oligosaccharide analysis	10 µm diameter nonporous substrate agglomerated with a 500 nm MicroBead quaternary ammonium functionalized latex	2%	5%	100 µeq (4 × 250 mm)	Hydroxide, acetate/hydroxide	1.0 mL/min	0–5%	4000 psi (28 MPa)	0–14
CarboPac PA10	Monosaccharide compositional analysis	10 µm diameter nonporous substrate agglomerated with a 460 nm MicroBead di-functionalized latex	55%	5%	100 µeq (4 × 250 mm)	Hydroxide, acetate/hydroxide	1.0 mL/min	0–90%	3500 psi (24.5 MPa)	0–14
CarboPac PA20	Fast mono-, and disaccharide analysis	6.5 µm diameter nonporous substrate agglomerated with a 130 nm MicroBead quaternary ammonium functionalized latex	55%	5%	65 µeq (3 × 150 mm)	Hydroxide, acetate/hydroxide	0.5 mL/min	0–100%	3000 psi (21 MPa)	0–14
CarboPac PA100	Oligosaccharide mapping and analysis	8.5 µm diameter nonporous substrate agglomerated with a 275 nm MicroBead di-functionalized latex	55%	6%	90 µeq (4 × 250 mm)	Hydroxide, acetate/hydroxide	1.0 mL/min	0–90%	4000 psi (28 MPa)	0–14
CarboPac PA200	High resolution oligosaccharide mapping and analysis	5.5 µm diameter nonporous substrate agglomerated with a 43 nm MicroBead quaternary ammonium functionalized latex	55%	6%	35 µeq (3 × 250 mm)	Hydroxide, acetate/hydroxide	0.5 mL/min	0–100%	4000 psi (28 MPa)	0–14

## DNA

Column	Target Applications	Base Matrix Material	Substrate Crosslinking	Latex Crosslinking	Capacity	Recommended Eluents	Recommended Flow Rate	Solvent Compatibility	Max. Backpressure	pH Range
DNAPac PA100	Single stranded DNA or RNA oligonucleotides, restriction fragments, glycoprotein isoforms.	13-µm diameter nonporous substrate agglomerated with a 100-nm MicroBead alkyl quaternary ammonium functionalized latex.	55%	5%	40 µeq	Chloride, acetate, bromide, perchlorate: in lithium sodium or ammonium forms	1.5 mL/min	0–100%	4000psi (28MPa)	2–12.5
DNAPac PA200	High resolution single stranded DNA or RNA oligonucleotides, restriction fragments, glycoprotein isoforms.	8-µm diameter nonporous substrate agglomerated with a 130-nm MicroBead alkyl quaternary ammonium functionalized latex.	55%	5%	40 µeq	Chloride, acetate, bromide, perchlorate: in lithium sodium or ammonium forms	1.2 mL/min	0–100%	4000psi (28MPa)	2–12.5
DNASwift										



AccuStandard is a trademark of AccuStandard Inc.  
Acrodisc is a registered trademark of Pall Corporation.  
Anke is a registered trademark of Anting Scientific Instrumental Factory.  
Anotop is a trademark of Whatman.  
BD and Bacto are trademarks of Becton, Dickinson, and Company.  
Bigelow is a registered trademark of R.C. Bigelow, Incorporated.  
Diet Rite is a registered trademark of Royal Crown Company, Inc.  
Enfamil is a registered trademark of Bristol-Myers Squibb Co., Mead Johnson Nutritionals.  
Good Start and Alsoy are registered trademarks of Nestle USA, Inc., Nutrition Division.  
IKA is a registered trademark of IKA Works.  
Kudos is a registered trademark of Kudos Ultrasonic Instrumental Company.  
Lipton is a registered trademark of the Unilever Group of Companies.  
MICRO DIST is a trademark of Lachat Instruments, a Hach Company.  
Milli-Q and Millex are registered trademarks of Millipore Corporation.  
Minute Maid is a registered trademark of the Coca-Cola Company.  
PEEK is a trademark of Victrex PLC.  
Phenomenex is a trademark of Phenomenex, Inc.  
Pyrex is a registered trademark of Corning Glass Works.  
Similac and Isomil are registered trademarks of Abbott Laboratories, Ross Products Division.  
Splenda is a registered trademark of McNeil-PPC, Inc.  
Strata is a trademark of Shine Technology.  
Supnett is a registered trademark of Nutrinova.  
Supelcosil is a trademark of Sigma-Aldrich Co.  
SUPELCOWAX 10 is a trademark of Supelco, Inc.  
Teflon is a registered trademark of E. I. du Pont de Nemours.  
TurboVap is a registered trademark of Caliper Life Sciences.  
ULTREX is a registered trademark of J.T. Baker.

All other trademarks are the property of Thermo Fisher Scientific Inc. and its subsidiaries.

©2012 Thermo Fisher Scientific, Inc. All rights reserved.

*This information is not intended to encourage use of these products in any manners that might infringe the intellectual property rights of others.*

**Dionex Products:** 1228 Titan Way, PO Box 3603, Sunnyvale, CA 94088-3603, (408) 737-0700  
**North America:** U.S./Canada (847) 295-7500  
**South America:** Brazil (55) 11 3731 5140  
**Europe:** Austria (43) 616 51 25, Benelux (31) 20 683 9768 (32) 3 353 4294  
Denmark (45) 36 36 90 90, France (33) 1 39 30 01 10, Germany (49) 61125 991 0  
Ireland (353) 644 0064, Italy (39) 02 51 62 1267, Sweden (46) 8 473 3380,  
Switzerland (41) 62 205 9966, United Kingdom (44) 1276 691722  
**Asia Pacific:** Australia (61) 2 9420 5233, China (852) 2428 3282, India (91) 22 2764 2735,  
Japan (81) 6885 1213, Korea (82) 2 2653 2580, Singapore (65) 6289 1190,  
Taiwan (886) 2 875 6655

[www.thermoscientific.com/dionex](http://www.thermoscientific.com/dionex)

LPN 3083 02/12

Now sold under the  
Thermo Scientific brand

**Thermo**  
SCIENTIFIC