

ASTM D 4815 – the Determination of Oxygenated Compounds in Gasoline

Application Note

Energy & Fuels

Authors

David Case and Matt Stevens
Agilent Technologies, Inc.

Introduction

With the arrival of reformulated gasoline as mandated by the EPA and the California Air Resources Board (CARB), petroleum refiners have had to incorporate some form of oxygen-containing component in the gasoline they produce. The model on which the regulations are based requires 2.0% by weight of oxygen in reformulated gasoline. Both refiners and regulators have had to insure that this requirement is met by the addition of certain compounds to the gasoline blend. Most of these compounds take the form of aliphatic alcohols or ethers, such as ethanol and t-butyl-methyl ether (MTBE). To quantify these oxygenated additives, CARB has designated ASTM D 4815 as the test method for all reformulated gasoline sold in California.

Agilent has designed a system that performs the analysis according to ASTM D 4815. The configured system tests all finished motor gasolines for the oxygenated compounds as listed in the ASTM method.



Agilent Technologies

Instrumentation

The system consists an Agilent GC equipped with two columns, a model 1079 split/splitless injector, a ten-port rotary valve, and a single FID detector. The first column (Agilent J&W CP-TCEP for Alcohols in Gasoline) pre-separates the low boiling and non-polar components from the higher boiling and polar components. The alcohols, ethers, and high-boiling components are back flushed into the second column (Agilent J&W CP-Sil 5 CB) where they are separated by boiling point order. The system utilizes electronic control of carrier gas to decrease the total analysis time by automatically increasing the carrier pressure during the final back flush. An additional TCD detector may be added to assist in the setting of proper valve switching times. Data handing was accomplished by Agilent chromatography software.

Materials and Reagents

Samples are injected into the GC and vaporized in the 1079 split injector. The CP-TCEP for Alcohols in Gasoline column pre-separates the low-boiling and non-polar components from the higher boiling and polar components. The lower boiling and non-polars (those eluting before methylcyclopentane) are flushed to vent (Figure 1).

At a pre-determined time, the capillary column is switched in-flow and the polar components (including all the alcohols and ethers) and higher boiling compounds are back flushed from the CP-TCEP for Alcohols in Gasoline column onto the non-polar column where they are separated according to their boiling points (Figure 2). After the complete elution of benzene and TAME, the capillary column is back flushed to the detector. This composite peak is not quantified but shows when the back flush has been completed by a return of the signal to baseline.

Electronic Flow Control (EFC) can be

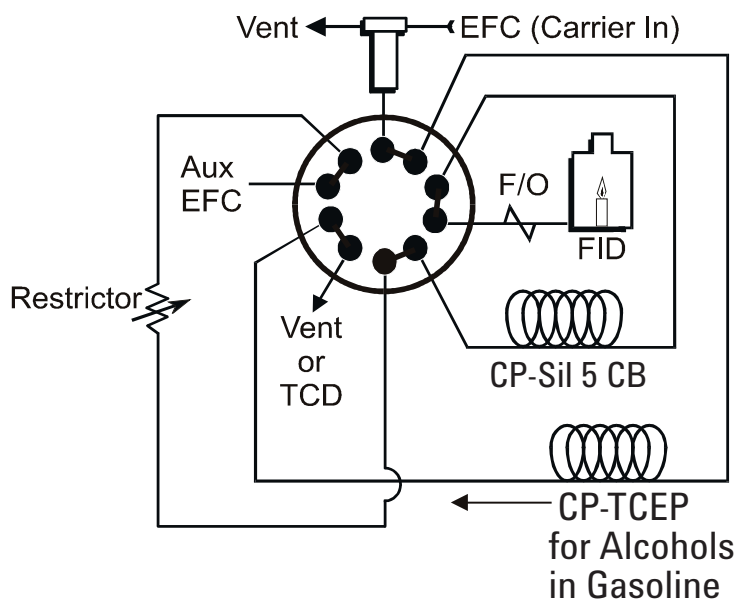

Figure 1. System setup for low boiling and non-polar components

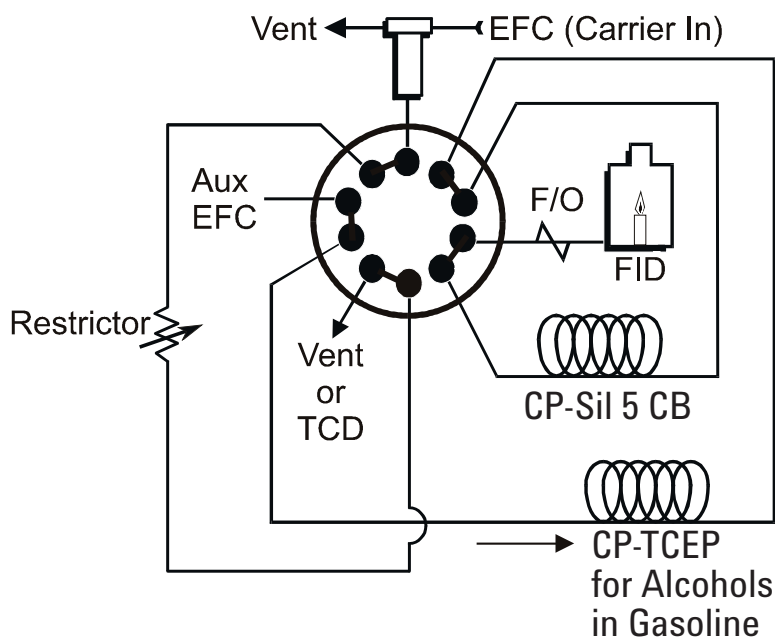

Figure 2. System setup for higher boiling and polar components

used to increase the column pressure at this time. This will speed the return of the signal to baseline and, thereby, decrease the overall analysis time by approximately 40%.

Calibration is made with several multi-component mixtures each

containing different amounts of each of the oxygenated compounds. An amount of an internal standard such as 1,2-dimethoxyethane (DME) is added to each level. The system then automatically generates a calibration curve for each analyte and computes linearity data.

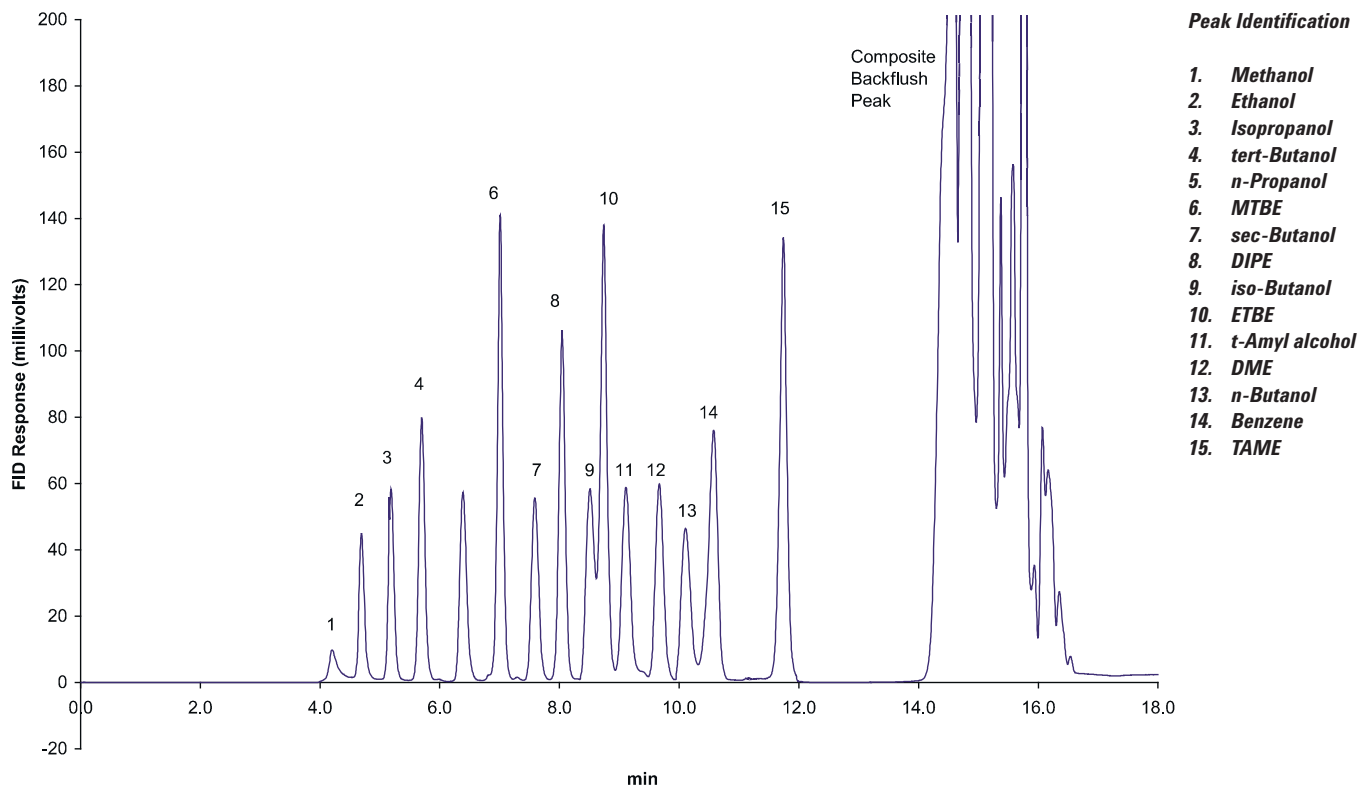

Figure 3. Chromatogram of Scott Gases qualitative oxygenates blend (a mixture of approximately 1% by weight of each alcohol and 3% by weight of each ether, including the internal standard DME)

Results and Discussion

Results were generated automatically and can be printed at the end of each run. Figure 3 shows the chromatogram of a Scott Gases qualitative oxygenates blend.

Conclusions

The GC configured for oxygenates in gasoline offers the petroleum chemist a reliable, fully automated device for ensuring compliance with current CARB and EPA requirements for reformulated gasoline. The instrument conforms fully to the ASTM D 4815 procedure and provides excellent separation and quantitation for all the specified oxygenates.

Reference

ASTM D 4815. Standard Test Method for the Determination of MTBE, ETBE, TAME, DIPE, tertiary-Amyl Alcohol, and C1 to C4 Alcohols in Gasoline by Gas Chromatography. American Society for Testing and Materials, Philadelphia, PA, USA.

www.agilent.com/chem

This information is subject to change without notice.

© Agilent Technologies, Inc. 2012

Published in USA, September 17, 2012

SI-02319



Agilent Technologies