

DP10E / DP12E

The vacuum filler with rotary vane pump for industrial-scale plants



Top performance with no compromises.

The DP10E / DP12E redefines the standard for vacuum fillers with rotary vane pump. The modular system of vacuum filler plus specially-adapted attachments enables tailor-made solutions to be found for every application.

Filling speeds of up to 6 (DP10E) or 7 (DP12E) tonnes an hour – adequate reserves for every requirement of the large-scale plant.



DP10E with DHV841

Ideal hygiene and production reliability

The DP10E / DP12E meets the most stringent standards of quality and hygiene. The one-part hopper with optimised feed unit seals guarantees a reliable seal under all production conditions. The feed screw is dismantled for cleaning in just a few easy steps once the hopper is opened up. The feed unit seals are freely accessible once the feed screw has been dismantled, so they can be checked every time the machine is cleaned and quickly changed if necessary.

All the operator has to do to access the rotor is to release the hinged housing.

Simple maintenance

Removable housing covers on three sides of the machine make the inside easily accessible for all maintenance work. Maintenance work due is shown automatically by the portioning computer.



High-performance drive technology

The high-performance servo drive is low wear and low maintenance and guarantees maximum filling pressures under any conditions.

Convenient operation

The portioning computer is the perfect support for the operator in his daily work. The control panel with integrated digital keypad was designed in line with ergonomic principles. All output is shown in clear text in the desired language. A protective cover protects the portioning computer from splashes.

The machine can also be equipped with a portioning computer with a graphical user interface as an option.

The VEMAG Online net software package can be used to connect the portioning computer to a central computer in the plant and, in a further expansion stage, to connect it to VEMAG Customer Service by modem.

The heart of the machine – the VEMAG rotary vane pump

The product to be filled is handled with extreme care by the rotary vane pump from the feed unit to the machine's outlet. The virtually friction-free pumping of the product to be filled assures extremely high accuracy in the portioning weight.

The user can select from different types of rotary vane pump to adapt the machine to the particular product to be filled.

Changing individual components of the rotary vane pump is straightforward. Cleaning is also very easy. Low wear is a feature of all parts.



www.vemag.de

Technical data

Filling rate:	depending on the feed element up to 6,000 kg/h (DP10E) or 7,000 kg/h (DP12E)
Portion weight:	5 - 60,000 g, can be set in increments of 0.1 g or 1 g
Portioning speed:	> 750 portions/min (depending on product, casing and portion size)
Links:	0 - 10, infinitely adjustable
Vacuum unit:	16 m ³ /h / 40 m ³ /h (optional)
Hopper capacity:	250 l / 350 l (optional)
Weight with lifting and tipping device:	approx. 1,300 kg
Nominal power total:	12 kW (DP10E) or 14 kW (DP12E) at 50/60 Hz

	Hopper with 250 l	Hopper with 350 l
A	2505	2665
B	1935	2040
C	min. 2940	min. 3040
	max. 2995	max. 3090

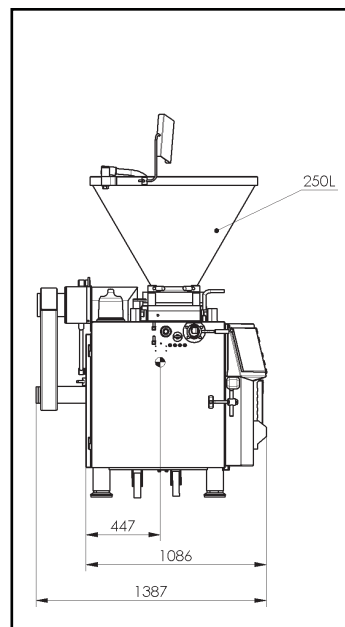
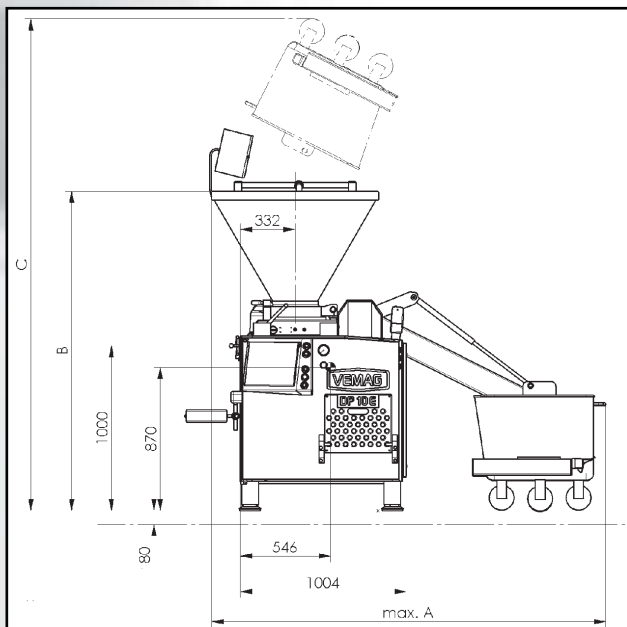

ISO 9001
BUREAU VERITAS
Certification



VEMAG Maschinenbau GmbH
P.O. Box 1620, D-27266 Verden
Phone +49 42 31 - 77 70, Fax +49 42 31 - 77 72 41
<http://www.vemag.de>, e-mail@vemag.de

Presented by: