

# FSL210

## Portioning, linking and separating device for sausages



### Flexible requirements – one machine

FSL210 – Program name: Flexible Sausage Line. A machine that can be universally used in sausage production – flexibly adapting to almost every application. Flexibility is by far the word that best describes the FSL210. It is used in your production, where a wide variety of different products are produced – precisely where a machine is flexibly adapted to the product and not the other way round. The FSL210 implements product ideas.



Flexible Sausage Line FSL210

The FSL210 is a machine offering flexible and accurate length portioning, linking and separating of sausages in natural, collagen and cellulose casings.

### Flexible production

Each sausage is different, and each product is handled differently. Here the FSL210 shows what it can do. The calibre and weight are specified. Data is entered using the intuitively operated control unit on the vacuum filler, or a separate control unit on the FSL210. Stored data can be called up by simply changing the program. And the length? The length is calculated by the machine automatically – and it links the sausage at exactly the right point, without any more programming. Simply flexible and fully automatic, irrespective of how long the sausage must be. You can therefore use the FSL210 right away. And if a different length is preferred, perhaps to produce under filled sausages or to adapt the product to existing packaging, then the setting can be changed manually. Almost anything is possible. The integrated separation unit then separates the sausage at the right point as required. This machine can do it all. And if a product with another calibre is processed or the weight needs to be changed? That's just as easy. Simple set the weight or calibre again, the length is then calculated automatically and the sausage is linked at the right point. And this is at up to 800 portions per minute. The number of links can also

be adjusted. Whether it is fresh grilling sausage, merguez, chorizo or breakfast sausage: the links will be correct. And the optional natural casing recognition will ensure the casing is better utilised, so casing costs fall and profit increases.

### Flexible transport belts

They are responsible for (almost) everything: Transport as well as clamping of sausages while linking. This is what makes the FSL210 so flexible – every length can be produced.

Three belt pairs guarantee the perfect sequence. After the linking belt, a second belt pair takes the sausages to stretch the linking point, fixes the optimal cutting point and ensures more accurate cuts – ensuring a clean cutting result for all types of casings.

### Flexible blade usage

An option rather than a necessity. Irrespective of whether the FSL210 outputs a sausage chain or individual sausages on a filling table, the precision blade separates the sausages from one another as required. Whether it is individual sausages, pairs or larger chains that are being separated, the process is fully automatic, quick and precise. This creates even more flexibility for even more fields of application.

The blade box is easy to access, plus simple cleaning and quick blade

changes help to increase productivity. The cutting technology used is tried and tested.

### Flexible casing length

The machine's sensors monitor the filling process. The integrated intelligence of the FSL210 independently recognises the end of the casing (optional). Instances of starting the vacuum filler too early or delaying shutdown with a final portion that goes to waste are now a thing of the past. The machine delivers clean, high-speed operation – just as it should be.

### All the benefits at a glance:

- Flexible use
- Integrated separation module
- High portioning rate
- Natural, collagen and cellulose casing processing possible
- Flexible and precise length portioning with calibre and weight specification
- Natural casing recognition
- 2-minute changeover time
- Easy cleaning possible
- Variable adjustable sausage lengths
- Start/stop sensor (optional)



## Technical data

Portioning rate:	Cocktails: 800 port./min
Portion lengths:	Depending on casing, calibre and weight From 55 mm – no limit, single cut From 40 mm – no limit, for 2 or more sausages
Calibre:	13 – 40+
Casing types:	Natural, collagen and cellulose casing
Casing lengths:	Up to 430 mm (collagen casing)

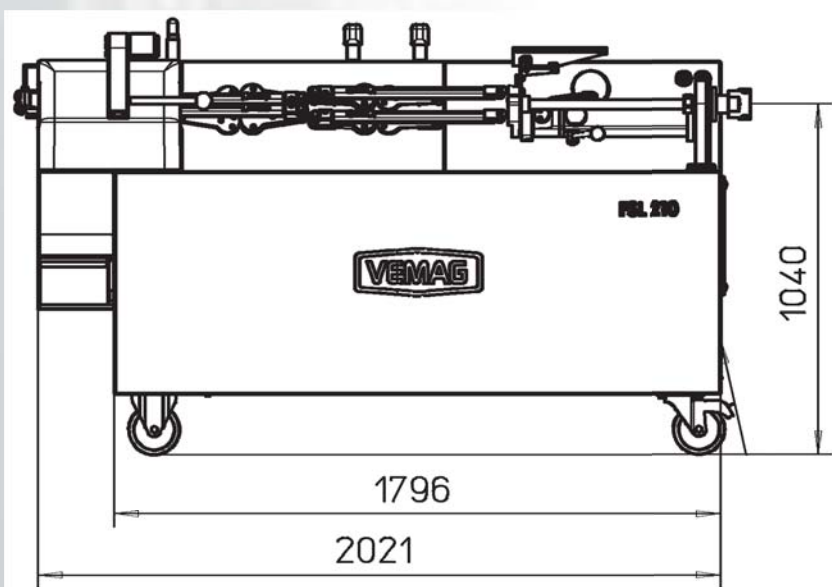
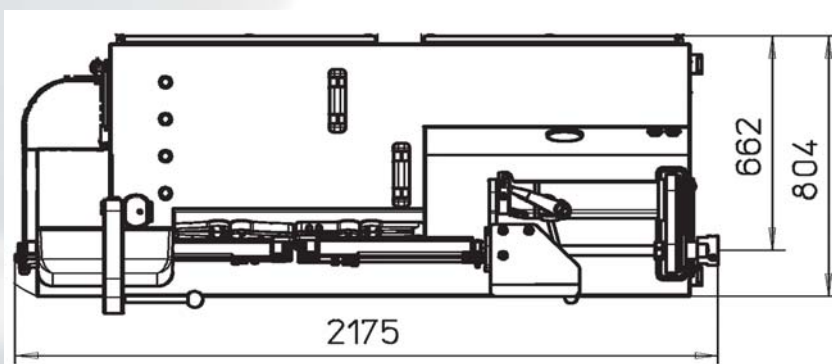

ISO 9001  
BUREAU VERITAS  
Certification



VEMAG Maschinenbau GmbH  
P.O. Box 1620, D-27266 Verden  
Phone +49 42 31 - 77 70, Fax +49 42 31 - 77 72 41  
<http://www.vemag.de>, e-mail [vemag.de](mailto:vemag.de)

Presented by: