



## Seydelmann Cutter K 754

The Seydelmann Vacuum-/Cooking-Cutter K 754 offers maximum ease of operation developed according to ergonomical requirements including an extensive equipment. The components of all Seydelmann Machines comply with the up-to-date technical development and contribute to an increase in product quality.

### Facts

Bowl content: 750 liters  
 Weight: 7000 kg / 15432.1 lbs  
 Loading options: 120-, 200- or 300-l trolley

Power of motor:

rasant, ultra:	140 kW / 187.74 HP
rasant v, ultra v:	160 kW / 214.56 HP
rasant vs, ultra vs:	190 kW / 254.80 HP
AC-8:	250 kW / 335.26 HP

### Applications

Suitable in particular for the emulsification, mixing and chopping of fresh meat, precut frozen meat, cooked meat as well as fish, vegetables, fruits and other edibles at temperatures from -18 (-1 °F) up to 85 °C (185 °F).

### Machine Design

The machine frame of the K 754 is made of stainless steel. All edges are rounded and all surfaces are polished very precisely and designed with a slope enabling cleaning water to drain completely from all surfaces. The embedded covers and the closed bottom with ventilation prevent pollution and water from entering the machine. The knife hood is flow dynamically shaped. Hardly any chopped product residue is left in the cover. The gap between the knives and the cover or the bowl is very small.

### Vacuum-Function

Cutting under vacuum, a firm emulsion free of air with a volume reduction of 5-7% is produced. Therefore, an even better fineness of the product is achieved. Thanks to the exclusion of air, the final product gains a significantly longer shelf life. A better protein extraction increases the moisture and fat absorption of the product improving the development of the flavour of spices next to the better binding and stability of the final product.

### Cooking-Function

The bowl is heated up by hot steam from a nozzle system installed below the bowl. Enormous time savings can be achieved thanks to cooking and cutting in one step. The production time can be further reduced using an additional heating for the knife hood. An increase of approx. 10% in the volume of the material as well as the complete preservation of taste, aroma and protein is possible. Cooling is optionally available via a nozzle system.



## Maschinenfabrik Seydelmann KG

info@seydelmann.com    Tel. +49 711 / 49 00 90-0  
 www.seydelmann.com    Fax +49 711 / 49 00 90-90

Hoelderlinstrasse 9 | 70174 Stuttgart | Germany

**Cutters**  
**Mixers**  
**Grinders**  
**Emulsifiers**  
**Production Lines**

Measurements

- H1 = 930 mm / 36.61 in
- H2 = 3260 mm / 128.35 in
- H3 = 3460 mm / 136.22 in
- T1 = 2380 mm / 93.70 in
- T2 = 3000 mm / 118.11 in
- B1 = 2860 mm / 112.60 in
- B4 = 3880 mm / 152.76 in
- X = 2230 mm / 87.80 in

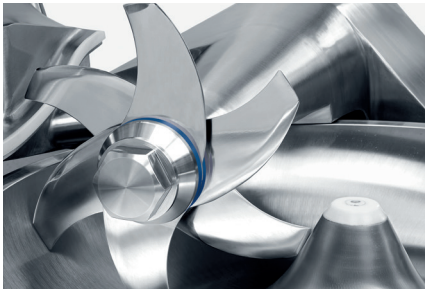
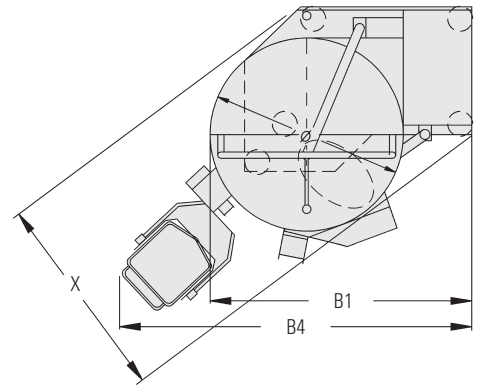
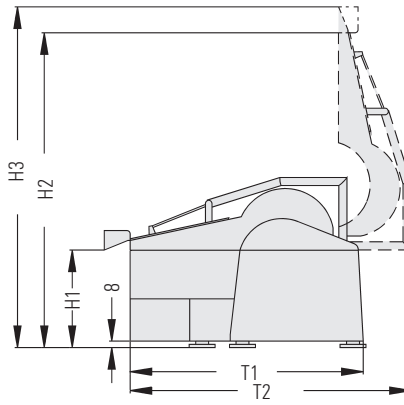

Knife head



Temperature sensor



Fast clamping nut for knives (optional)

Standard equipment

- Vacuum- and/or Cooking-Function
- Operation via cross switches
- Changeable and balanceable knife head
- Hydraulic main cover, noise absorbing cover and ejector
- Vacuum- and noise absorbing cover made of stainless steel
- Separate electrical cabinet made of stainless steel with integrated main switch
- Pneumatic locking of knife shaft arm (K 204- K 1004)
- Vacuum pump (Water ring pump)
- Switch-off for temperature and operating time
- PT 100 temperature sensor
- With AC-8 motor:  
High speed 160 meters per second, central lubrication system, control of unbalanced state

Additional equipment

- Hydraulic loading device
- High speed
- Control of unbalanced state
- Central lubrication system
- Automatic knife shaft balancing system (starting from K 324)
- Frequency controlled stepless bowl
- Water injection nozzle (optionally with water meter)
- Liquid injection nozzle
- Various knife systems
- Fast clamping nut for knives
- Direct steam
- Liquid nitrogen connection
- Cooling via liquid nitrogen (LN<sub>2</sub>) or carbon dioxide (CO<sub>2</sub>)
- Cover heating /-cooling
- Noise insulation version
- Up to 9 switch-offs for temperature and operating time
- Stepless ejector with pre-programmable speeds

Control: Command 1500

- Digital display for gear, knife speed, running time, temperature, bowl speed, time
- Display of water quantities & vacuum values
- Switch-off automatic system for temperature and running time
- Service and maintenance indication
- Stainless steel box

On request: Auto-Command 2000, 3000, 4000

- Data recording
- Service module
- Recipe calculator
- Production plan
- User friendly and logical design
- User administration
- Remote control
- Indication of all technical parameters
- Teach-in function
- Stainless steel box



Auto-Command 4000

Motor types

AC-8

- 6 steplessly programmable knife speeds, forward
- 2 reverse mixing speeds
- 2 separate bowl speeds
- Frequency-controlled 3-phase motor

Ultra

- 2 knife speeds
- 2 forward mixing speeds
- On request: 2 reverse mixing speeds
- 2 separate bowl speeds
- All drive systems with 3-phase motors

Rasant

- 2 knife speeds
- 2 bowl speeds
- All drive systems with 3-phase motors

Maschinenfabrik Seydelmann KG

info@seydelmann.com    Tel. +49 711 / 49 00 90-0  
 www.seydelmann.com    Fax +49 711 / 49 00 90-90

Hoelderlinstrasse 9 | 70174 Stuttgart | Germany

**Cutters  
 Mixers  
 Grinders  
 Emulsifiers  
 Production Lines**