

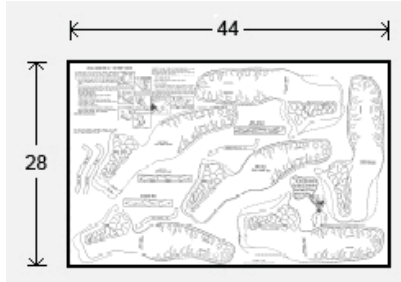

Pattern Digital Download

This PDF file contains 1 (one) full pattern package. The PDF has been put together to give you options when it comes to printing. Pages and patterns that are larger than 8½x11 have been provided in two formats:



1) Full Size

If you would like to have a full size print out, take the full size pages to your local print shop and they can print it for you.

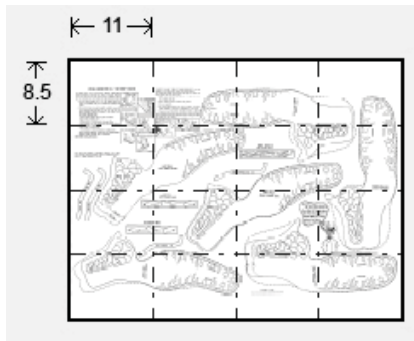

2) Tiled

The tiled pages give you the option of printing the larger patterns at home. You print the tiled pages and then assemble them to make the larger patterns.

The pattern PDF files are typically laid out like this:

Cover(if applicable), instructions sheets (if applicable), pattern 1 – full sized, pattern 1 – tiled, pattern 2 – full sized, pattern 2 – tiled, pattern 3 – full sized, pattern 3 – tiledetc

Please note: When printing on a home printer, use the settings seen on the image to the right in the Page Handling area of the Adobe Reader print dialogue box. If your printer is cutting edges off, set “Page Scaling” to “Shrink to Printable Area”. This will, however, decrease the size of the pattern a very small amount.

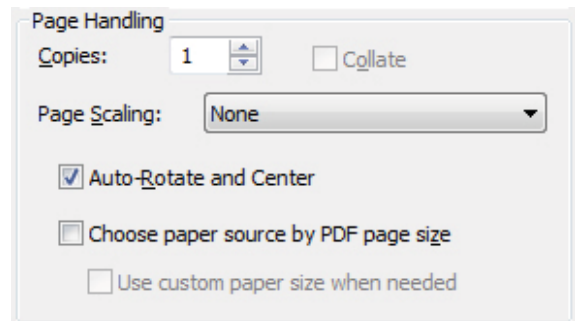

You may take this PDF file to your local print shop to have the full-size pages printed for your own personal use.

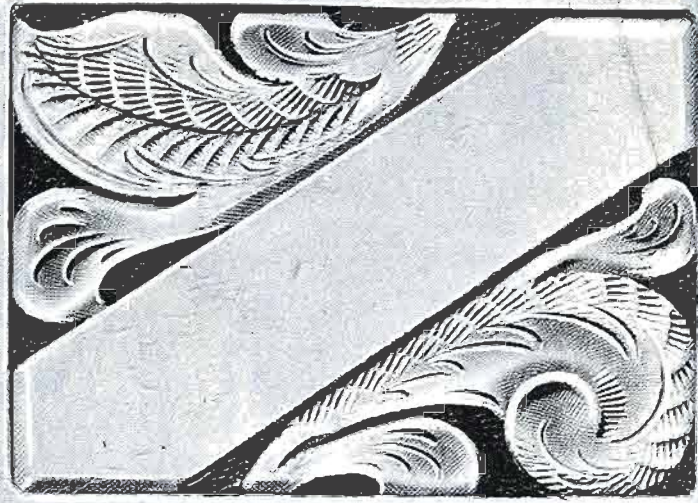
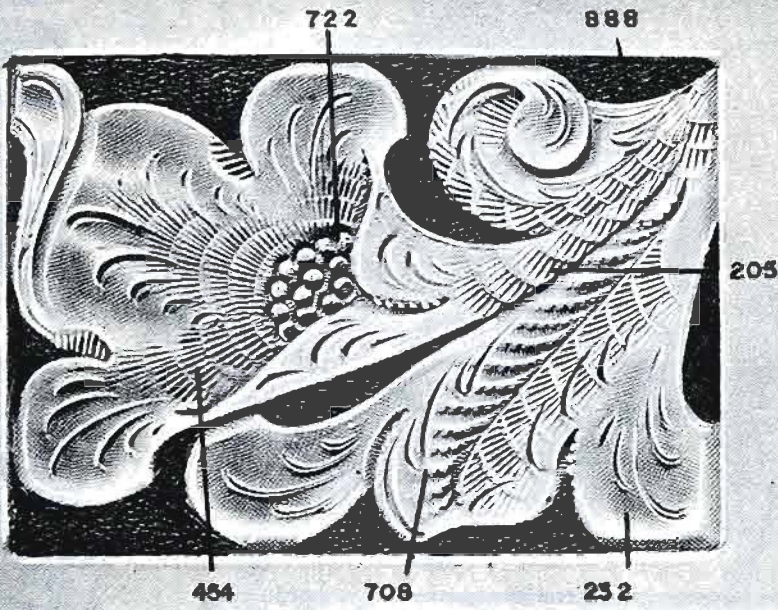

NEW Tandycraft!

PATTERN SHEET

1921

- patterns for belts and billfolds
- alphabets
- helpful instructions

**NO.
54**

© Copyright 2010 by Tandy Leather Factory
 DISTRIBUTED BY TANDY WAREHOUSE CO., FORT WORTH, TEXAS All Rights Reserved
 DIVISION OF TANDY CORPORATION

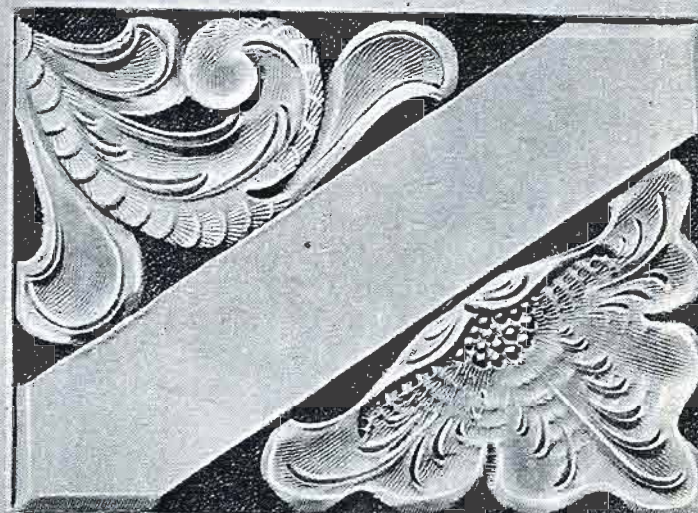
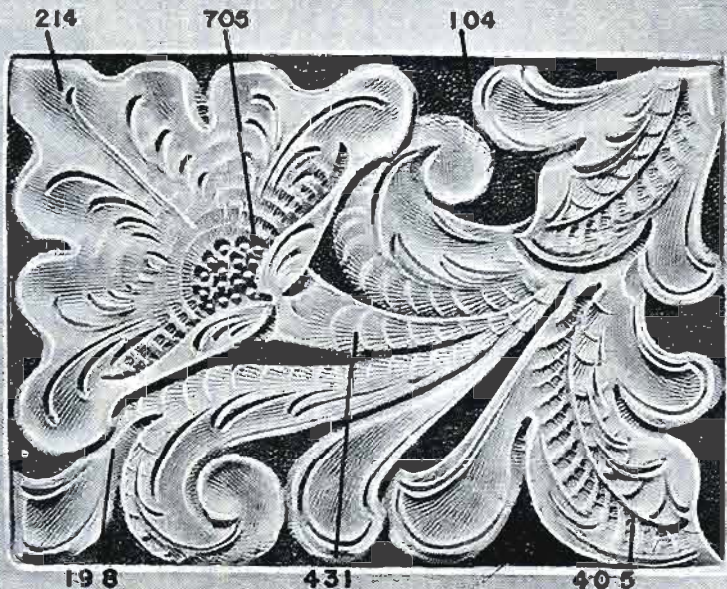

USE DOTTED LINES FOR ENDS OF TROPHY BELTS

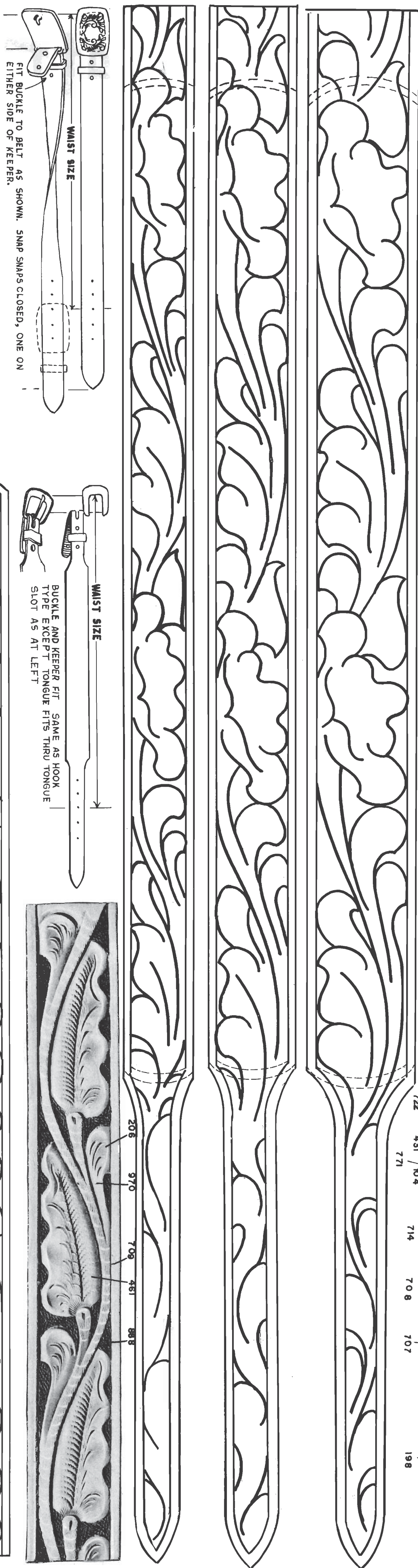

DOTTED LINES ON PATTERNS ARE FOR TROPHY BELT ENDS

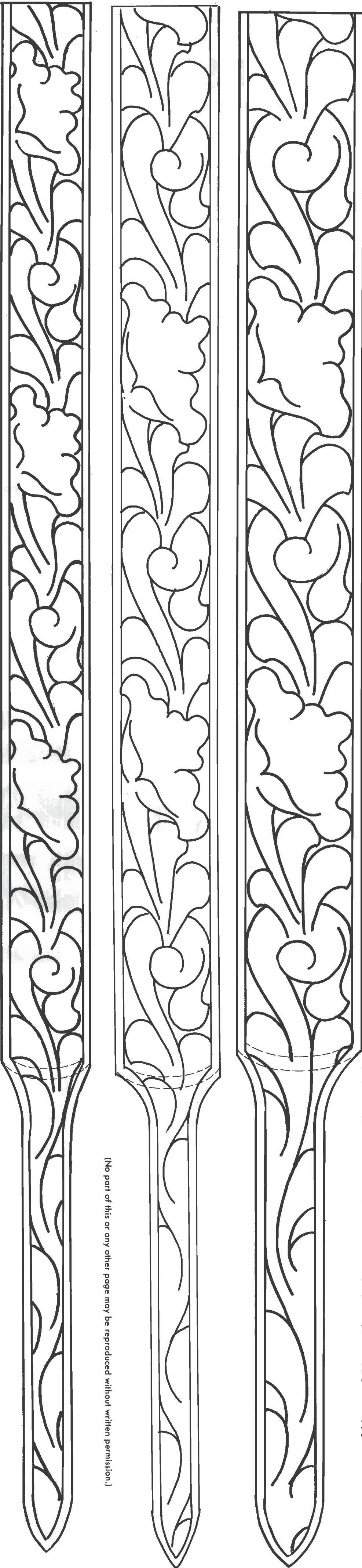
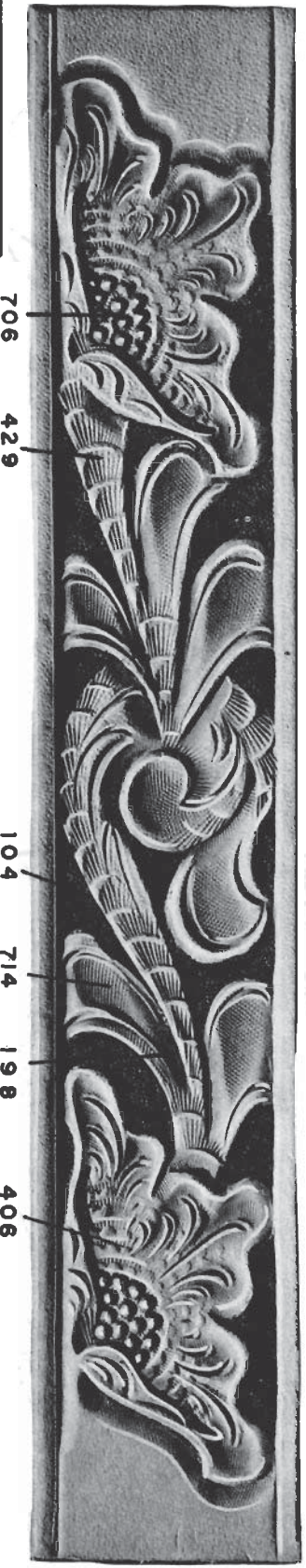
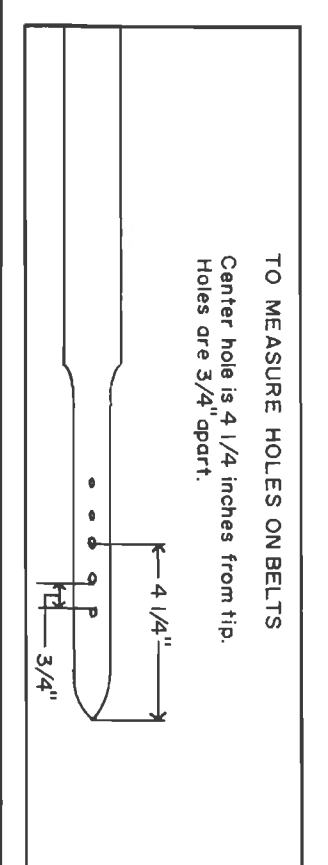

NEW! Tandy Handycraft!

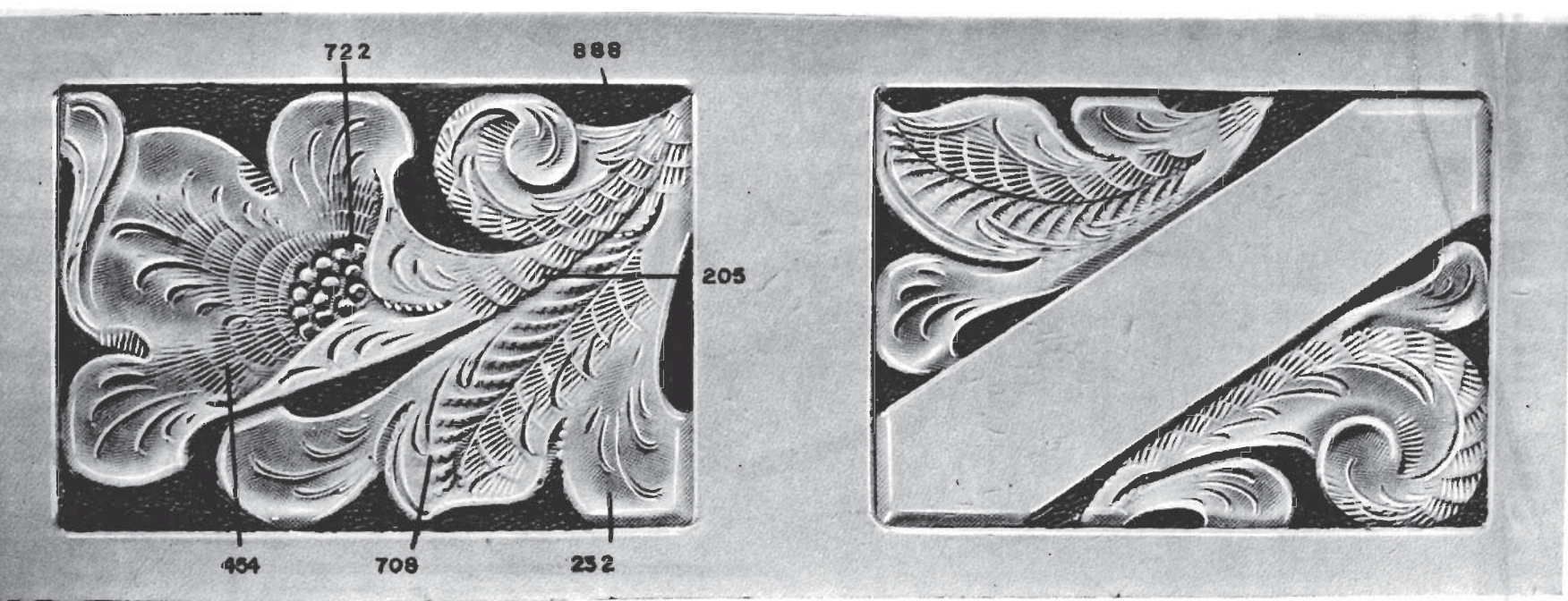
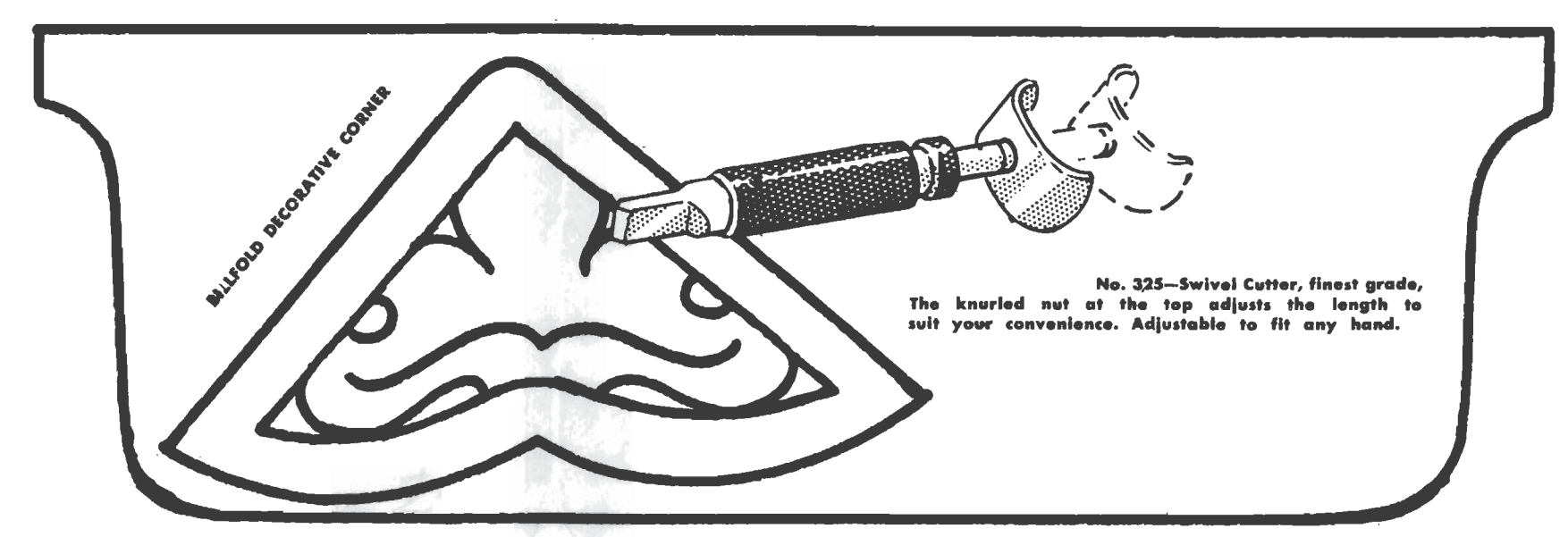
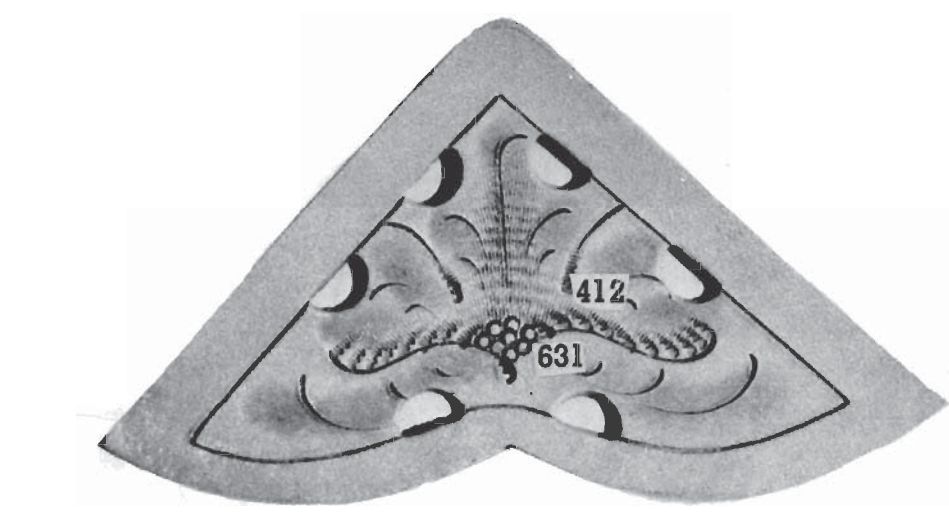
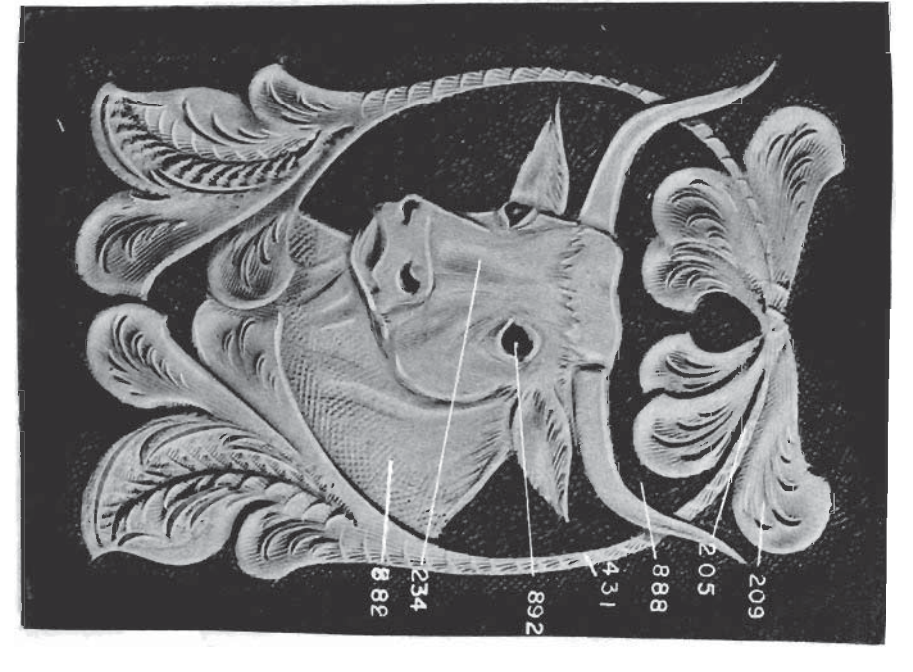

HOW TO LACE WESTERN DOUBLE LOOP

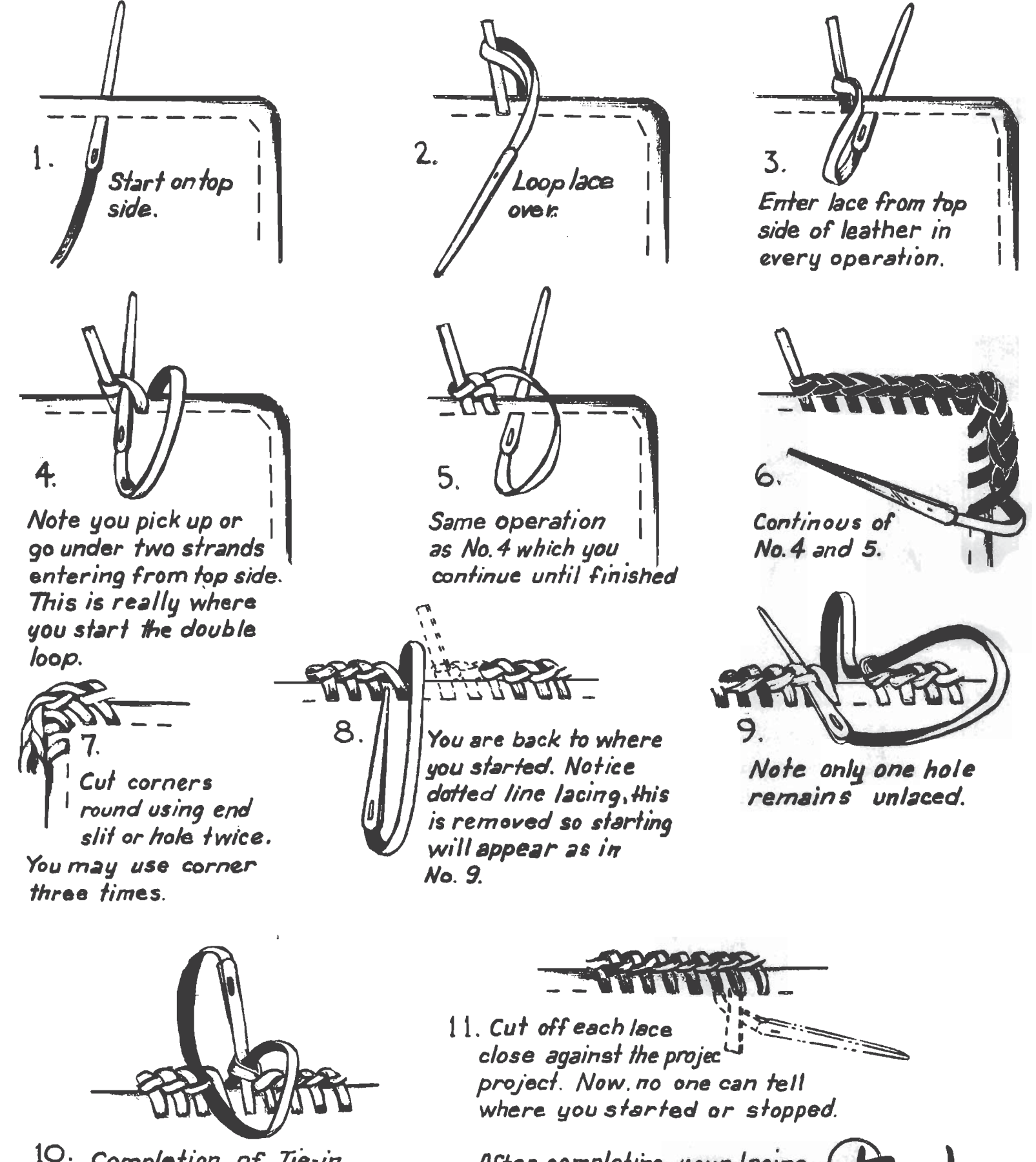

NEW Tandy Handycraft!
PATTERN SHEET NO. 54
 1921
 • patterns for belts and billfolds
 • alphabets
 • helpful instructions
 DISTRIBUTED BY TANDY WAREHOUSE CO., FORT WORTH, TEXAS
 DIVISION OF TANDY CORPORATION

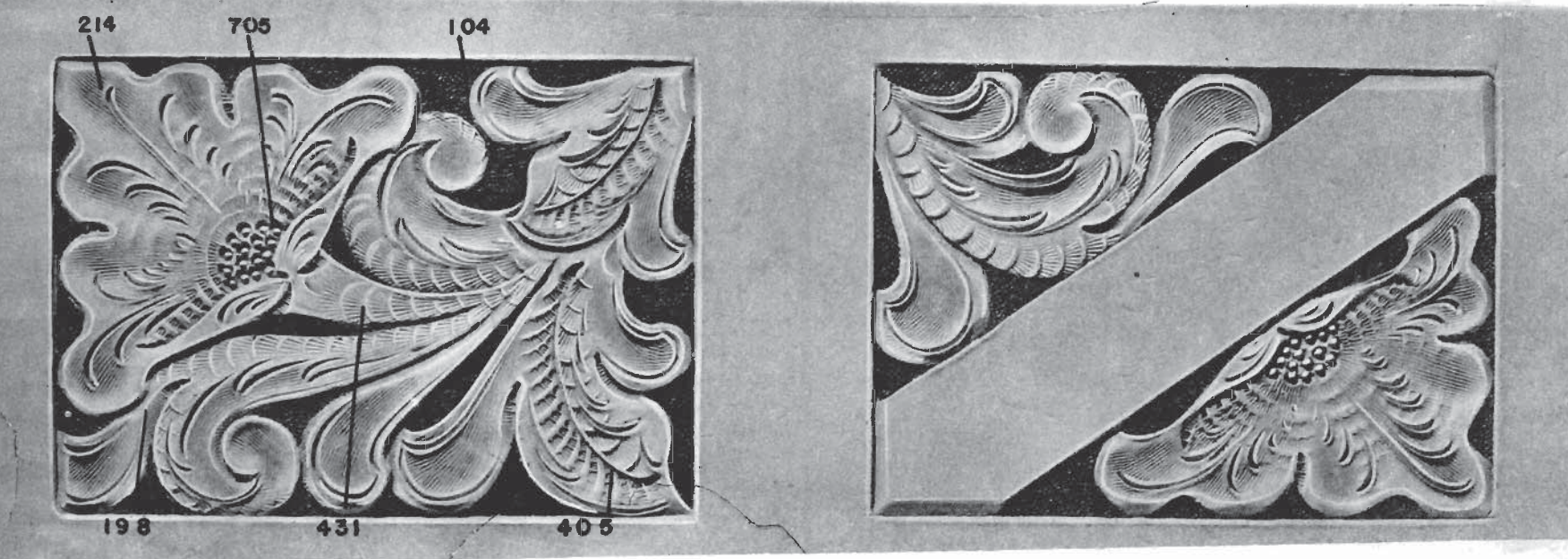

NO. 54 BELT PATTERNS

Tandy Handycraft



SEE PAGE 4 FOR

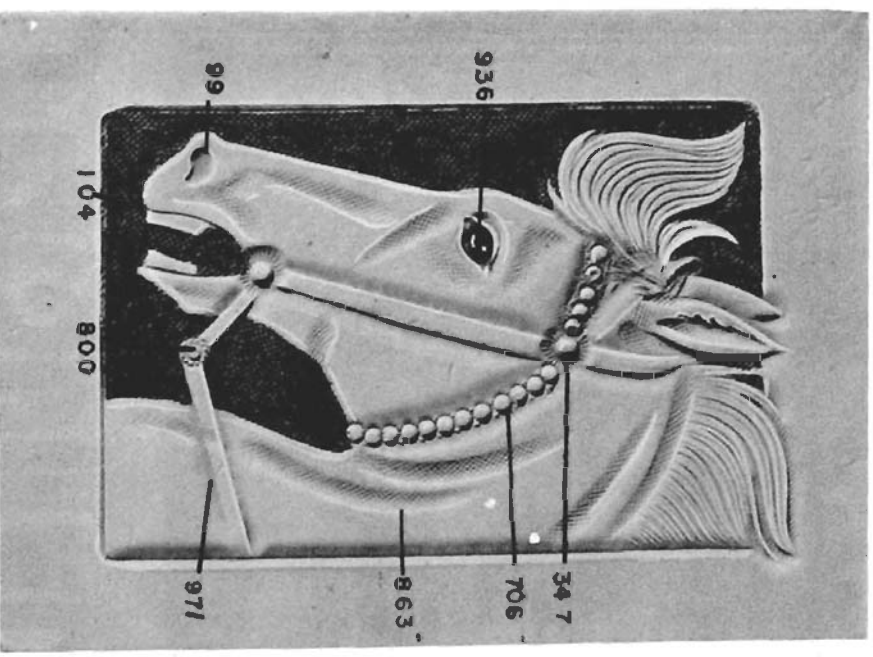

972
Newt-

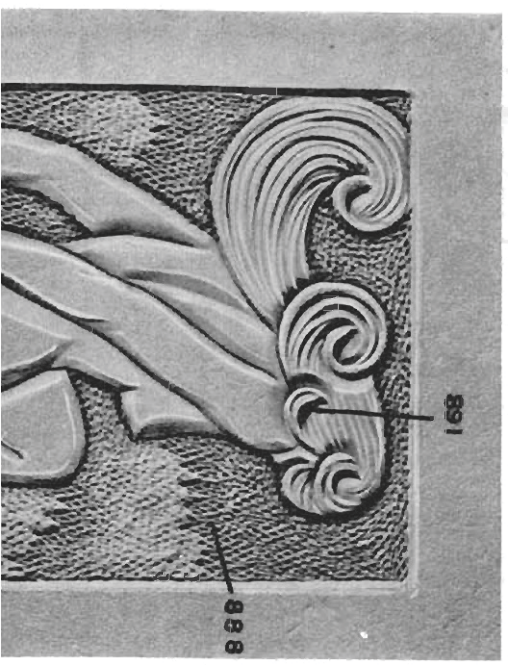
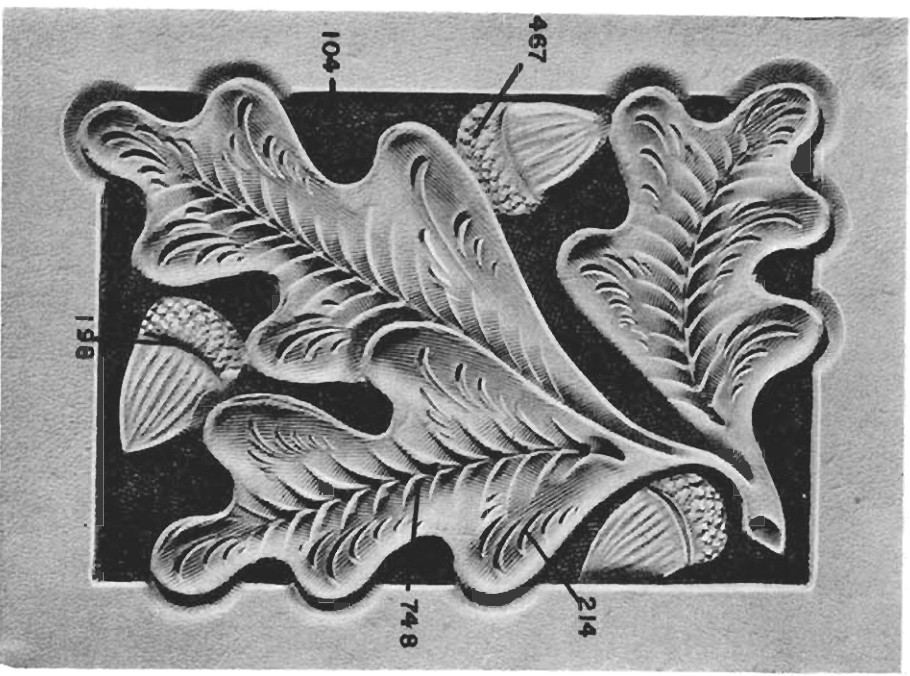

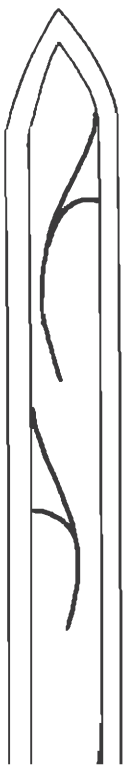
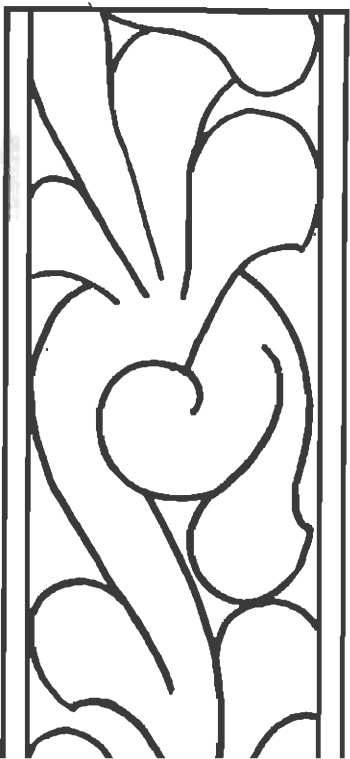
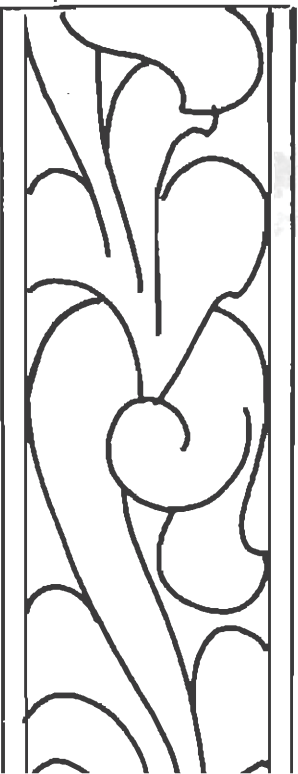
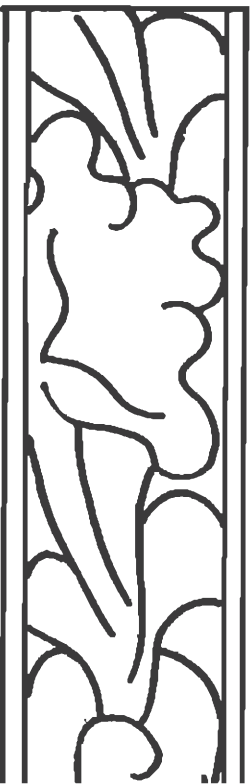

USE DOTTED LI

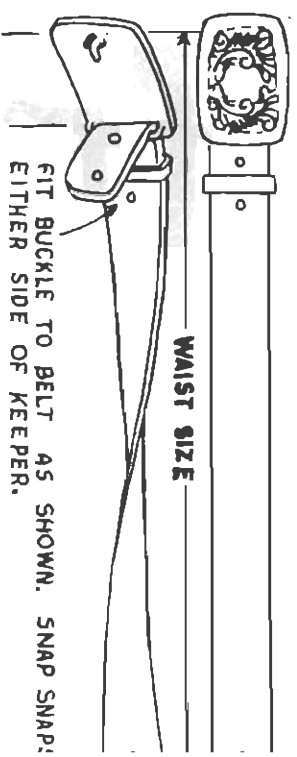
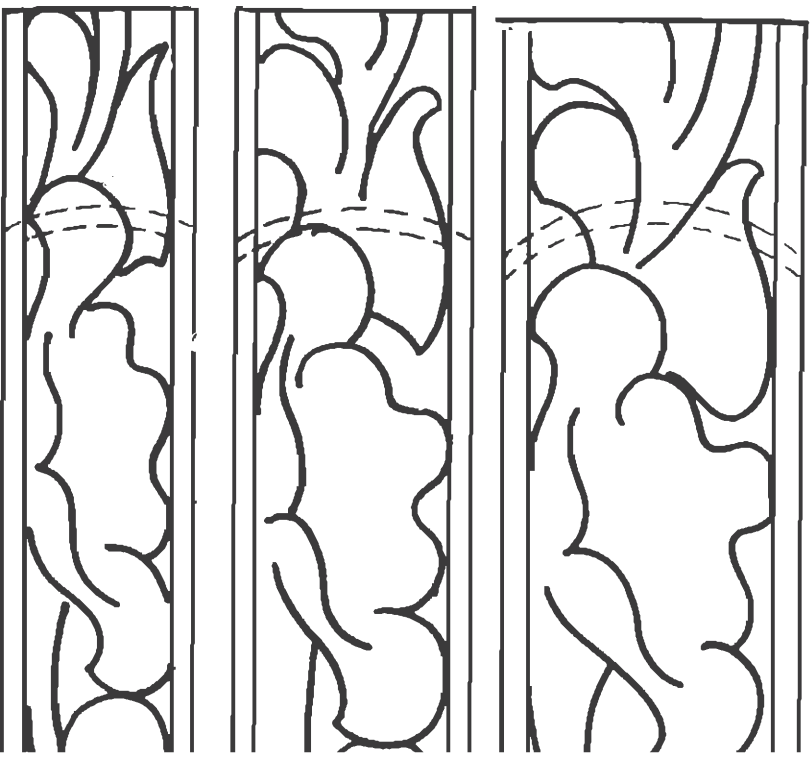

FIT BUCKLE TO BELT AS SHOWN. SNAP SNAPS EITHER SIDE OF KEEPER.



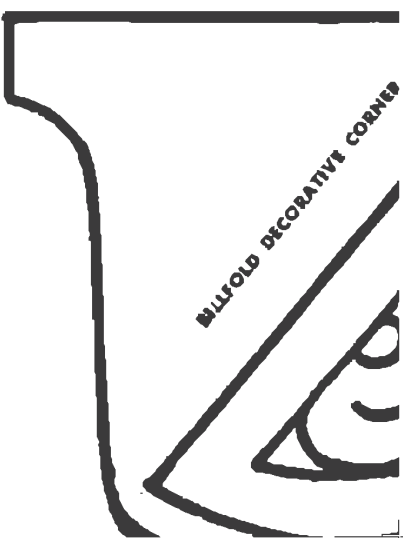

TRACING PATTERNS

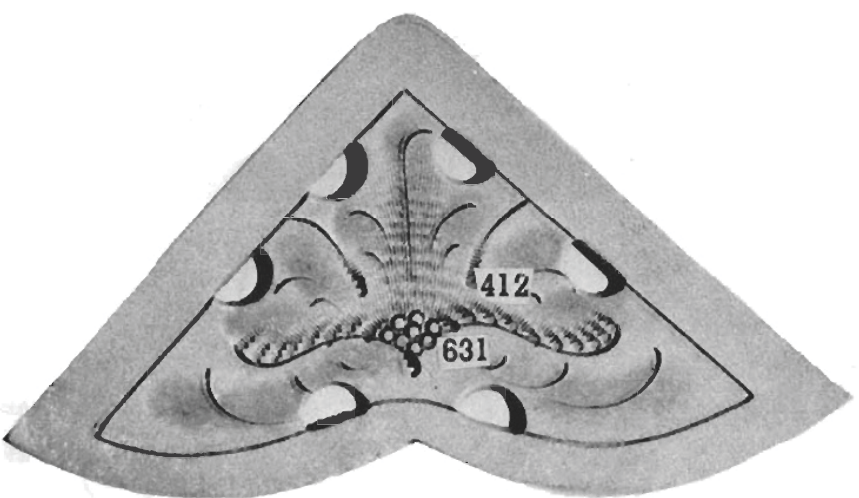
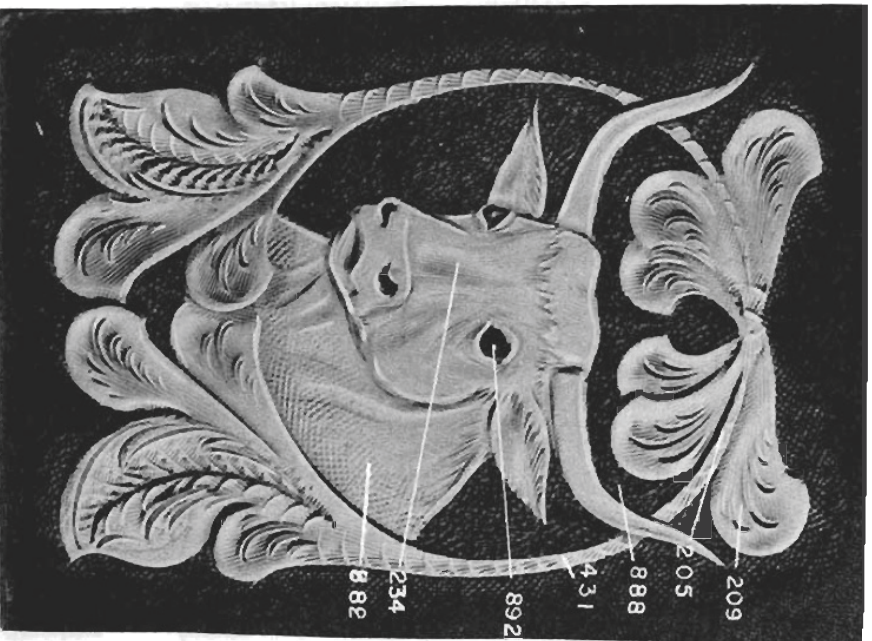

Handycraft!

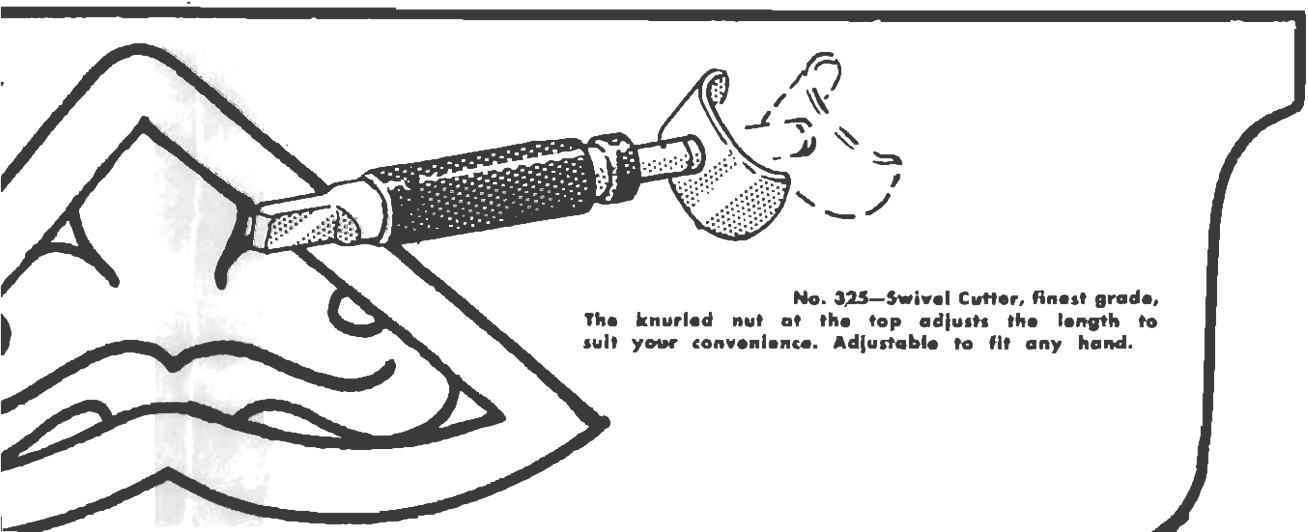
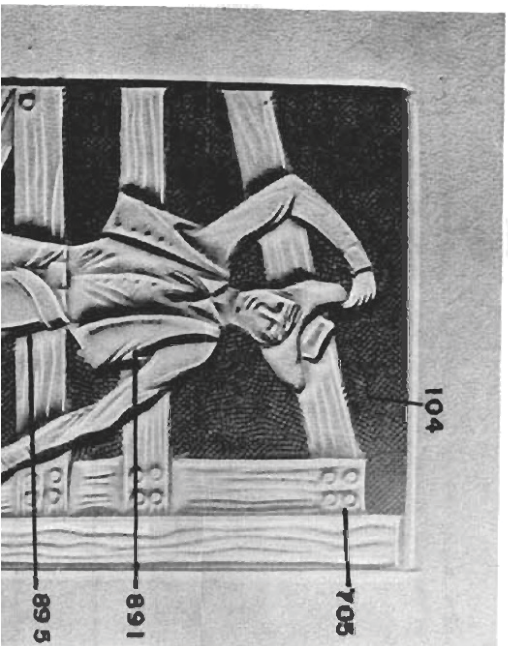
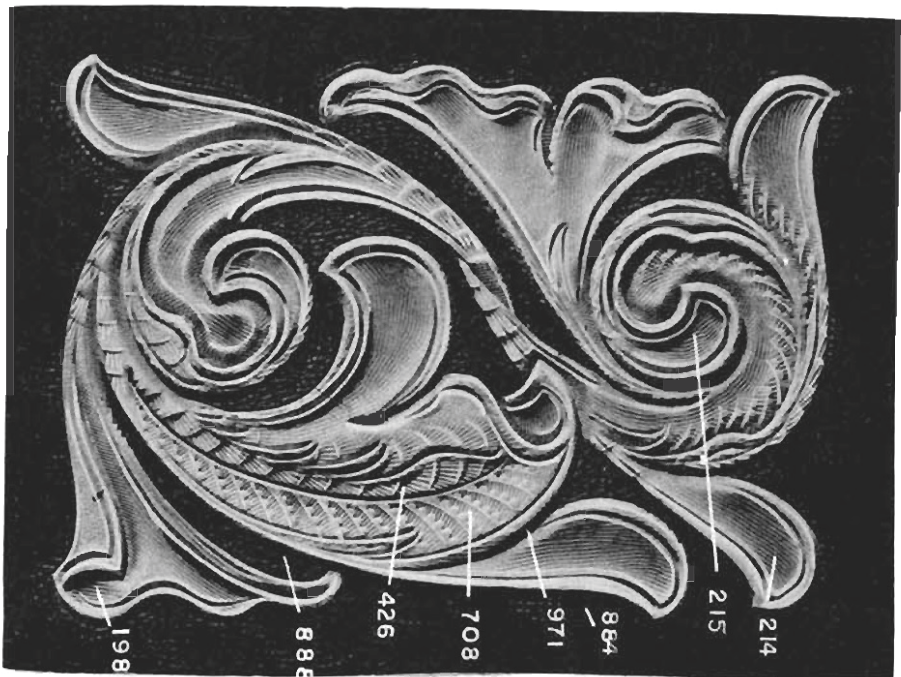

No. 325—Swivel Cutter, finest grade,
The knurled nut at the top adjusts the length to
suit your convenience. Adjustable to fit any hand.

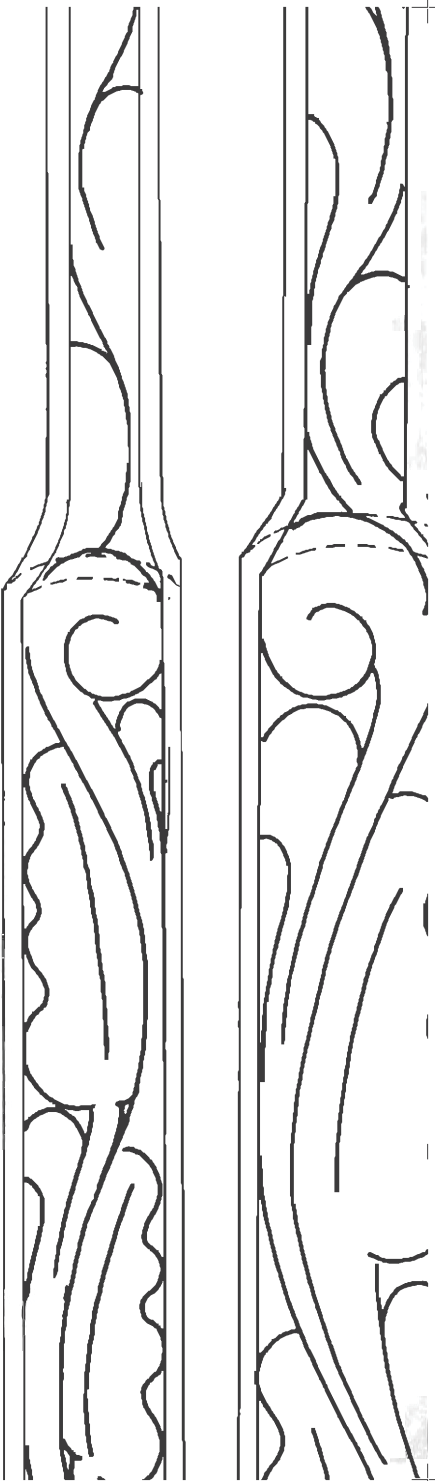

S ARE FOR TROPHY BELT ENDS

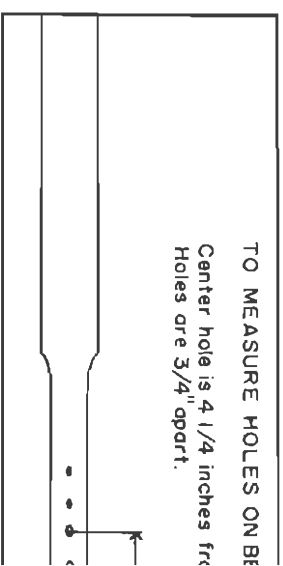

BELTS FOR ENDS OF TROPHY BEL

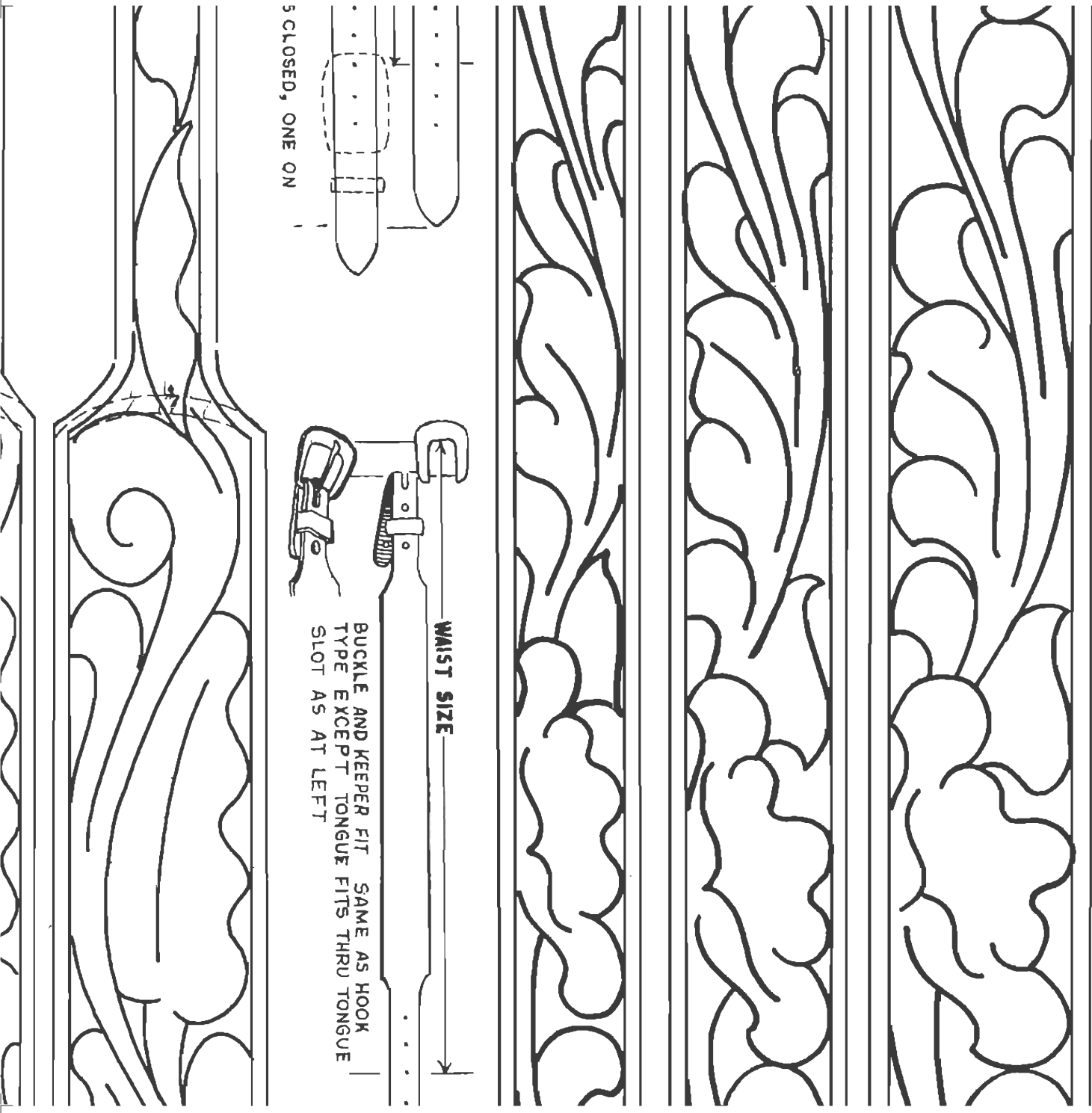

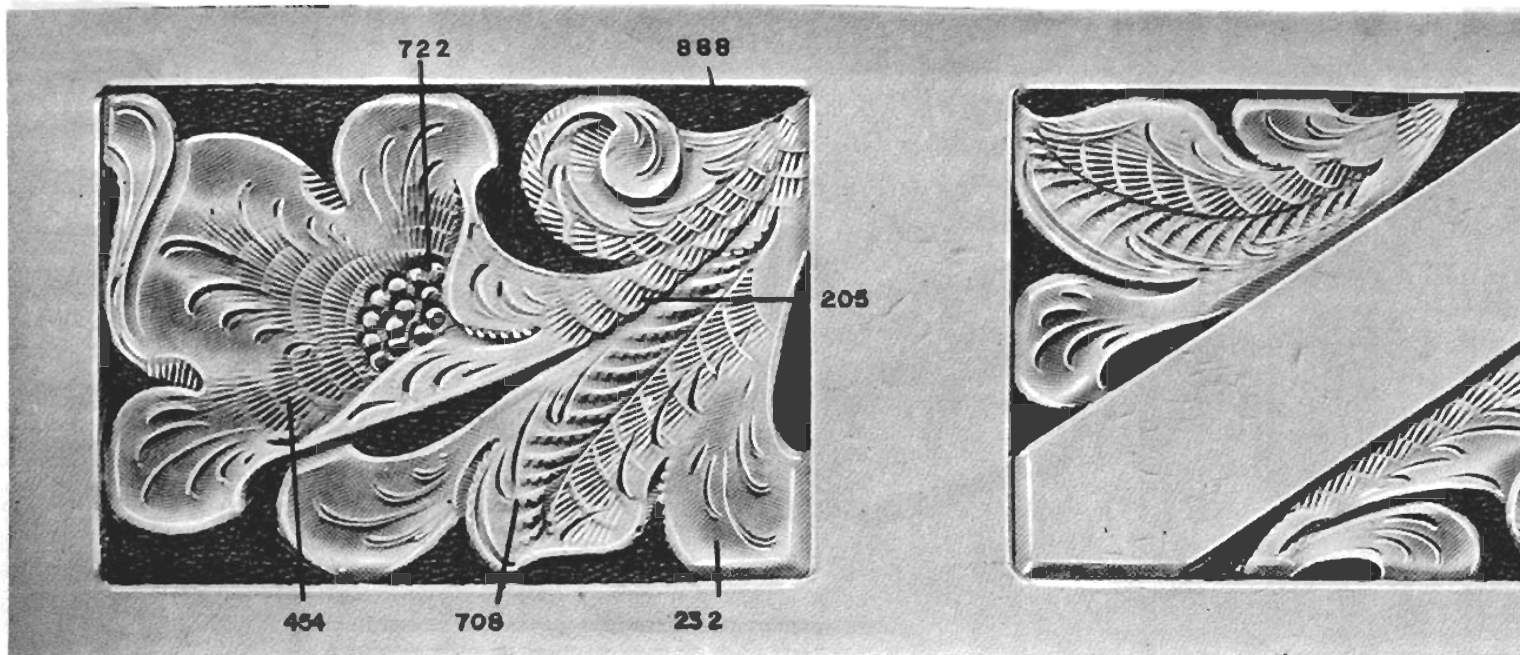

NEW Tandycraft

PATTERN SHEET

1921

- patterns for belts and billfolds



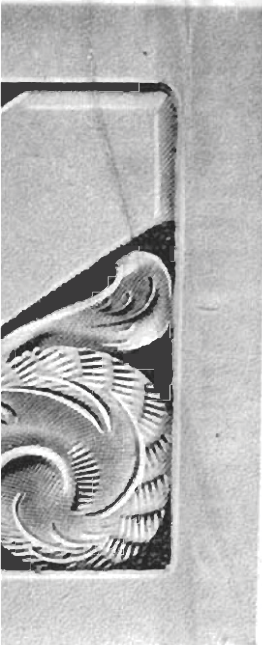

HOW TO LACE WESTERN DOUBLE LOOP

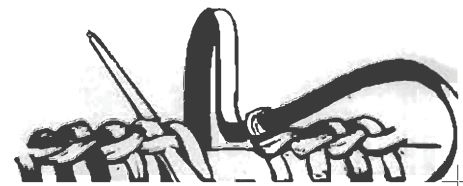
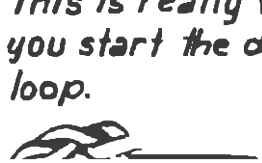
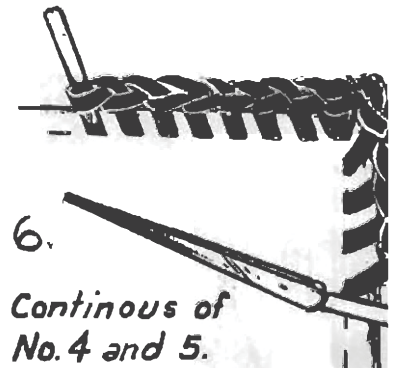
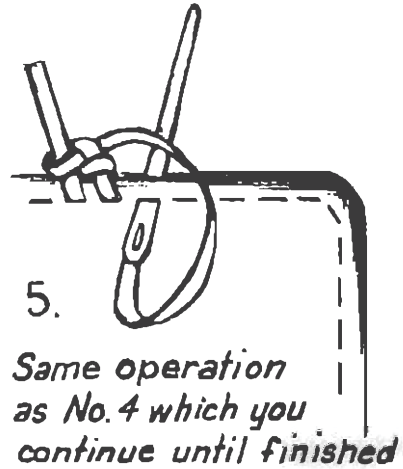
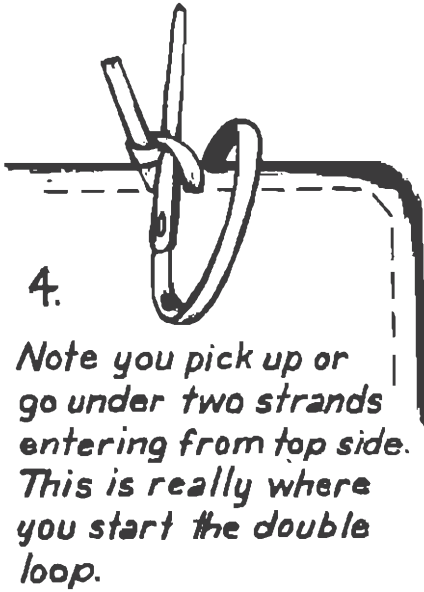
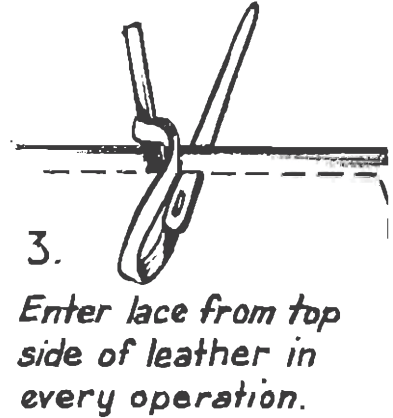
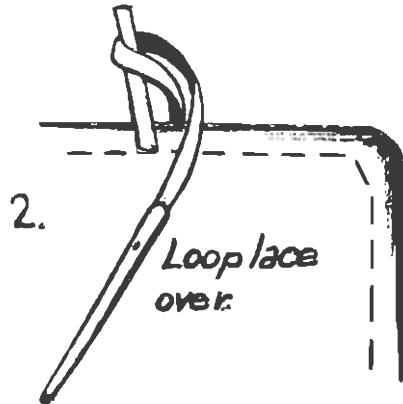
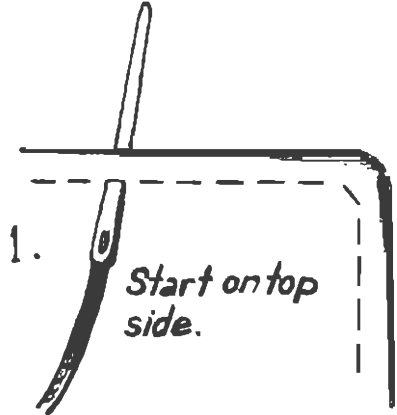

5!
0.
4

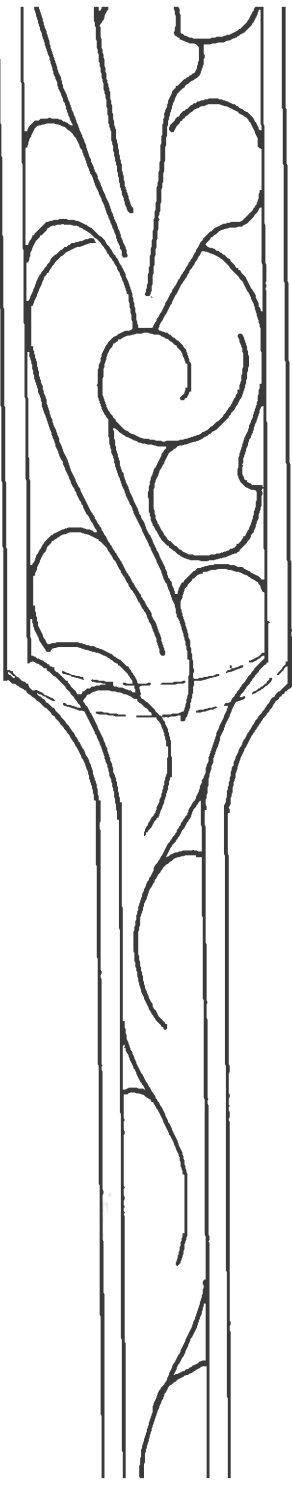
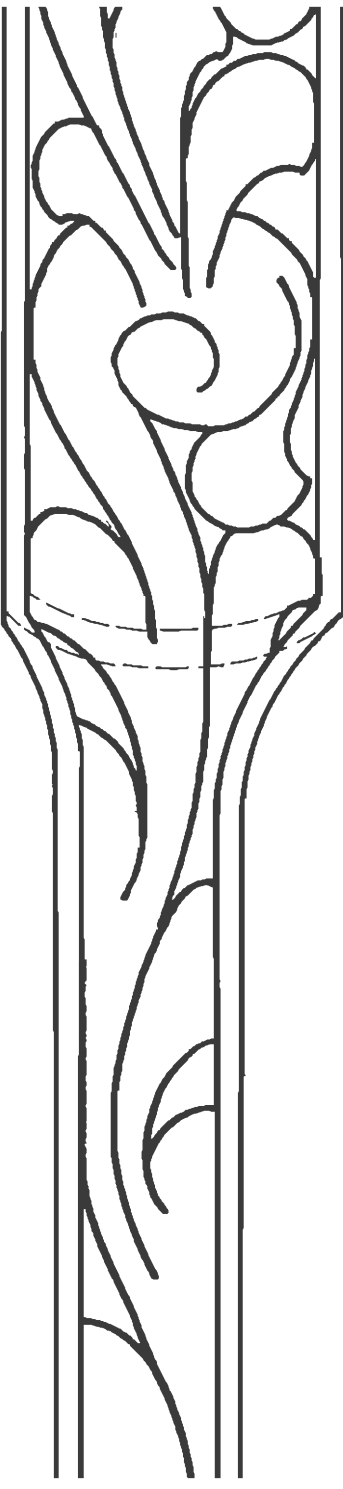
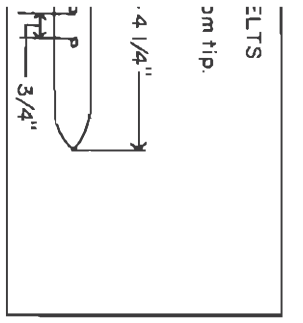
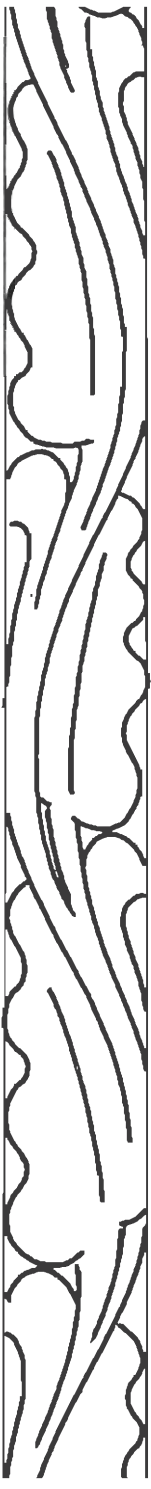
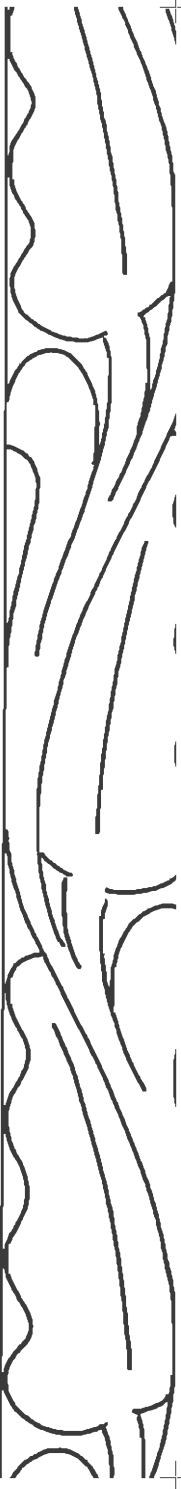

(No part of this or any other page may be reproduce

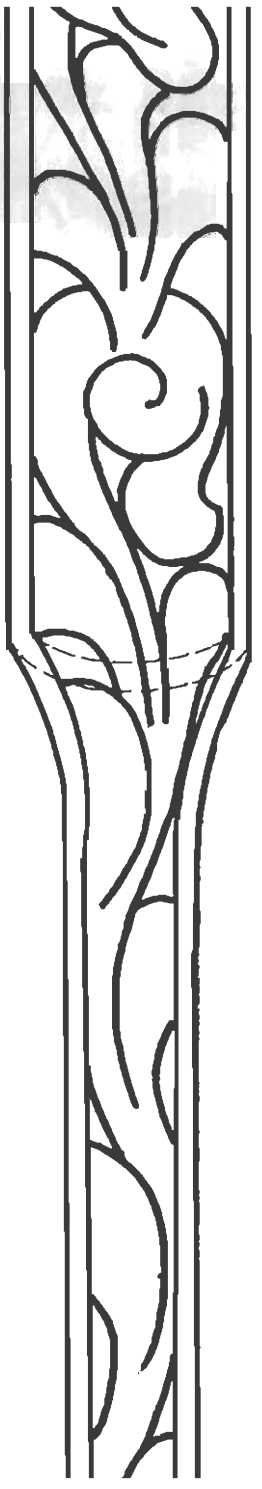

TS

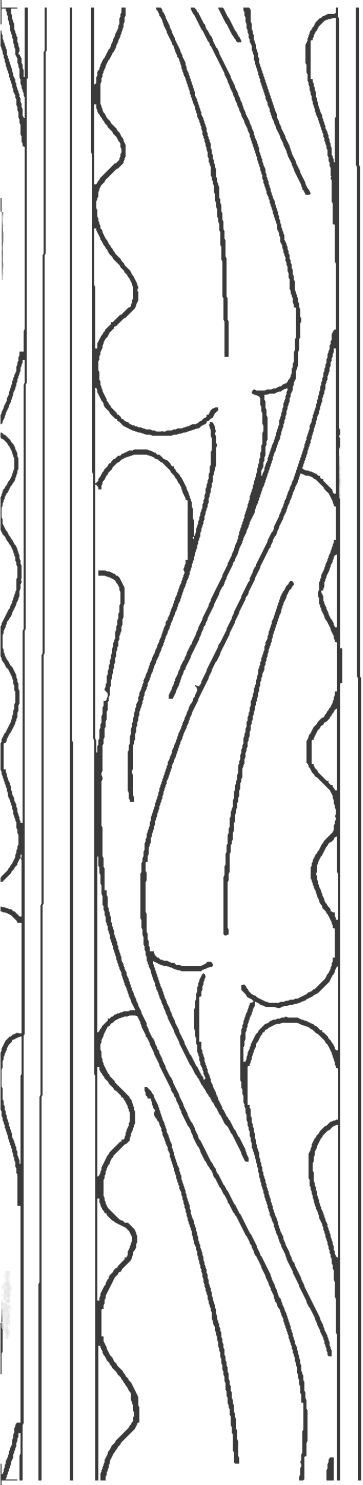
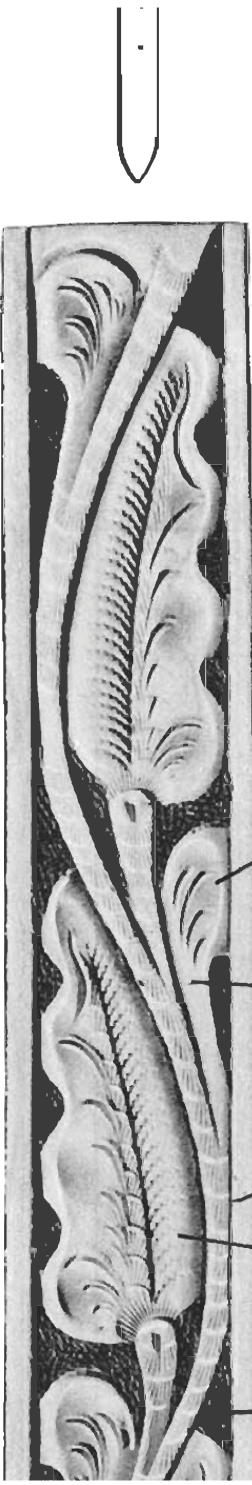

- alphabets
- helpful instructions

DISTRIBUTED BY TANDY WAREHOUSE CO., FORT WORTH, TEXAS
DIVISION OF TANDY CORPORATION

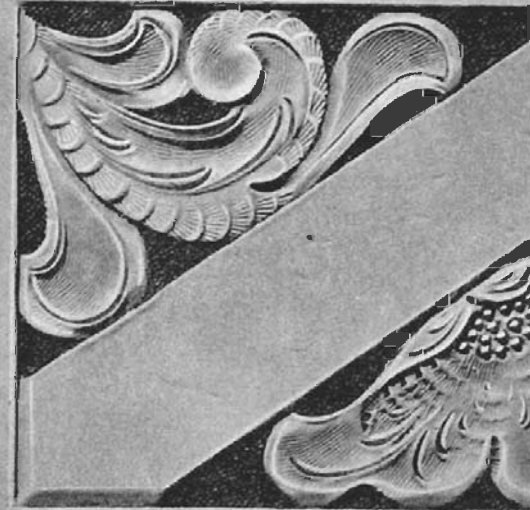
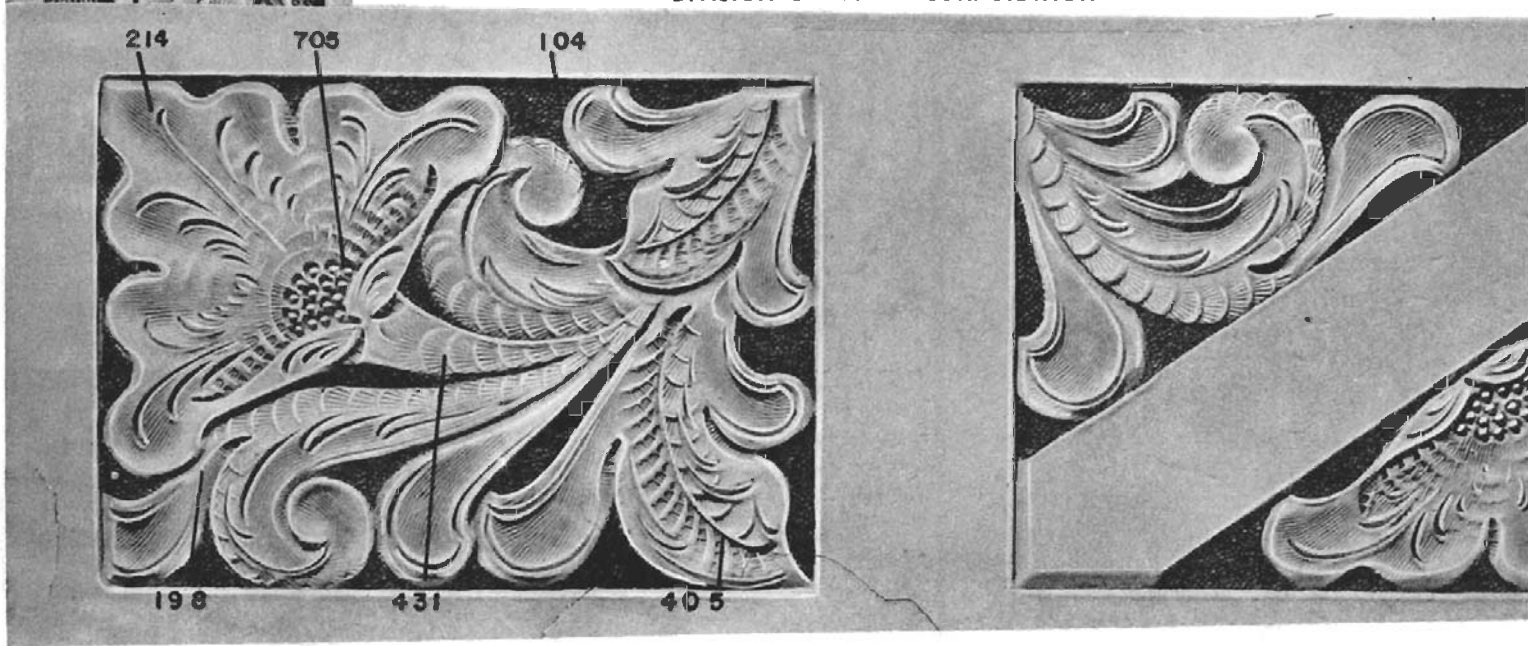

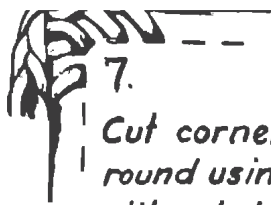

7.

Cut corners round using end slit or hole twice.

You may use corner three times.

8.



You are back to where you started. Notice dotted line lacing, this is removed so starting will appear as in No. 9.

9.



Note only one hole remains unlaced.

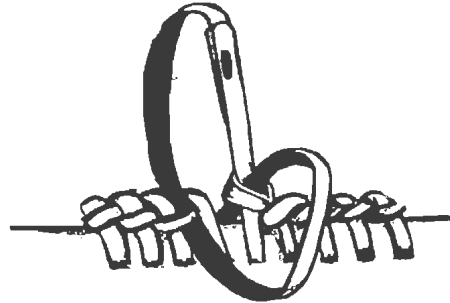

10. *Completion of Tie-in*

© Copyright 2010 by Tandy Leather Factory
All Rights Reserved

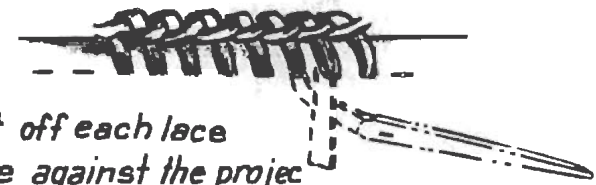

11. *Cut off each lace close against the project. Now, no one can tell where you started or stopped.*

After completing your lacing lay project on firm surface and beat lacing down with a mallet.

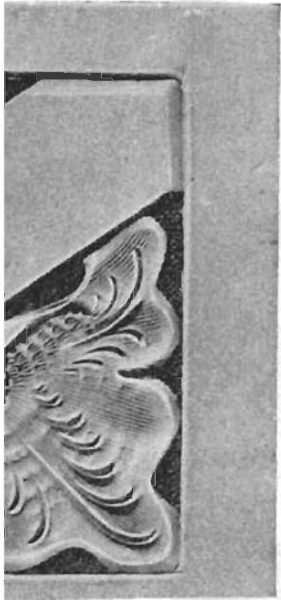

NO.54 BELT PATTERNS

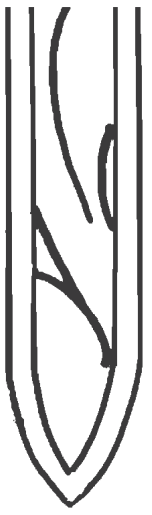
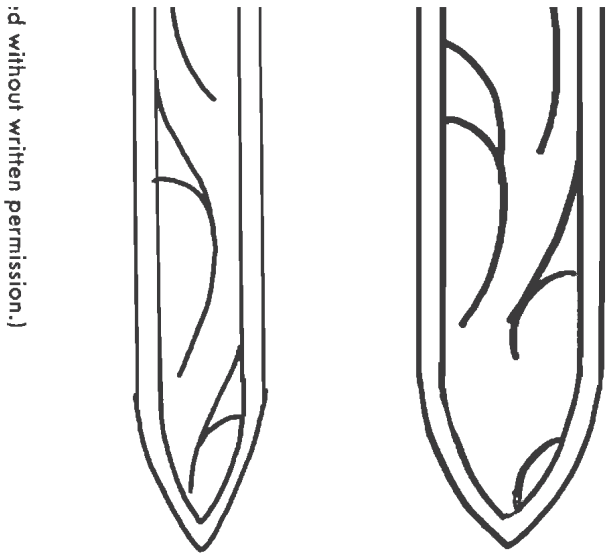
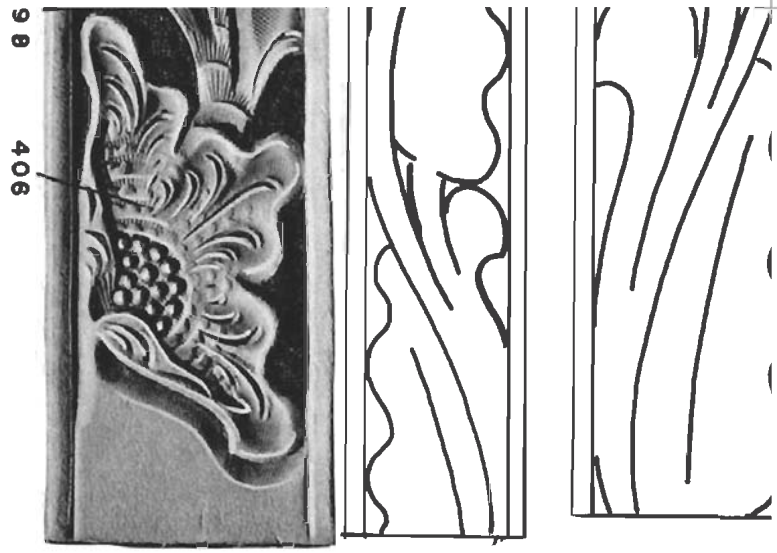

Handycraft

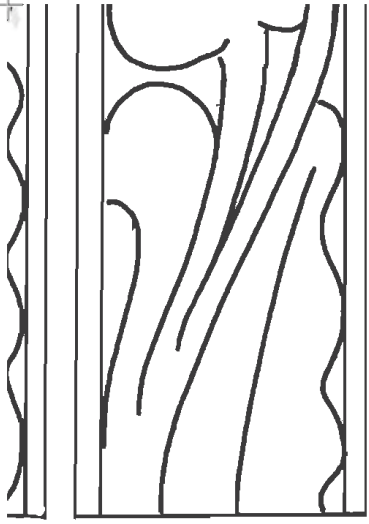

198



PERSONALIZE BELTS AND BILLFOLDS WITH THESE ALPHABETS **B E L O W**

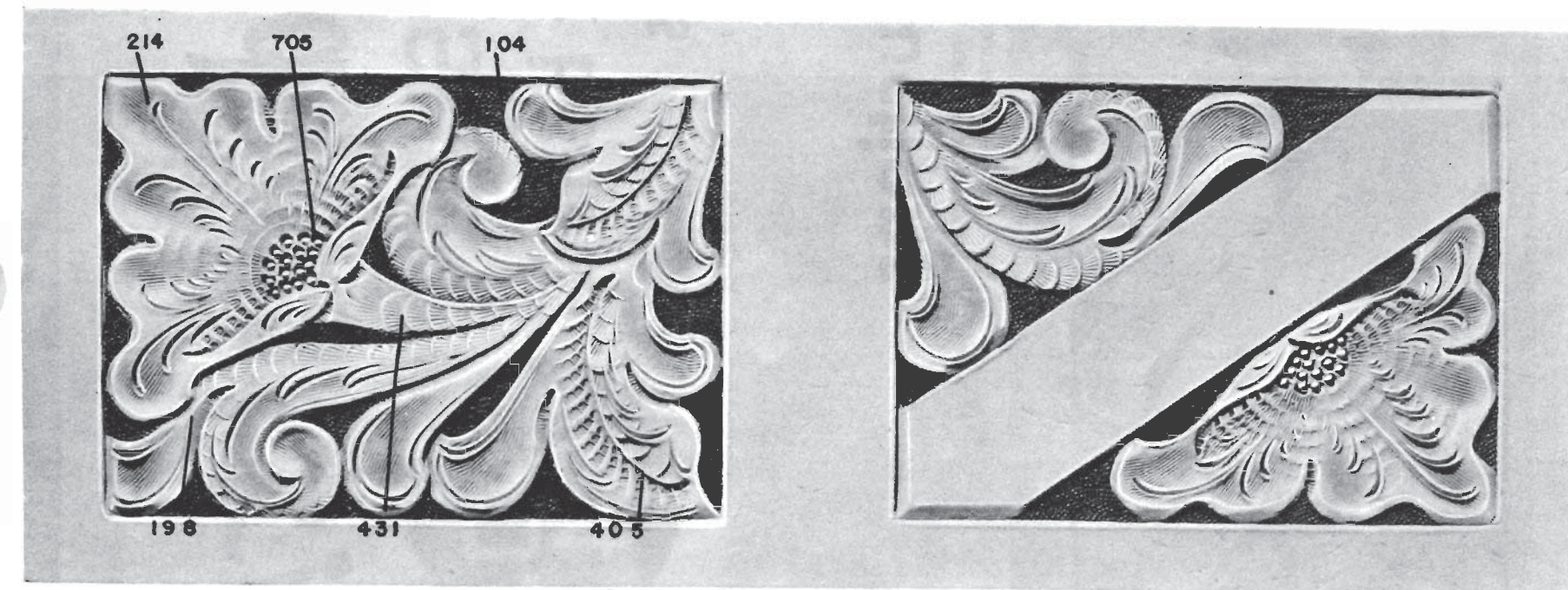
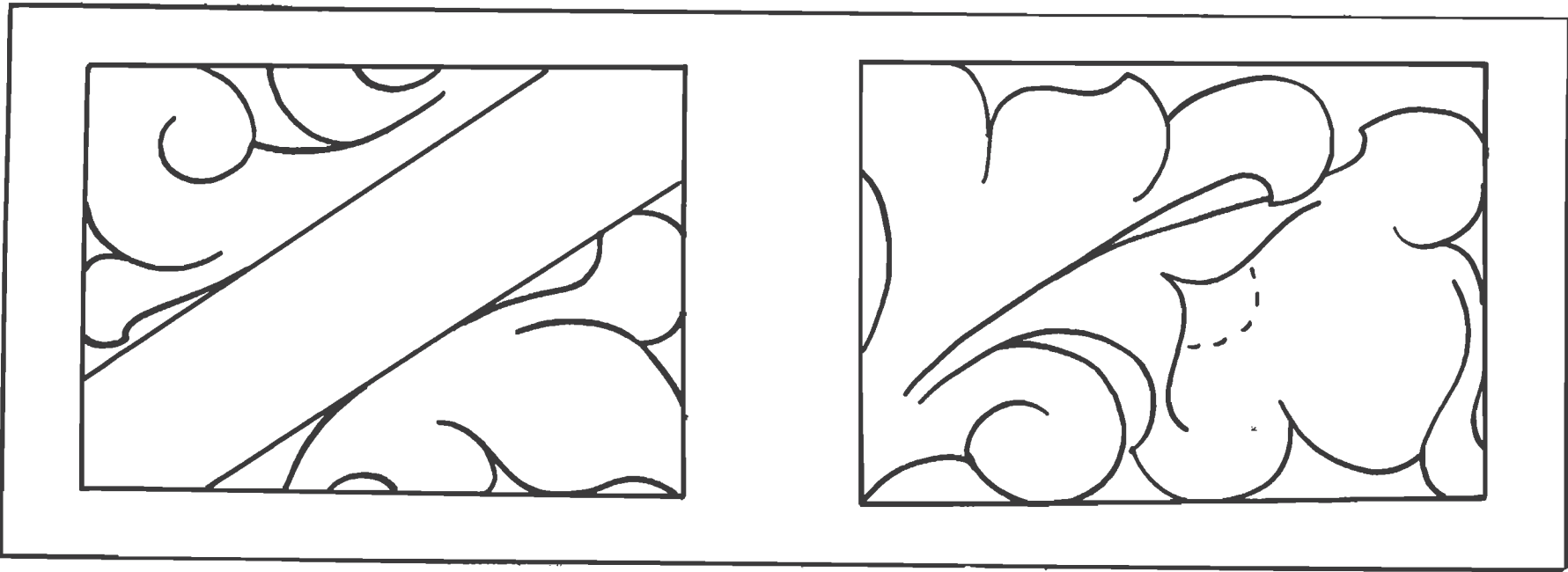
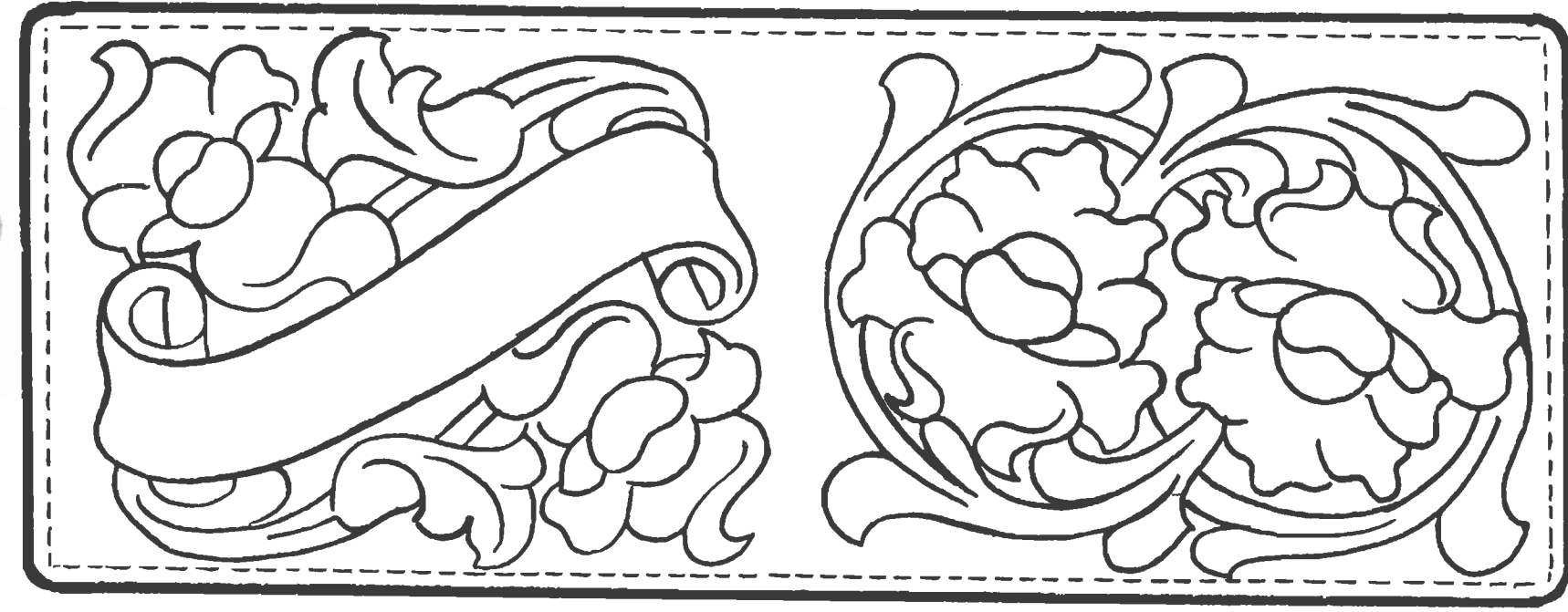
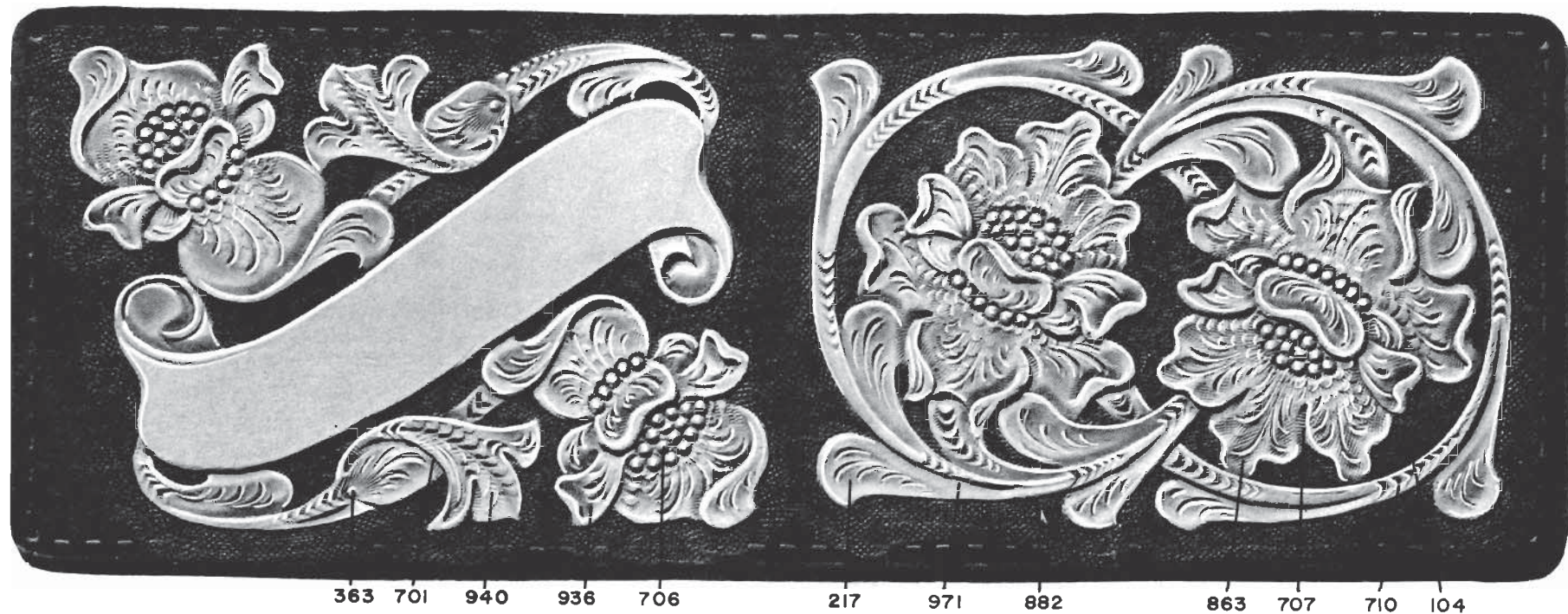

HOW TO CARVE YOUR LEATHER PROJECT

PREPARING THE LEATHER

A. Use a sponge to dampen leather.
 B. Spread the leather to be decorated grain or smooth side up on a smooth board. Dampen the entire piece. Do not get leather sopping wet.
 C. Use tracing paper to trace design outlines from pattern. Clip tracing to damp leather.

Step 1—Tracing Design
 A. Trace the outline of the design on leather with tracing tool or sharp pencil. If leather becomes dry, dampen it again. When it turns back to its natural color, resume work.

Step 2—Carving
 A. Use swivel knife to carve design. Cut outlines in the following order: flowers, stems, leaves, scrolls, etc.

Step 3—Camouflage
 Use camouflage to add roundness to scrolls, leaves, stems, etc.

Step 4—Shading
 Use shader to add shading or deep burnished color to leather... use on flower petals, leaves, etc.

Step 5—Beveling
 Use beveler to stamp down one side of cut only. Push beveler along inside of swivel cut. Smooth even bevel is very important.

Step 6—Viner and Seeder
 Use viner to add decorative effect on scrolls and flowers. Seeder to complete flower centers.

Step 7
 Use background tool to stamp down background areas, dark areas on pattern. Add decorative cut with your swivel knife.

When all tooling and stamping have been completed, clean and polish leather with Tan-Kote. Then apply a protective coating of Nash-Lac—Tandy's special leather finisher containing essential oils and waxes to preserve and protect leather.

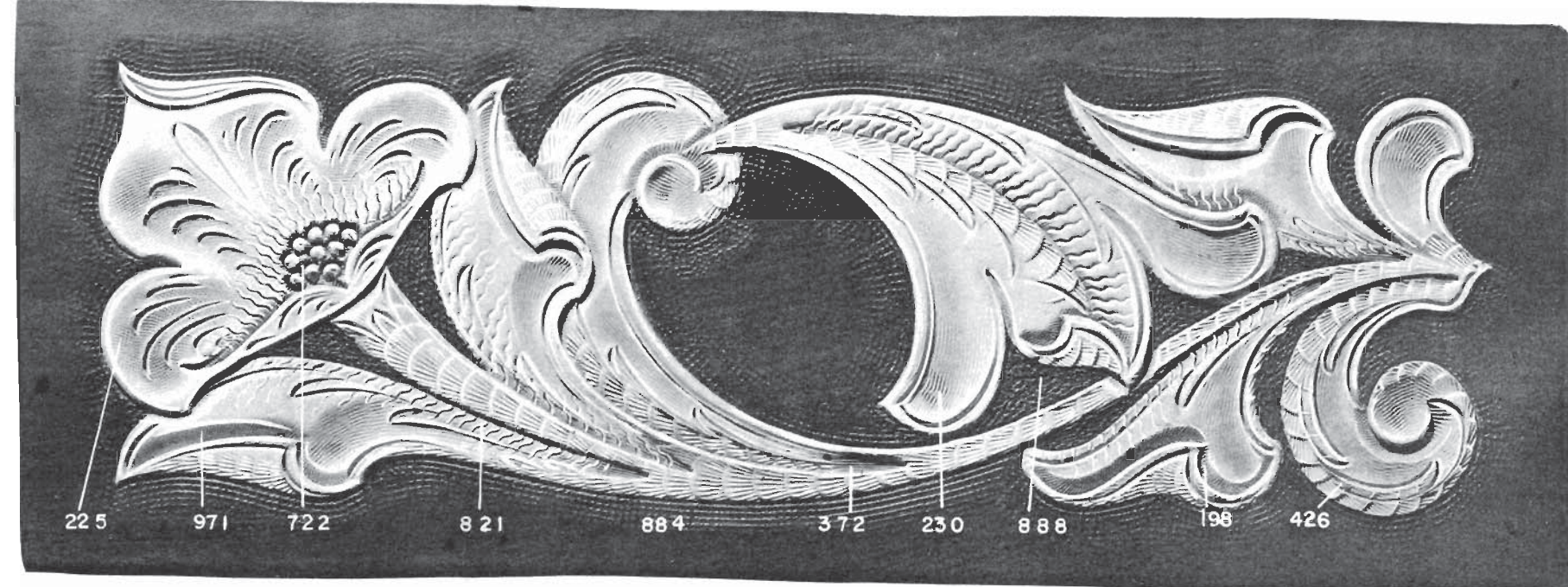
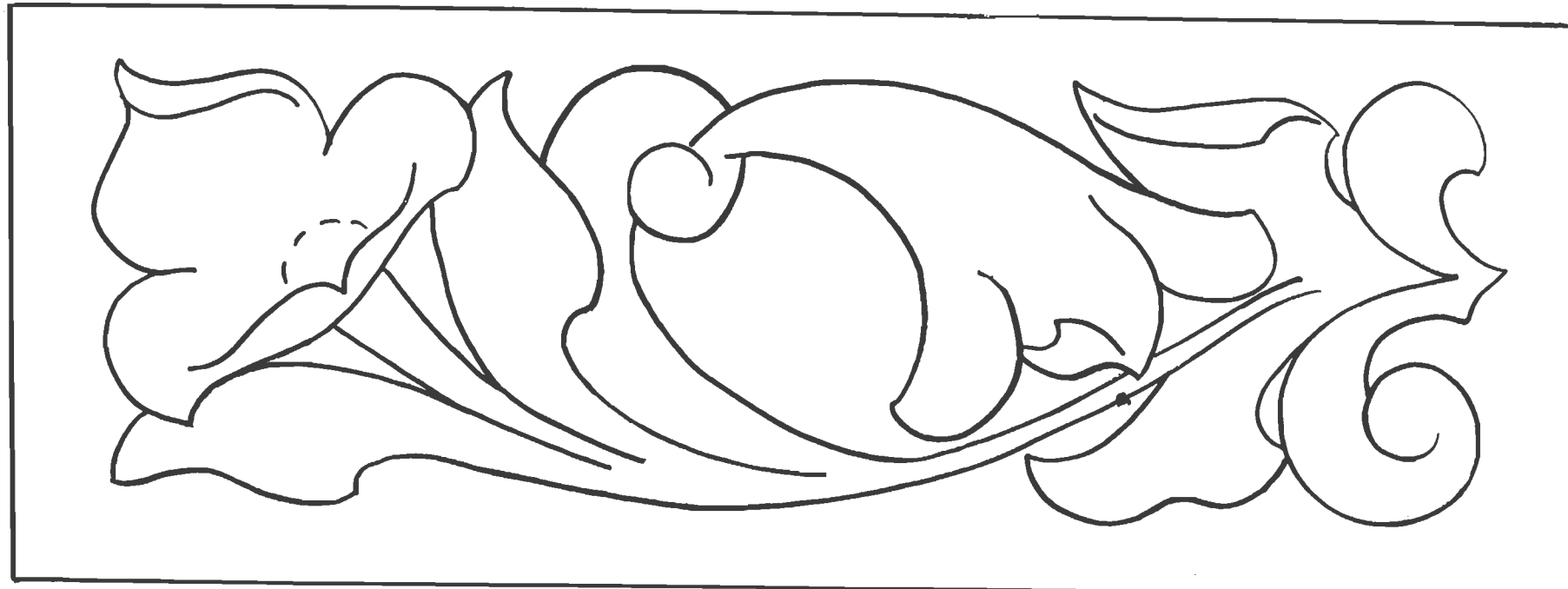
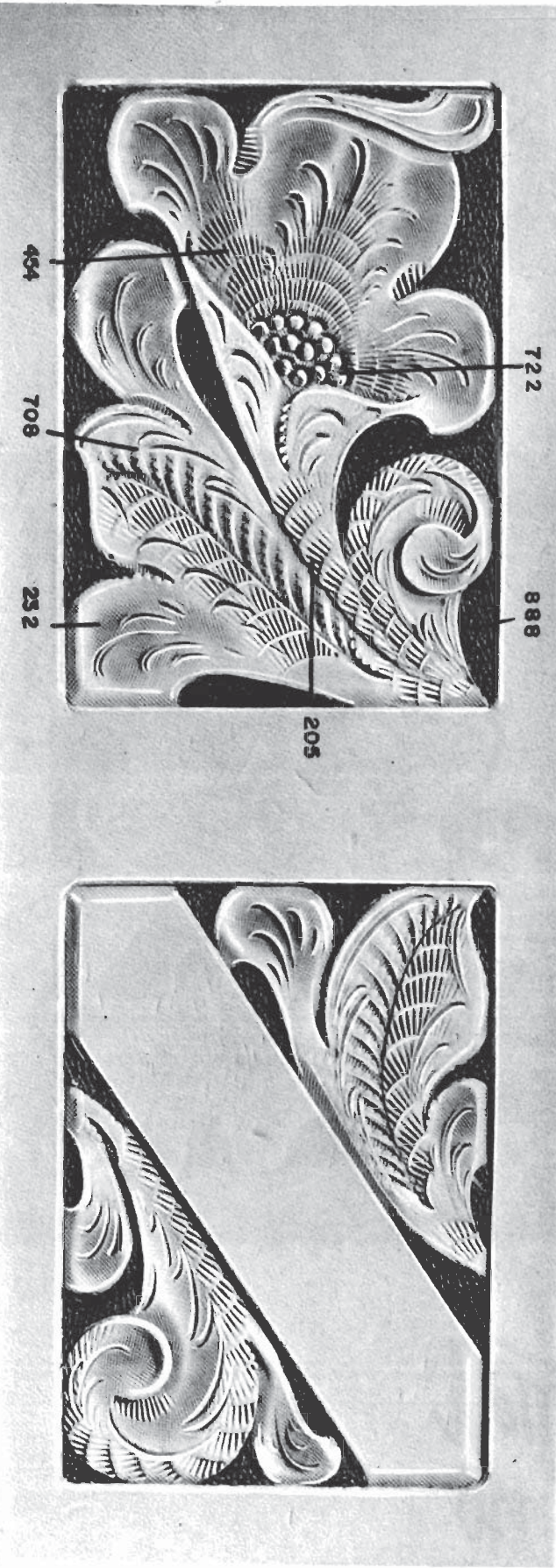

TAPER PATTERNS

HOW TO SHORTEN A TAPERED BELT.....

- CAREFULLY REMOVE SNAPS...
- MAKE A CARDBOARD PATTERN OF THE BUCKLE END OF BELT... SEE ILLUSTRATION...
- PLACE PATTERN ON BUCKLE END OF BELT... ALLOW SAME DISTANCE FROM END OF BELT TO END OF PATTERN AS BELT IS TO BE SHORTENED... MARK SNAP HOLES, SLOT, & OUTLINE WITH STYLUS... SEE ILLUSTRATION...
- TRIM TO NEW LINES & PUNCH HOLES... REFER TO PAGE 9
- ROUND EDGES WITH EDGER... BURNISH INSTALL SNAPS... SEE PAGE 9

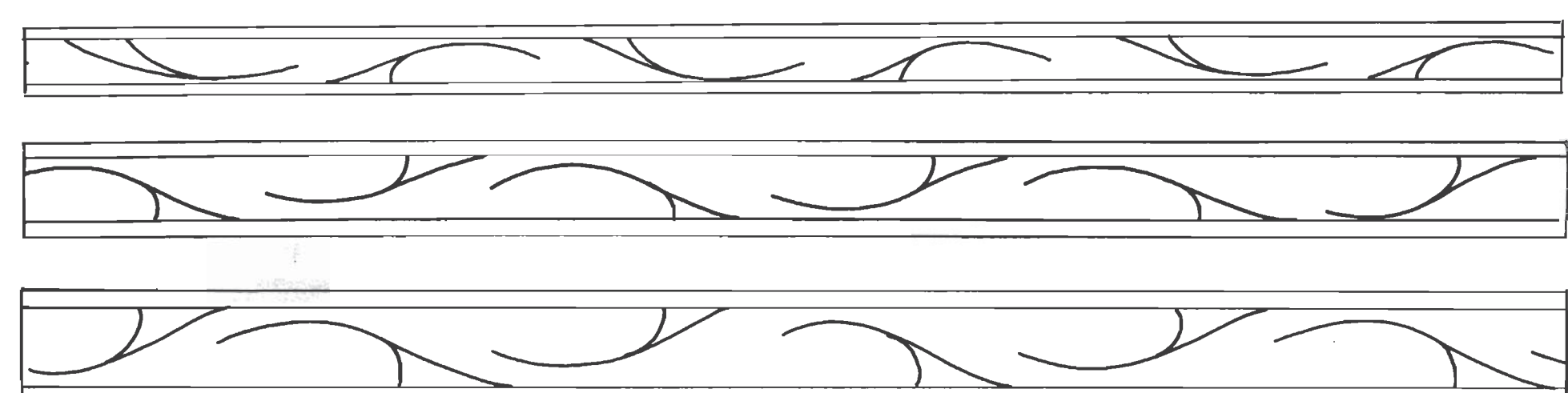
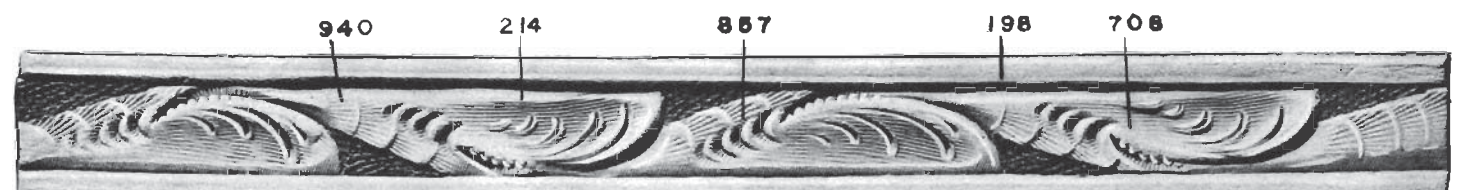
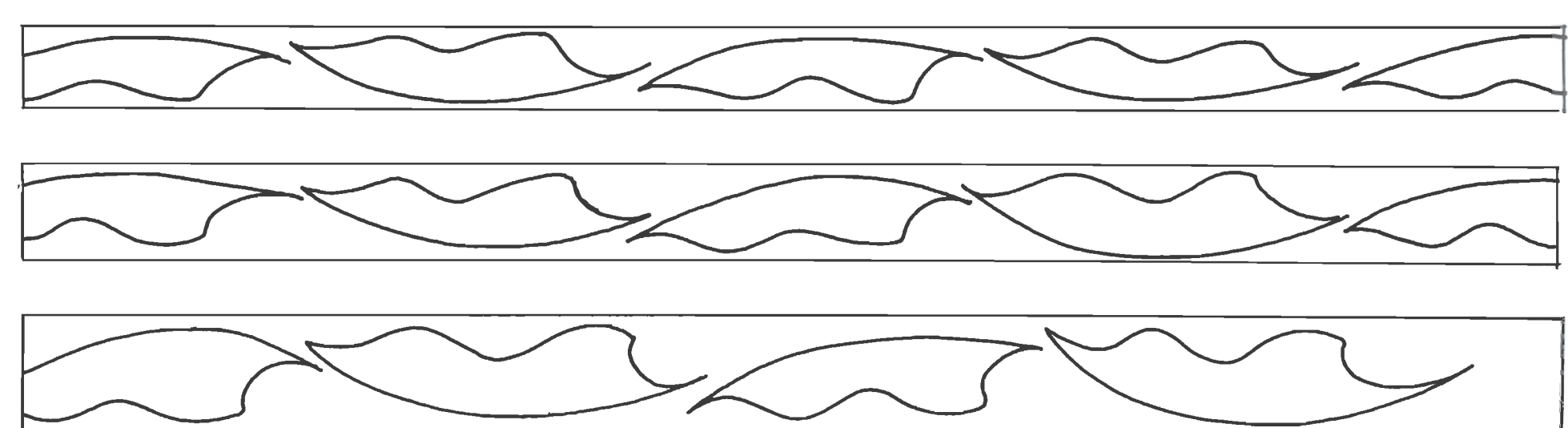
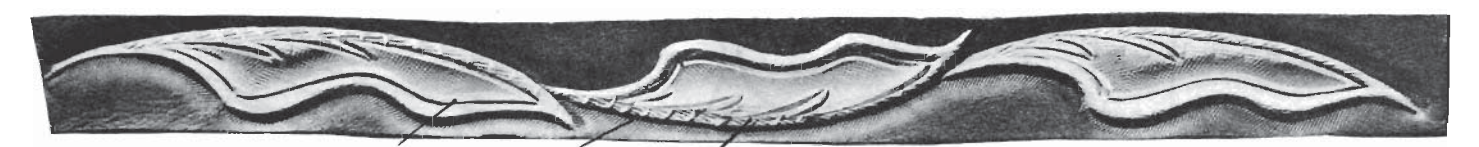
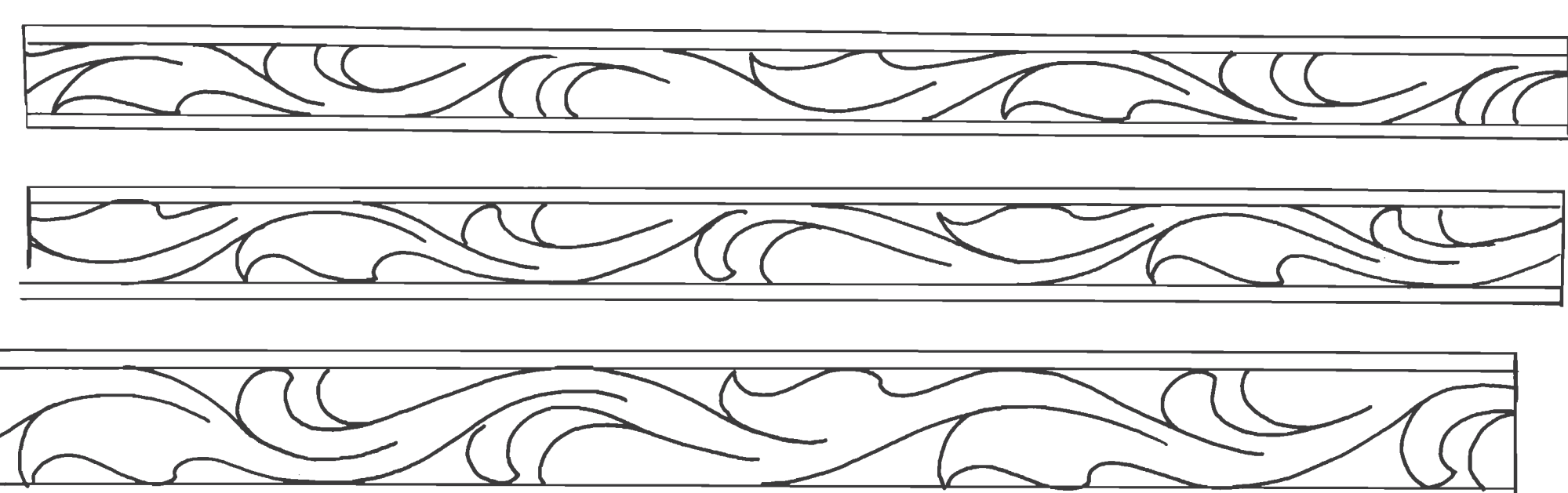
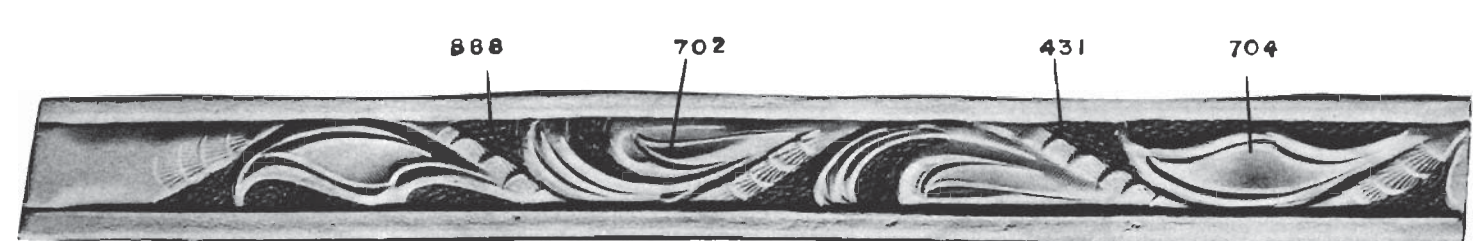
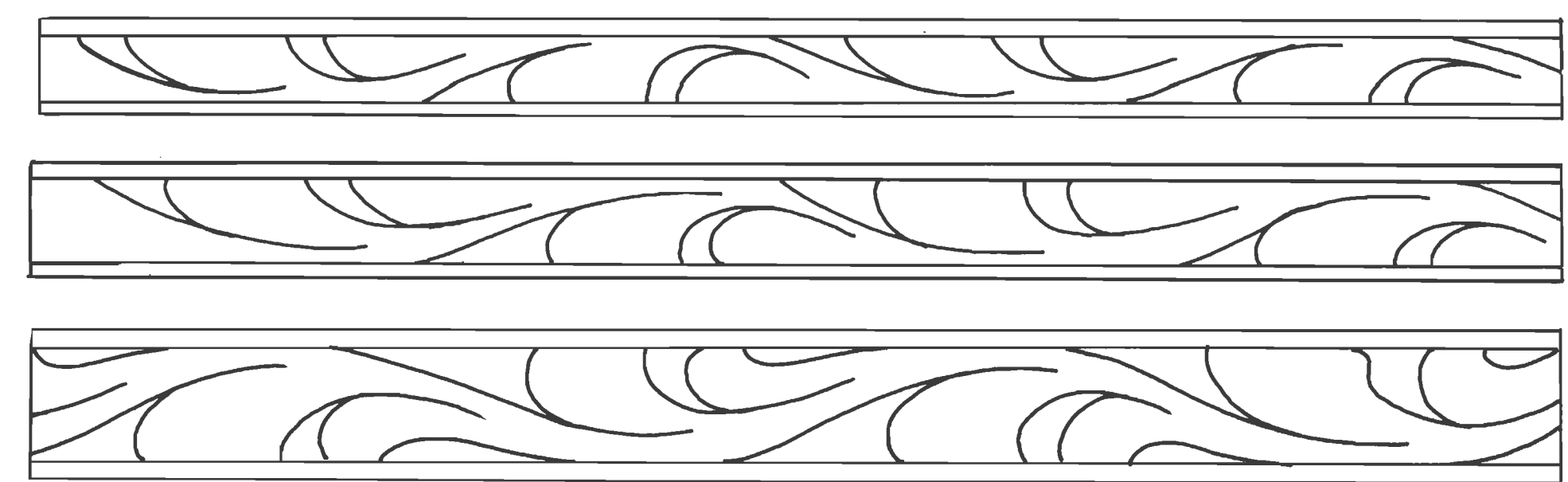
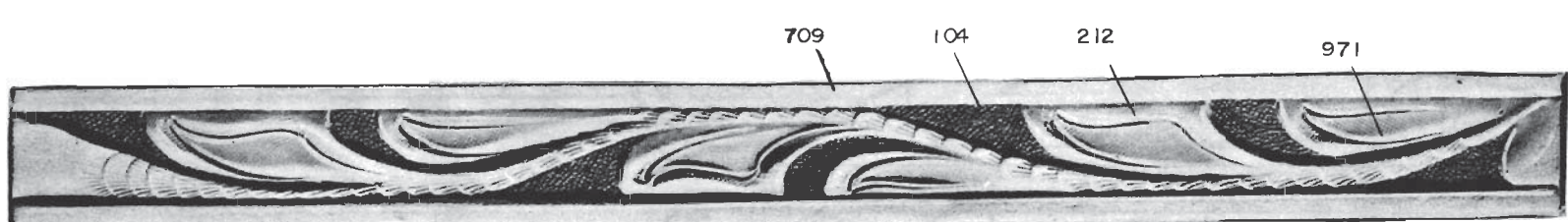

PERSONALIZ

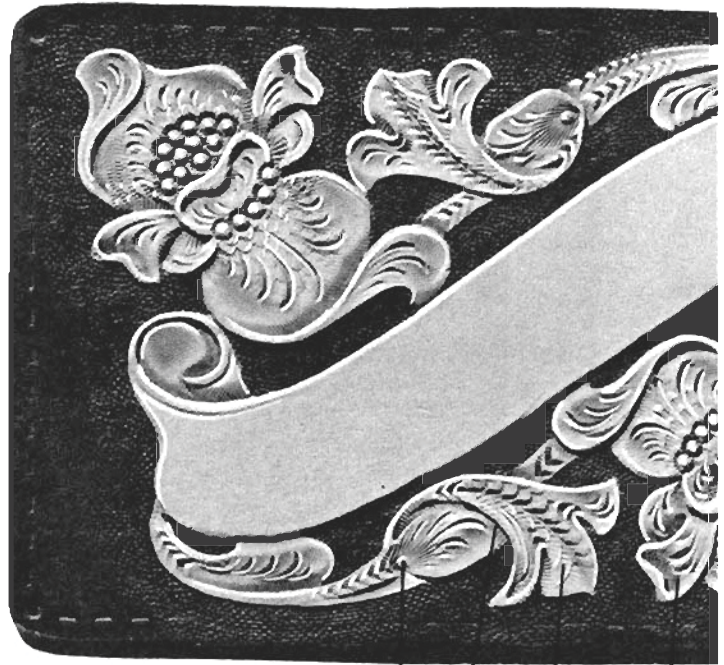

363 701 940 936



THE BELTS AND BILLFOLDS



706 217 971 882 863 707 710 104

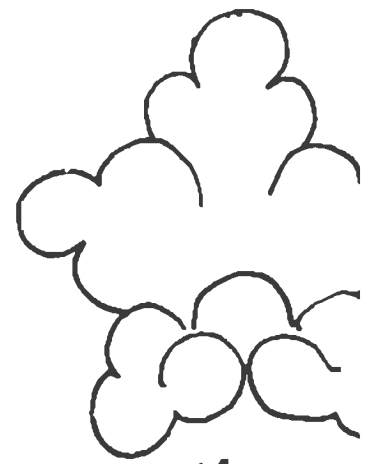

It's New

Stano

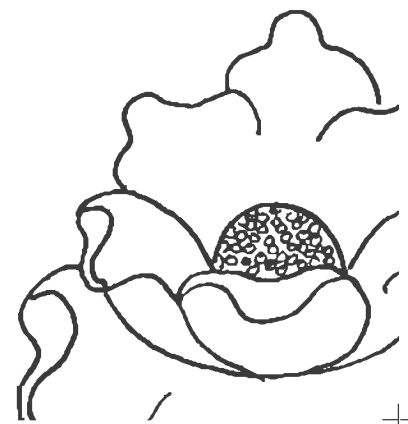

3 WITH THESE ALPHABETS

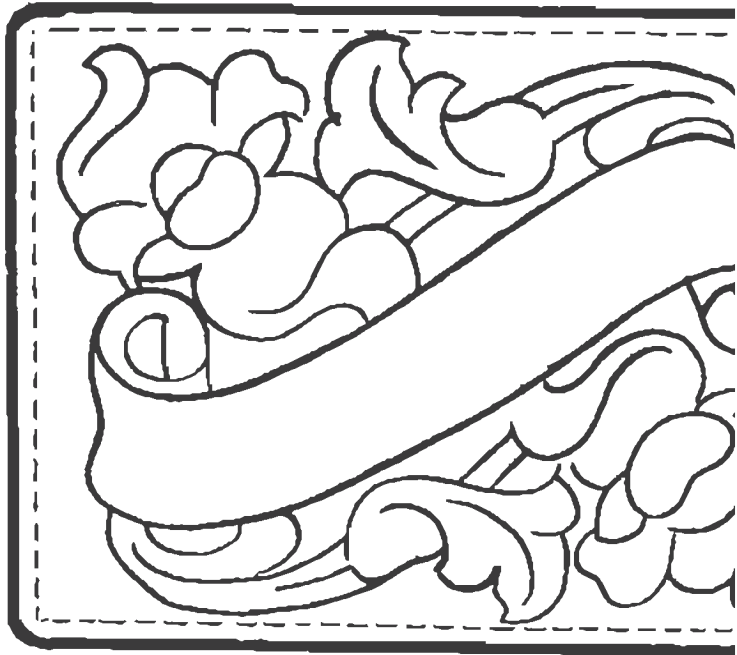

lycraft!

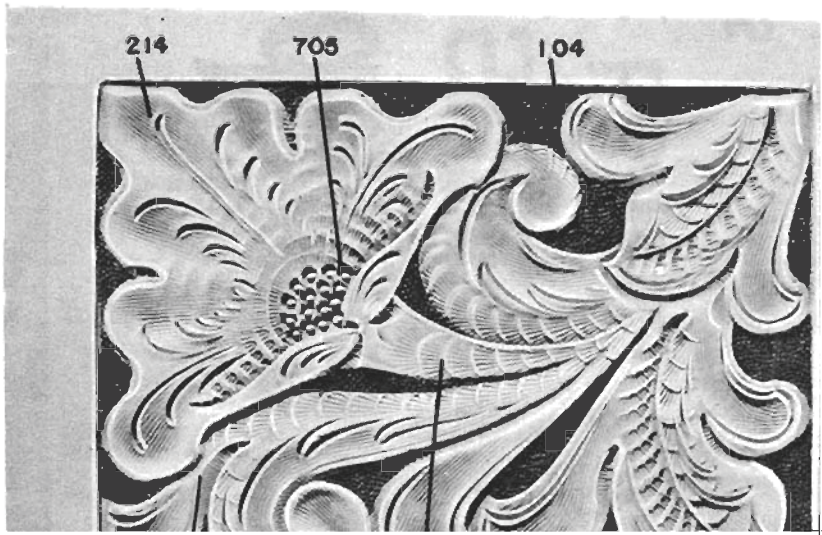
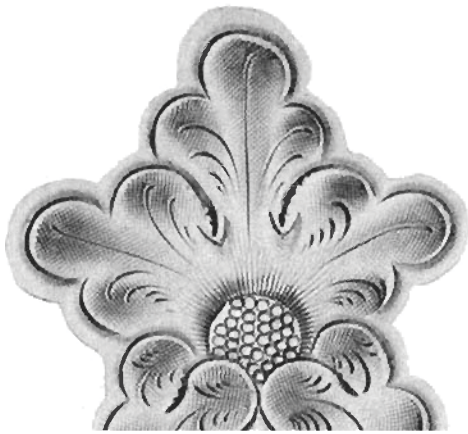

TS **B** **E** **L** **O** **W**

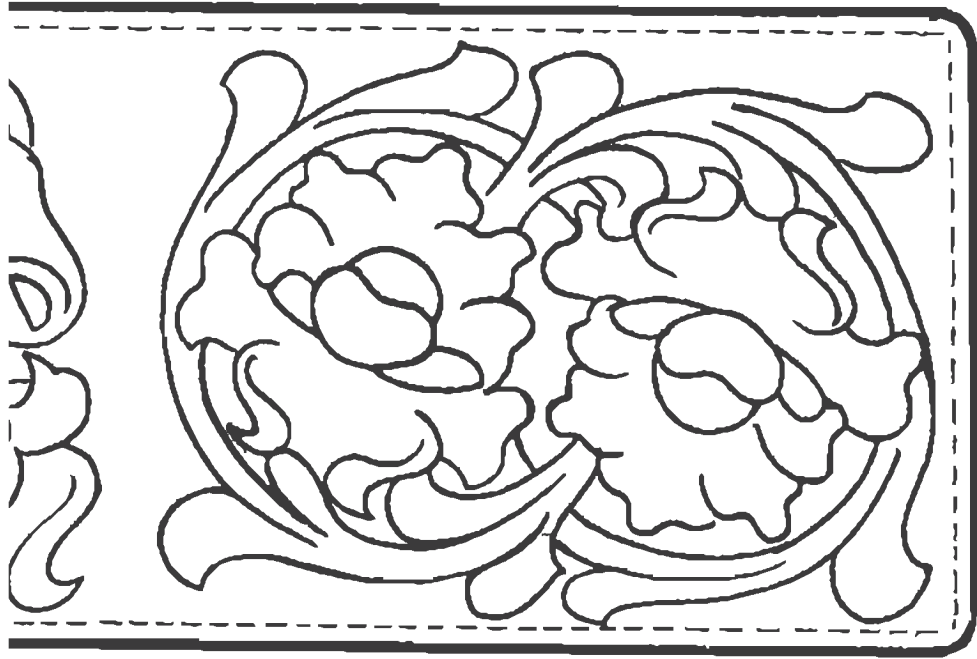



205



PREPARING THE LEATHER

- A. Use a sponge to dampen leather.
- B. Spread the leather to be decorated grain or smooth side up on a smooth board. Dampen the entire piece. Do not get leather sopping wet.
- C. Use tracing paper to trace design outlines from pattern. Clip tracing to damp leather.

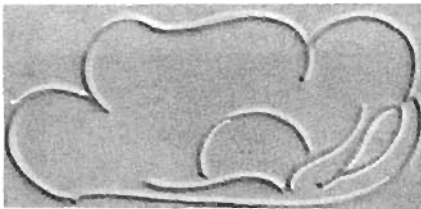

Step 1—Tracing Design

Step 1—Tracing Design

- A. Trace the outline of the design on leather with tracing tool or sharp pencil. If leather becomes dry, dampen it again. When it turns back to its natural color, resume work.

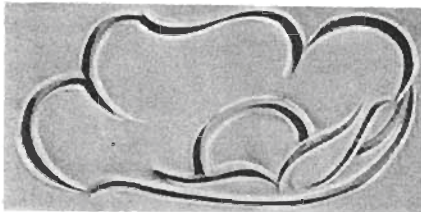

Step 2—Carving

Step 2—Carving

- A. Use swivel knife to carve design. Cut outlines in the following order: flowers, stems, leaves, scrolls, etc.

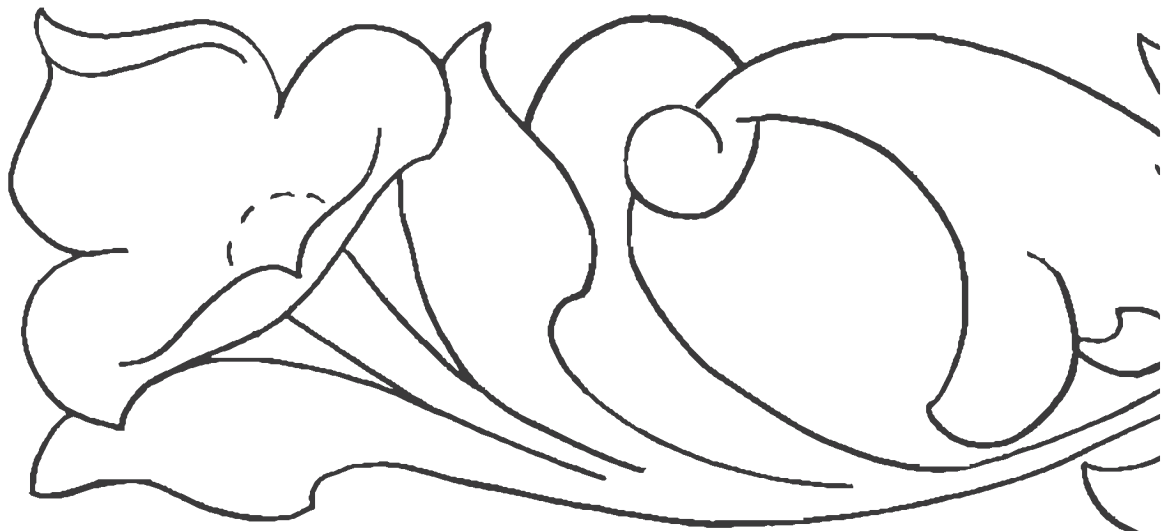
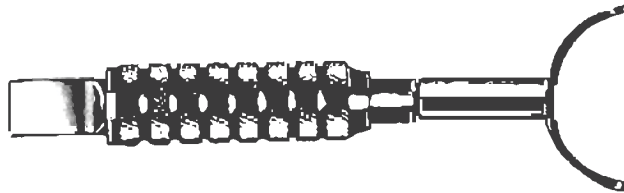

HOW TO CARVE YOUR LEATHER PROJECT

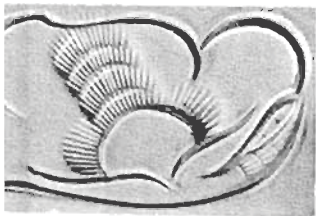

Step 3—Camouflage.

Step 3—Camouflage—Use camouflage to add roundness to scrolls, leaves, stems, etc.

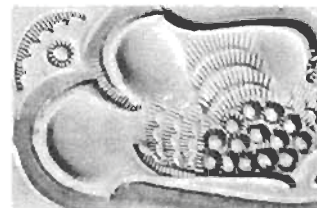

Step 6—Veiner - and !

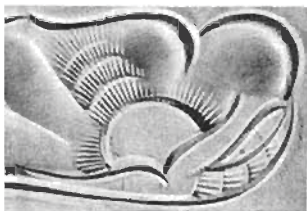

Step 4—Shading

Step 4—Shading—Use shader to add shading or deep burnished color to leather... use on flower petals, leaves, etc.



Step 7

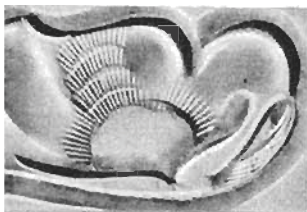

Step 5—Beveling

Step 5—Beveling—Use beveler to stamp down one side of cut only. Push beveler along inside of swivel cut. Smooth even bevel is very important.



When all leather is carved, use Tandy's leather preservative to preserve it.

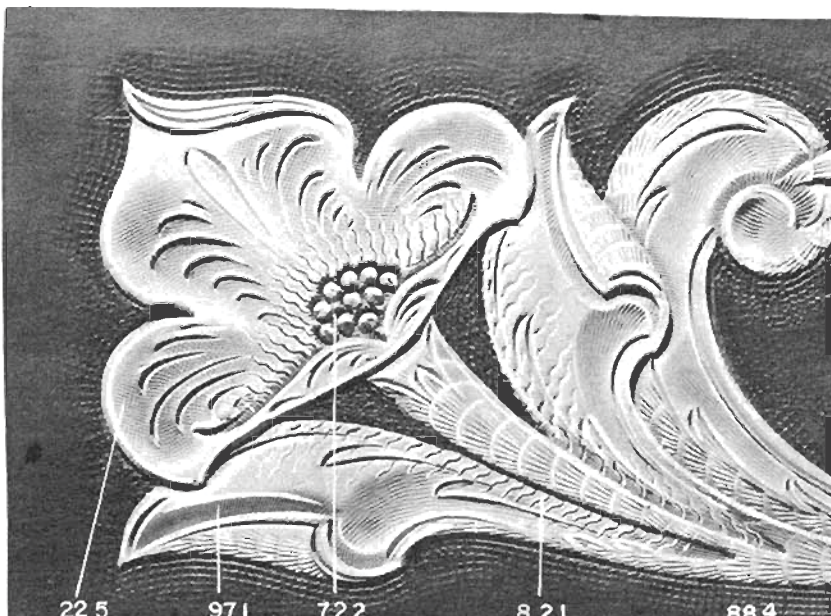
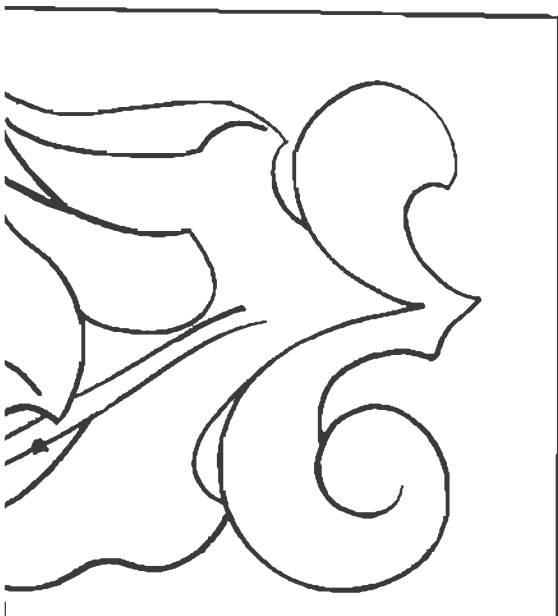



Step 6—Vainer - and Seeder—Use vainer to add decorative effect on scrolls and flowers. Seeder to complete flower centers.



Seeder

Step 7—Use background tool to stamp down background areas, dark areas on pattern. Add decorative cuts with your swivel knife.



If tooling and stamping have been completed, clean and polish with Tan-Kote. Then apply a protective coating of Neat-Lac /'s special leather finisher containing essential oils and waxes to preserve and protect leather.

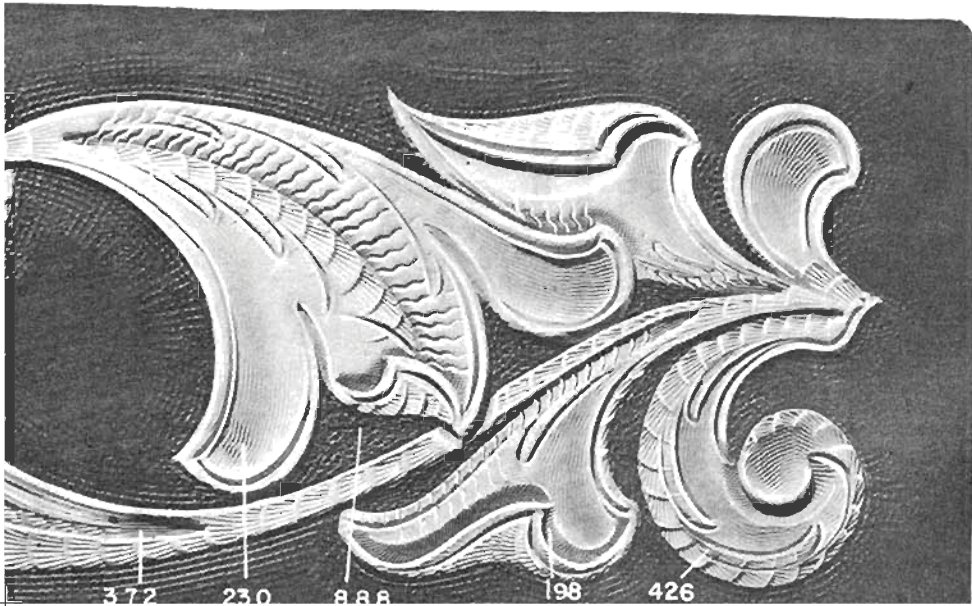

J. 54 BELT PATTERNS

© Copyright by Tandy Leather Factory
All Rights Reserved

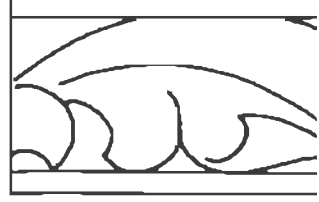
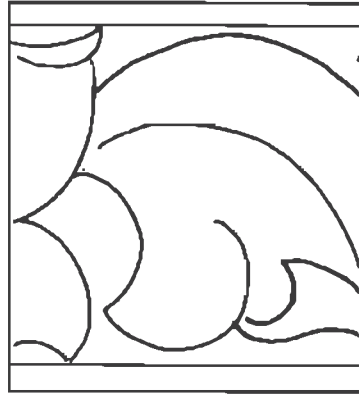

431

406



748

104

213

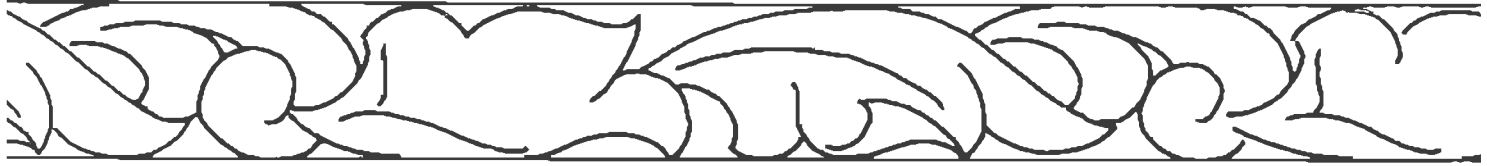

TAPER

709

104

212

971



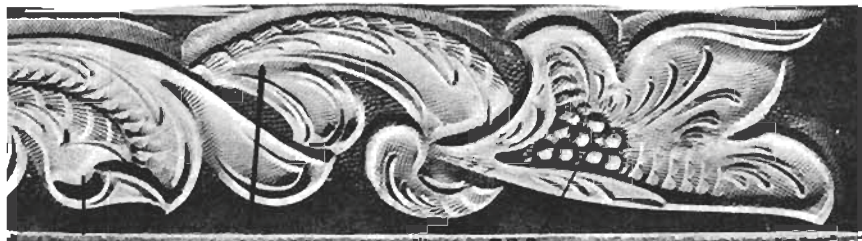

701

971

122

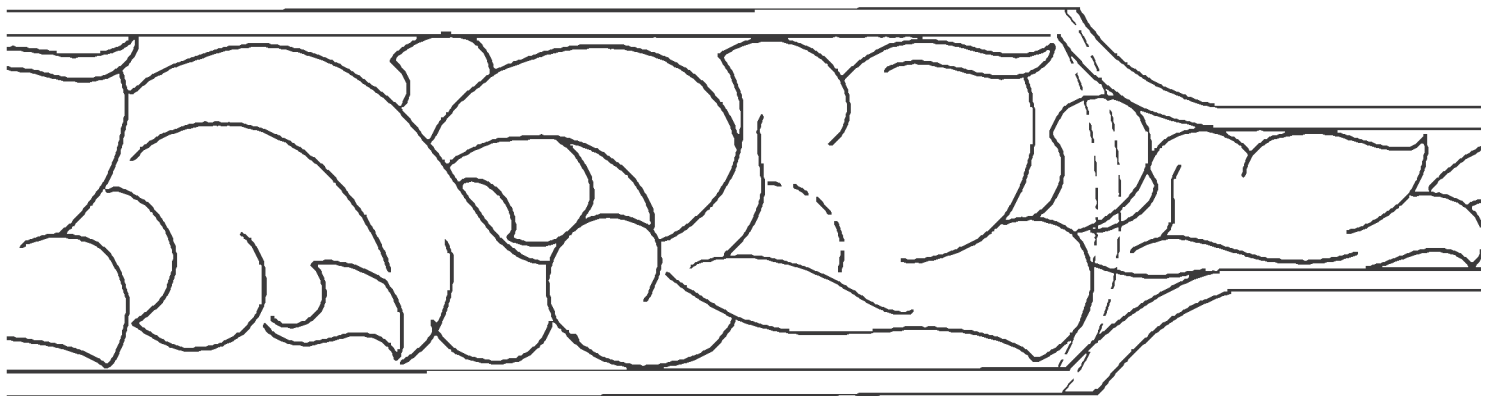
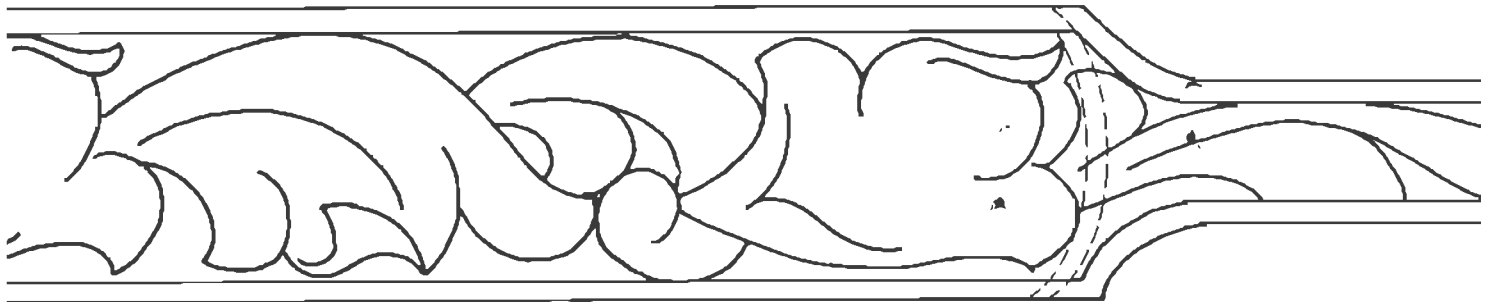
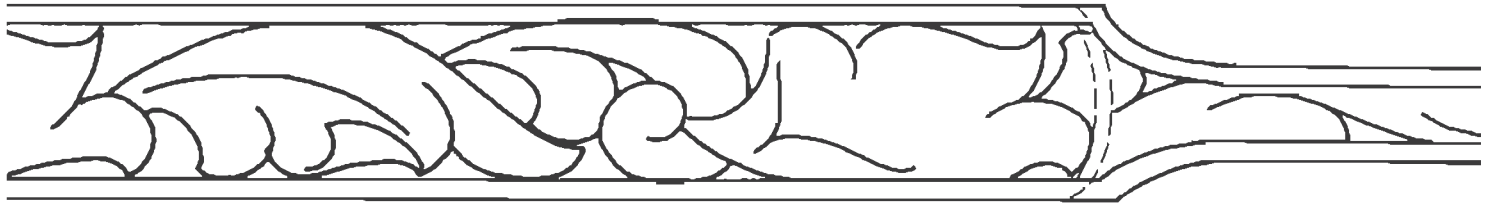

PATTERNS

HOW TO SHORTEN

- ① CAREFULLY REMOVE SNAPS...
- ② MAKE A CARDBOARD PATTERN OF THE BUCKLE END OF BELT... SEE ILLUSTRATION...
- ③ PLACE PATTERN ON BUCKLE END OF BELT... ALLOW SAME DISTANCE FROM END OF BELT TO END OF PATTERN AS BELT IS TO BE SHORTENED... MARK SNAP HOLES, SLOT, &



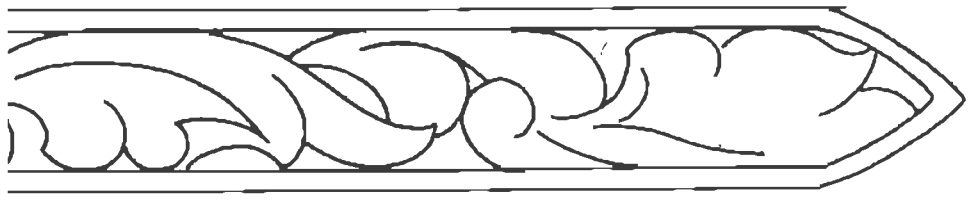
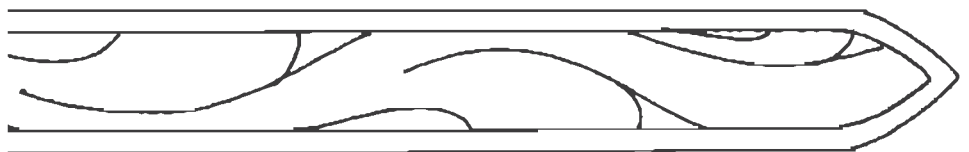

A TAPERED BELT.....

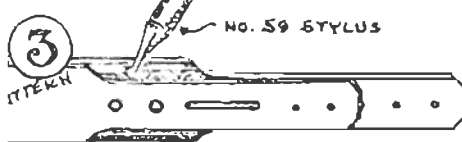
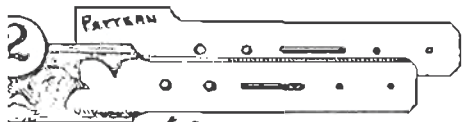

4 TRIM TO NEW LINES
& PUNCH HOLES.....
REFER TO PAGE 9

5 ROUND EDGES WITH
EDGER.... BURNISH
INSTALL SNAPS..
SEE PAGE 9

OUTLINE WITH STYLUS... SEE ILLUSTRATION...

tandycraft

NE

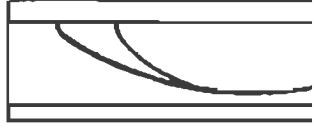
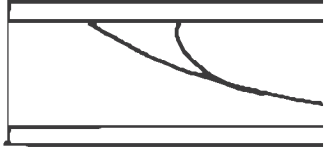
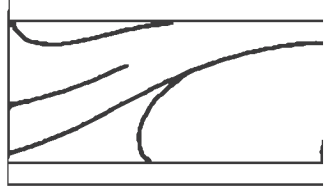
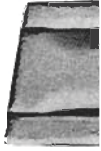
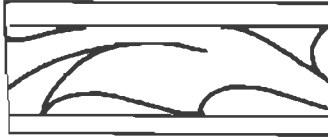
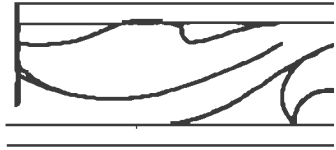
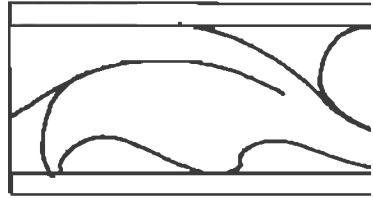

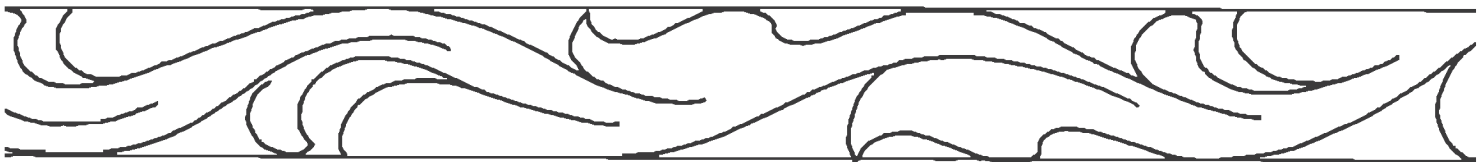
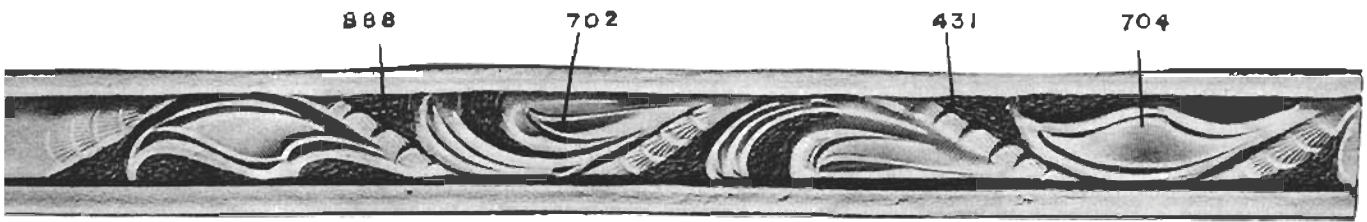

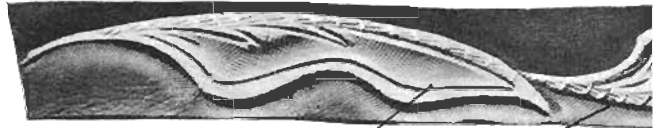

213

205

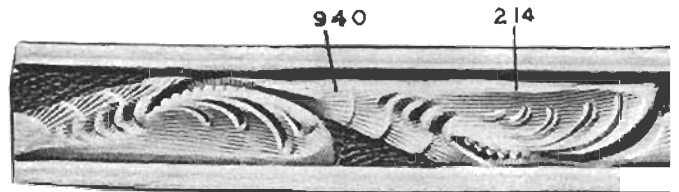
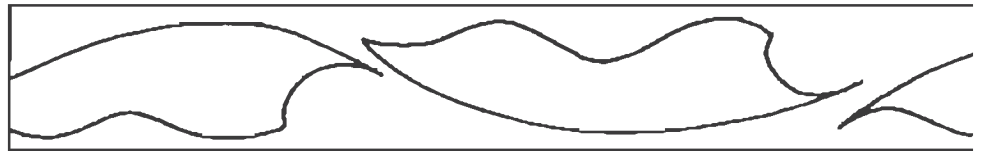

940

214

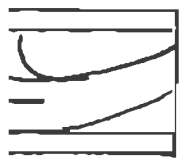
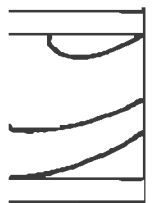
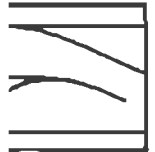
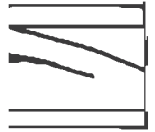
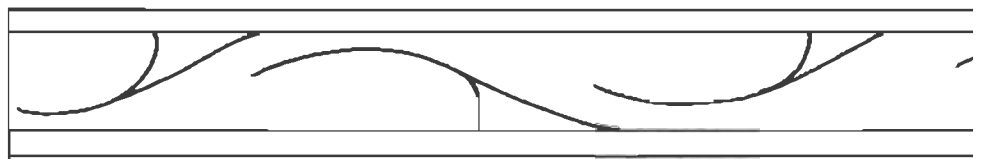
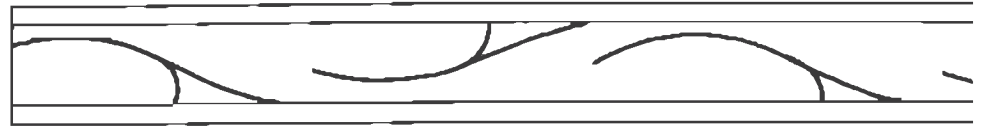



431

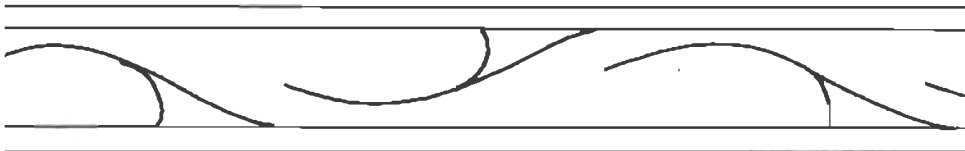
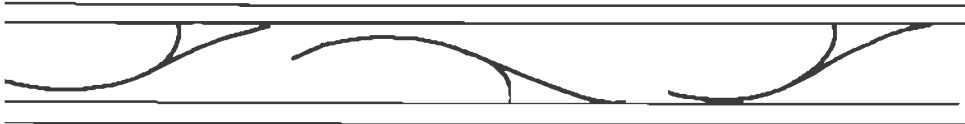
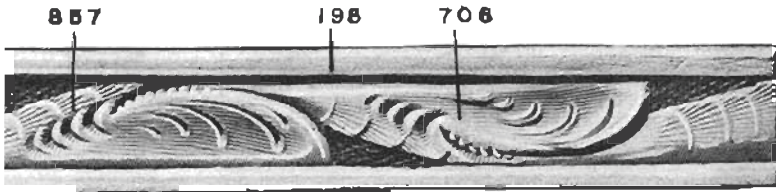
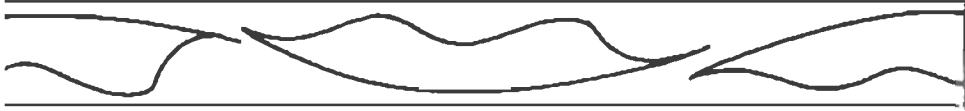

Billfold Insides

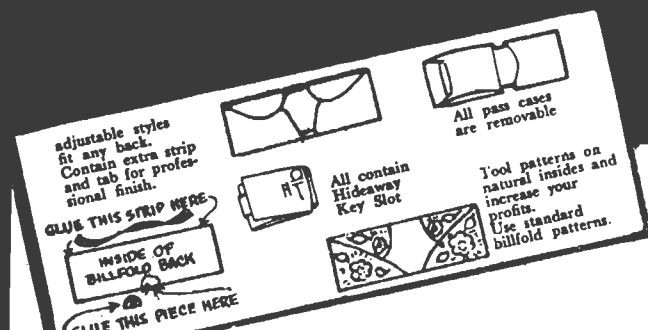

Quality popular style liners fit for your finest billfolds. Professionally finished, superbly tailored. Die-cut Grade A leathers, machine stitched, securely glued. Complete ready to lace to back.

FOR MORE FINE ACCESSORIES, CHECK TANDY'S LATEST CATALOG!

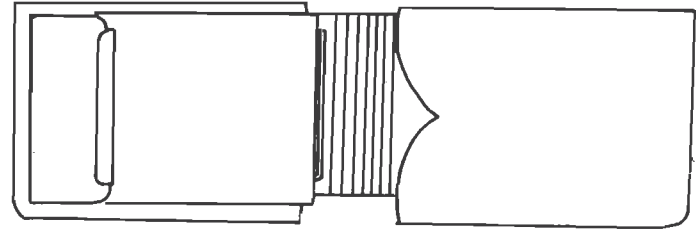

DIPLOMAT

Elegant, finest quality calfskin; die-cut, machine stitched, securely glued. Adjustable; fits any size billfold back. 4 leaf pass case, brass metal tab. Creased center for smooth flat fold. Colors: Black, brown or natural.

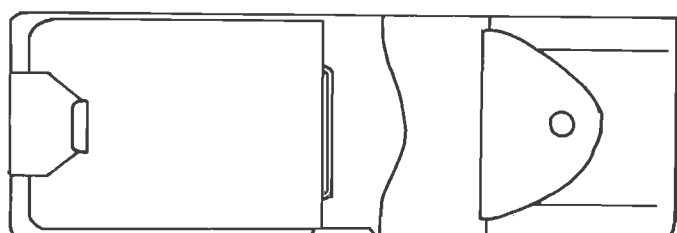

TRADER

Quality calfskin, precision cut. Machine stitched, securely glued. Non-adjustable size 8 7/8" x 3 1/8". Pleated coin purse expands to hold plenty of change. Removable 4 leaf pass case. Brass tabs. Colors: 2 tone brown and natural, brown, natural and black.

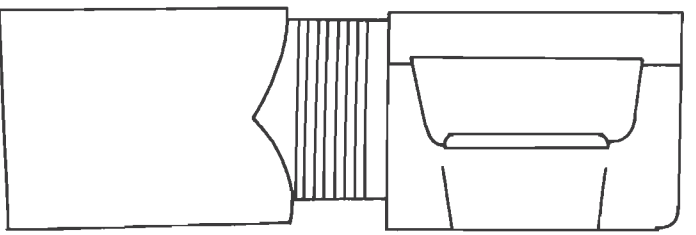

BANKER

Beautiful, finest quality calfskin, superbly tailored. Die-cut Grade A leather, machine stitched, securely glued. Adjustable size; fits any billfold back. Expansion coin purse, brass metal tabs. Center crease for smooth flat fold. Colors: Black, brown, natural.

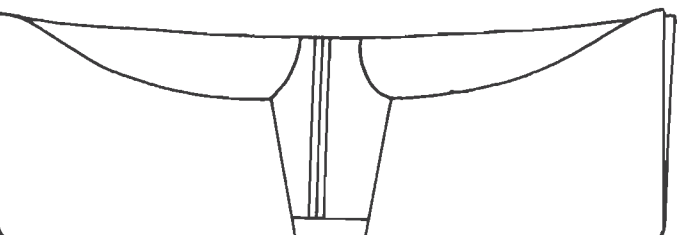

EXECUTIVE

Popular executive style billfold. Die cut from Grade A calfskins. Machine stitched, securely glued. Words "cards" and "purses" stamped in leather. Feature extra strip and tab to cement inside billfold back for finest professional finish. Colors: 1-A Black; 1-B Brown; 1-C Natural; 1-D Two tone black and natural; 1-E Two tone brown and natural.

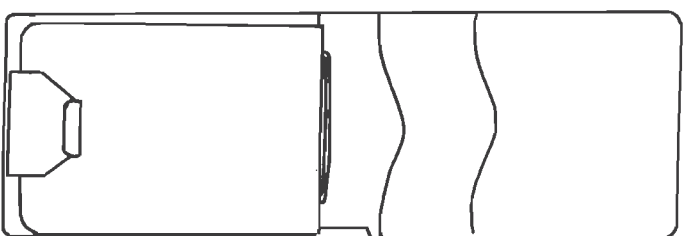

MERCHANT

Quality calfskin, precision cut. Machine stitched. Non-adjustable size 9" x 3 1/8". Three pockets and removable 4 leaf pass case. Brass tabs. Colors: 2 tone brown and natural, natural, brown and black.

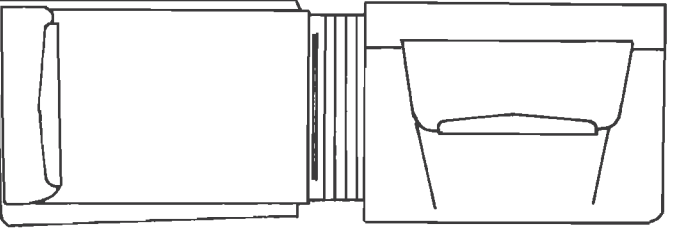

COSMOPOLITAN

Billfold Inside. Combines best features of popular style billfolds. Beautiful tooling calf can be carved to match billfold back. Expansion coin purse; folding removable card case; 2 wing inserts. Extra pocket inside card case. Metal tabs attached; snap set. Fits any size billfold back. Colors: Natural, Black, Brown.

(No part of this or any other page may be reproduced without written permission.)

It's New - Tandycraft!

SEND FOR THESE CRAFTAIDS ESPECIALLY DESIGNED FOR FRATERNAL ORGANIZATIONS

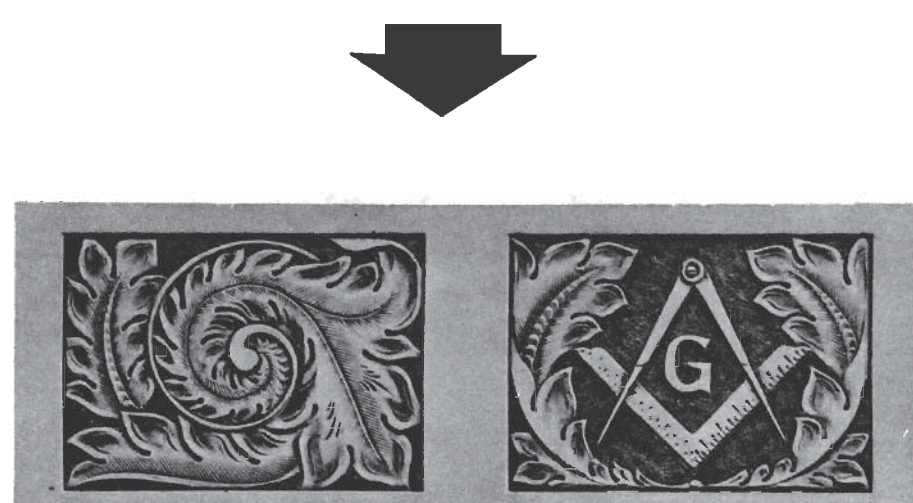

Tandy LEATHER COMPANY

"WRITE FOR LATEST CATALOG PRICE LIST" WRITE DEPT. A.



How to find Center for NAME BELTS

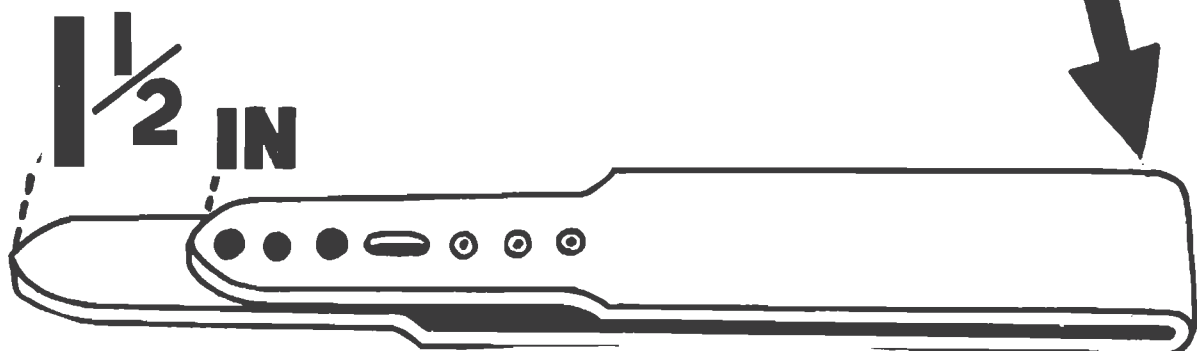

PRINTED IN U.S.A.

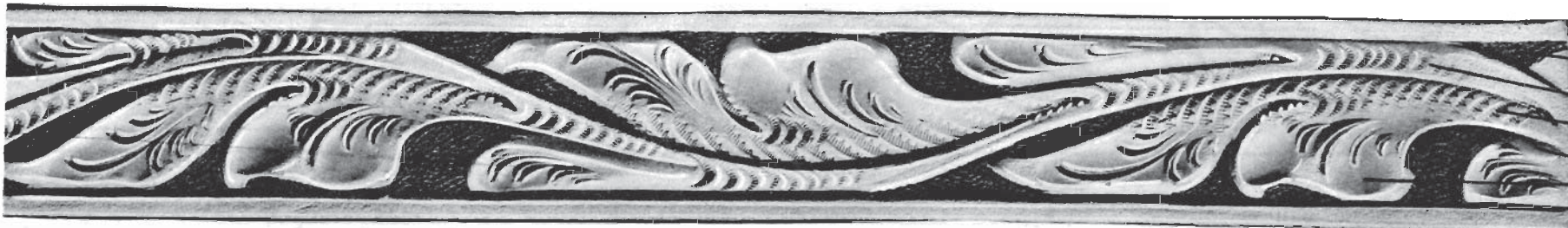

888
857
708
971
222

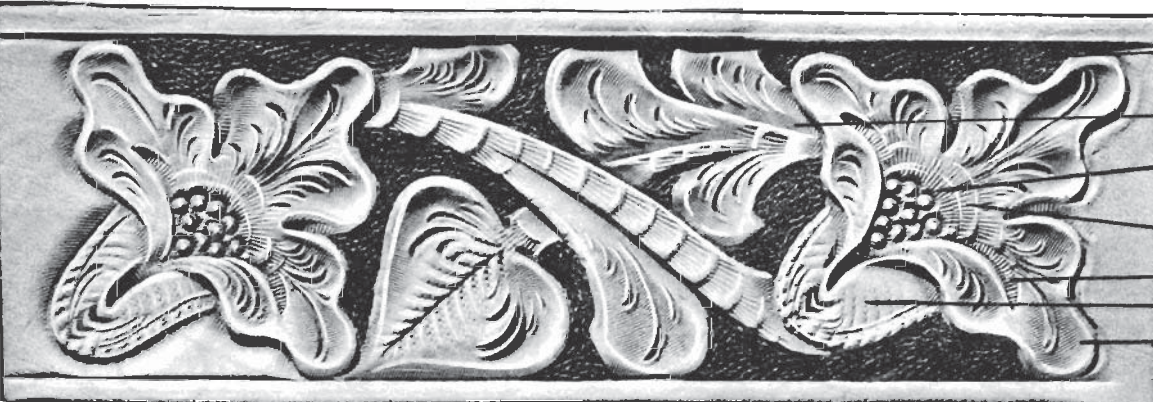
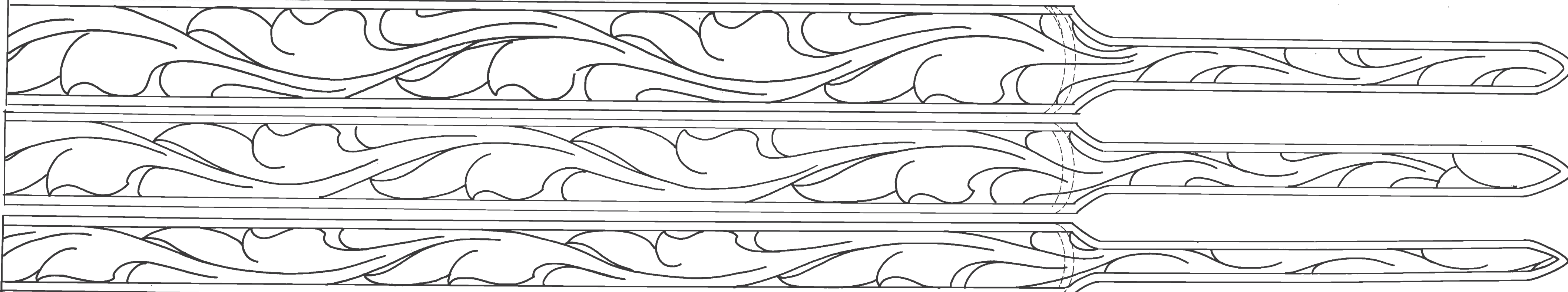

888
205
706
428
707
462
207

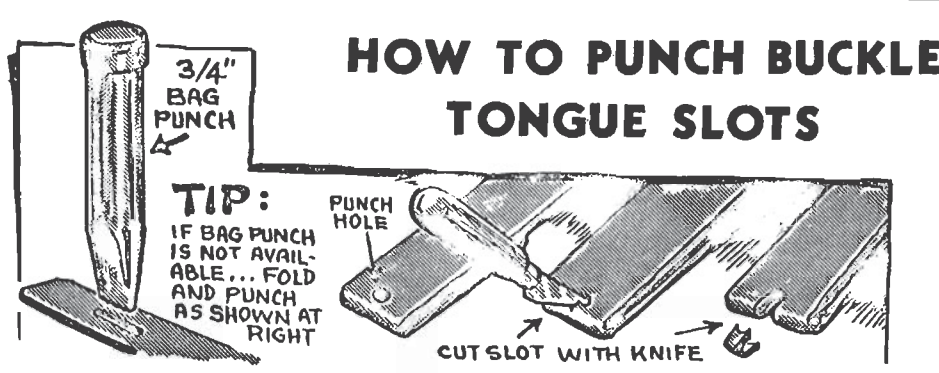

HOW TO PUNCH BUCKLE TONGUE SLOTS

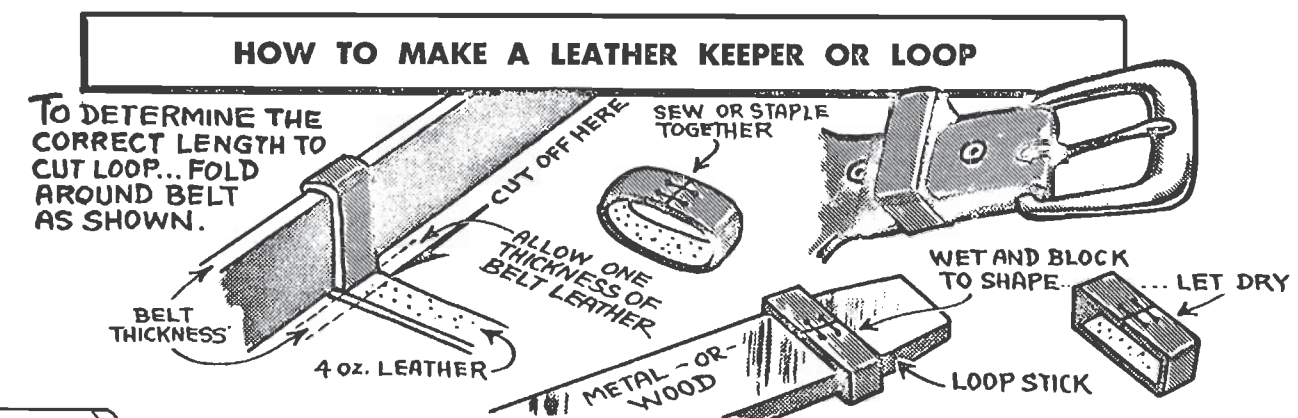

HOW TO MAKE A LEATHER KEEPER OR LOOP

TO DETERMINE THE CORRECT LENGTH TO CUT LOOP... FOLD AROUND BELT AS SHOWN.

CUT OFF HERE
SEW OR STAPLE TOGETHER
WET AND BLOCK TO SHAPE... LET DRY
4 oz. LEATHER
METAL OR WOOD LOOP STICK

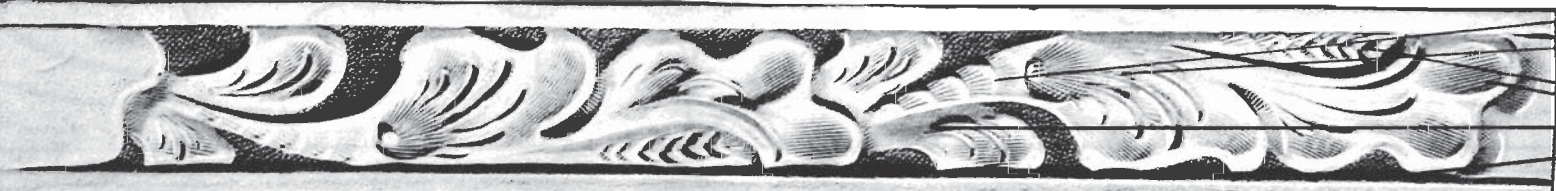

431
364
710
207
198
104

How to measure an old belt to obtain the proper waist size.

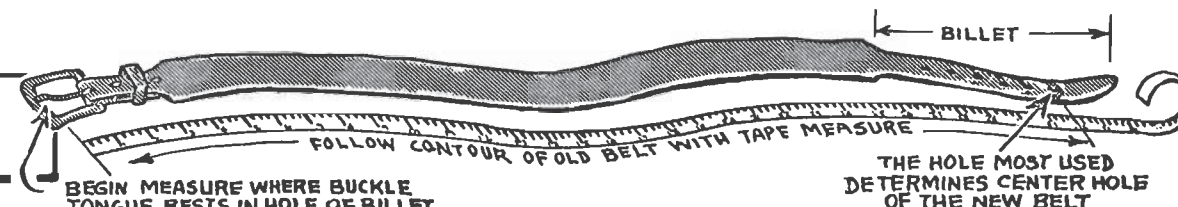

© Copyright 2010 by Tandy Leather Factory All Rights Reserved

NO. 54 BELT PATTERNS

Tandycraft

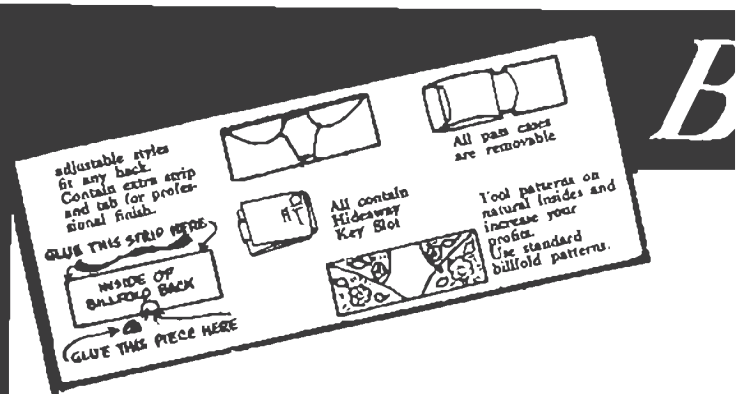

FOR MORE FINE ACC LATEST

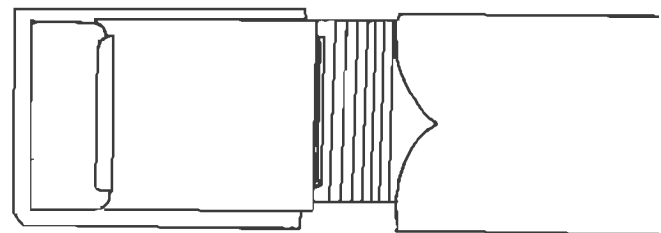

DIPLOMAT

Elegant, finest quality calfskin; die-machine stitched, securely glued. Adjustable; fits any size billfold back. 4 leaf pass case, brass metal tab. Creased center. smooth flat fold. Colors: Black, brown or natural.

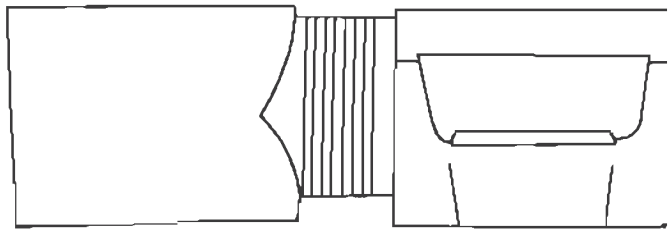

BANKER

Beautiful, finest quality calfskin, superb

Billfold Insides

Quality popular style liners fit for your finest billfolds. Professionally finished, superbly tailored. Die-cut Grade A leathers, machine stitched, securely glued. Complete ready to lace to back.

ACCESSORIES, CHECK TANDY'S
CATALOG!

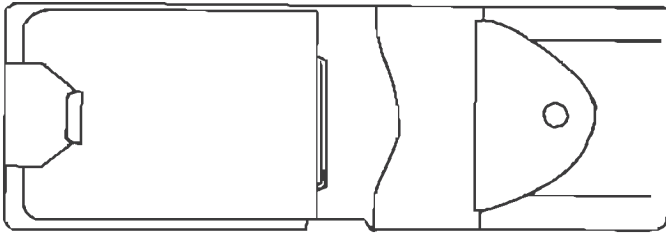

TRADER Quality calfskin, precision cut. Machine stitched, securely glued. Non-adjustable size 8 7/8" x 3 1/8". Pleated coin purse expands to hold plenty of change. Removable 4 leaf pass case. Brass tab. Colors: 2 tone brown and natural, brown, natural and black.

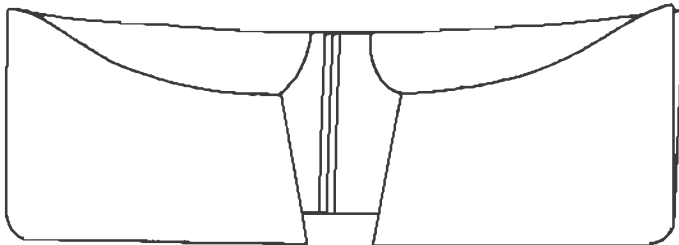

EXECUTIVE Popular executive style billfold. Die cut from Grade A calfskins. Machine stitched, securely glued.

It's
New-
tail

SEND
CR
ESPECIA
FOR I
ORGA

ndycraft!

**FOR THESE
AFTAIDS
ALLY DESIGNED
FRATERNAL
ANIZATIONS**



**“WRITE FOR LATEST
CATALOG PRICE LIST”
WRITE DEPT. A.**

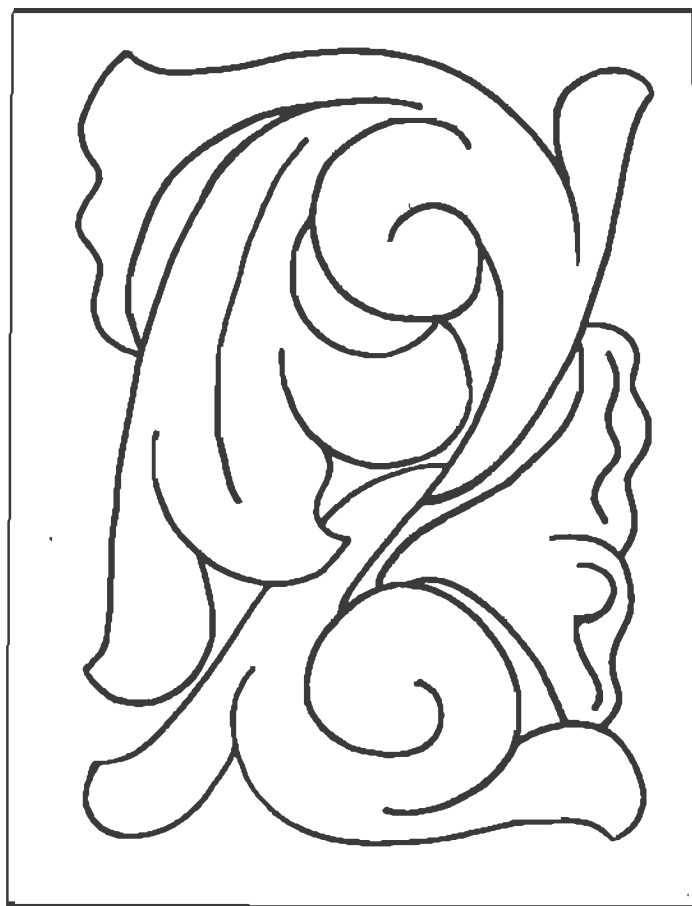

tailored. Die-cut Grade A leather, machi
stitched, securely glued. Adjustable siz
fits any billfold back. Expansion co
purse, brass metal tabs. Center crease f
smooth flat fold. Colors: Black, brow
natural.

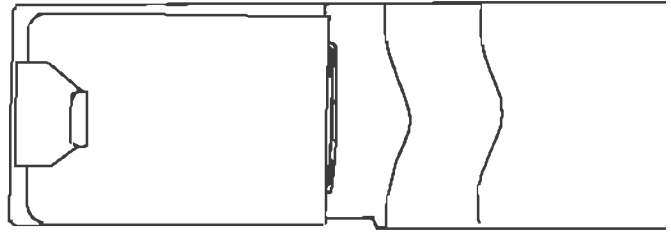

MERCHANT

Quality calfskin, precision cut. Machin
stitched. Non-adjustable size 9" x 3 1/8"
Three pockets and removable 4 leaf pa
case. Brass tabs. Colors: 2 tone brown an
natural, natural, brown and black.

(No part of this or any other page

How to

NAME

1 1/2 IN



come stitched, securely glued. Words "cards" and "passes" stamped in leather. Feature extra strip and tab to cement inside billfold back for finest professional finish. Colors: 1-A Black; 1-B Brown; 1-C Natural; 1-D Two tone black and natural; 1-E Two tone brown and natural.

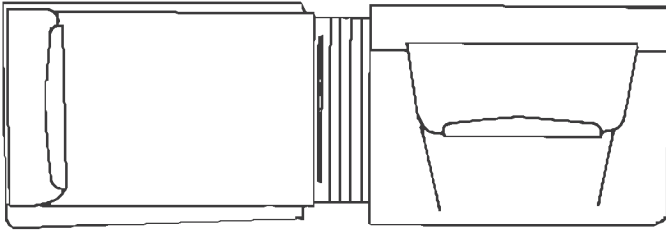

COSMOPOLITAN Billfold Inside
 Combines best features of popular style billfolds. Beautiful tooling calf can be carved to match billfold back. Expansion coin purse; folding removable card case; 2 wing inserts. Extra pocket inside card case. Metal tabs attached; soap set. Fits any size billfold back. Colors: Natural, Black, Brown.

may be reproduced without written permission.)

find Center
or
BELTS



PRINTED IN U. S. A.





Fandy

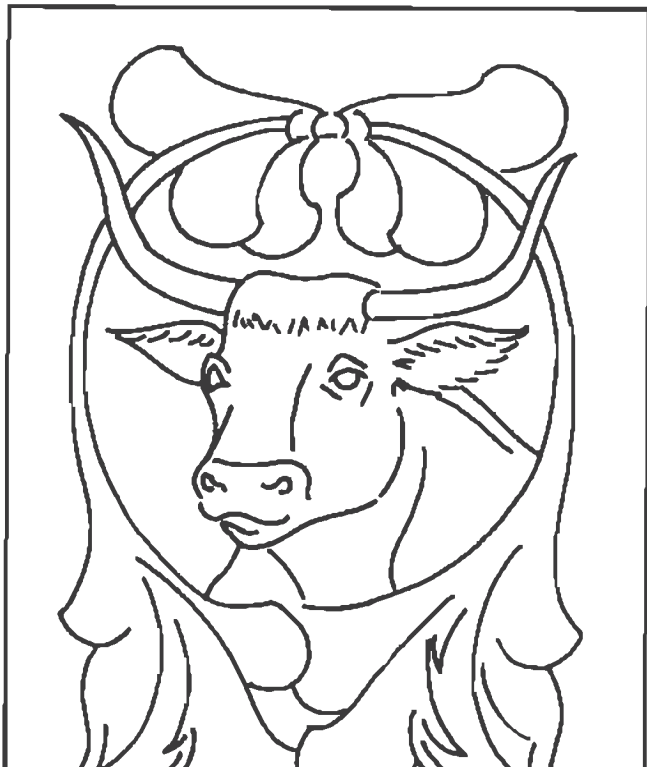
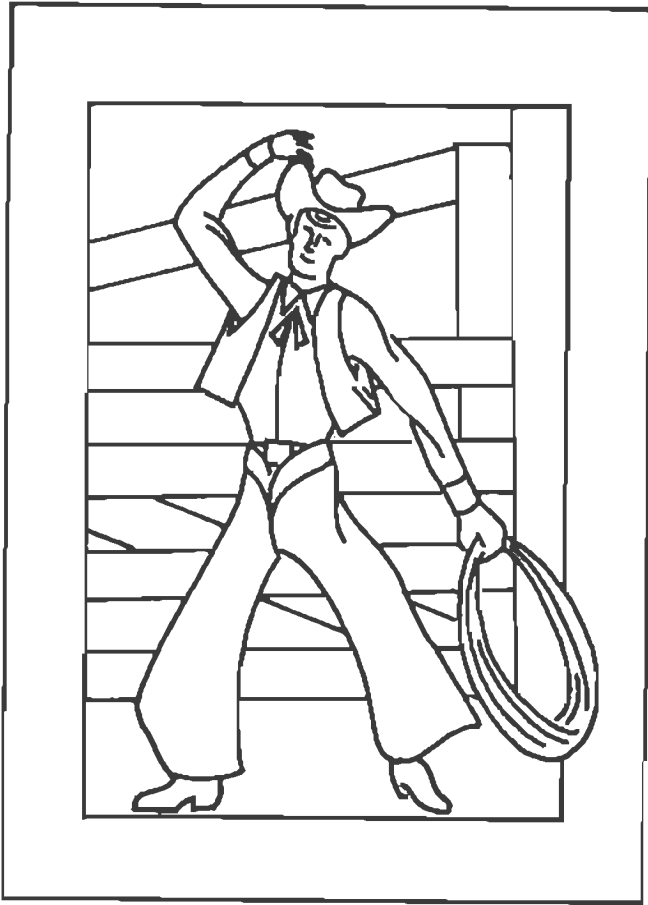

© Copyright 2010 by Tandy Leather Factory
All Rights Reserved

J.54 BELT PATTERNS

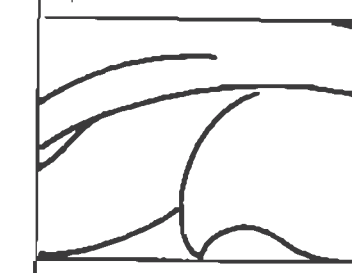
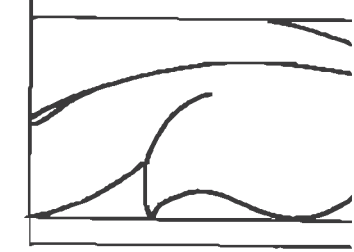
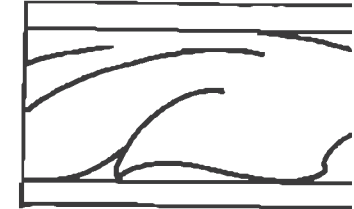
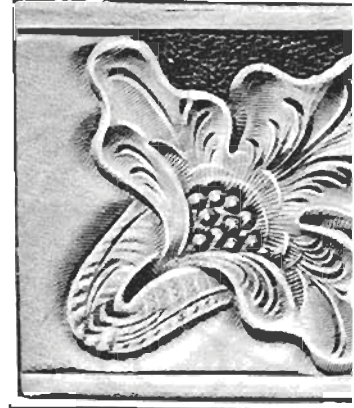

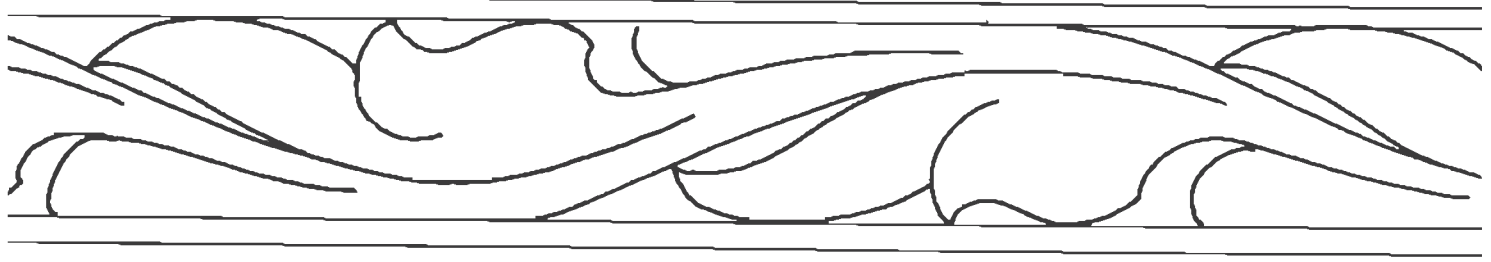
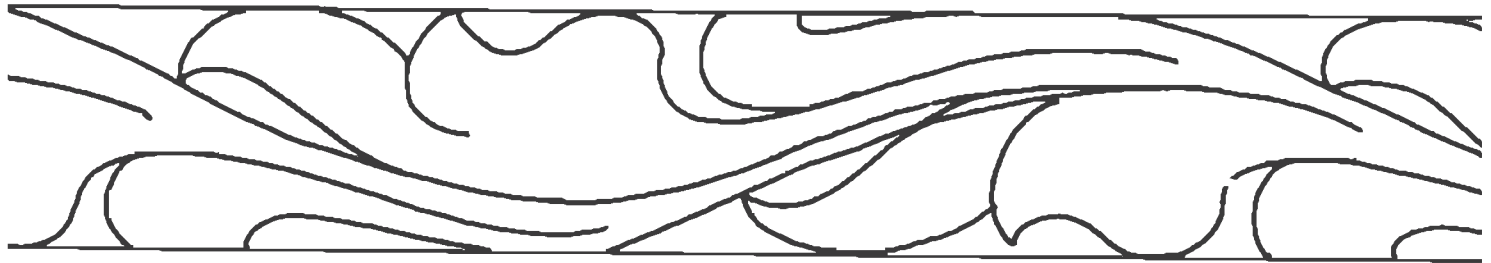

- 888
- 206
- 706
- 426
- 707
- 462
- 207

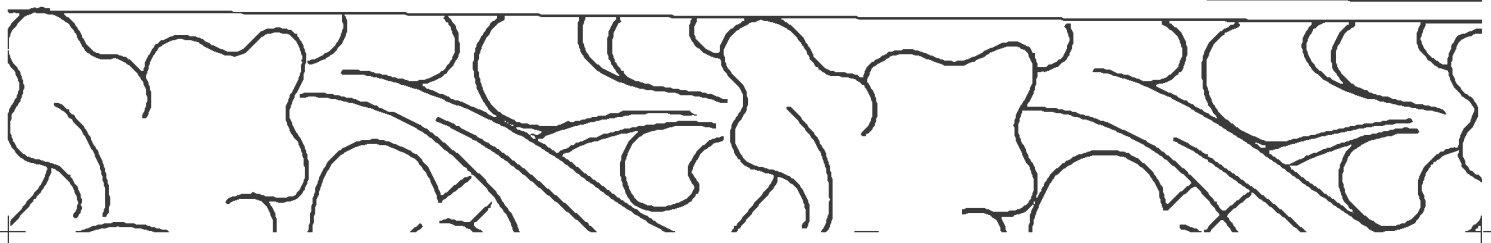
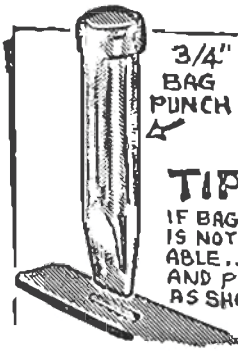

- 888
- 857
- 708
- 971
- 222



HOW TO PUNCH BUCKLE TONGUE SLOTS

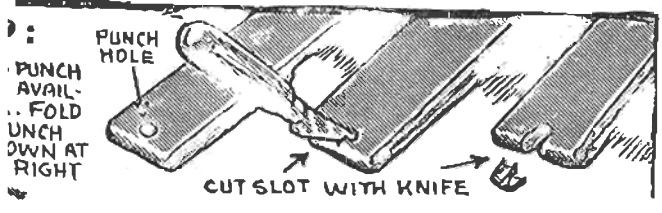

HOW TO MAKE A

TO DETERMINE THE CORRECT LENGTH TO CUT LOOP... FOLD AROUND BELT AS SHOWN.

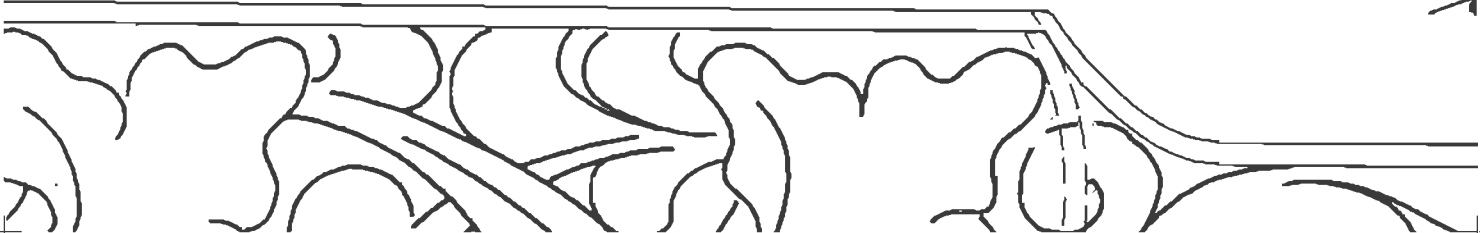
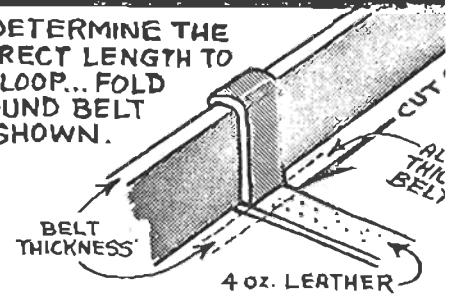

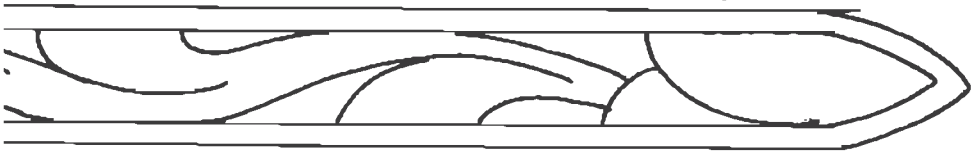
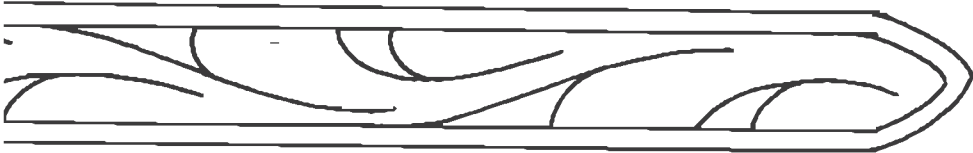

LEATHER KEEPER OR LOOP

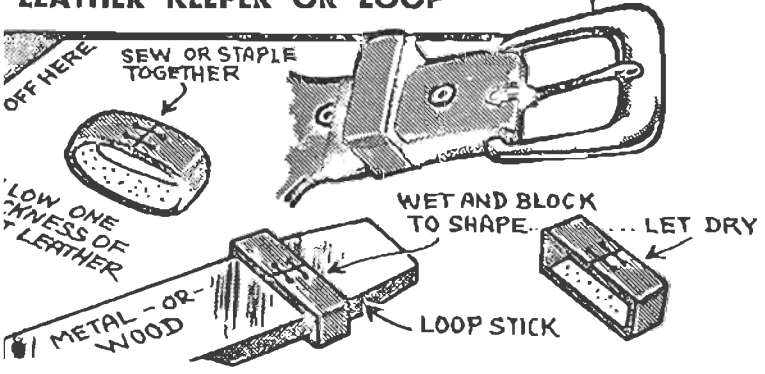

tandycraft

NE

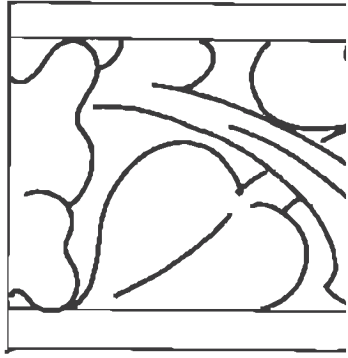
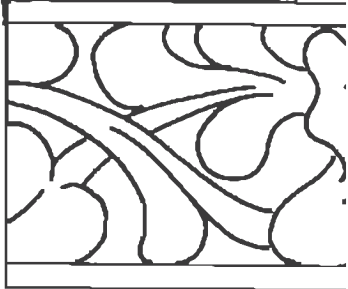
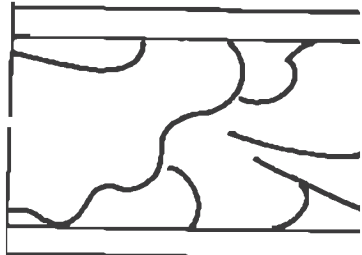
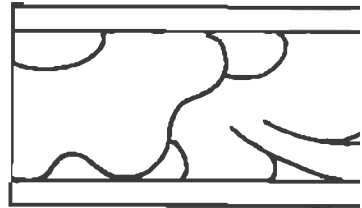

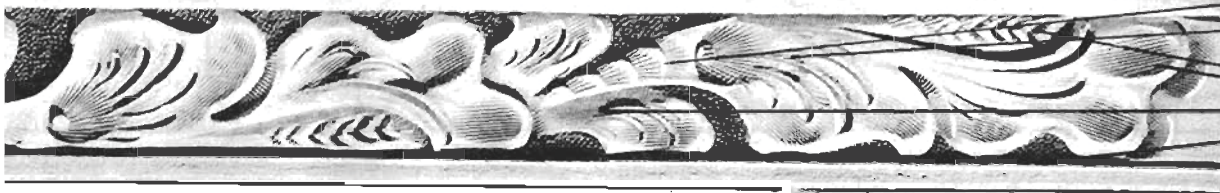
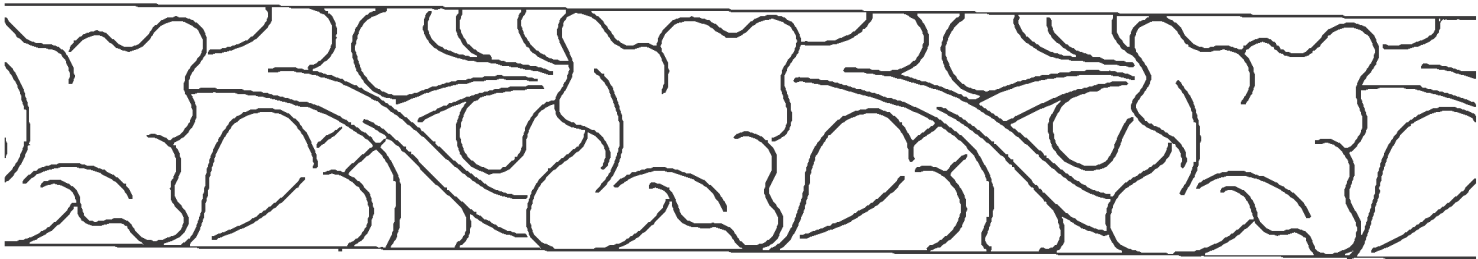
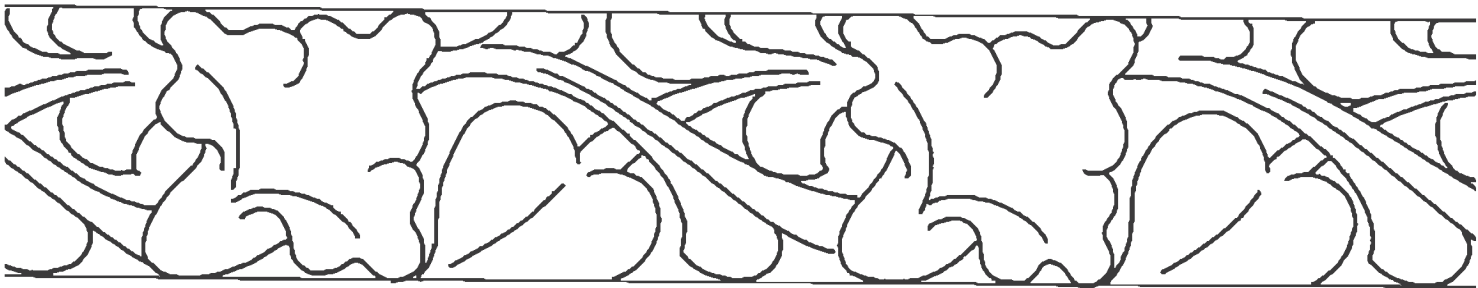

- 431
- 364
- 710
- 207
- 198
- 104

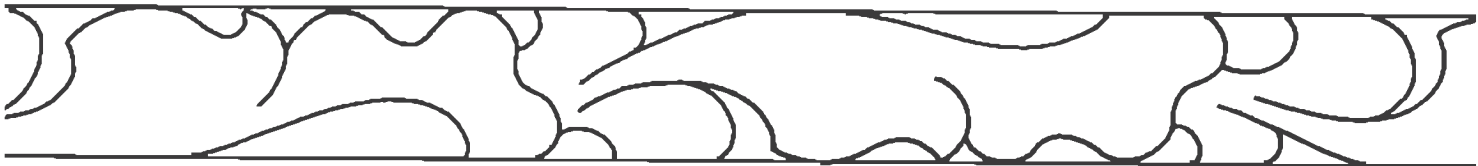
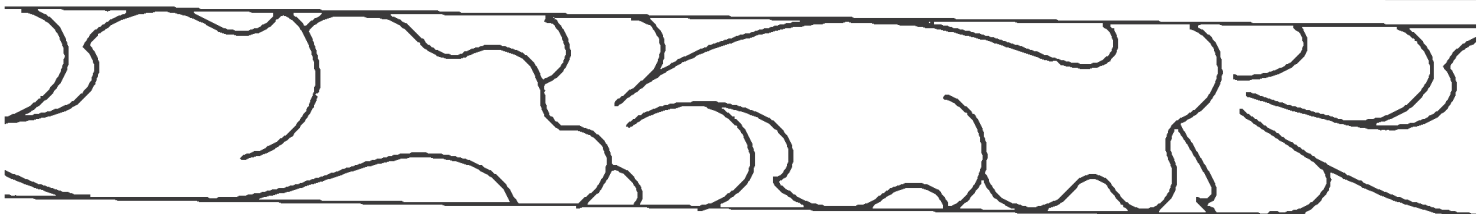

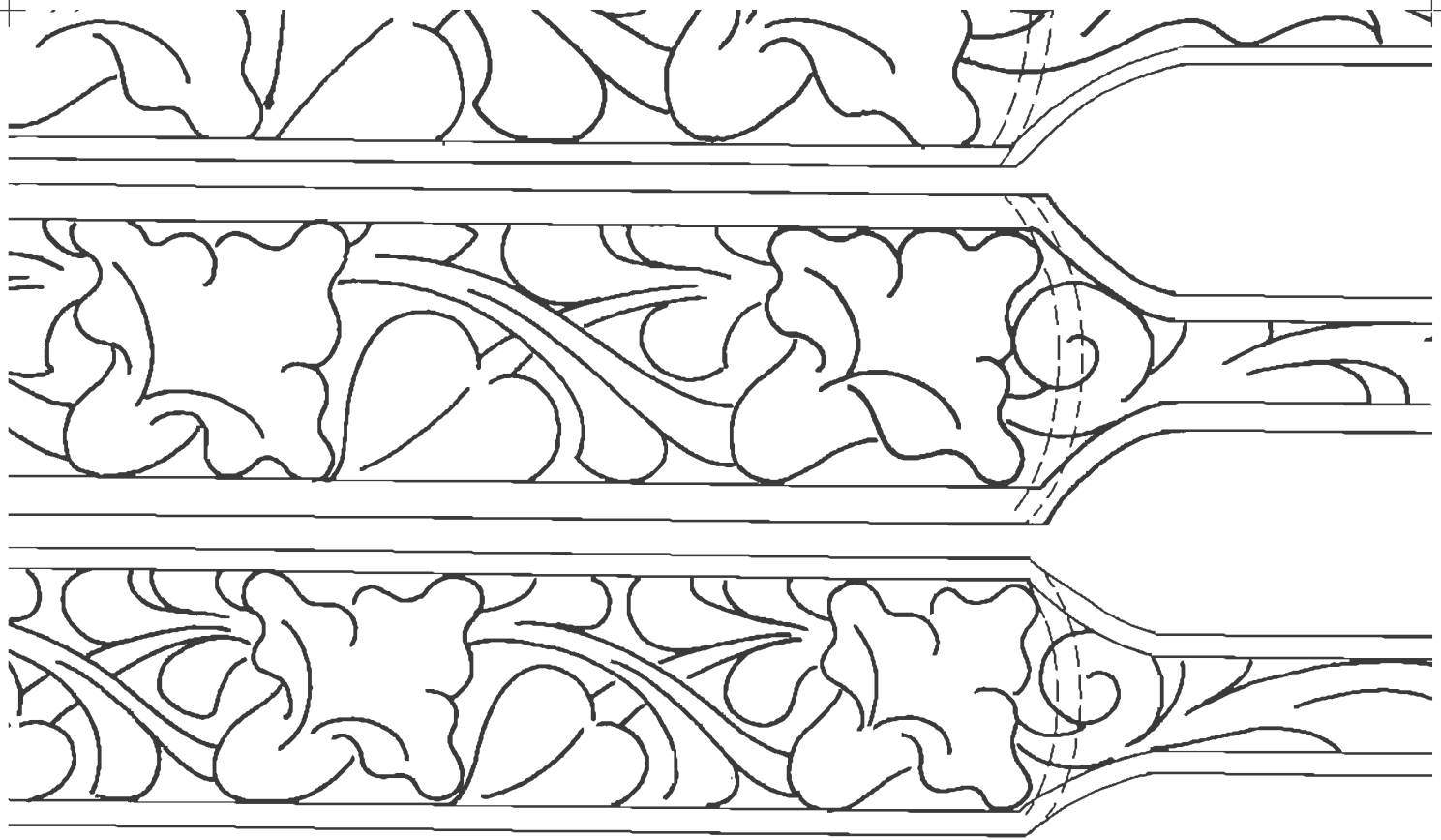

How to measure an old belt to obtain the proper waist size.

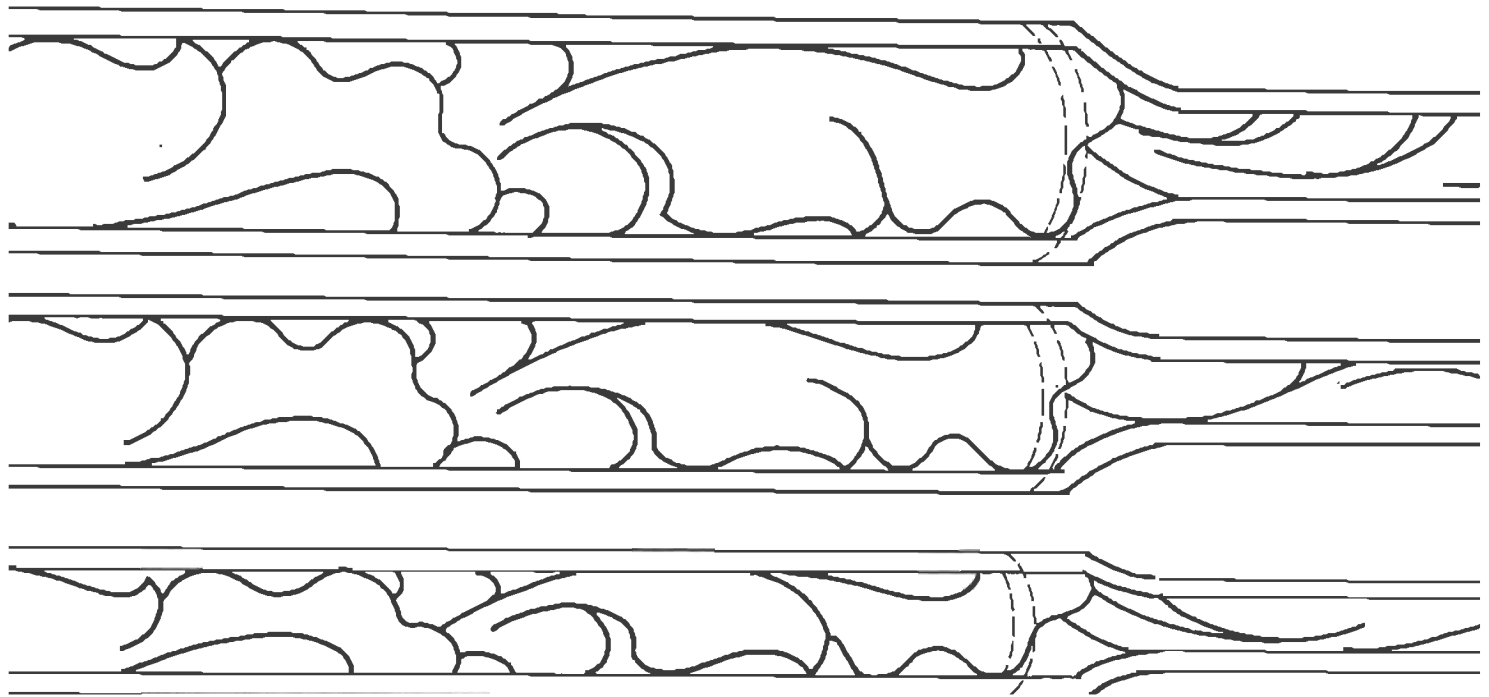
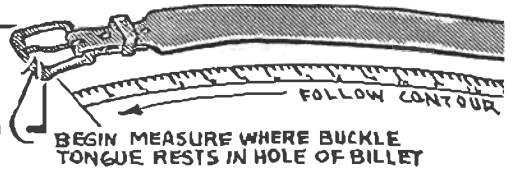

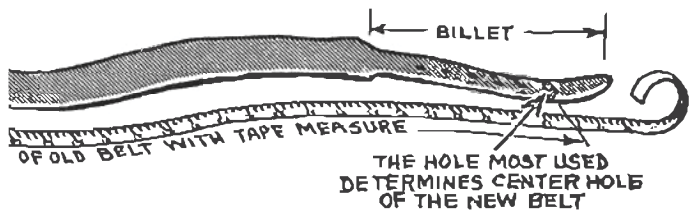
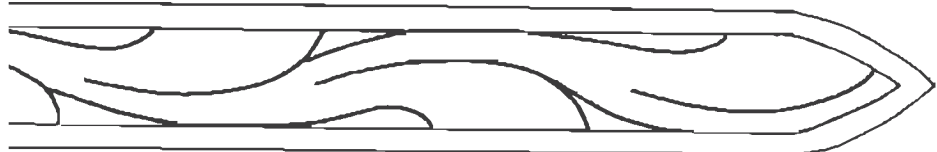

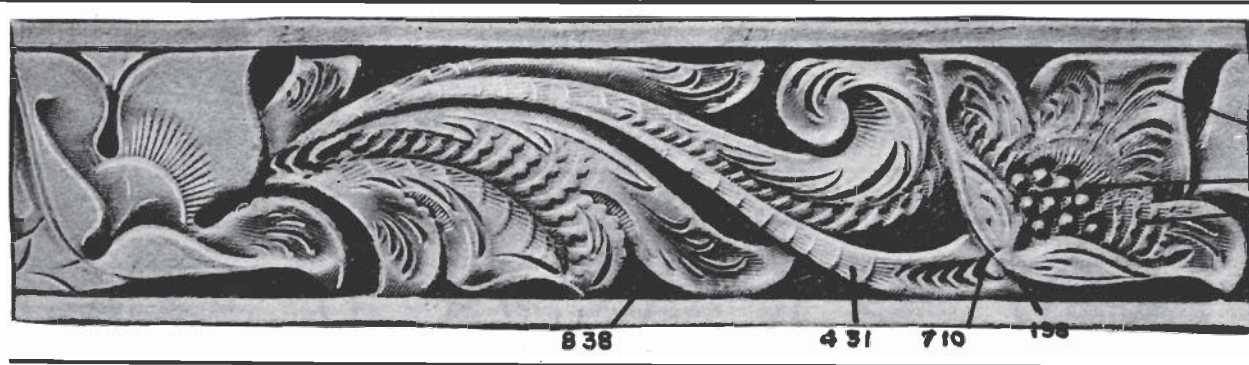
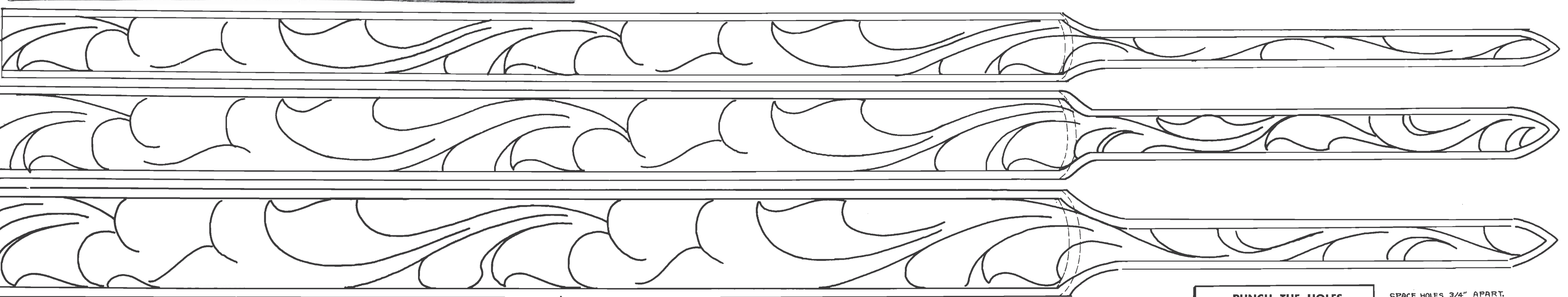
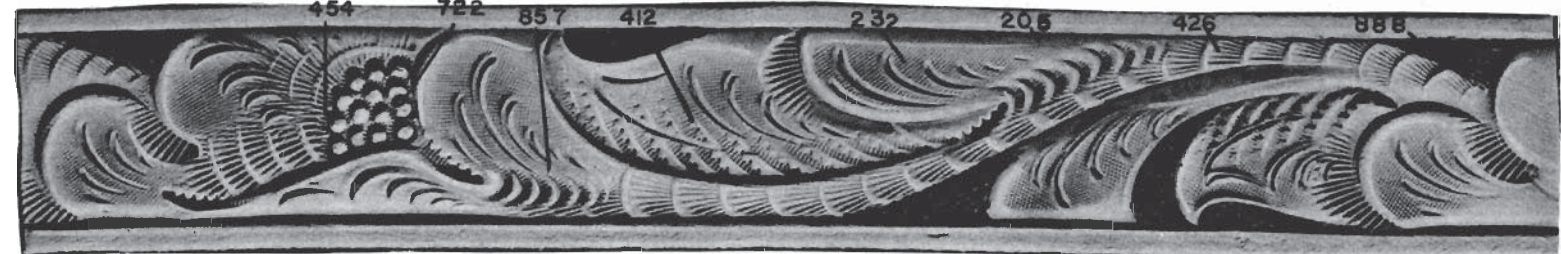

1ST IN IMPORTANCE is the **WAIST SIZE!**
Measure around the waist and pull the tape snug, but not too tight. This is the correct waist size.

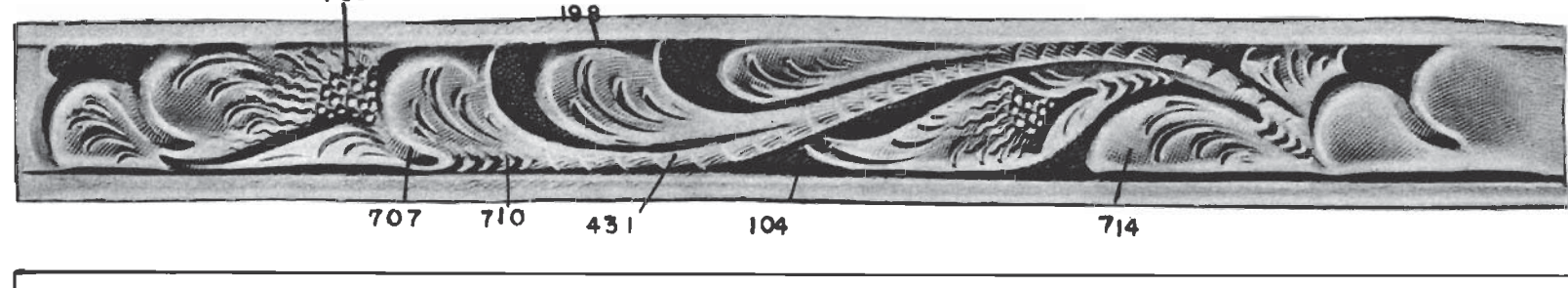
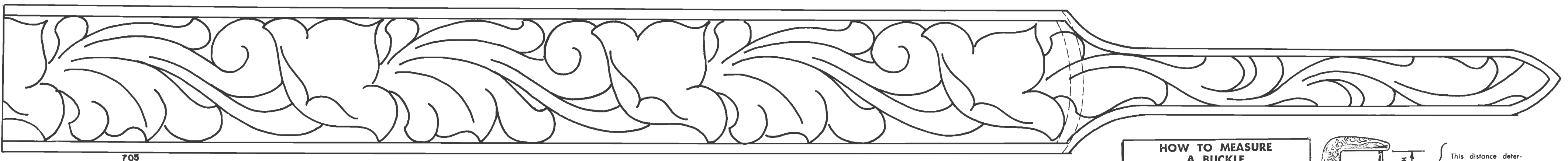
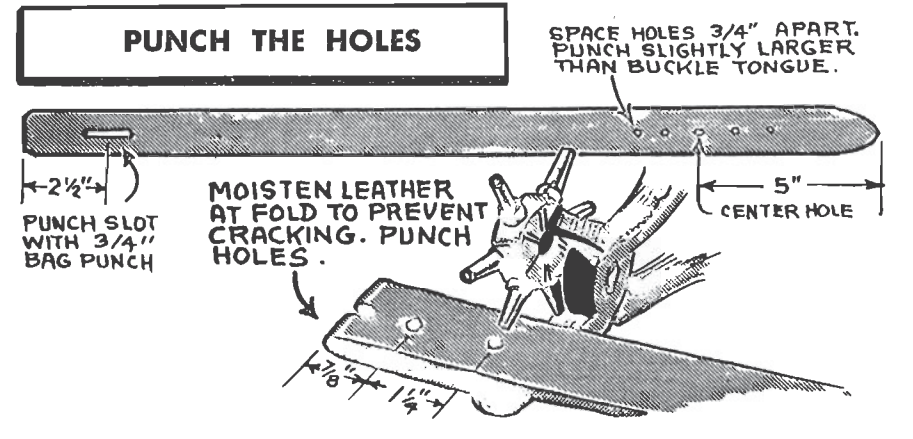
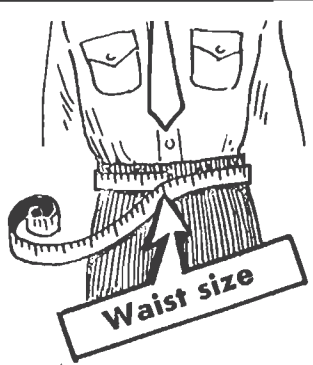

2ND IN IMPORTANCE is the **BUCKLE SIZE!**
Though shapes and sizes may vary, there are basically two common types of buckles, the bar buckle and the hook buckle.

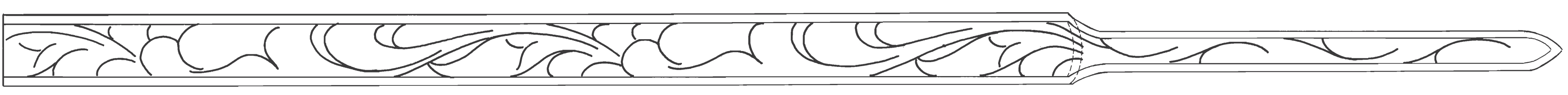
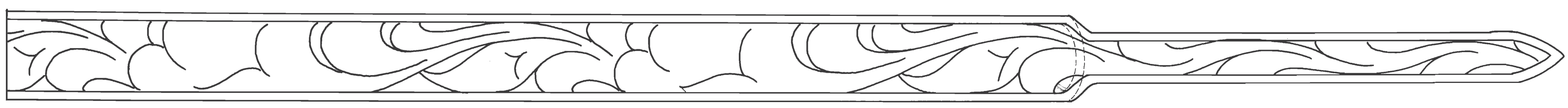
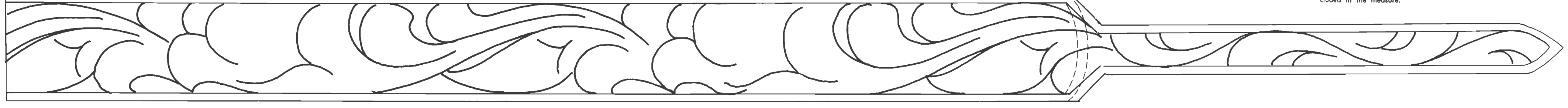
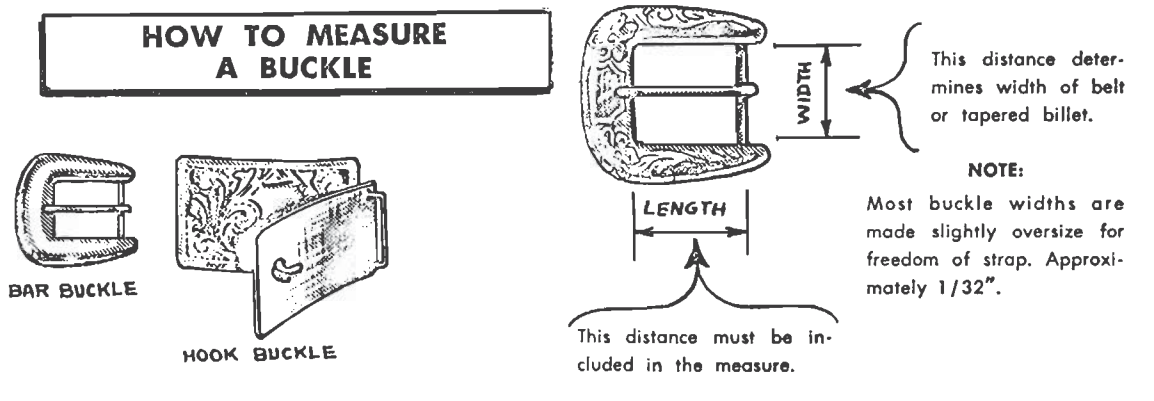

© Copyright 2010 by Tandy Leather Factory
All Rights Reserved

1 1/4-INCH LETTERS FOR 1 1/2-INCH TROPHY BELTS



1-INCH LETTERS FOR 1 1/4-INCH BELTS

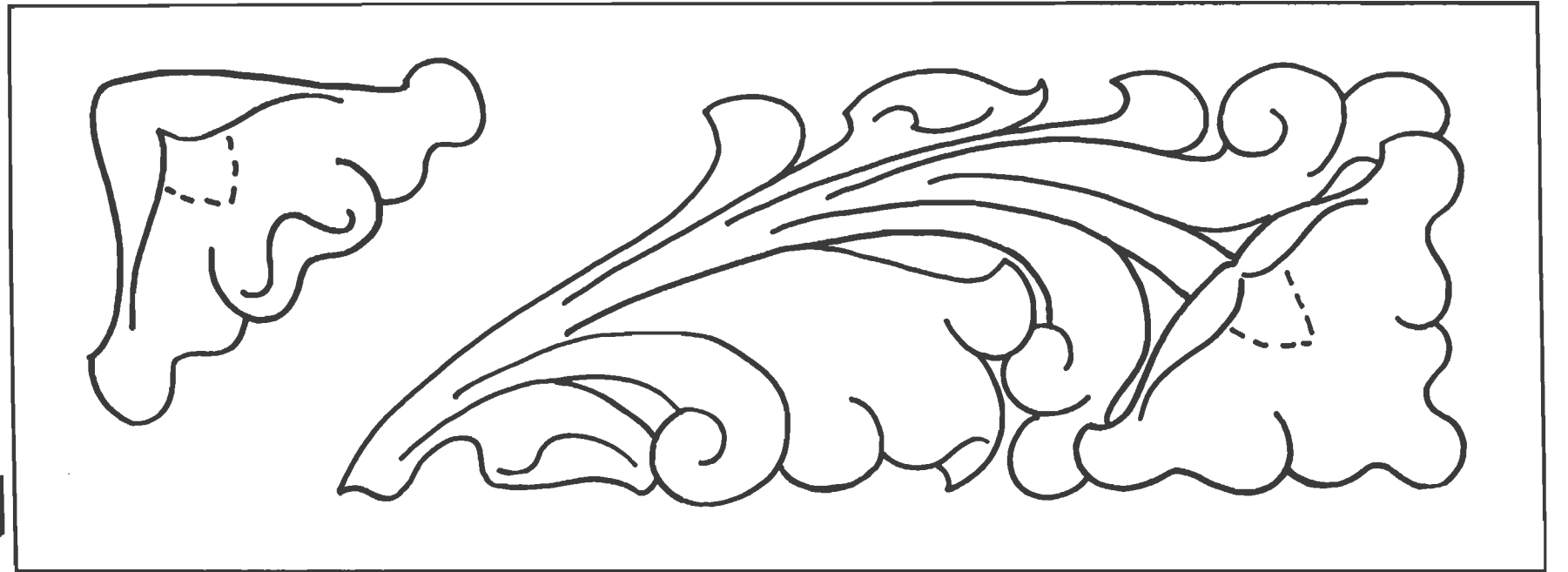
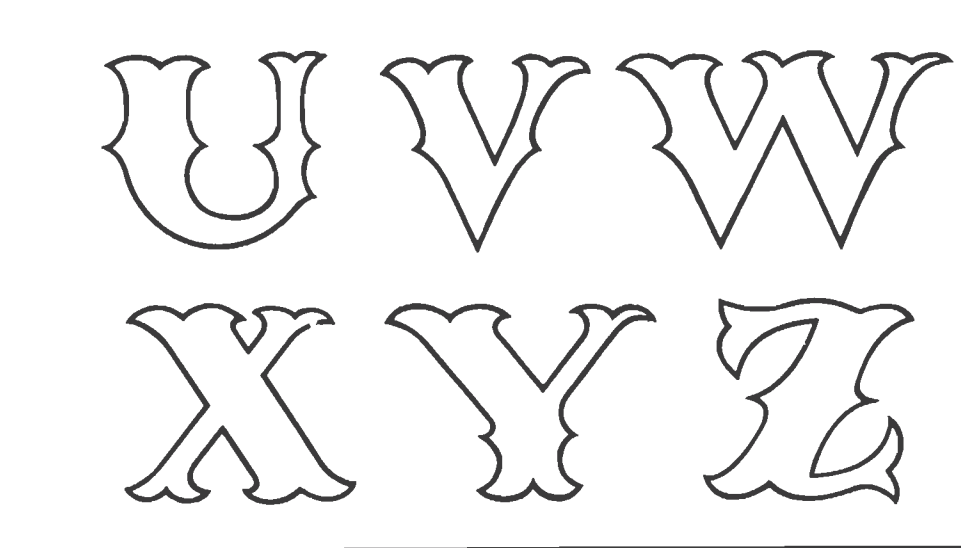
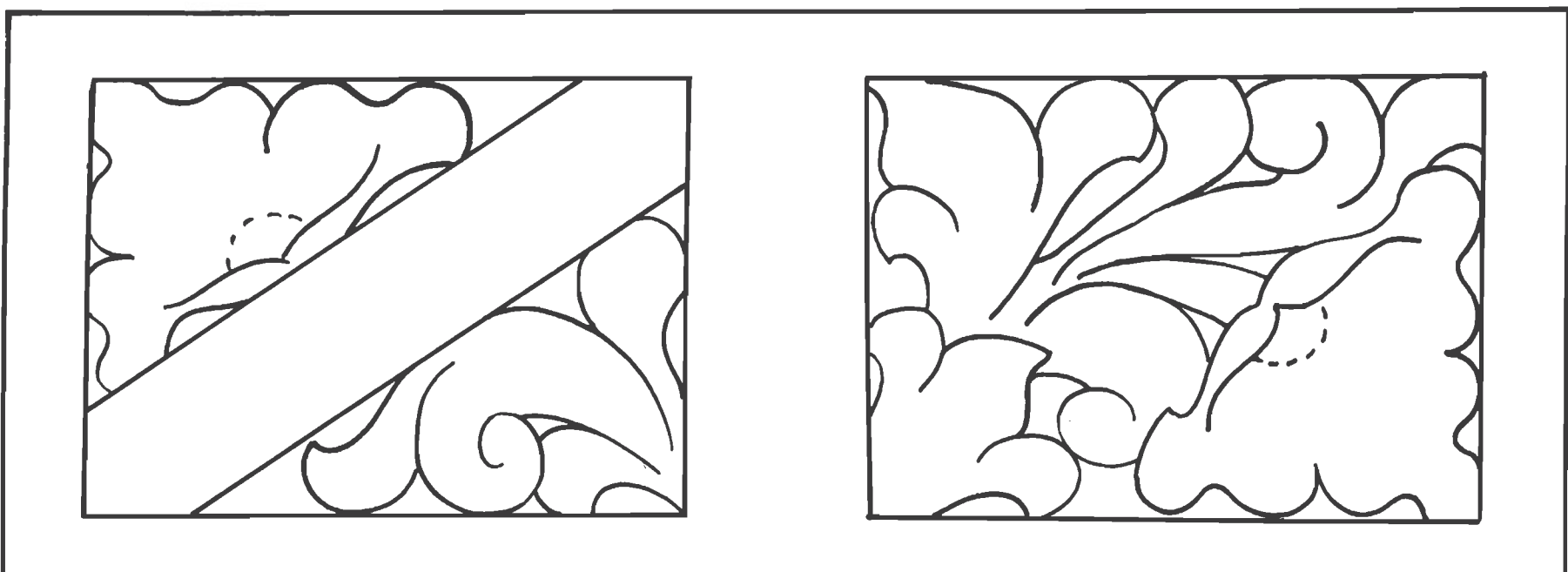
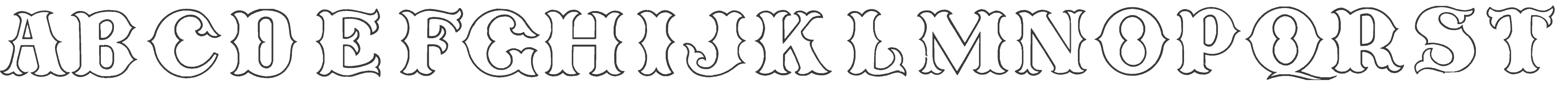

NEW "ALPHABET" CRAFTTOOLS

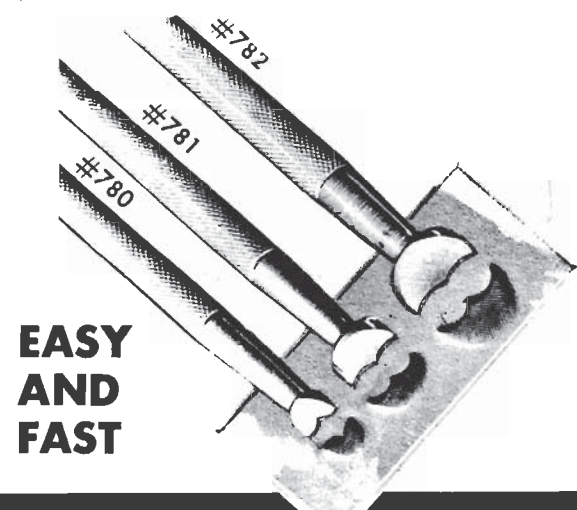

CARVE LETTERS WITHOUT A SWIVEL KNIFE

NOW add name or initials to your leatherwork easily, quickly WITHOUT TEDIOUS SWIVEL KNIFE CUTTING. Just trace, stamp with new alphabet crafttools and bevel. Easy and fast to add new value, bring new profits from your leatherwork. Personalize every piece with the aid of New Alphabet Crafttools. **SAVE** Order the set of **THREE TODAY!** Start **NOW** to plan your personalized Christmas projects for gifts or profit!

CRAFTED 3207 New alphabet of 2" letters especially designed for Alphabet Crafttools.



3/4-INCH LETTERS FOR 1-INCH BELTS



1/2-INCH LETTERS FOR BILLFOLDS, ETC.



HOW TO SET SNAPS

- Check four parts of snap as shown below. The button and socket form one unit, stud and eyelet the other. Both Snap and Binding Snaps are set in the same manner.
- Locate and punch a hole of the correct size for socket.
- Place socket over correct anvil of the plate (see chart below). Push leather down over socket, gain side up. Then put button on the socket.
- Place the large concave punch on top of button. Strike punch with mallet, thus setting the button and socket.
- Locate and punch hole of correct size for eyelet.
- Place eyelet over small anvil in the center of plate, then put leather over the eyelet and the stud over eyelet and leather. Check to see that it's not backwards.
- Choose proper punch (see chart) over stud. Strike punch with mallet, thus setting stud and eyelet.

SOCKET **STUD** **EYELET** **EYELET** **STUD** **SOCKET**

ASSEMBLING INSTRUCTIONS FOR BILLFOLDS

- See Tooling Instructions.
- After you have tooled the billfold back and the inside decorative corners, you should cement the parts together and let them set till the cement is well set.
- It is in billfolds that you can get the best selling power of leather dyes. Women use a lot of color. Dye the billfold before you lace it. When using NEAT-LAC and dye on the same article here are the rules to remember: A. When the background is to be dyed, you apply the NEAT-LAC first and then dye the leather. B. When other parts of leather are to be dyed you dye first and then NEAT-LAC. Example: If you had a billfold and you wanted to dye the flower yellow and the background blue, you would: 1st. Dye the flower yellow. 2nd. Apply NEAT-LAC all over. 3rd. Apply blue background dye.
- In lacing all the parts together, be sure that the edges are even. Always tighten the lacing as you go.
- When you are finished lacing, and have glued the ends in and have trimmed the pieces, you should dampen the lacing, and then heat the lacing flat. This will give the lacing the correct finished appearance.
- Put a card in the billfold with your name, address, and telephone number on it. Ask the person who gets the billfold to give the card to the first person who mentions its beauty.

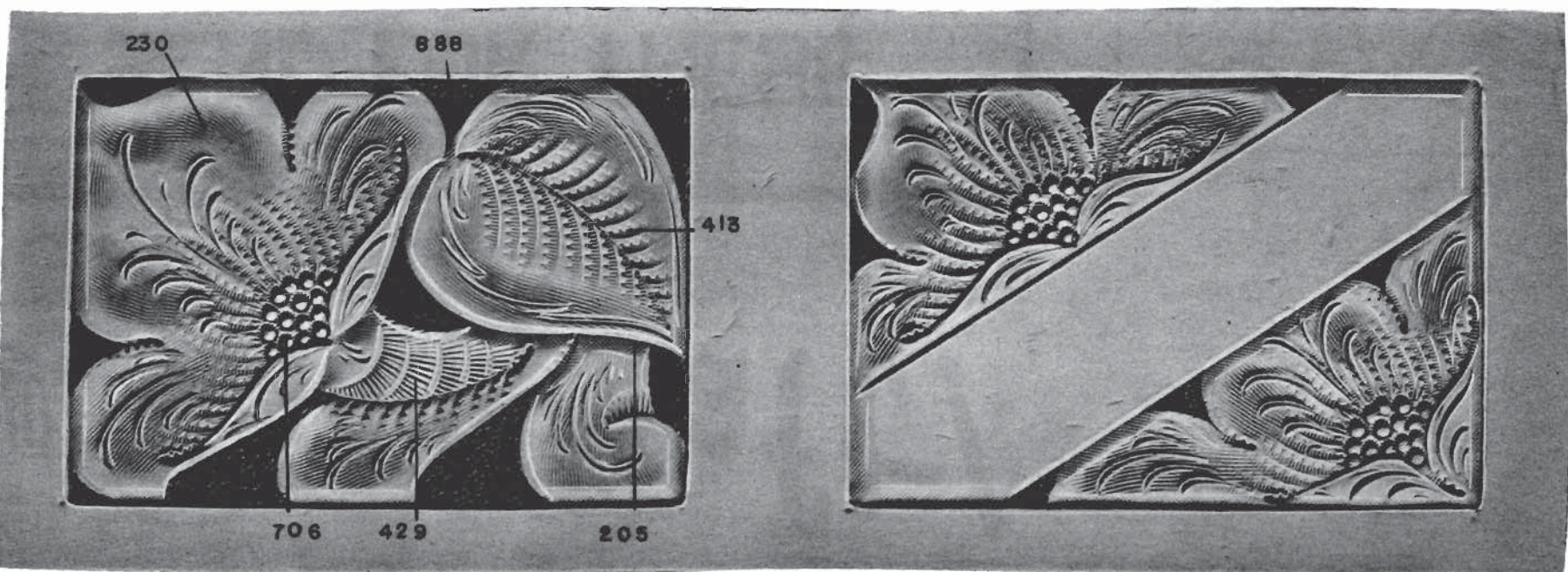
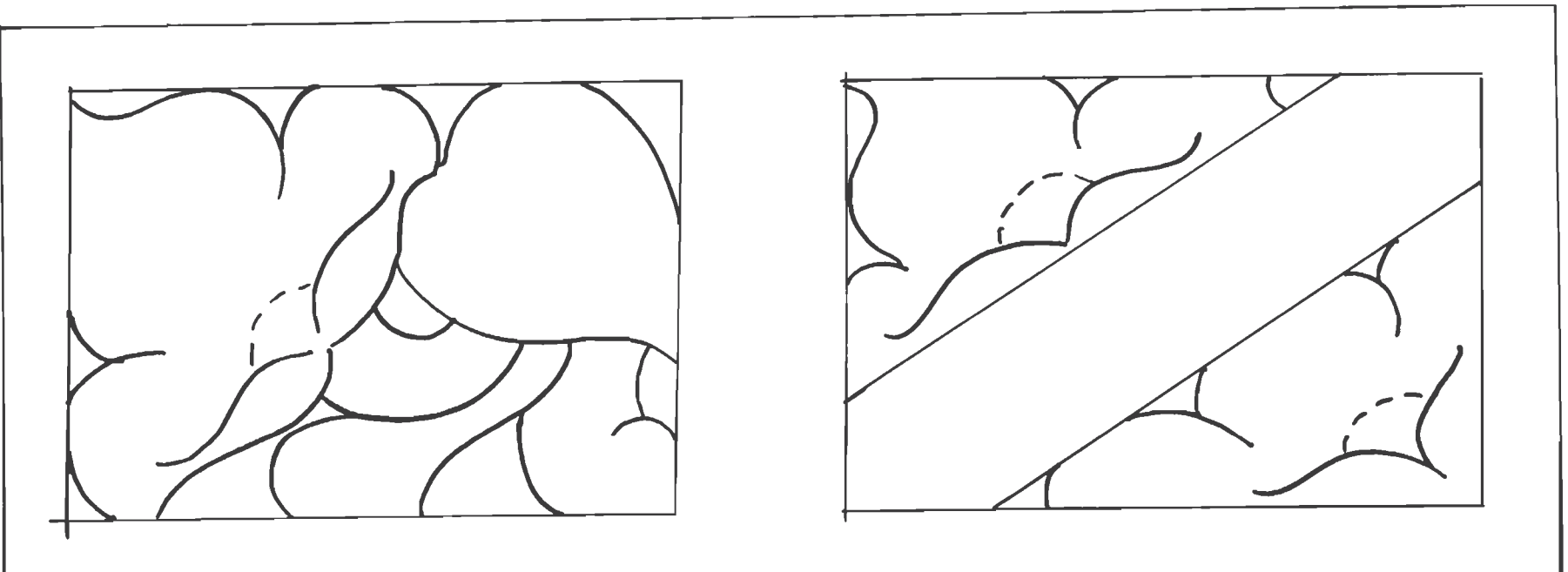
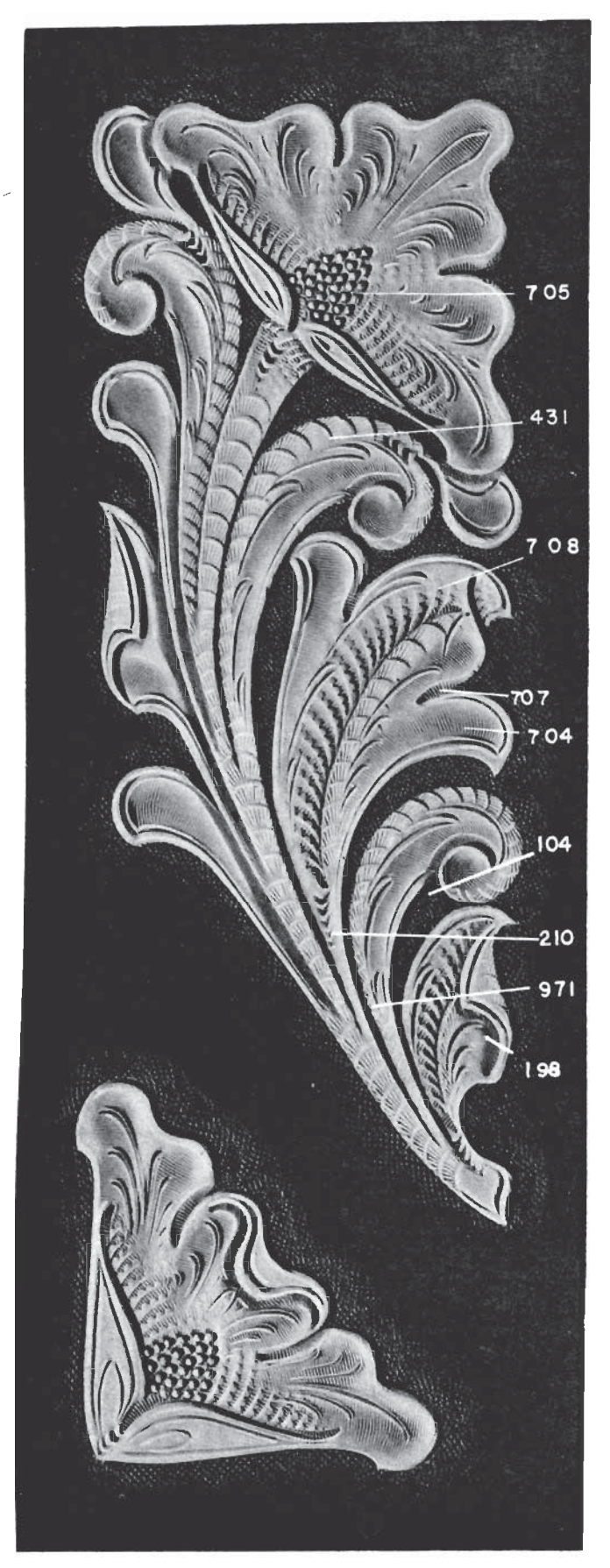

PATTERNS

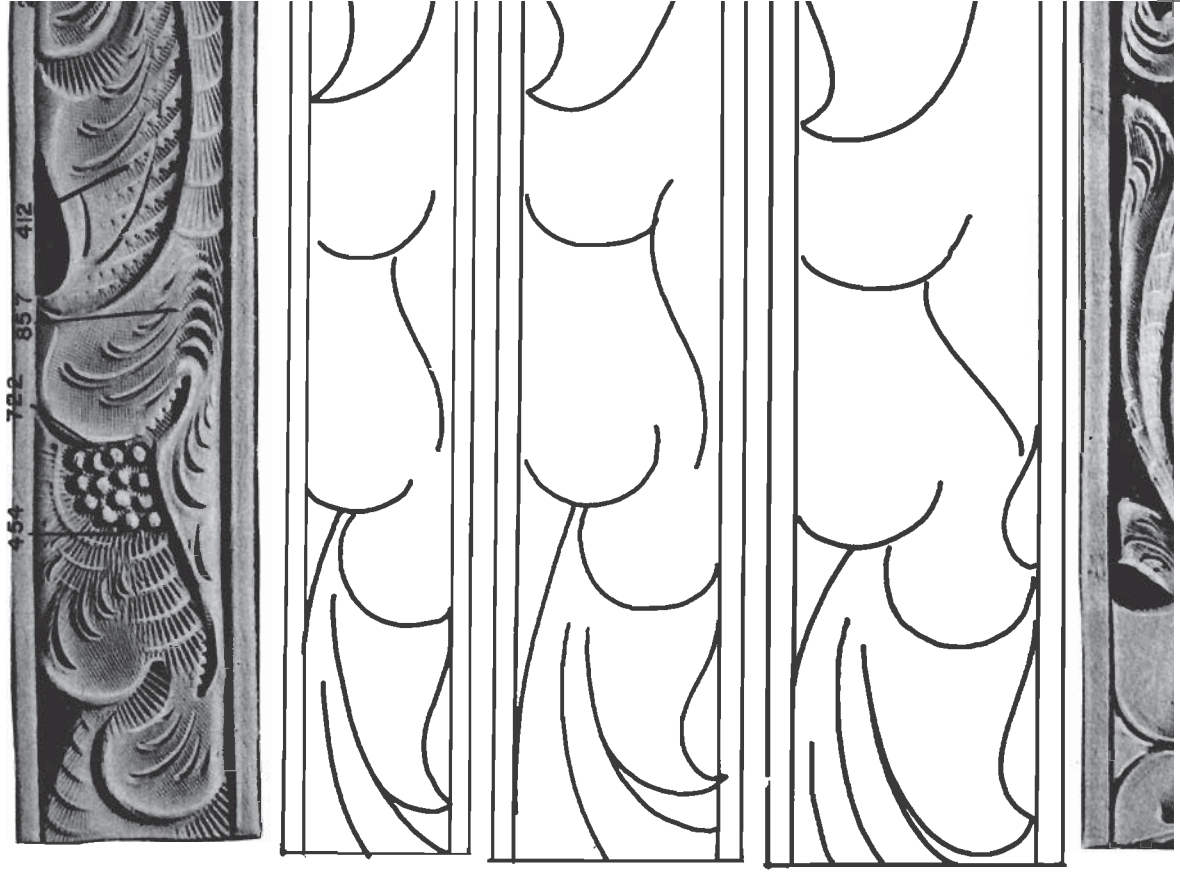

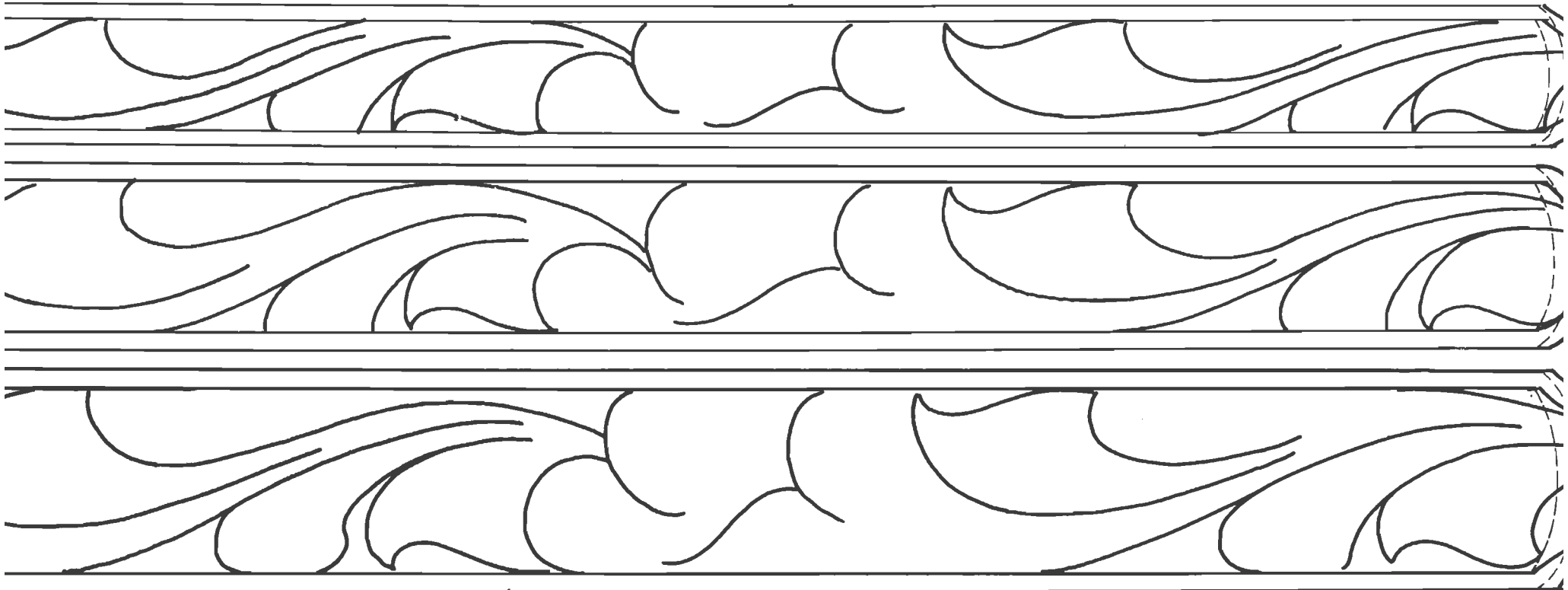
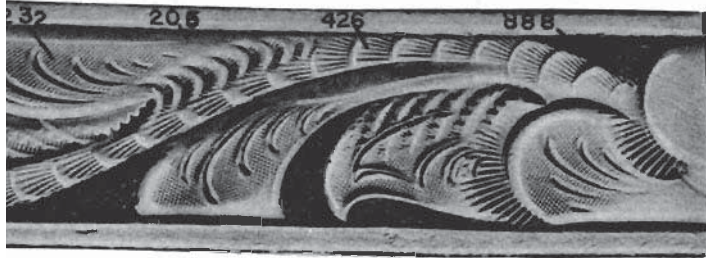

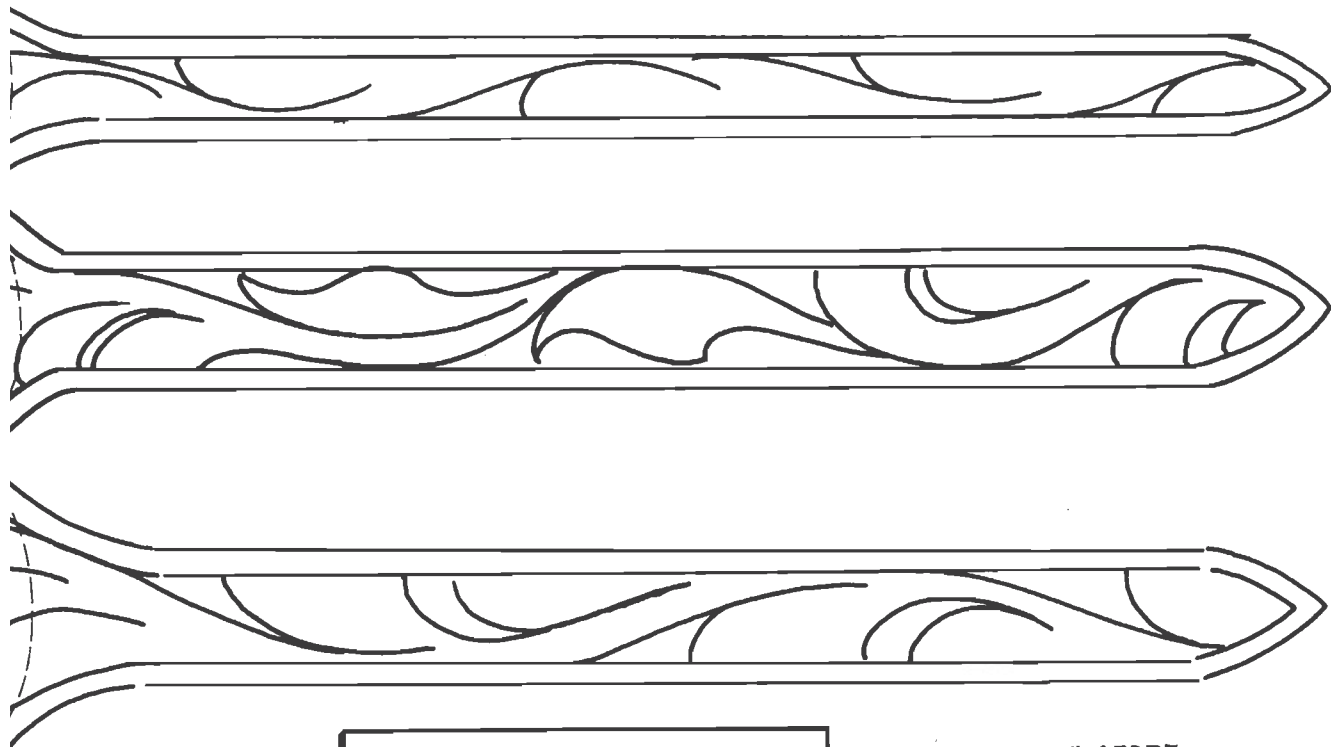

PUNCH THE HOLES

SPACE HOLES 3/4" APART.
PUNCH SLIGHTLY LARGER
THAN BUCKLE TONGUE.



ndycraft

NO. 54 BELT

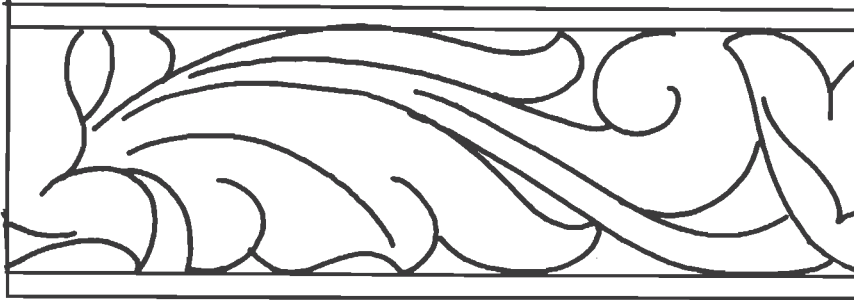
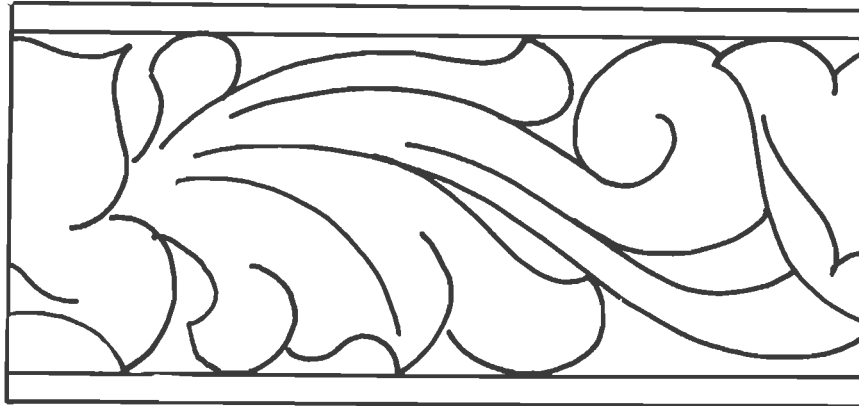
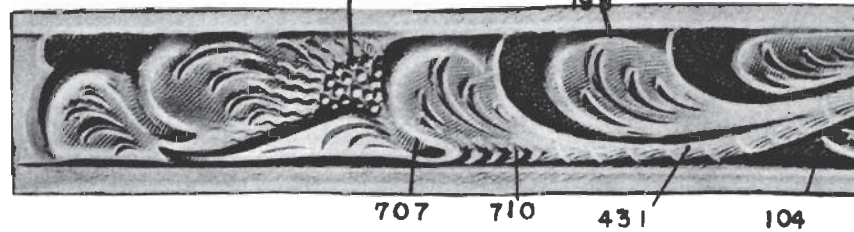



1ST IN IMPORTANC is the **WAIST SIZE!**
Measure around the waist and pull the tape snug, but not too tight. This is the correct waist size.

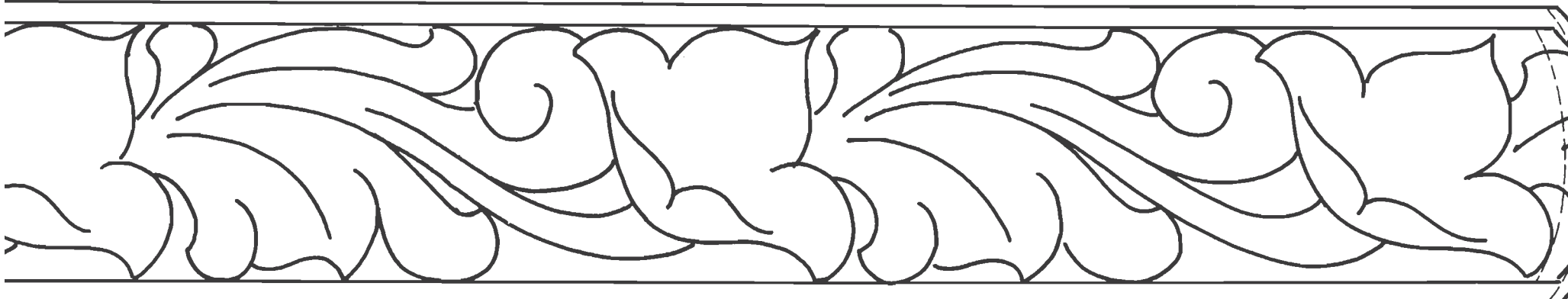
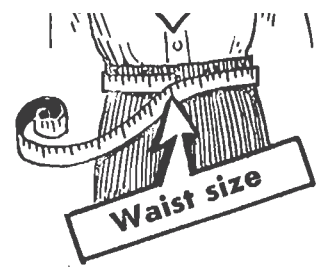

2ND IN IMPORTANC is the buckle size. Though shapes and sizes may vary, there are basically two common types of buckles; the bar buckle and the hoo buckle.

←2½"→
PUNCH SLOT
WITH ¾" BAG PUNCH

MOISTEN LEATHER
AT FOLD TO PREVENT
CRACKING. PUNCH
HOLES.

5"
CENTER HOLE

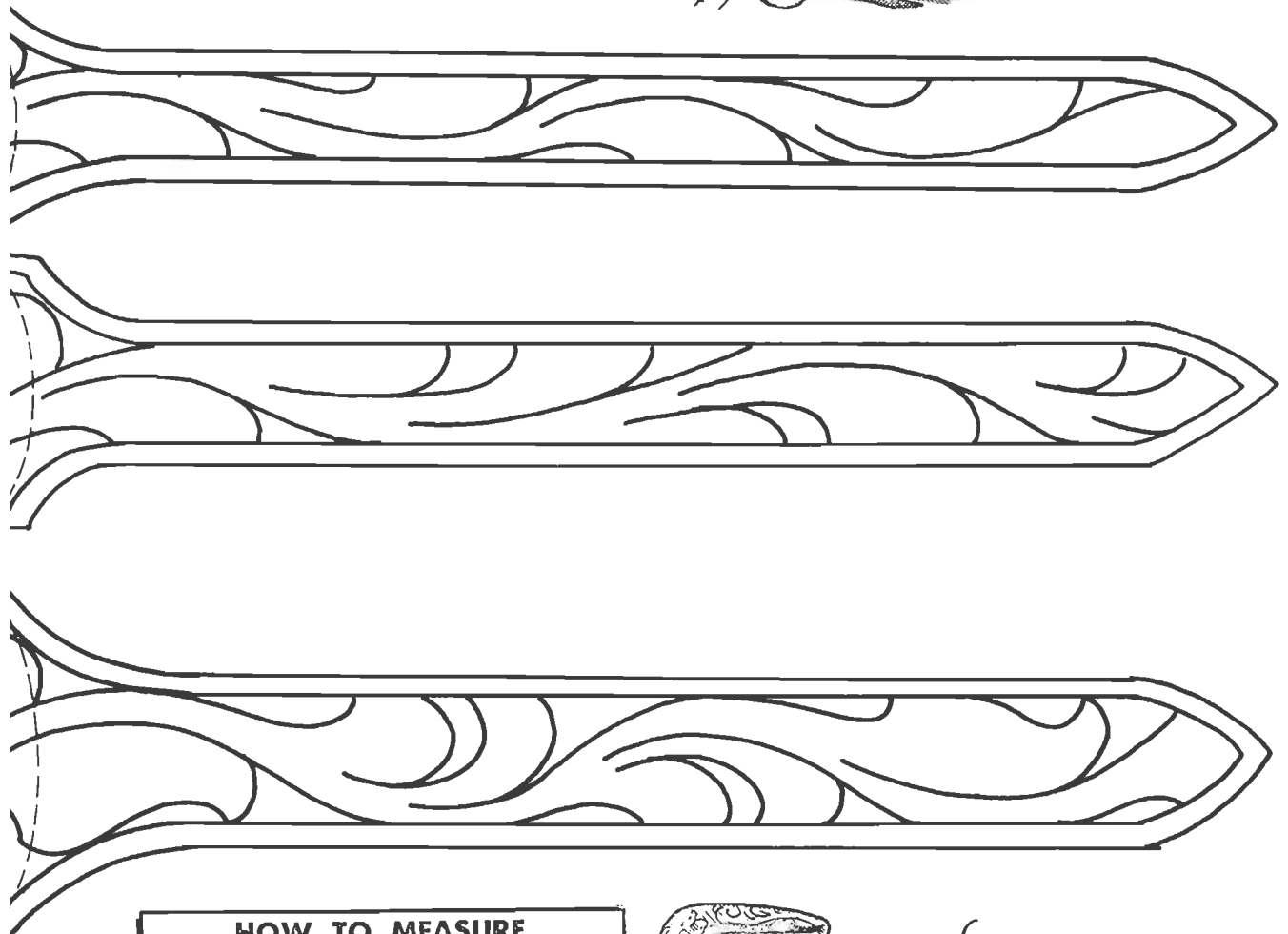
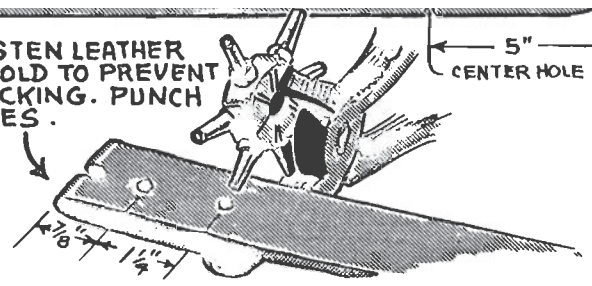

**HOW TO MEASURE
A BUCKLE**



BAR BUCKLE

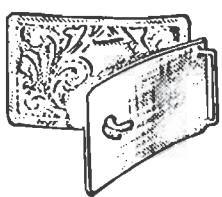

HOOK BUCKLE

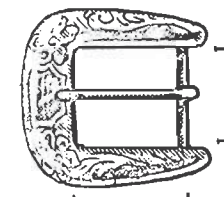

WIDTH

LENGTH

This distance deter-
mines width of belt
or tapered billet.

NOTE:

Most buckle widths are
made slightly oversize for
freedom of strap. Approxi-
mately 1/32".

This distance must be in-
cluded in the measure

E
al
y
o
e
k



© Copyright 2010 by Tandy Leather Factory
All Rights Reserved

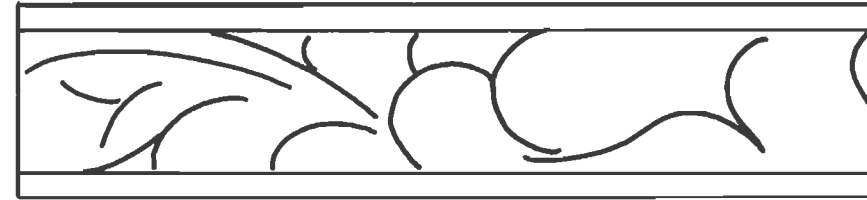
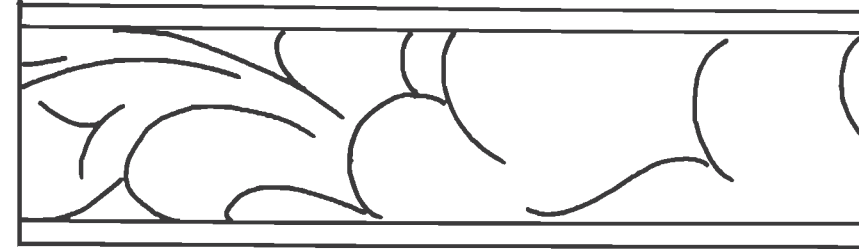
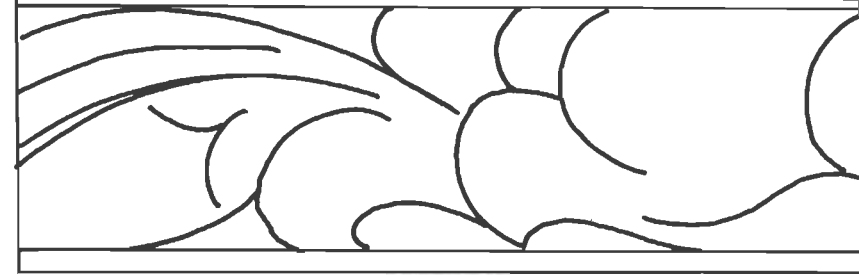

1¼-INCH LETTERS FOR 1½-INCH TROPHY BELTS

A B C D

P Q R S

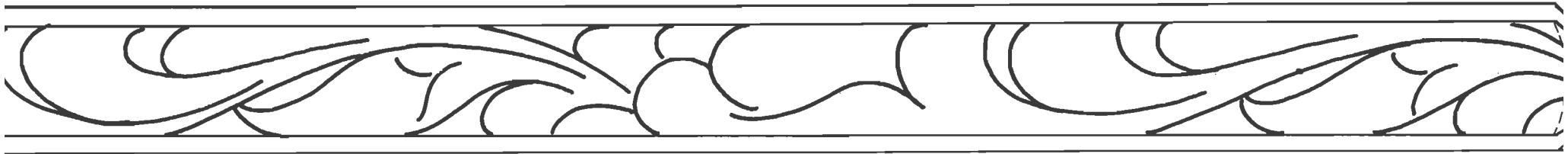
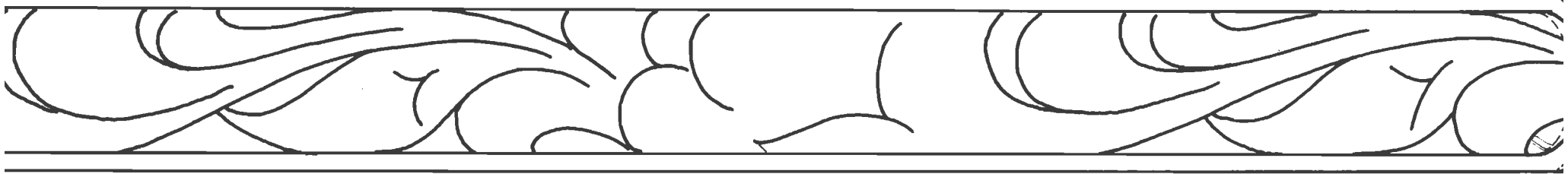

E F G H I J K

T U V W X Y

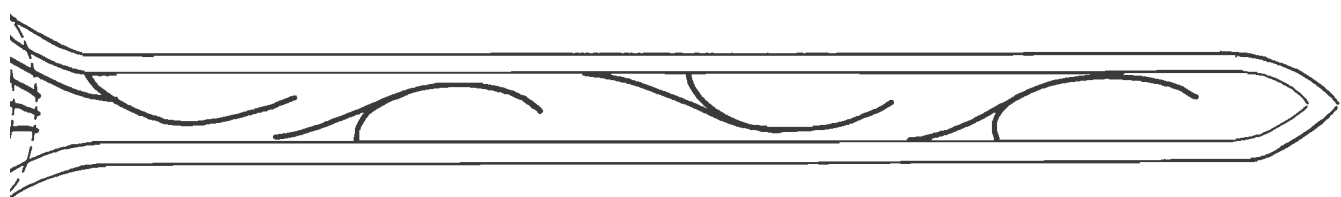
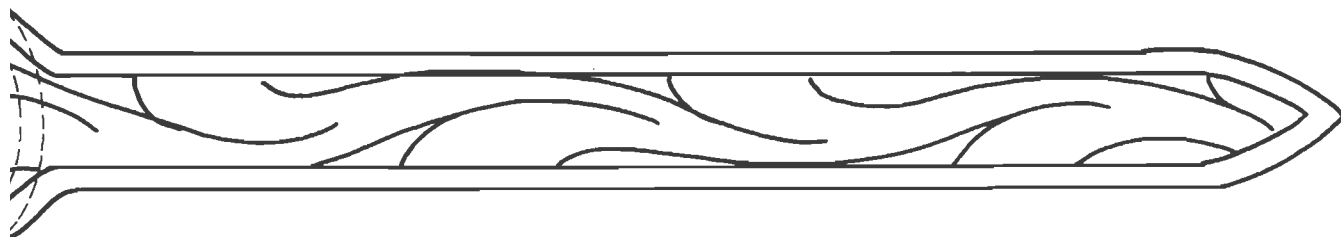
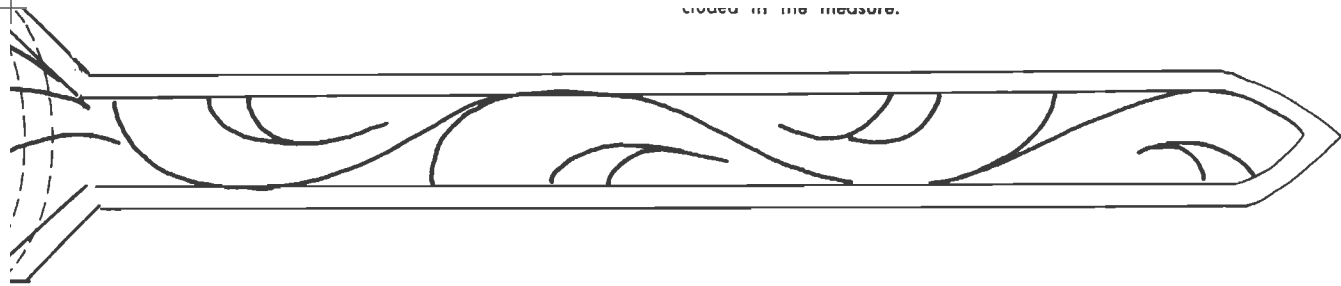

L M N O

Z

A B C D E F G H I

J K L M N O P Q R

S T U V W X Y Z

1-INCH LETTERS FOR 1¼-INCH BELTS

A B C D E F

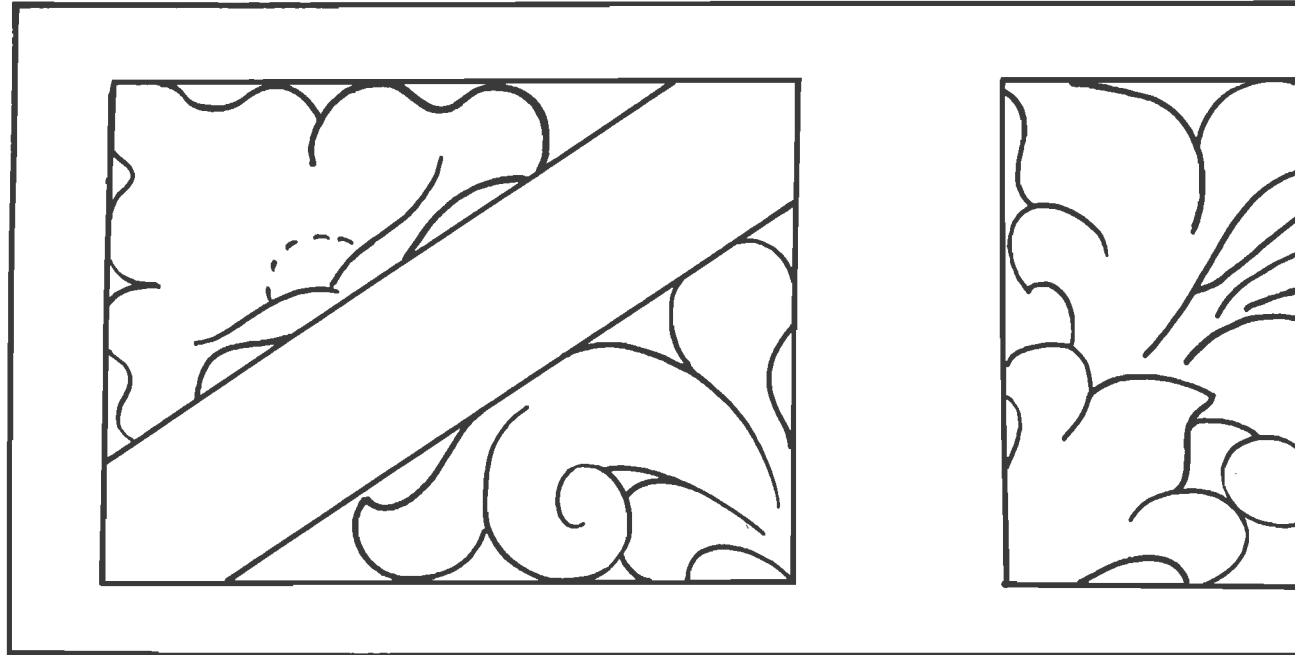

¾-INCH LETTERS FOR 1-INCH BELTS

A B C D E F G
H I J K L M N O P
Q R S T U V W X Y Z

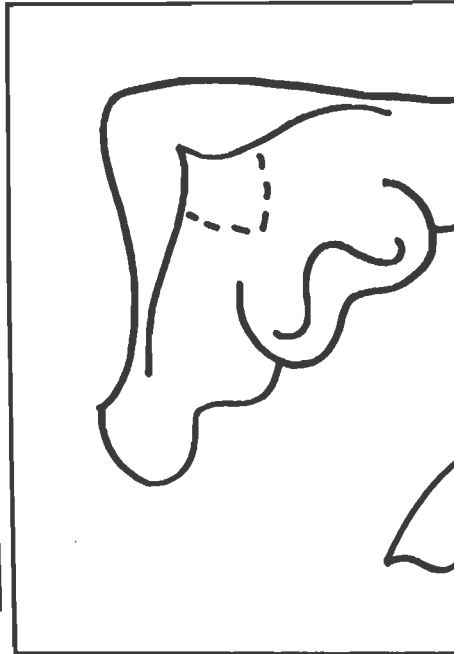
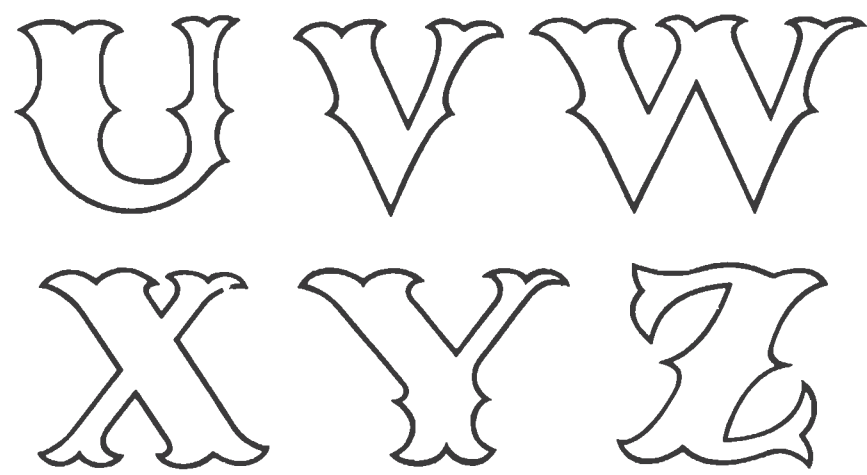
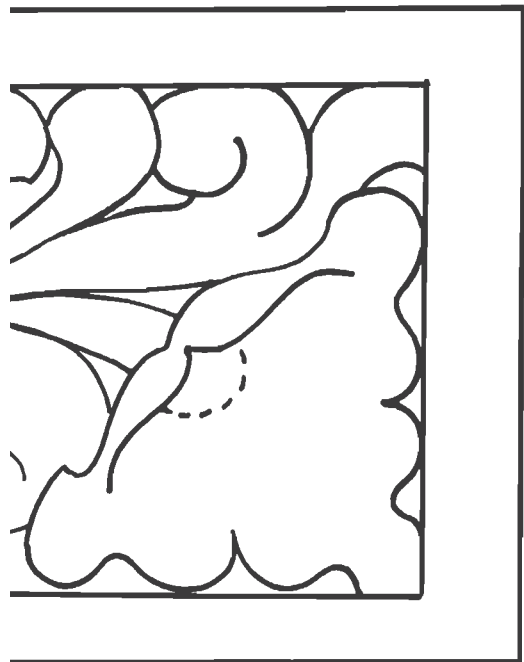
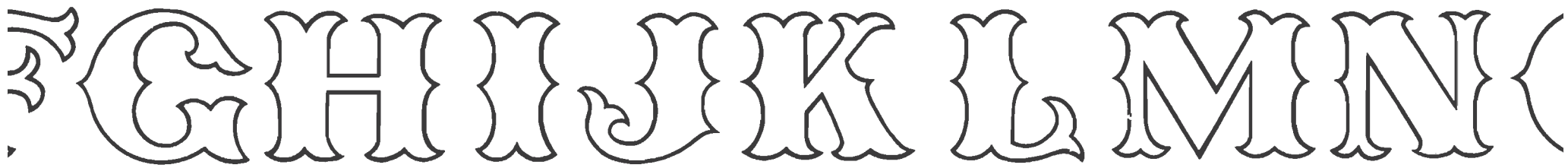

NEW "ALPHABET" CRAFTTOOLS

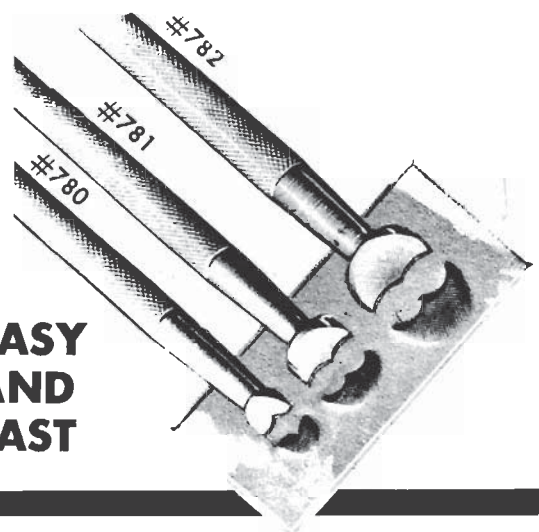

**EASY
AND
FAST**

**CARVE
LETTERS
WITHOUT A
SWIVEL
KNIFE**

NOW add name or initials to your leather quickly **WITHOUT TEDIOUS SWIVEL K**TING. Just trace, stamp with new alphabet c bevel. Easy and fast to add new value, bring from your leatherwork every piece with the Alphabet Crafttools. **S** Order the set of **THI** Start **NOW** to plan sonalized Christmas gifts or profit!



CRAFTAID 3207 New Letters especially design Crafttools.



HOW TO SET SNAPS

ASSEMBLING INSTRUCTI

1. See Tooling Instructions.

O P Q R S T



work easily,
NIFE CUT-
 crafttools and
 new profits
 , Personalize
 aid of New
AVE
REE TODAY!
 your per-
 projects for



alphabet of 2"
 ed for Alphabet

ONS FOR BILLFOLDS



S T U V W X

1/2-INCH LETTERS FOR BILLFOLDS, ETC.

A B C D E F G H I J
N O P Q R S T U V W

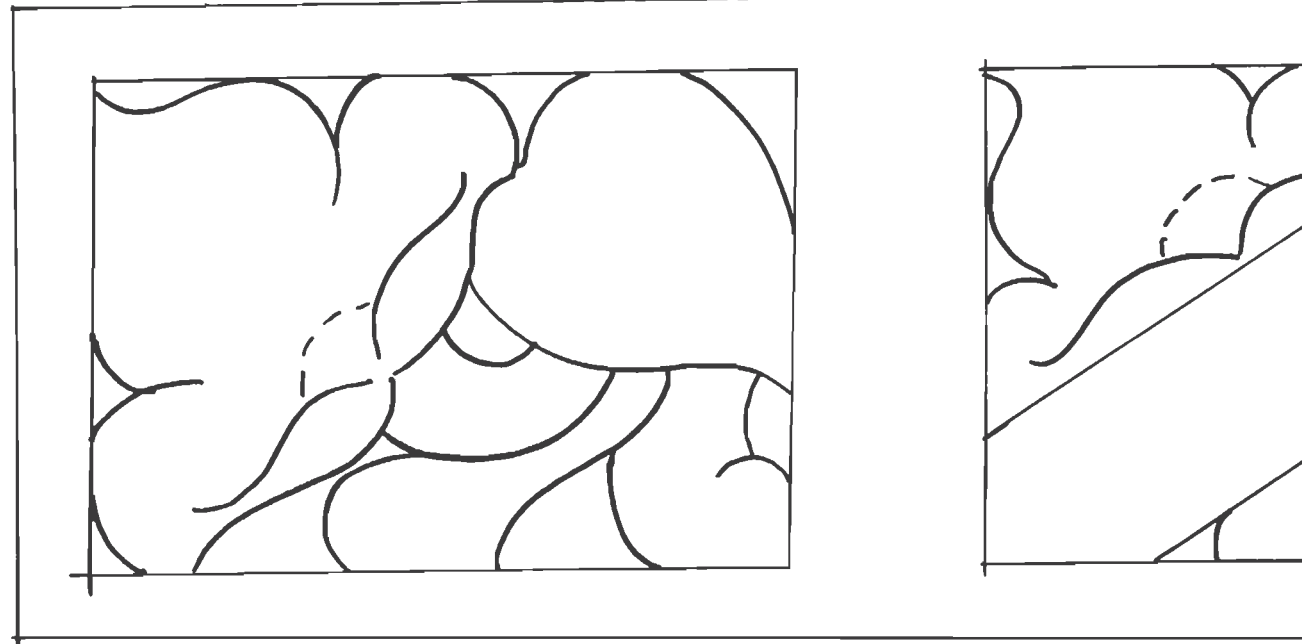

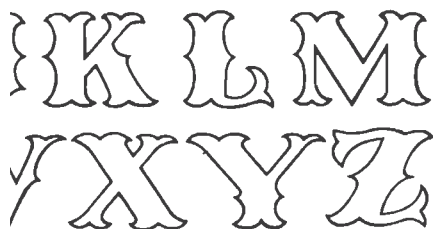

1. Check four parts of snap as shown below. The button and socket form one unit, stud and eyelet the other. Both Segma and Birdcage Snaps are set in the same manner.

2. Locate and punch a hole of the correct size for socket.

3. Place socket over correct anvil of the plate (see chart below). Push leather down over socket, grain side up. Then put button on the socket.

4. Place the large concave punch on top of button. Strike punch with mallet, thus setting the button and socket.

5. Locate and punch hole of correct size for eyelet.

6. Place eyelet over small anvil in the center of plate, then put leather over the eyelet and the stud over eyelet and leather. Check to see that it's not backwards.

BUTTON



SOCKET

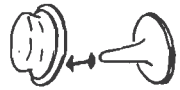

STUD



EYELET

7. Choose proper punch (see chart) over stud. Strike punch with mallet, thus setting stud and eyelet.

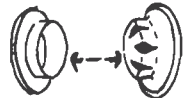

EYELET



STUD

BUTTON

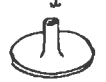

SOCKET

2. After you have tooled the billfold back and the parts together and let them set till the cement is

3. It is in billfolds that you can get the best selling or. Dye the billfold before you lace it. When using NEAT-LAC and dye on the same article

- A. When the background is to be dyed, you apply the
 - B. When other parts of leather are to be dyed you do
- Example. If you had a billfold and you wanted to you would
- 1st. Dye the flower yellow.
 - 2nd. Apply NEAT-LAC all over.
 - 3rd. Apply blue background dye.

4. In lacing all the parts together, be sure that the edge you go.

5. When you are finished lacing, and have glued the ends dampen the lacing, and then beat the lacing flat. appearance.

6. Put a card in the billfold with your name, address, and who gets the billfold to give the card to the first person

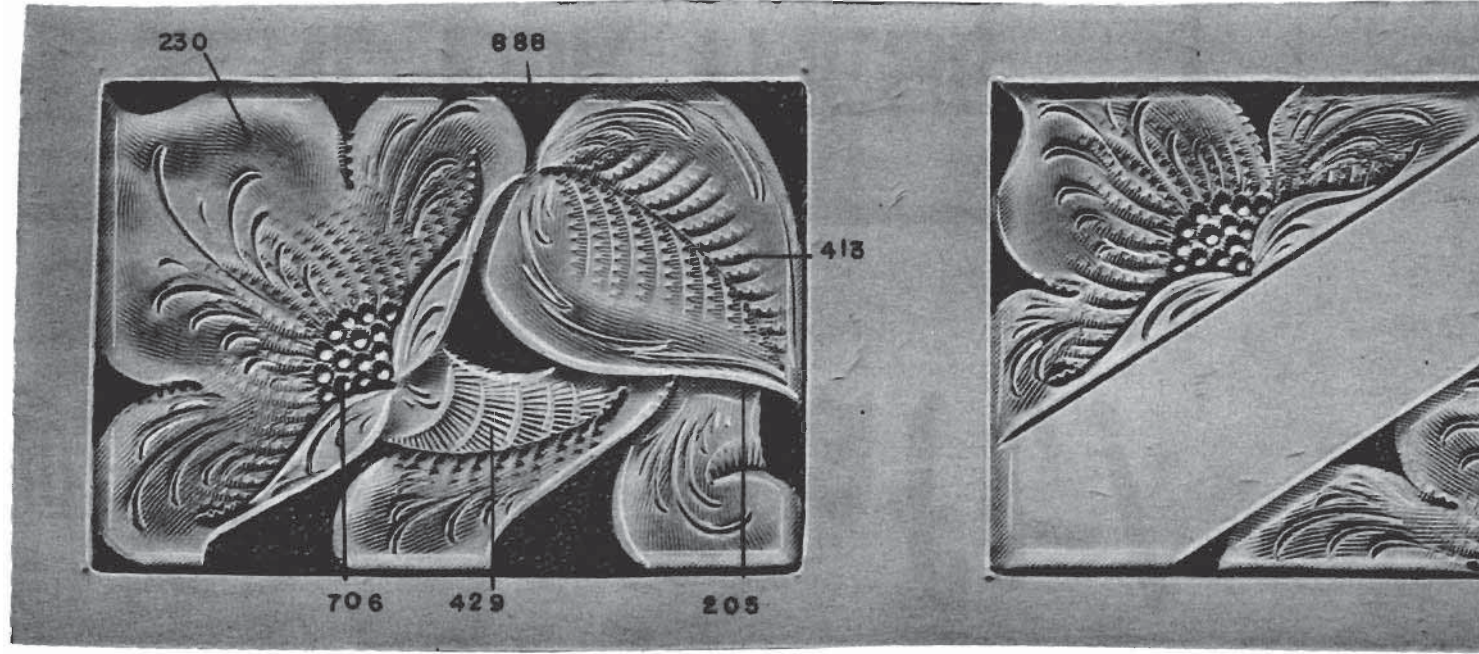
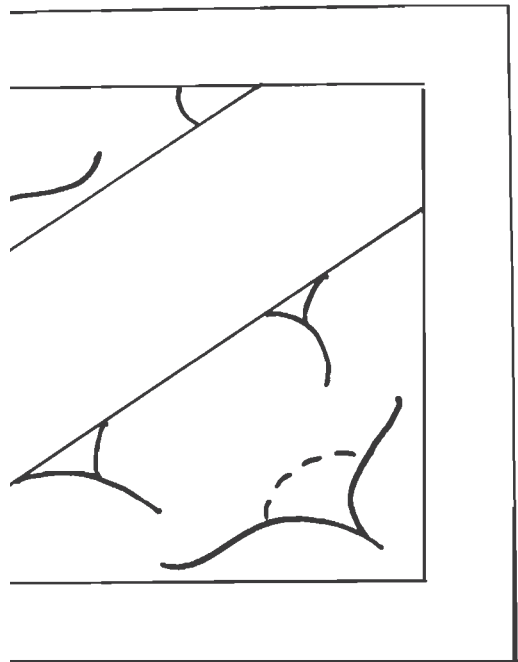

inside decorative corners, you should cement the well set.

power of leather dyes. Women use a lot of col-

here are the rules to remember:
he NEAT*LAC first and then dye the leather.
lye first and then NEAT*LAC.
dye the flower yellow and the background blue,

zes are even. Always tighten the lacing as

ids in and have trimmed the pieces, you should
This will give the lacing the correct finished

and telephone number on it. Ask the person
rson who mentions its beauty.



9/1/60

