

ARISTOCRAT HAT PATTERN



MATERIALS NEEDED:
 4-5 oz. Nature-Tand or Live Oak
 4 yds. 1/8" Indian Tan Lace
 Latigo Life-Eye Lacing Needle
 Punch Size 3
 Knife
 Craftsman Cement
 Omega Dye
 Omega Carnuba Cream or Finish Coat



©Copyright 2010 by Tandy Leather Factory
 All Rights Reserved

ASSEMBLY INSTRUCTIONS

Step 1: Use the cutting patterns to cut the leather parts and punch the lacing holes. Dye the leather parts. The lace may also be dyed if desired.

Use this chart to determine your hat size:

SIZE	HEAD MEASUREMENT
Small	21" to 22"
Medium	22 1/4" to 23"
Large	23 1/4" to 24"

Upon completion of your hat, if it is slightly small, use water to moisten the inside area of the hat, and push it down over your head in place. Wear it until it dries, and it will adjust to your size.

Step 2: Beginning with the second hole, lace the ends of the Crown Panel together with three feet of lace following the Cross Stitch Lacing Instructions. Do not lace through the bottom holes.

Step 3: Lace the Top to the top side of the Crown Panel with four feet of lace following the Running Stitch Lacing Instructions. Align the notch in the Top with the seam of the Crown Panel. Lightly dampening and forming the edges of the parts with water will make assembly easier.

Step 4: Cement the two Brim parts together with Craftsman Cement, flesh side to flesh side, with the lacing holes aligned. Leave 1/2" not cemented on the inside edge.

Step 5: Insert the bottom side of the Crown Panel between the two inside edges of the Brim that were not cemented together. Align the notch in the Brim with the seam where the Crown Panel is joined together. With the lacing holes aligned, lace the parts together with four feet of lace with a Running Stitch. Lightly dampening and forming the edges of the parts with water will make assembly easier.

Step 6: Lightly dampen with water the Brim area to be formed, and shape it as desired. As the Brim dries it will retain the shape formed. Apply a leather finish such as Omega Carnuba Cream or Finish Coat to the leather.

RUNNING STITCH INSTRUCTIONS

Step 1: Insert one end of the 1/8" Indian Tan Lace in the Latigo Life-Eye Lacing Needle.

Step 2: Begin lacing in between the two leathers, leaving a very short end.

Step 3: Lace the parts together with a Running Stitch as shown. Lace to the last hole.

Step 4: Pull the lace out between the two leathers and cut off the excess lace. Cement the ends in place between the leathers with Craftsman Cement.

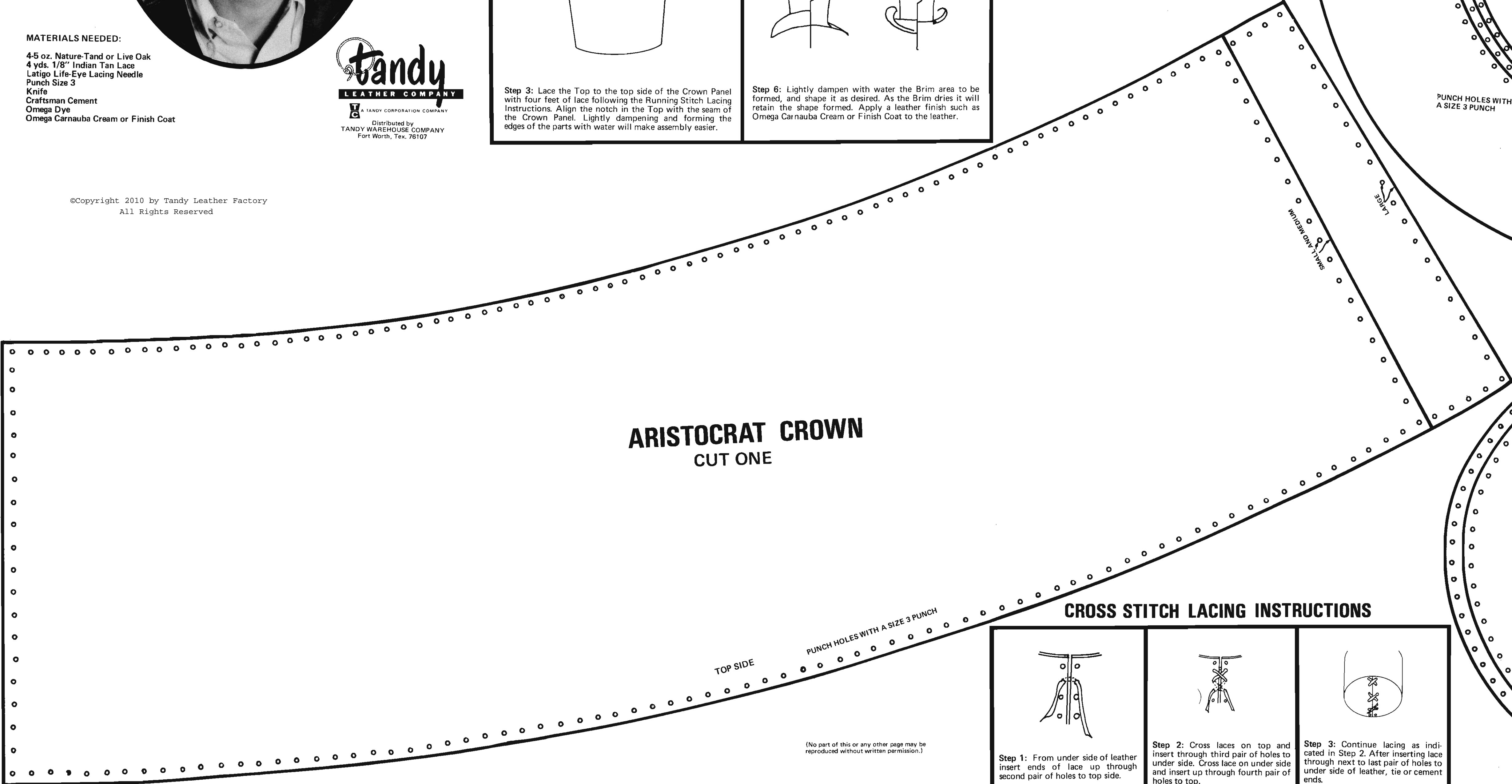
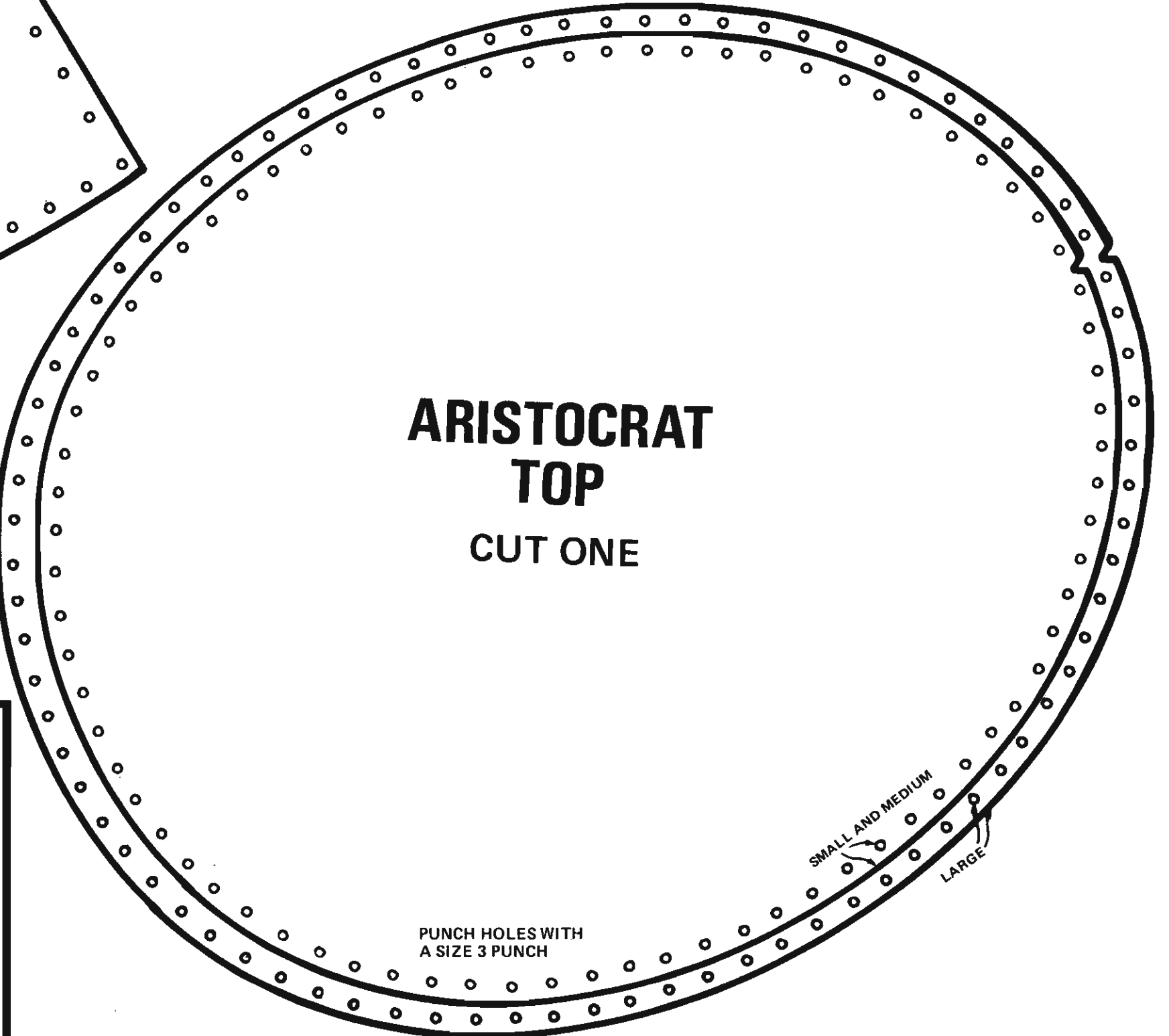
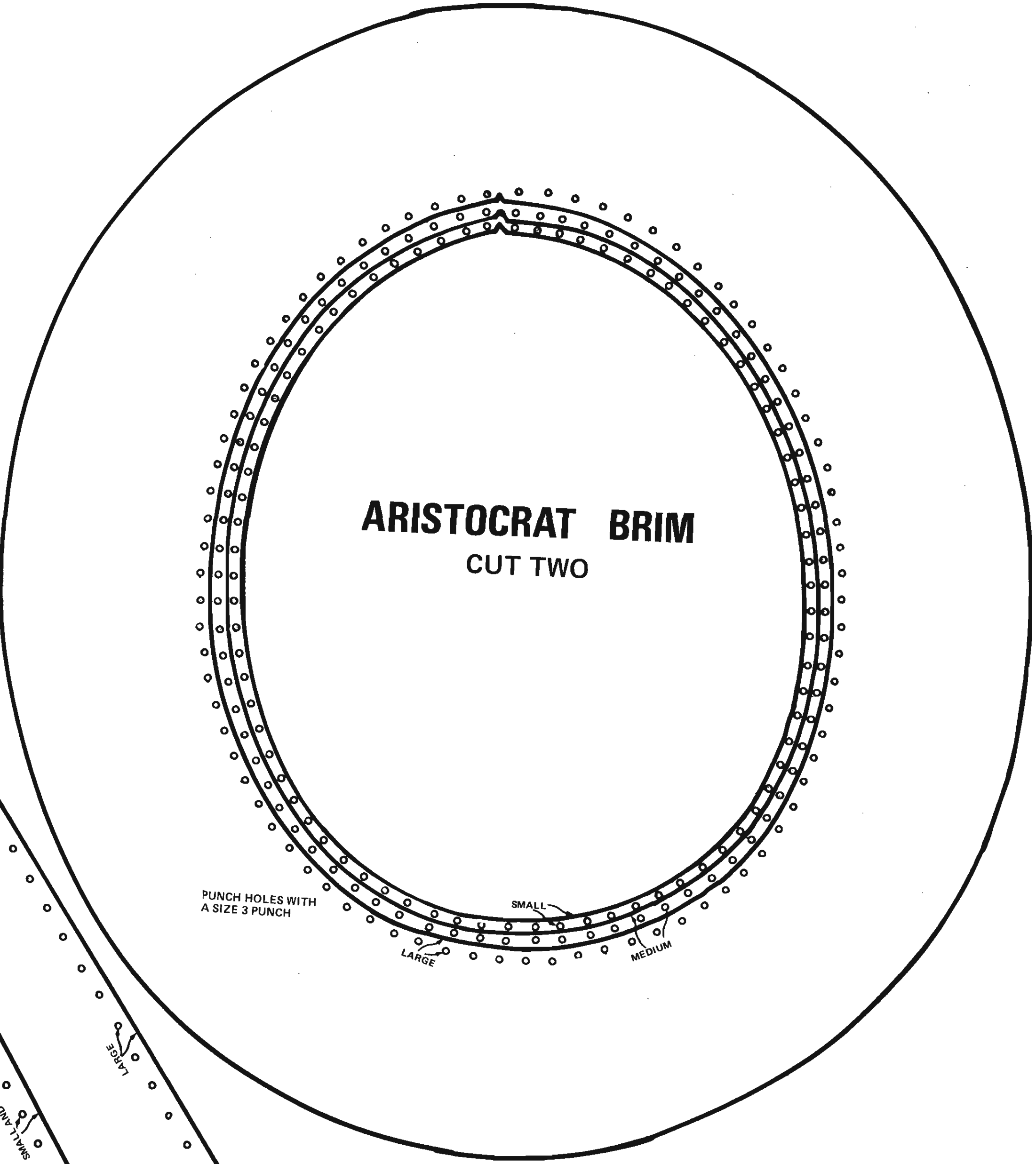

CROSS STITCH LACING INSTRUCTIONS

Step 1: From under side of leather insert ends of lace up through second pair of holes to top side.

Step 2: Cross laces on top and insert through third pair of holes to under side. Cross lace on under side and insert up through fourth pair of holes to top.

Step 3: Continue lacing as indicated in Step 2. After inserting lace through next to last pair of holes to under side of leather, tie or cement ends.

(No part of this or any other page may be reproduced without written permission.)

©Copyright 2010 by Tandy Leather Factory
All Rights Reserved

ARISTOC HAT PAT

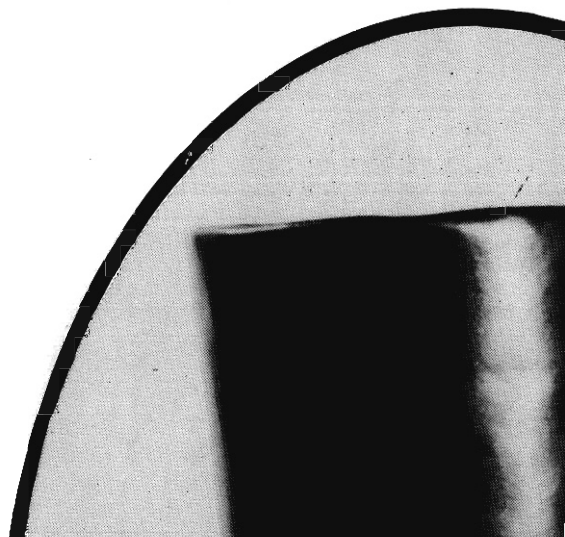

BOCRAT WATERN

ASSEMBLY IN

Step 1: Use the cutting patterns to cut the leather parts and punch the lacing holes. Dye the leather parts. The lace may also be dyed if desired.

Use this chart to determine your hat size:

SIZE	HEAD MEASUREMENT
Small	21" to 22"
Medium	22 1/4" to 23"
Large	23 1/4" to 24"

Upon completion of your hat, if it is slightly small, use water to moisten the inside area of the hat, and push it down over your head in place. Wear it until it dries, and it will adjust to your size.

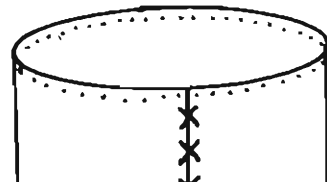

INSTRUCTIONS

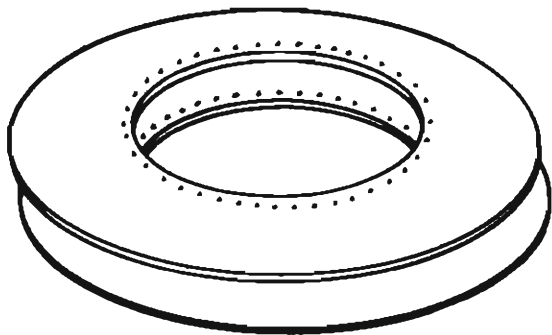

Step 4: Cement the two Brim parts together with Craftsman Cement, flesh side to flesh side, with the lacing holes aligned. Leave 1/2" not cemented on the inside edge.

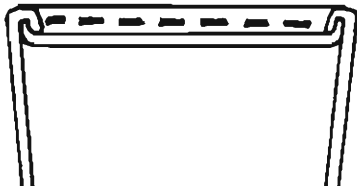

RUNNING STITCH INSTR



Step 1: Insert one end of the 1/8" Indian Life-Eye Lacing Needle.



Step 2: Begin lacing in between the two leaf end.



INSTRUCTIONS



Tan Lace in the Latigo



ers, leaving a very short

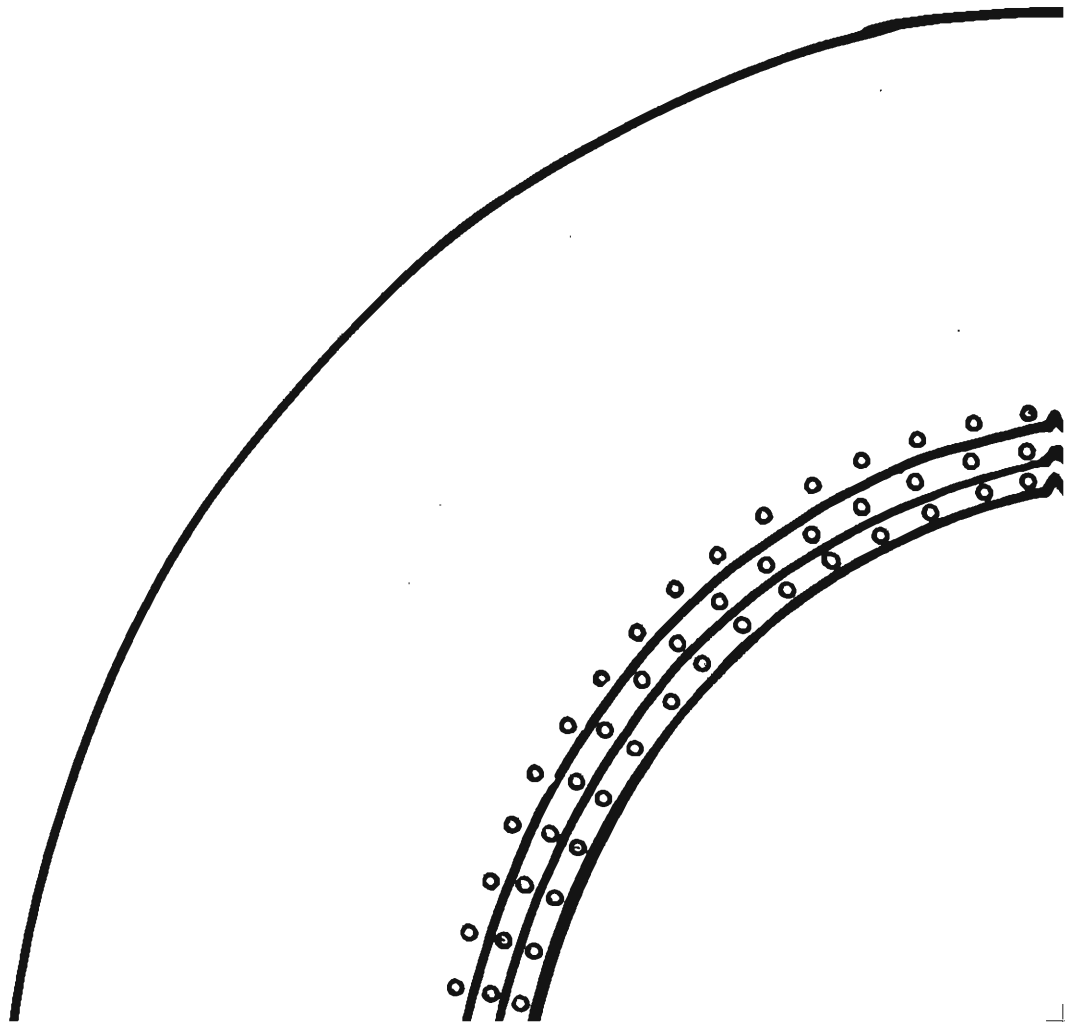

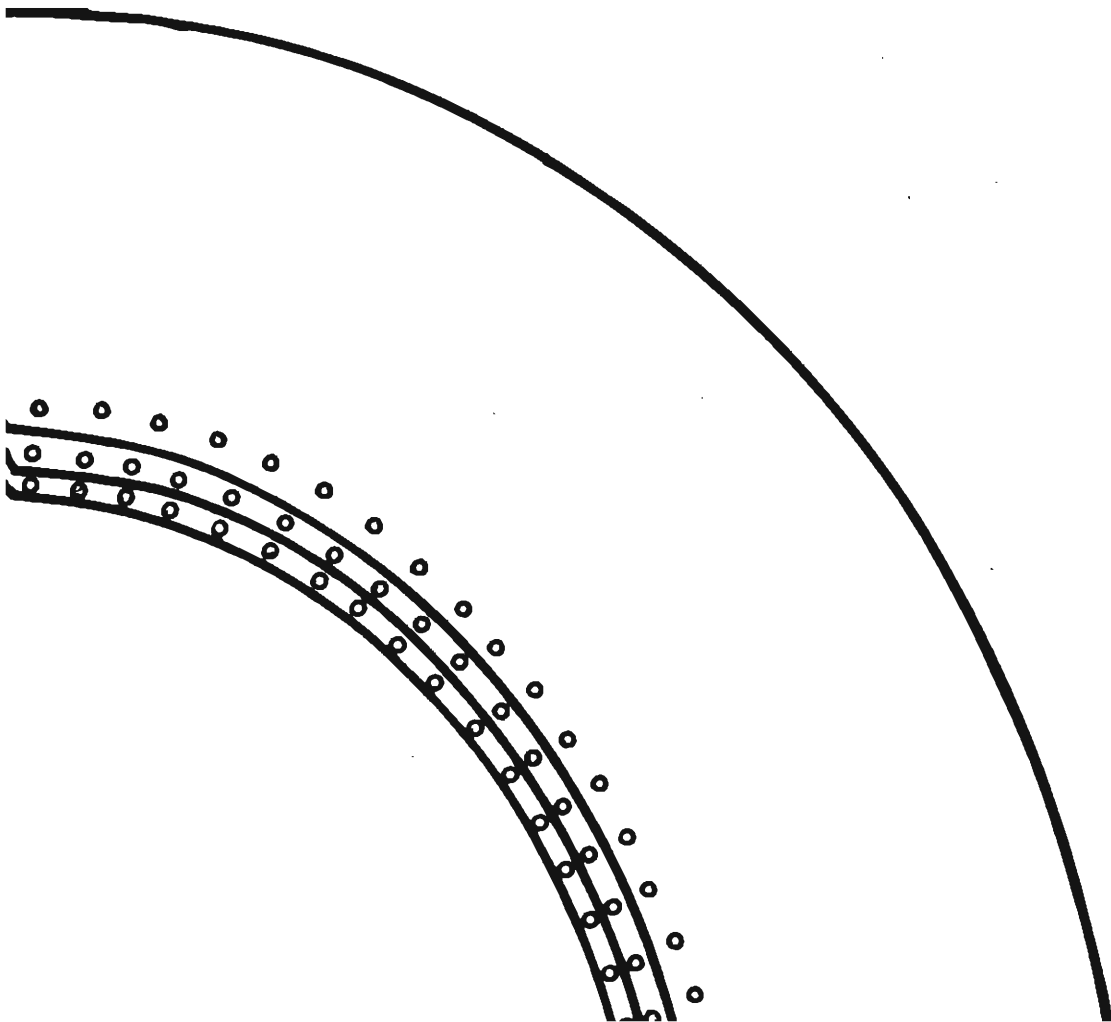

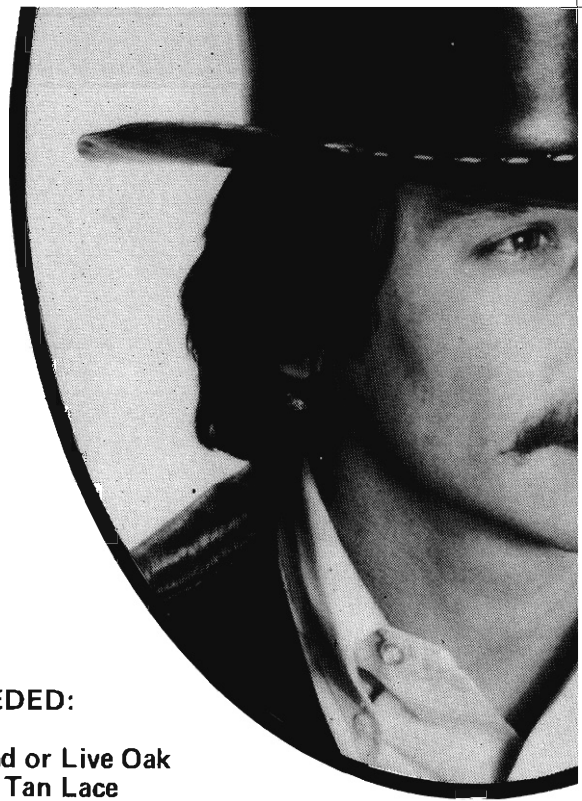

MATERIALS NEEDED:

- 4-5 oz. Nature-Tand or Live Oak**
- 4 yds. 1/8" Indian Tan Lace**
- Latigo Life-Eye Lacing Needle**
- Punch Size 3**
- Knife**
- Craftsman Cement**
- Omega Dye**
- Omega Carnauba Cream or Finish Coat**

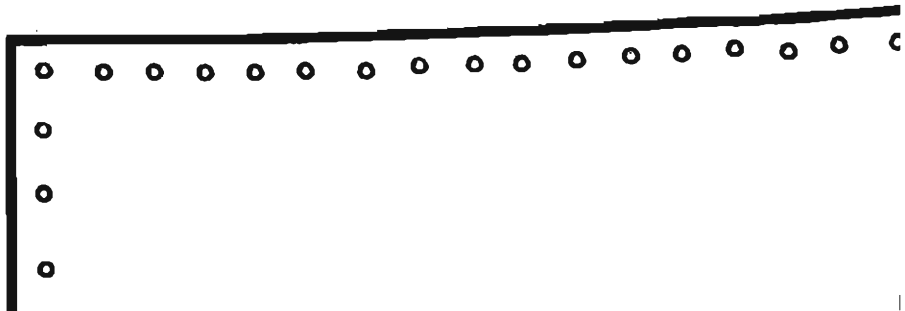



tandy
LEATHER COMPANY

T C A TANDY CORPORATION COMPANY

Distributed by
TANDY WAREHOUSE COMPANY
Fort Worth, Tex. 76107

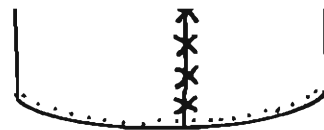

Step 2: Beginning with the second hole, lace the ends of the Crown Panel together with three feet of lace following the Cross Stitch Lacing Instructions. Do not lace through the bottom holes.

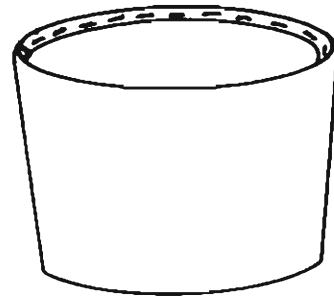

Step 3: Lace the Top to the top side of the Crown Panel with four feet of lace following the Running Stitch Lacing Instructions. Align the notch in the Top with the seam of the Crown Panel. Lightly dampening and forming the edges of the parts with water will make assembly easier.

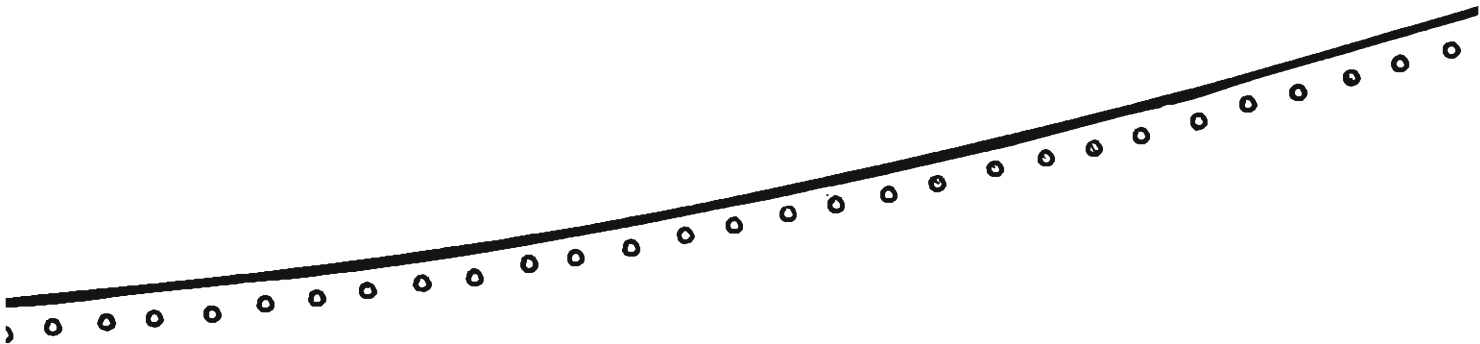



Step 5: Insert the bottom side of the Crown Panel between the two inside edges of the Brim that were not cemented together. Align the notch in the Brim with the seam where the Crown Panel is joined together. With the lacing holes aligned, lace the parts together with four feet of lace with a Running Stitch. Lightly dampening and forming the edges of the parts with water will make assembly easier.

Step 3: Lace the parts together with a Running Stitch to the last hole.



Step 4: Pull the lace out between the two excess lace. Cement the ends in place between Craftsman Cement.

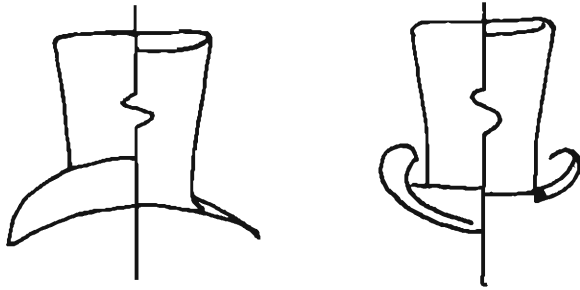

Step 6: Lightly dampen with water the Brim area to be formed, and shape it as desired. As the Brim dries it will retain the shape formed. Apply a leather finish such as Omega Carnauba Cream or Finish Coat to the leather.

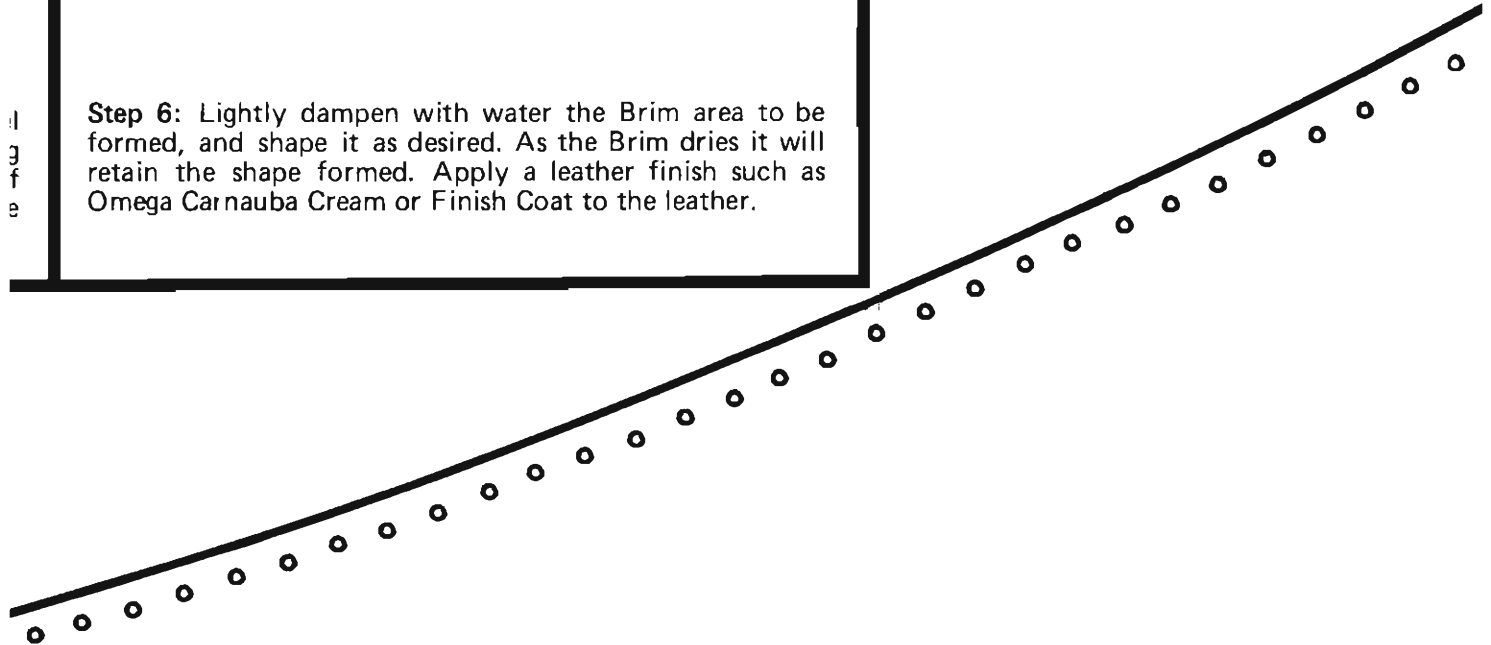

ARISTOC CU

ng Stitch as shown. Lace

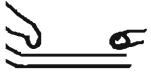

leathers and cut off the
ween the leathers with

PUNCH HOLES WITH
A SIZE 3 PUNCH

LARGE

LARGE

SMALL AND MEDIUM

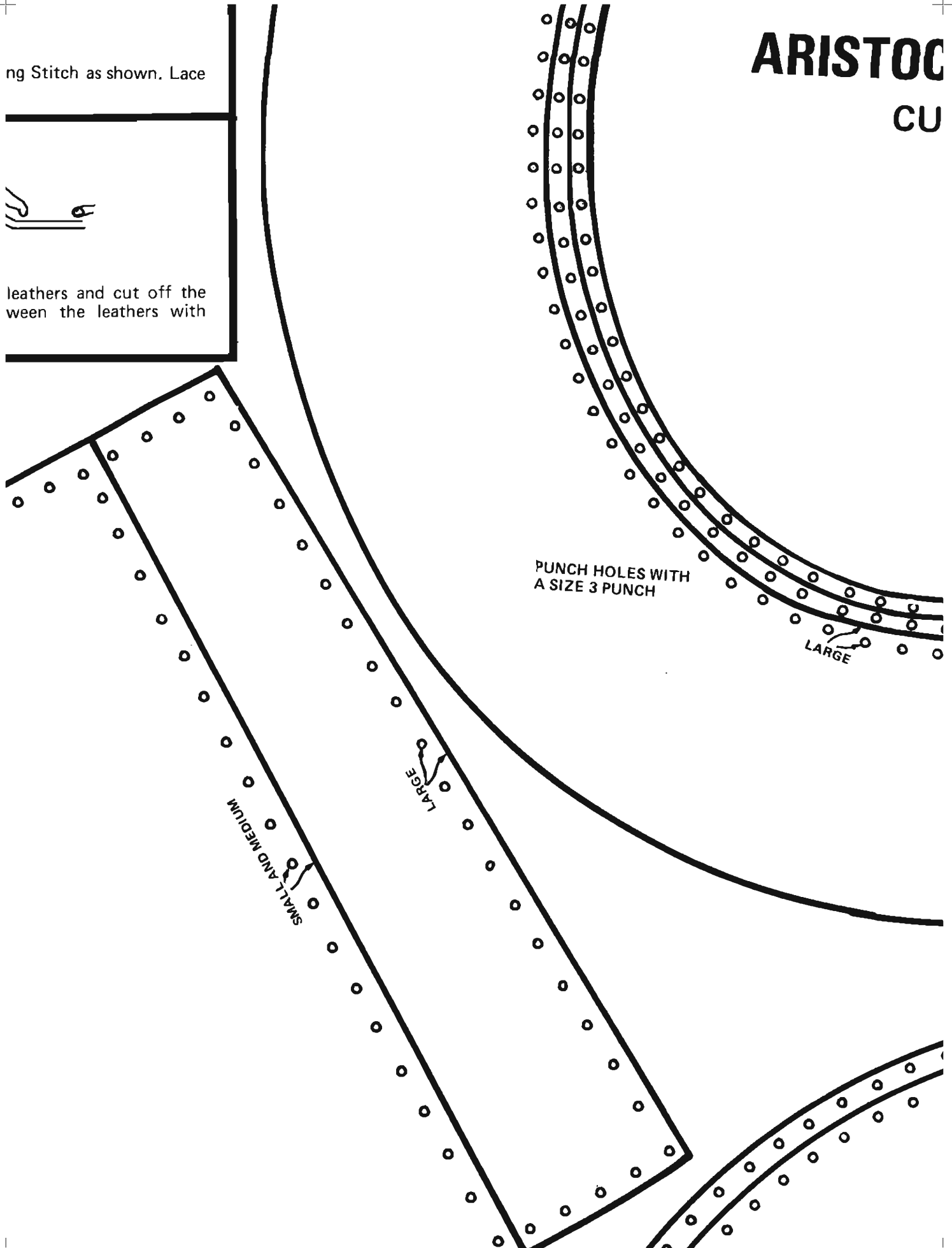

CRAT BRIM

T TWO

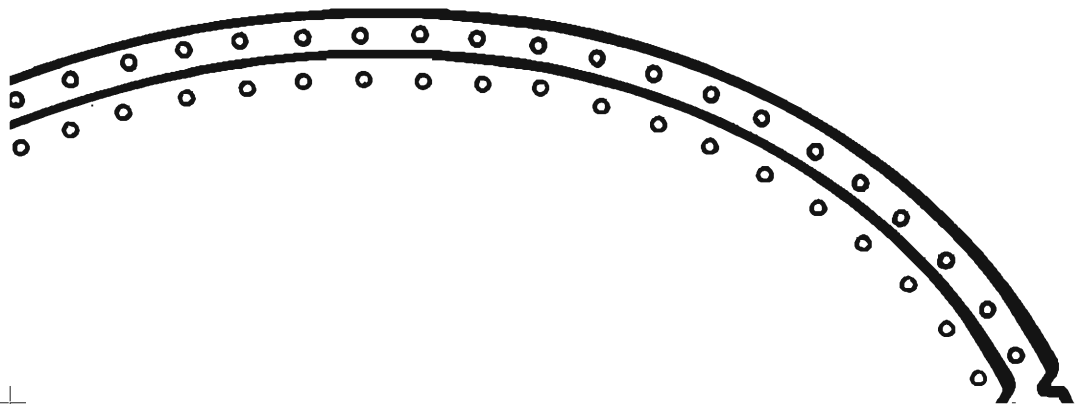
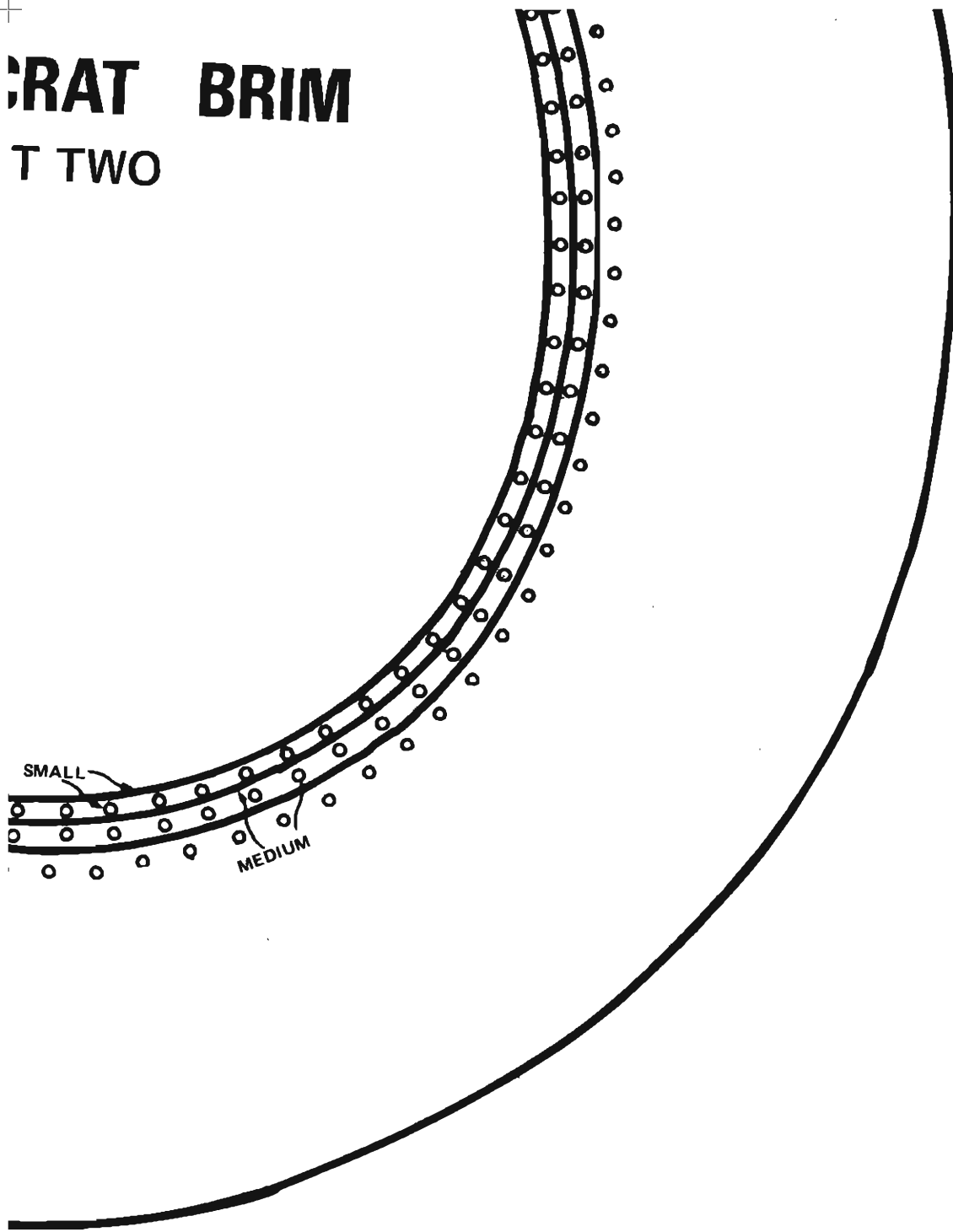

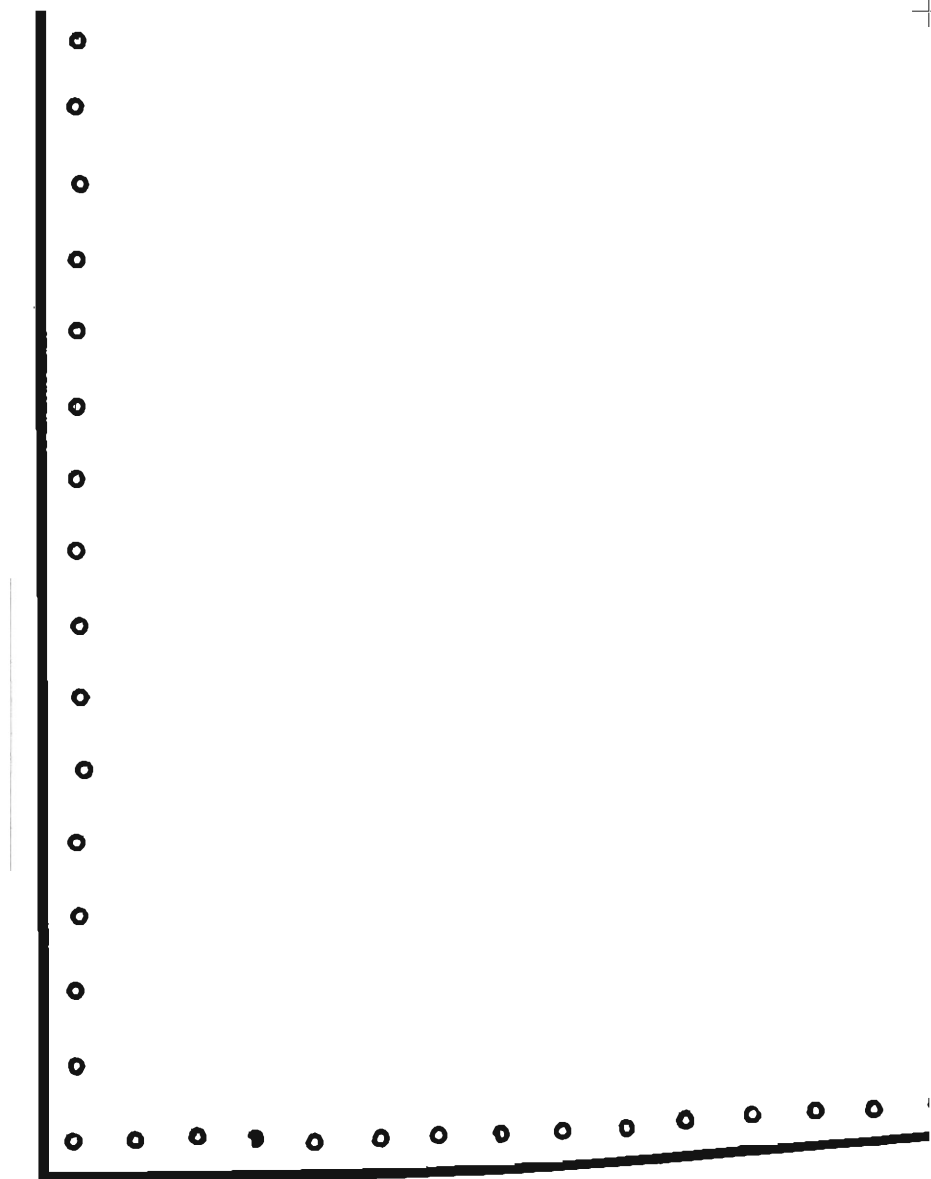

ARISTOCI CUT

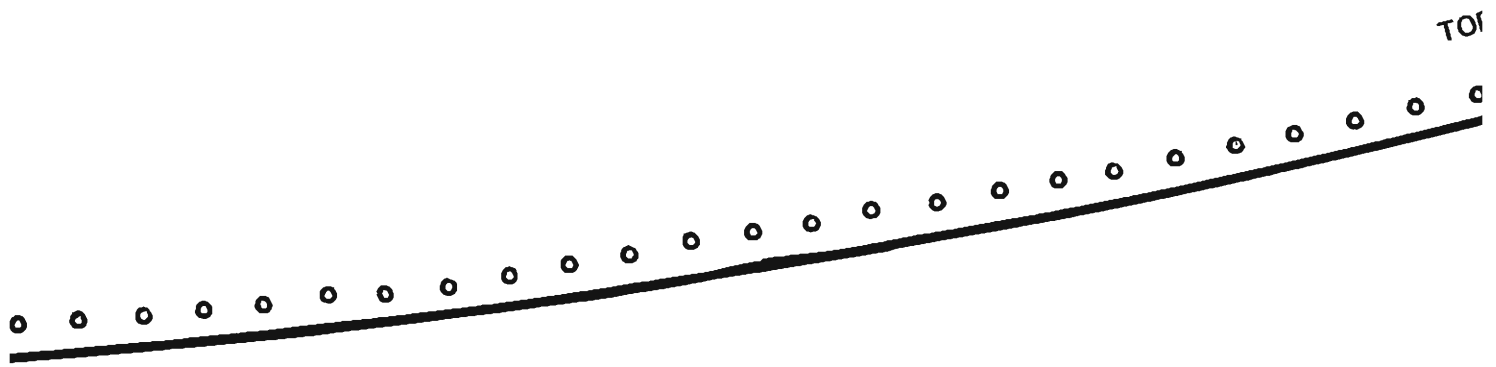

RAI CROWN

ONE

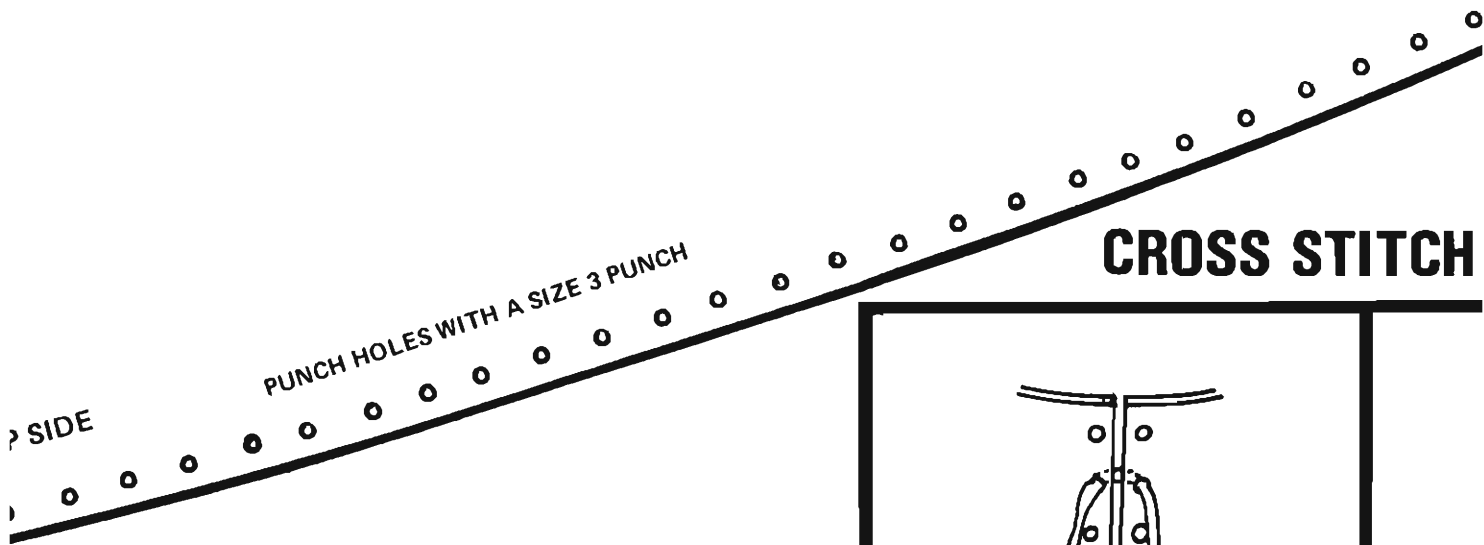

CROSS STITCH

(No part of this or any other page may be reproduced without written permission.)

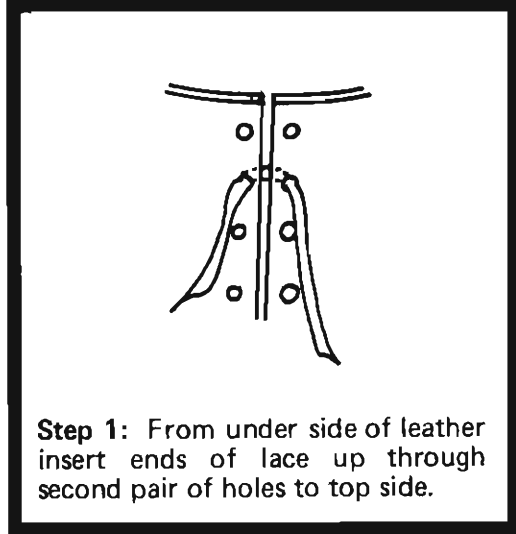

Step 1: From under side of leather insert ends of lace up through second pair of holes to top side.

Step 2
insert the lace through the first pair of holes to the under side and insert through the second pair of holes to the top side.

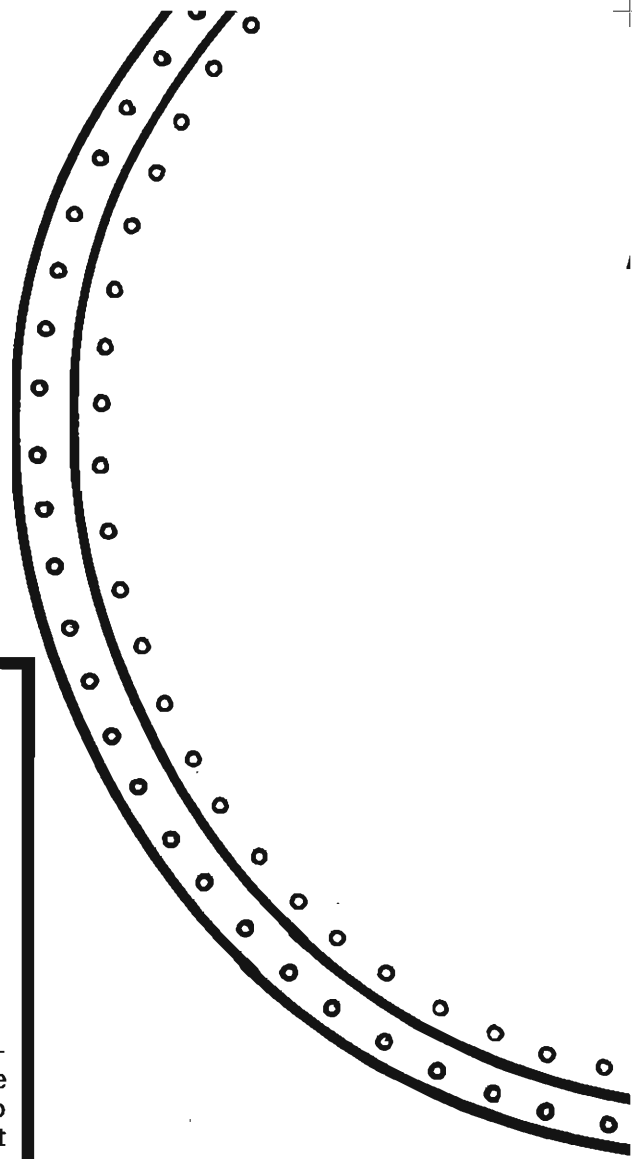
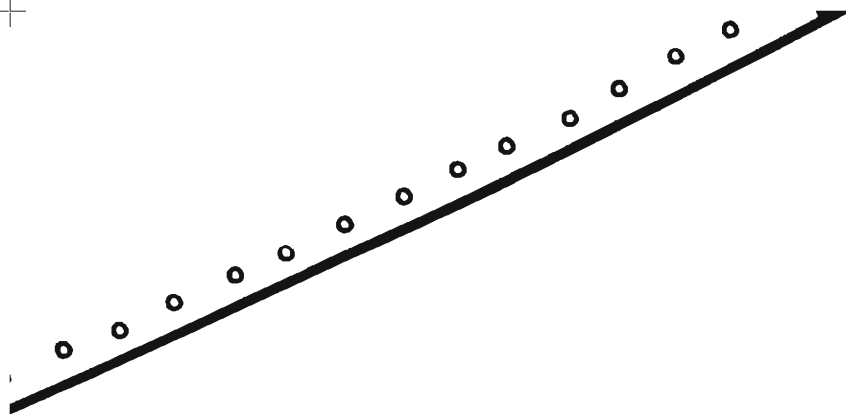

LACING INSTRUCTIONS

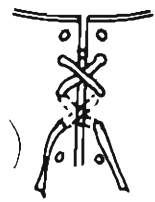

: Cross laces on top and through third pair of holes to side. Cross lace on under side part up through fourth pair of holes to top.

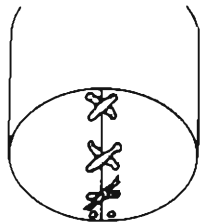

Step 3: Continue lacing as indicated in Step 2. After inserting lace through next to last pair of holes to under side of leather, tie or cement ends.

ARISTOCRAT TOP

CUT ONE

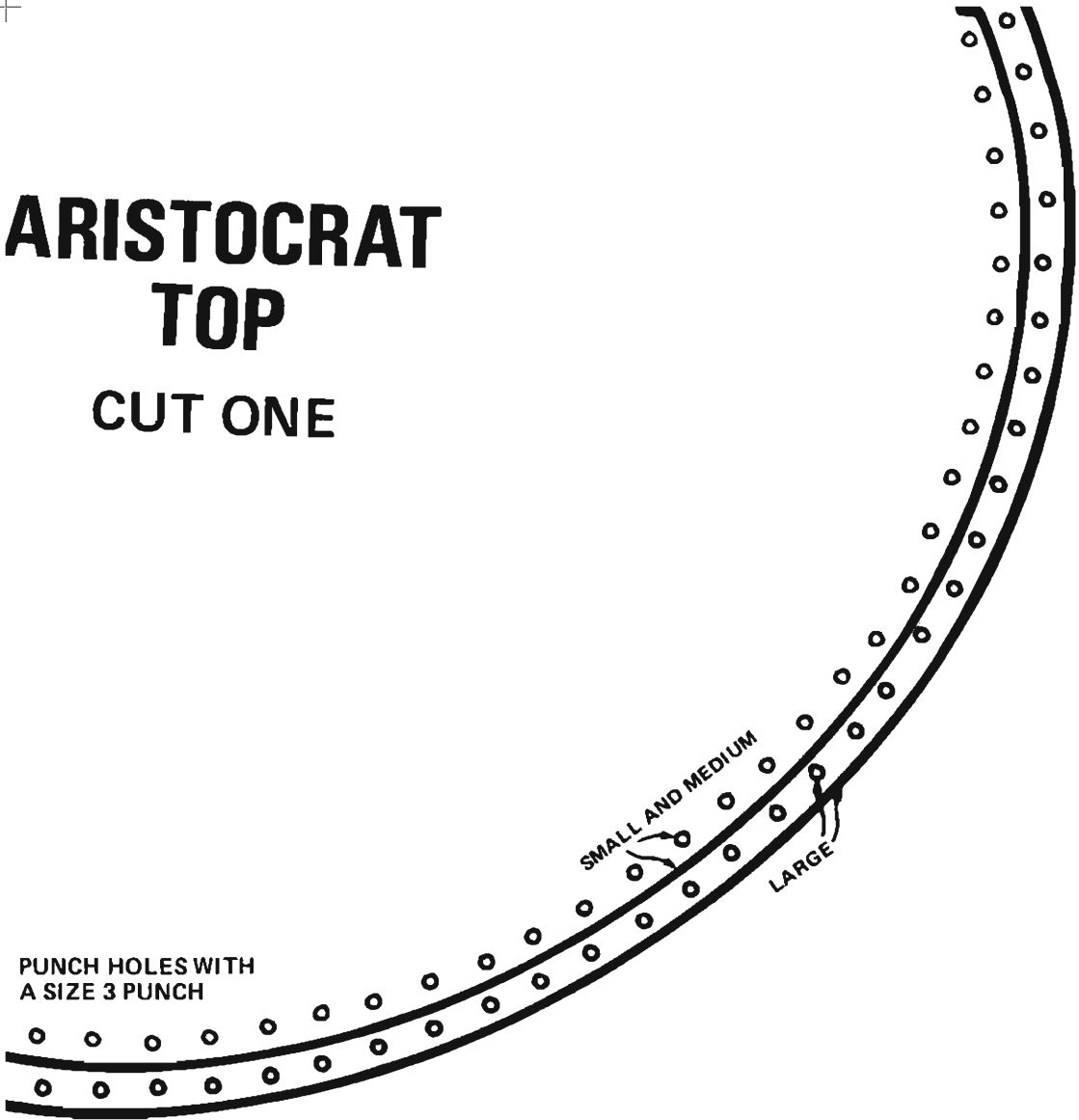

PUNCH HOLES WITH
A SIZE 3 PUNCH

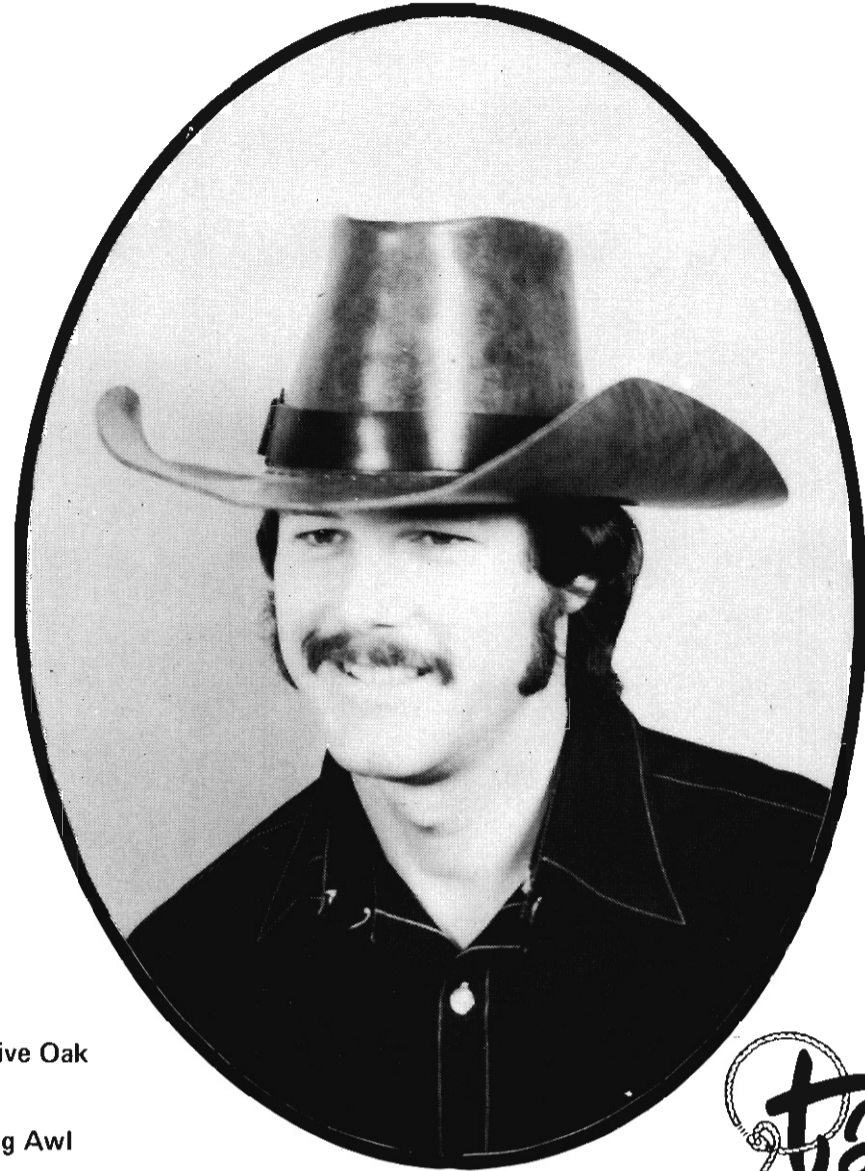

HOMBRE HAT PATTERN



Materials Needed:
 4-5 oz. Nature-Tand or Live Oak
 10 feet Waxed Thread
 Harness Needle Size 000
 Punch Size 00 or Stitching Awl
 Knife
 Buckle 1"
 Craftsman Cement
 Omega Dye
 Omega Carnauba Cream or Finish Coat

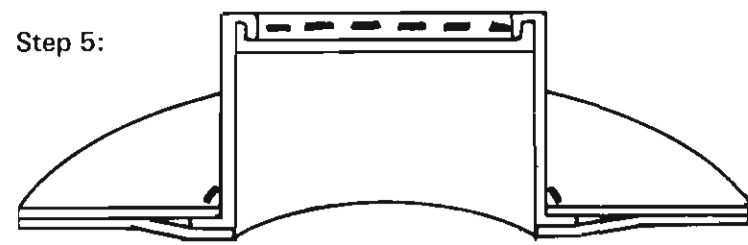
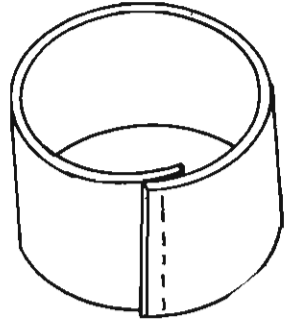
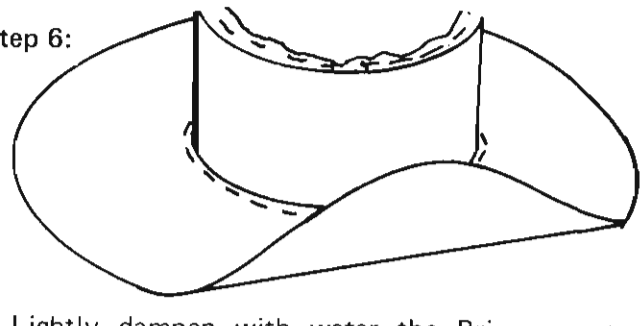
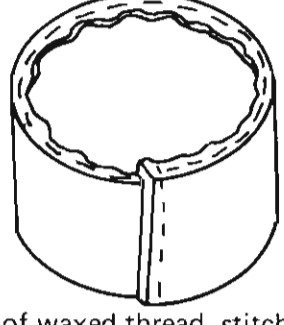
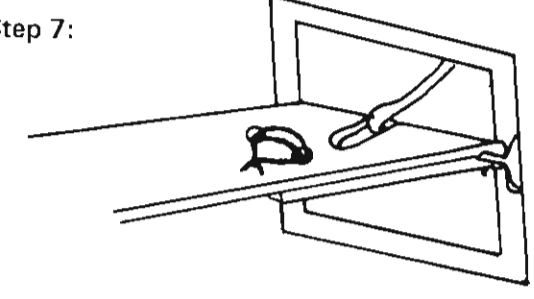

ASSEMBLY INSTRUCTIONS

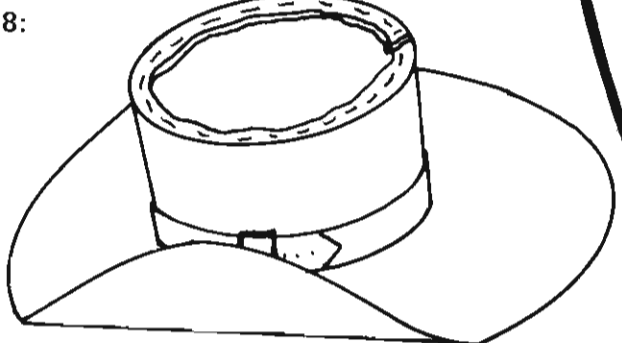
<p>Step 1: Use the cutting patterns to cut the leather parts and punch the stitch holes. Dye the leather parts. Use this chart to determine your hat size:</p> <table border="1" style="width: 100%;"> <thead> <tr> <th>SIZE</th> <th>HEAD MEASUREMENT</th> </tr> </thead> <tbody> <tr> <td>Small</td> <td>21" to 22"</td> </tr> <tr> <td>Medium</td> <td>22 1/4" to 23"</td> </tr> <tr> <td>Large</td> <td>23 1/4" to 24"</td> </tr> </tbody> </table> <p>Upon completion of your hat, if it is slightly small, use water to moisten the inside area of the hat, and push it down over your head in place. Wear it until it dries, and it will adjust to your size.</p>	SIZE	HEAD MEASUREMENT	Small	21" to 22"	Medium	22 1/4" to 23"	Large	23 1/4" to 24"	<p>Step 5:</p>  <p>Insert the bottom side of the Crown Panel between the two inside edges of the Brim that were not cemented together. Align the notch in the Brim with the row of stitching in the Crown Panel. Using four feet of waxed thread, stitch the parts together. Lightly dampening and forming the edges of the parts with water will make assembly easier.</p>
SIZE	HEAD MEASUREMENT								
Small	21" to 22"								
Medium	22 1/4" to 23"								
Large	23 1/4" to 24"								
<p>Step 2:</p>  <p>Using one foot of waxed thread, overlap the ends of the Crown Panel, align the holes and stitch along the holes following the Stitching Instructions.</p>	<p>Step 6:</p>  <p>Lightly dampen with water the Brim area to be formed, then shape as desired. As the Brim dries it will retain the shape formed. Apply a leather finish such as Omega Carnauba Cream or Finish Coat to the leather.</p>								
<p>Step 3:</p>  <p>Using four feet of waxed thread, stitch the Top to the top side of the Crown Panel. Align the notch in the Top with the row of stitching in the Crown Panel. Lightly dampening and forming the edges of the parts with water will make assembly easier.</p>	<p>Step 7:</p>  <p>Attach the buckle to the Hat Band with waxed thread.</p>								
<p>Step 4:</p>  <p>Cement the two Brim parts together with Craftsman Cement, flesh side to flesh side, with the stitching holes aligned. Leave 1/2" not cemented on the inside edge.</p>	<p>Step 8:</p>  <p>Buckle the Hat Band in place. If needed, the Hat Band can be cemented to the crown to hold it in place.</p>								

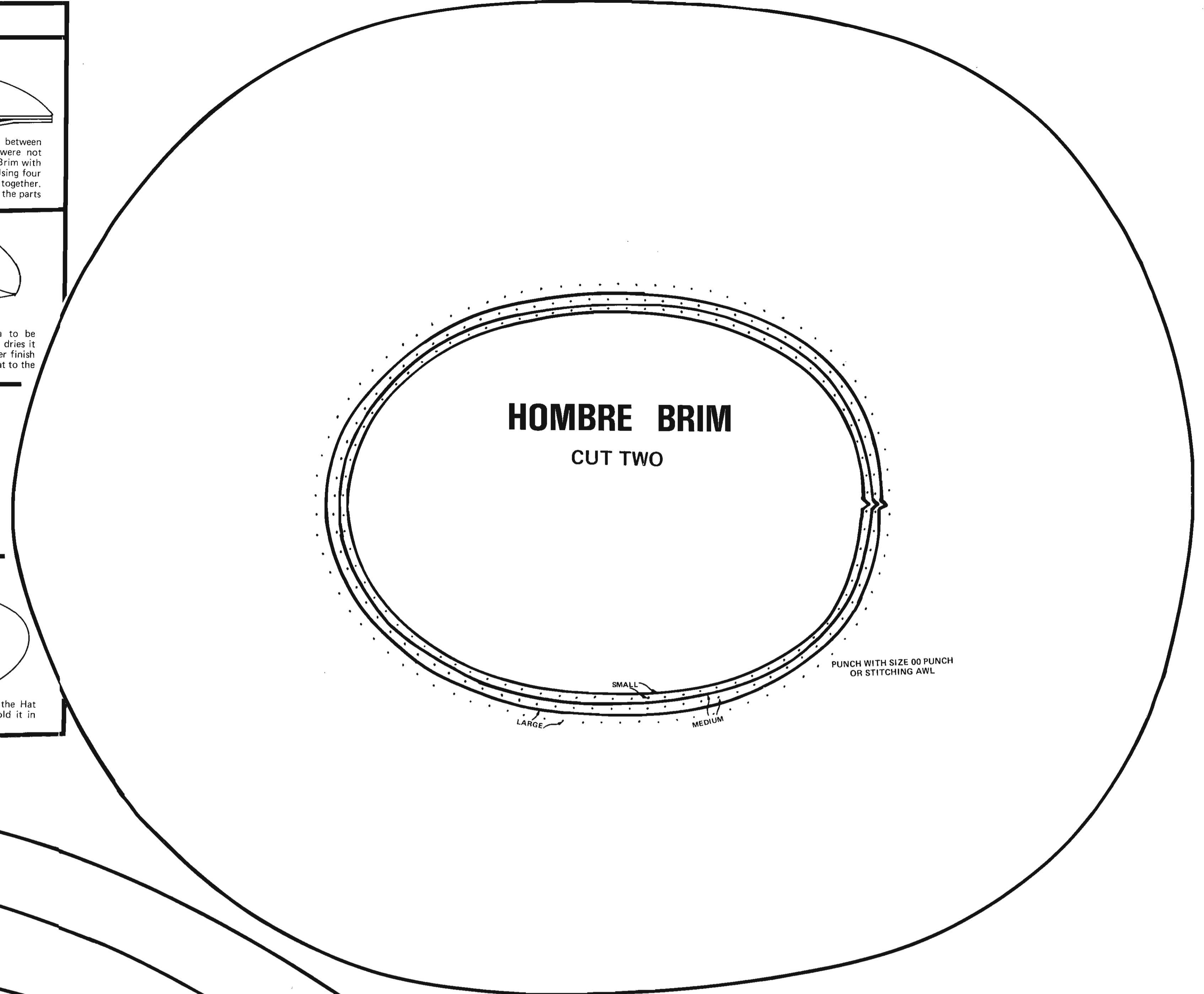

©Copyright 2010 by Tandy Leather Factory
 All Rights Reserved

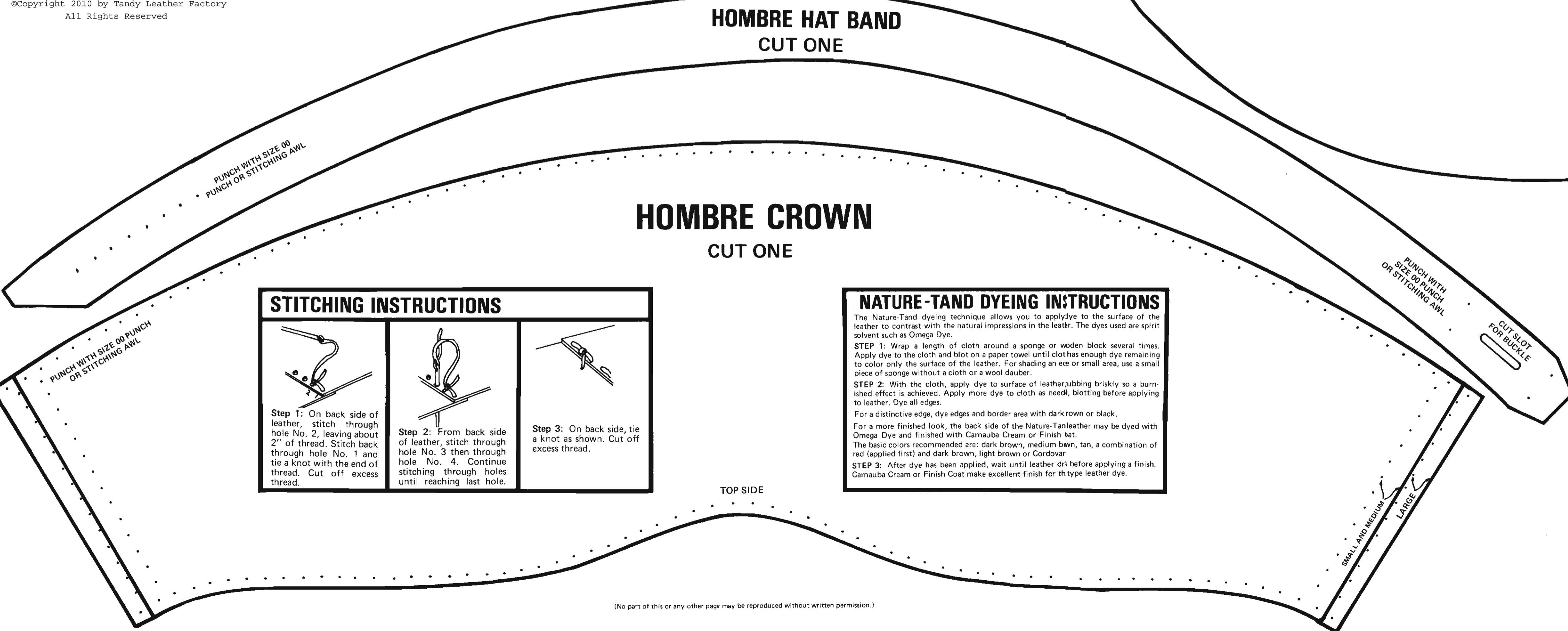

STITCHING INSTRUCTIONS

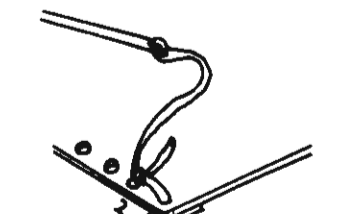
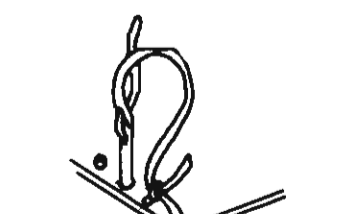
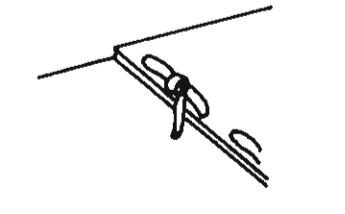
 <p>Step 1: On back side of leather, stitch through hole No. 2, leaving about 2" of thread. Stitch back through hole No. 1 and tie a knot with the end of thread. Cut off excess thread.</p>	 <p>Step 2: From back side of leather, stitch through hole No. 3 then through hole No. 4. Continue stitching through holes until reaching last hole.</p>	 <p>Step 3: On back side, tie a knot as shown. Cut off excess thread.</p>
--	--	---

NATURE-TAND DYEING INSTRUCTIONS

The Nature-Tand dyeing technique allows you to apply dye to the surface of the leather to contrast with the natural impressions in the leather. The dyes used are spirit solvent such as Omega Dye.

STEP 1: Wrap a length of cloth around a sponge or wooden block several times. Apply dye to the cloth and blot on a paper towel until cloth has enough dye remaining to color only the surface of the leather. For shading an edge or small area, use a small piece of sponge without a cloth or a wool dauber.

STEP 2: With the cloth, apply dye to surface of leather, rubbing briskly so a burnished effect is achieved. Apply more dye to cloth as needed, blotting before applying to leather. Dye all edges.

For a distinctive edge, dye edges and border area with dark brown or black.

For a more finished look, the back side of the Nature-Tan leather may be dyed with Omega Dye and finished with Carnauba Cream or Finish Coat.

The basic colors recommended are: dark brown, medium brown, tan, a combination of red (applied first) and dark brown, light brown or Cordovan.

STEP 3: After dye has been applied, wait until leather dries before applying a finish. Carnauba Cream or Finish Coat make excellent finish for th type leather dye.

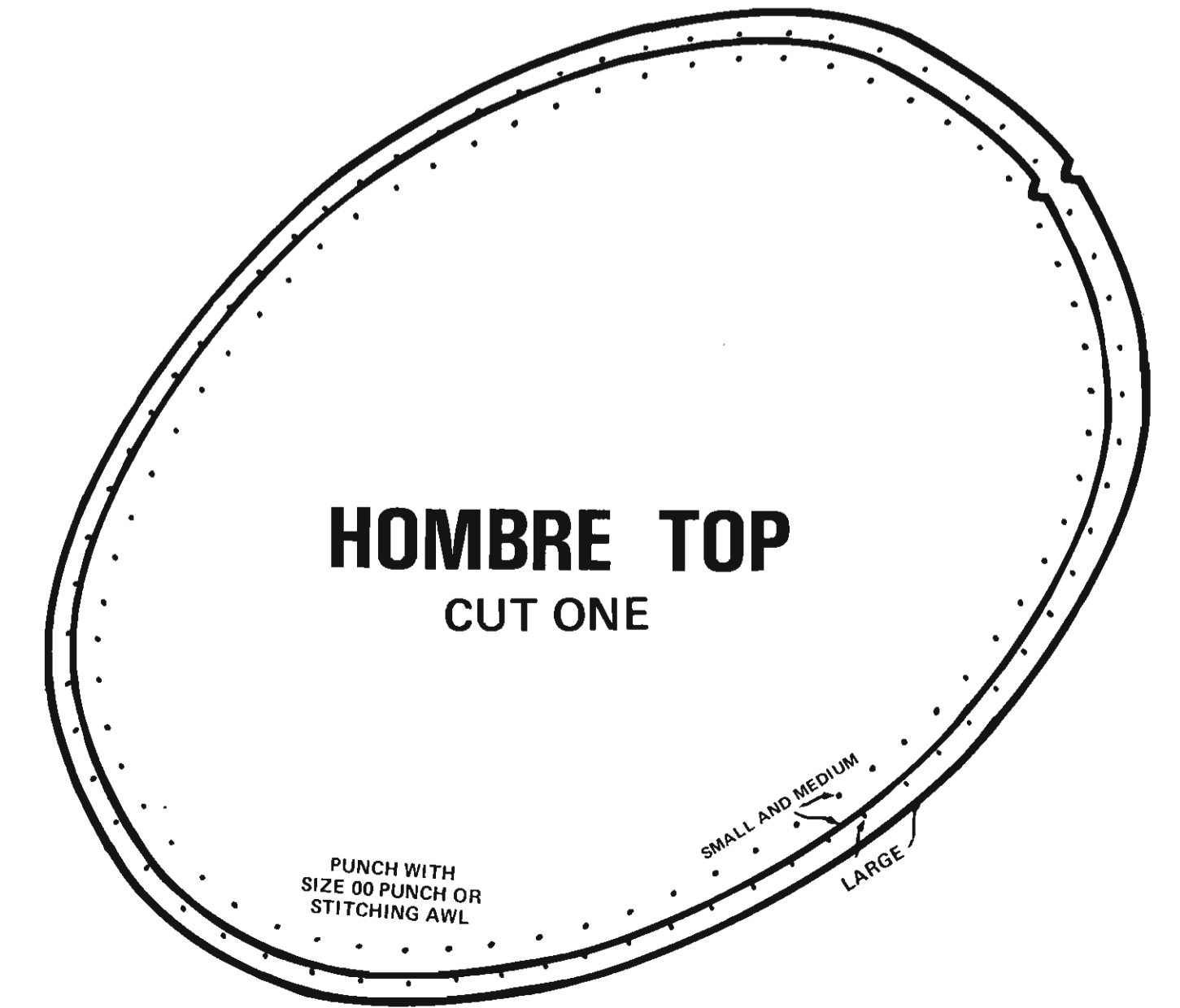

(No part of this or any other page may be reproduced without written permission.)

©Copyright 2010 by Tandy Leather Factory
All Rights Reserved

HOMBRE 1 PATTER

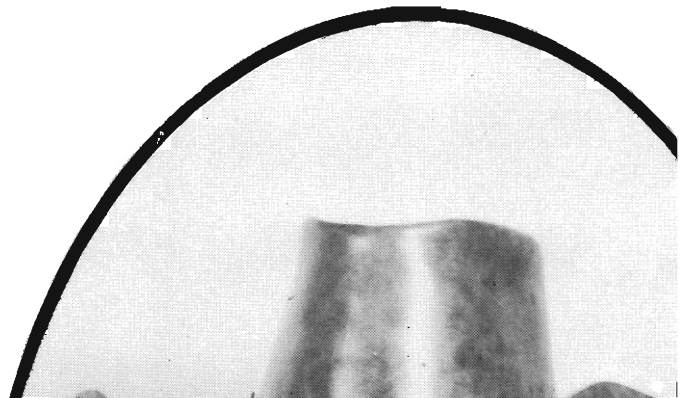

HAT

N

ASSEMBLY INSTR

Step 1:

Use the cutting patterns to cut the leather parts and punch the stitch holes. Dye the leather parts.

Use this chart to determine your hat size:

SIZE	HEAD MEASUREMENT
Small	21" to 22"
Medium	22 1/4" to 23"
Large	23 1/4" to 24"

Upon completion of your hat, if it is slightly small, use water to moisten the inside area of the hat, and push it down over your head in place. Wear it until it dries, and it will adjust to your size.

Step 5:

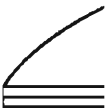

Insert the t...
cemer...
the rc...
feet...
Lightl...
with v...

Step 2:

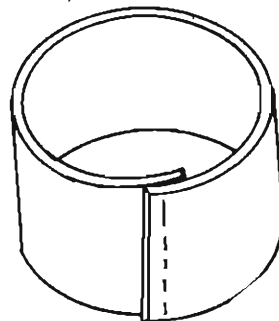

Using one foot of waxed thread, overlap the ends of the Crown Panel, align the holes and stitch along the holes following the Stitching Instructions.

Step 6:



Lightly formed...
will ret...
such as...
leather...

INSTRUCTIONS

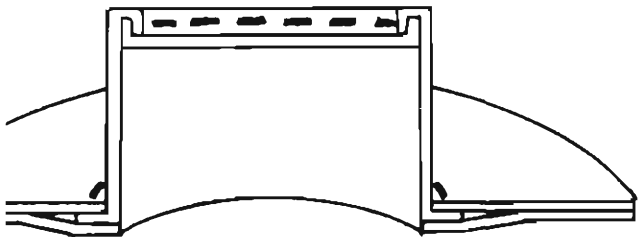

Stitch the bottom side of the Crown Panel between two inside edges of the Brim that were not stitched together. Align the notch in the Brim with the row of stitching in the Crown Panel. Using four strands of waxed thread, stitch the parts together. Soaking and dampening and forming the edges of the parts with water will make assembly easier.

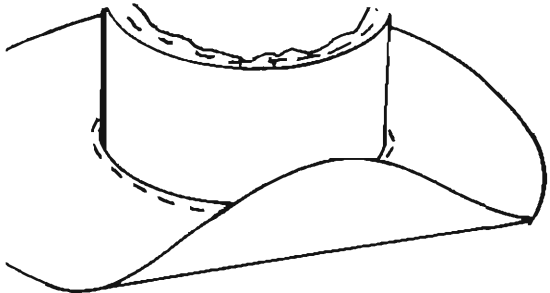

Soak and dampen with water the Brim area to be shaped, then shape as desired. As the Brim dries it will retain the shape formed. Apply a leather finish such as Omega Carnauba Cream or Finish Coat to the

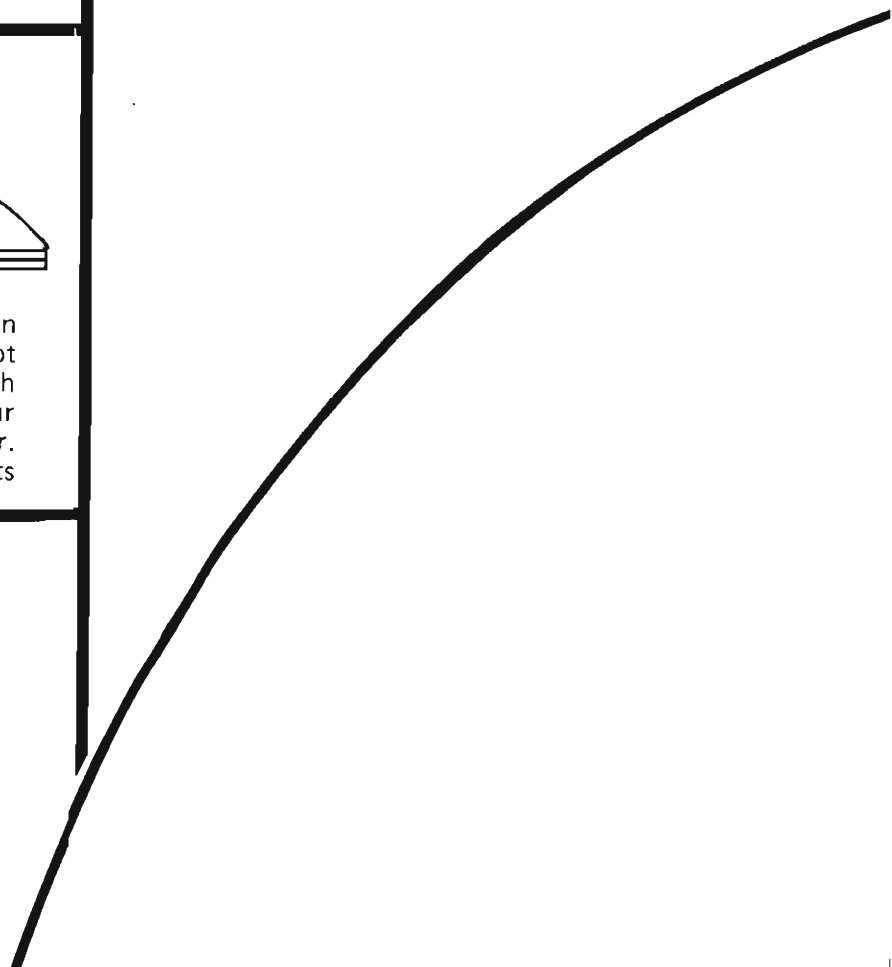

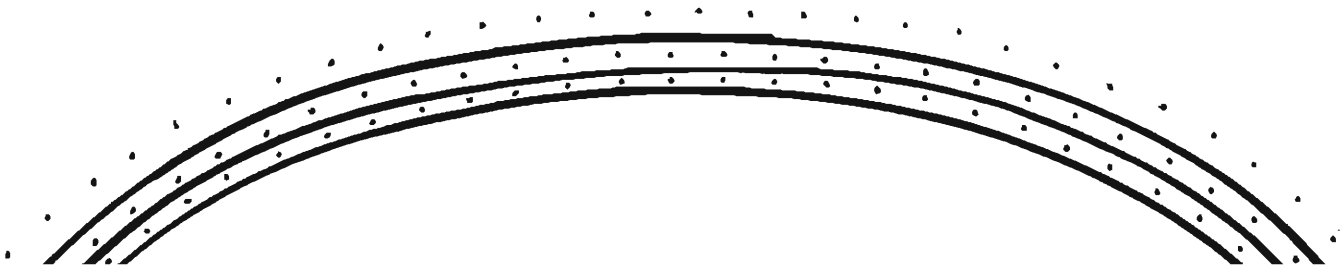

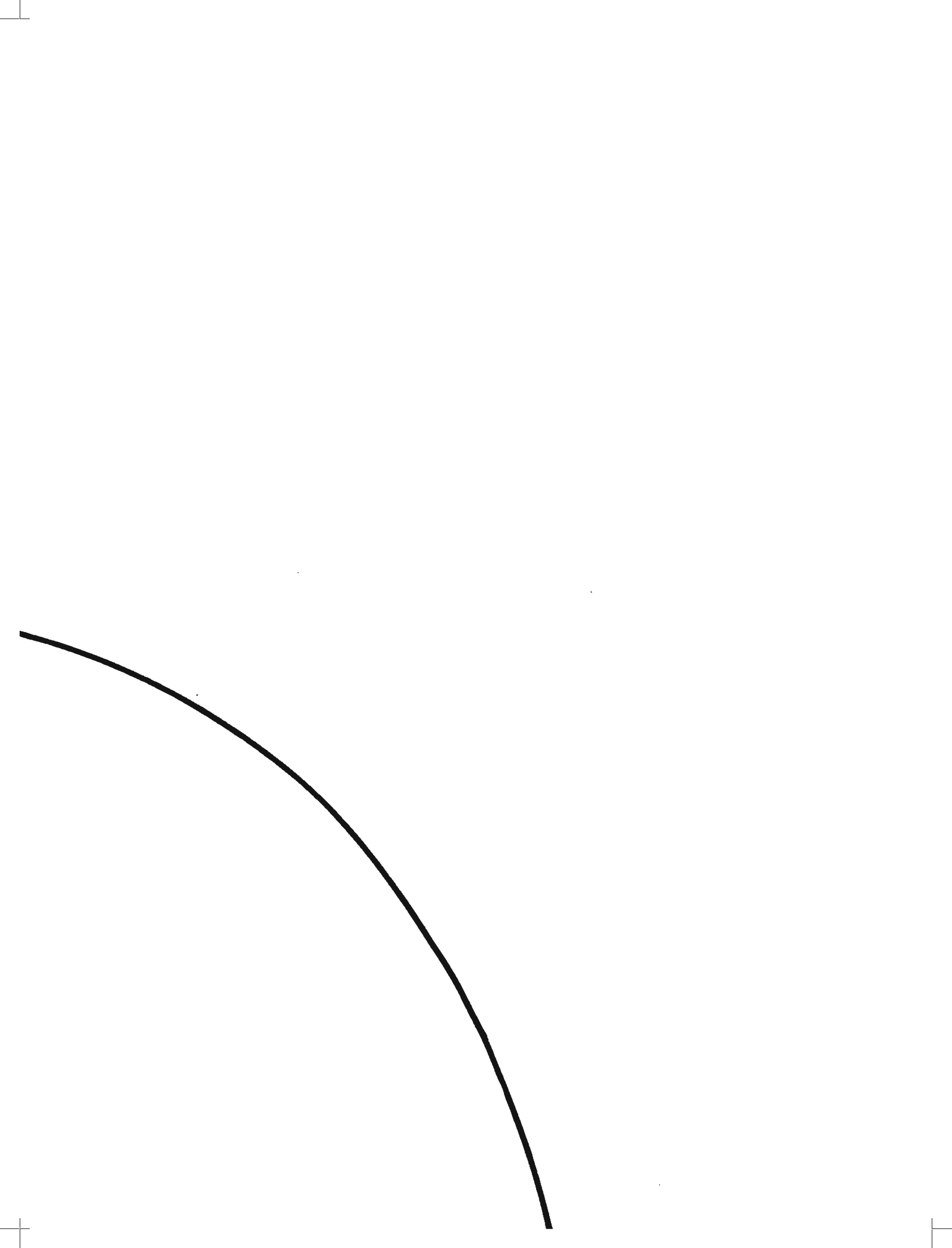

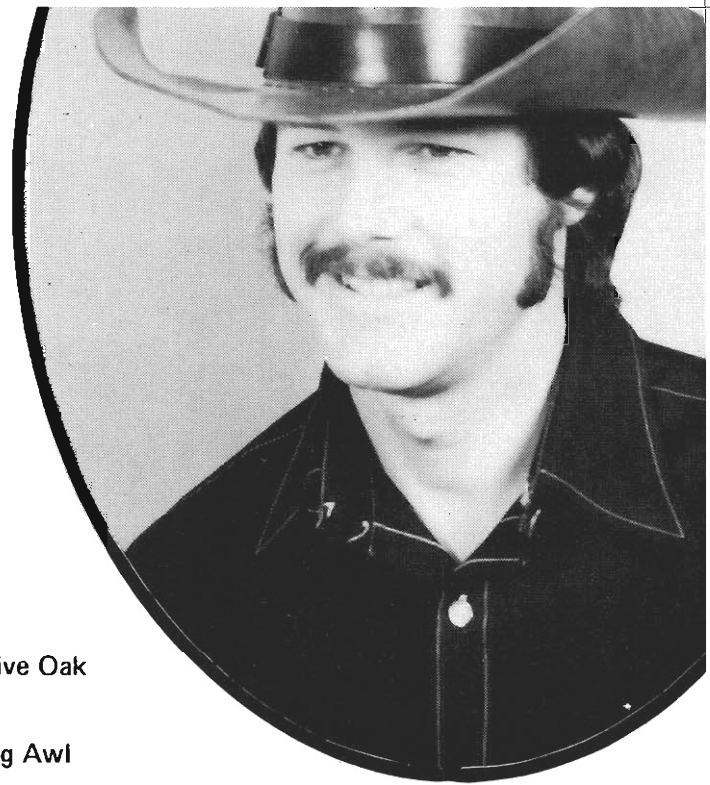

Materials Needed:

4-5 oz. Nature-Tand or Live Oak
10 feet Waxed Thread
Harness Needle Size 000
Punch Size 00 or Stitching Awl
Knife
Buckle 1"
Craftsman Cement
Omega Dye
Omega Carnauba Cream or Finish Coat

PUNCH WITH SIZE 00
PUNCH OR STITCHING AWL

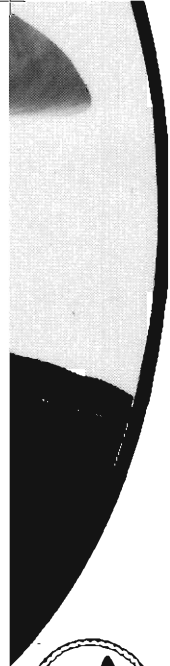

tandy
LEATHER COMPANY

T C A TANDY CORPORATION COMPANY

Distributed by
TANDY WAREHOUSE COMPANY
Fort Worth, Texas 76107

Step 3:

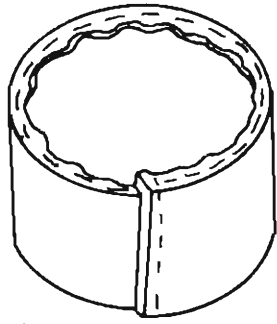

Using four feet of waxed thread, stitch the Top to the top side of the Crown Panel. Align the notch in the Top with the row of stitching in the Crown Panel. Lightly dampening and forming the edges of the parts with water will make assembly easier.

Step 7:



Attach waxed

Step 4:

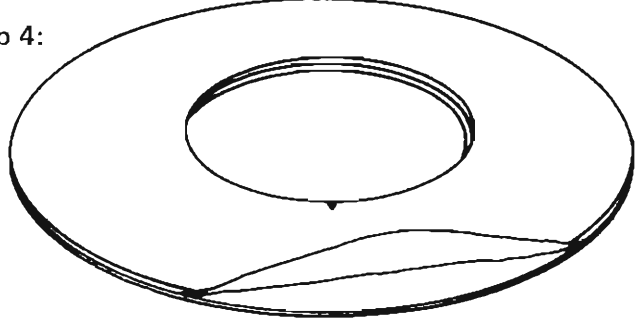

Cement the two Brim parts together with Craftsman Cement, flesh side to flesh side, with the stitching holes aligned. Leave 1/2" not cemented on the inside edge.

Step 8:



Buckle Band (place.

HOMBRE HAT
CUT ONE

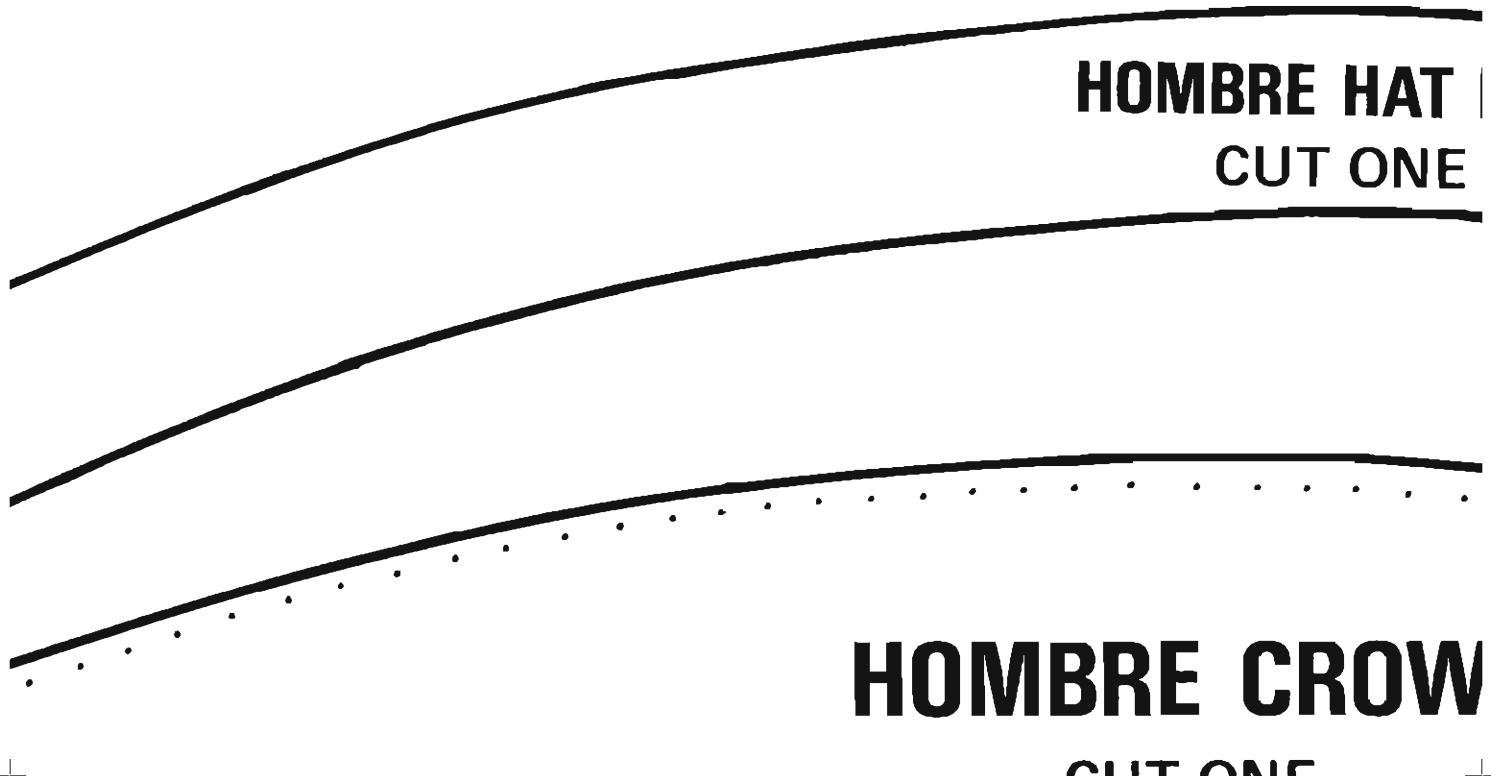

HOMBRE CROW
CUT ONE

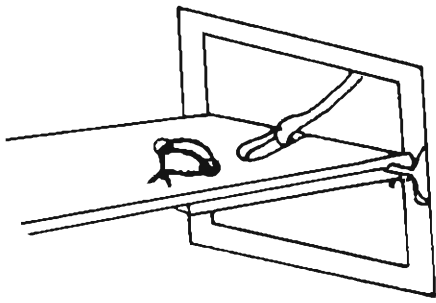

the buckle to the Hat Band with thread.

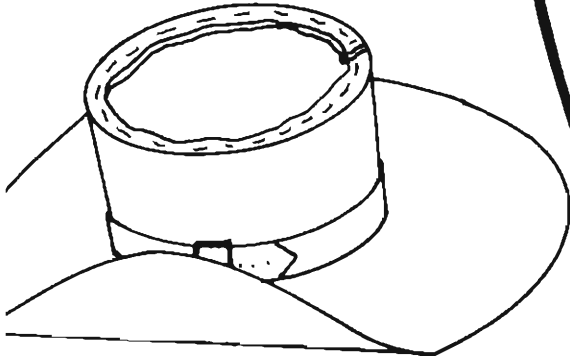

the Hat Band in place. If needed, the Hat can be cemented to the crown to hold it in

BAND

N

HOMBRE BRIM

CUT TWO

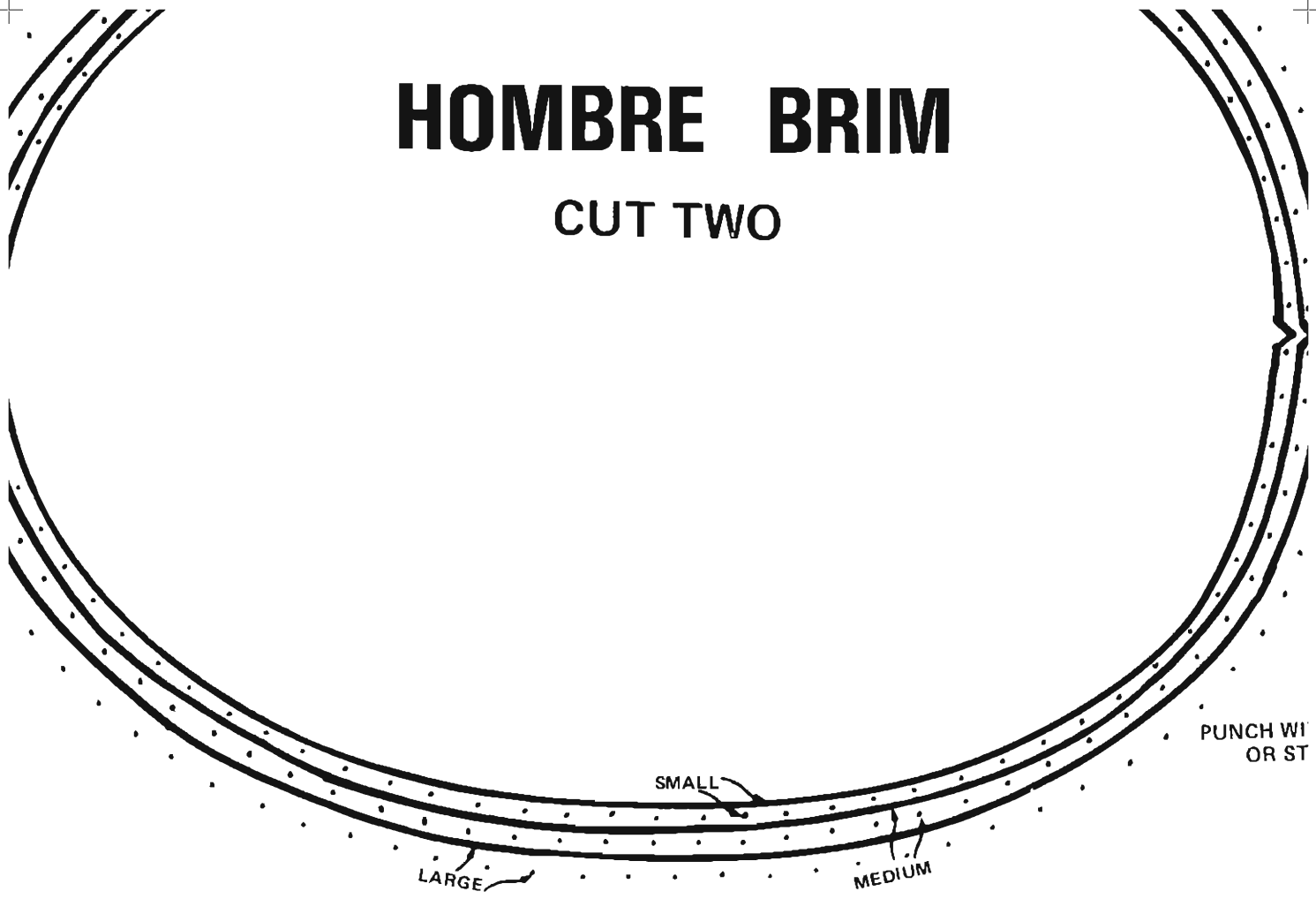

PUNCH W/
OR ST

SMALL

LARGE

MEDIUM





TH SIZE 00 PUNCH
ITCHING AWL

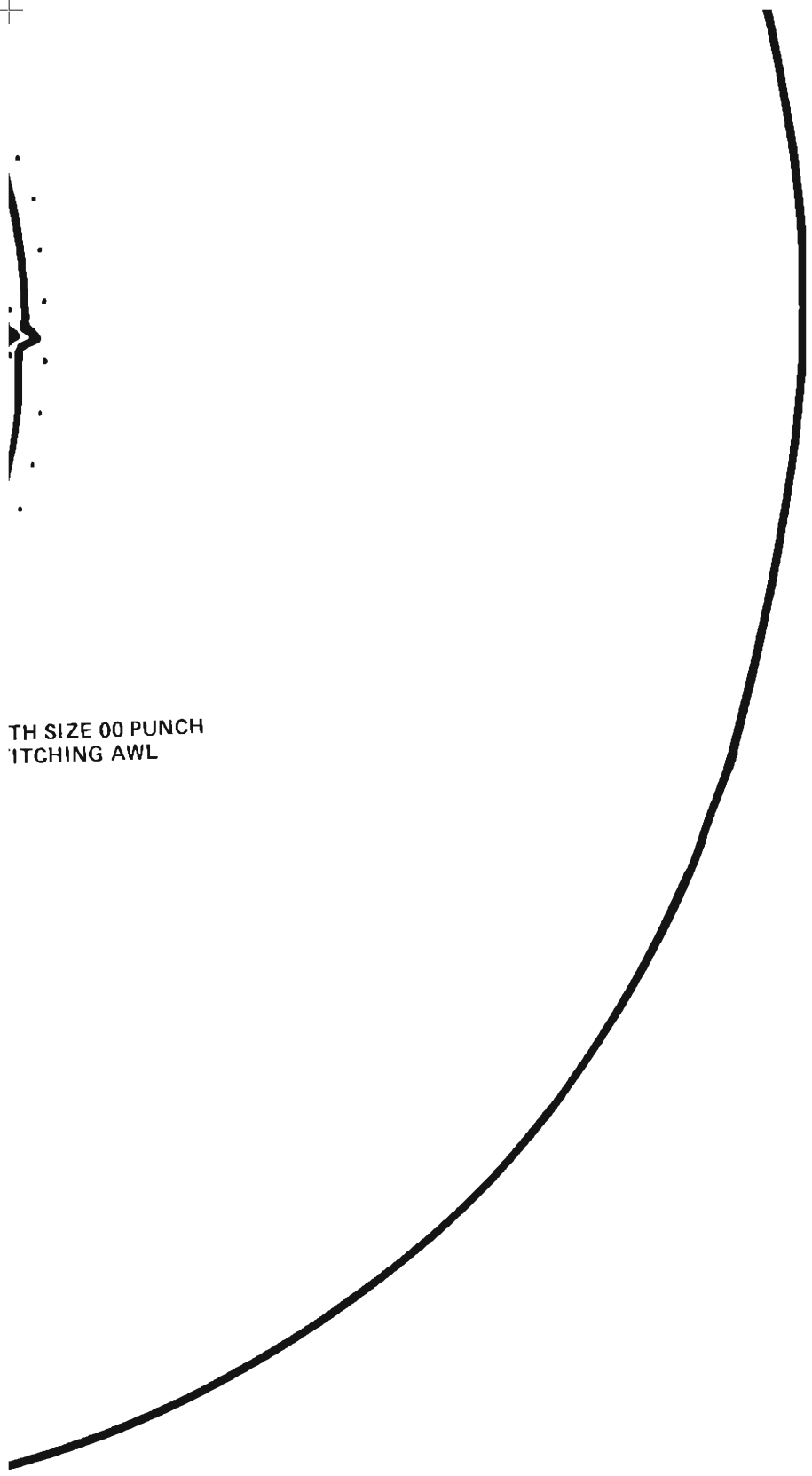

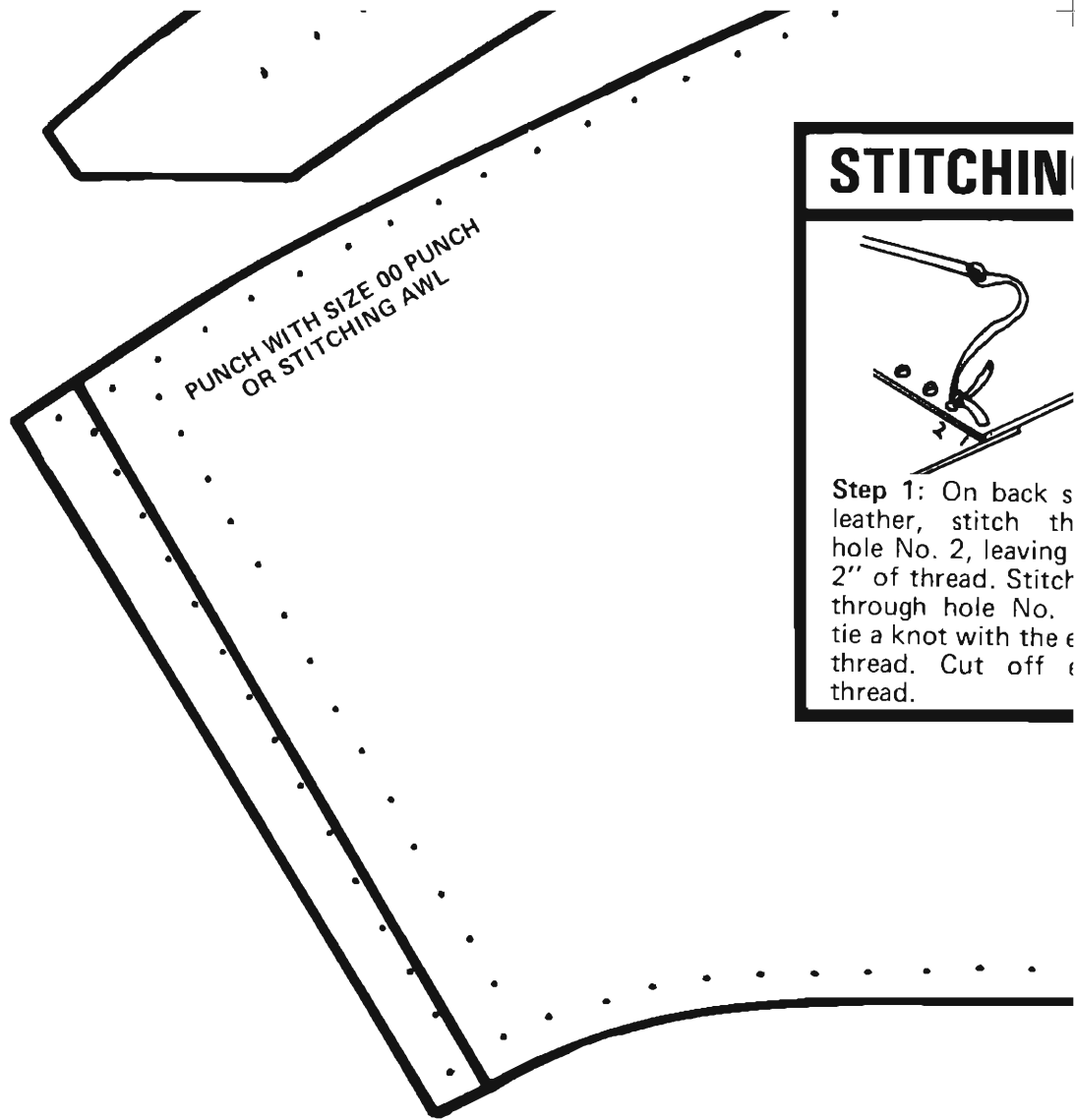

PUNCH WITH SIZE 00 PUNCH
OR STITCHING AWL

STITCHING

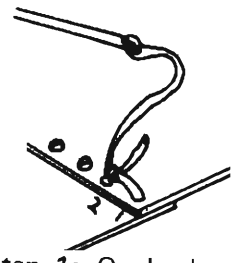

Step 1: On back of leather, stitch through hole No. 2, leaving 2" of thread. Stitch through hole No. 1, tie a knot with the end of thread. Cut off excess thread.

G INSTRUCTIONS

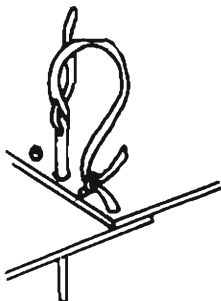

Step 2: From back side of leather, stitch through hole No. 3 then through hole No. 4. Continue stitching through holes until reaching last hole.

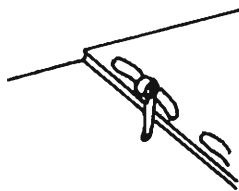

Step 3: On back side, tie a knot as shown. Cut off excess thread.

side of
rough
about
back
1 and
end of
excess

TOP SIDE

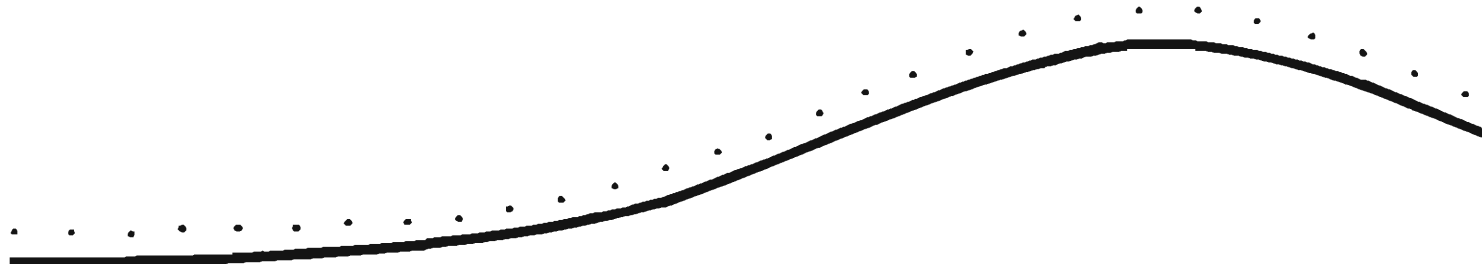

(No part of this or any other page may be reproduced without written permission)

NATURE-TAN DYEING INSTRUCTIONS

The Nature-Tan dyeing technique allows you to apply dye to the surface of the leather to contrast with the natural impressions in the leather. The dyes used are spirit solvent such as Omega Dye.

STEP 1: Wrap a length of cloth around a sponge or wooden block several times. Apply dye to the cloth and blot on a paper towel until cloth has enough dye remaining to color only the surface of the leather. For shading an edge or small area, use a small piece of sponge without a cloth or a wool dauber.

STEP 2: With the cloth, apply dye to surface of leather, rubbing briskly so a burnished effect is achieved. Apply more dye to cloth as needed, blotting before applying to leather. Dye all edges.

For a distinctive edge, dye edges and border area with dark brown or black.

For a more finished look, the back side of the Nature-Tan leather may be dyed with Omega Dye and finished with Carnauba Cream or Finish Sat.

The basic colors recommended are: dark brown, medium brown, tan, a combination of red (applied first) and dark brown, light brown or Cordovar

STEP 3: After dye has been applied, wait until leather dries before applying a finish. Carnauba Cream or Finish Coat make excellent finish for this type leather dye.

mission.)

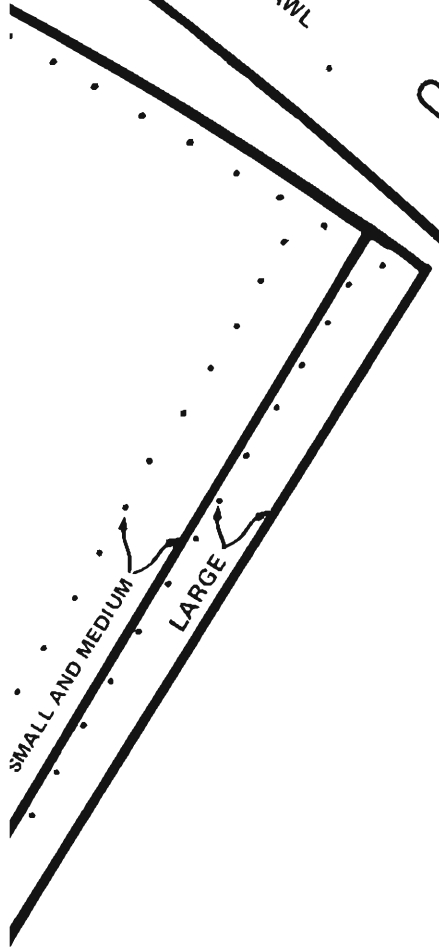
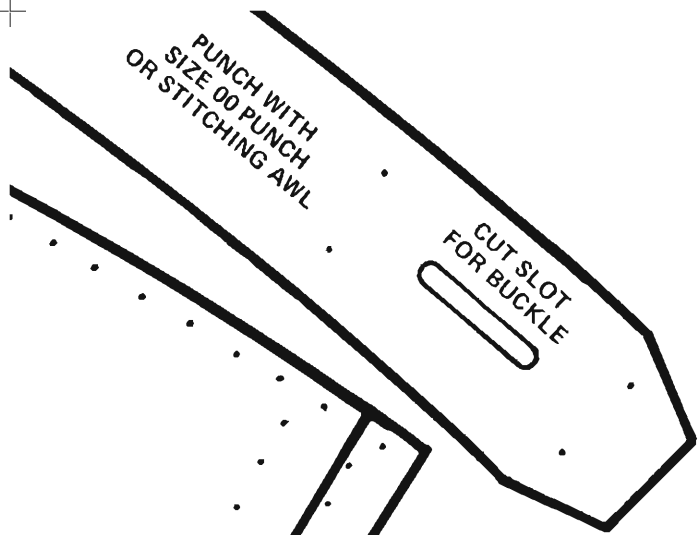

MBRE TOP

CUT ONE

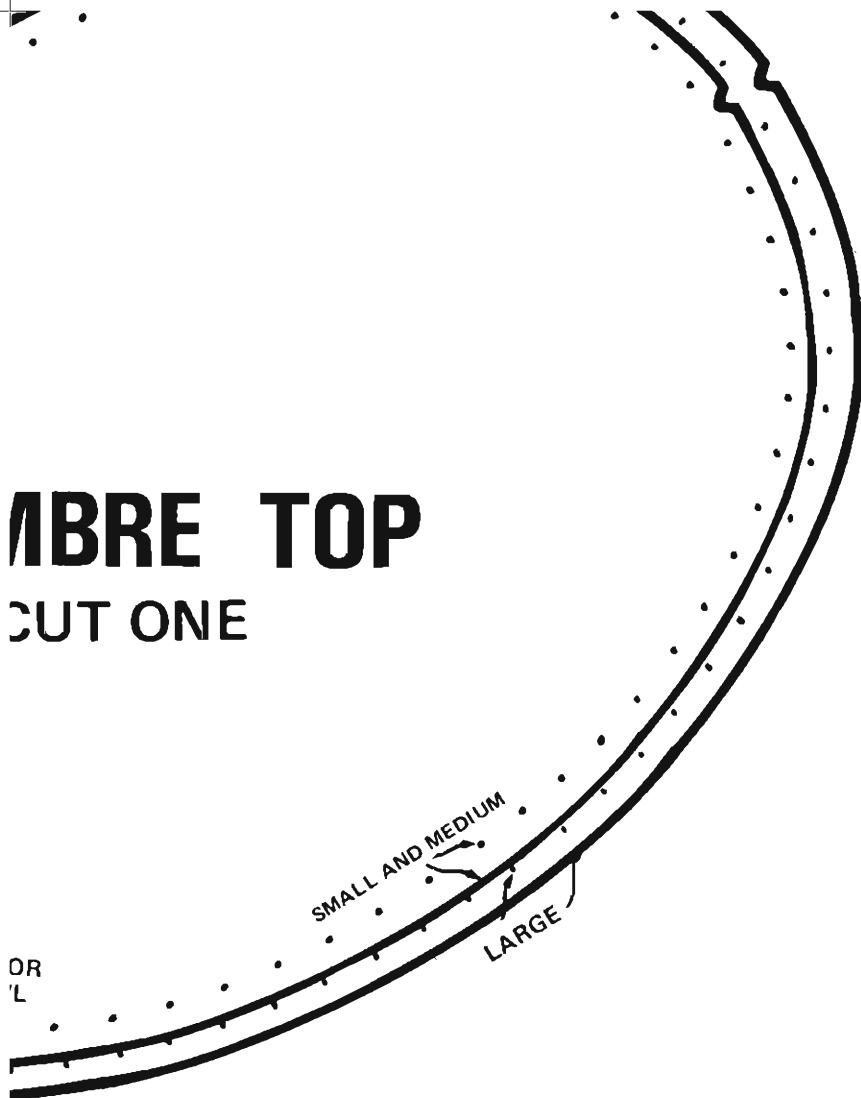

MAVERICK HAT PATTERN



MATERIALS NEEDED:
 4-5 oz. Nature-Tan or Live Oak
 4 yds. 1/8" Indian Tan Lace
 Latigo Life-Eye Lacing Needle
 Punch Size 3
 Knife
 Craftsman Cement
 Omega Dye
 Omega Carnauba Cream or Finish Coat



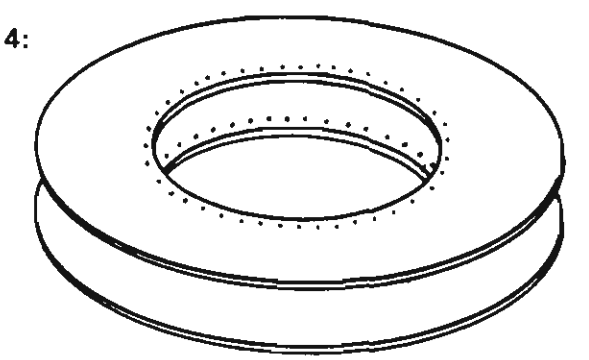
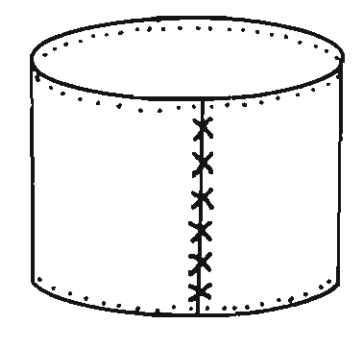
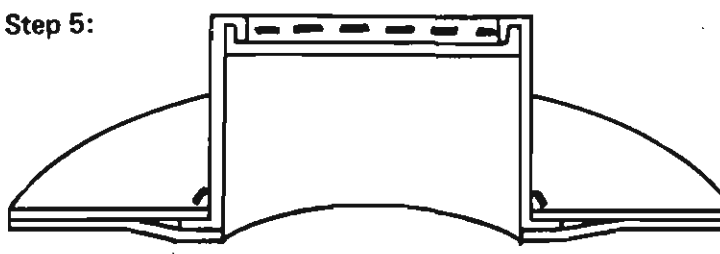
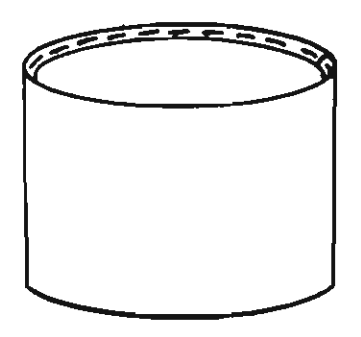
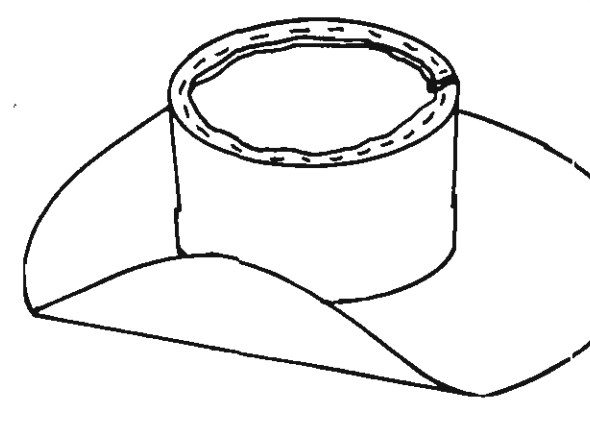

Distributed by
TANDY WAREHOUSE COMPANY
 Fort Worth, Tex. 76107

ASSEMBLY INSTRUCTIONS

<p>Step 1: Use the cutting patterns to cut the leather parts and punch the lacing holes.</p> <p>Use this chart to determine your hat size:</p> <table border="1"> <thead> <tr> <th>SIZE</th> <th>HEAD MEASUREMENT</th> </tr> </thead> <tbody> <tr> <td>Small</td> <td>21" to 22"</td> </tr> <tr> <td>Medium</td> <td>22 1/4" to 23"</td> </tr> <tr> <td>Large</td> <td>23 1/4" to 24"</td> </tr> </tbody> </table> <p>Upon completion of your hat, if it is slightly small, use water to moisten the inside area of the hat, and push it down over your head in place. Wear it until it dries, and it will adjust to your size.</p>	SIZE	HEAD MEASUREMENT	Small	21" to 22"	Medium	22 1/4" to 23"	Large	23 1/4" to 24"	<p>Step 4:</p>  <p>Cement the two Brim parts together with Craftsman Cement, flesh side to flesh side, with the lacing holes aligned. Leave 1/2" not cemented on the inside edge.</p>
SIZE	HEAD MEASUREMENT								
Small	21" to 22"								
Medium	22 1/4" to 23"								
Large	23 1/4" to 24"								
<p>Step 2:</p>  <p>Beginning with the second hole, lace the ends of the Crown Panel together with two feet of lace following the Cross Stitch Lacing Instructions. Do not lace through the bottom holes.</p>	<p>Step 5:</p>  <p>Insert the bottom side of the Crown Panel between the two inside edges of the Brim that were not cemented together. Align the notch in the Brim with the seam where the Crown Panel is joined together. With the lacing holes aligned, lace the parts together with four feet of lace with a Running Stitch. Lightly dampening and forming the edges of the parts with water will make assembly easier.</p>								
<p>Step 3:</p>  <p>Lace the Top to the top side of the Crown Panel with four feet of lace following the Running Stitch Lacing Instructions. Align the notch in the Top with the seam of the Crown Panel. Lightly dampening and forming the edges of the parts with water will make assembly easier.</p>	<p>Step 6:</p>  <p>Lightly dampen with water the Brim area to be formed, then shape as desired. As the Brim dries it will retain the shape formed. Apply a leather finish such as Omega Carnauba Cream or Finish Coat to the leather.</p>								

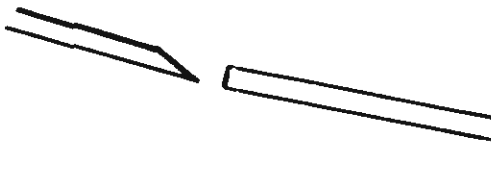
RUNNING STITCH LACING INSTRUCTIONS

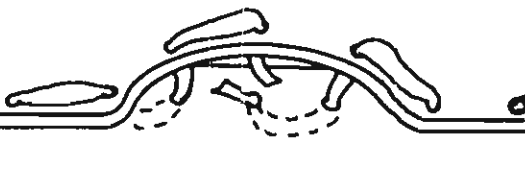
<p>Step 1: Insert one end of the 1/8" Indian Tan Lace in the Latigo Life-Eye Lacing Needle.</p> 	<p>Step 2: Begin lacing in between the two leathers, leaving a very short end.</p> 	<p>Step 3: Lace the parts together with a Running Stitch as shown. Lace to the last hole.</p> 	<p>Step 4: Pull the lace out between the two leathers and cut off the excess lace. Cement the ends in place between the leathers with Craftsman Cement.</p> 
--	--	--	--

CROSS STITCH LACING INSTRUCTIONS

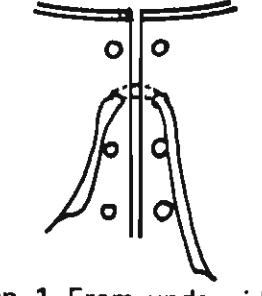
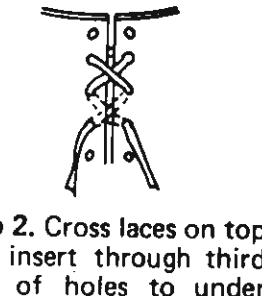
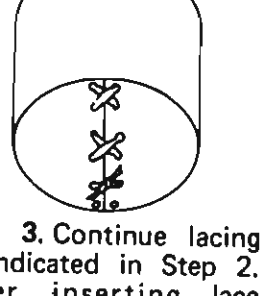
<p>Step 1: From under side of leather insert ends of lace up through second pair of holes to top side</p> 	<p>Step 2: Cross laces on top and insert through third pair of holes to under side. Cross lace on under side and insert up through fourth pair of holes to top.</p> 	<p>Step 3: Continue lacing as indicated in Step 2. After inserting lace through next to last pair of holes to under side of leather, tie or cement ends.</p> 
--	--	---

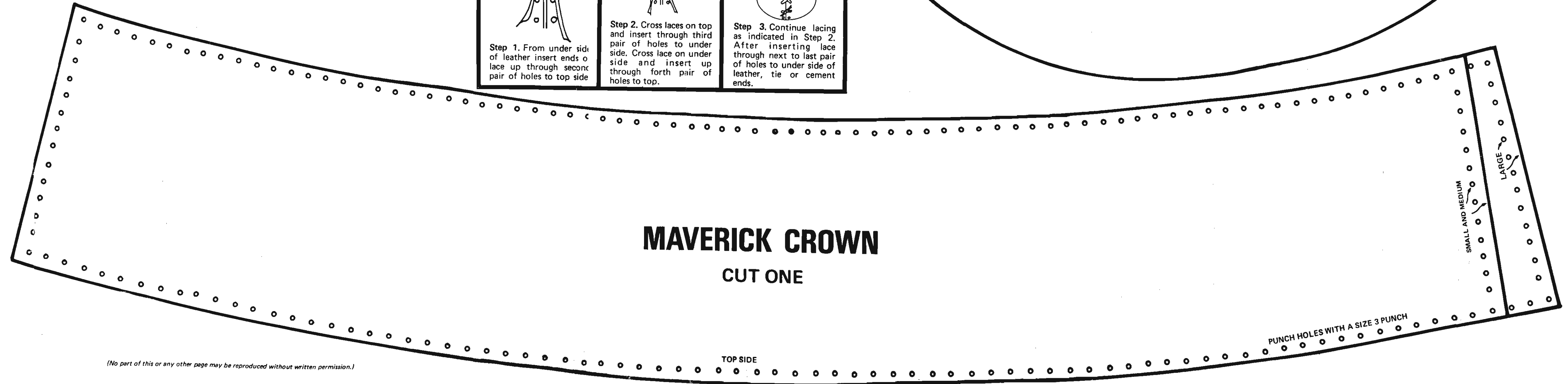
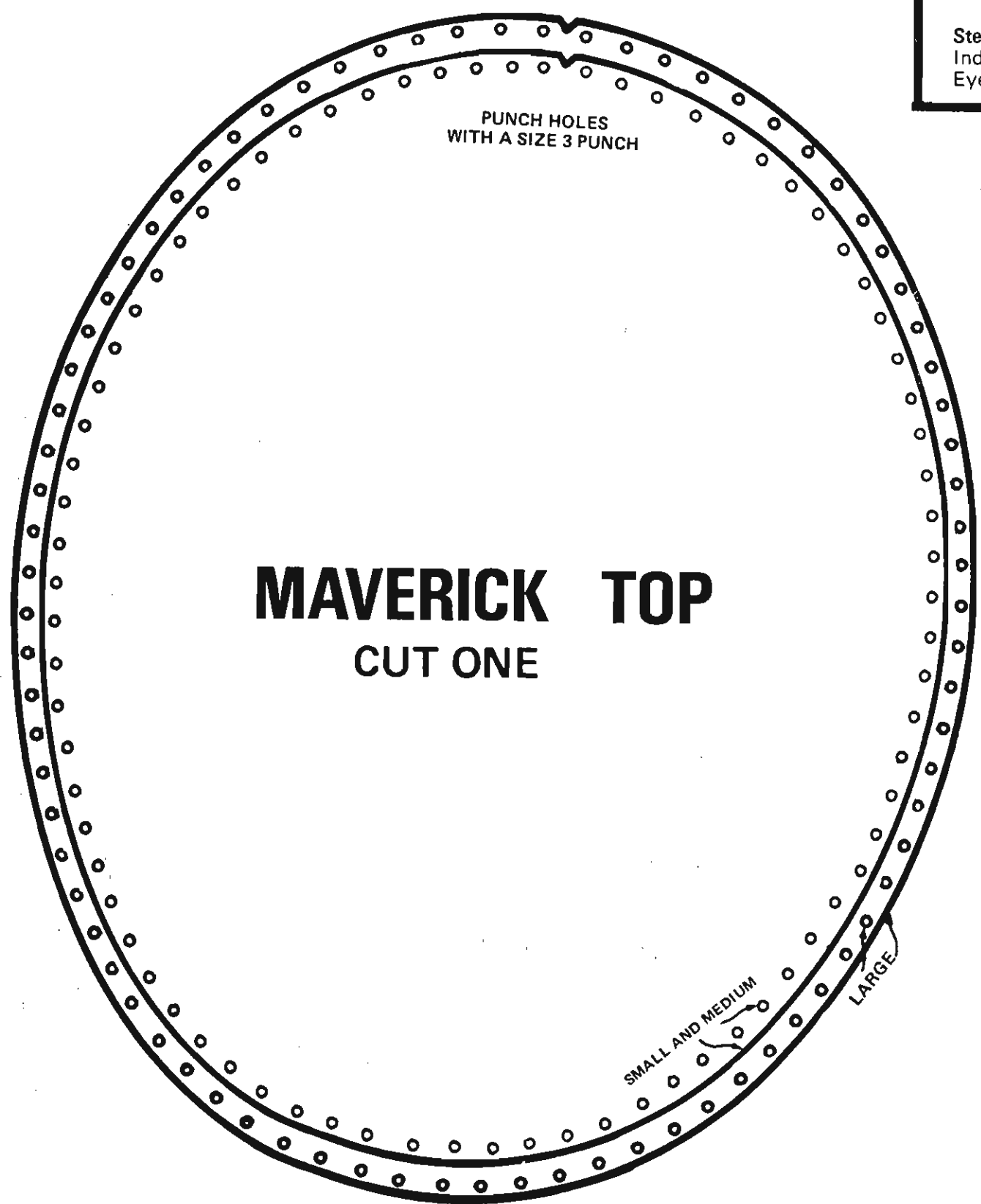
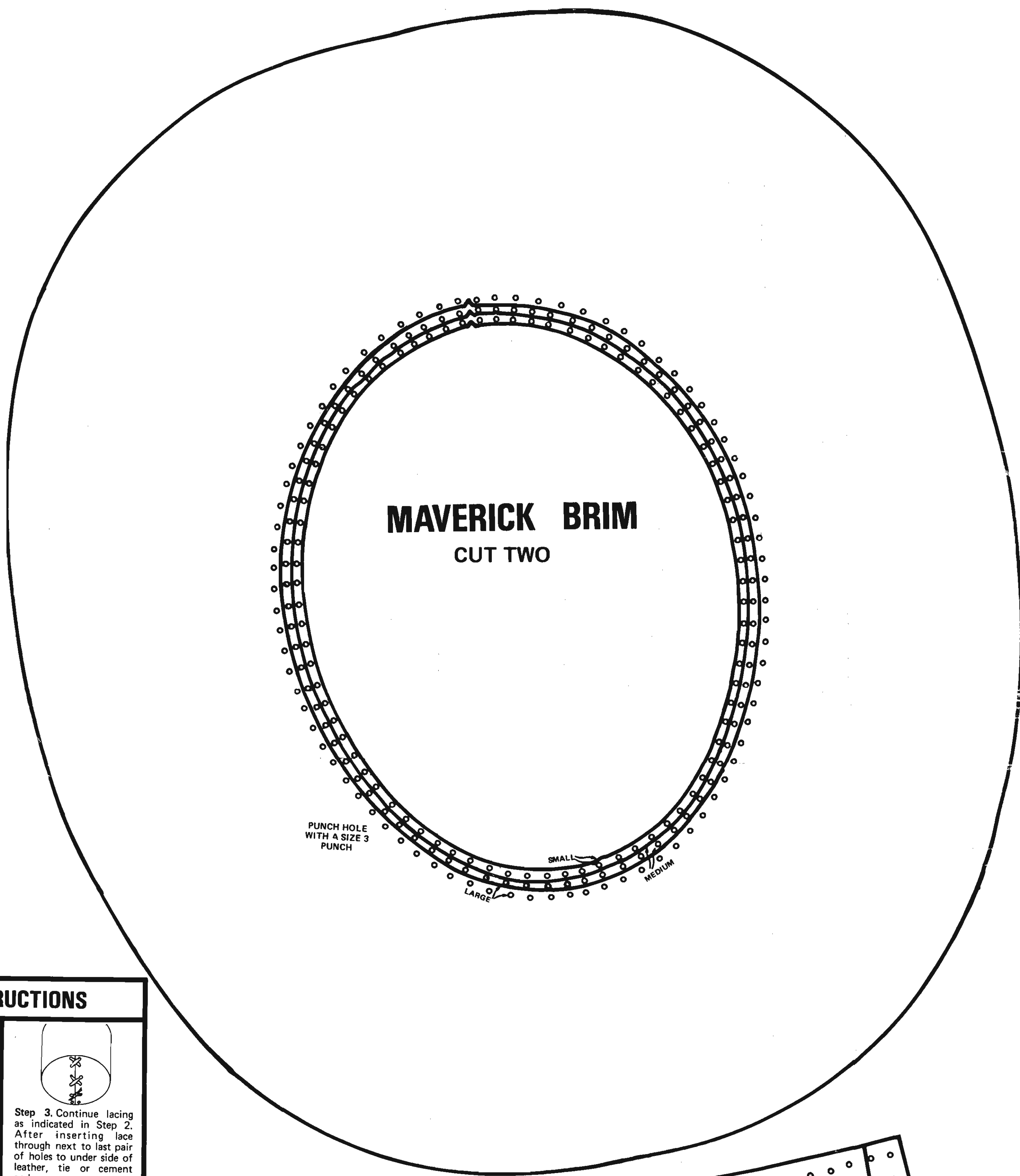

(No part of this or any other page may be reproduced without written permission.)

MAVERIC PATTE

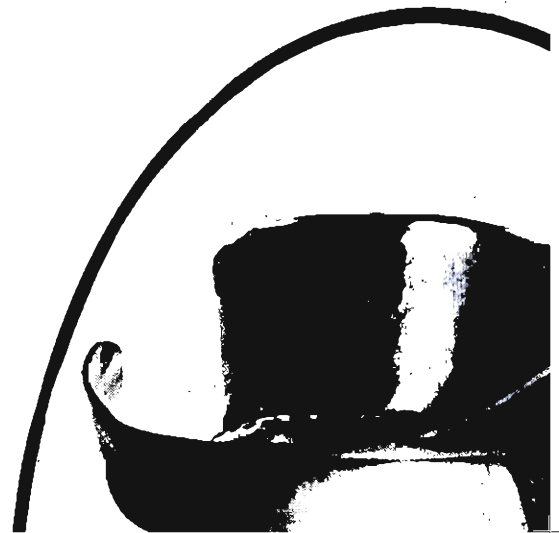

LEATHER HAT PATTERN



ASSEMBLY INSTRUCTIONS

Step 1:

Use the cutting patterns to cut the leather parts and punch the lacing holes.

Use this chart to determine your hat size:

SIZE	HEAD MEASUREMENT
Small	21" to 22"
Medium	22 1/4" to 23"
Large	23 1/4" to 24"

Upon completion of your hat, if it is slightly small, use water to moisten the inside area of the hat, and push it down over your head in place. Wear it until it dries, and it will adjust to your size.

Step 2:

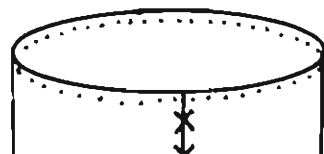

INSTRUCTIONS

Step 4:

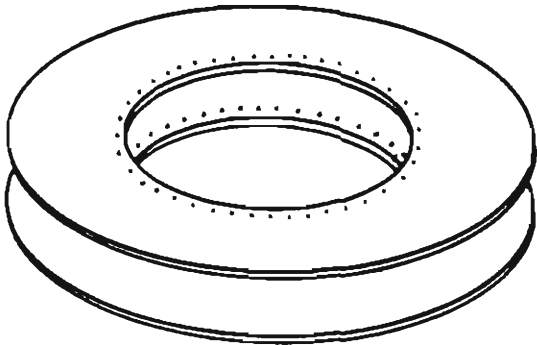

Cement the two Brim parts together with Craftsman Cement, flesh side to flesh side, with the lacing holes aligned. Leave 1/2" not cemented on the inside edge.

Step 5:

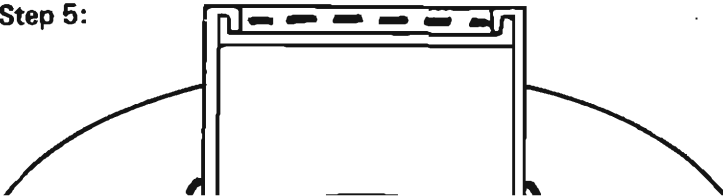

©Copyright 2010 by Tandy Leather Factory
All Rights Reserved

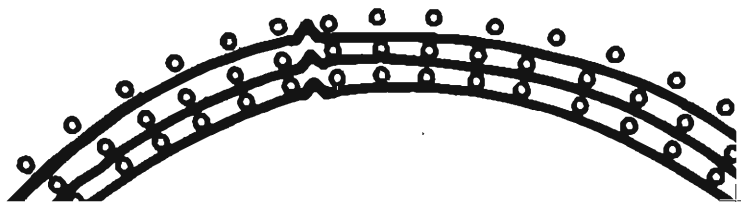

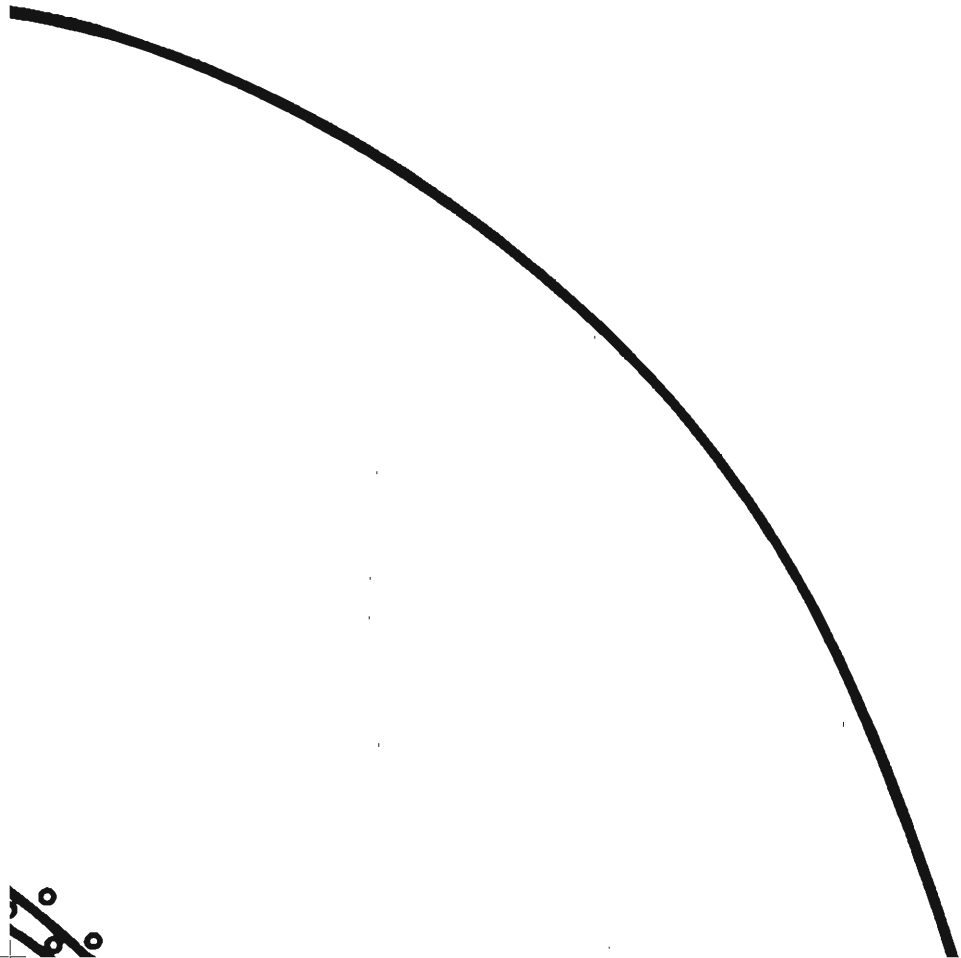



MATERIALS NEEDED:

4-5 oz. Nature-Tand or Live Oak

4 yds. 1/8" Indian Tan Lace

Latigo Life-Eye Lacing Needle

Punch Size 3

Knife

Craftsman Cement

Omega Dye

Omega Carnauba Cream or Finish Coat

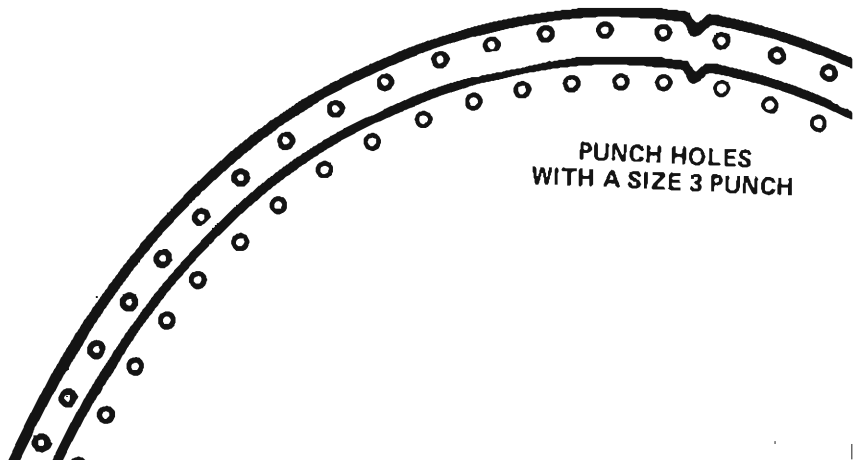



Distributed by
TANDY WAREHOUSE COMPANY
Fort Worth, Tex. 76107

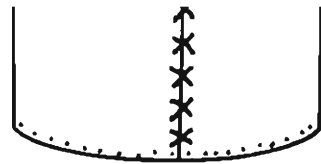

Beginning with the second hole, lace the ends of the Crown Panel together with two feet of lace following the Cross Stitch Lacing Instructions. Do not lace through the bottom holes.

Step 3:

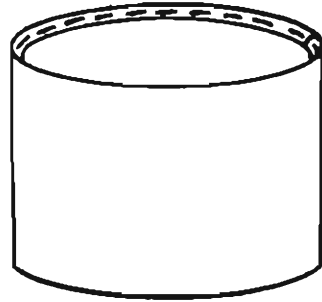

Lace the Top to the top side of the Crown Panel with four feet of lace following the Running Stitch Lacing Instructions. Align the notch in the Top with the seam of the Crown Panel. Lightly dampening and forming the edges of the parts with water will make assembly easier.

RUNNING STITCH LACING INSTRUCTIONS



Step 1: Insert one end of the 1/8" Indian Tan Lace in the Latigo Life-Eye Lacing Needle.



Step 2: Begin lacing in between the two leathers, leaving a very short end.

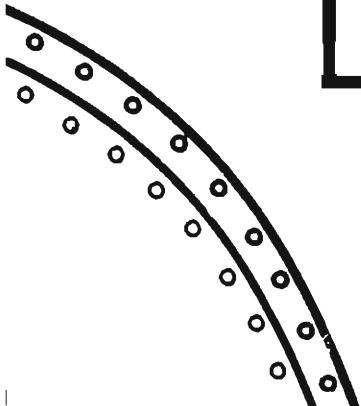



Insert the bottom side of the Crown Panel between the two inside edges of the Brim that were not cemented together. Align the notch in the Brim with the seam where the Crown Panel is joined together. With the lacing holes aligned, lace the parts together with four feet of lace with a Running Stitch. Lightly dampening and forming the edges of the parts with water will make assembly easier.

Step 6

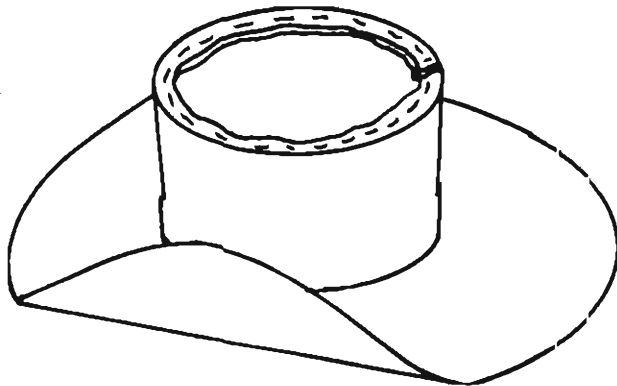

Lightly dampen with water the Brim area to be formed, then shape as desired. As the Brim dries it will retain the shape formed. Apply a leather finish such as Omega Carnuba Cream or Finish Coat to the leather.



Step 3: Lace the parts together with a Running Stitch as shown. Lace to the last hole.



Step 4: Pull the lace out between the two leathers and cut off the excess lace. Cement the ends in place between the leathers with Craftsman Cement.

CROSS STITCH LACING INSTRUCTIONS

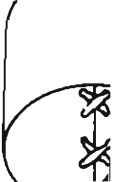
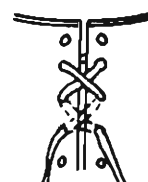
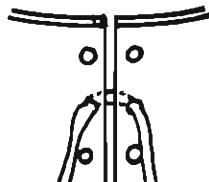

MAVERICK BRIN

CUT TWO

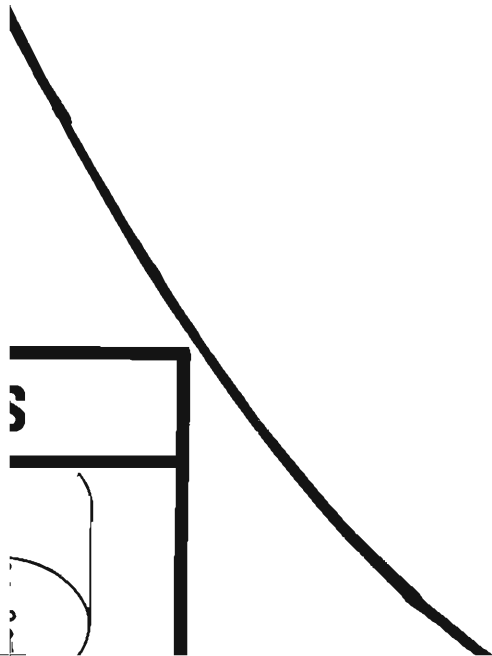
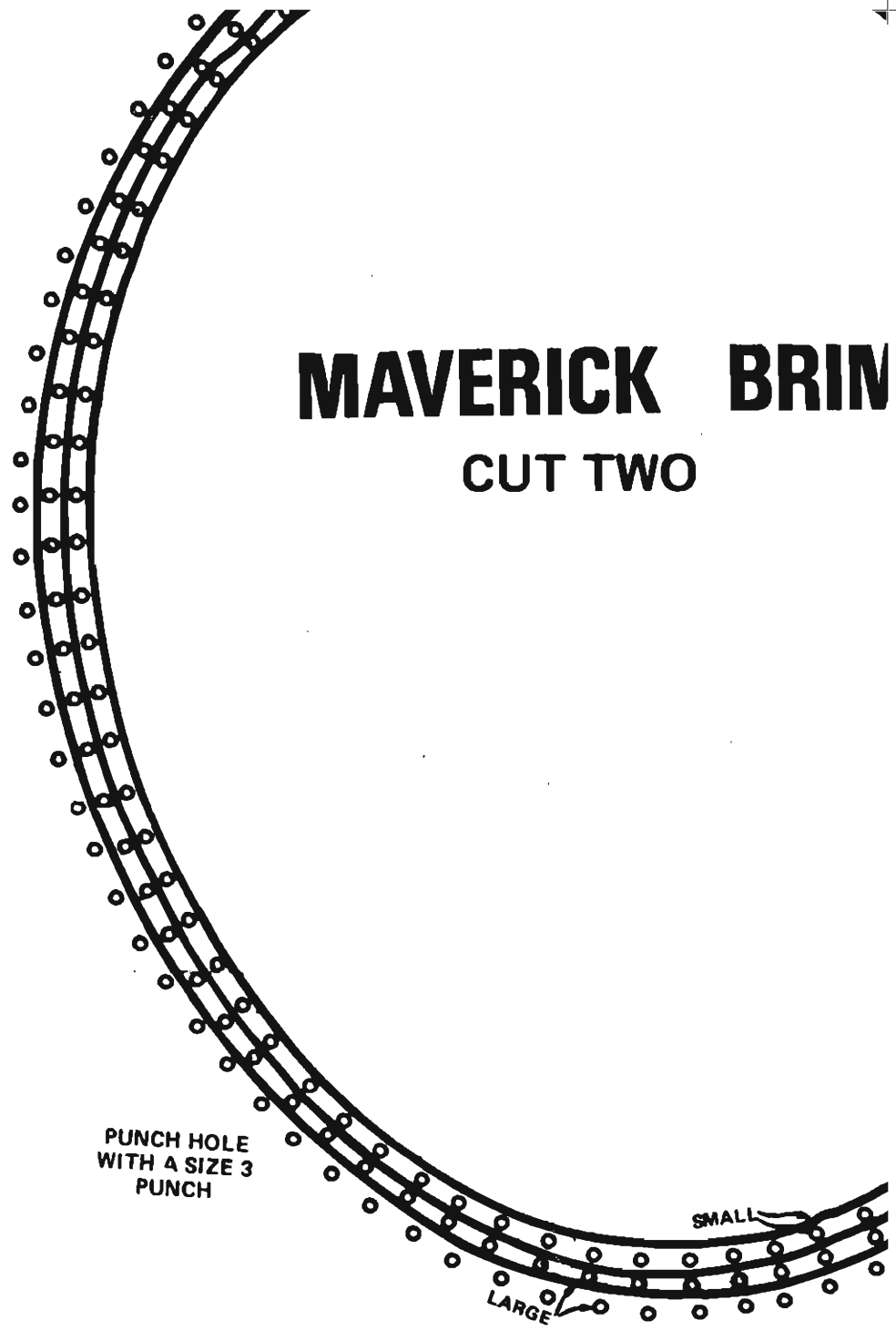

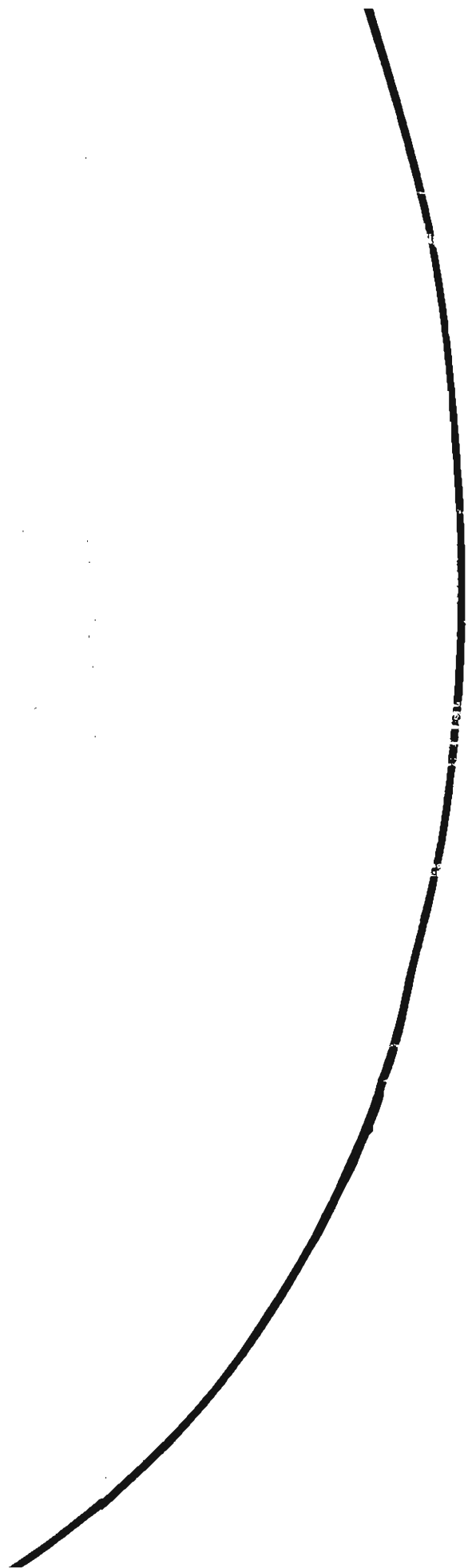
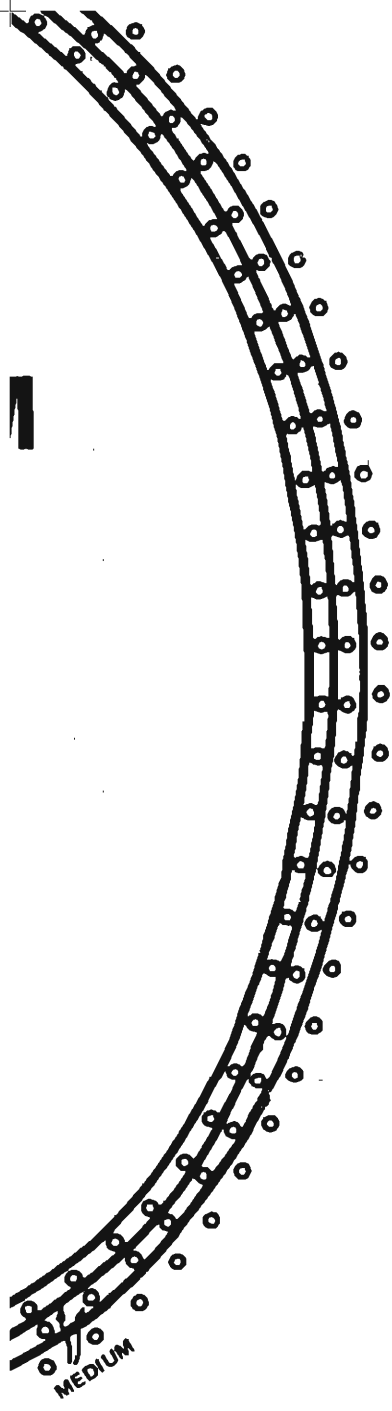

MEDIUM

MAVERICK TOI

CUT ONE

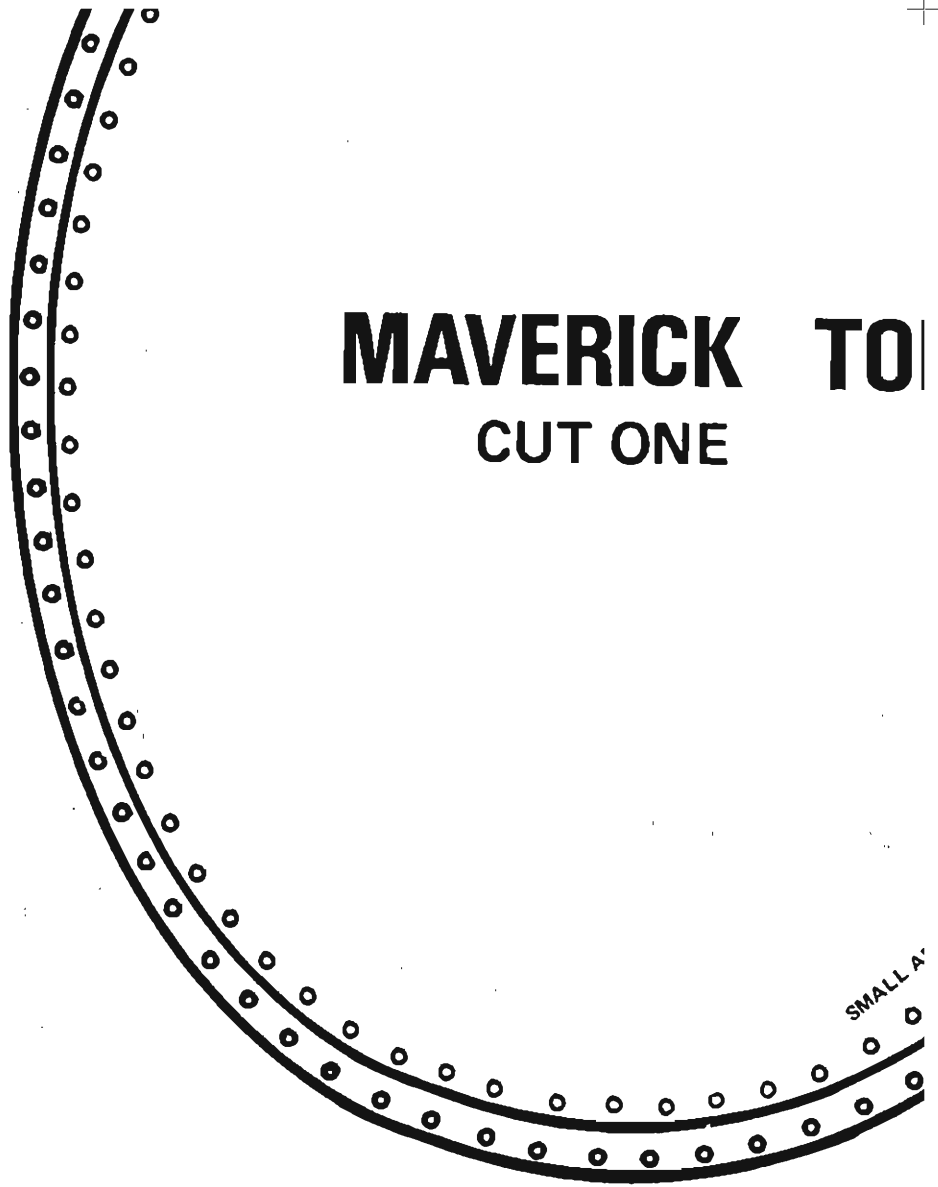

SMALL AT

P

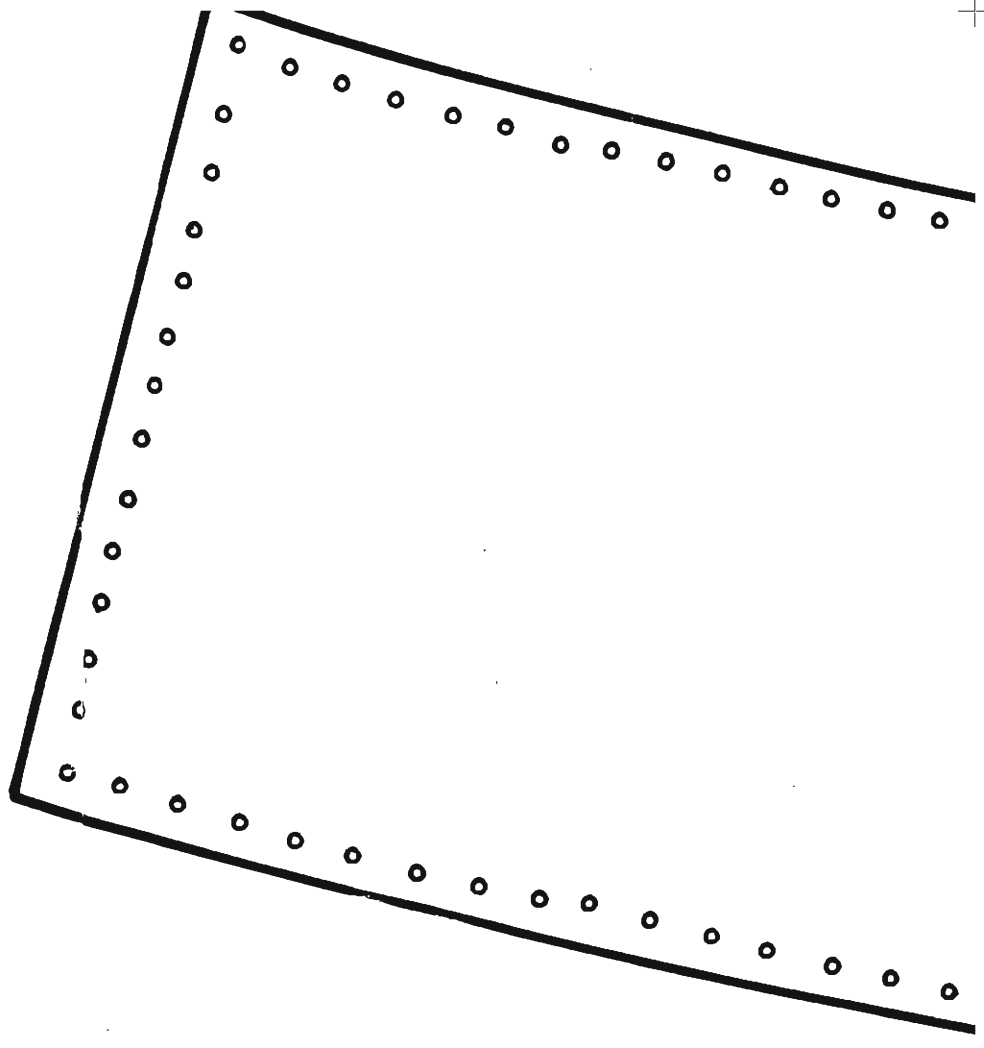
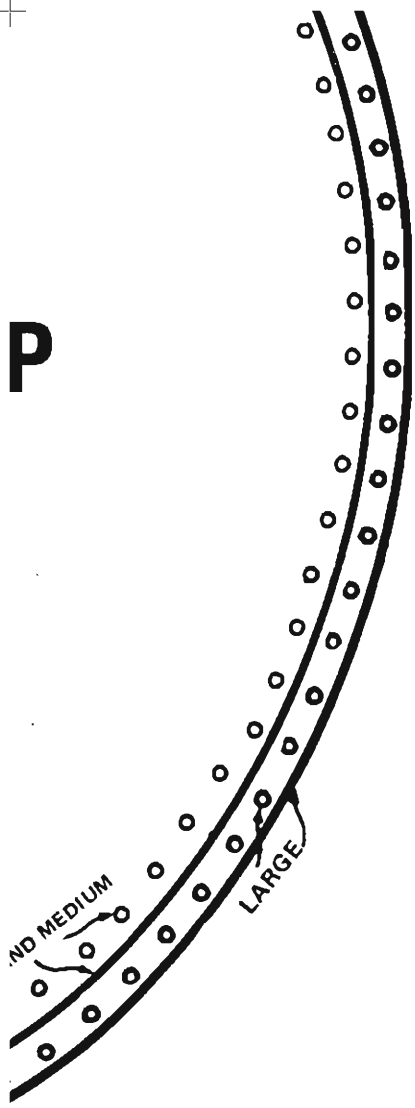

(No part of this or any other page may be reproduced without written permission)

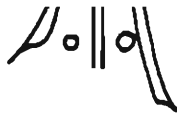

Step 1. From under side of leather insert ends of lace up through second pair of holes to top side

Step 2. Cross laces on top and insert through third pair of holes to under side. Cross lace on under side and insert up through fourth pair of holes to top.

Step 3. Continue as indicated. After insert through next pair of holes to under leather, tie ends.

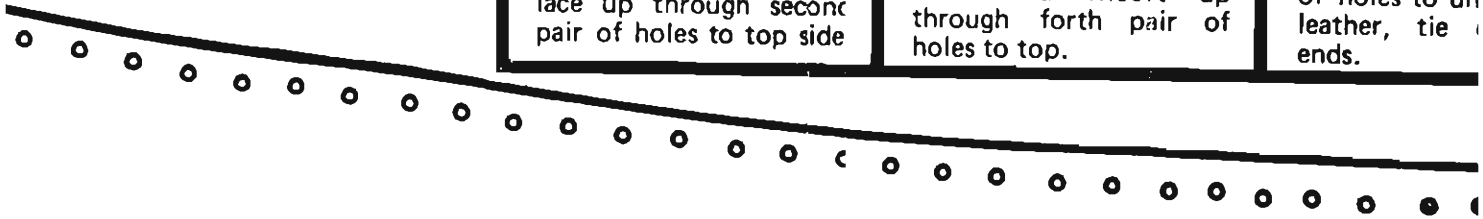

MAVERICK (

CUT ON

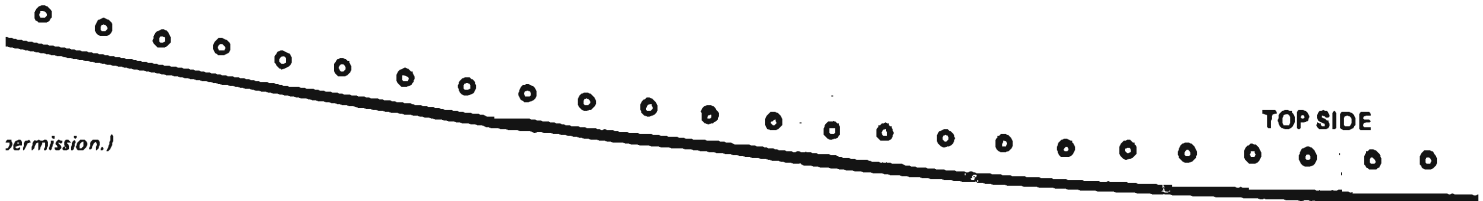

TOP SIDE

(permission.)

Continue lacing
in Step 2.
Starting lace
to last pair
under side of
or cement

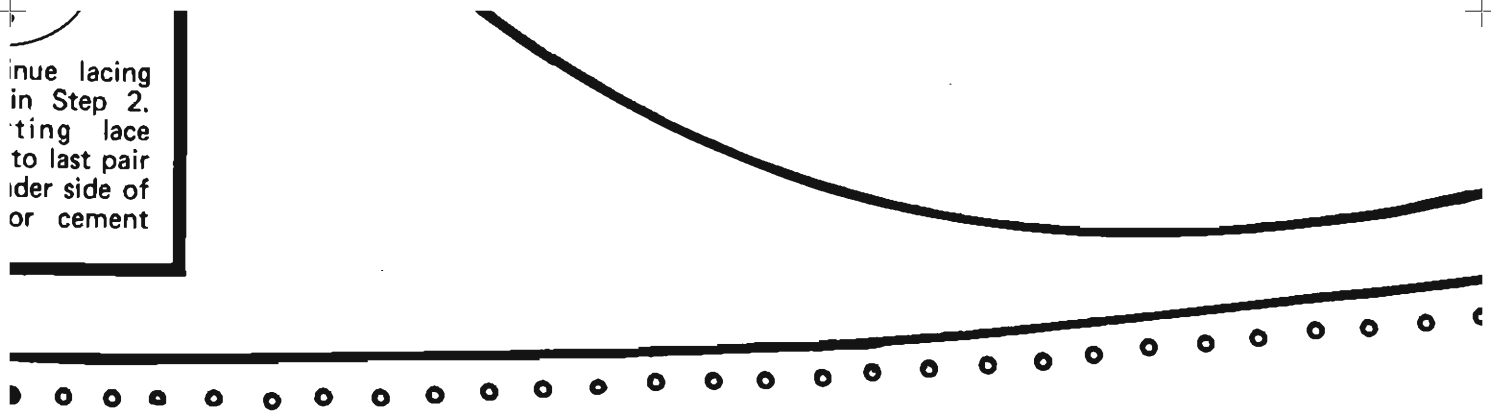

CROWN

E



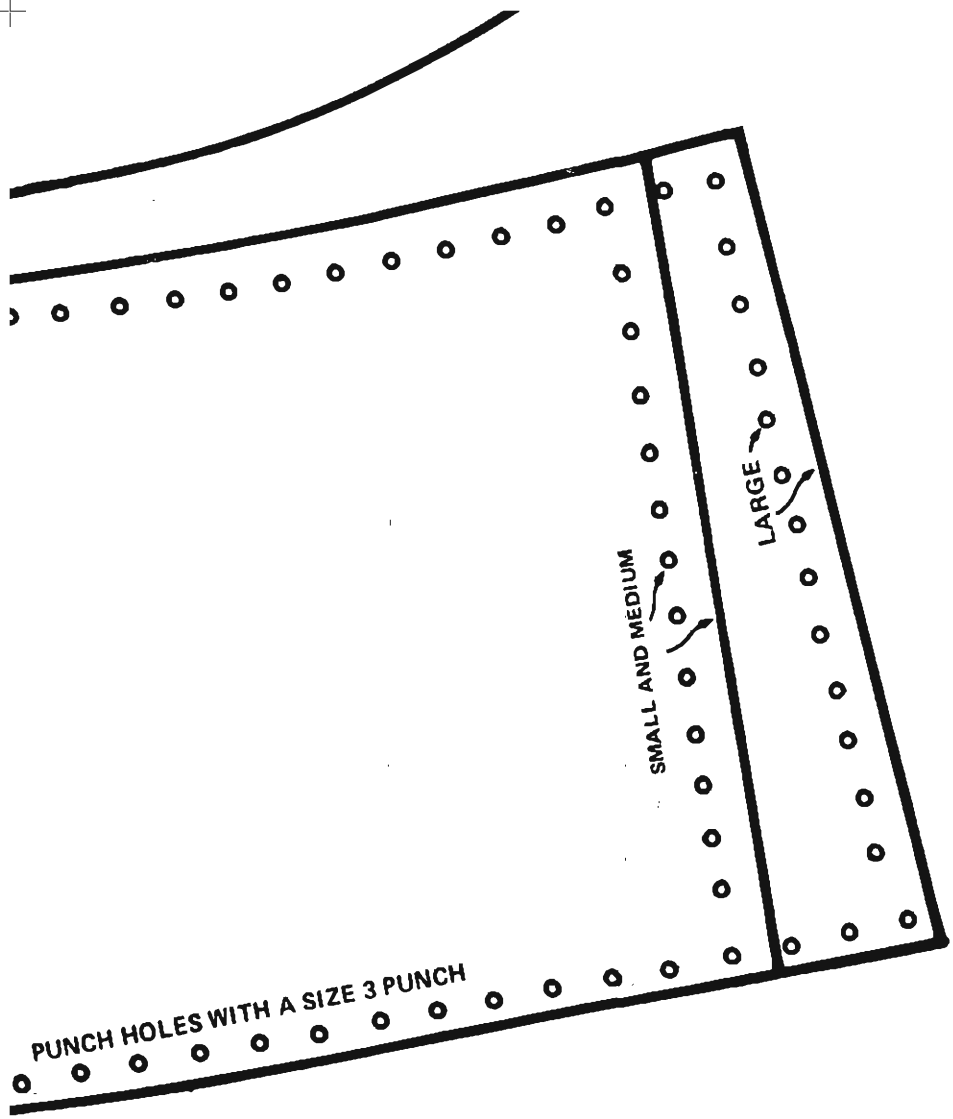

PUNCH HOLES WITH A SIZE 3 PUNCH

SMALL AND MEDIUM

LARGE

VISOR PATTERN

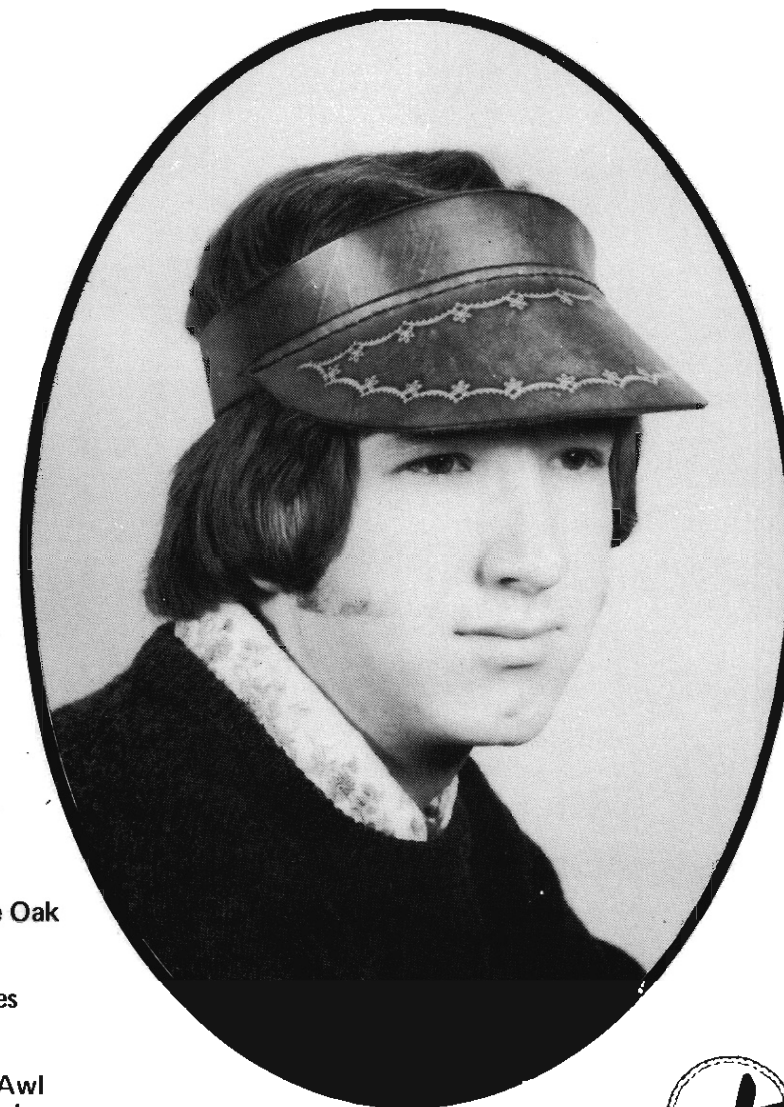

MATERIALS NEEDED:

- 7-8 oz. Nature-Tand or Live Oak Knife
- Two Size 00 Harness Needles
- 4 ft. Waxed Thread
- Size 2 Punch
- Size 00 Punch or Stitching Awl
- Craftool French Skiving Tool
- Craftool Bevel-edge Edge Beveler
- Size 2 (Optional)
- Craftool Circle Edge Slicker (Optional)
- 1 Medium Rapid Rivet
- Craftool Rivet Setter
- Craftool Leather Stamps (for the design of your choice)
- Omega Dye
- Omega Carnauba Cream or Finish Coat
- 1" Buckle



Distributed by
TANDY WAREHOUSE COMPANY
Fort Worth, Texas 76107

NATURE-TAND DYEING INSTRUCTIONS

The Nature-Tand dyeing technique allows you to apply dye to the surface of the leather to contrast with the stamped and natural impressions in the leather. With this technique the dye will not enter the stamped impressions. The dyes used are spirit solvent such as Omega Dye.

Step 1: Wrap a length of cloth around a sponge or wooden block several times. Apply dye to the cloth and blot on a paper towel until cloth has enough dye remaining to color only the surface of the leather. If too much dye remains it may run into the impressions. For shading an edge or small area, use a small piece of sponge without a cloth.

Step 2: With the cloth, apply dye to surface of leather, rubbing briskly so a burnished effect is achieved. Apply more dye to cloth as needed, blotting before applying to leather. Dye all edges.

For a distinctive edge, dye the edges and border area along them with dark brown or black.

For a more finished look, the back side of the Nature Tand leather may be dyed with Omega Dye and finished with Omega Carnauba Cream or Omega Finish Coat.

The basic colors recommended are: dark brown, medium brown, tan, light brown, Cordovan, or a combination of red (applied first) and dark brown.

Step 3: After dye has been applied, wait until leather dries before applying a finish. Omega Carnauba Cream or Finish Coat make excellent finishes for this type leather and dye.

RAPID RIVET SETTING INSTRUCTIONS

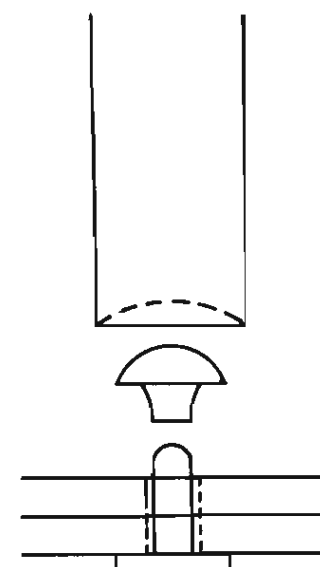

For best results use a rivet setter and rawhide mallet. Use rivet slightly longer than thickness of leathers. Punch hole in leather (use drive or rotary punch) slightly larger than rivet. Place rivet post through leathers and place on hard, smooth, dense surface. Place rivet cap on post. Place concave end of rivet setter on cap (be certain rivet is centered so edges of setter will not mark rivet cap) and tap sharply with rawhide mallet once or twice. Check to see that rivet is set tightly in leather and does not turn.

HANDSTITCHING INSTRUCTIONS

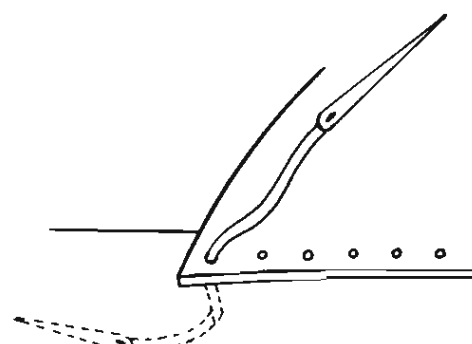

Step 1: Attach needle to each end of waxed thread and push one needle through first hole and pull to center to thread.

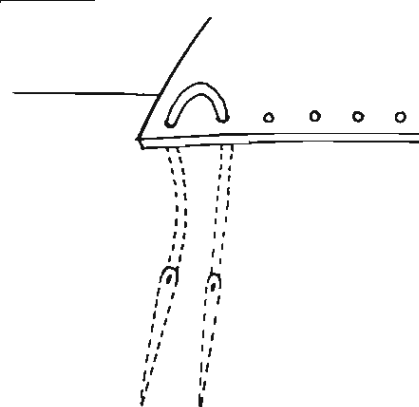

Step 2: Push needle from FRONT side through second hole.

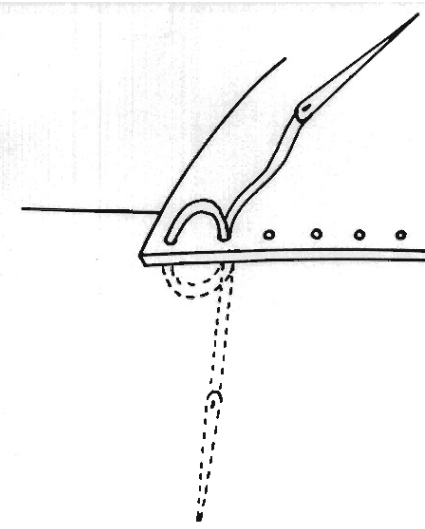

Step 3: Push needle from BACK side through same hole. Use care not to puncture thread with second needle.

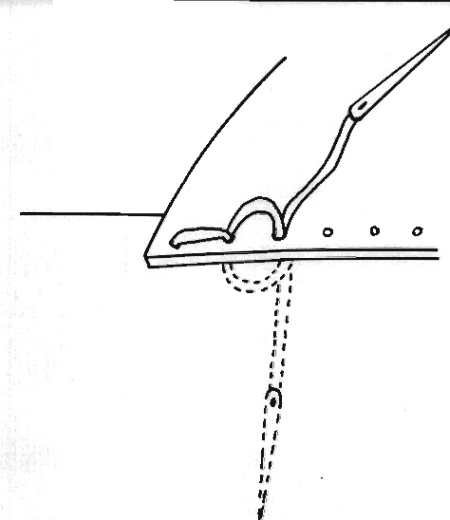

Step 4: Pull stitch tight. Push needle from FRONT side through third hole. Push needle from BACK side through same hole and pull stitch tight.

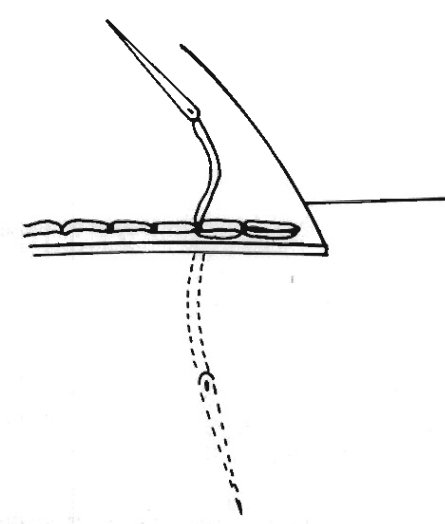

Step 5: To finish off, back stitch through last two holes and cut threads off flush with leathers.

ASSEMBLY INSTRUCTIONS FOR VISOR

Step 1: Use the cutting patterns to cut the leather parts and punch the holes. Skive the shaded area of the Visor Bill and edge the Visor Bill and Headband. Design the leather with designs of your choice, then dye and finish the parts following the Nature-Tand Dyeing Instructions.

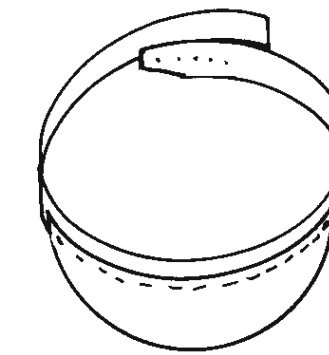

Step 2: Stitch the Visor Bill to the Headband following the Hand Stitching Instructions.

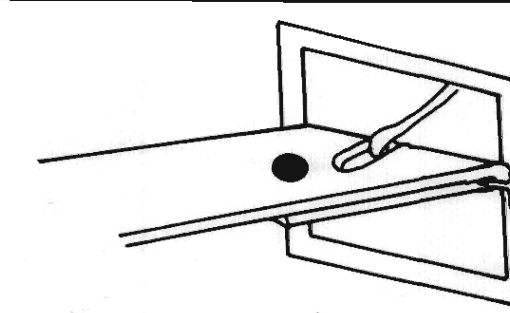

Step 3: Attach the 1" buckle to the headband with a medium Rapid Rivet following the Rapid Rivet Setting Instructions.

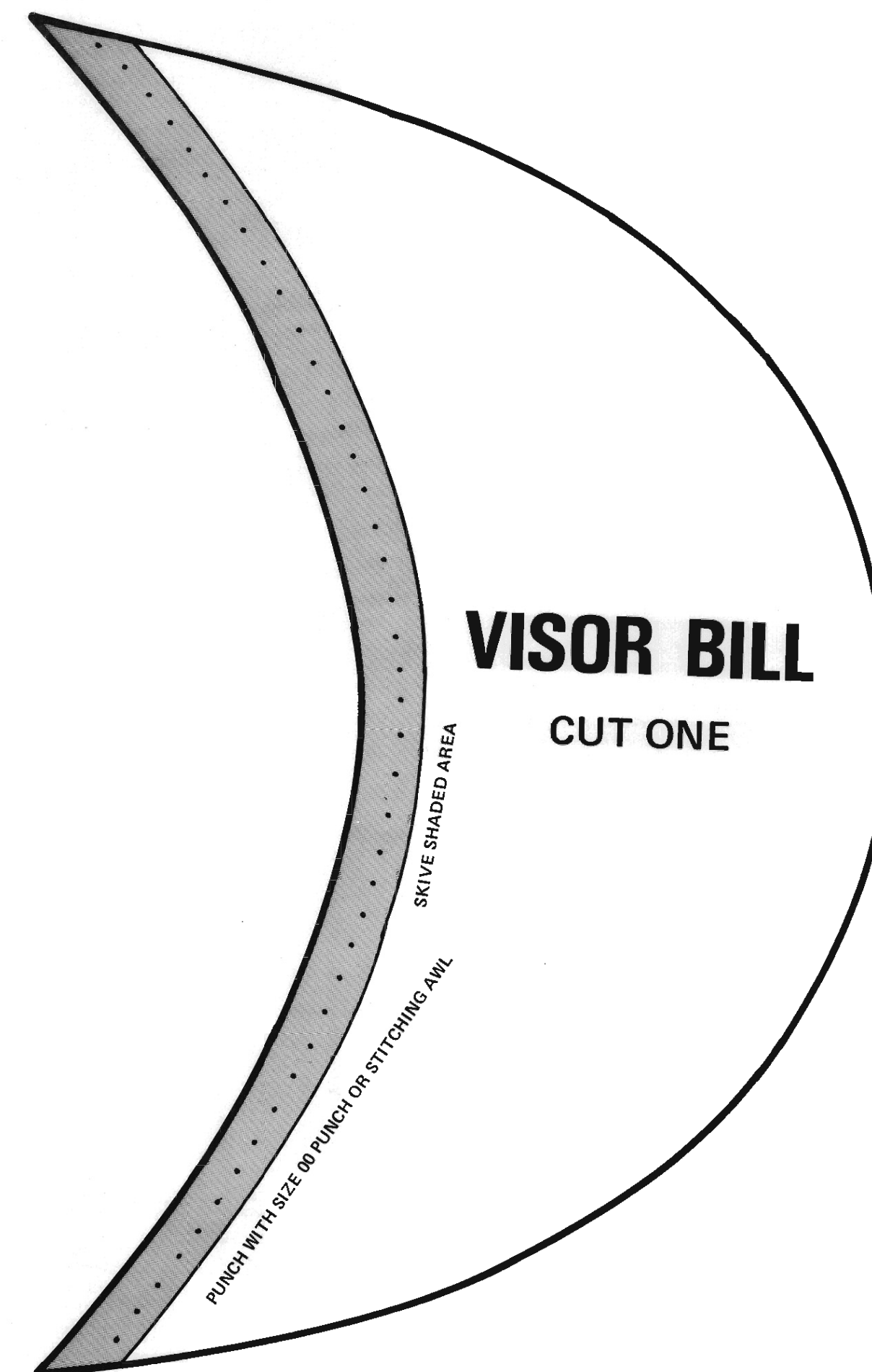

VISOR BILL
CUT ONE

SKIVE SHADED AREA
PUNCH WITH SIZE 00 PUNCH OR STITCHING AWL

(No part of this or any other page may be reproduced without written permission.)

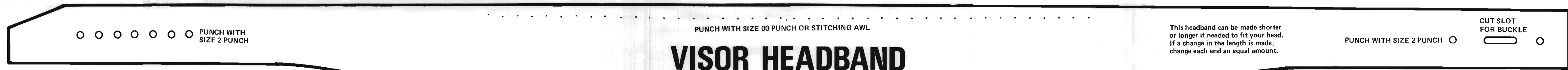

VISOR HEADBAND
CUT ONE

This headband can be made shorter or longer if needed to fit your head. If a change in the length is made, change each end an equal amount.

PUNCH WITH SIZE 2 PUNCH ○ CUT SLOT FOR BUCKLE ○

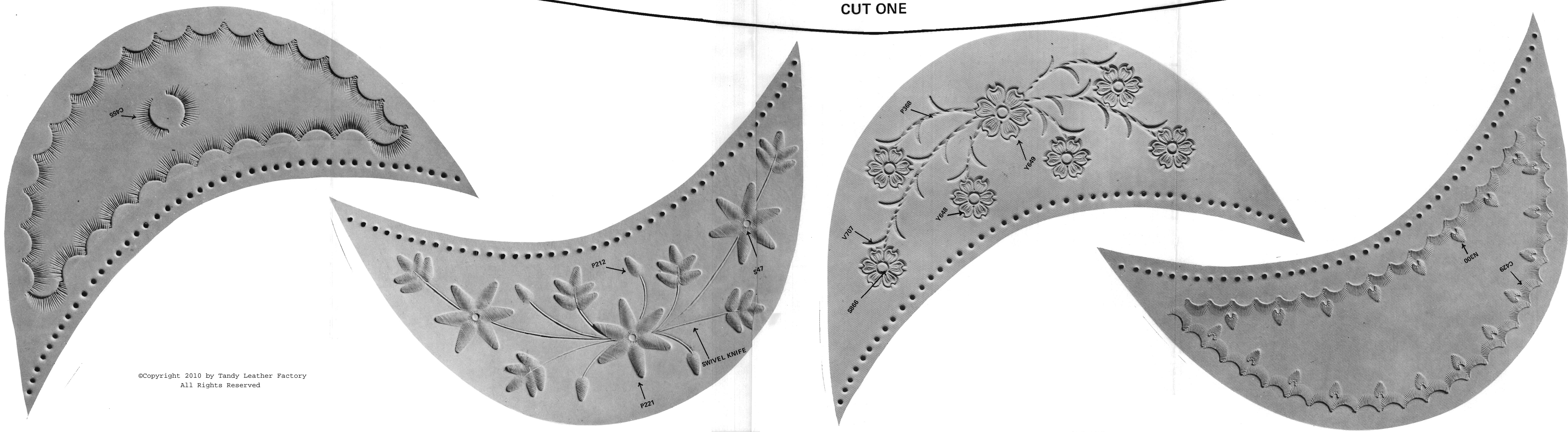

©Copyright 2010 by Tandy Leather Factory
All Rights Reserved

©Copyright 2010 by Tandy Leather Factory
All Rights Reserved

VISOR P/



ATTEN

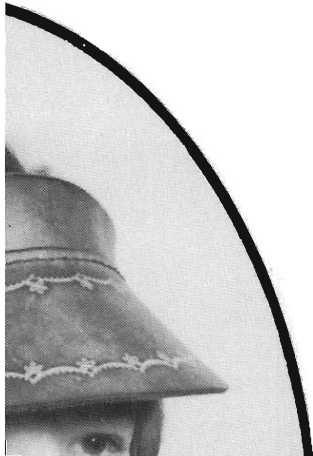

NATURE-TAND DYE

The Nature-Tand dyeing technique allows you to apply dye to the surface of the leather to contrast with the stamped and natural impressions in the leather. With this technique the dye will not enter the stamped impressions. The dyes used are spirit solvent such as Omega Dye.

Step 1: Wrap a length of cloth around a sponge or wooden block several times. Apply dye to the cloth and blot on a paper towel until cloth has enough dye remaining to color only the surface of the leather. If too much dye remains it may run into the impressions. For shading an edge or small area, use a small piece of sponge without a cloth.

Step 2: With the cloth, apply dye to surface of leather, rubbing briskly so a burnished effect is achieved. Apply more dye to cloth as needed, blotting before applying to leather. Dye all edges.

RAPID RIVET SETTING INSTRUCTIONS

ING INSTRUCTIONS

For a distinctive edge, dye the edges and border area along them with dark brown or black.

For a more finished look, the back side of the Nature Tand leather may be dyed with Omega Dye and finished with Omega Carnauba Cream or Omega Finish Coat.

The basic colors recommended are: dark brown, medium brown, tan, light brown, Cordovan, or a combination of red (applied first) and dark brown.

Step 3: After dye has been applied, wait until leather dries before applying a finish. Omega Carnauba Cream or Finish Coat make excellent finishes for this type leather and dye.

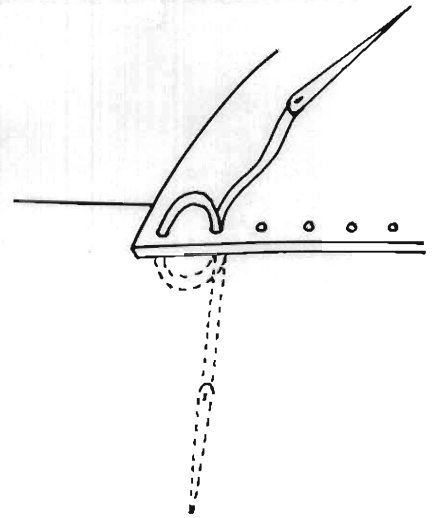

Step 3: Push needle from BACK side through hole. Use care not to puncture thread with needle.

HANDSTITCHING INSTRUCTIONS

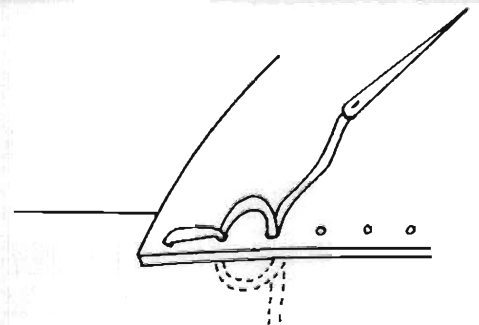

ASSEMBLY INSTRUCTIONS FOR VISOR

1 same
second

Step 1: Use the cutting patterns to cut the leather parts and punch the holes. Skive the shaded area of the Visor Bill and edge the Visor Bill and Headband. Design the leather with designs of your choice, then dye and finish the parts following the Nature-Tand Dyeing Instructions.

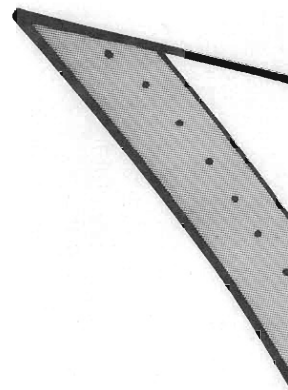

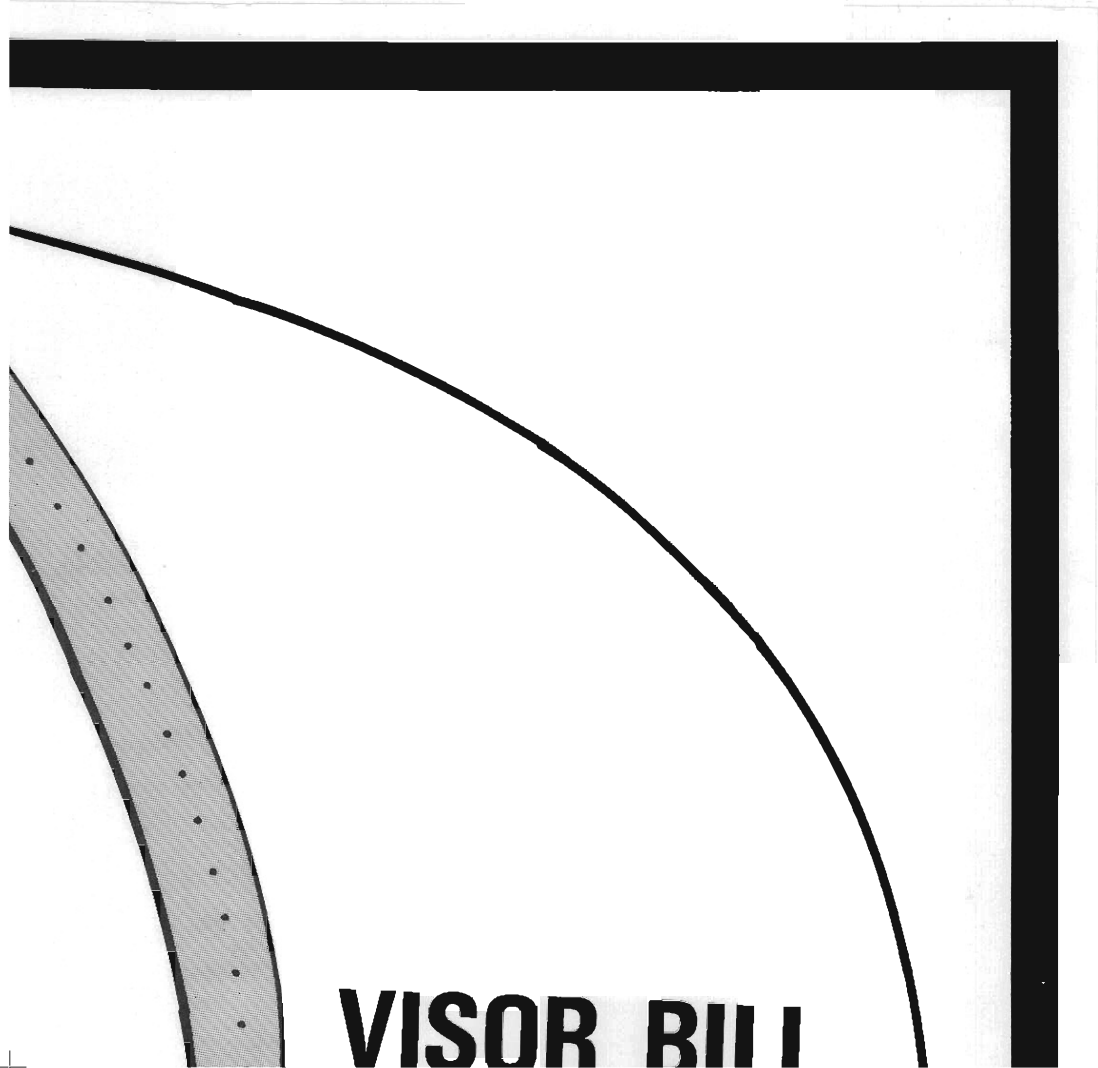

VISOR BIII



MATERIALS NEEDED:

- 7-8 oz. Nature-Tand or Live Oak
- Knife
- Mallet
- Two Size 00 Harness Needles
- 4 ft. Waxed Thread
- Size 2 Punch
- Size 00 Punch or Stitching Awl
- Craftool French Skiving Tool
- Craftool Bevel-eze Edge Beveler
- Size 2 (Optional)
- Craftool Circle Edge Slicker (Optional)
- 1 Medium Rapid Rivet
- Craftool Rivet Setter
- Craftool Leather Stamps (for the design of your choice)
- Omega Dye
- Omega Carnauba Cream or Finish Coat
- 1" Buckle

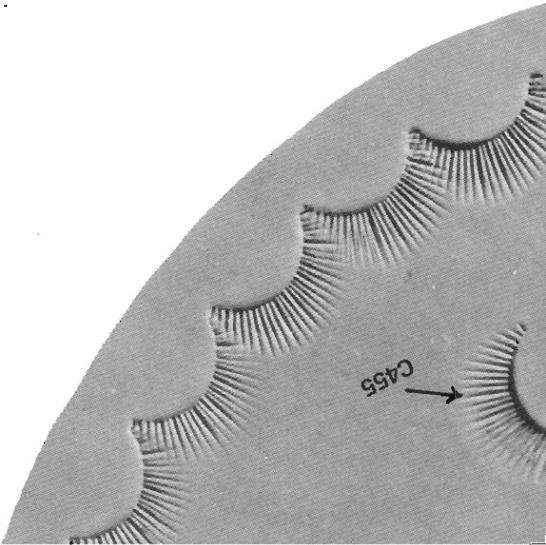



A TANDY CORPORATION COMPANY

Distributed by
TANDY WAREHOUSE COMPANY
Fort Worth, Texas 76107

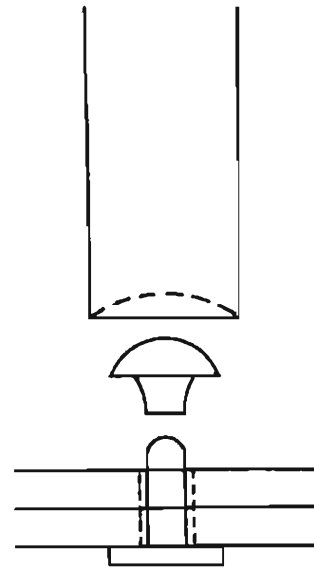

For best results use a rivet setter and rawhide mallet. Use rivet slightly longer than thickness of leathers. Punch hole in leather (use drive or rotary punch) slightly larger than rivet. Place rivet post through leathers and place on hard, smooth, dense surface. Place rivet cap on post. Place concave end of rivet setter on cap (be certain rivet is centered so edges of setter will not mark rivet cap) and tap sharply with rawhide mallet once or twice. Check to see that rivet is set tightly in leather and does not turn.

○ ○ ○ ○ ○ ○ ○ PUNCH WITH
SIZE 2 PUNCH

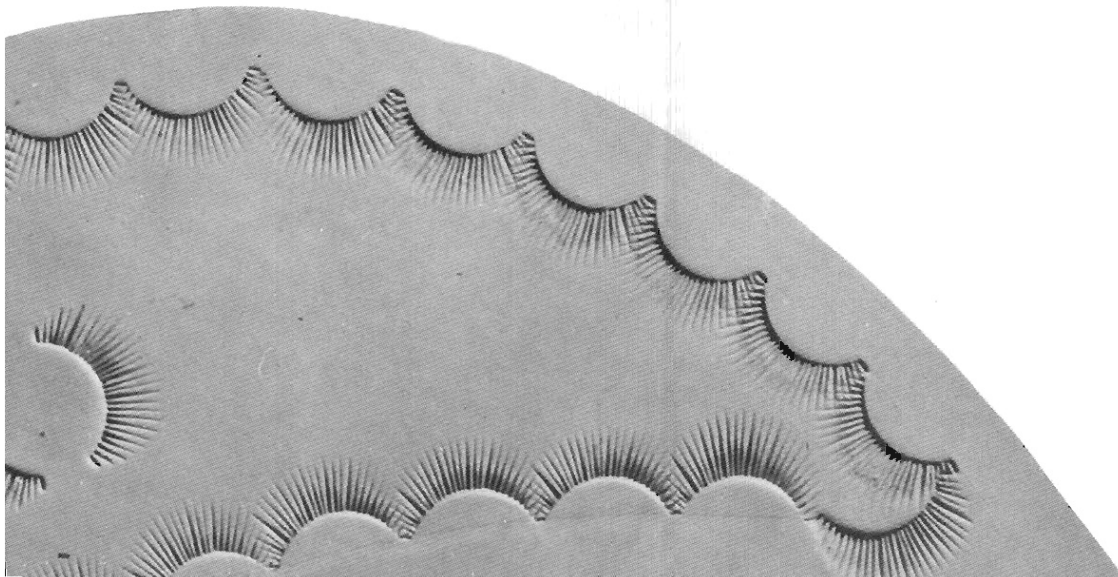

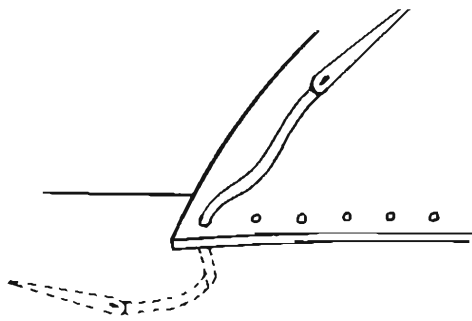

Step 1: Attach needle to each end of waxed thread and push one needle through first hole and pull to center to thread.

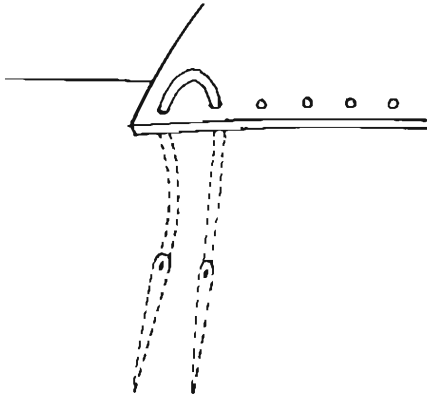

Step 2: Push needle from FRONT side through second hold.

Step 4: Pull stitch tight. Push needle from FRON through third hole. Push needle from BACK through same hole and pull stitch tight.

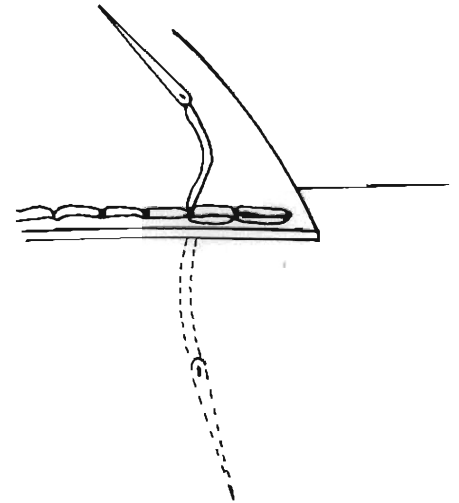

Step 5: To finish off, back stitch through last two and cut threads off flush with leathers.

(No part of this or any other page may be reproduced without written permission.)

PUNCH WITH SIZE 00 PUNCH OR STITCHING

VISOR HEADB

CUT ONE

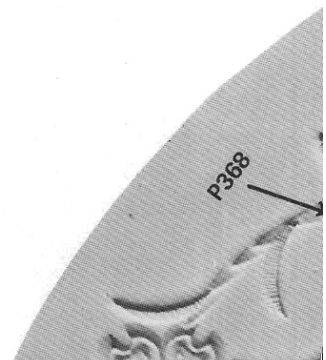
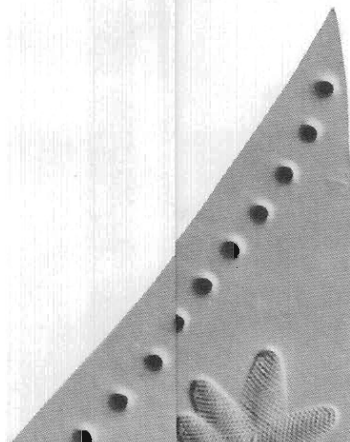

T side
side

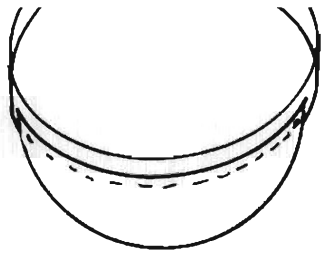

Step 2: Stitch the Visor Bill to the Headband following the Hand Stitching Instructions.

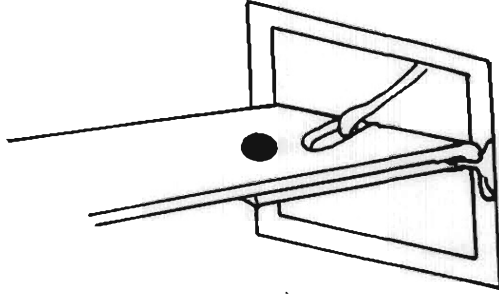

Step 3: Attach the 1" buckle to the headband with a medium Rapid Rivet following the Rapid Rivet Setting Instructions.

holes

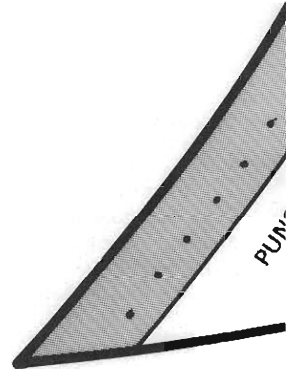

AWL

AND

This headband can be made shorter or longer if needed to fit your head. If a change in the length is made, change each end an equal amount.



CUT ONE

SKIVE SHADED AREA

PUNCH WITH SIZE 00 PUNCH OR STITCHING AWL

PUNCH WITH SIZE 2 PUNCH ○

CUT SLOT FOR BUCKLE

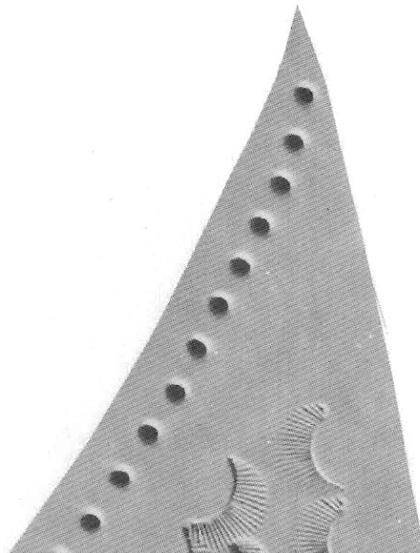
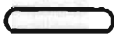

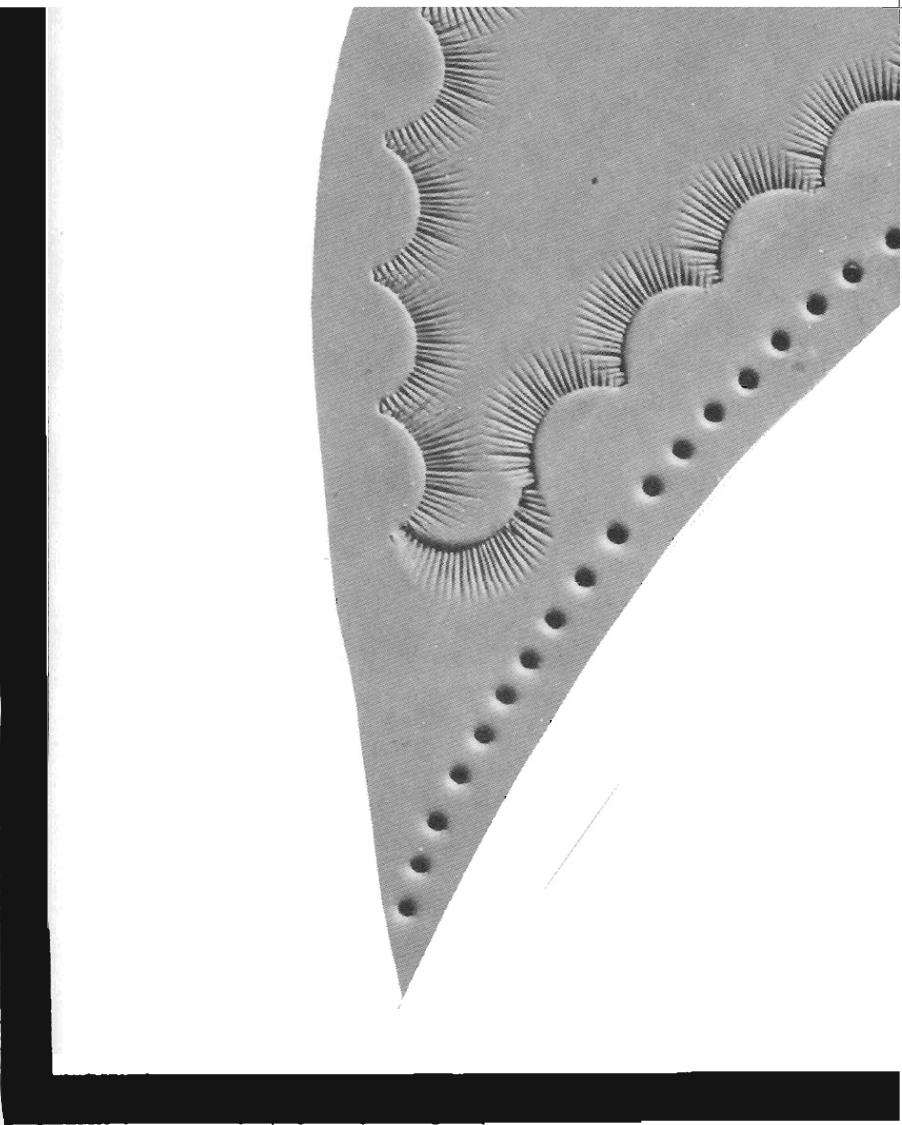

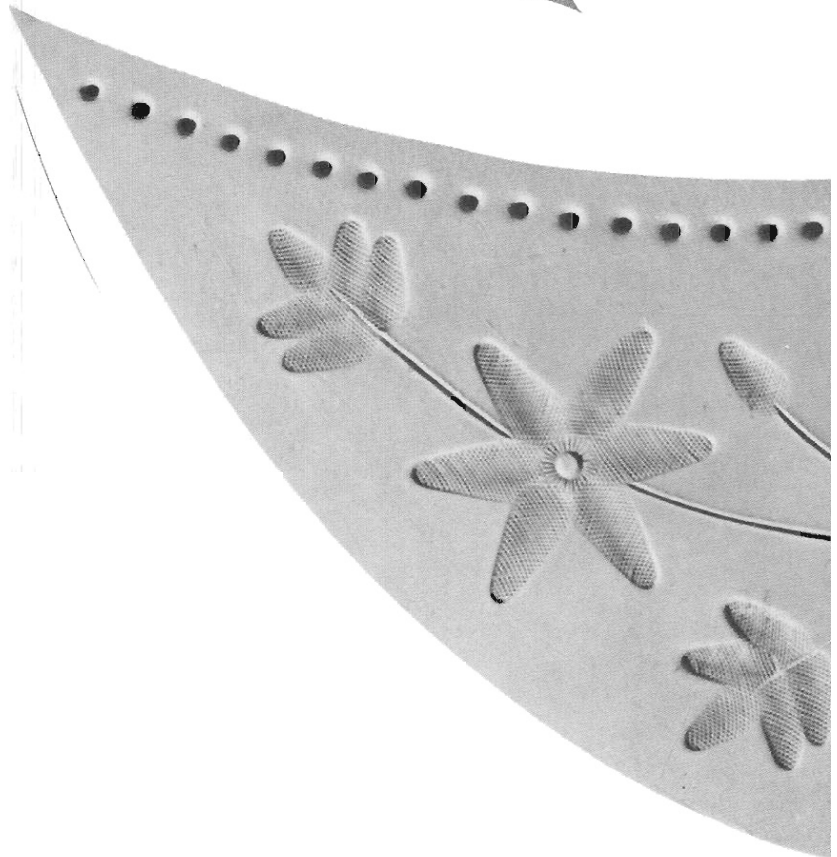
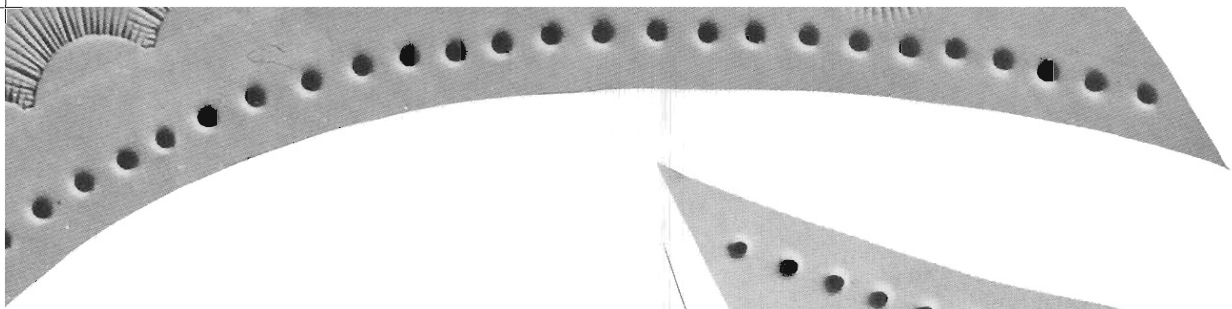

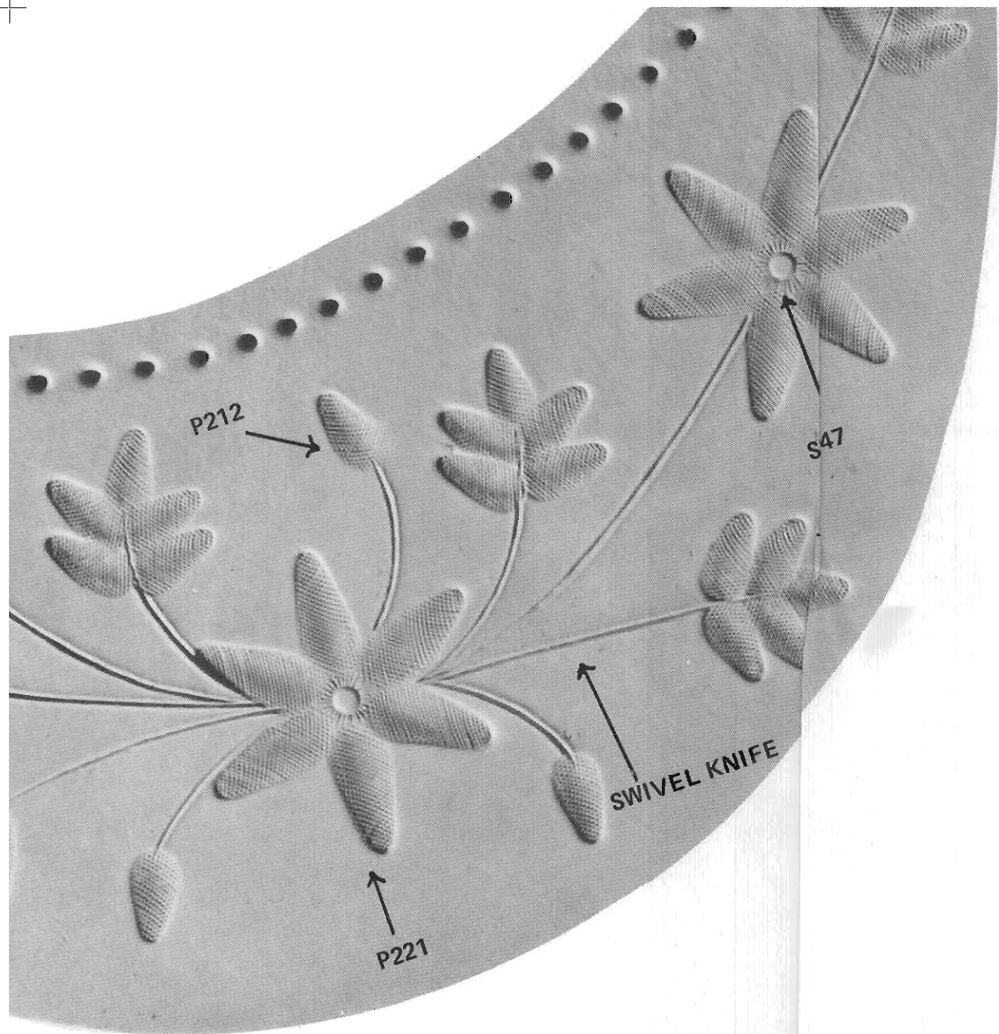

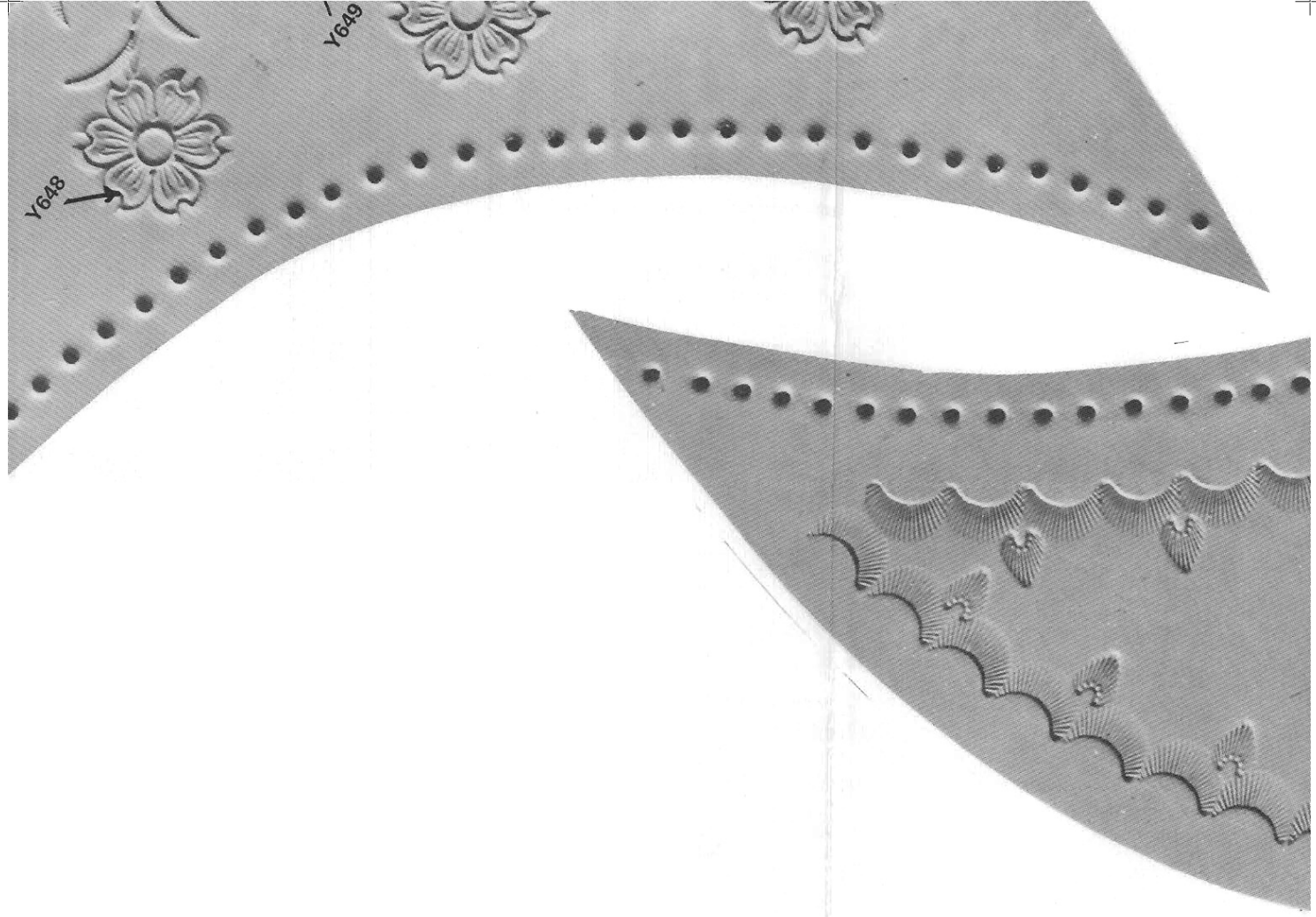

Y649

Y648

