



# From Tony Laier's Bench:

## Make A Putting Golf Ball & Tee Holder With Belt Flap Or Clip

### CUTTING PATTERN

1/8" RIVET HOLES IN SIDE FLAPS

1/8" RIVET HOLES IN SIDE FLAPS

FRONT OF HOLDER  
STAMP INITIAL OR 3D STAMP  
NOTE: Design on photo sample was made using D436, A888 and Initial from "Alphabets For The Leathercrafter" Book #61936-00



### YOU WILL NEED:

- 4 to 5 oz. Veg-Tan Tooling Leather
- 4 Medium Rapid Rivets
- 1 Short Baby Dot Snap Craft or Head Knife
- 1/8" Hole Punch
- Rivet & Snap Setters With Anvil
- Optional: Small Steel Belt Clip & 7/32" Hole Punch

NOTE: Tool, dye, apply finish and let dry completely before assembly.

### ASSEMBLY:

STEP 1: Cut holder out of leather following cutting pattern.

STEP 2: Punch rivet and snap holes where shown. Note: Punch holes & slot for optional steel belt clip.

STEP 3: Fold side flaps around back flaps and set 4 rivets.

STEP 4: Set baby dot snap in tongue and belt flap, as shown (A).

STEP 5: Optional - Insert small steel belt clip as shown (B).

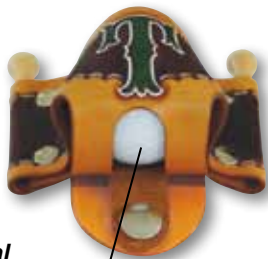

HOLE ON BOTTOM OF HOLDER FOR PUSHING BALL OUT EASILY

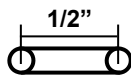
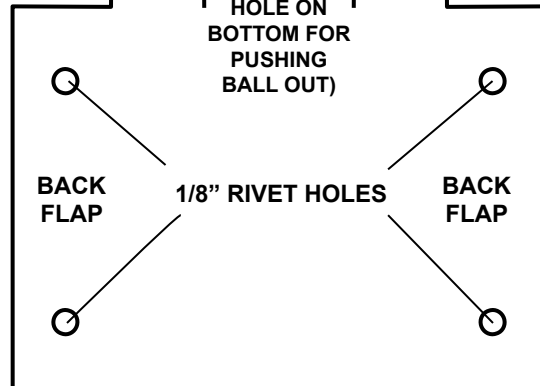
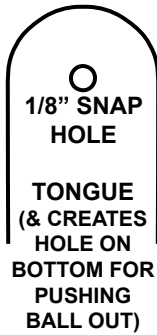

CUT IN SLOT WITH A 1/8" HOLE PUNCH AND KNIFE

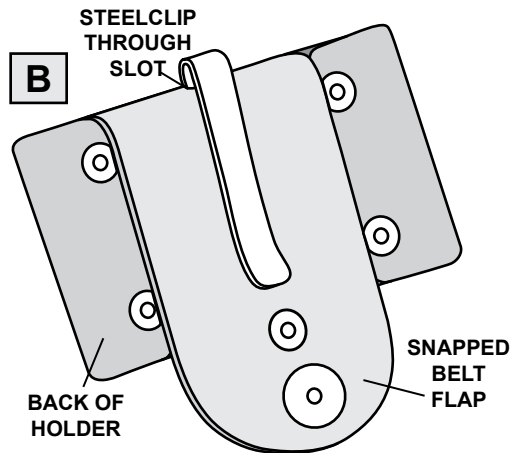
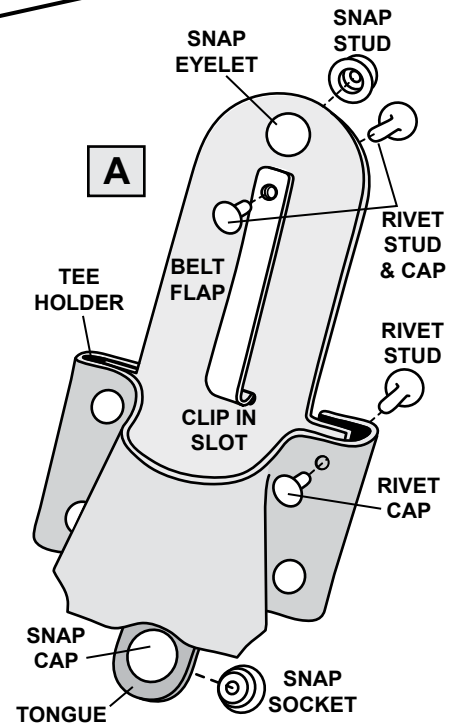
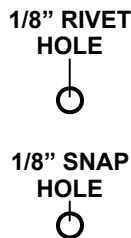

NOTE: REMOVE CLIP WHEN SNAPPED BELT FLAP IS USED.





## Digital Downloads

This PDF package has been put together to give you options when it comes to printing. Some PDF file downloads may contain some documents larger than an 8-1/2" x 11" image. Pages and patterns that are larger than 8½x11 have been provided in two formats:

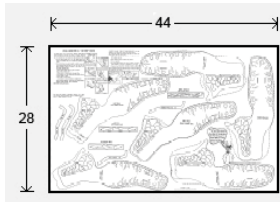

**Full Size:** If you would like to have a full size print out, take the full size pages to your local print shop and they can print it for you.

**Tiled:** The tiled pages give you the option of printing the larger patterns at home. You print the tiled pages and then assemble them to make the larger patterns.

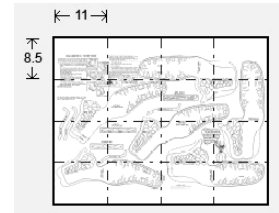

**Pattern PDF files** are typically laid out as follows: Cover (if applicable), instructions sheets (if applicable), pattern 1 – full sized, pattern 1 – tiled, pattern 2 – full sized, pattern 2 – tiled, pattern 3 – full sized, pattern 3 – tiled. ...Etc.

**Doodle Page PDF files** are typically laid out as follows: Front – full sized, front – tiled, back – full sized, back – tiled (Some Doodle Pages do not have backs).

**eBook PDF files** contain 1 (one) full eBook. All pages in the PDF are full sized. This means that you may have to take the PDF to a print shop for certain oversized books if your home printer cannot print the larger pages.

**Craftaid PDF files** contain 1 (one) full Craftaid pattern or Craftaid pattern pack that has been converted into a tracing pattern. All pages in the PDF are full sized. This means that you may have to take the PDF to a print shop for certain oversized Craftaid patterns if your home printer cannot print the larger pages. **NOTE: These digitized patterns do not include any of the physical plastic templates (Craftaids) that may be mentioned, nor does the purchase of this PDF file imply a promise to receive any physical plastic templates (Craftaids).**

**NOTE: Digital kit patterns do not include any kit parts that they may reference.**

Please note: When printing on a home printer, use the settings seen on the image to the right in the Page Handling area of the Adobe Reader print dialogue box. If your printer is cutting edges off, set "Page Scaling" to "Shrink to Printable Area". This will, however, decrease the size of the pattern a very small amount.

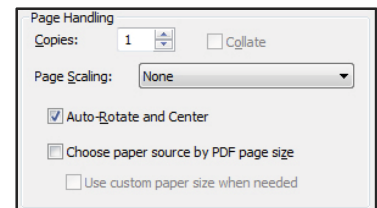

**NOTE: Some patterns may reference tools, and other items no longer available.**

**NOTE: You may take this PDF file to your local print shop to have the full-size pages printed for your own personal use.**

This premium has been published by Tandy Leather Factory, 1900 South East Loop 820, Ft. Worth, TX 76140. Copyright © 2011 by Tandy Leather Factory, all rights reserved. The contents of this publication may not be reproduced either in whole or in part without the consent of the copyright owner.

Please respect the copyright by not forwarding or distributing this document.