



ideas for LEATHER BELTS

you can make





eBook Digital Download

This PDF file contains 1 (one) full eBook. All pages in the PDF are full sized. This means that you may have to take the PDF to a print shop for certain books if your home printer cannot print the larger pages.

You may take this PDF file to your local print shop to have the full-size pages printed for your own personal use.

© Copyright 2010 by Tandy Leather Factory

All Rights Reserved

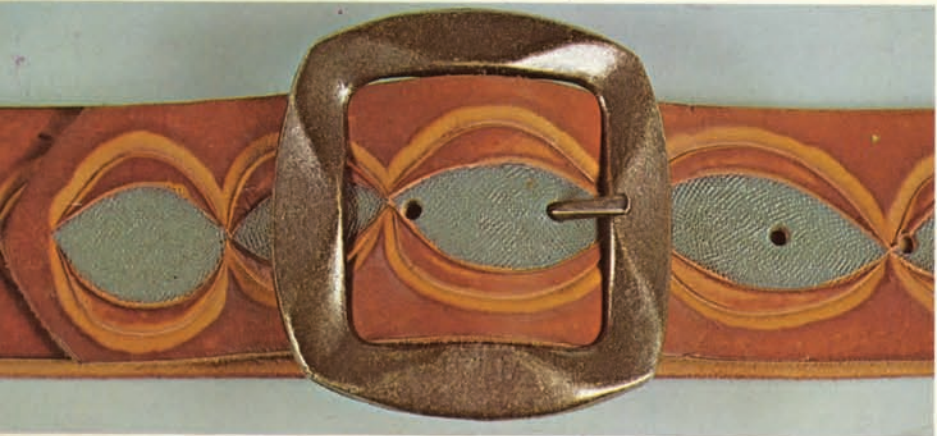

ideas for leather belts you can make

introduction

AS ANCIENT AS THE ROMAN EMPIRE ... as current as the Age of Aquarius — the quintessence of timelessness! No expression of superlatives can aptly witness to the patrician elegance of leather belt art. An aesthetic form that speaks for itself more than any other, the carved leather belt combines the rustic caprice of nature's most versatile and rugged material with the classic stamp of man's most disciplined efforts to achieve a truly personal art — one that is at once both naturally sublime yet eminently practical! The masters of the art of carving have long cherished and guarded their secrets, passing them on only to truly serious craftsmen willing to serve long and grueling apprenticeships.

BUT YOUR INTEREST HAS BEEN AWAKENED ... A LATENT DESIRE FOR EXPRESSION IN THIS TECHNOLOGICAL AGE HAS SPRUNG FORTH ... long dormant skills and talents restlessly demand fruition ... and so with the wisdom of ages man has turned once again to an art that is pragmatic and natural ... and predictably, that art is leathercarving!

Anyone can now participate — simplified instructions by the finest leather belt artists make it all possible. A whole spectrum of belt designs right here in one book — from the classical figure carving of Al Stohlman to the renaissance of floral and geometric designs by new artists like Dick Bloomquist. Accomplished artists like Jerry Jennings and Gene Noland include their latest offerings, and as an extra bonus Jerry has designed some belts to be made in blues and reds on Live Oak leather, the most convenient and beautiful ready-to-tool leather available anywhere. Tips on dyeing, stamping, tooling, detail work ... all written especially for you ... the beginner or seasoned craftsman ... to start you in on a new era in the making of leather belts.

table of contents

introduction.....	3
general instructions.....	4
al stohlman belts.....	9
jerry jennings belts.....	13
jerry jennings nature design belts.....	15
gene noland belts.....	31
dick bloomquist belts.....	33
mystery belts.....	34

leather for making belts

The best leathers for making casual and tooled belts are Live Oak, Nature-Tand and Latigo, although Latigo is not recommended for tooling.

When making 1 1/2", 1 3/4", 2" or wider belts, use 8-9 oz. or 9-10 oz. leather. When making 3/4", 1" or 1 1/4" belts, use 7-8 oz. leather

You may prefer to use Belt Blanks already cut to the proper width, and sized in small, medium and large lengths. Belt Blanks already have the buckle end skived, the slot punched and the snaps set. You only need to size the belt and punch the belt tip holes.



cutting belts

THE ILLUSTRATION SHOWS ONE SIDE (1/2 HIDE) OF COWHIDE

THE BACK (separated by broken line shown) is the best part of the hide for top quality belts ... legs, bellies and flanks are too soft and stretchy ... shoulders and necks too spongy and wrinkled.

The leather closest to the backbone of the animal is firmer and tighter grained. The closer towards the belly and neck ... the softer and looser the fibers become ... the "stretchier" the leather.

For best results ... ALWAYS cut belts LENGTHWISE of the hide!

For the craftsman making several belts, it is most economical to buy leather backs ... rather than sides ... as he will have no legs or bellies to waste. Unless, of course, he has other projects to use them on.

The belts can be cut with a straight edge and knife, or a Strip Ease, Draw Gauge, or Leather Stripper can be used to strip them.

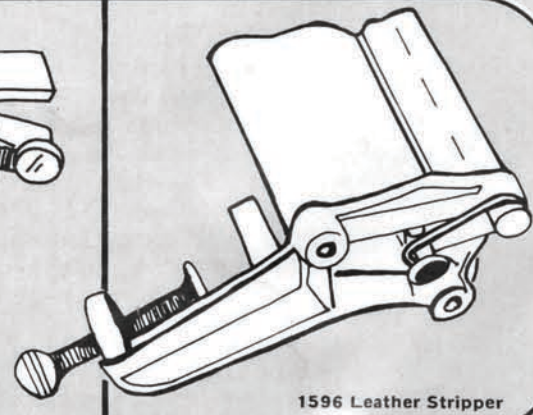
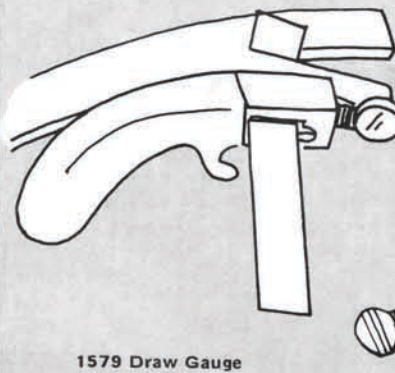
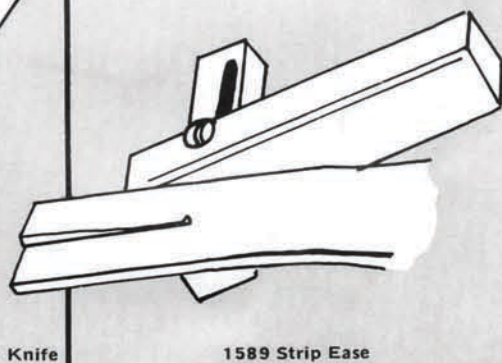
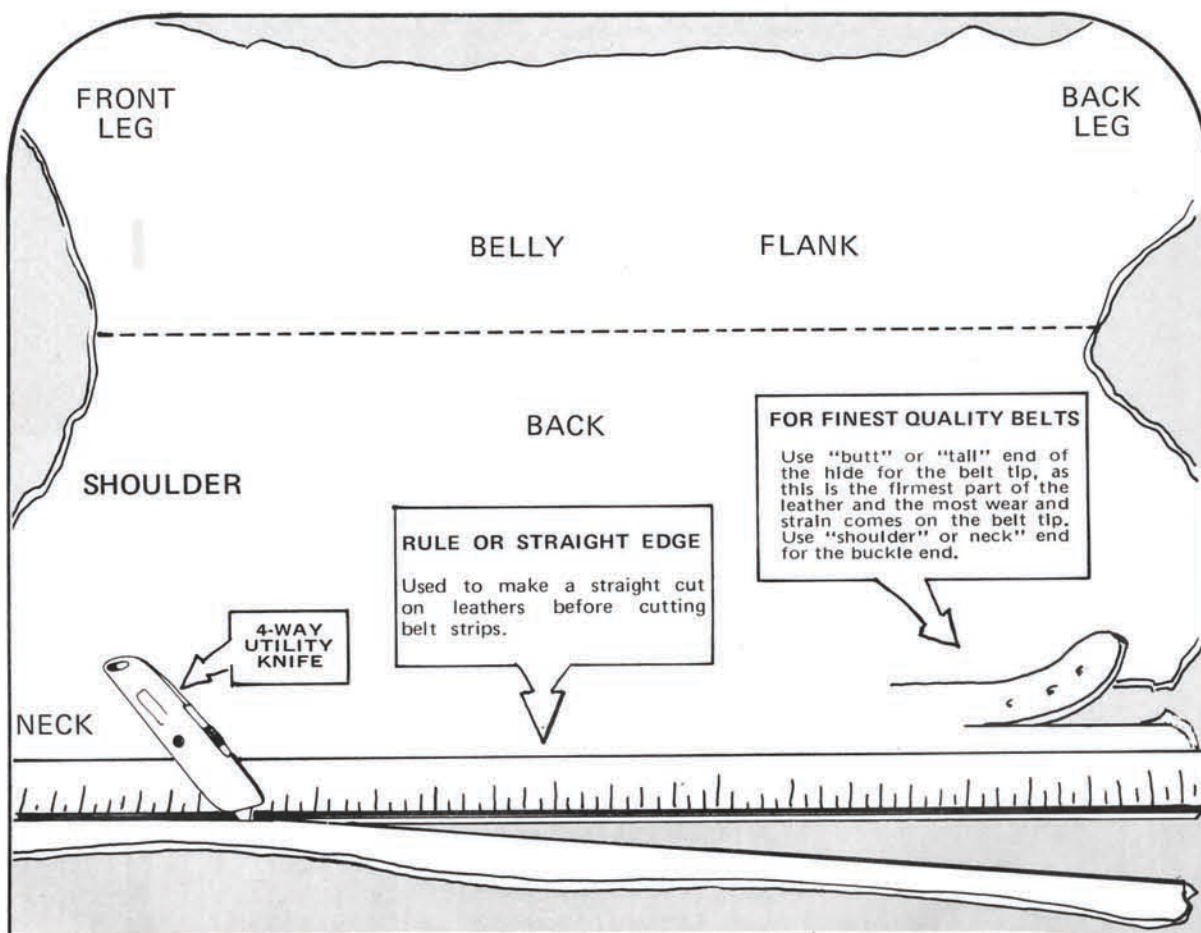

sizing belts

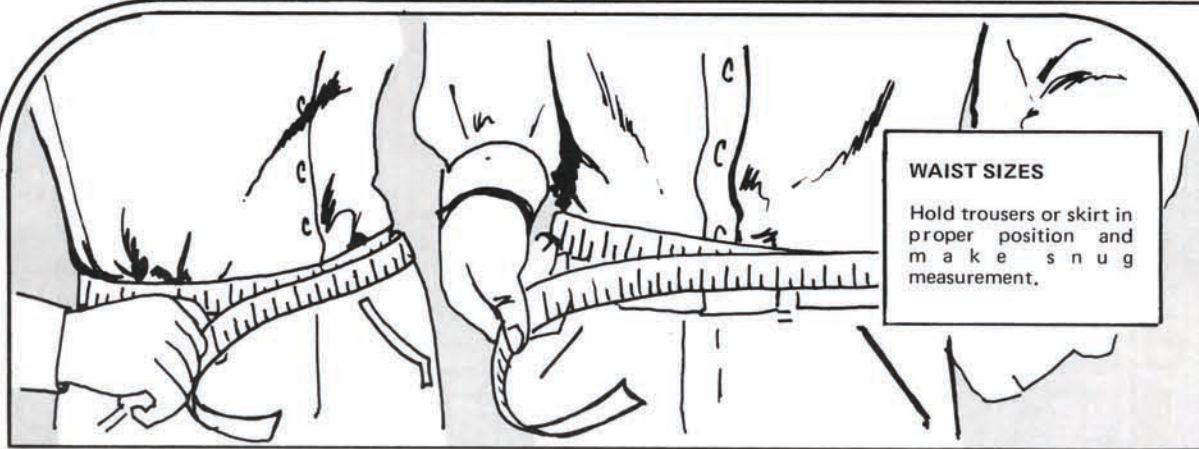

WAIST SIZES
Hold trousers or skirt in proper position and make snug measurement.

Step 1. Determine the waist size: To obtain the proper waist size, remove old belt and pull tape snugly around **OUTSIDE** of belt loops of garment. **DO NOT PULL THE TAPE TIGHTLY.**

NOTE: Quite often, a waist size can best be taken from an old belt that wearer is comfortable with. Follow the instructions at left for measuring.

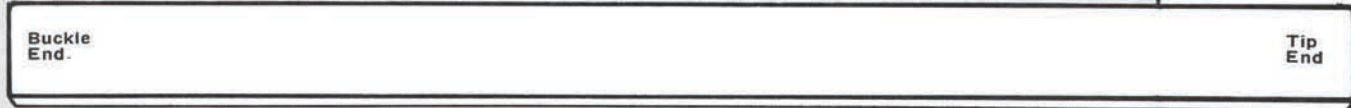
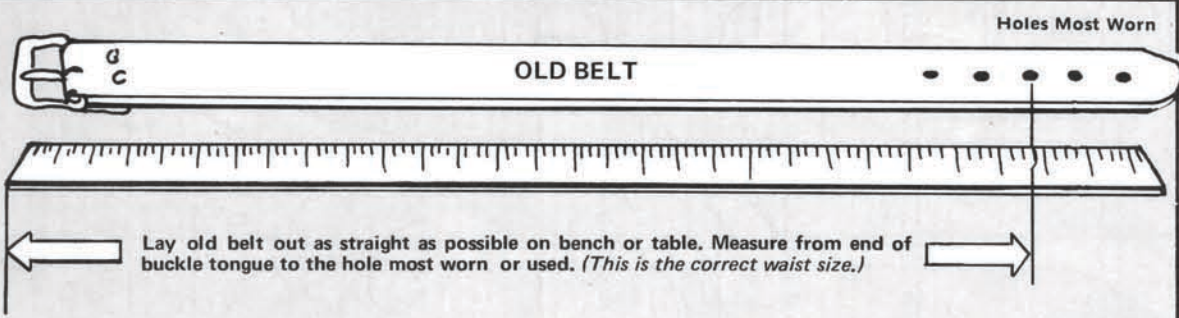

Step 2. Cut a strip of leather the desired width, and 10" longer than the waist size. Select firmest end for belt tip.

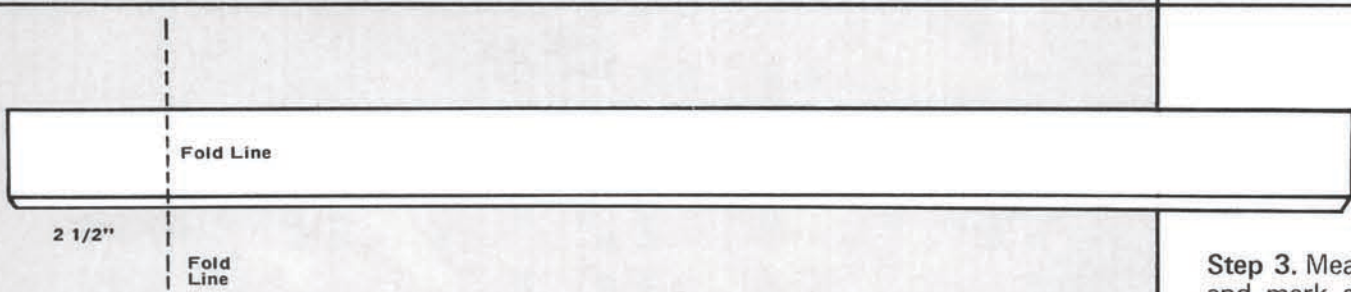

Step 3. Measure back 2 1/2" from buckle end and mark a "fold line" on the leather. This measurement is for buckles with **ONE** keeper (belt loop).

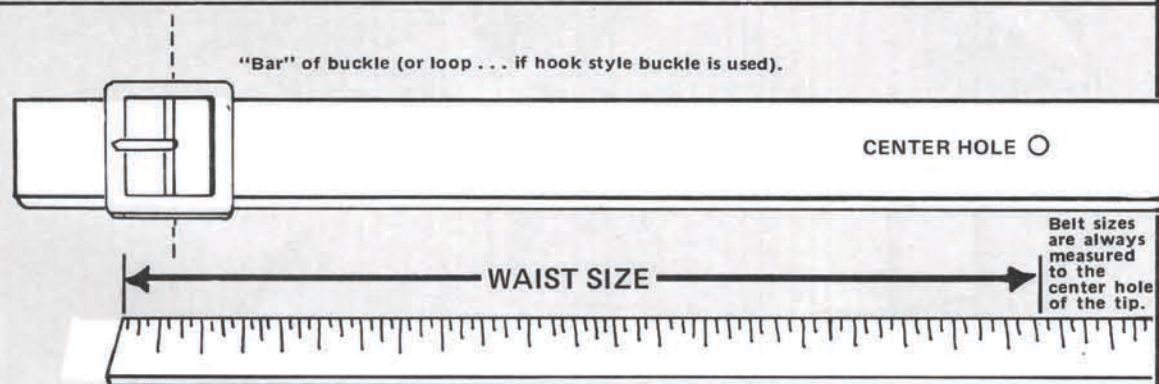

Step 4. Place the buckle with bar at fold line as shown at left. Begin from end of buckle tongue (or hook — if hook style buckle is used). Measure the waist size and mark the belt tip. This mark will be the center hole in the tip.

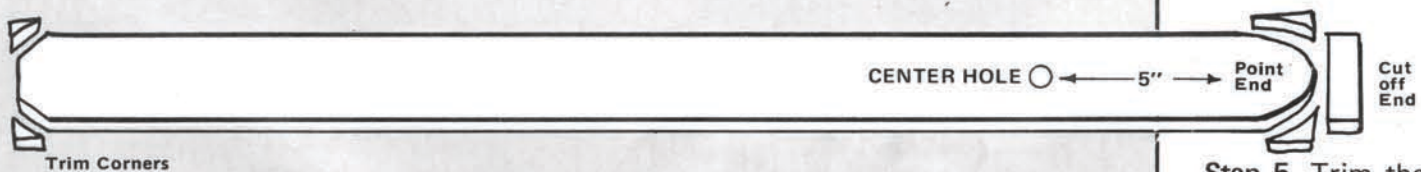

Step 5. Trim the corners of the buckle end, and trim the tip end to the desired shape. Allow 5" beyond the center hole.

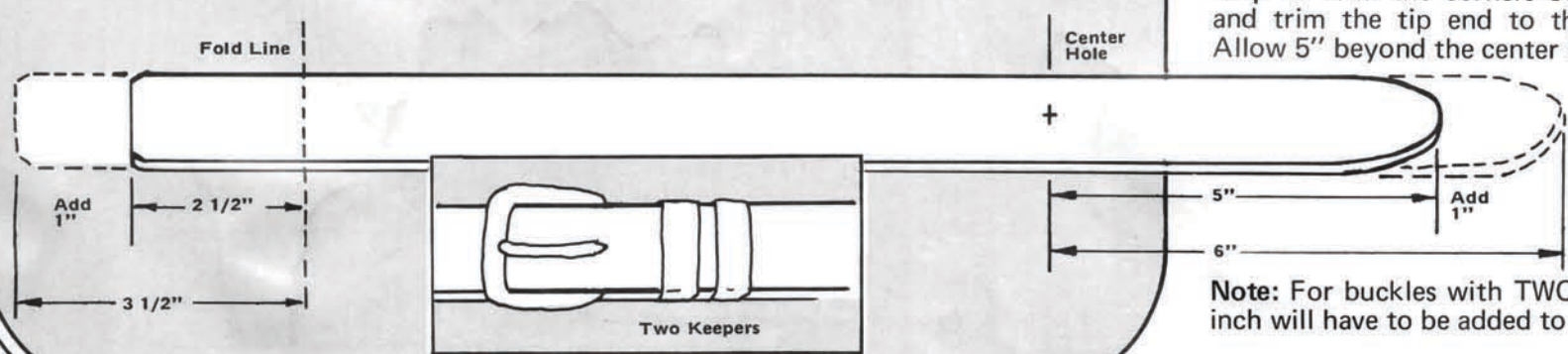

Note: For buckles with **TWO KEEPERS**, one inch will have to be added to each end.

tipping belts

Step 1. Make a tracing pattern of the size and style tip you wish to use for your belt. Use the tracing pattern to mark your belt tip, then cut belt tip to size and pattern shape with knife.

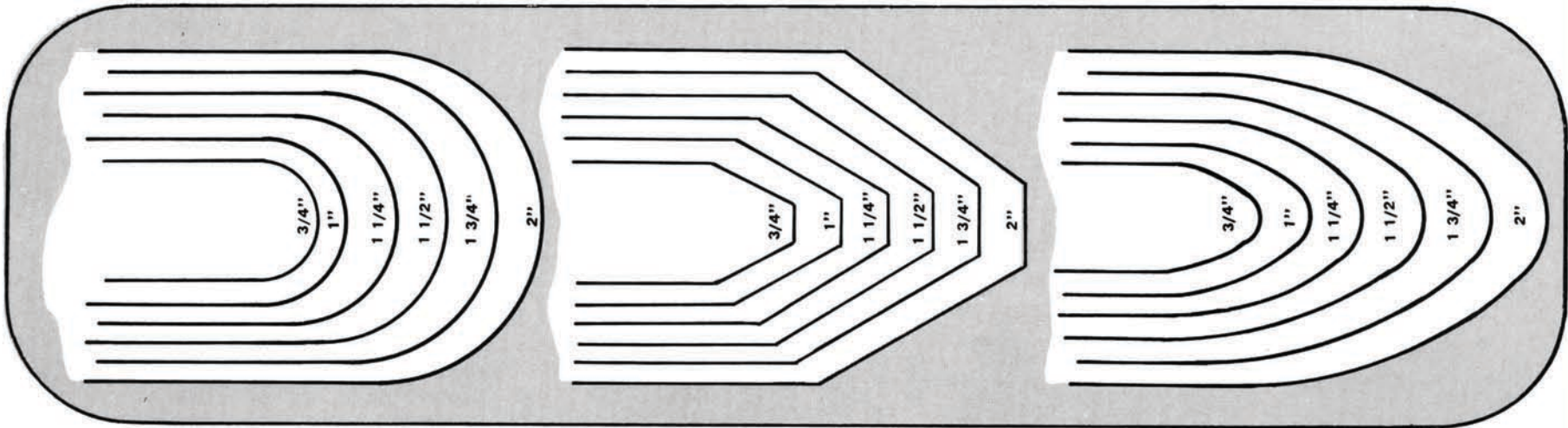

HOW TO MAKE A LEATHER KEEPER OR LOOP

Step 1. To determine the correct length to cut loop ... fold around belt as shown in illustration. Allow one thickness of belt leather as shown, then sew or staple loop together.

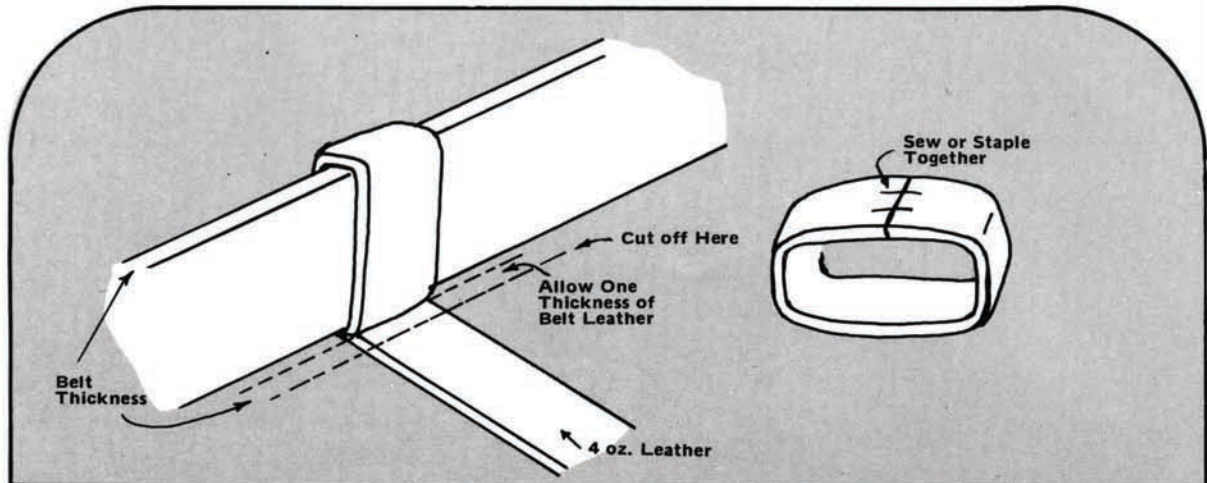

skiving belts

Step 1. Use a 1574 Safety Beveler to skive the buckle end of belt to reduce the thickness of leather where the buckle will be attached.

Step 2. With the skiving knife, skive about 1/3 the thickness of the flesh side of the buckle end. Use care to skive a uniform thickness. You may also wish to skive the tip so it will be easier to thread through pant loops and belt keeper.

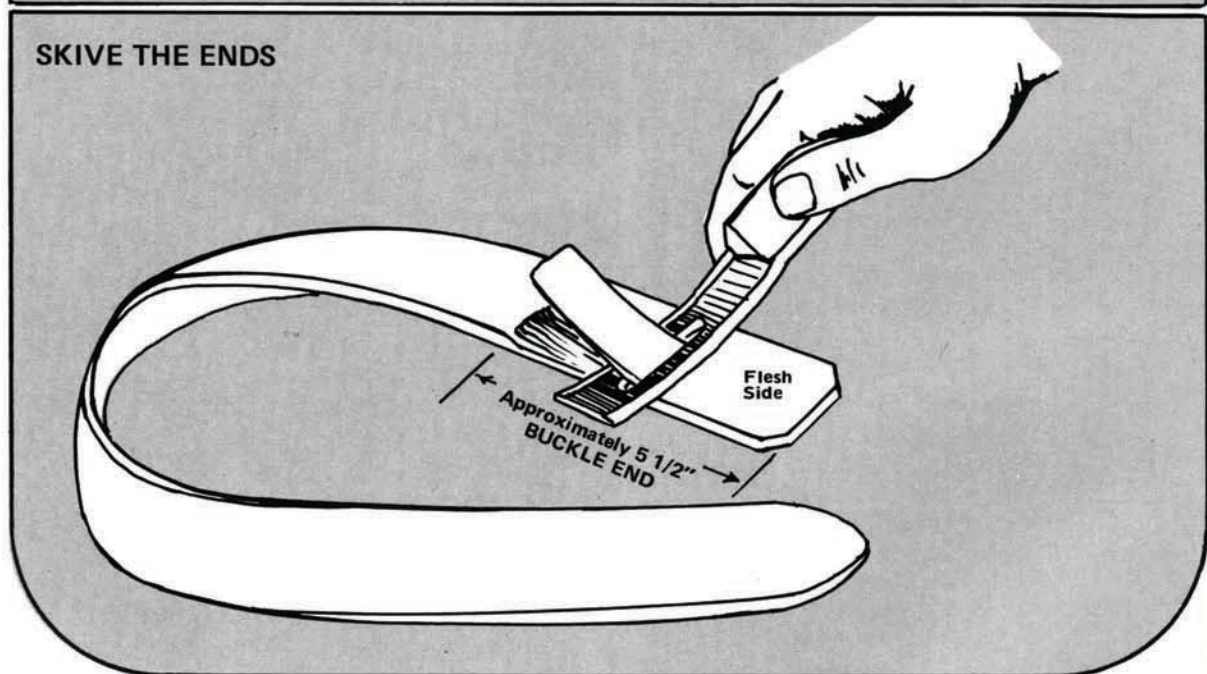

punching

Step 1. After belt has been sized, punch holes for the buckle slot, snaps and buckle tip.

Step 2. Locate the snap and slot holes as shown. Punch snap holes with a Size 6 and a Size 2 as indicated. Use a Drive Punch or Rotary Punch. Punch the slot with 3/4" Bag Punch.

Step 3. Locate the tip end holes as shown, and punch holes the size needed to fit the buckle tongue or hook with a Drive Punch or Rotary Punch. Usually a Size 2 or 3 will be the proper size.

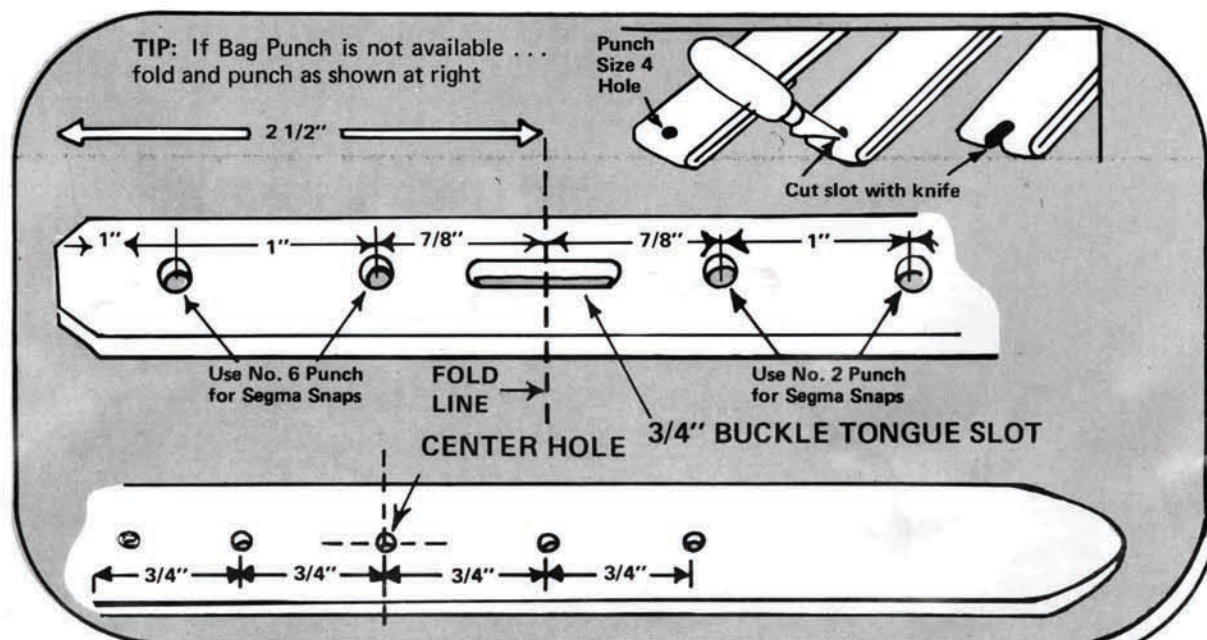

setting belt snaps

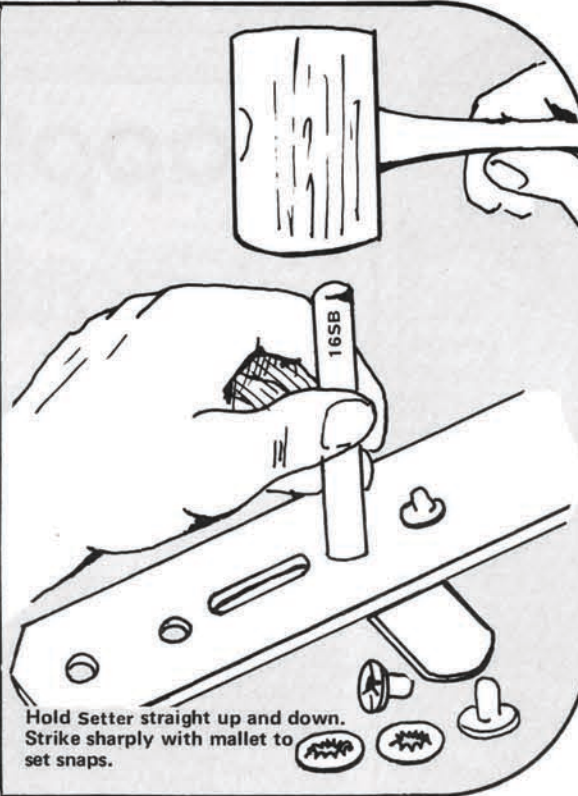
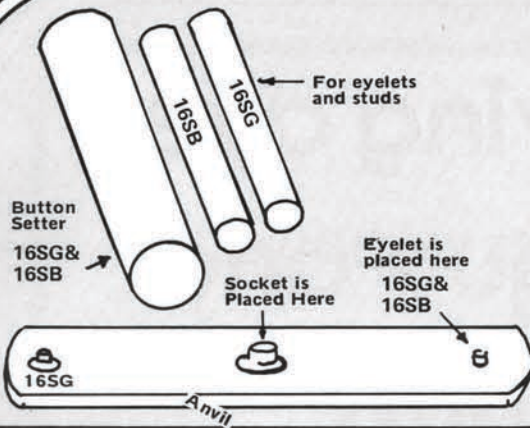

Hold Setter straight up and down. Strike sharply with mallet to set snaps.

Use the 8103 Craftool Sigma Snap Setter and a mallet to set the belt snaps as shown.

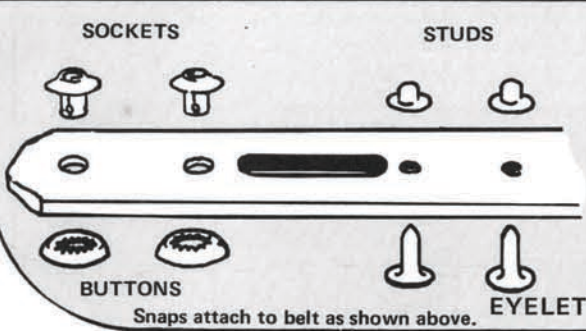

edging belts

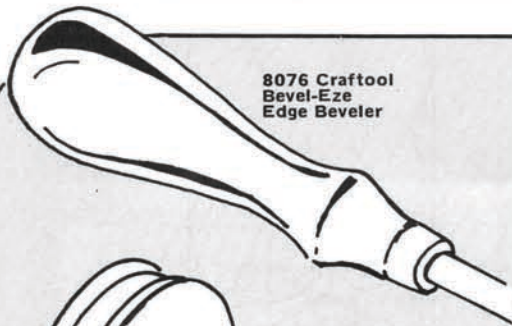

8076 Craftool Bevel-Eze Edge Beveler

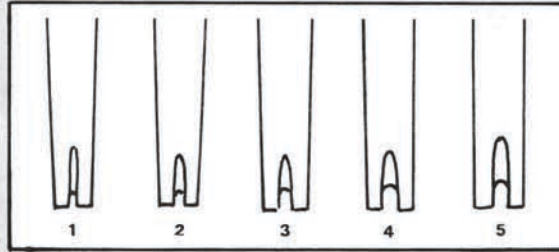

8122 Craftool Edge Slicker

This tool is designed for burnishing the edges of the leather where a smooth edge is desired . . . after the edge is beveled.

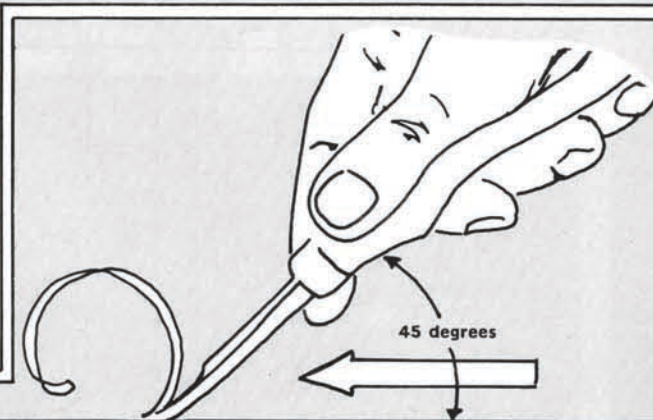

For a more professional, more attractive appearance, edge your belts with an 8076 Craftool Bevel-Eze Edge Beveler, and then burnish the edges with an 8122 Craftool Edge Slicker.

Note: Craftool Edge Bevelers are available in sizes 1, 2, 3, 4 and 5. Size 1 beveler cuts a narrow, shallow bevel, and as the size numbers increase, the width and depth of the bevel increases. Size 2 or size 3 is recommended for edging belts.

EDGE BEVELING IS USUALLY THE FINAL STEP AFTER ALL CARVING HAS BEEN COMPLETED.

Step 1: The Craftool Edge Bevelers are safe to use. They are designed to cut only when held at the proper angle. This angle is approximately 45 degrees. They cannot cut too deep.

Step 2: For best results, hold work firmly on bench with free hand. Use firm pressure on tool held at proper angle, and make edge-bevels quickly. A good bevel is indicated by one continuous "string" of leather from the beveled edge.

Step 3: Moisten the dyed edge of the leather with a sponge dipped in water, and rub briskly back and forth with the edge slicker. Hold project firmly.

FRONT VIEW Showing the proper edge angle of the tool.

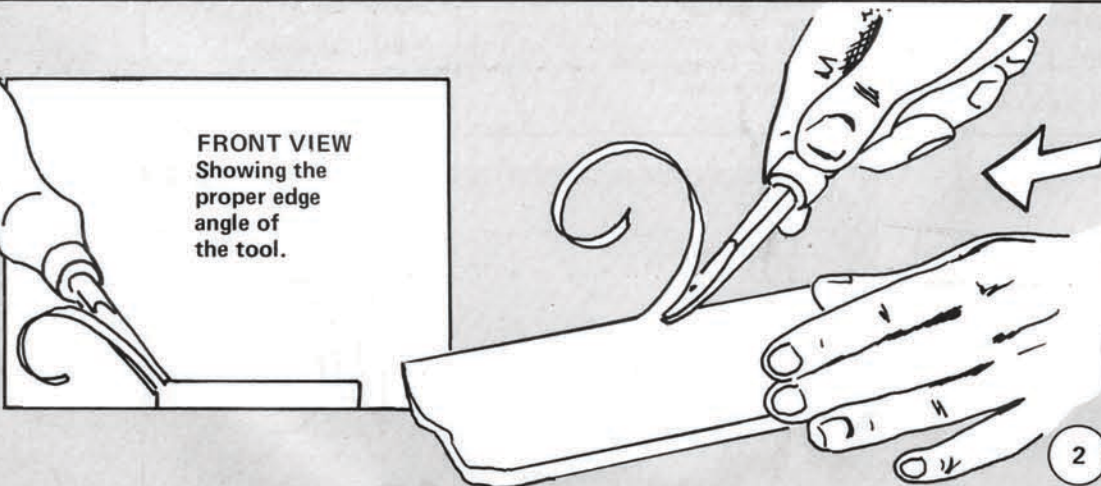

BURNISH THE EDGES After edge beveling

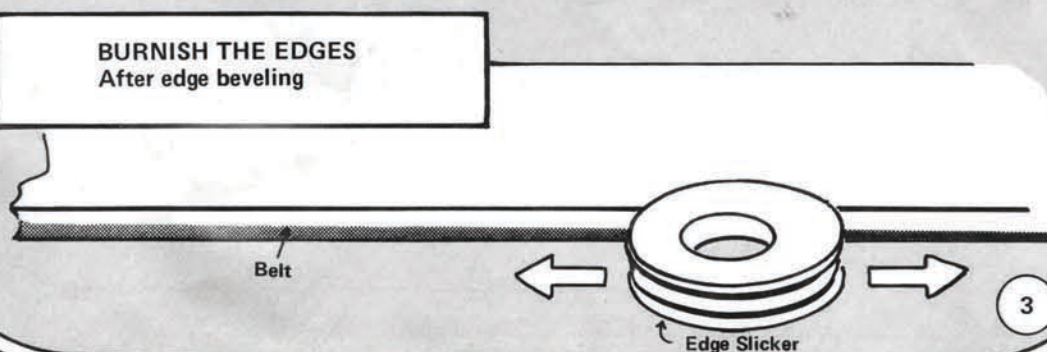

installing keeper and buckle

Fasten snaps . . . belt is ready to wear!

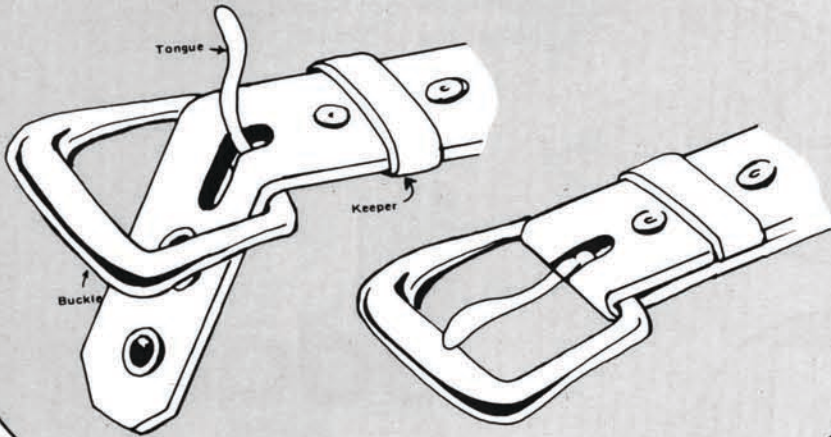

applying dye, antique and finish



Fiebing's Antique Finish is recommended for imparting a beautiful two-toned patina to Live Oak Cowhide. It comes in a choice of five rich colors.

These supplies are recommended for use with Fiebing's Antique Finish:

- Sponge for application
- Plastic gloves
- Fiebing's Antique in the color of your choice



Omega Dye is suggested for solid, background and Nature-Tand dyeing. It is just the right consistency for creating the burnished effect on Nature-Tand stamping without dyeing the impressions themselves.

These supplies are recommended for use with Omega Dye:

- Sponge and cloth for application
- Plastic gloves (if desired)
- Omega Dye in the color of your choice



Omega Dye is recommended for coloring in the background portion of tooled leather belts. Darkening the background by this method makes the tooled design stand out beautifully in contrast to the dark background.

These supplies are recommended for use with Omega Dye:

- No. 2 Dye Brush
- Omega Dye in the color of your choice



Cova Dye is recommended for dyeing flowers and leaves in Nature Designs on Nature-Tand leather.

These supplies are recommended for use with Cova Dye:

- No. 2 Dye Brush
- Cova Dye in the color or colors of your choice



Recommended Finishes for your leathers:

- For Natural tooling leathers, use Neat Lac or Finish Coat

- For Nature-Tand leathers, use Carnuba Cream or Finish Coat

belt design by al stohlman



belt design by al stohlman

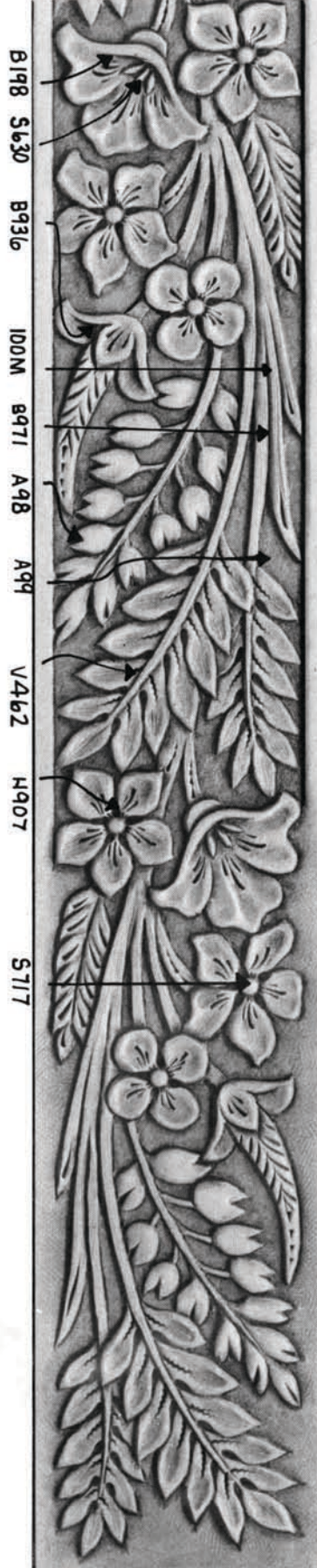
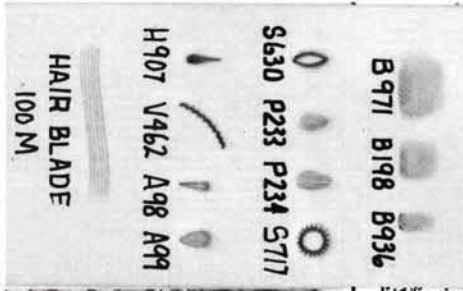

belt design by al stohlman

ACANTHUS SCROLL

B971 B198 B936

S864 P234 H904 H903

H907 U852 A104

HAIR BLADE
100 L



belt design by al stohlman

MORNING GLORY

B971 B198 B936

P973 P217 P234

S630 V749

A104



belt design by al stohlman

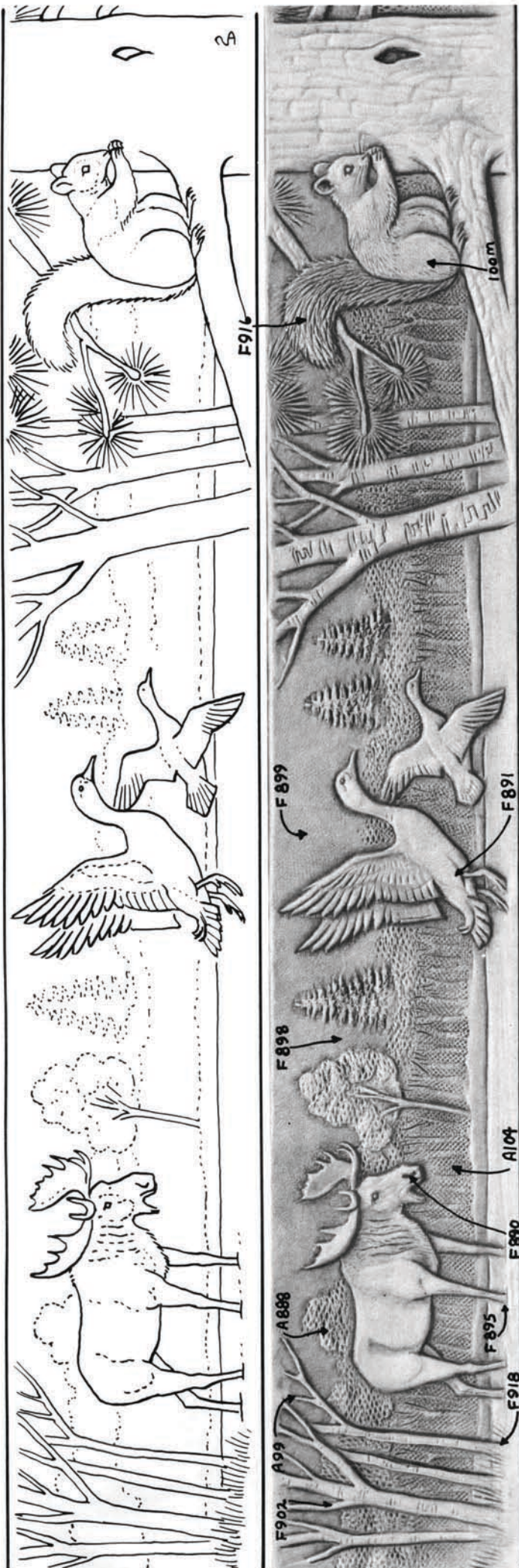

belt design by al stohlman

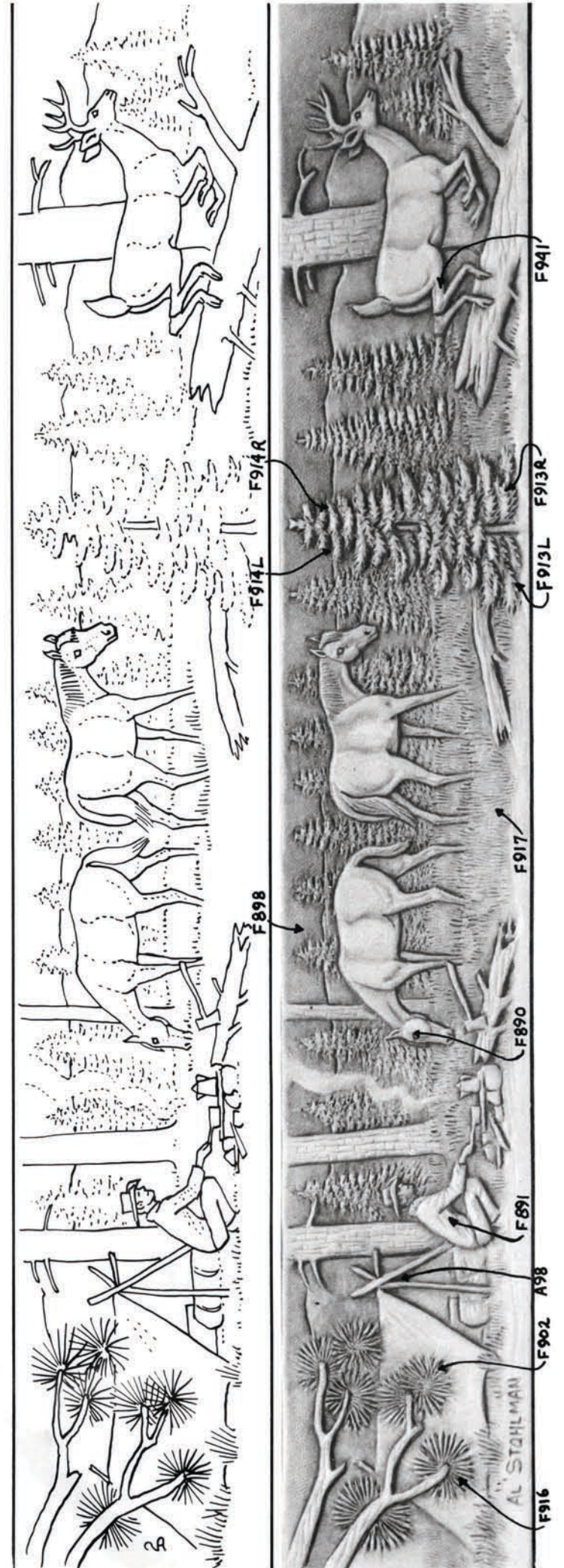

belt design by al stohlman

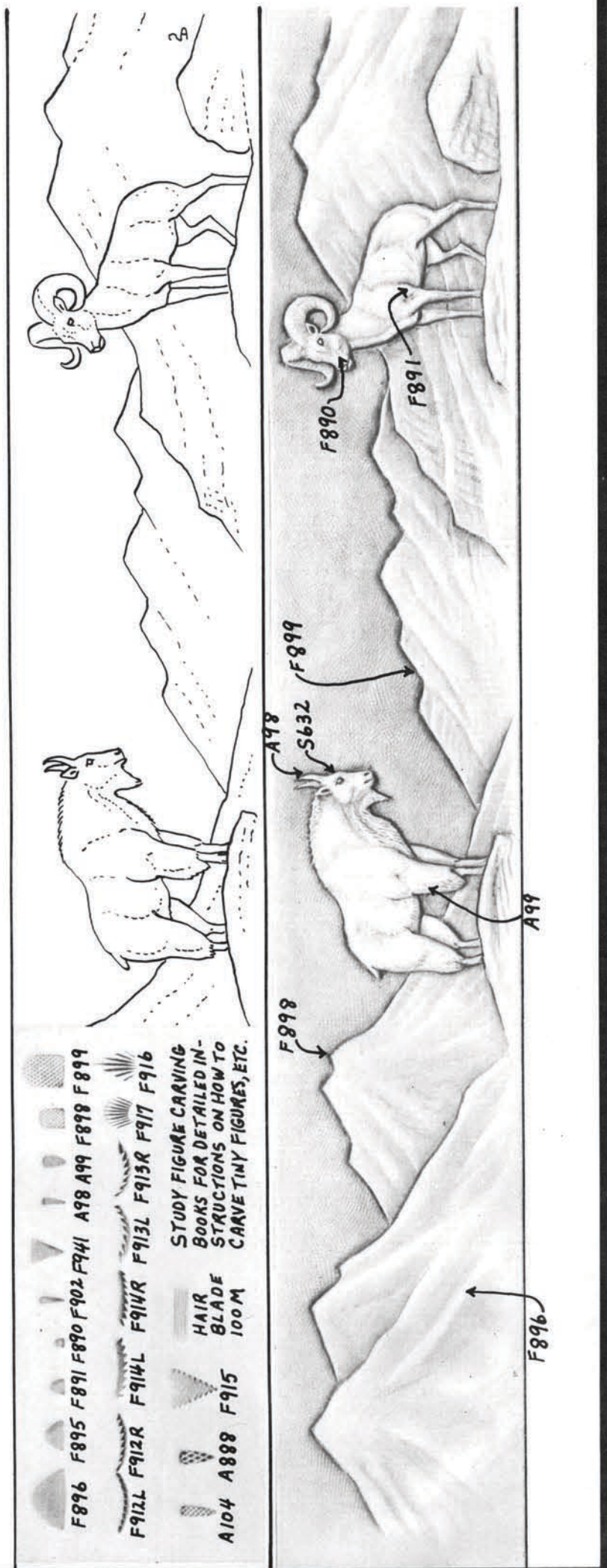

belt design by al stohlman

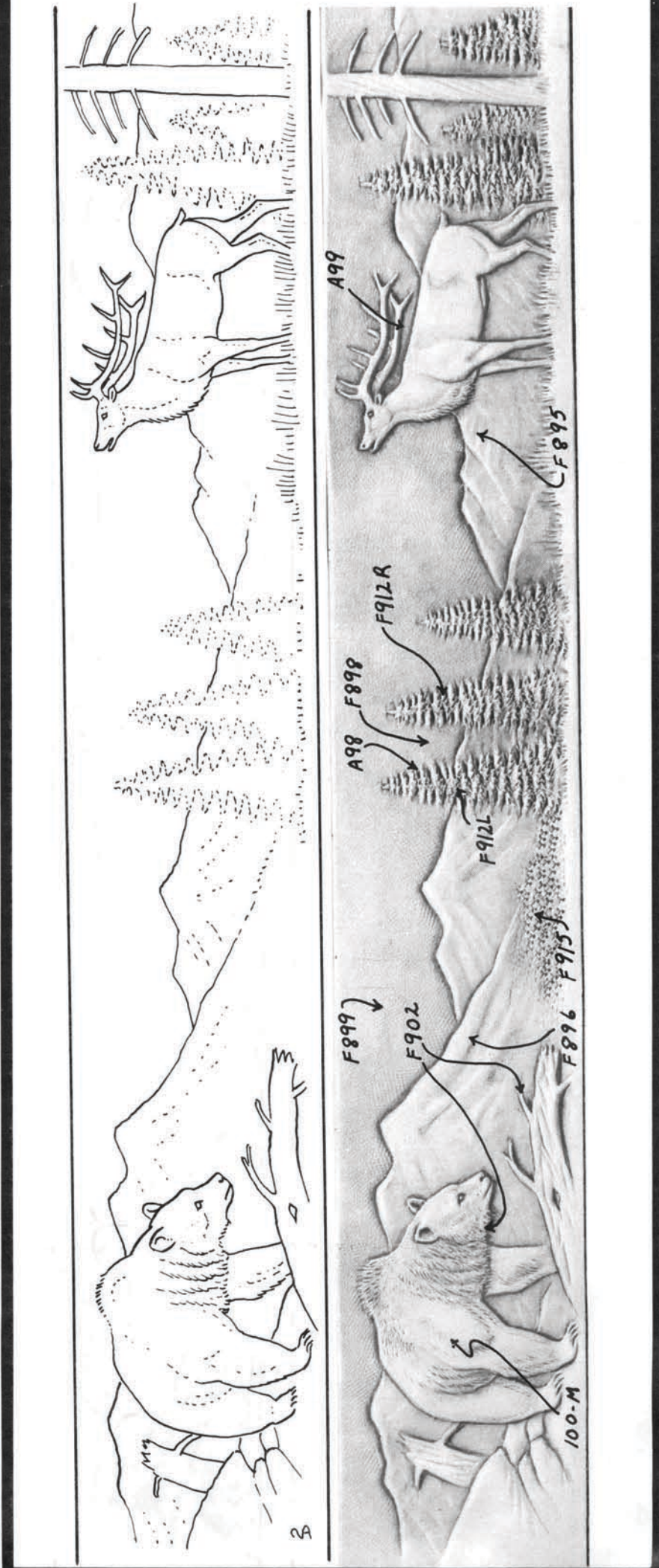

belt design by jerry jennings

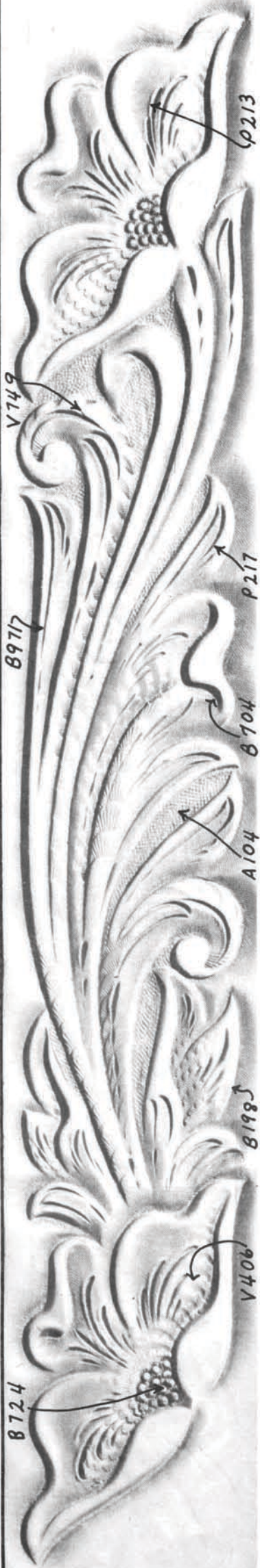

belt design by jerry jennings



belt design by jerry jennings

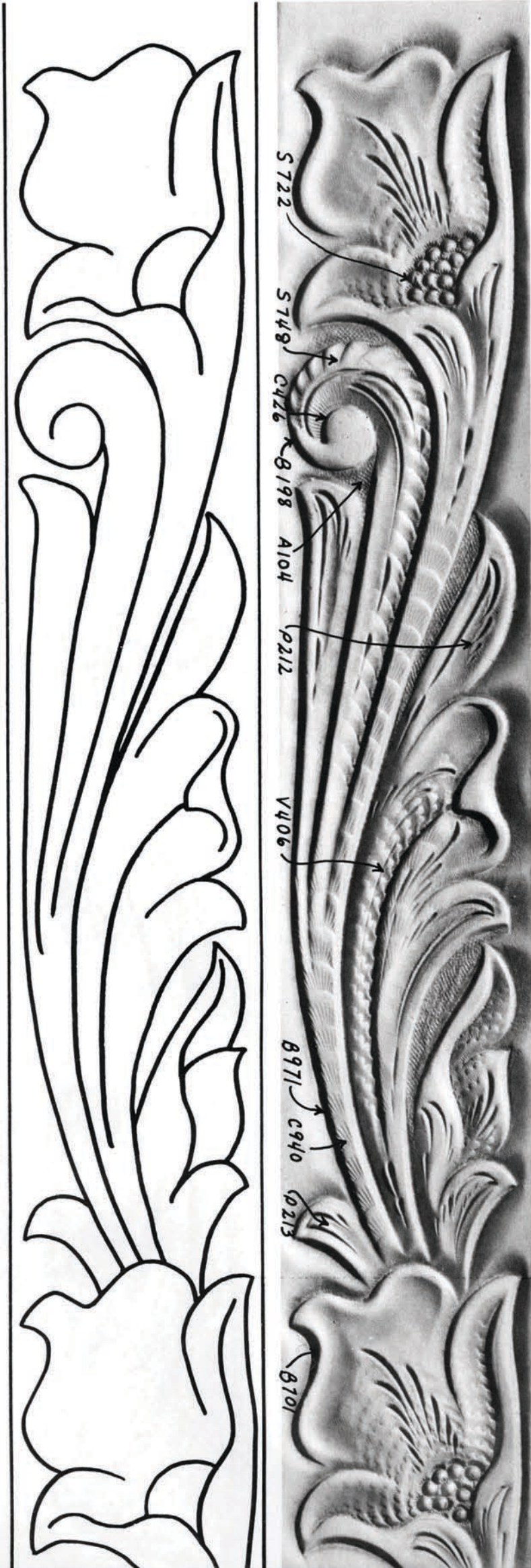

belt design by jerry jennings

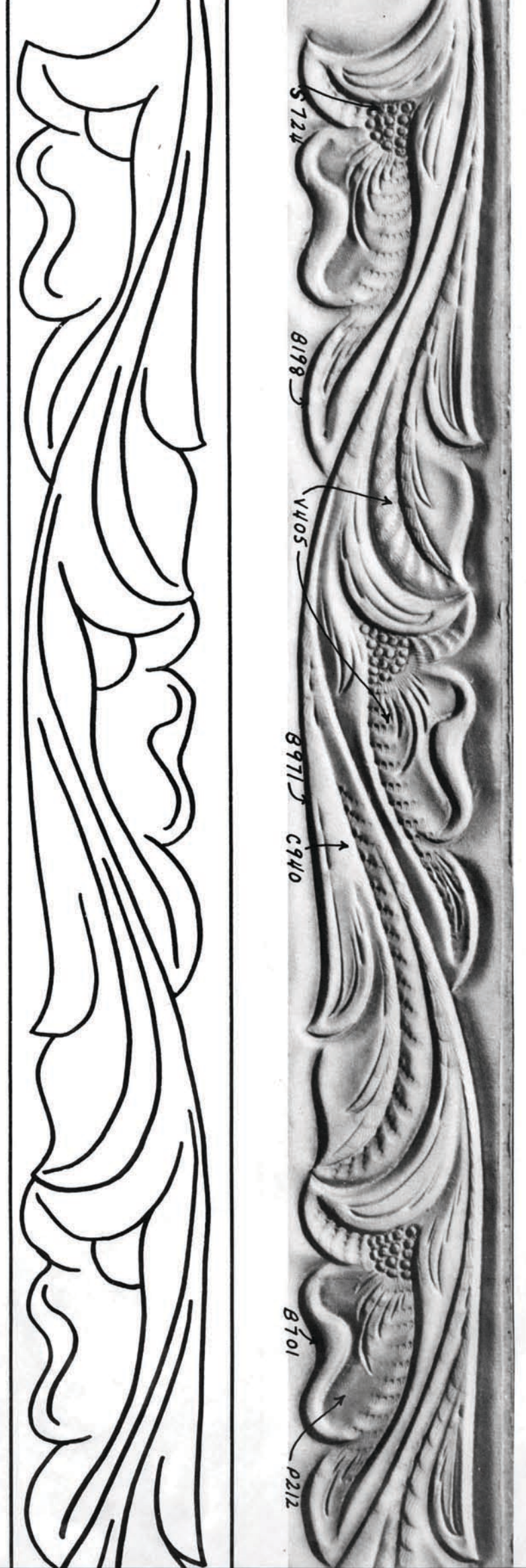

nature designs for leather belts

by jerry jennings

pages 15 to 25 show 33 exciting nature design ideas for decorating belts

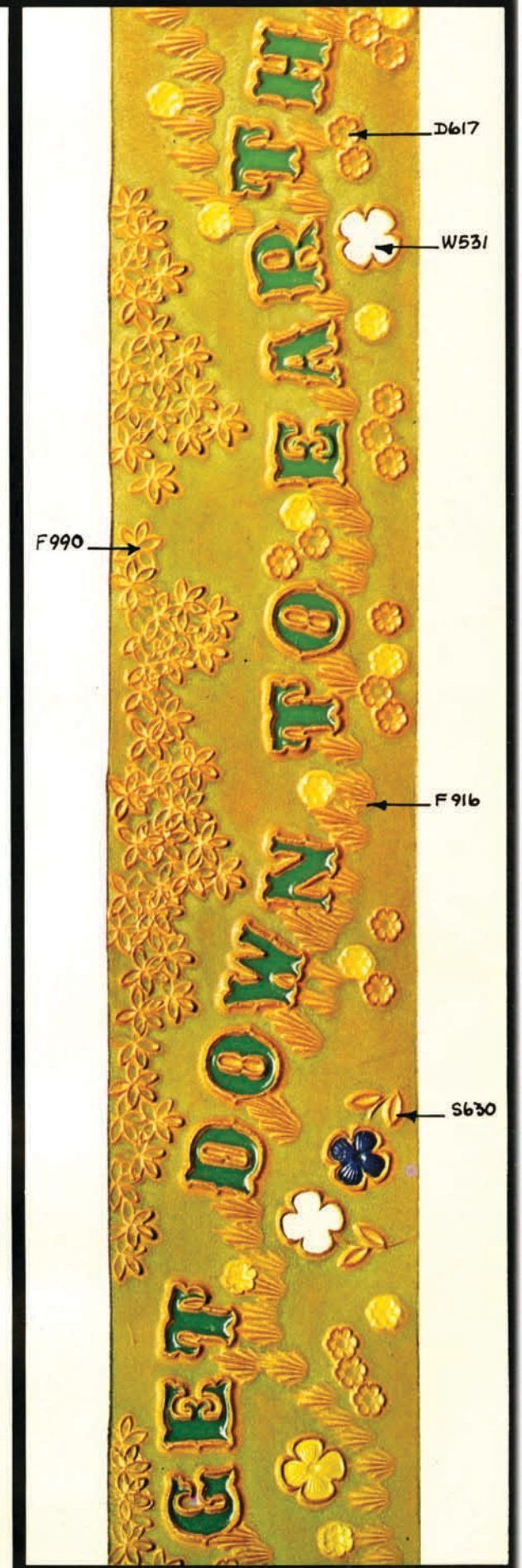
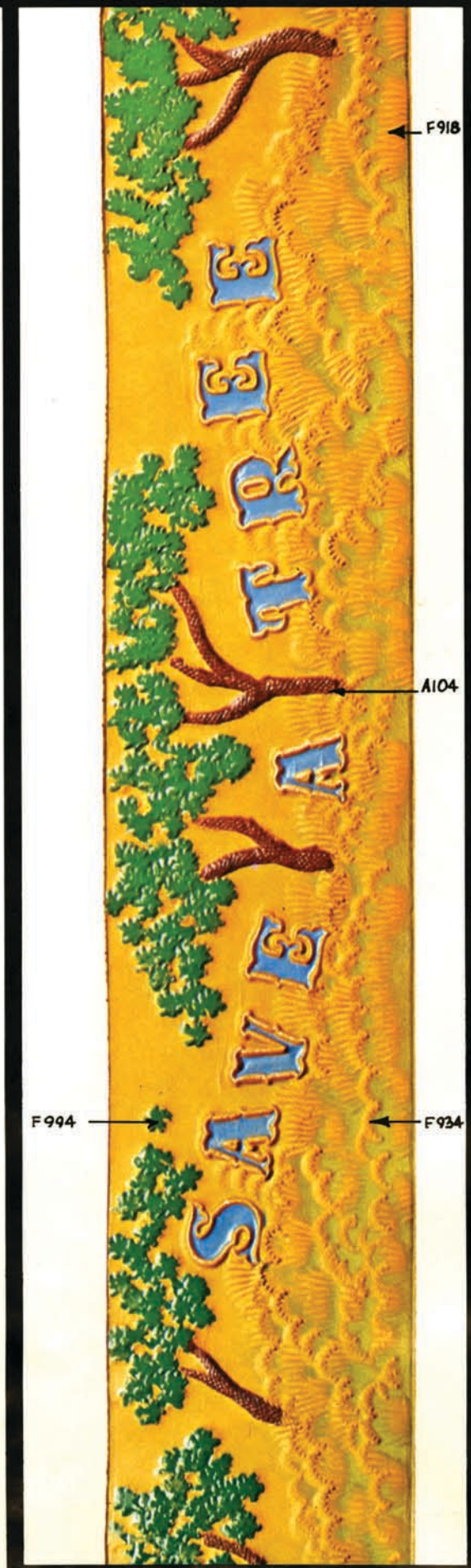
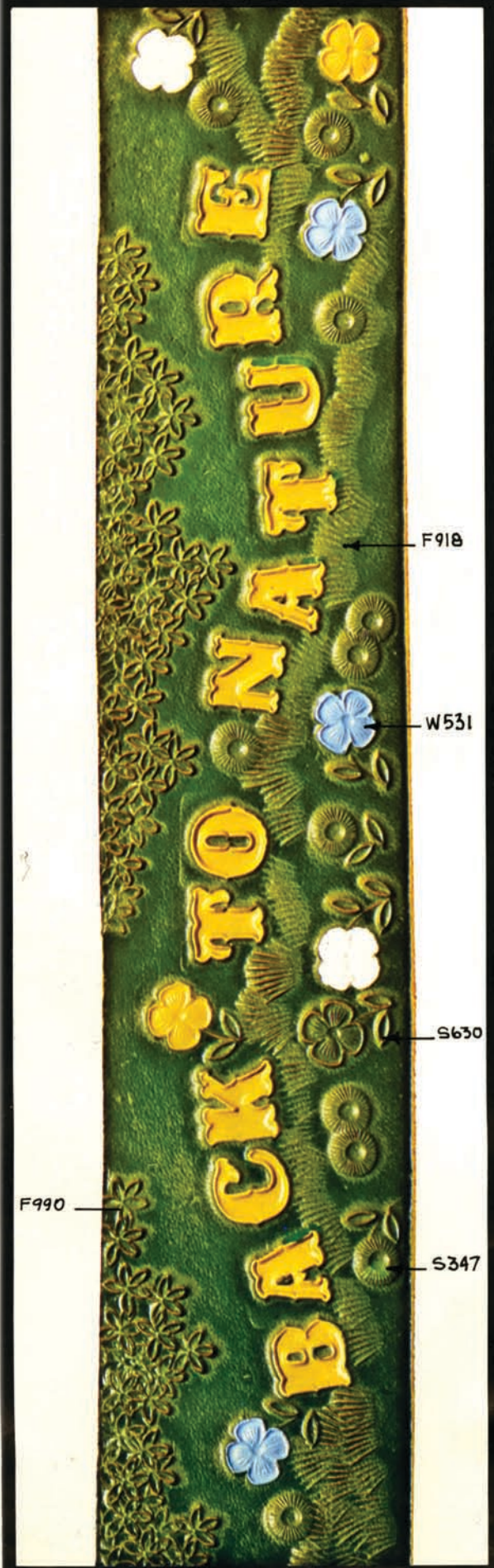

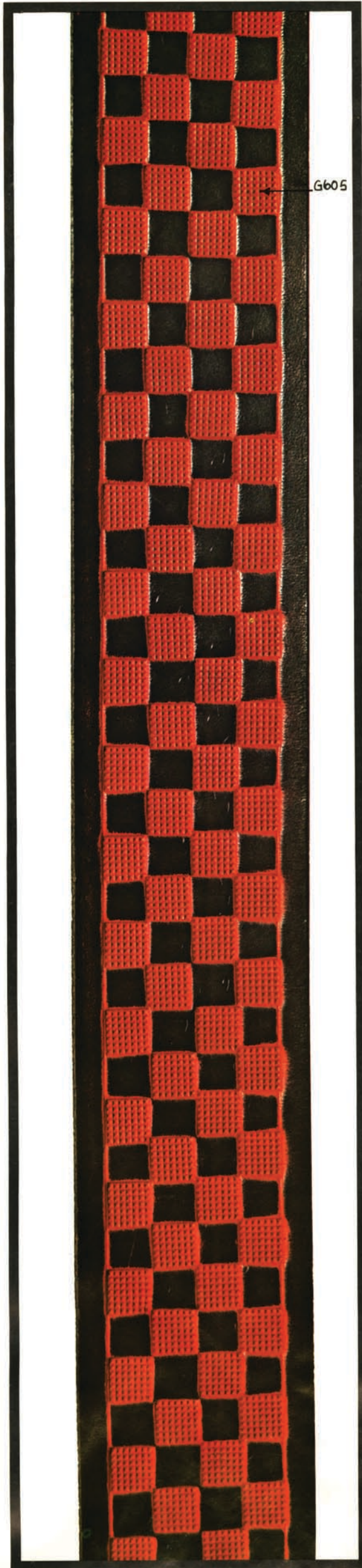

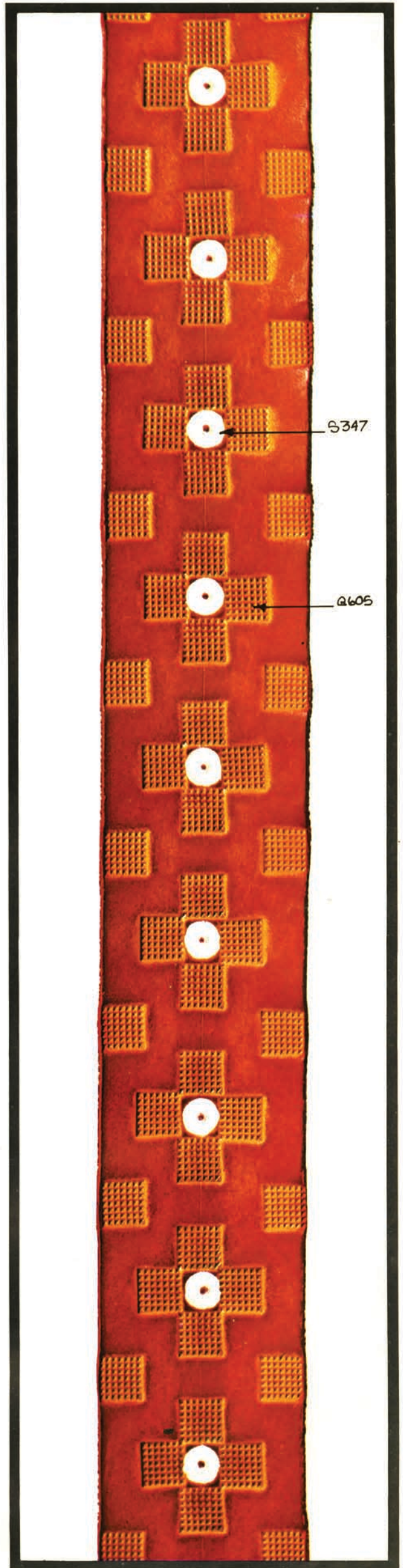
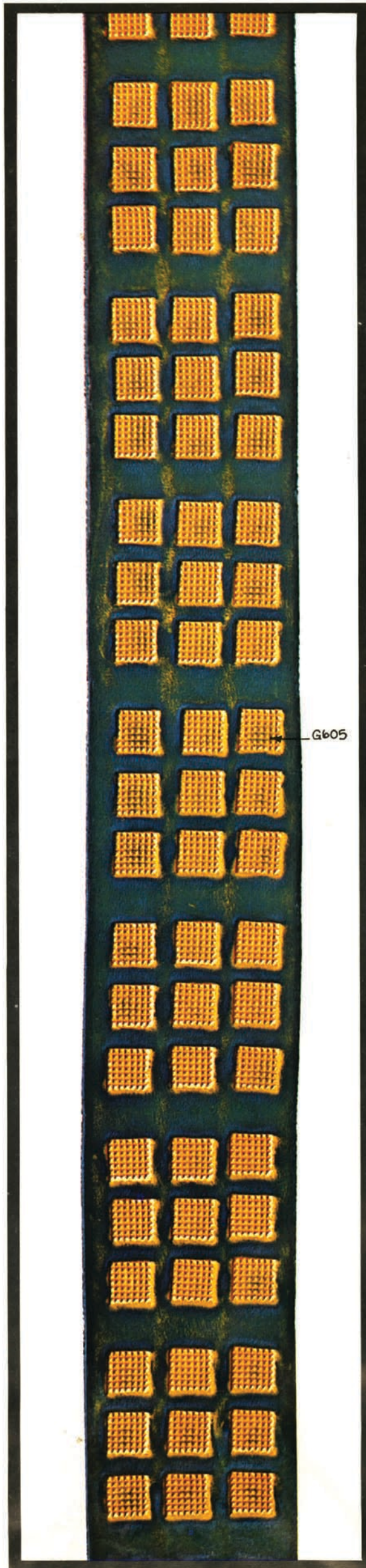
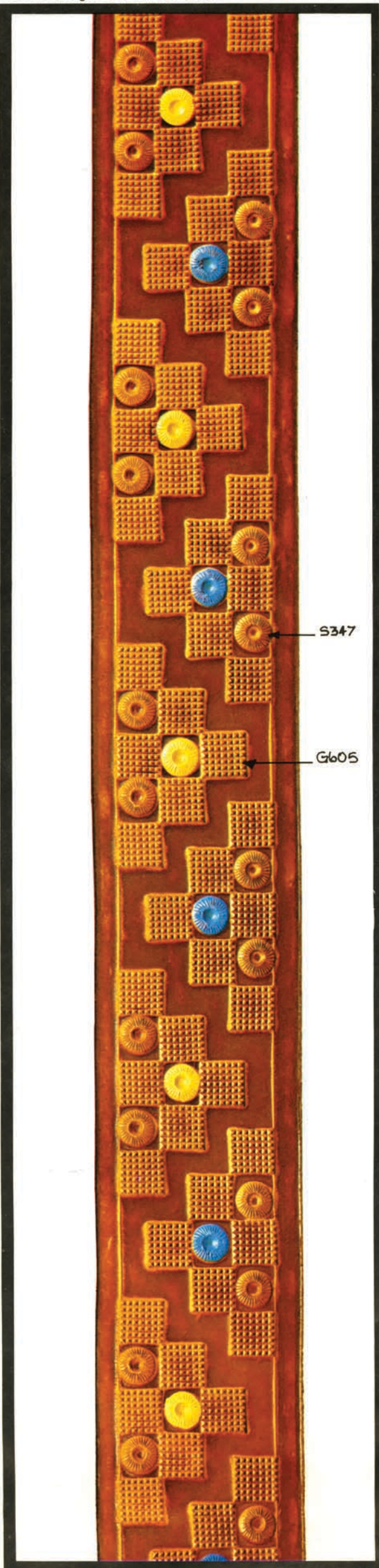

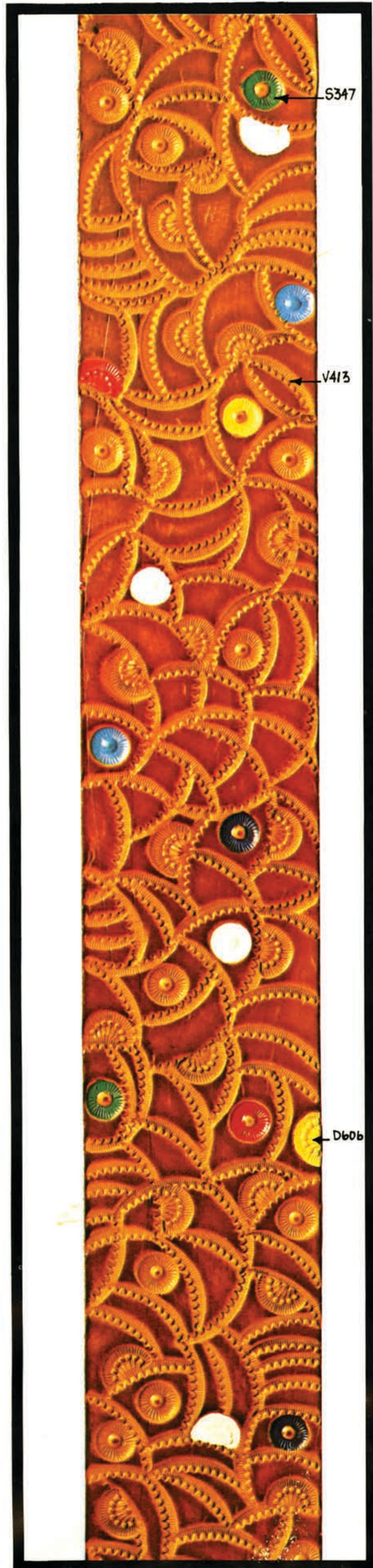
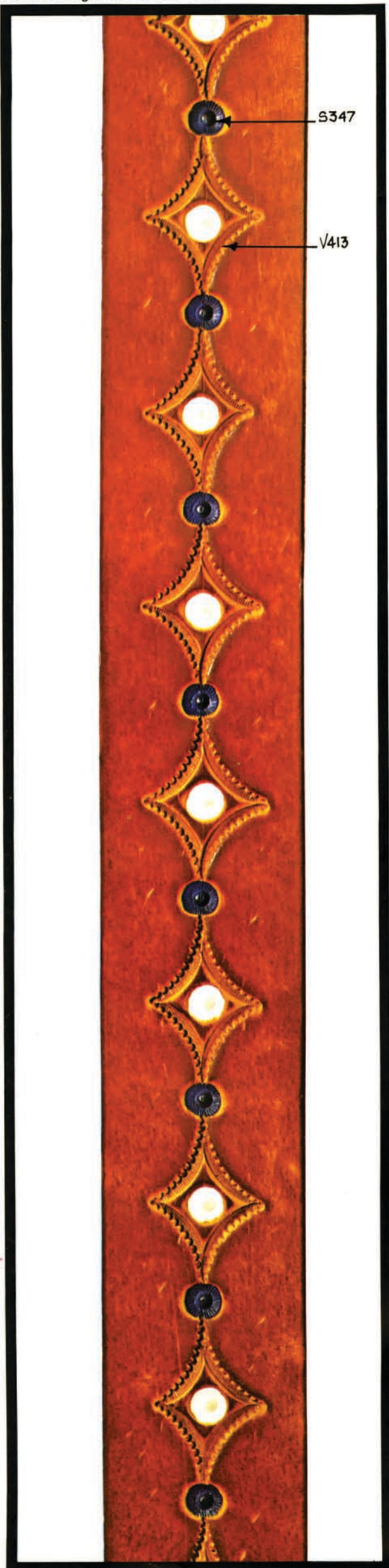

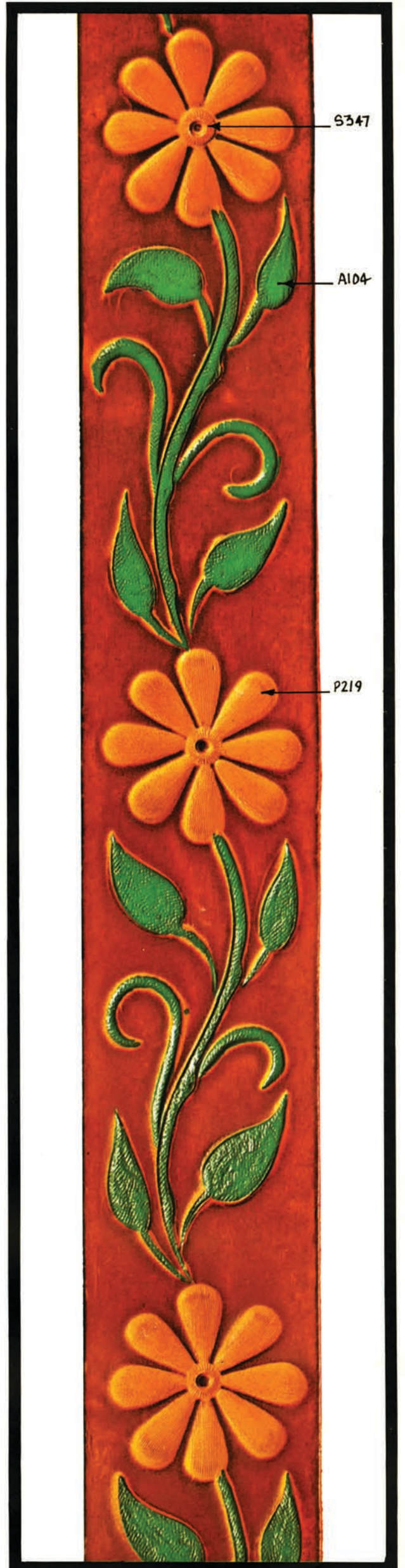
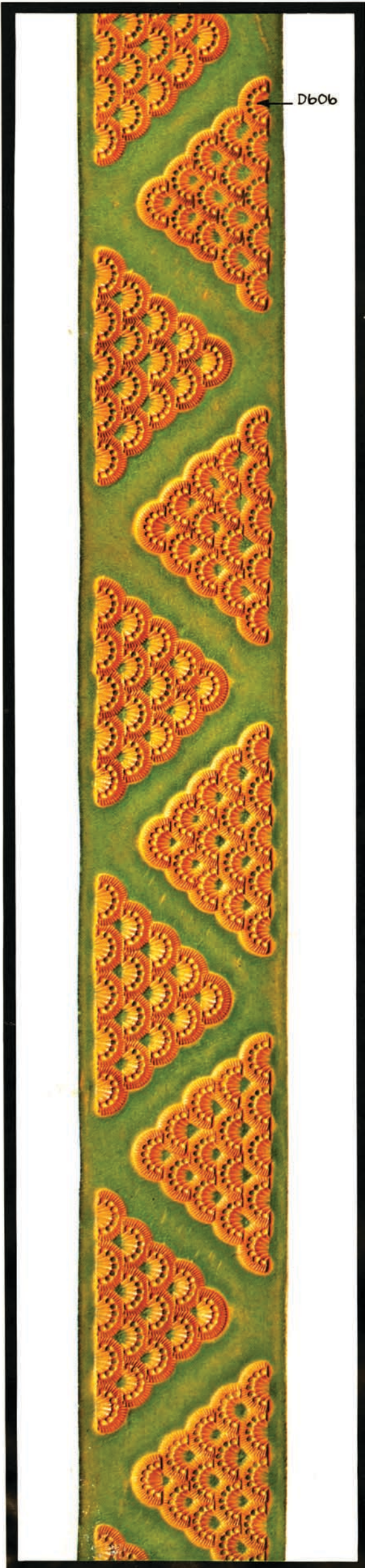
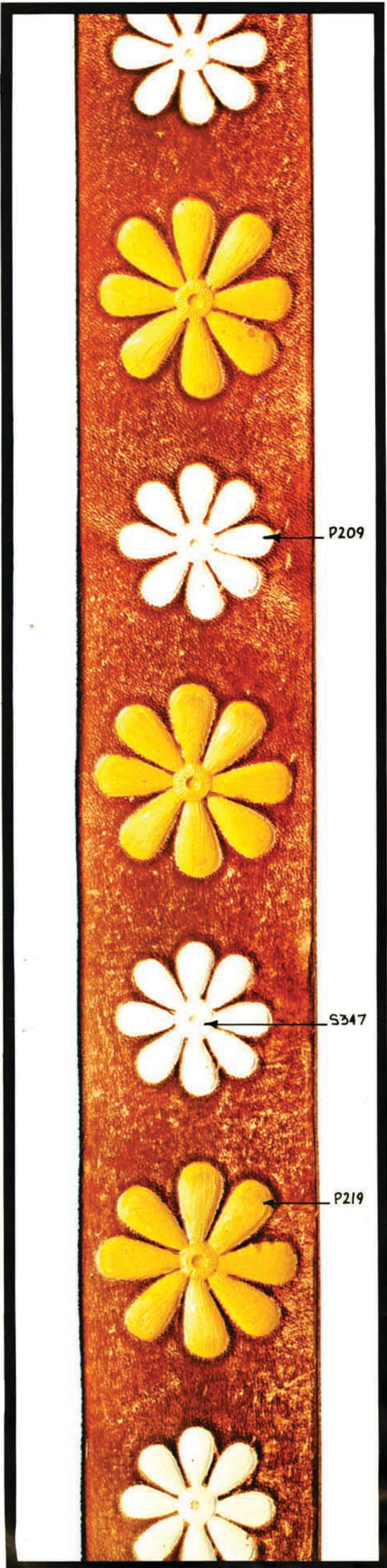

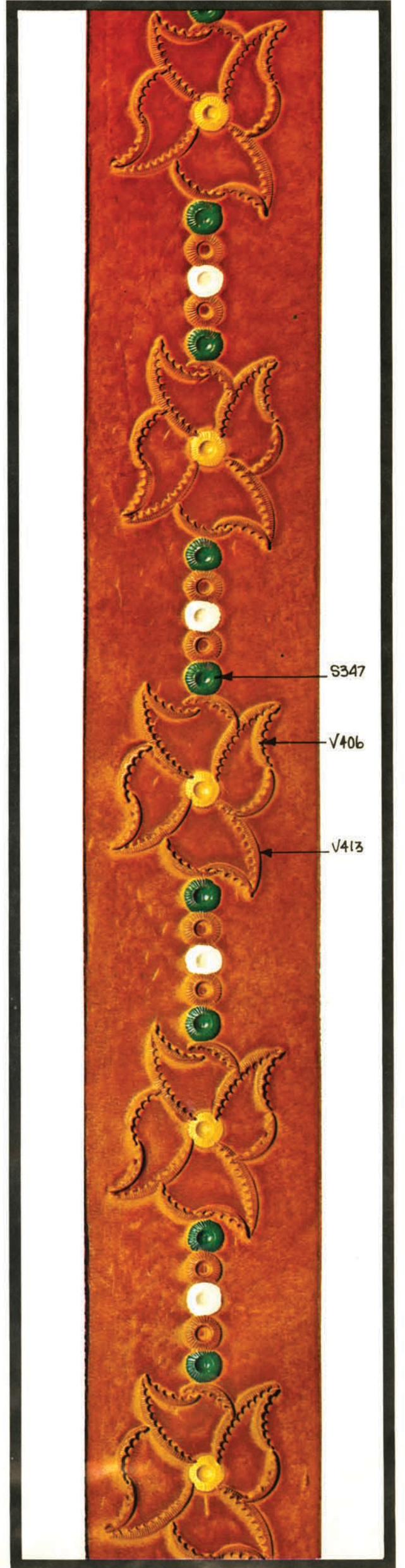
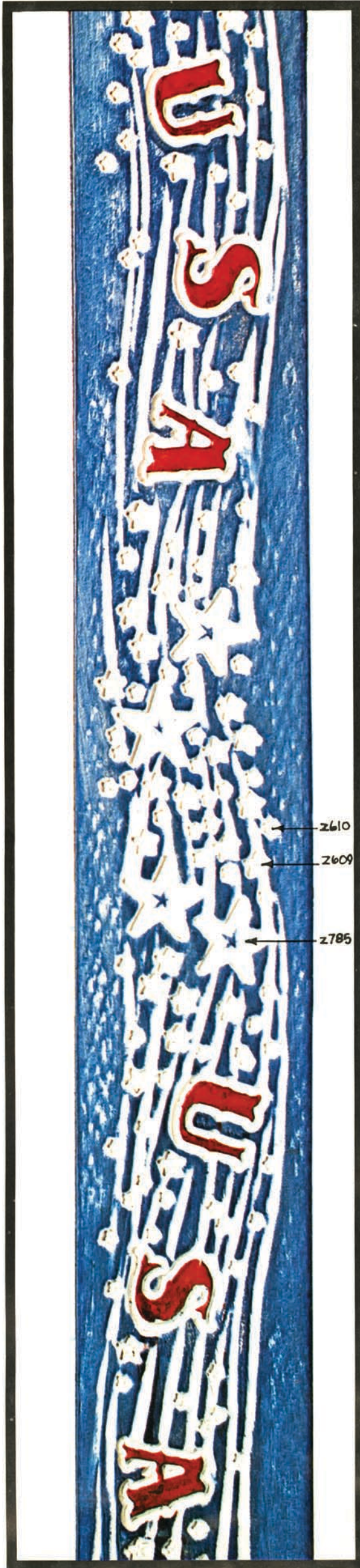
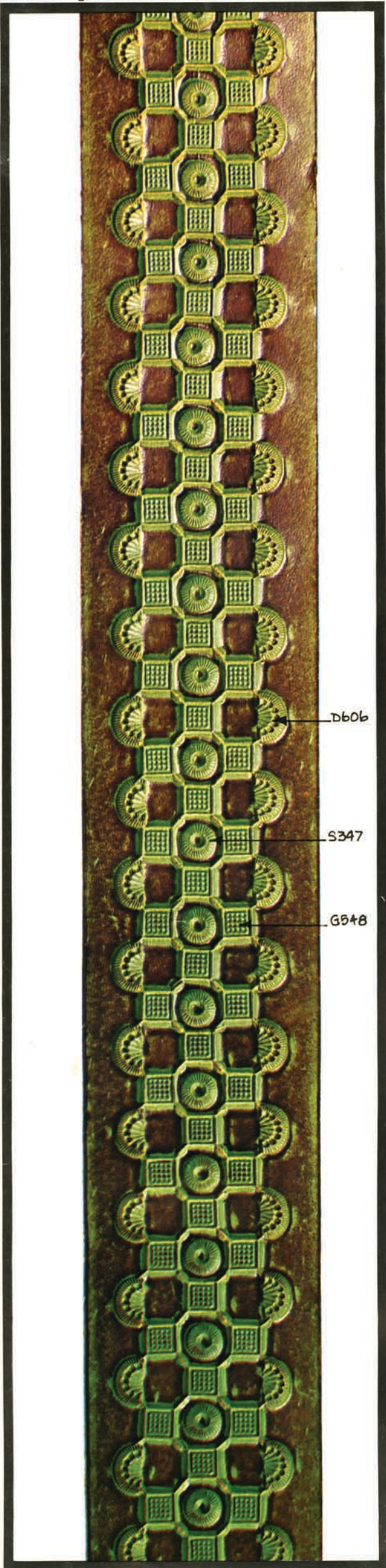

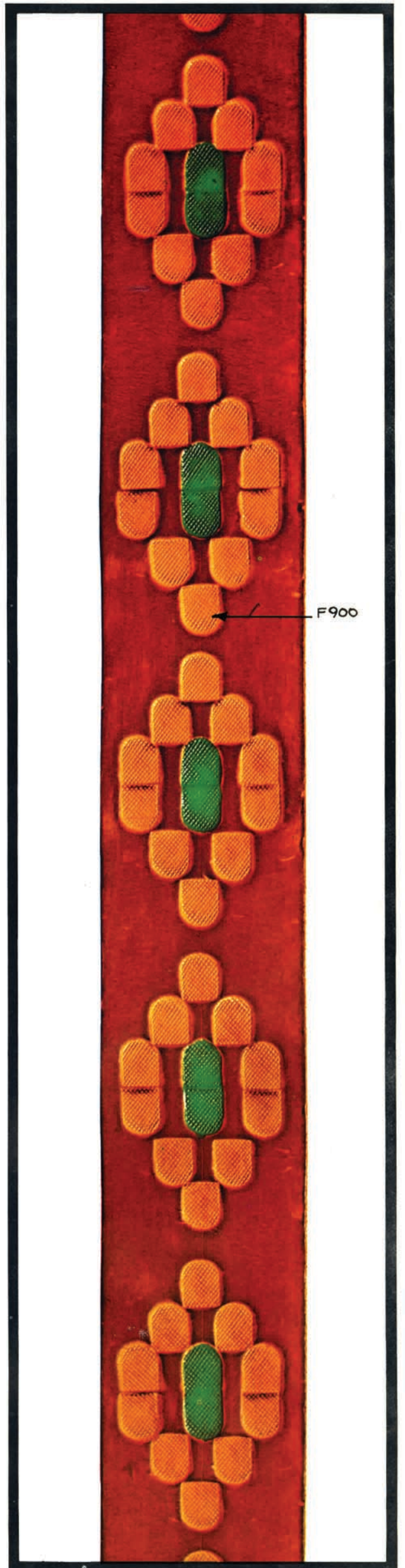
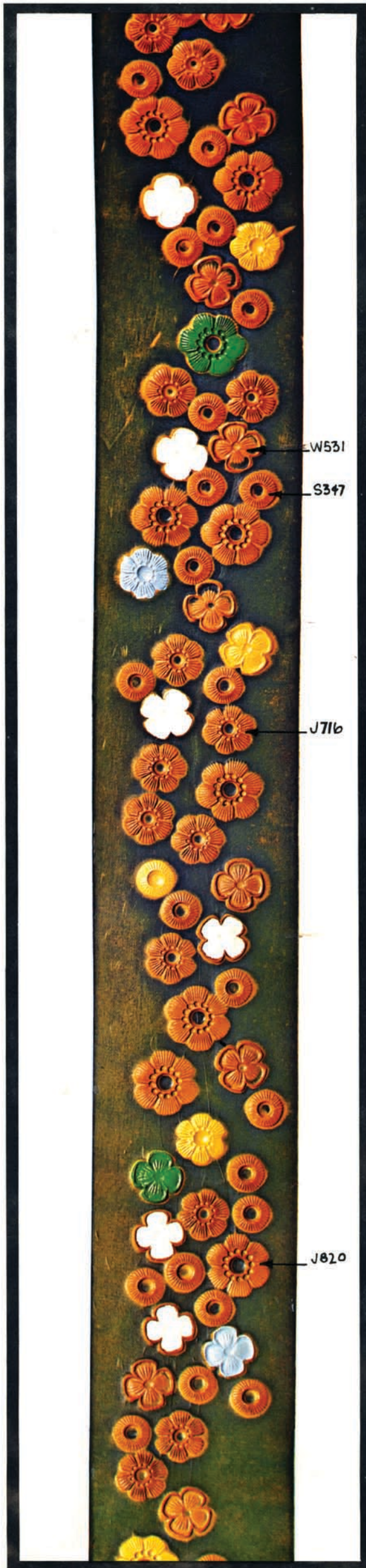
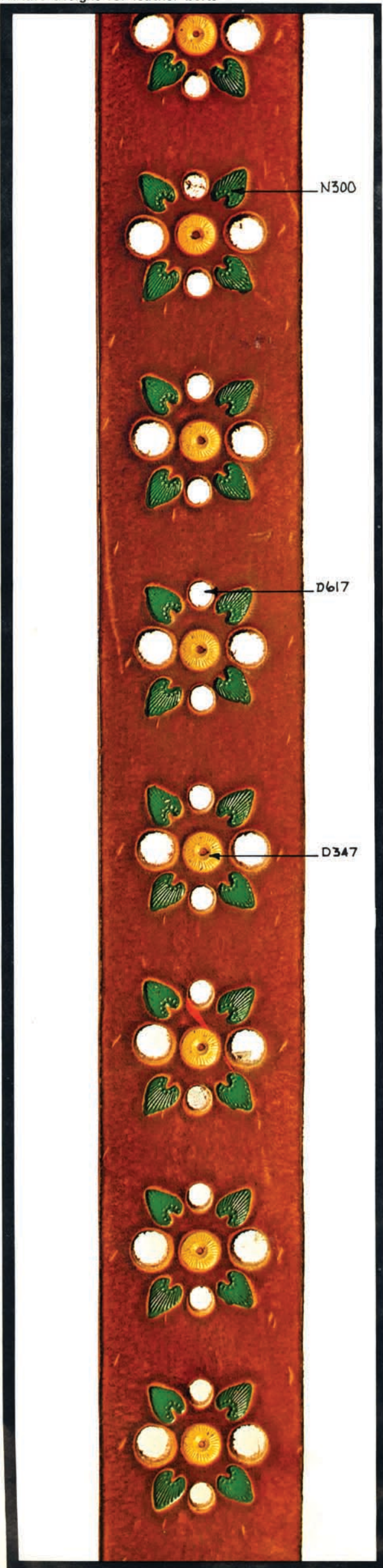

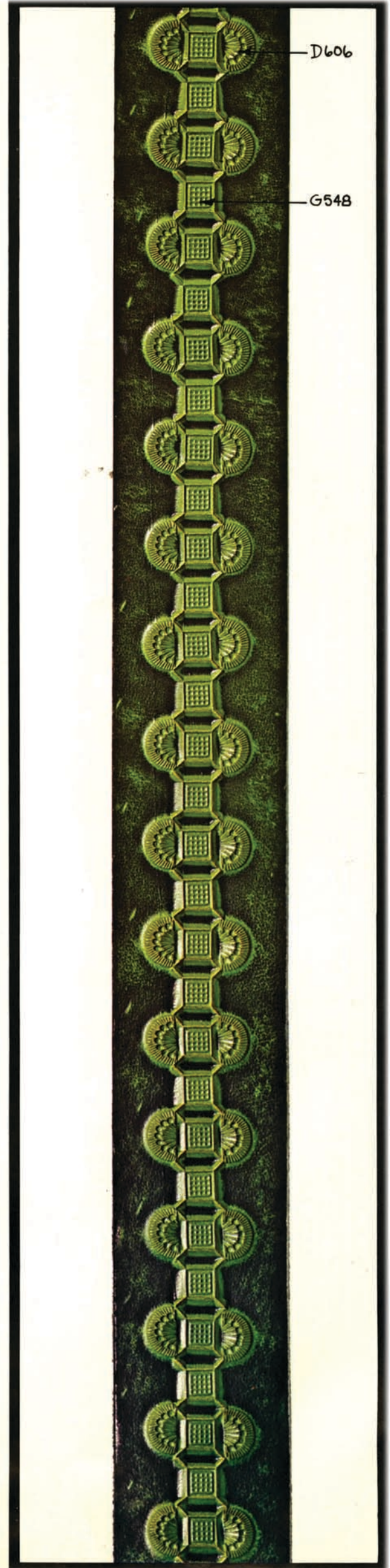
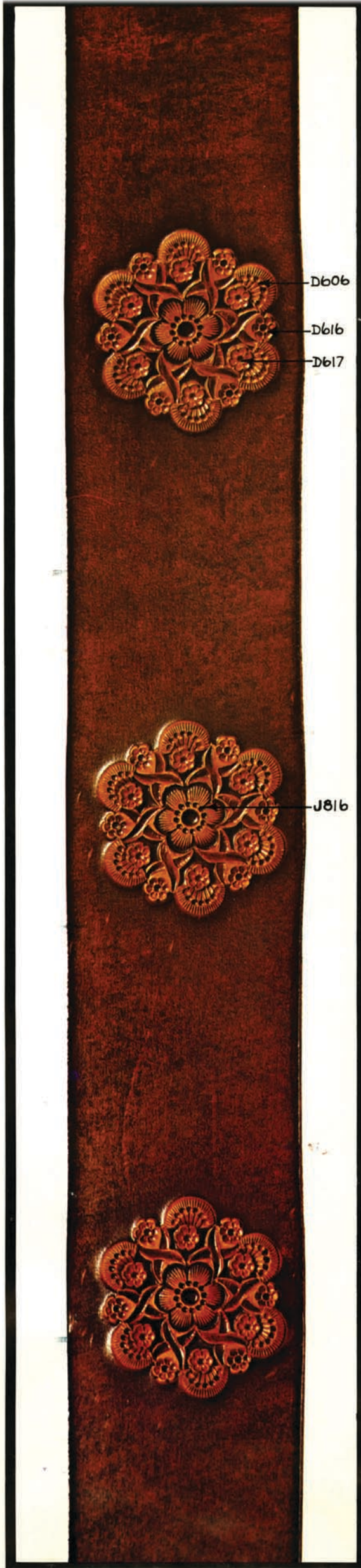



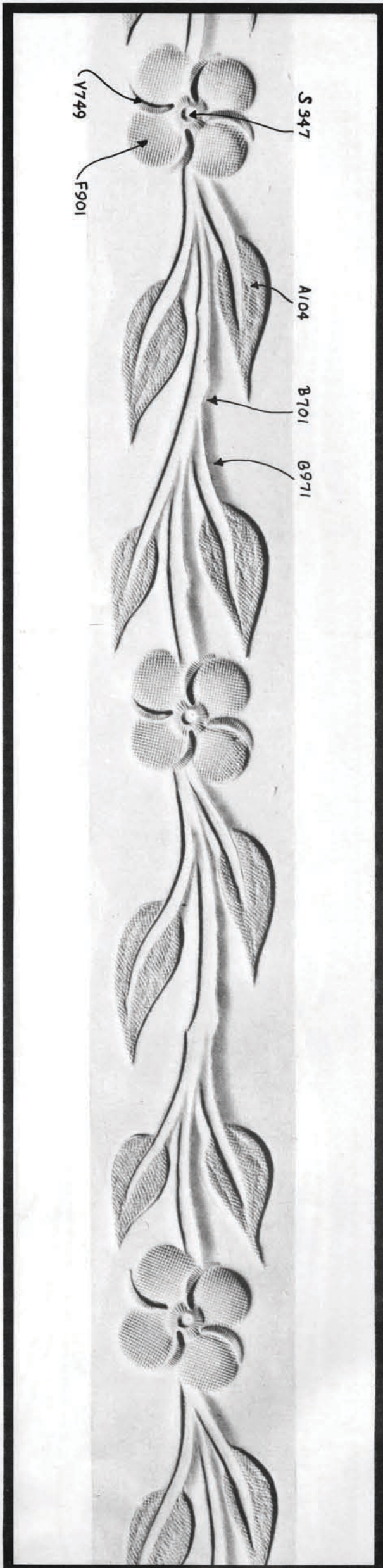
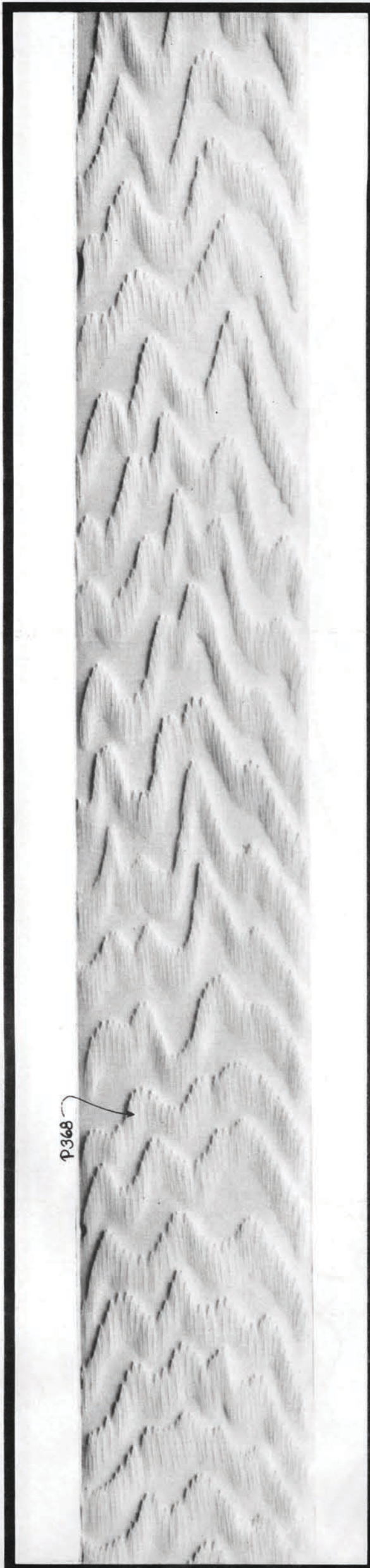
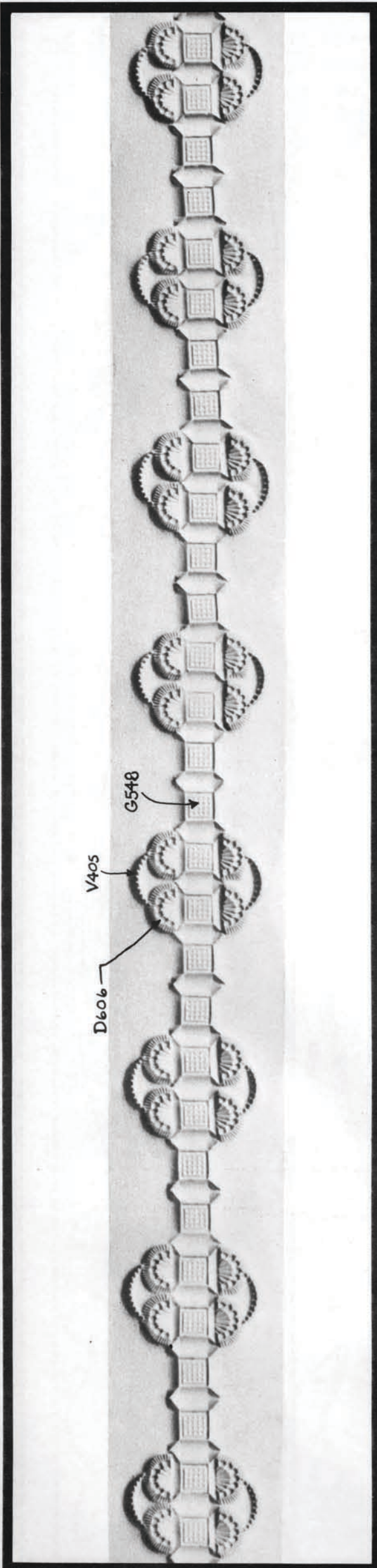

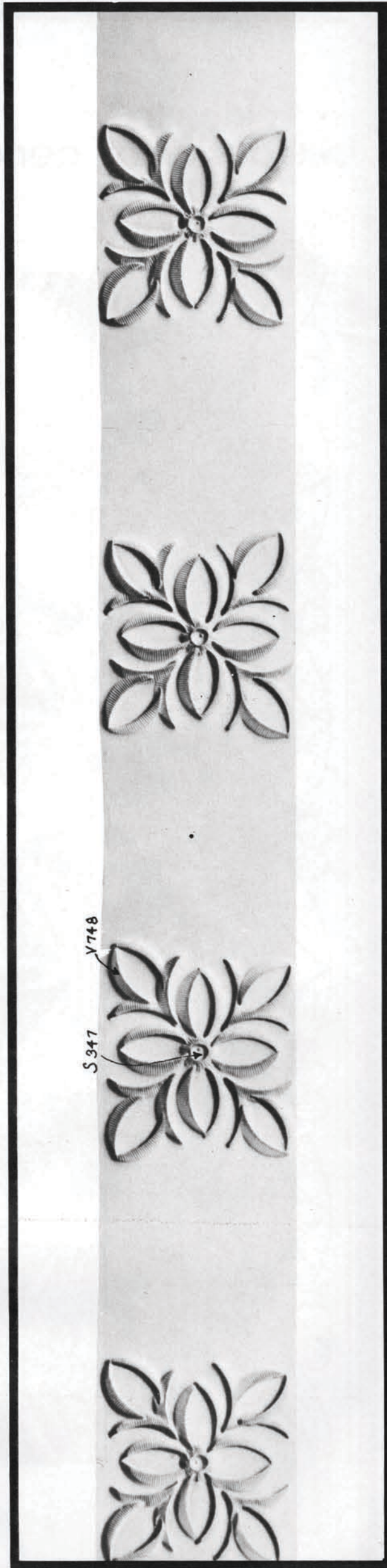
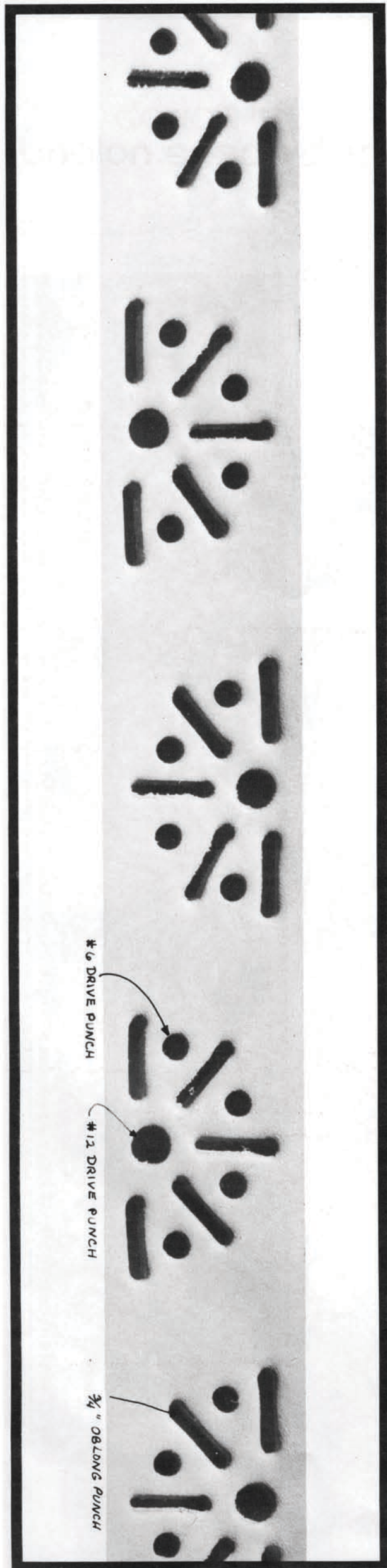

belt design by gene noland

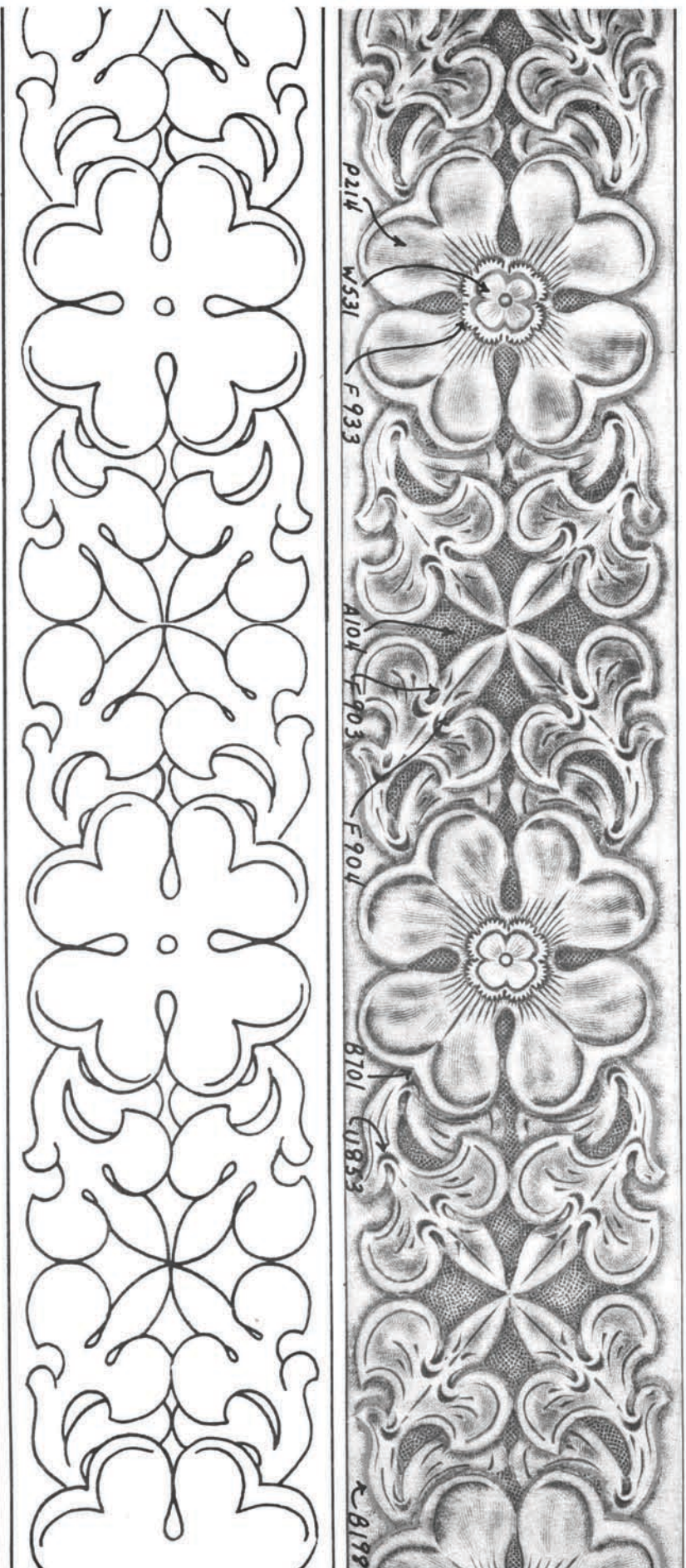

belt design by gene noland

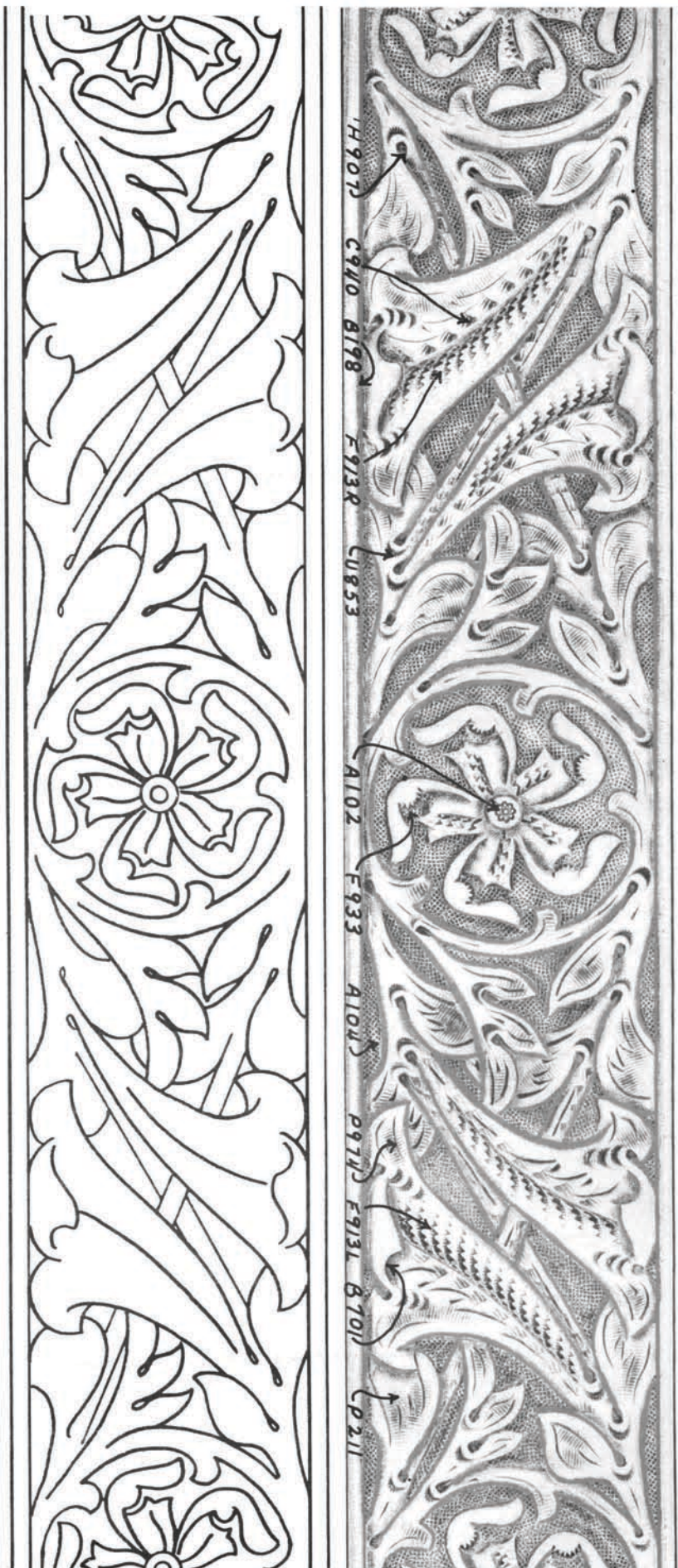

belt design by gene noland



belt design by gene noland

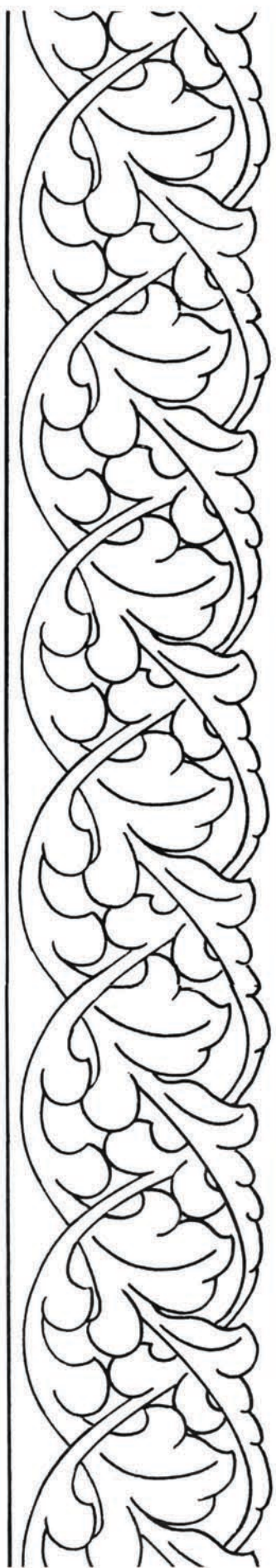

belt design by gene noland

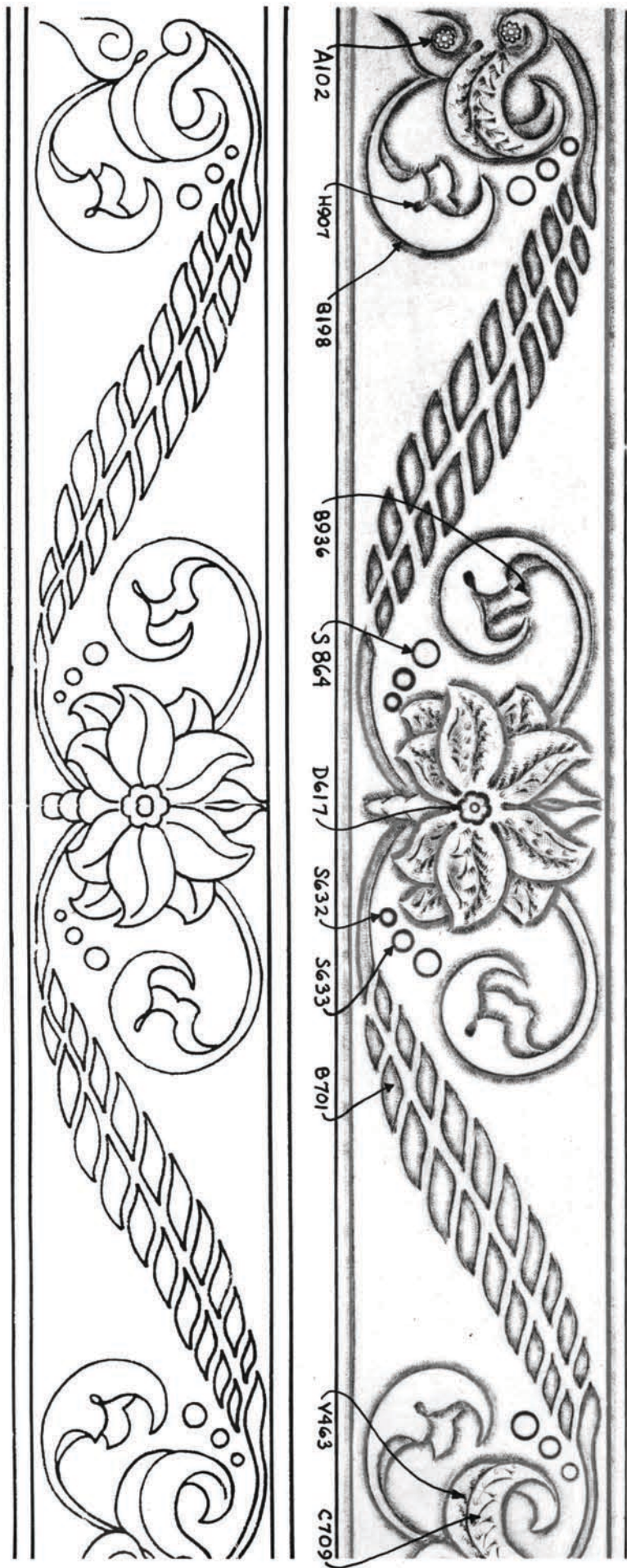

belt design by gene noland

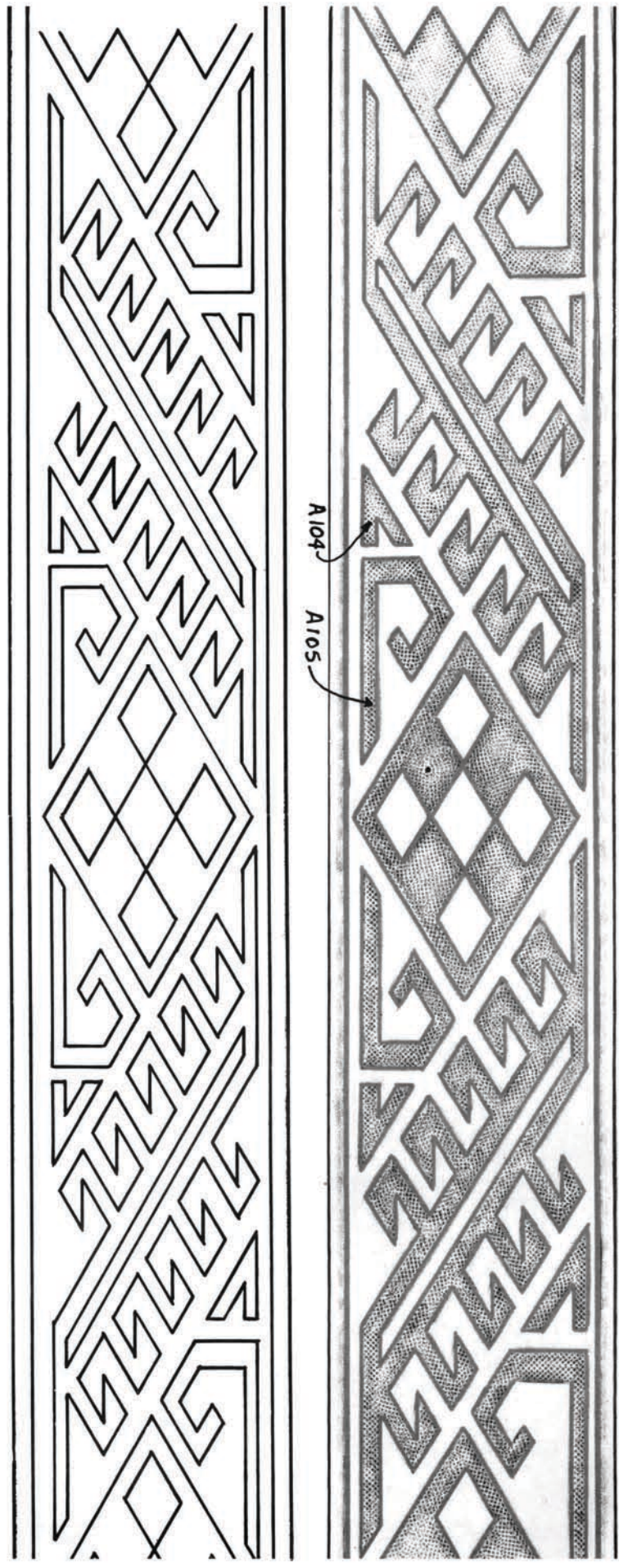

belt design by gene noland

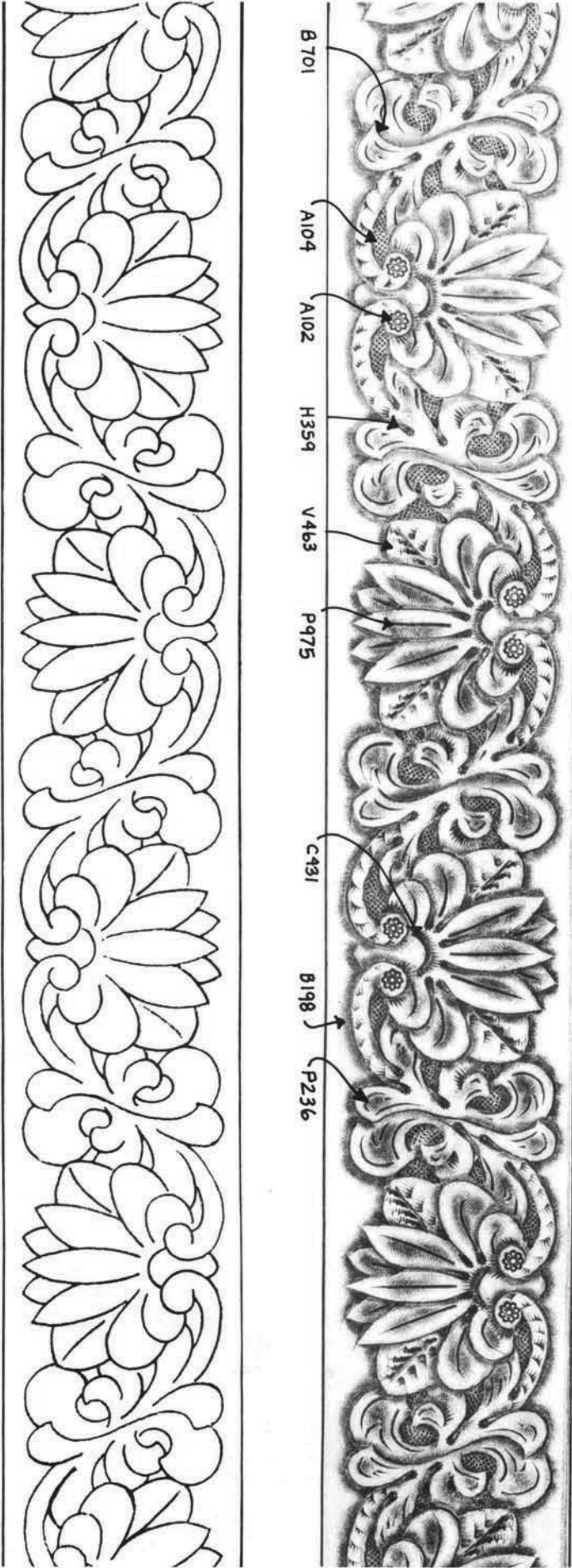

belt design by gene noland

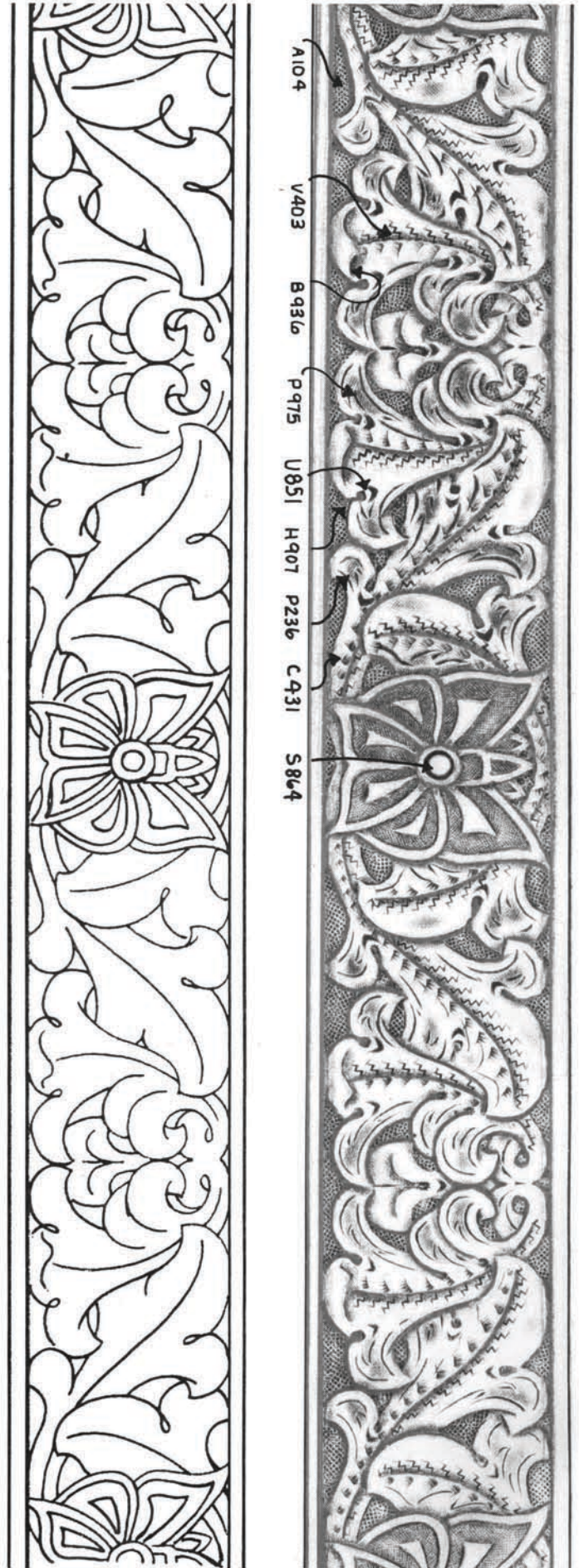

belt design by gene noland

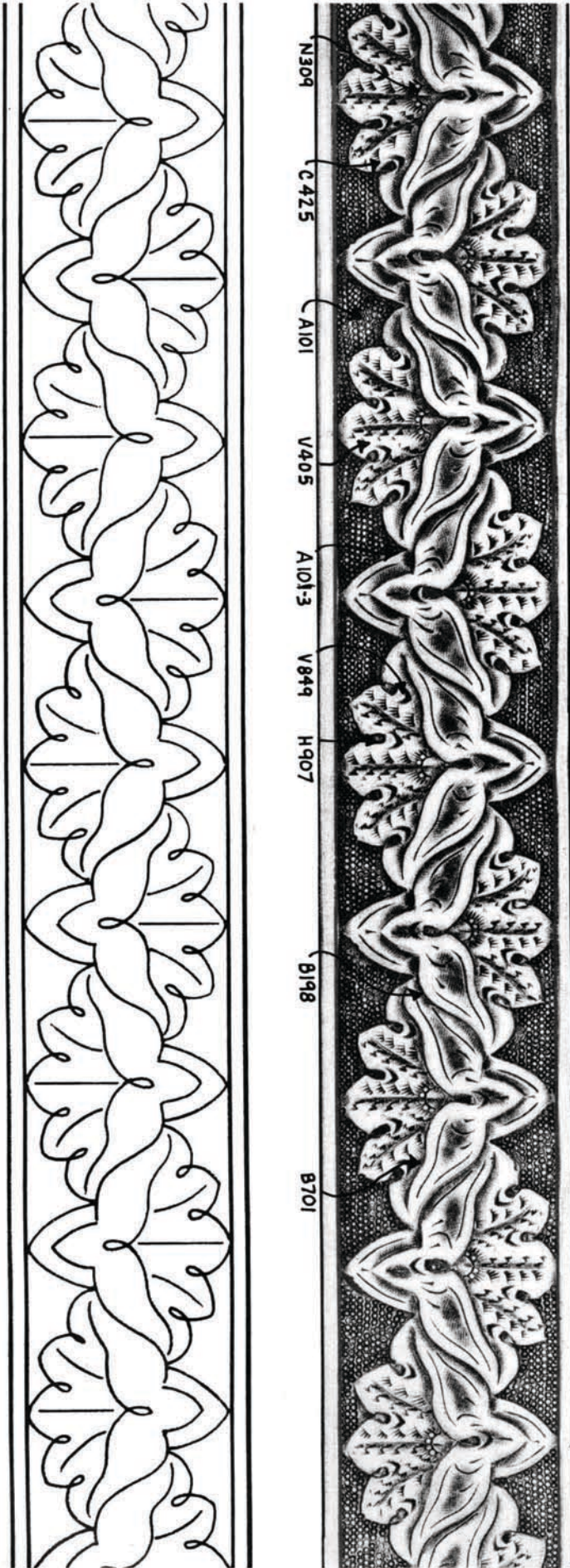

belt design by gene noland

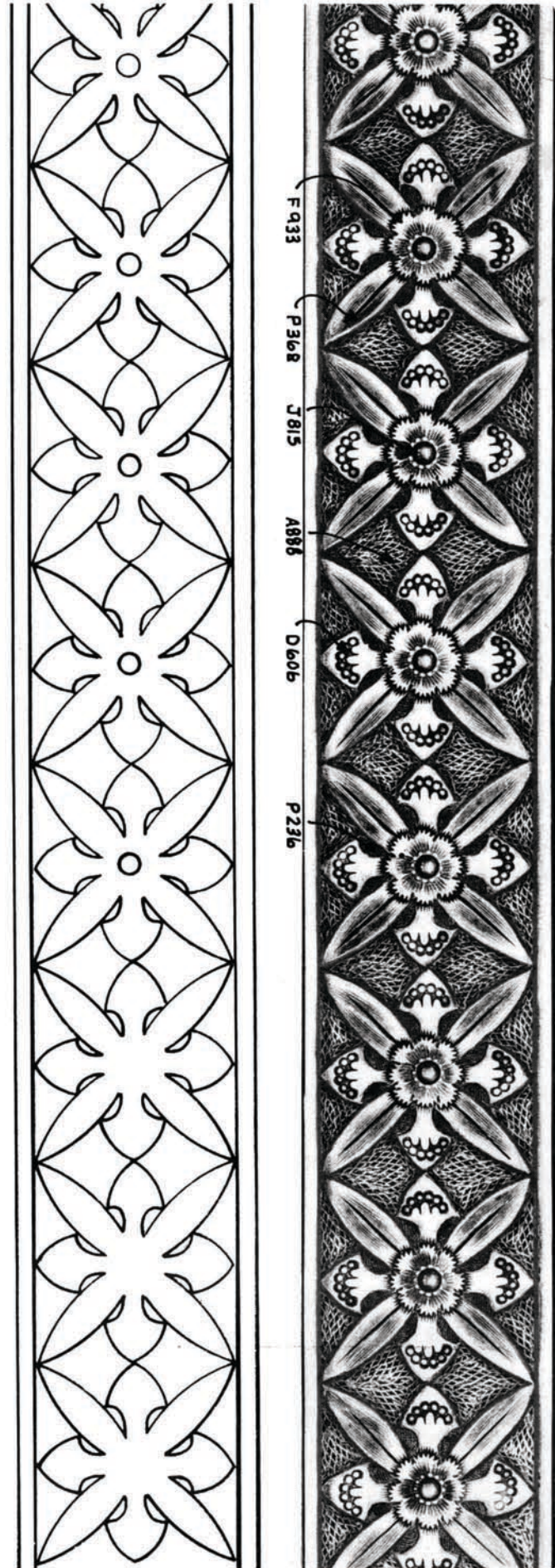

belt design by
dick bloomquist

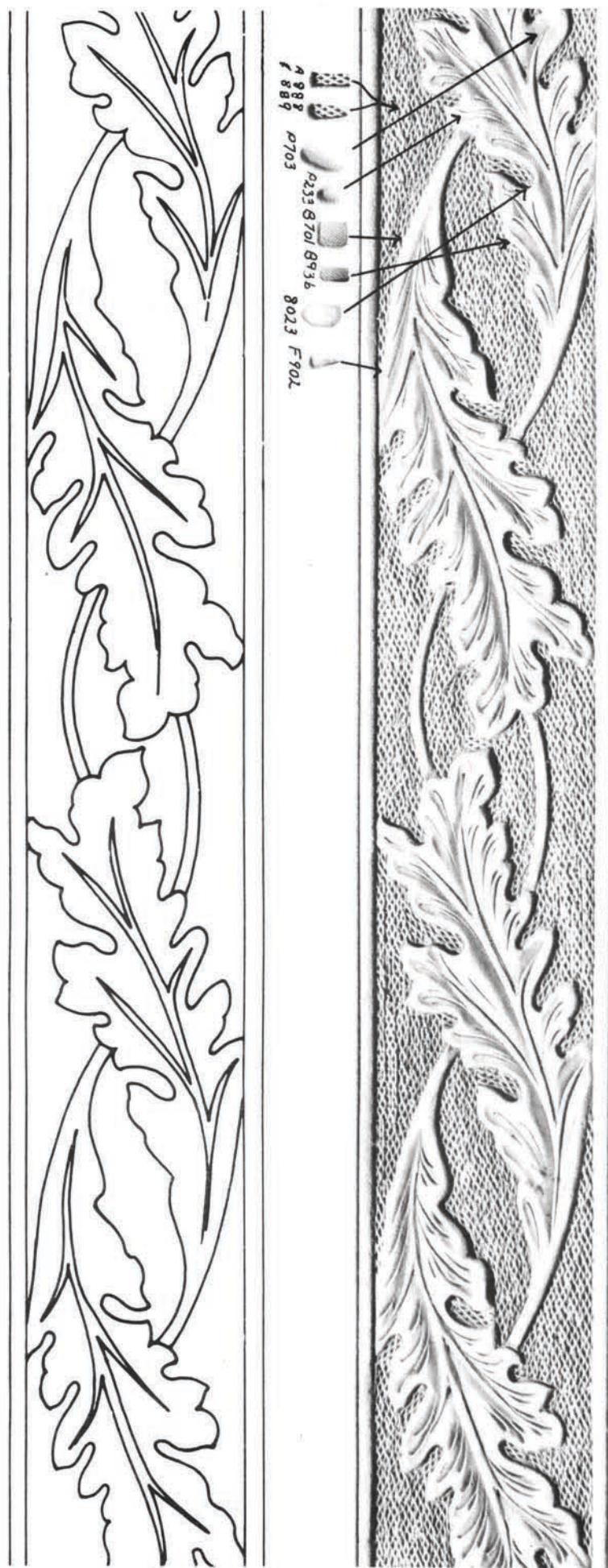

belt design by
dick bloomquist



belt design by
dick bloomquist

← CONTINUATION OF PATTERN. ALL DOTTED LINES OF DESIGN ON LEATHER, BUT DO NOT CUT.

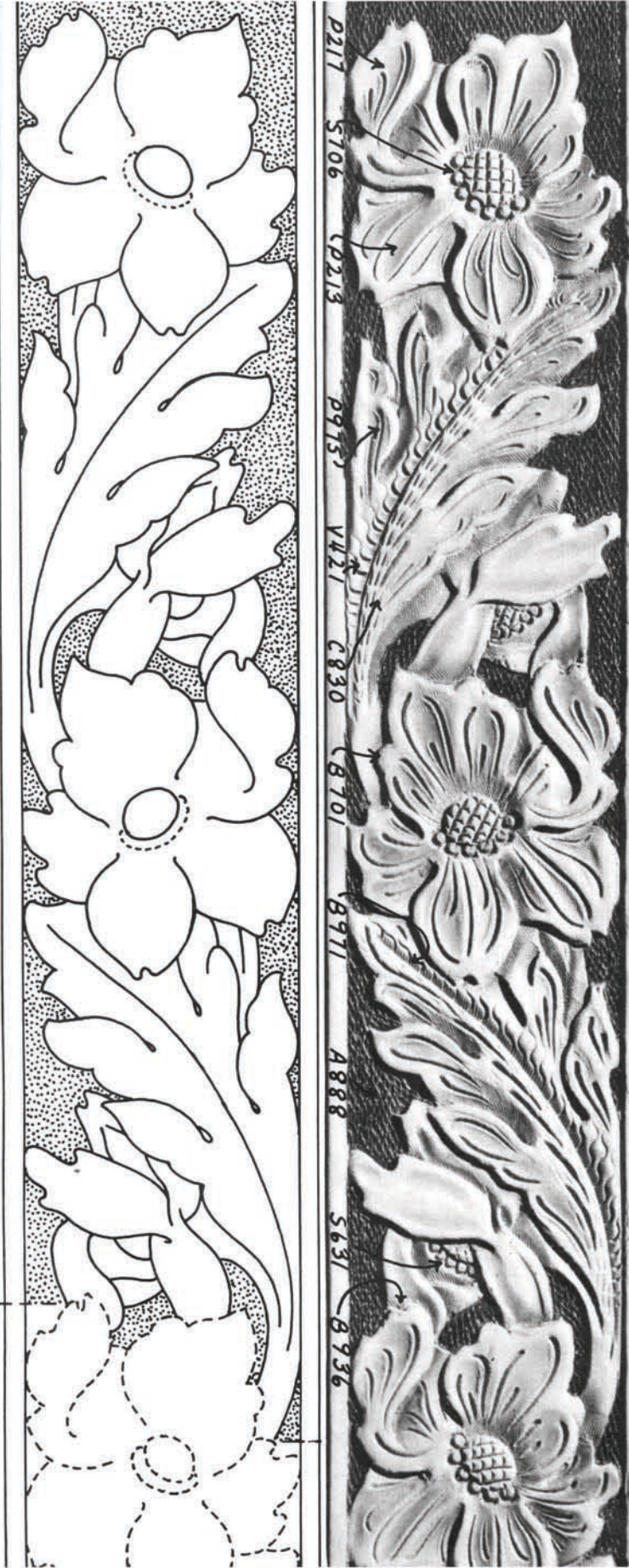

belt design by
dick bloomquist



mystery belts

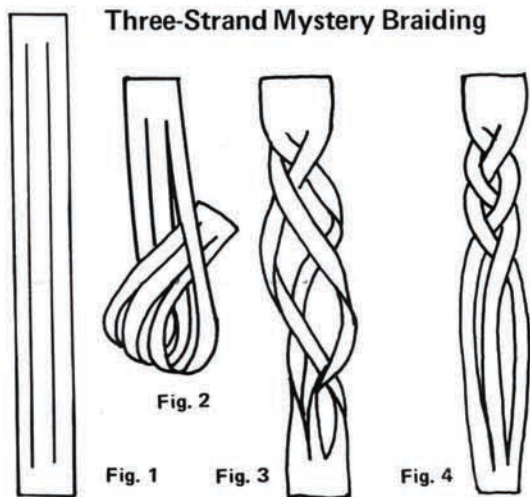
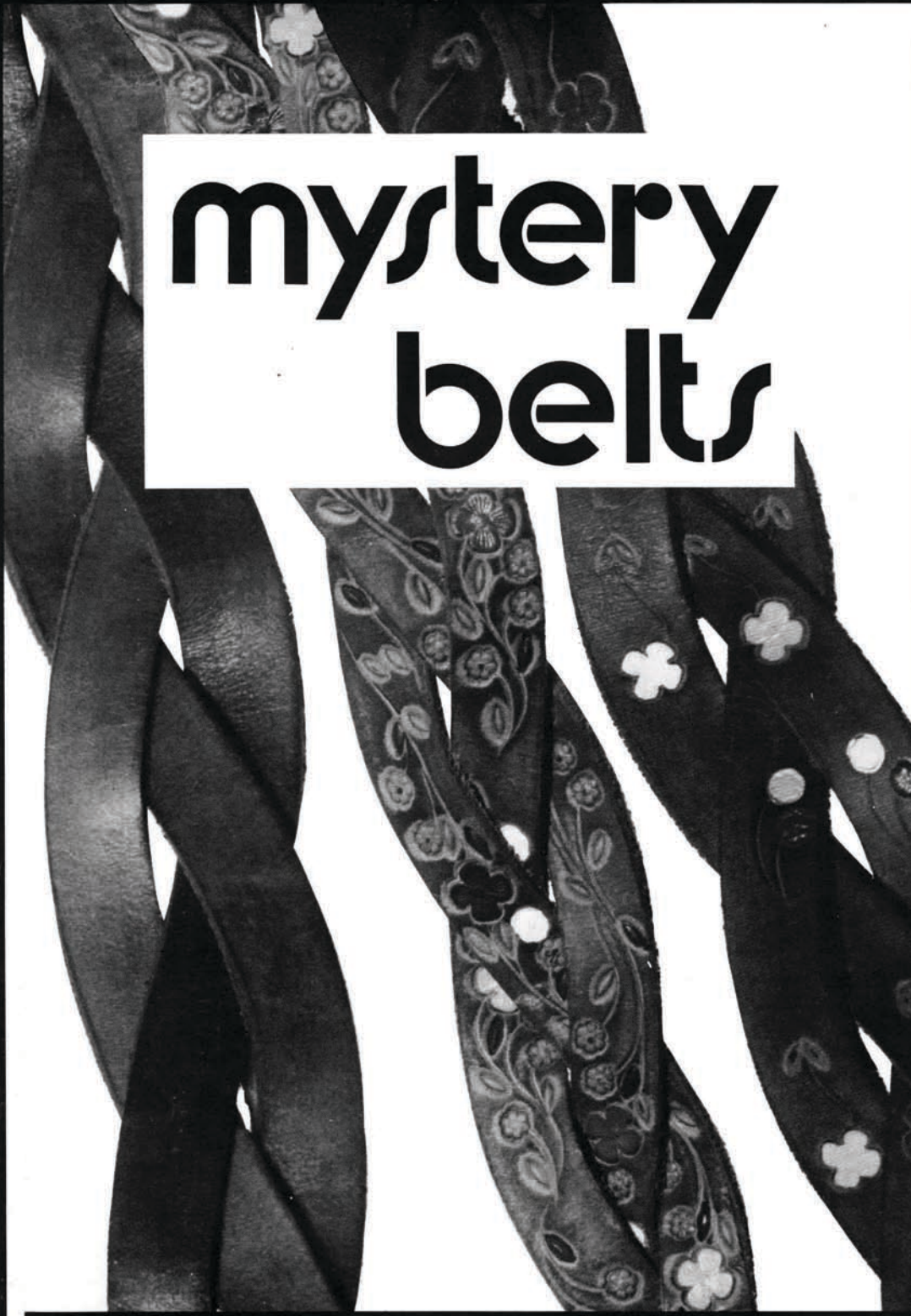
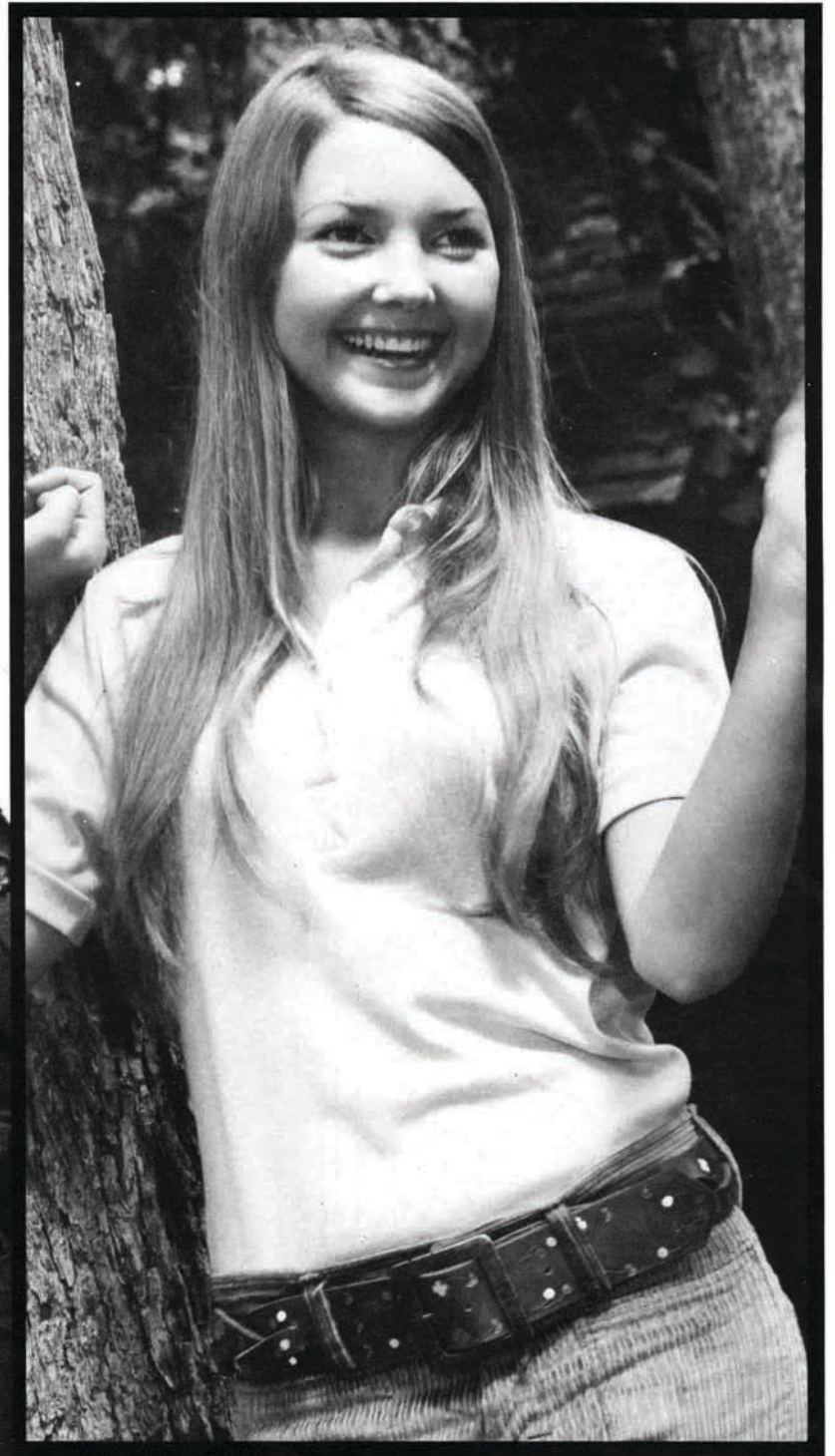

Step 1: Make two cuts in leather strip, dividing it into 3 equal parts joined at both ends. Edge and burnish each strip if you wish, (Fig. 1)

Step 2: Pass the lower end of strip through the slit between strands 2 and 3. (Fig. 2)

Step 3: With resulting braid kept at the bottom, go to the top end and pass strands 1 over 2, 3 over 1 and 2 over 3. Now pass the lower end of strip between strands 2 and 3. (Fig. 3)

Step 4: Again pass strands 1 over 2, 3 over 1 and 2 over 3. Braiding cycle is now complete, appearing as in Fig. 4. To continue braiding, follow steps 2, 3 and 4 until strands are not long enough to complete another full cycle (steps 2, 3 and 4). Equalize and smooth braid.

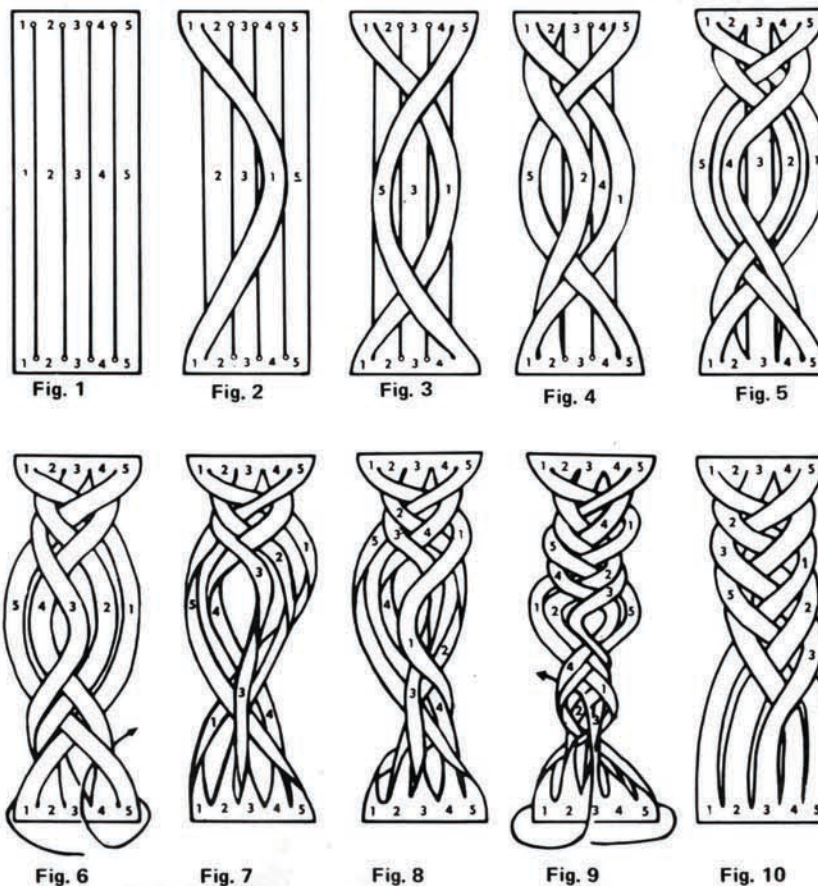

Five-Strand Mystery Braiding

Step 1: Make 4 cuts into strap, dividing it into 5 equal parts as in first illustration.

Step 2: Bring strip 1 to the right over strips 2 and 3 as in second illustration. Now bring strip 5 over strips 4 and 1. (Fig. 3)

Step 3: Take strip 2 and bring over strips 5 and 3 (Fig. 4) and pass strip 4 from right to left over strips 1 and 2 (Fig. 5)

Step 4: In Fig. 6 two steps are shown. First bring strip 3 around and over strips 5 and 4. The upper portion of this strap must be held intact. Next, take the bottom of the strap and pass through the opening between strips 3 and 4.

Step 5: Now the braid should look like Fig. 7. Pay no attention to the tangled strips at the bottom and continue to work at the top.

Step 6: Take strip 1 and bring over strips 2 and 3 (as shown in Fig. 8). Repeat this operation from each side four more times. Then you will take the bottom of the strap through strips 3 and 4 as shown in Fig. 9. The lower part of the braid will then straighten itself out (Fig. 10). When you reach this point begin all over again. Pass strip 1 over 2 and 3 as in Fig. 1. When the point corresponding to that in Fig. 6 is reached, turn in the bottom as before, then continue as in Fig. 7 until the end.

Step 7: Tighten up the braid at the top so it will be easier to work at the bottom. When the braid is completed loosen it until it is even throughout.



