

Vintage Pattern Series



The advertisement features a large, ornate leather bowling bag with two handles and a smaller, similarly styled bag below it. A circular inset shows the bag in its carrying case. The background is a light brown color with a decorative border at the top. The text is in a classic serif font, with the brand name 'Tandy' in a stylized script.

Tandy
LEATHER COMPANY

Top Quality, Genuine Cowhide
Bowling Bag Carries All Necessities!

League Leader

BOWLING BAG KIT

KIT CONTAINS: Pre-cut leather parts, welded steel frame, rubber ball rest, all necessary hardware, double action zipper, 5 metal feet, lacing, lacing needle, patterns and complete instructions.

Dist. By
TANDY WHSE. CO.
FORT WORTH, TEXAS

These digitized patterns do not include any kit parts they may mention.

Finished size approx. 14"x13"x8".



LeathercraftLibrary.com
DIGITAL MEDIA FOR LEATHERCRAFTERS



Kit Pattern Digital Download

This PDF file contains 1 (one) full Kit Pattern. The PDF has been put together to give you options when it comes to printing. Pages and patterns that have a side longer than 11 inches have been provided in two formats:

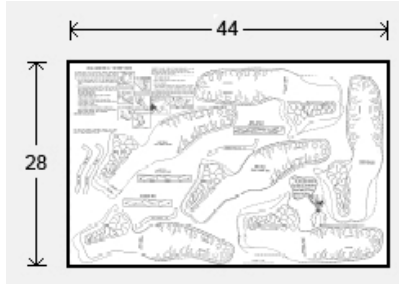

1) Full Size

If you would like to have a full size print out, take the full size pages to your local print shop and they can print it for you.

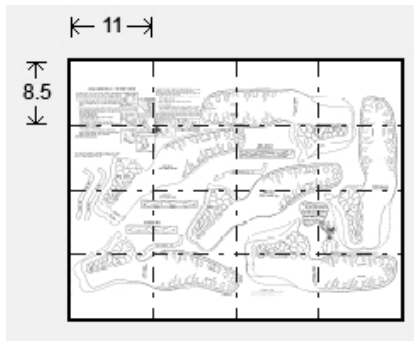

2) Tiled

The tiled pages give you the option of printing the larger patterns at home. You print the tiled pages and then assemble them to make the larger patterns.

These digitized patterns do not include any kit parts that they may mention.

Please note: When printing on a home printer, use the settings seen on the image to the right in the Page Handling area of the Adobe Reader print dialogue box. If your printer is cutting edges off, set "Page Scaling" to "Shrink to Printable Area". This will, however, decrease the size of the pattern a very small amount.

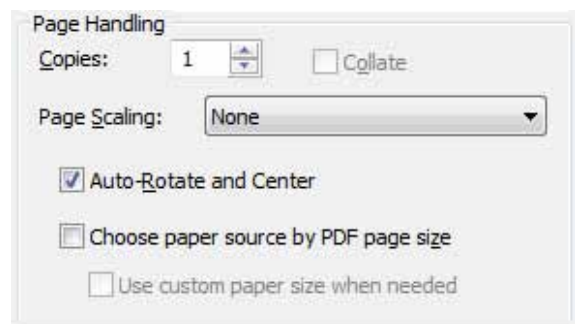

You may take this PDF file to your local print shop to have the full-size pages printed for your own personal use.

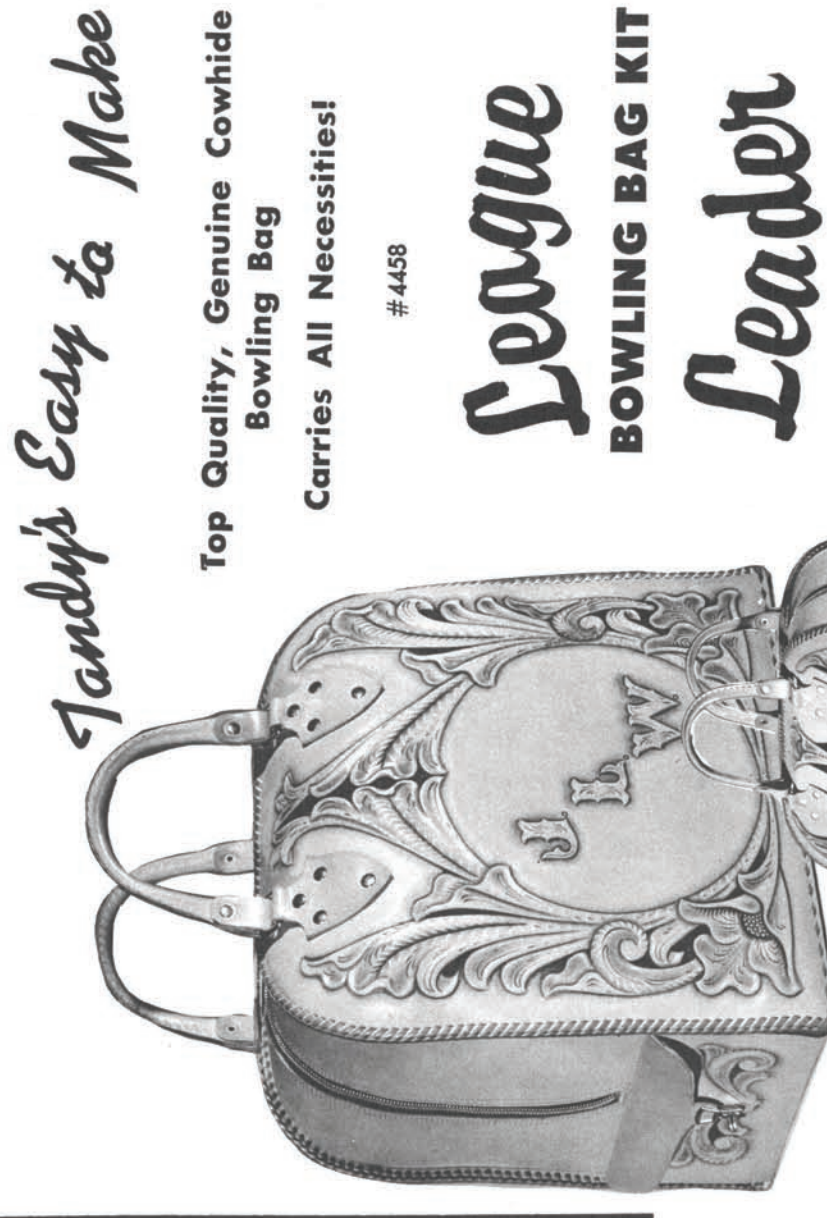

Tandy's Easy to Make
League Leader
BOWLING BAG KIT
 #4458
 KIT CONTAINS: Pre-cut leather parts, welded steel frame, rubber ball rest, all necessary hardware, double action zipper, 5 metal feet, patterns and complete instructions.

MADE BY
 Division of Tandy Corp.
 Fort Worth, Texas

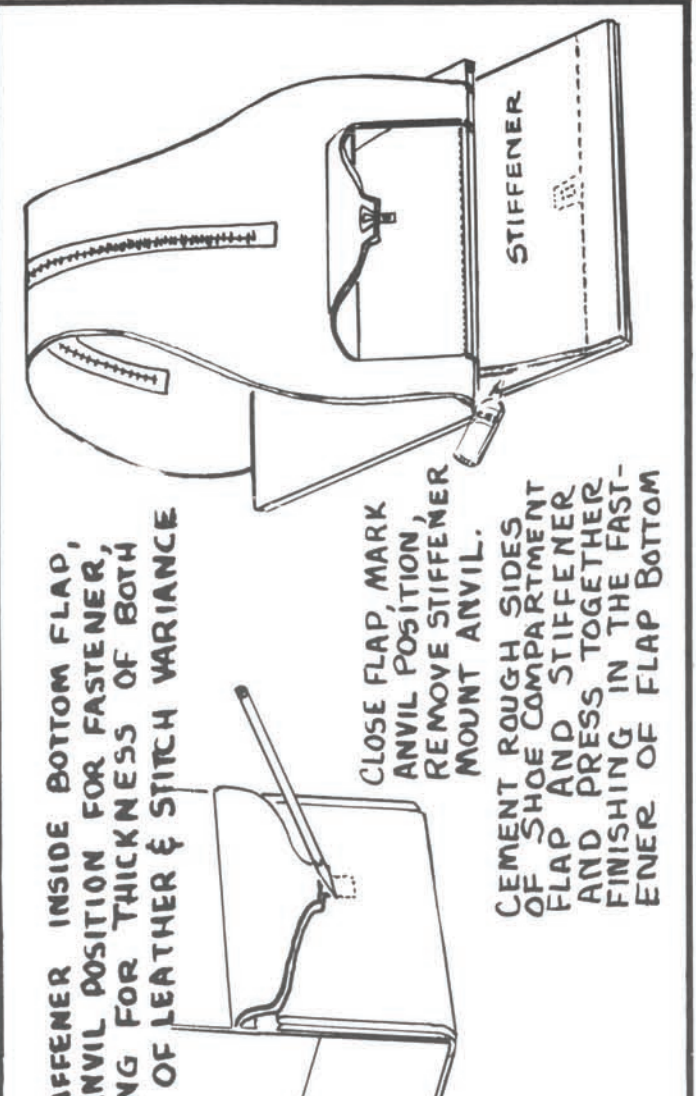

STEP 1:
 1. Place metal handle clips over brass ring in handle. Punch hole in leather using #5 round drive punch. (SEE ILLUSTRATION)
 2. Fold leather handle clip over metal handle clip. Rivet to bag back. Be sure to have smooth side of handle toward bag back.

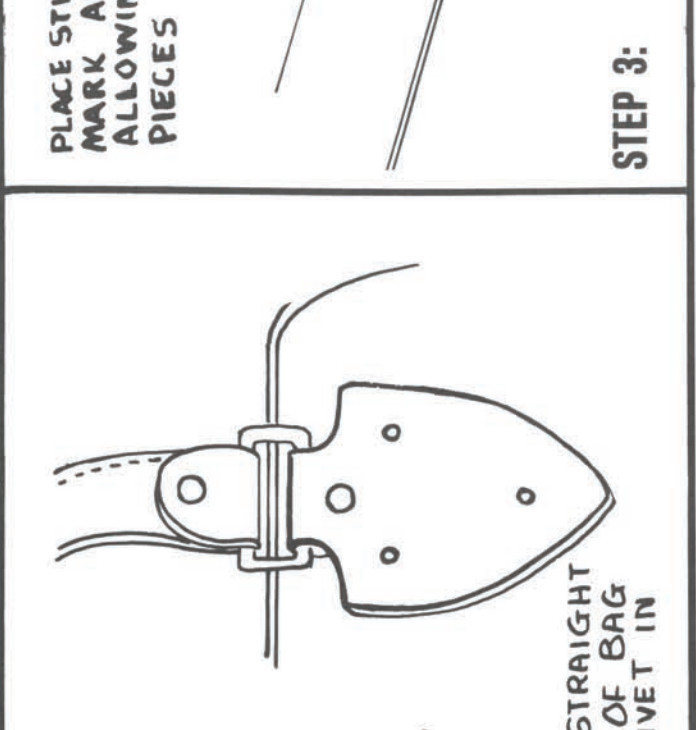

STEP 2:
 3. Now install anvils on shoe compartment. Anvils are attached to the back of the leather piece attached to bottom leather piece. (rough side to rough side)

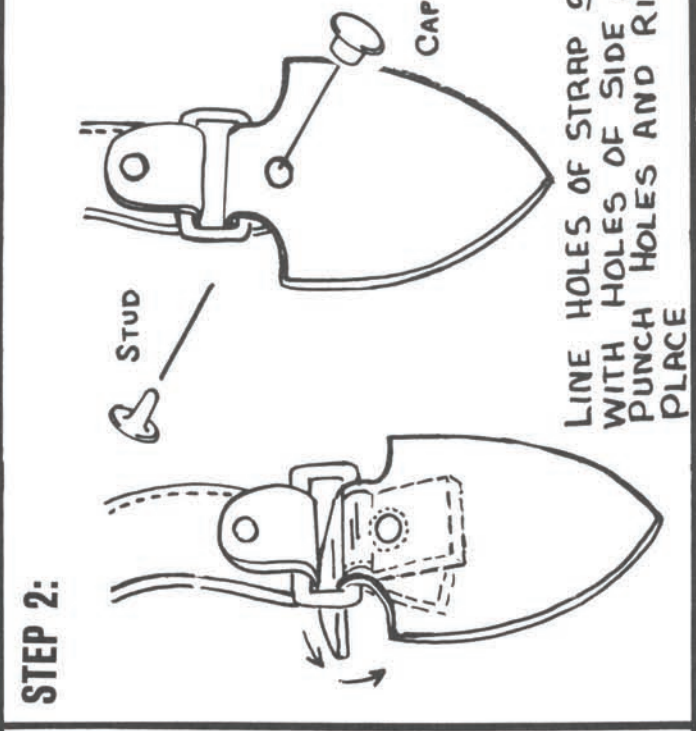

STEP 3:
 4. Fold leather handle clip over metal handle clip. Rivet to bag back. Be sure to have smooth side of handle toward bag back.

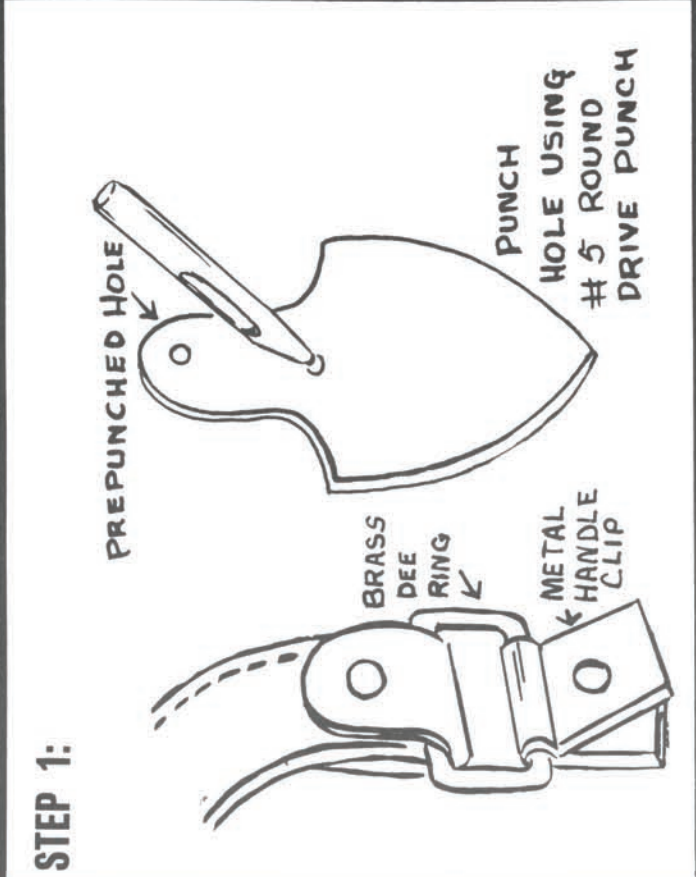

STEP 4:
 5. Using #13 Adjustable Gauge, gauge the bottom leather piece 1/2". (SEE ILLUSTRATION)
 6. Fold and hemstitch bottom edge of bag back. Overlap bag back 3/8" side edges of bottom leather piece. Cement them together, scribe a line 1/8" from Thonging Chisel. Now lace together using the Buckstitch.

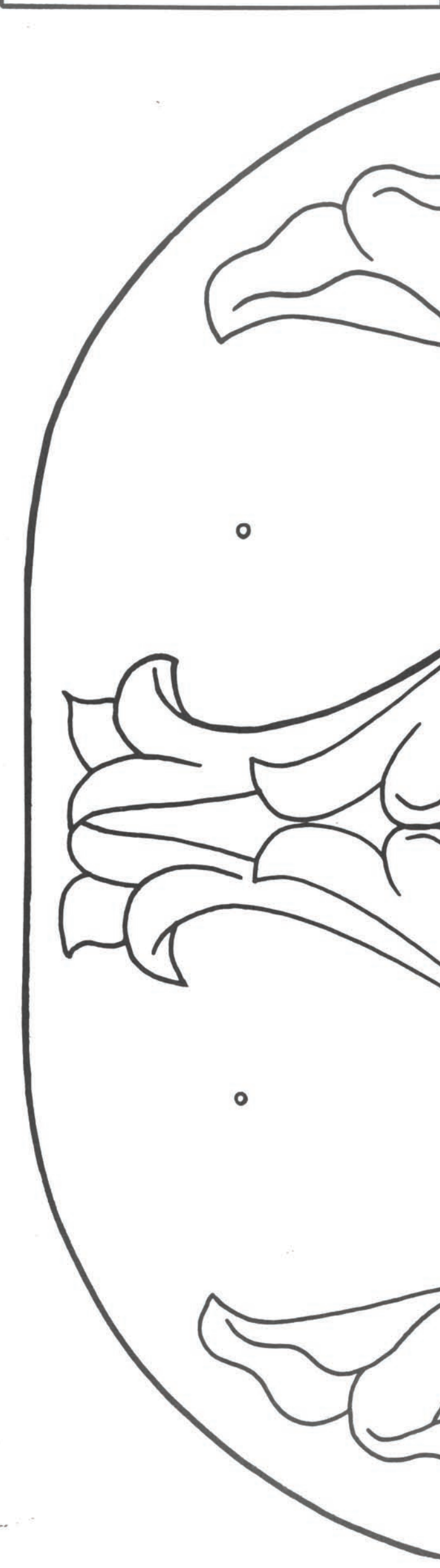

STEP 5:
 7. Stuff and cement edges of bag back and 3/8" gusset strip. Now cement gusset to bag back and hemstitch together. Trim them straight. If twisted pull loose and re-cement.

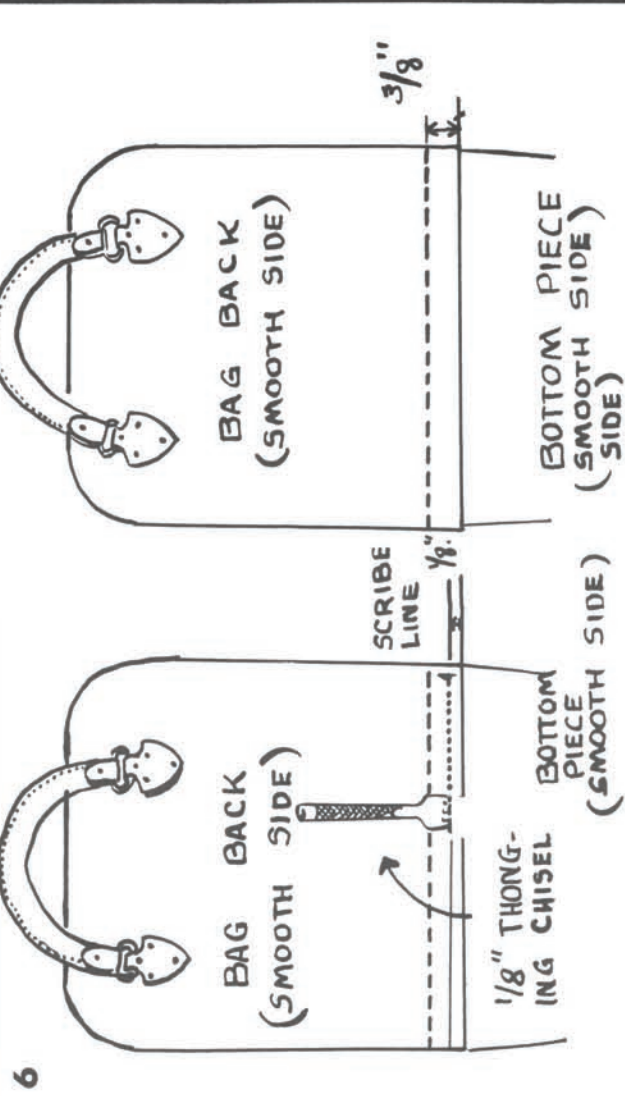

STEP 6:
 8. Now lace the gusset strips to the bag back. When using the Western Double Loop Stitch, go through the first and last hole twice.

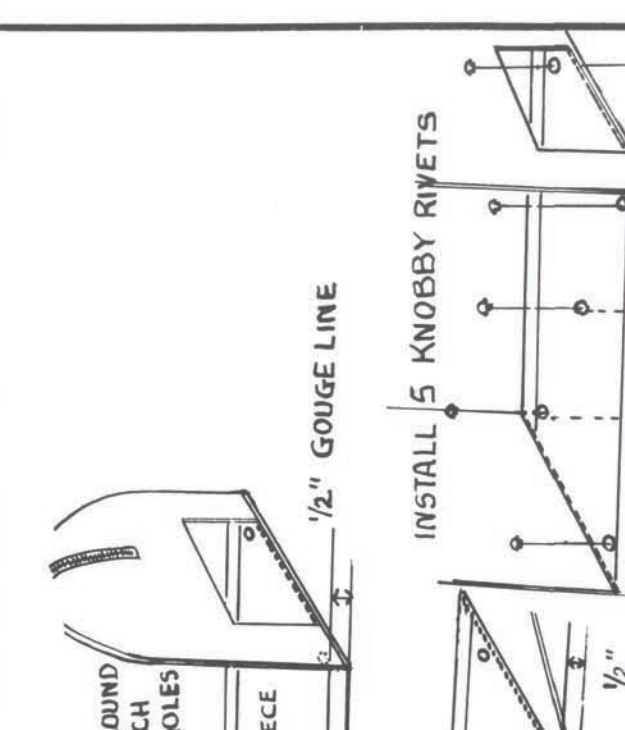

STEP 7:
 9. After you have laced the bag, you are ready to install the ball rest. Put rubber ball rest in place. (trim if necessary) and place protective ball rest in place.

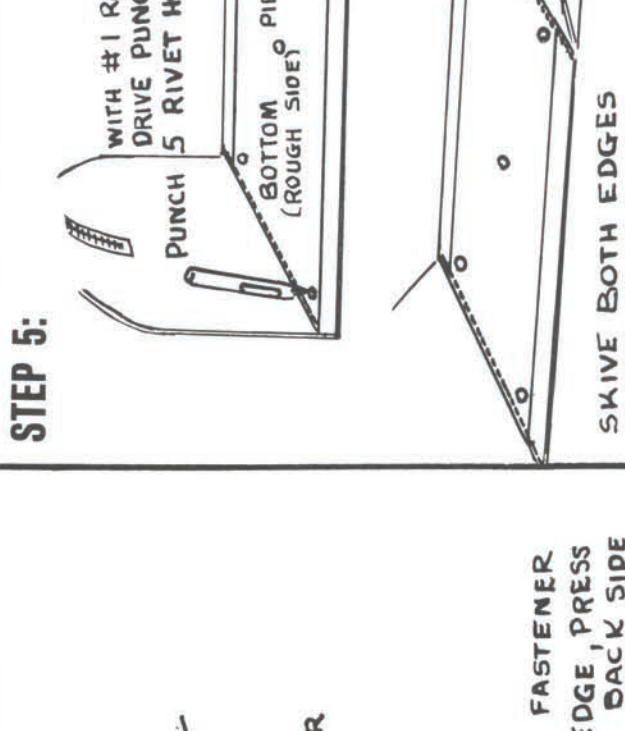

STEP 8:
 10. Cut a slit 1/4" long, 2" from each end of the leather strip. Push through hole in zipper catch. (smooth side up). Make a bleed knot. (SEE ILLUSTRATION)

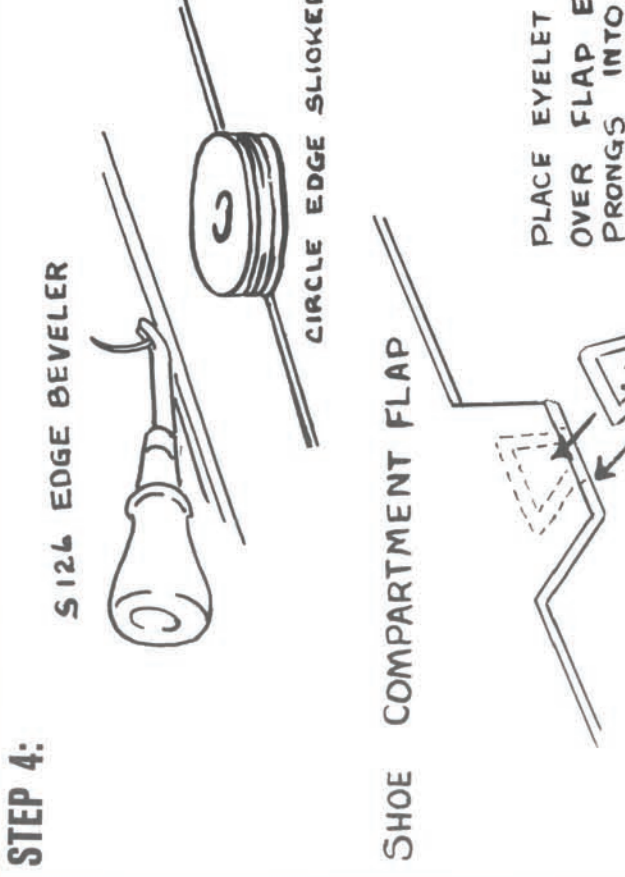

STEP 9:
 10. Cut a slit 1/4" long, 2" from each end of the leather strip. Push through hole in zipper catch. (smooth side up). Make a bleed knot. (SEE ILLUSTRATION)



STEP 10:
 11. Cut off ends of bag strip. Cement ends of bag strip to leather.

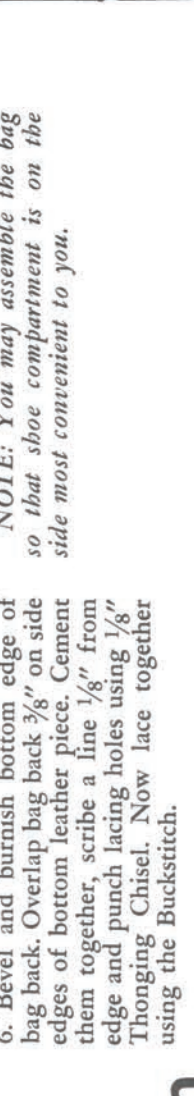

STEP 11:
 12. Complete the lacing.



STEP 12:
 13. Complete the lacing.



STEP 13:
 14. Complete the lacing.

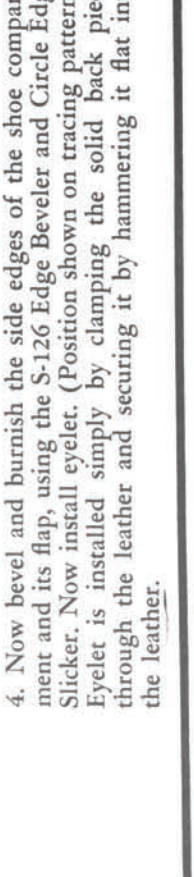

STEP 14:
 15. Complete the lacing.



STEP 15:
 16. Complete the lacing.



STEP 16:
 17. Complete the lacing.



STEP 17:
 18. Complete the lacing.



STEP 18:
 19. Complete the lacing.

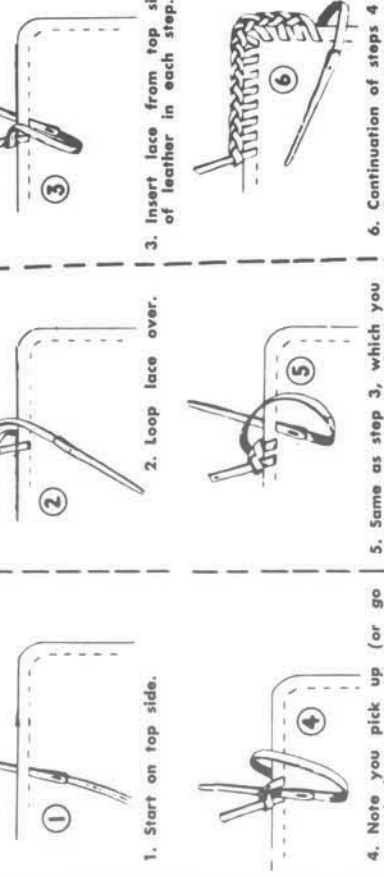

STEP 19:
 20. Complete the lacing.

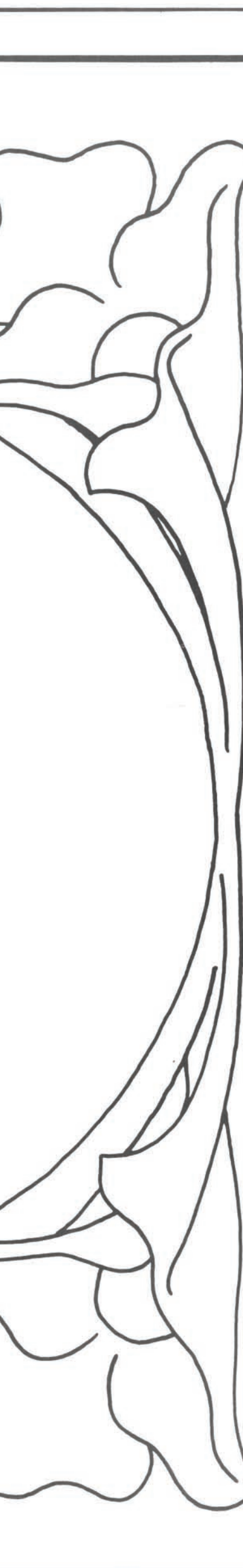

STEP 20:
 21. Complete the lacing.



STEP 21:
 22. Complete the lacing.



STEP 22:
 23. Complete the lacing.



STEP 23:
 24. Complete the lacing.



STEP 24:
 25. Complete the lacing.



STEP 25:
 26. Complete the lacing.



STEP 26:
 27. Complete the lacing.



STEP 27:
 28. Complete the lacing.

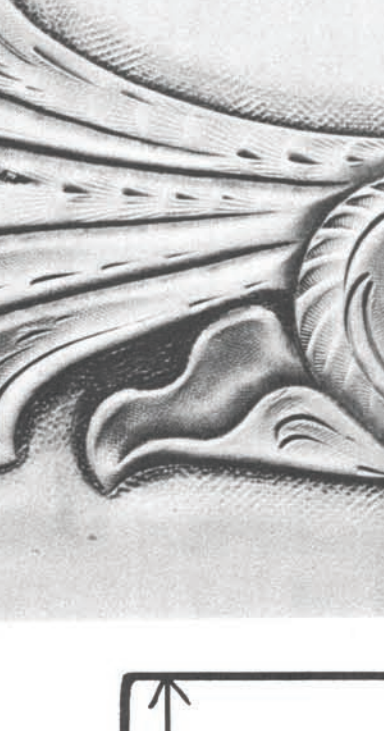

STEP 28:
 29. Complete the lacing.

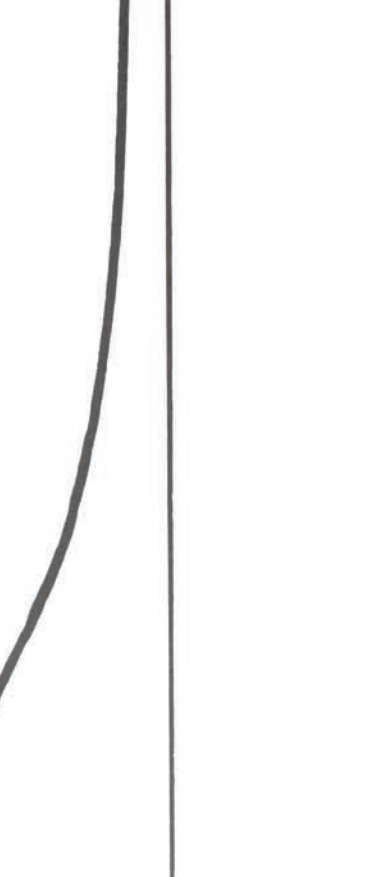

STEP 29:
 30. Complete the lacing.

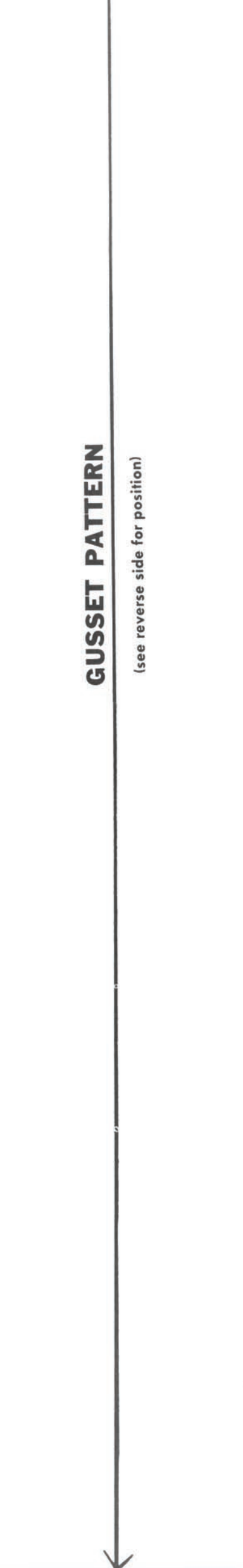

STEP 30:
 31. Complete the lacing.



STEP 31:
 32. Complete the lacing.



STEP 32:
 33. Complete the lacing.



STEP 33:
 34. Complete the lacing.



STEP 34:
 35. Complete the lacing.



STEP 35:
 36. Complete the lacing.



(No part of this or any other page may be re-printed without written permission.)
 PRINTED IN U.S.A.

Tandy's Easy to Make

**Top Quality, Genuine Cowhide
Bowling Bag**

Carries All Necessities!

#4458

League Leader

BOWLING BAG KIT

KIT CONTAINS: Pre-cut leather parts, welded steel frame, rubber ball rest, all necessary hardware, double action zip-per, 5 metal feet, patterns and complete instructions.

7. Skuff and cement edges of bag
back and 3/16" sheet steel



BY
HSE. CO.
Andy Corp.
h, Texas

DATA and 78 Gusset strip.
 Now cement gussets to bag back being very careful to cement them straight. If twisted pull loose and re-cement.

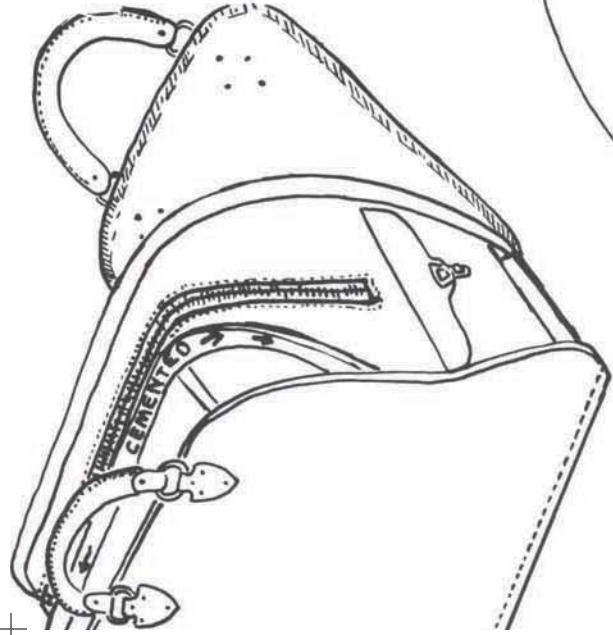

SCRIBE A LINE COMPLETELY AROUND GUSSET

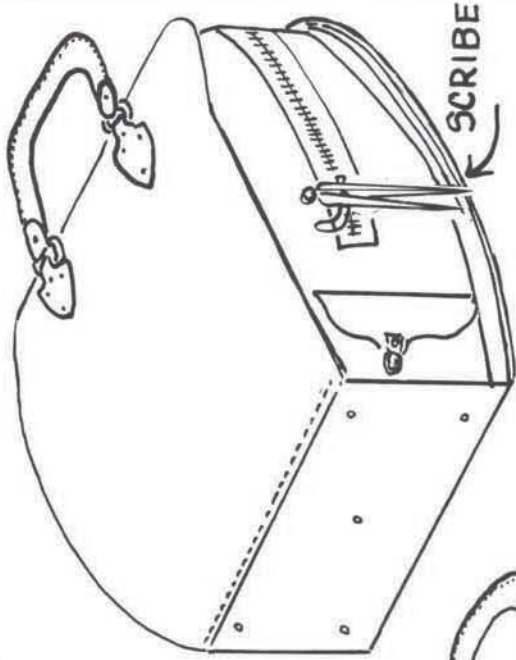

a line $\frac{1}{8}$ " from side edges set strip edge.
 the $\frac{1}{8}$ " Thonging Chisel, lacing holes completely d gussets.

ILLUSTRATION)

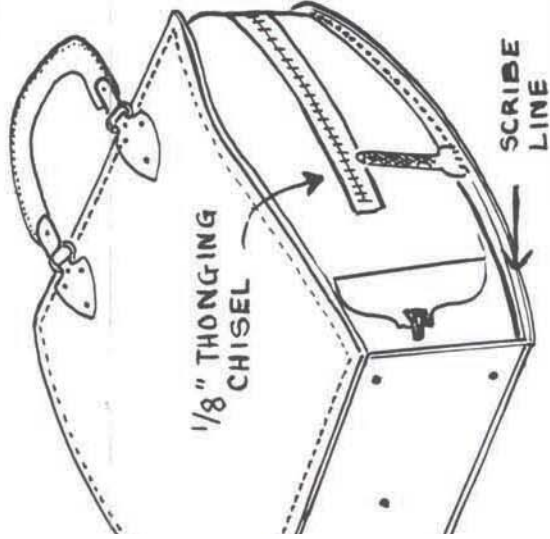

PUNCH LACING HOLES WITH $\frac{1}{8}$ " THONGING CHISEL ON LINE MARKED BY SCRIBE

8. Now lace the gusset strips to the bag back. When using the Western Double Loop Stitch, go through the first and last hole twice.

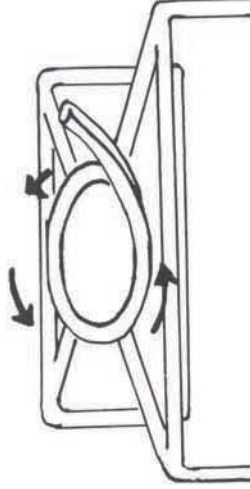
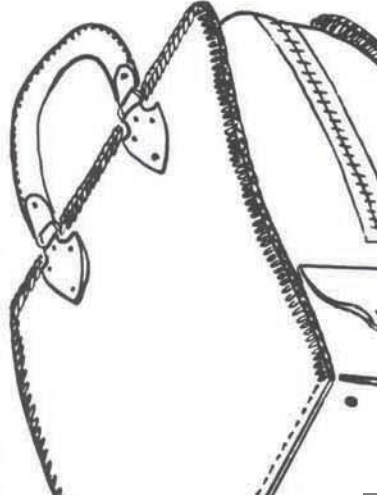

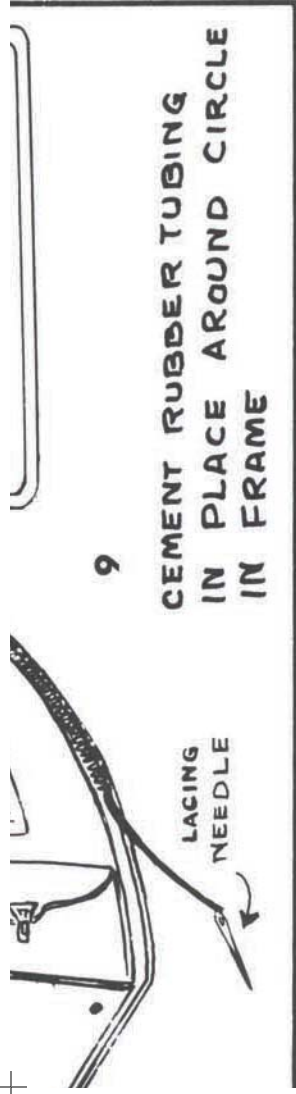

9

**CEMENT RUBBER TUBING
IN PLACE AROUND CIRCLE
IN FRAME**

9. After you have laced the bag, you are ready to install the ball rack. Put rubber protective tube around circle in frame. (trim if necessary) and place protective ball rack in place.

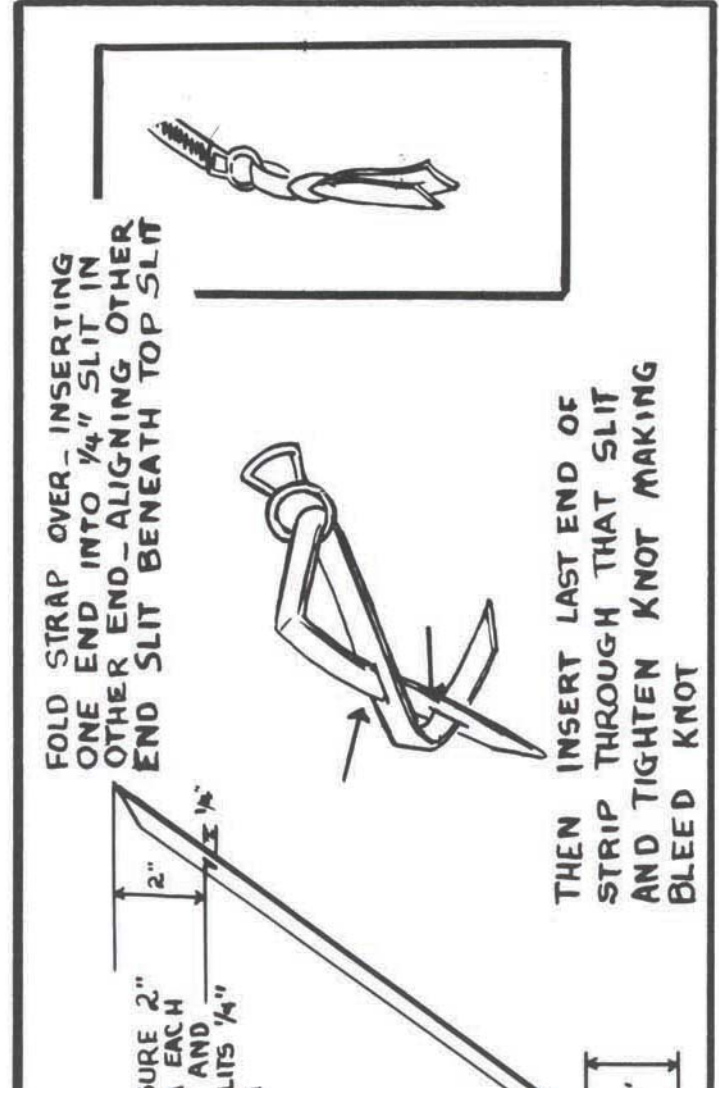

**FOLD STRAP OVER - INSERTING
ONE END INTO 1/4" SLIT IN
OTHER END - ALIGNING OTHER
END SLIT BENEATH TOP SLIT**

**THEN INSERT LAST END OF
STRIP THROUGH THAT SLIT
AND TIGHTEN KNOT MAKING
BLEED KNOT**

10. Cut a slit 1/4" long, 2" from each end of the leather strip. Place leather strip through hole in zipper catch. (smooth side up) Make a bleed knot. (SEE ILLUSTRATION)

PLACE STIFFENER INSIDE BOTTOM FLAP, MARK ANVIL POSITION FOR FASTENER, ALLOWING FOR THICKNESS OF BOTH PIECES OF LEATHER & STITCH VARIANCE

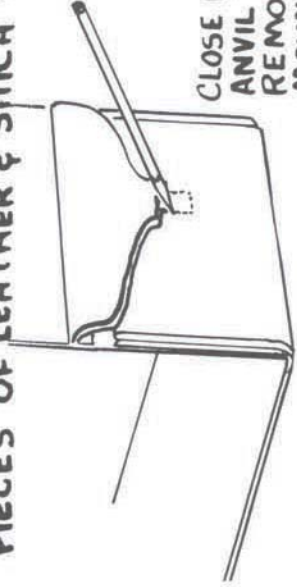

CLOSE FLAP, MARK ANVIL POSITION, REMOVE STIFFENER, MOUNT ANVIL.

CEMENT ROUGH SIDES OF SHOE COMPARTMENT FLAP AND STIFFENER AND PRESS TOGETHER FINISHING IN THE FASTENER OF FLAP BOTTOM

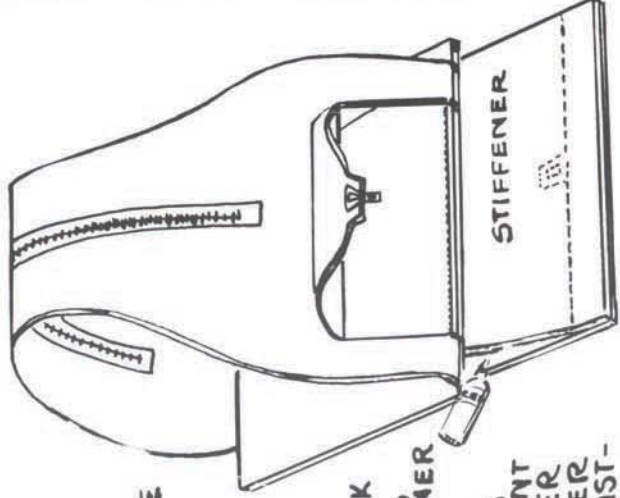

STEP 3:

- Now install anvil on shoe compartment. After anvil is in place, cement the leather piece to the back of the leather piece stitched to bottom leather piece. (rough side to rough side)

bag and punch position shown on completely through until both handles

6

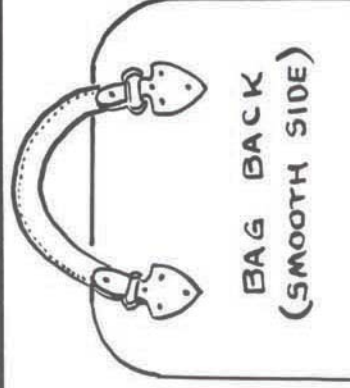
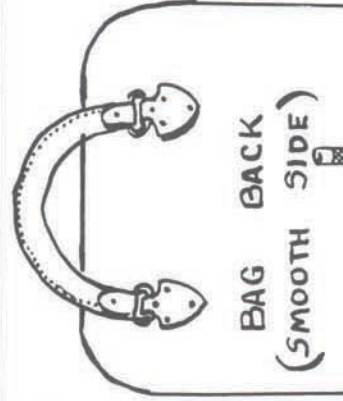

BBY RIVETS

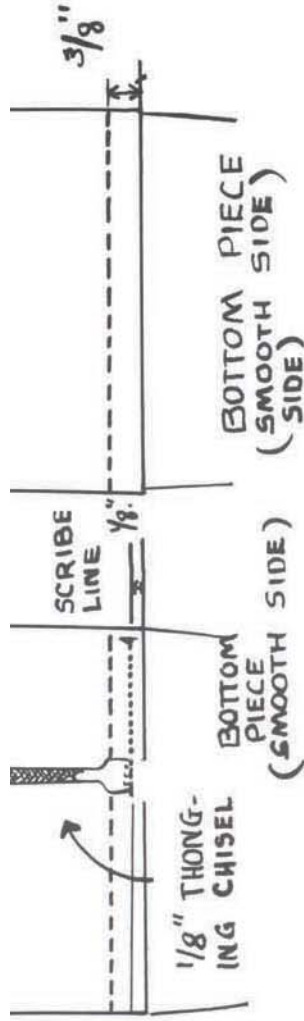
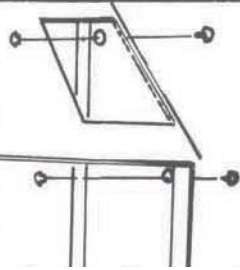

piece
anch,
ition

6. Bevel and burnish bottom edge of bag back. Overlap bag back $\frac{3}{8}$ " on side edges of bottom leather piece. Cement them together, scribe a line $\frac{1}{8}$ " from edge and punch lacing holes using $\frac{1}{8}$ " Thonging Chisel. Now lace together using the Buckstitch.

NOTE: You may assemble the bag so that shoe compartment is on the side most convenient to you.

Pattern

Scribe
of gus
Using
punch
around
(SEE

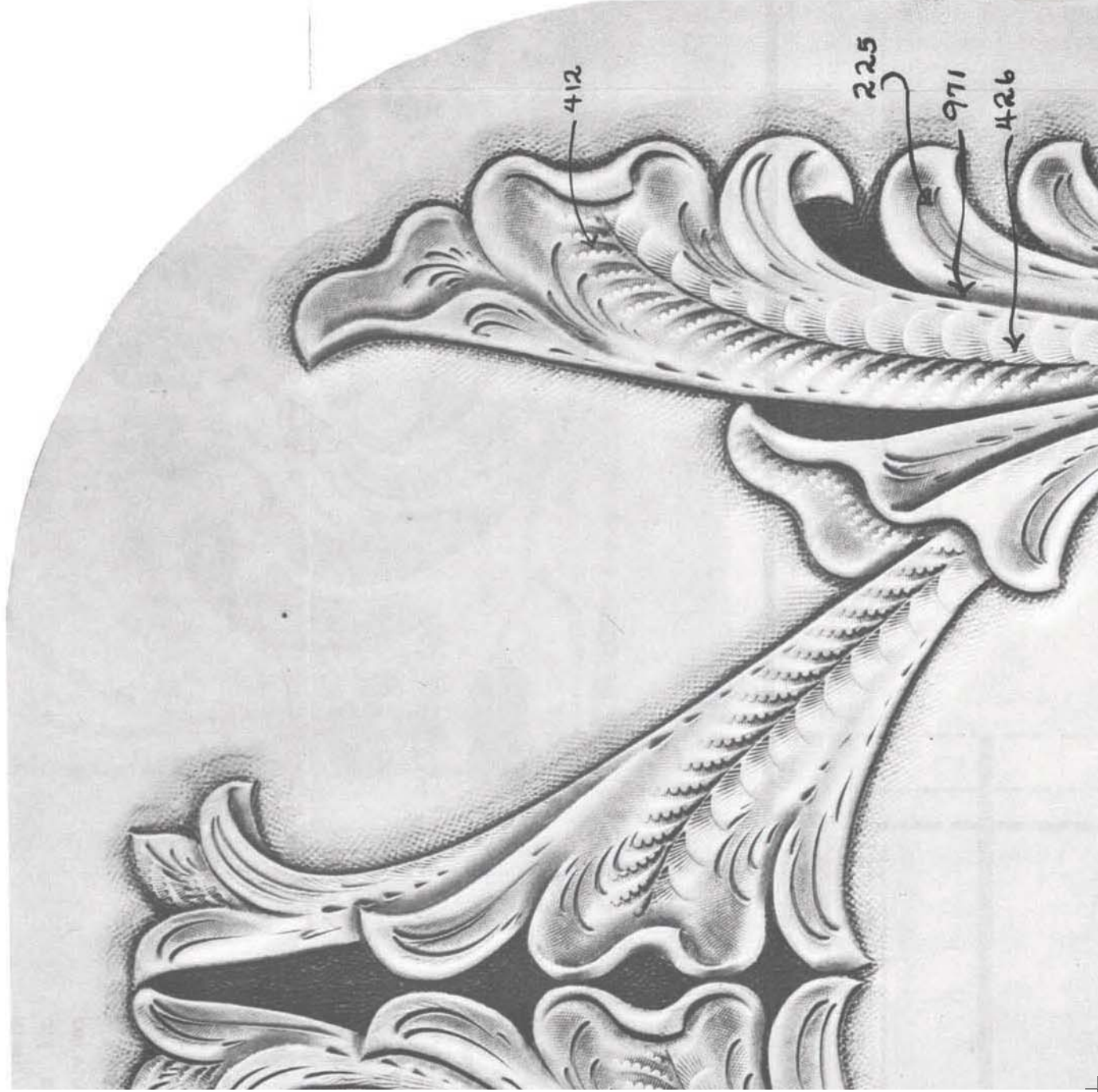
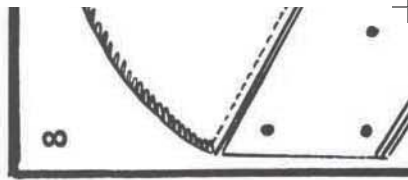
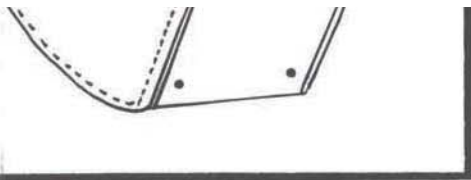

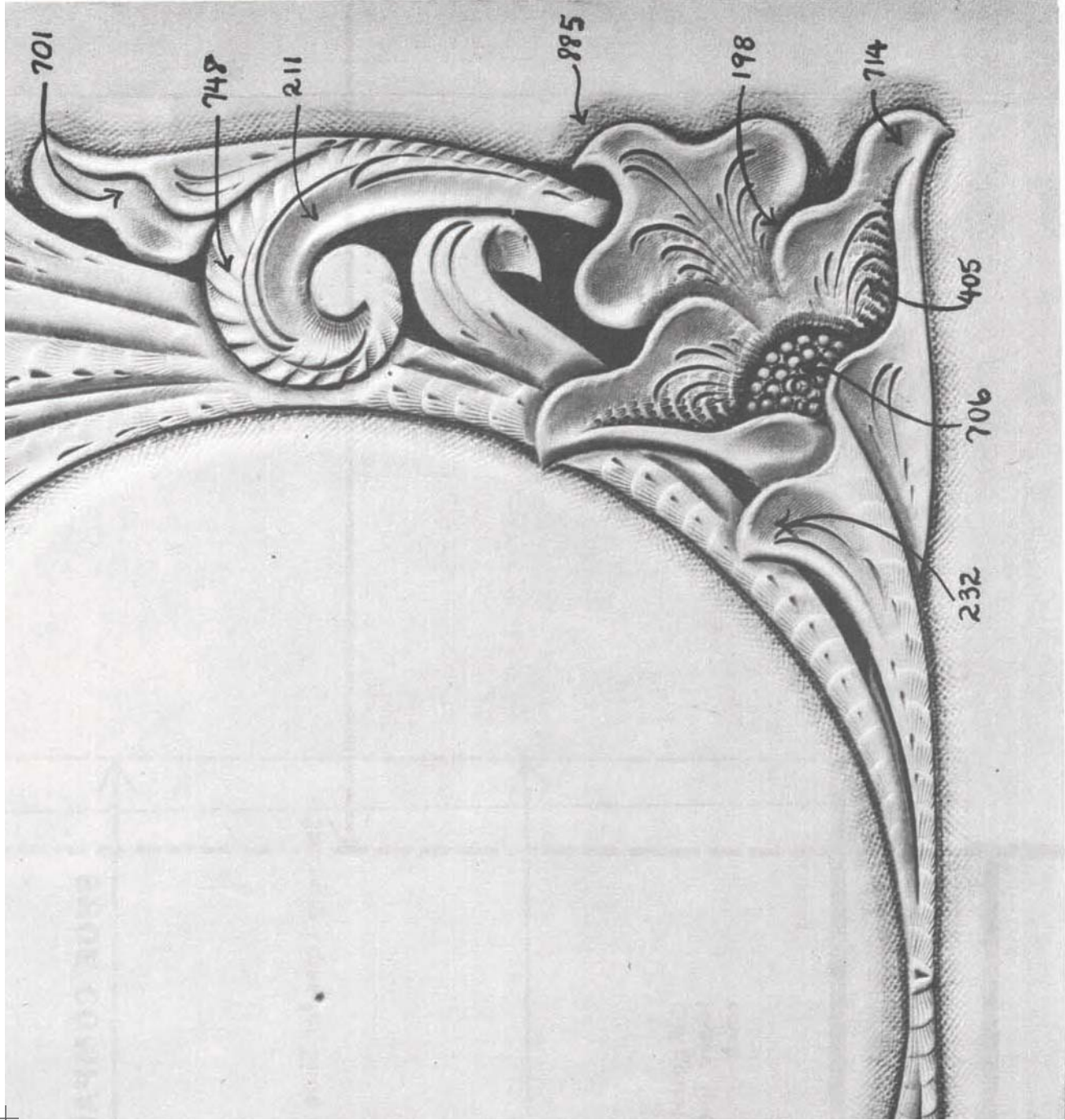

10

MEAS
FROM
END
CUT SI
LONG

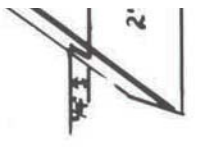



HEAD HOLE

PUNCH
HOLE USING
#5 ROUND
DRIVE PUNCH

STEP 2:

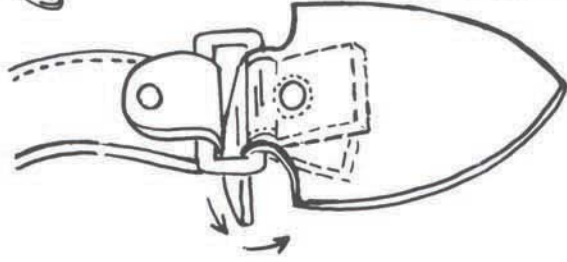

STUD

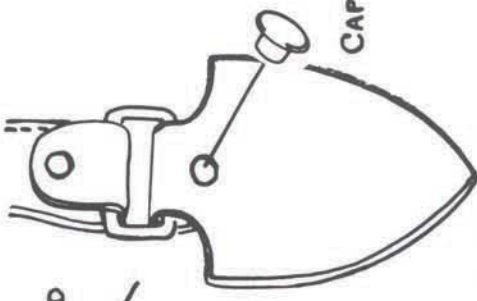

CAP

LINE HOLES OF STRAP STRAIGHT
WITH HOLES OF SIDE OF BAG
PUNCH HOLES AND RIVET IN
PLACE

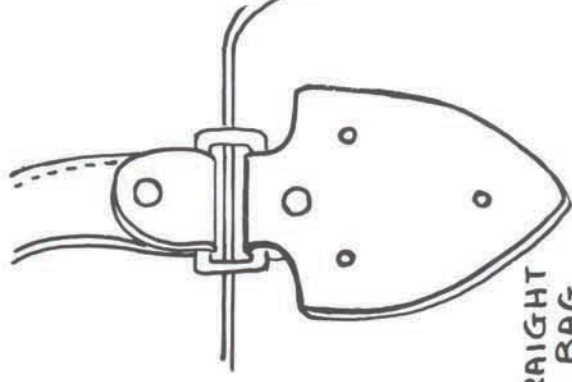

Press ring in handle. Punch head and is not needed to be indicated on tracing pattern.

(SEE ILLUSTRATION)

Line tab up straight on other three holes in tab. (Punch tracing pattern) Punch on bag back. Repeat same step 1 are in place.

BEVELER

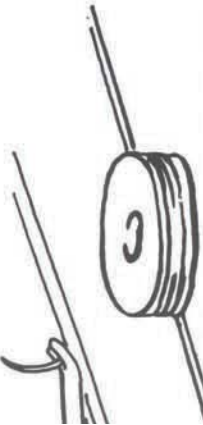

CIRCLE EDGE SLICKER

STEP 5:

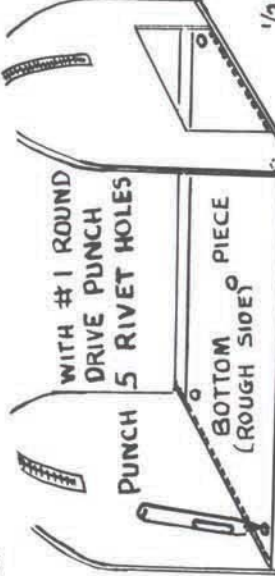

WITH #1 ROUND
DRIVE PUNCH
PUNCH 5 RIVET HOLES
BOTTOM SIDE OF
PIECE
(ROUGH SIDE)

1/2" GORGE 1 IN

LAP



PLACE EYELET FASTENER OVER FLAP EDGE, PRESS PRONGS INTO BACK SIDE OF FLAP SECURELY.

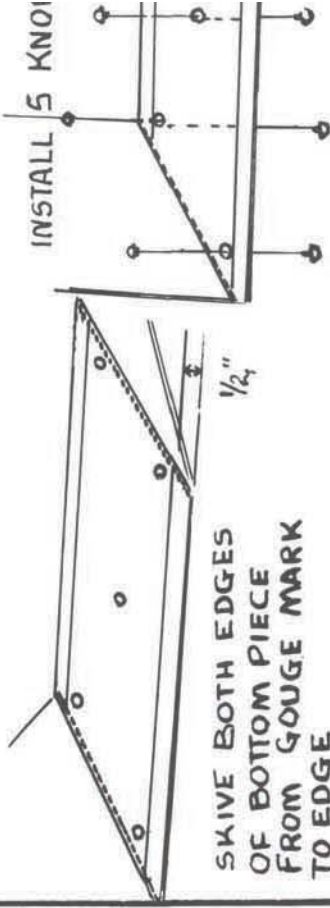

the side edges of the shoe compartment. Use the S-126 Edge Beveler and Circle Edge (Position shown on tracing pattern) by clamping the solid back piece securing it by hammering it flat into

5. Using #13 Adjustable Gouge, gouge the bottom leather 1/2" from side edges. Using the #1 Round Drive Punch holes in leather bottom piece for knobby rivets. (Position shown on tracing pattern) Install knobby rivets

O LACE

Double Loop



lace over.

3. Insert lace from top side of leather in each step.



5. which you finish.

6. Continuation of steps 4 and 5.



8

8. Only one hole remains unlaced.



9. Only one hole remains unlaced.



11

For smooth flat lacing edge, place project on table and top lace down with mallet.

11. is of lace close to edge (on inside). 12. is of lace to

Tooling pattern and instructions on other side.

Photocarve

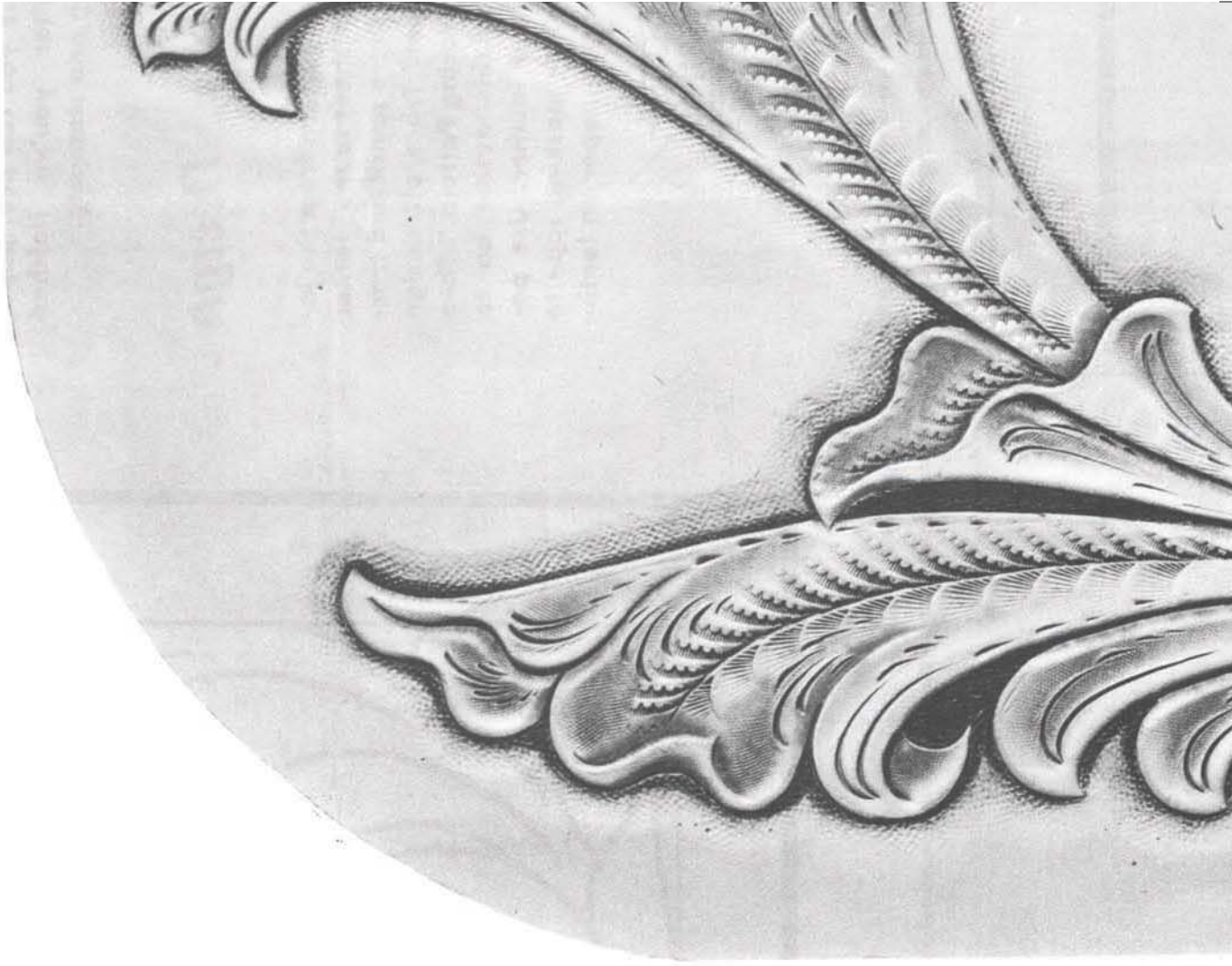

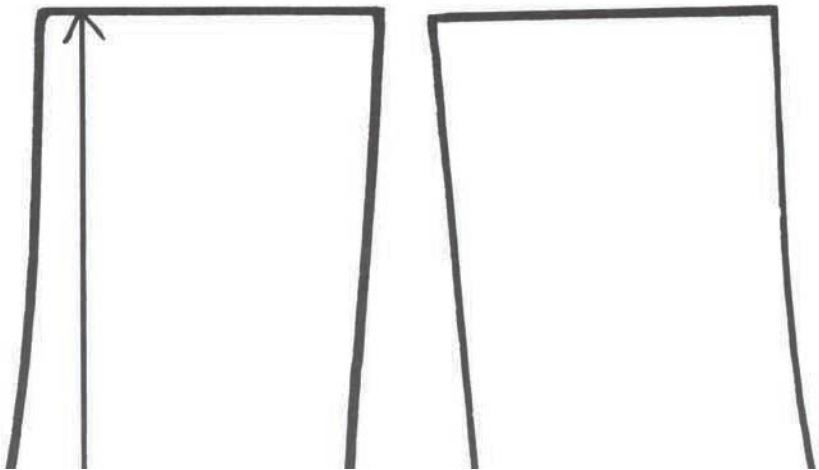
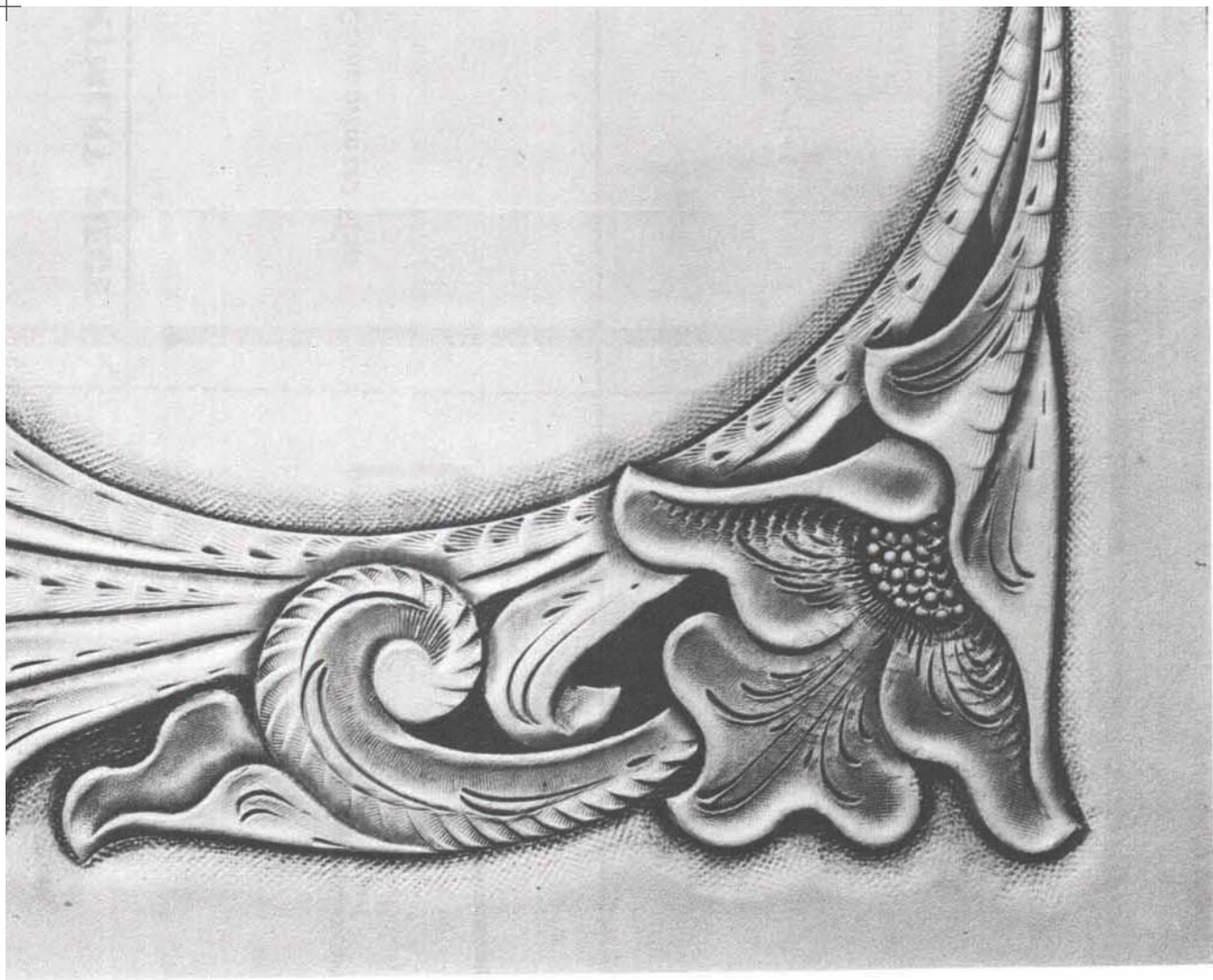

STEP 1:

PREPUNC

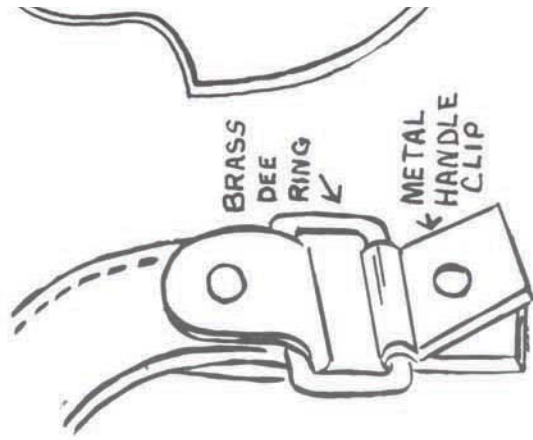

BRASS
DEE
RING

METAL
HANDLE
CLIP

1. Place metal handle clips over brass top hole in tab, one hole is pre-punched, but the other top hole is i

STEP 4:

S124 EDGE I



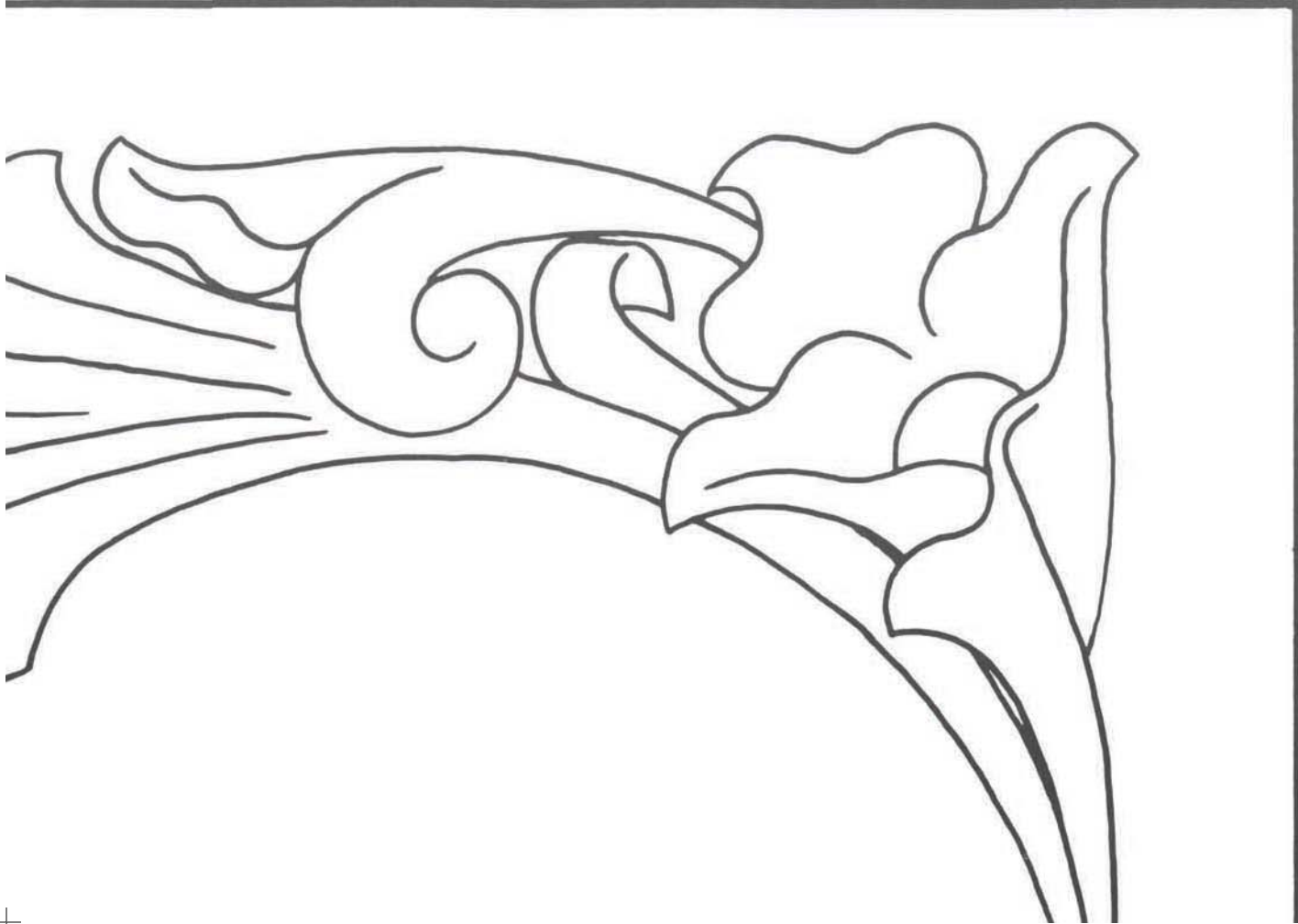

SHOE COMPARTMENT F

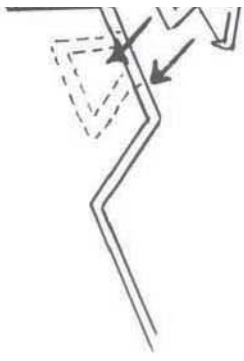

4. Now bevel and burnish ment and its flap, using the Slicker. Now install eyelet. Eyelet is installed simply through the leather and s the leather.

HOW TO

Western D

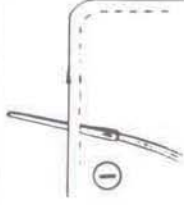

1. Start on top side.



2. Loop



4. Note you pick up (or go under) two strands, entering from top side. This is really where you start the double lace.

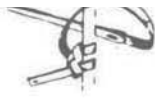

5. Same as step continue until



7. Corners should be rounded. Lace through corner hole or slit twice. (You can lace through corner hole three times, if you prefer).

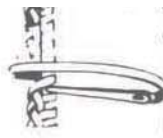

8. You are back point. Notice This indicates removed, so will appear as



10. Completion of the tie-in.



11. Cut off end against projection. Cement end leather.

I without written permission.)

GUSSET PATTERN

(see reverse side for position)

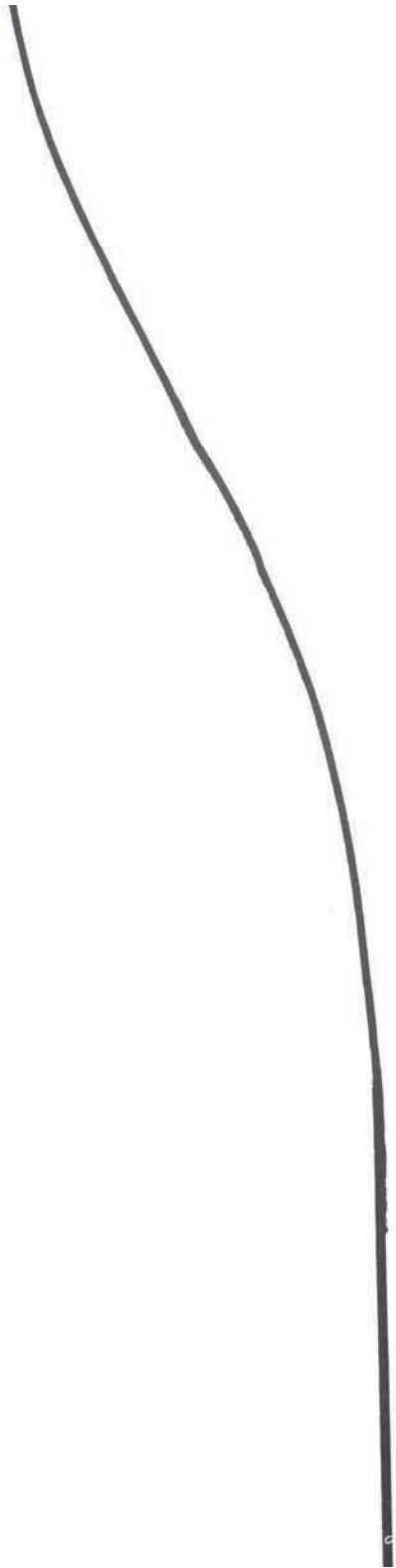

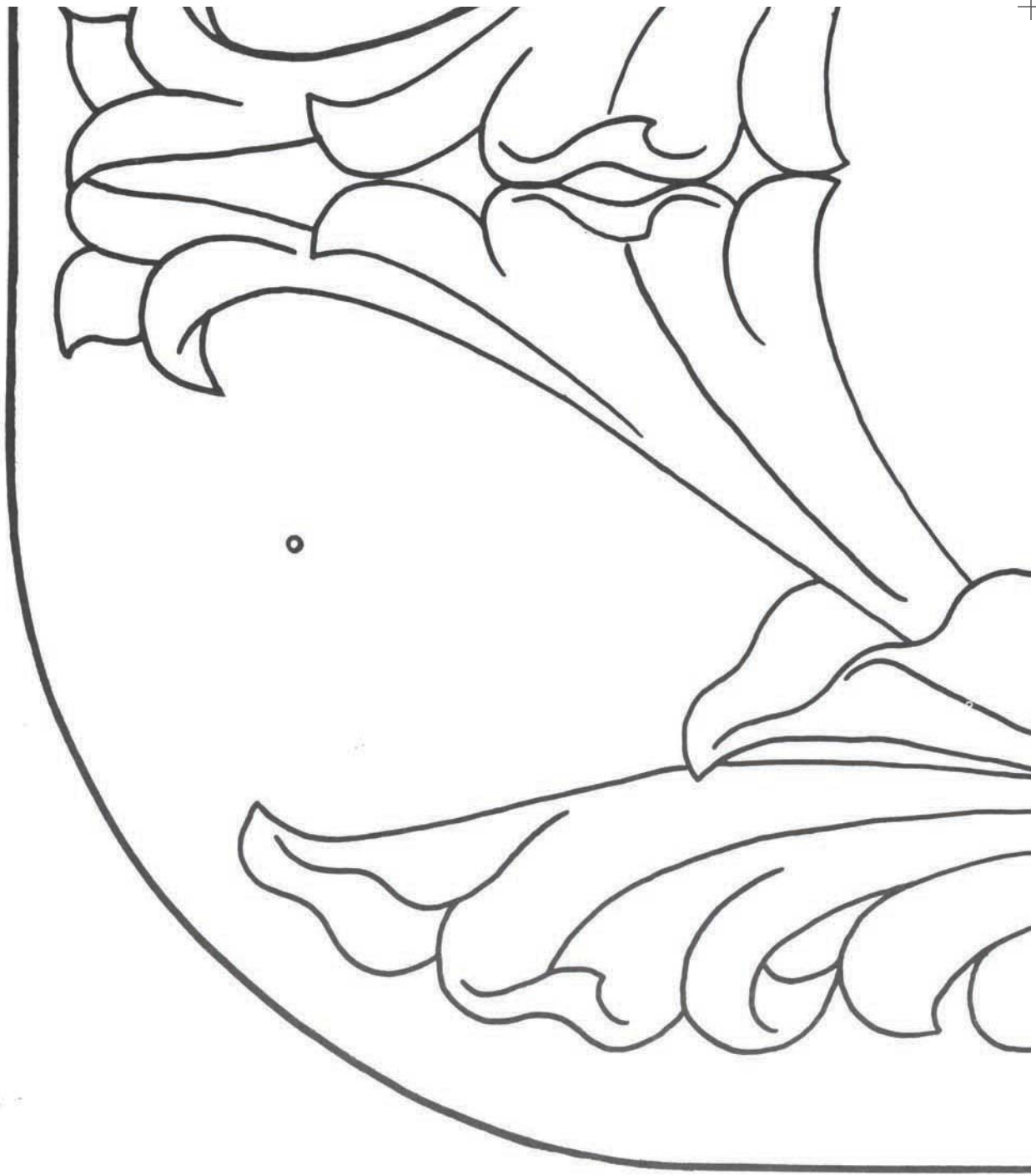

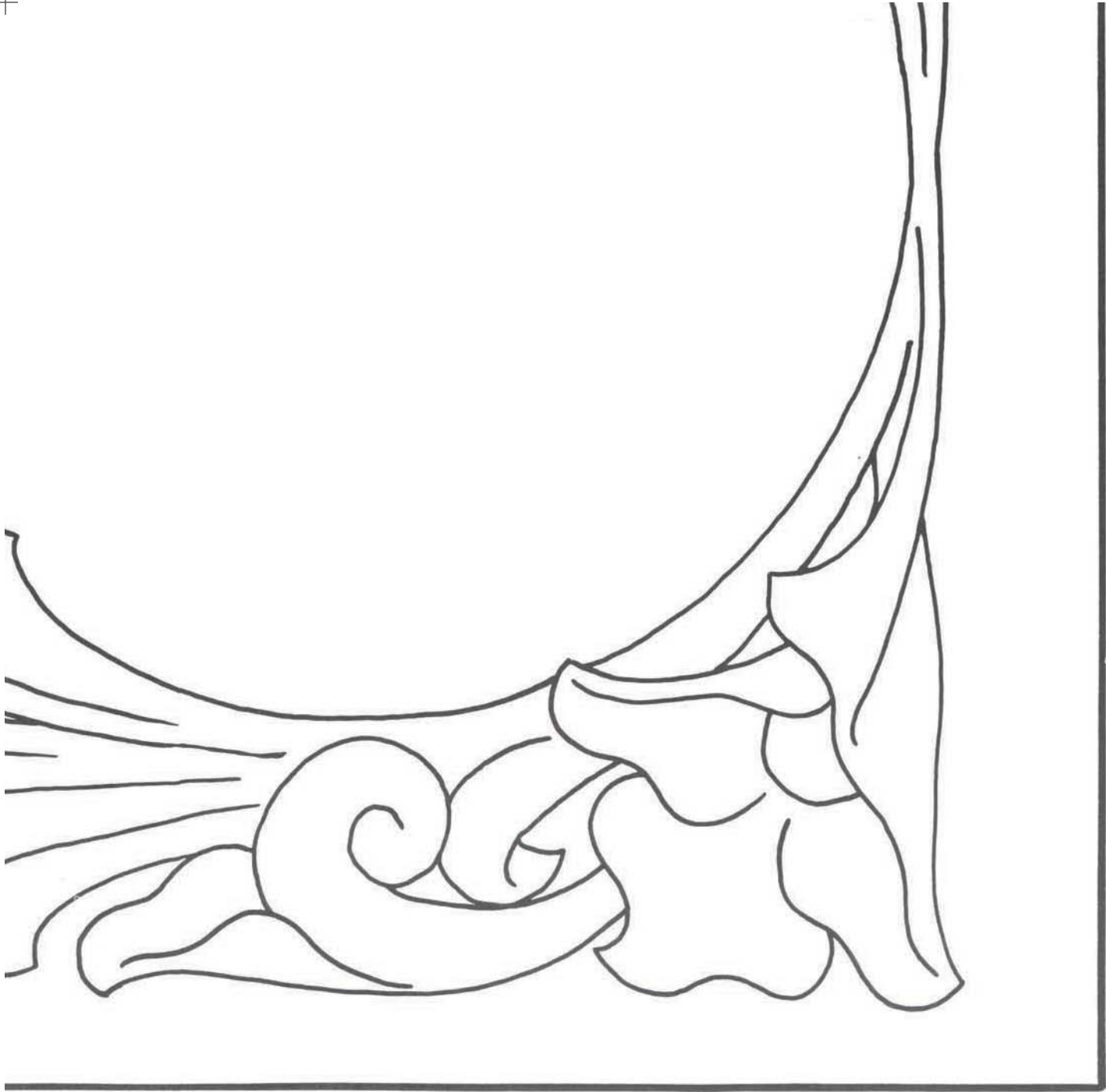

Tracing Pattern

(No part of this or any other page may be re-printed)

PRINTED IN USA



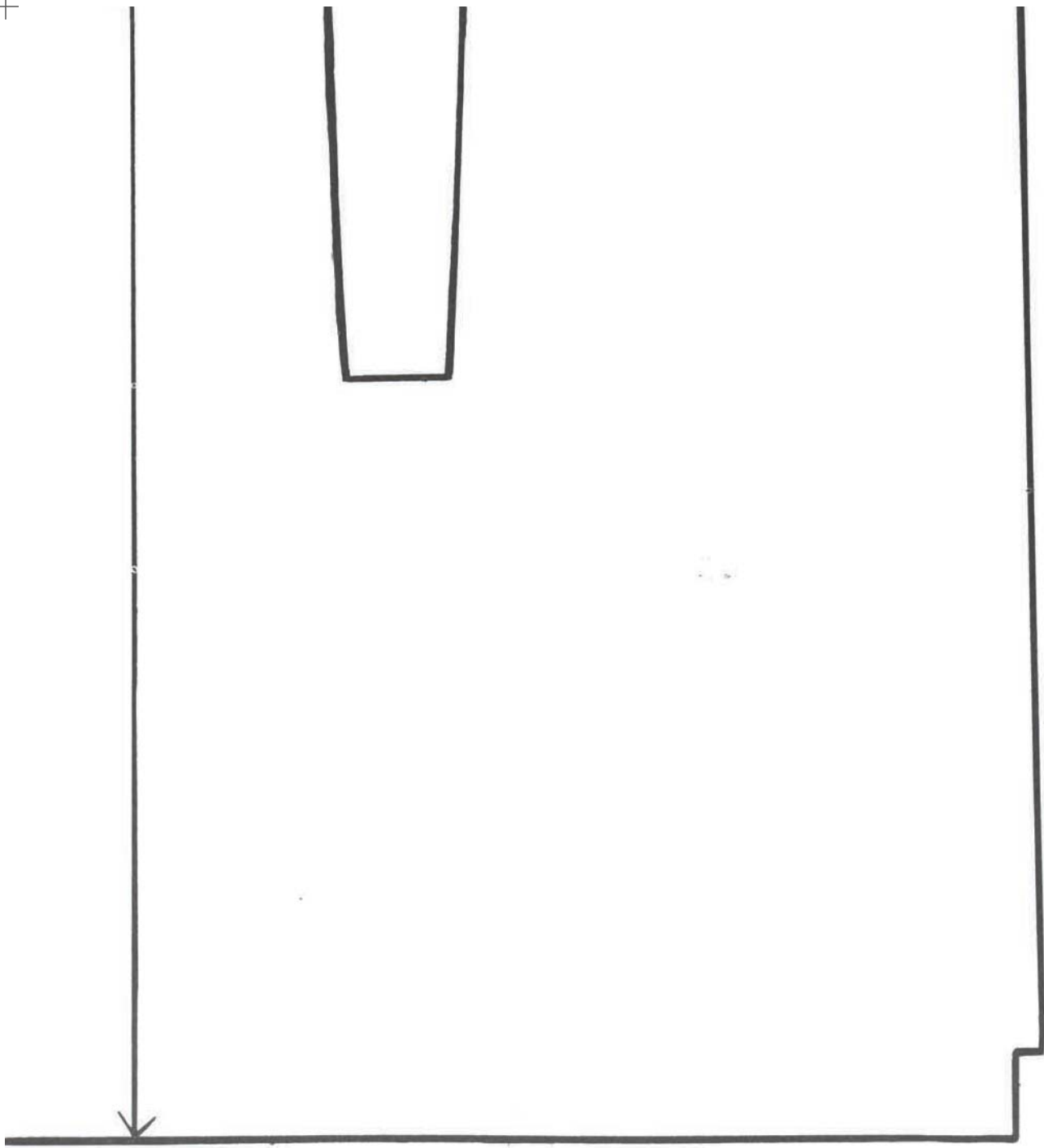
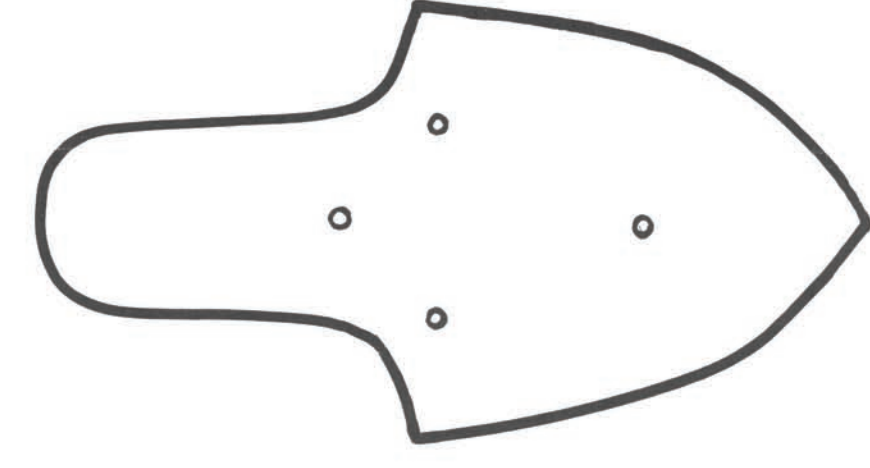
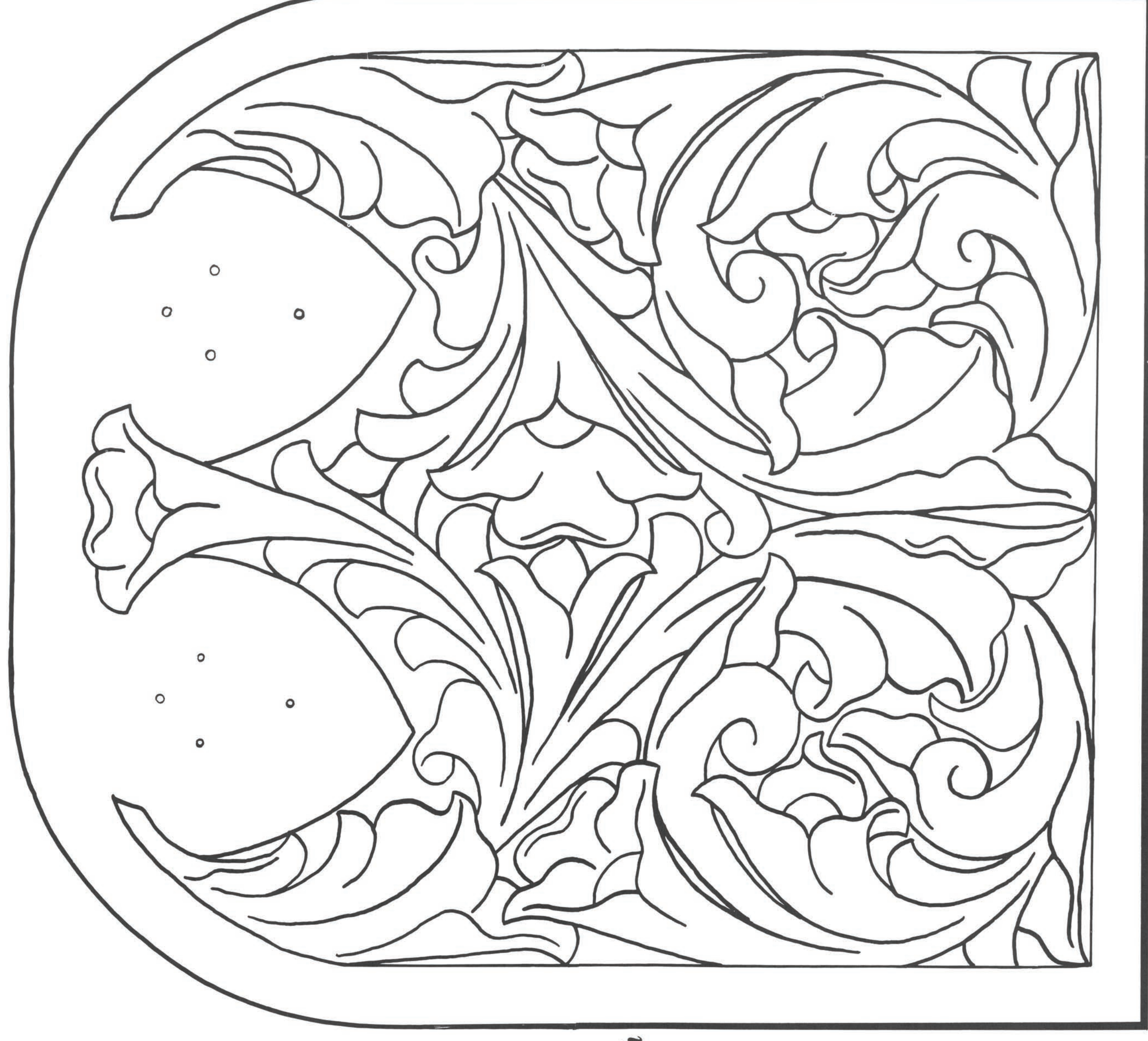

PHOTO-CARVE PATTERN



TRACING PATTERN



HANDLE STRAP TAB

IMPORTANT
Before Carving... Read This!

Prevent Leather Stretch

Before dampening and carving leather, cement heavy wrapping paper to leather's flesh side. This will keep leather from stretching while you carve. Use rubber cement so you can peel paper off after you've finished carving and stamping.

Transfer Design

Transfer pattern from the instruction sheet to the leather with a sharp pencil and tracing paper. Trace off design from "Tracing Pattern." Then re-trace this design on to dampened leather. Use paper clips or masking tape to hold tracing paper on leather.



PRINTED IN U.S.A.
(No part of this or any other page may be reproduced without written permission.)

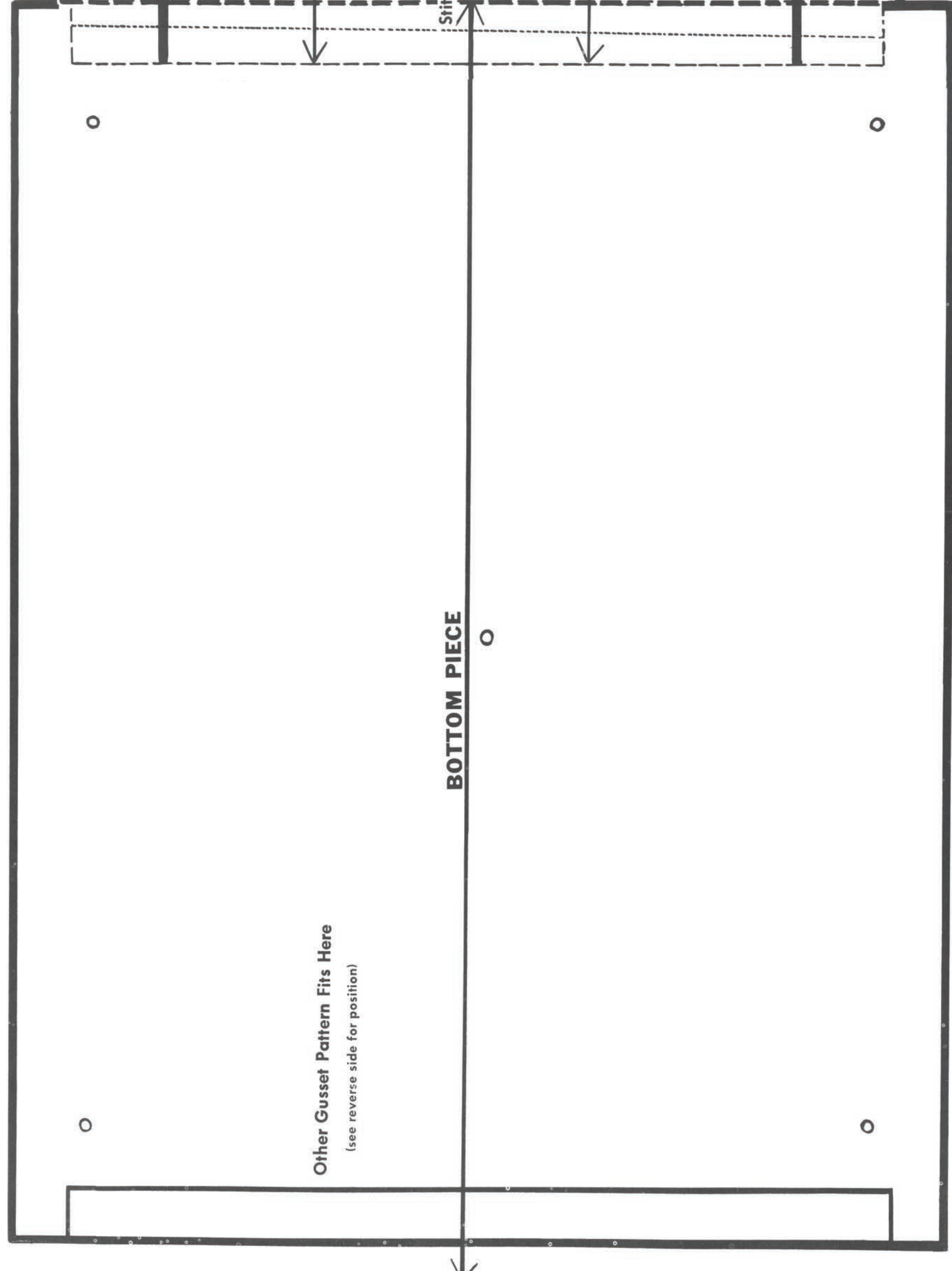

Stitching lines of Shoe Compartment

Stitching Lines for Shoe Compartment Flap

GUSSET PATTERN

HOW TO CARVE YOUR LEATHER PROJECT



PREPARING THE LEATHER

1. Use a sharp knife to remove the top layer of the leather. Cut along the outer edge of the leather. Remove the outer piece. Do not get leather staining wet.

2. Use tracing paper to trace design outlines from pattern. Clip tracing to easy to use.



Step 1 - Preparing the leather. Cut out the outer piece of the leather. Do not get leather staining wet.



Step 2 - Tracing the design. Use tracing paper to trace design outlines from pattern. Clip tracing to easy to use.



Step 3 - Dampening. Dampen leather with water. Use a brush to apply water to the leather. Do not get leather staining wet.



Step 4 - Rubbing. Rub the leather with a brush. Use a brush to apply water to the leather. Do not get leather staining wet.



Step 5 - Rubbing. Rub the leather with a brush. Use a brush to apply water to the leather. Do not get leather staining wet.



Step 6 - Rubbing. Rub the leather with a brush. Use a brush to apply water to the leather. Do not get leather staining wet.

Leather Piece to Line Shoe Compartment

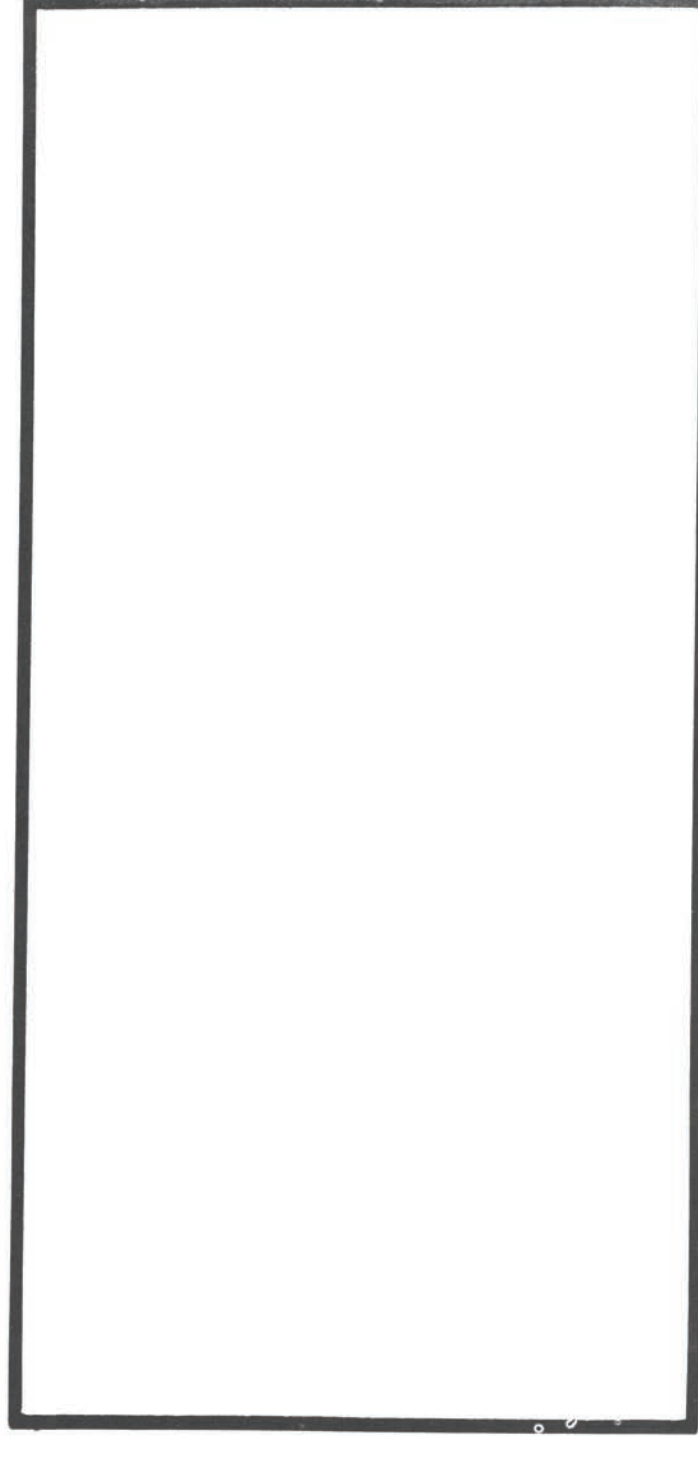

Shoe Compartment Flap

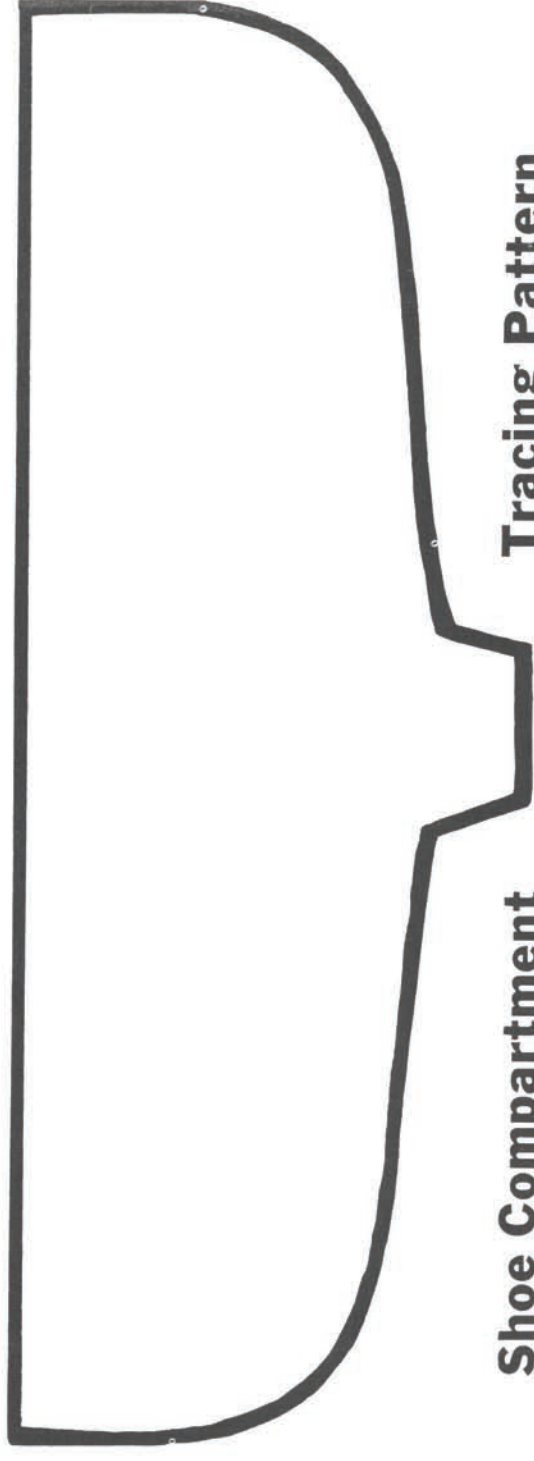

Shoe Compartment

Tracing Pattern

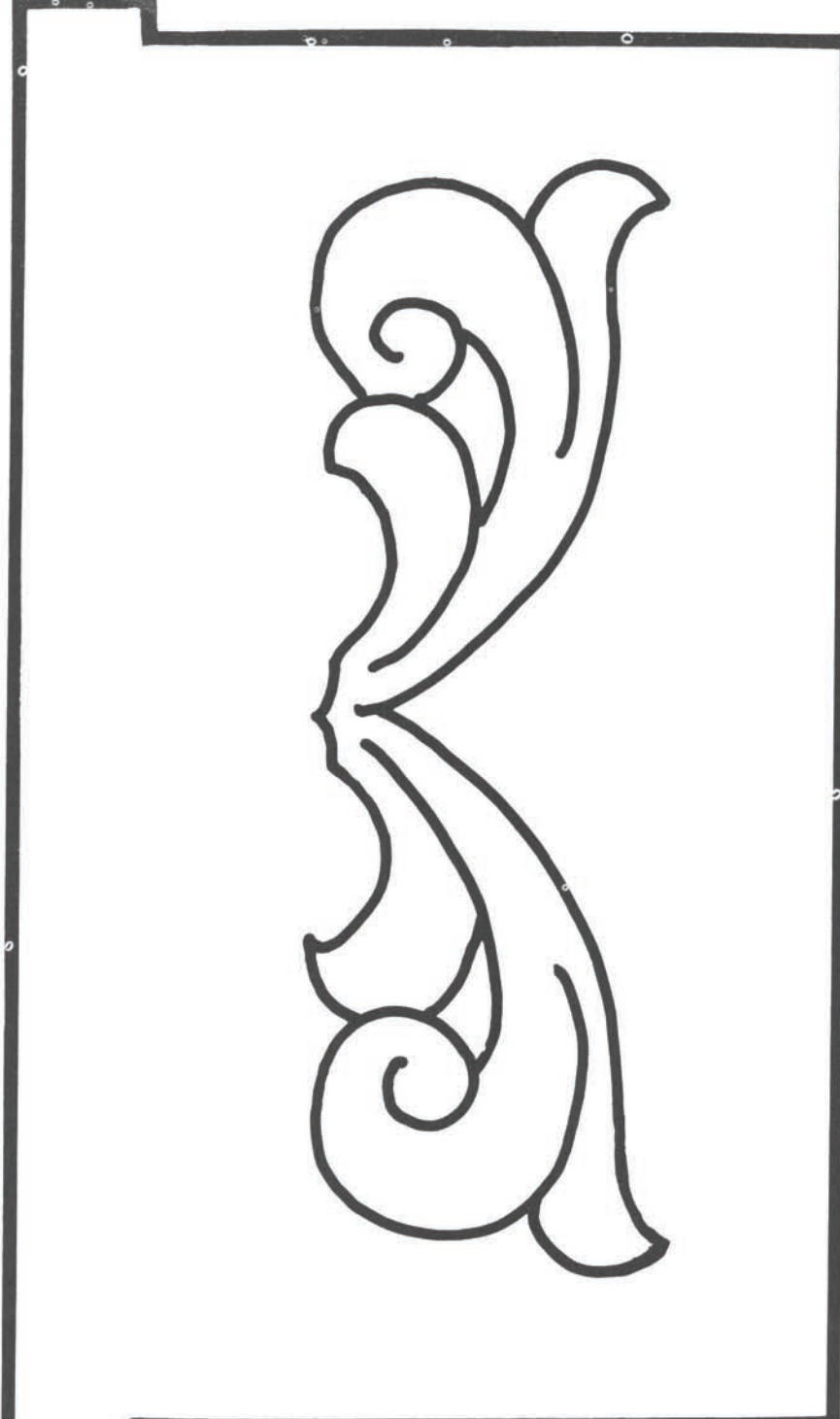

Shoe Compartment Photocarve Pattern

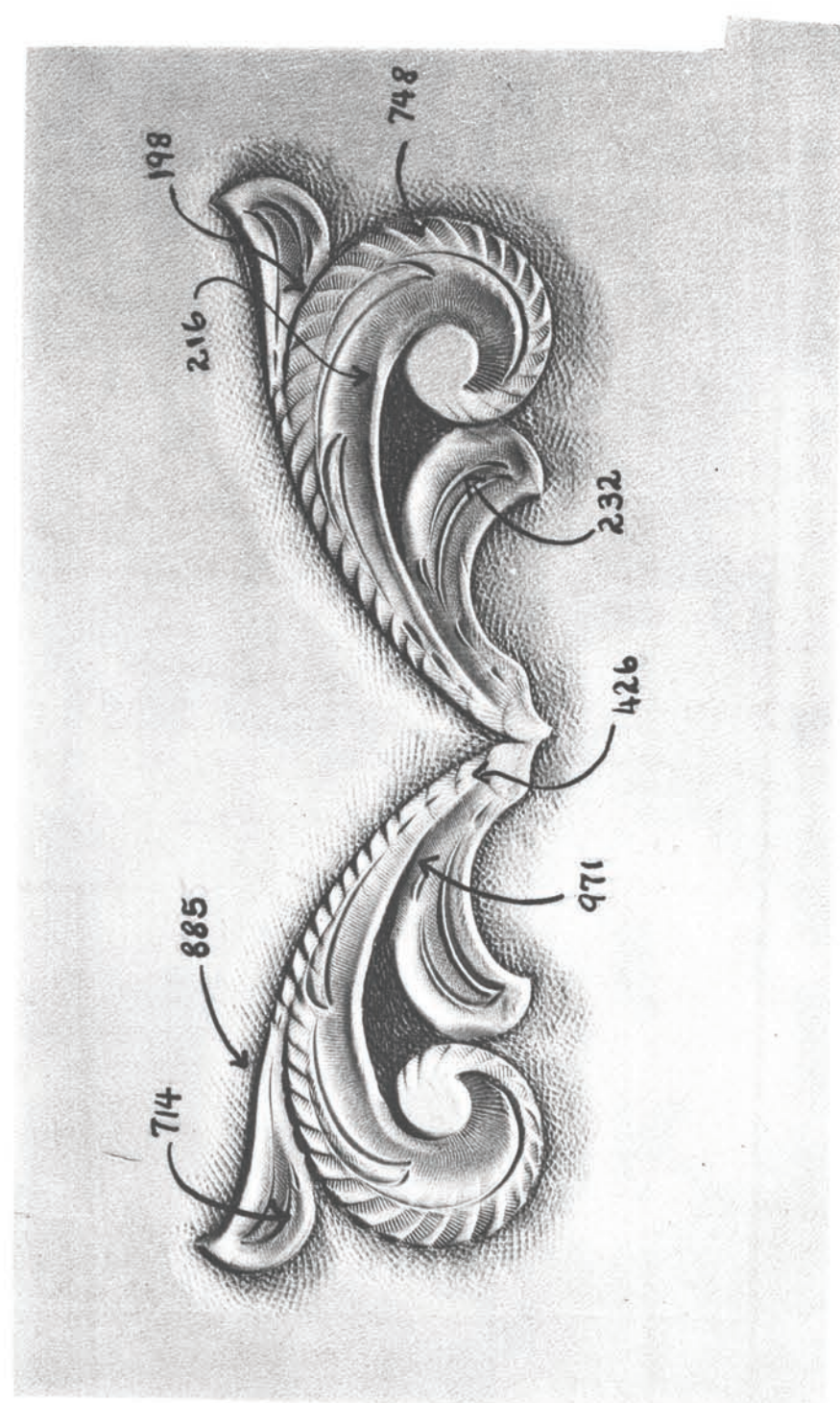

D CARVE YOUR LEATHER PROJECT



n or smooth side up on a smooth board.
 other sopping wet.
 ncs from pattern. Clip tracing to damp

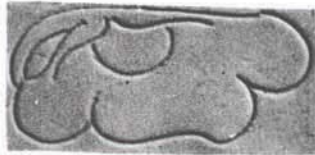

Step 1—Tracing Design
 Trace the outline of the design on leather with tracing tool or sharp pencil. If leather becomes dry, dampen it again. When it turns back to its natural color, resume work.



Step 4—Shading
 Use shaver to add shading or deep burnished color to leather. Use on flower petals, leaves, etc.

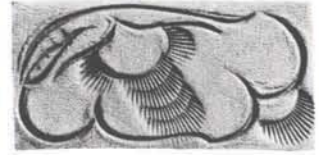

Step 3—Camouflage
 Use veiner to add decorative effect on scrolls, leaves, stems, etc.

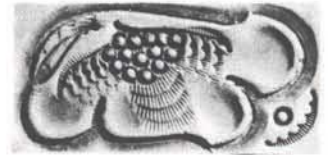

Step 6—Veiner and Seeder
 Use veiner to add decorative effect on scrolls and flowers. Seeder to complete flower centers.



Step 7—Background
 Use background tool to stamp down background areas, dark areas on pattern. Add decorative cuts with your swivel knife. When all tooling and stamping have been completed, clean and polish leather with Tan-Kote. Then apply a protective coating of Neat-Lac — Tandy's special leather finisher containing essential oils and waxes to preserve and protect leather.

Piece to Line Shoe Compartment

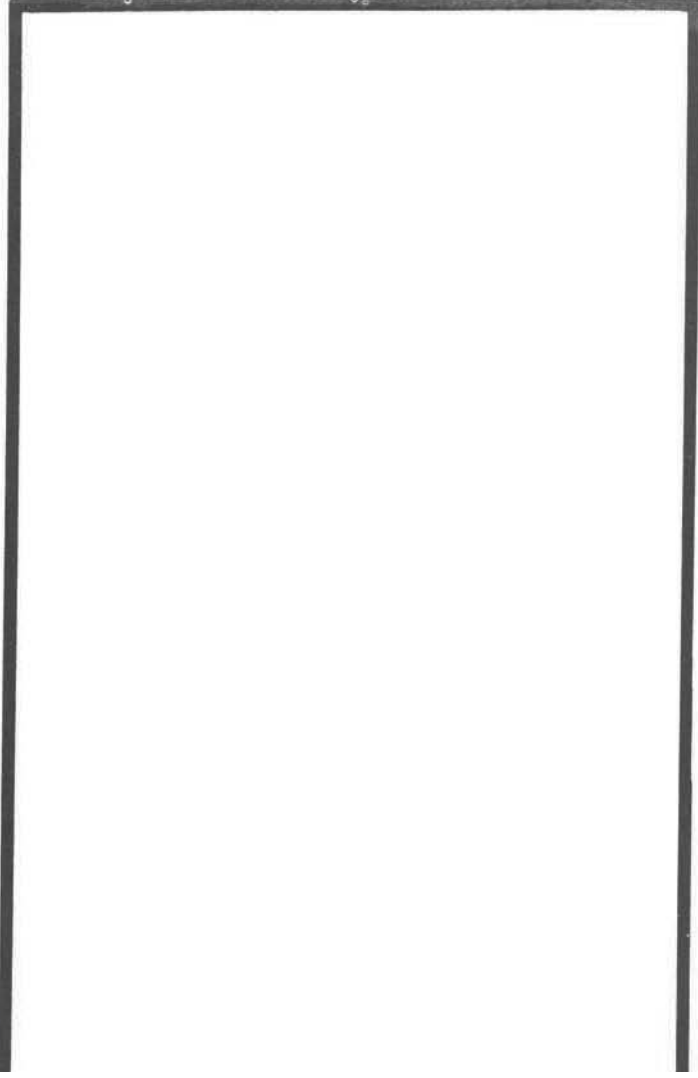

Shoe Compartment Flap

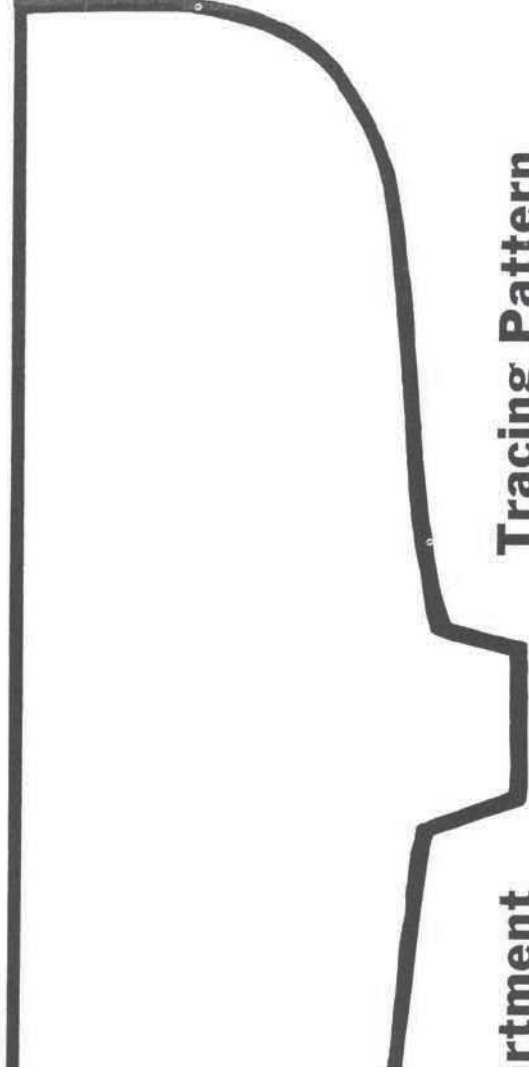

Tracing Pattern





partment Photocarve Pattern

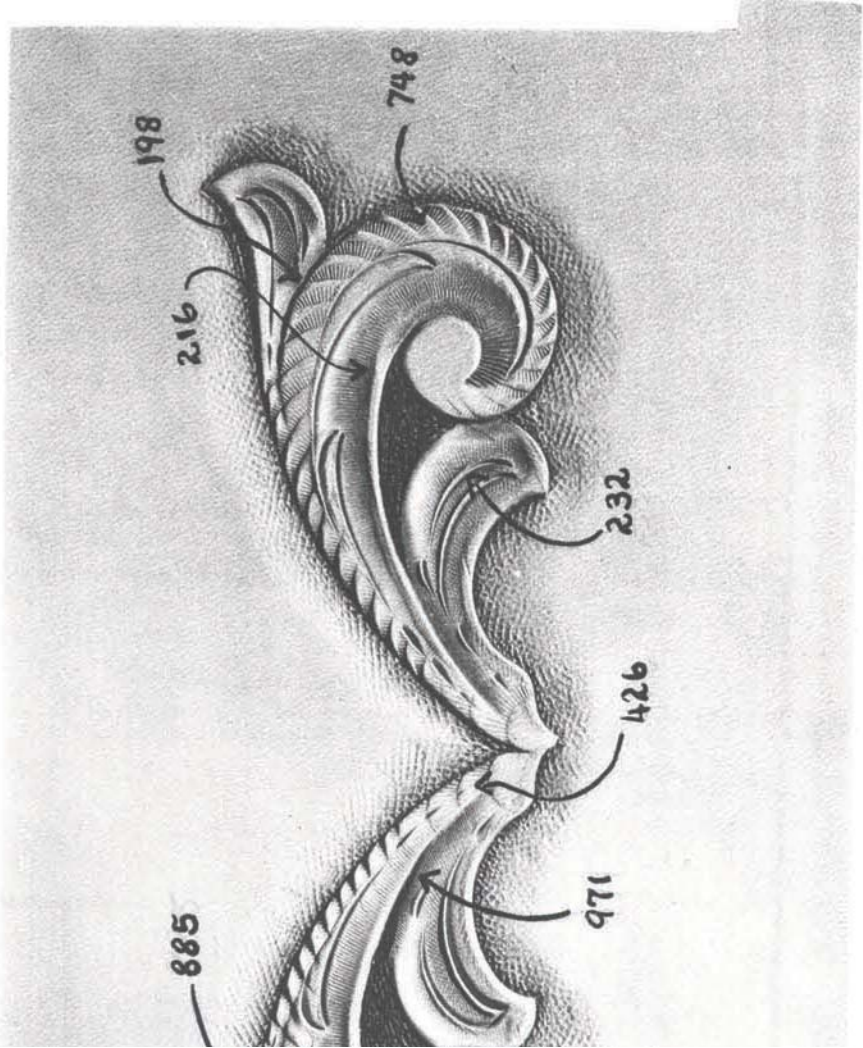

TERN

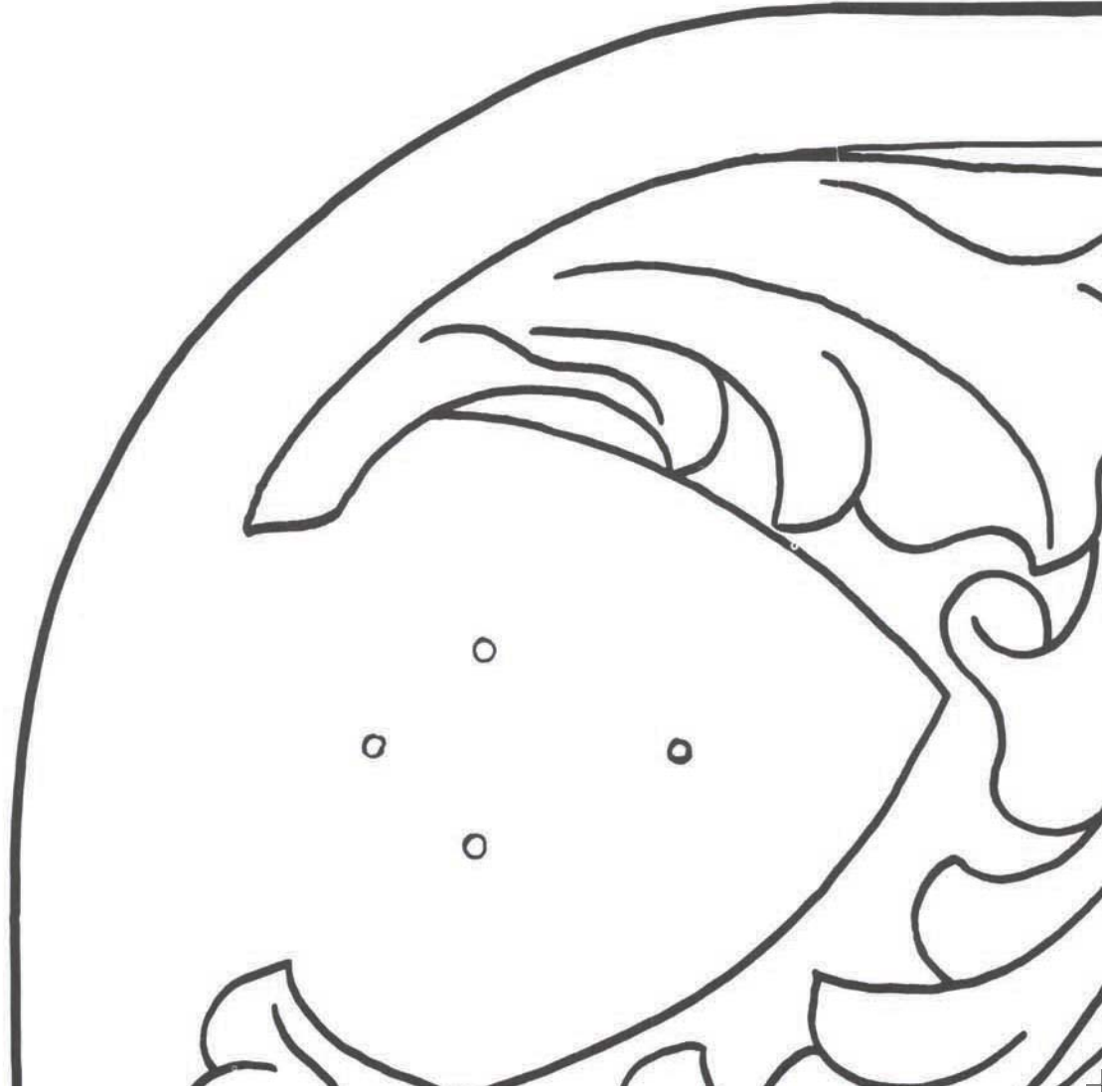

HOW TO

PREPARING THE LEATHER

- A. Use a sponge to dampen leather.
- B. Spread the leather to be decorated grain side up. Dampen the entire piece. Do not get too wet.
- C. Use tracing paper to trace design onto leather.



Step 2—Carving

Use swivel knife to carve design. Carve lines in the following order: flowers, leaves, scrolls, etc.



Step 5—Beveling

Use beveler to stamp down one side only. Push beveler along inside of swivel knife cut. Smooth even bevel is very important.

Leather

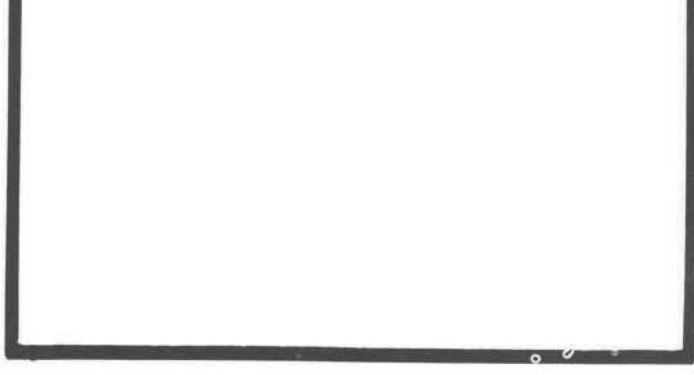

S

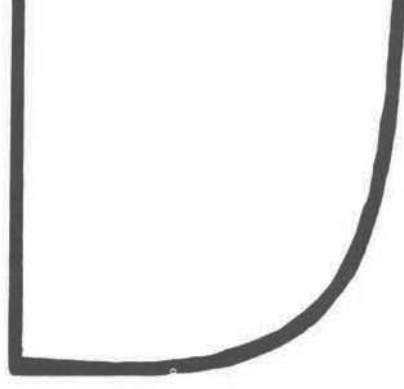

Shoe Compa

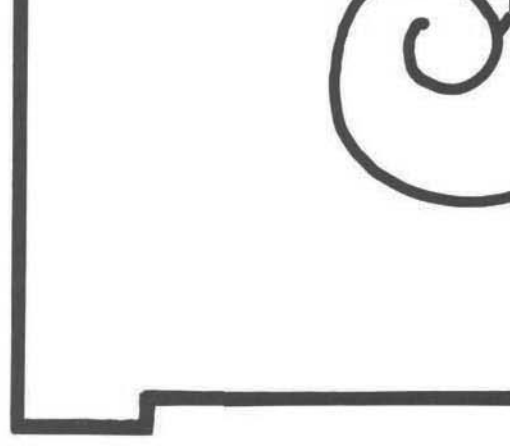

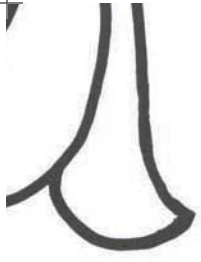

Shoe Com

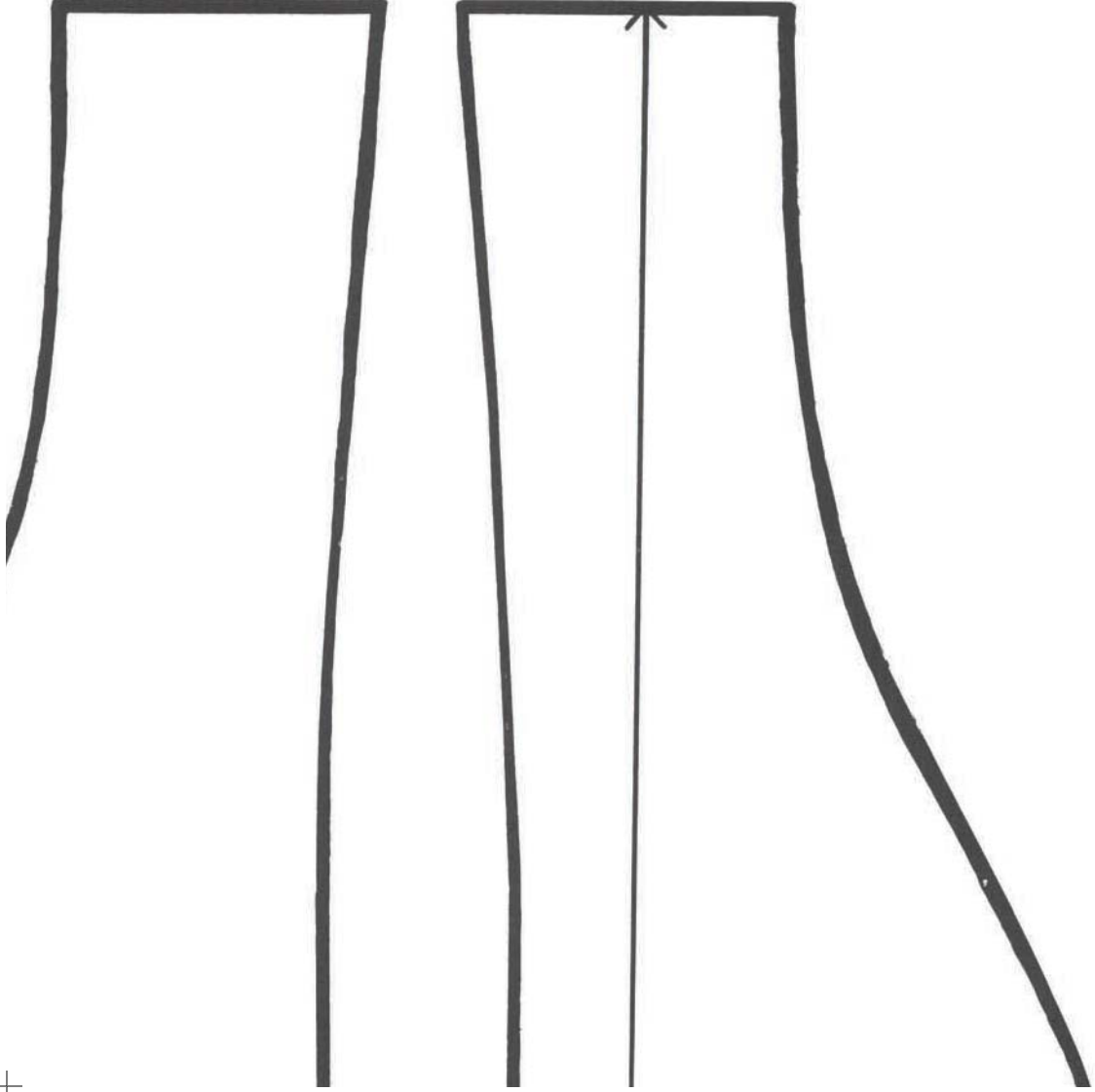
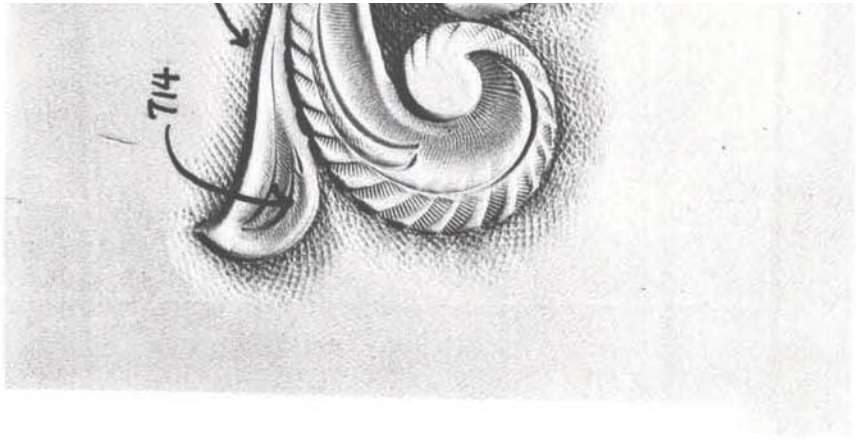

TRACING PAT

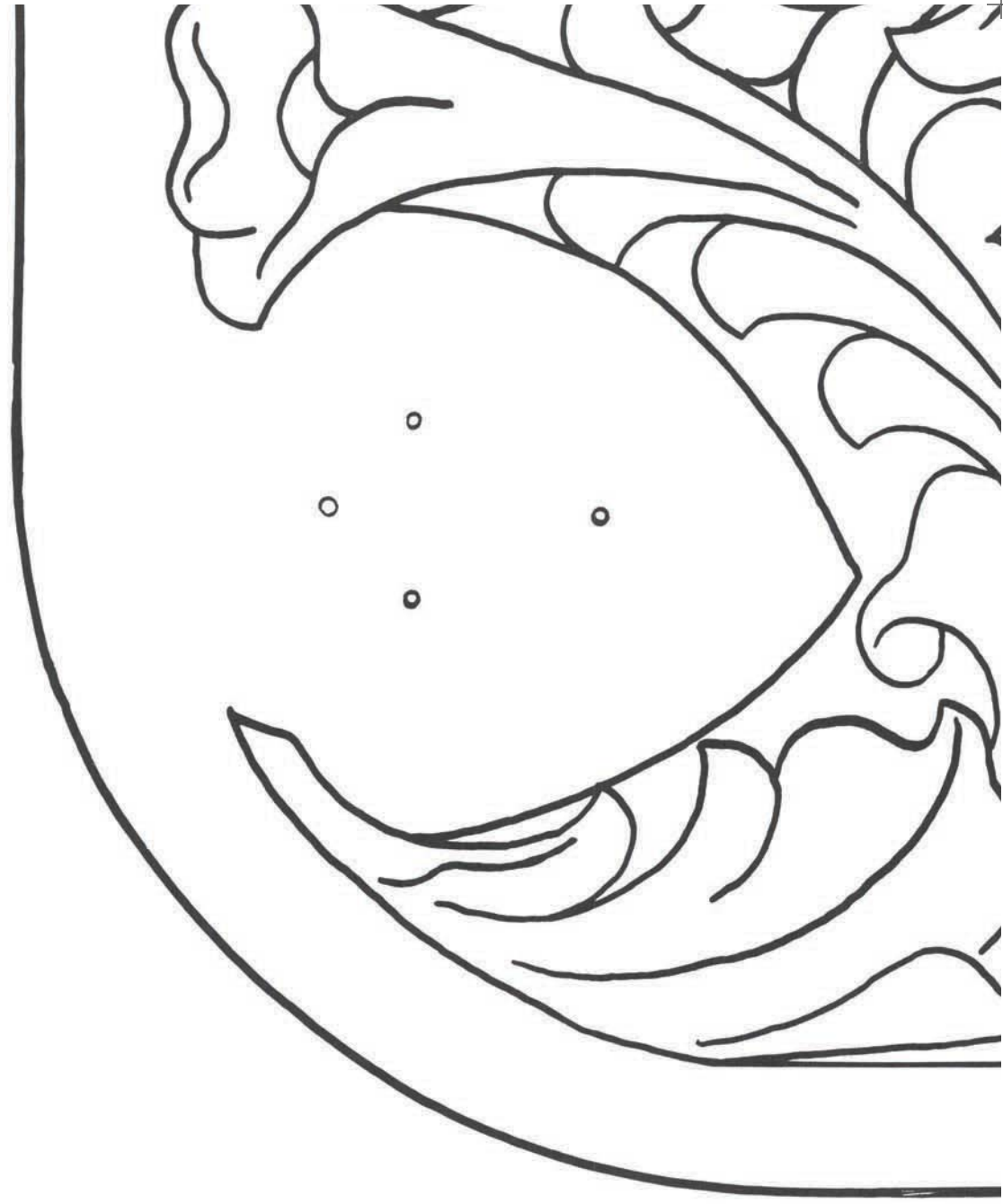

NT

and This!

Stretch

irv-
avy
er's
eep
hile
ce-
per
hed

gn

in-
her
ac-
ign
nen
to
pa-
: to
ith-



(written permission.)



Stitching lines of Shoe Compartment

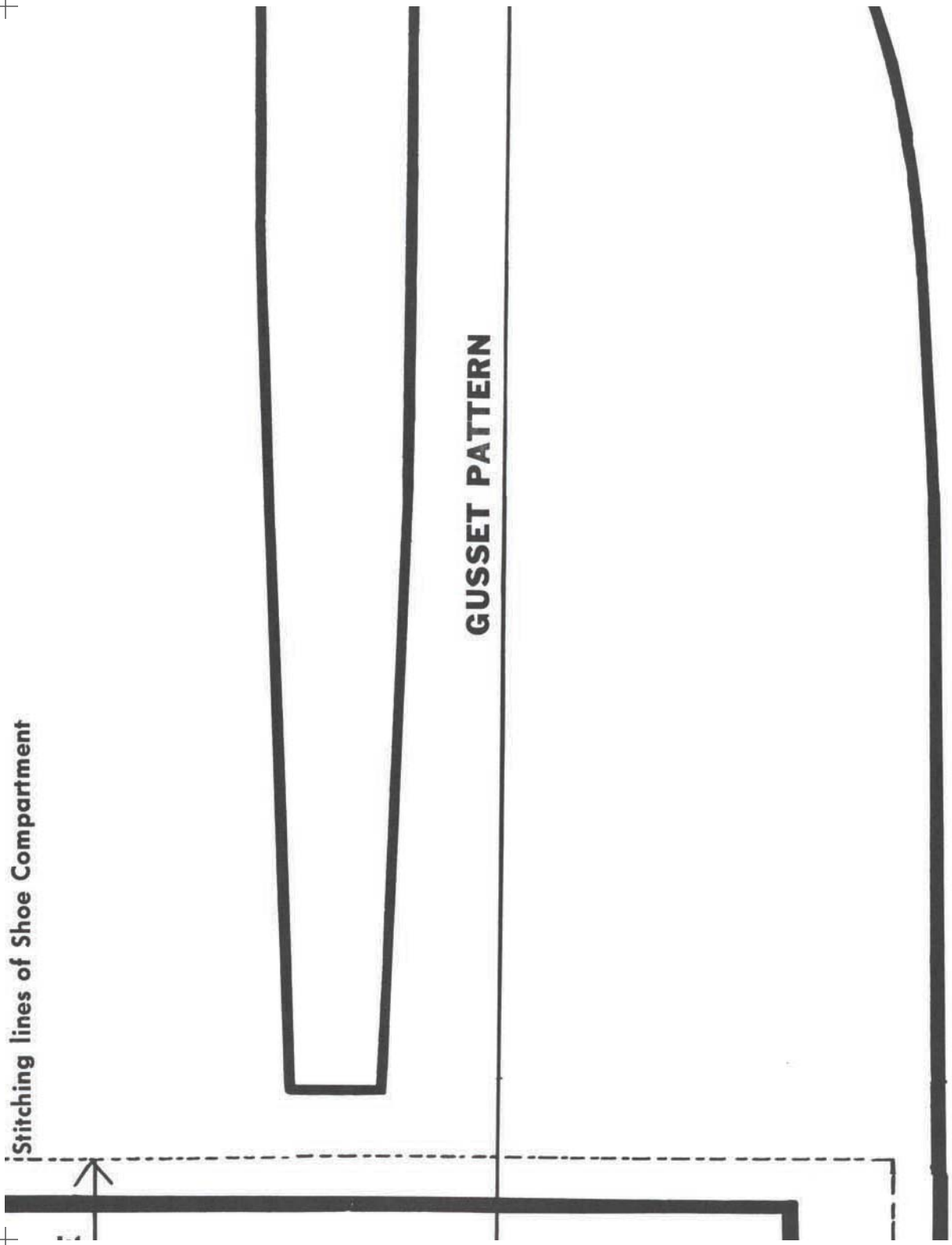

TERN

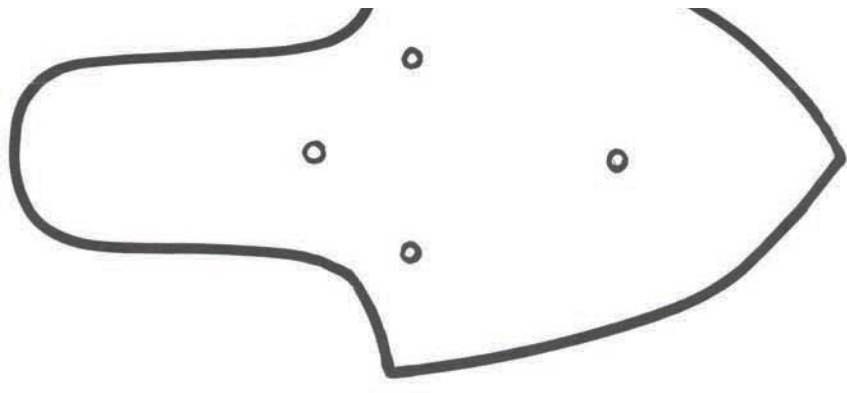

HANDLE STRAP TA

IMPORTANT!

Before Carving... Read

Prevent Leather

Before dampening and carving leather, cement heating leather, cement heating wrapping paper to leather flesh side. This will keep leather from stretching while you carve. Use rubber cement so you can peel paper off after you've finished carving and stamping.

Transfer Design

Transfer pattern from the instruction sheet to the leather with a sharp pencil and tracing paper. Trace off design from "Tracing Pattern." Then re-trace this design on dampened leather. Use paper clips or masking tape to hold tracing paper on leather.



PRINTED IN U.S.A.

(No part of this or any other page may be reproduced without

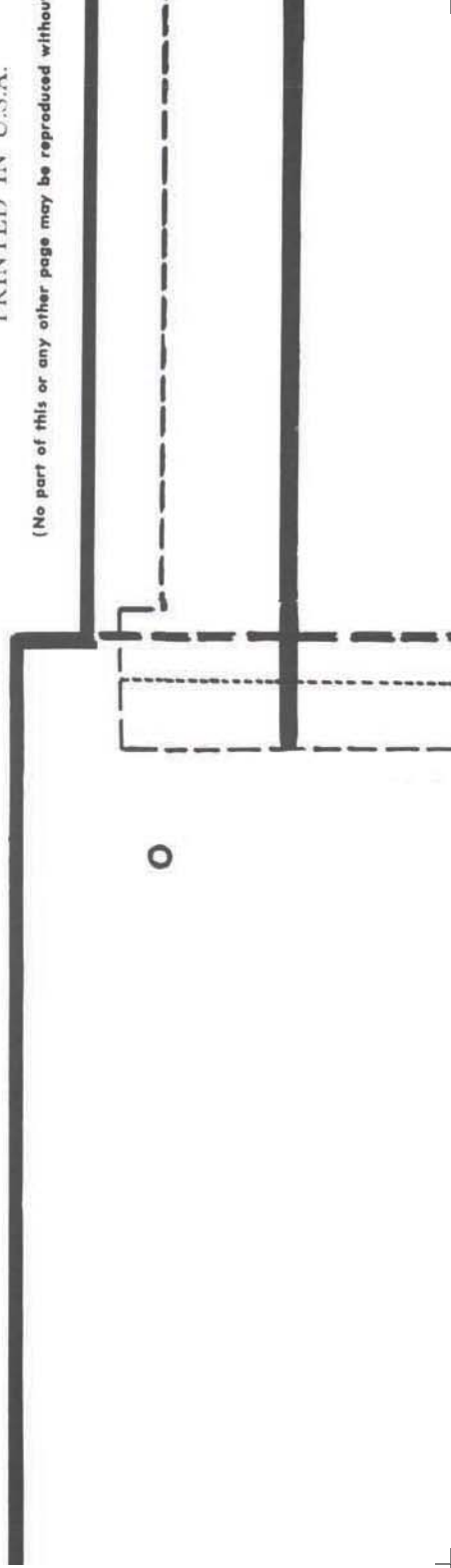
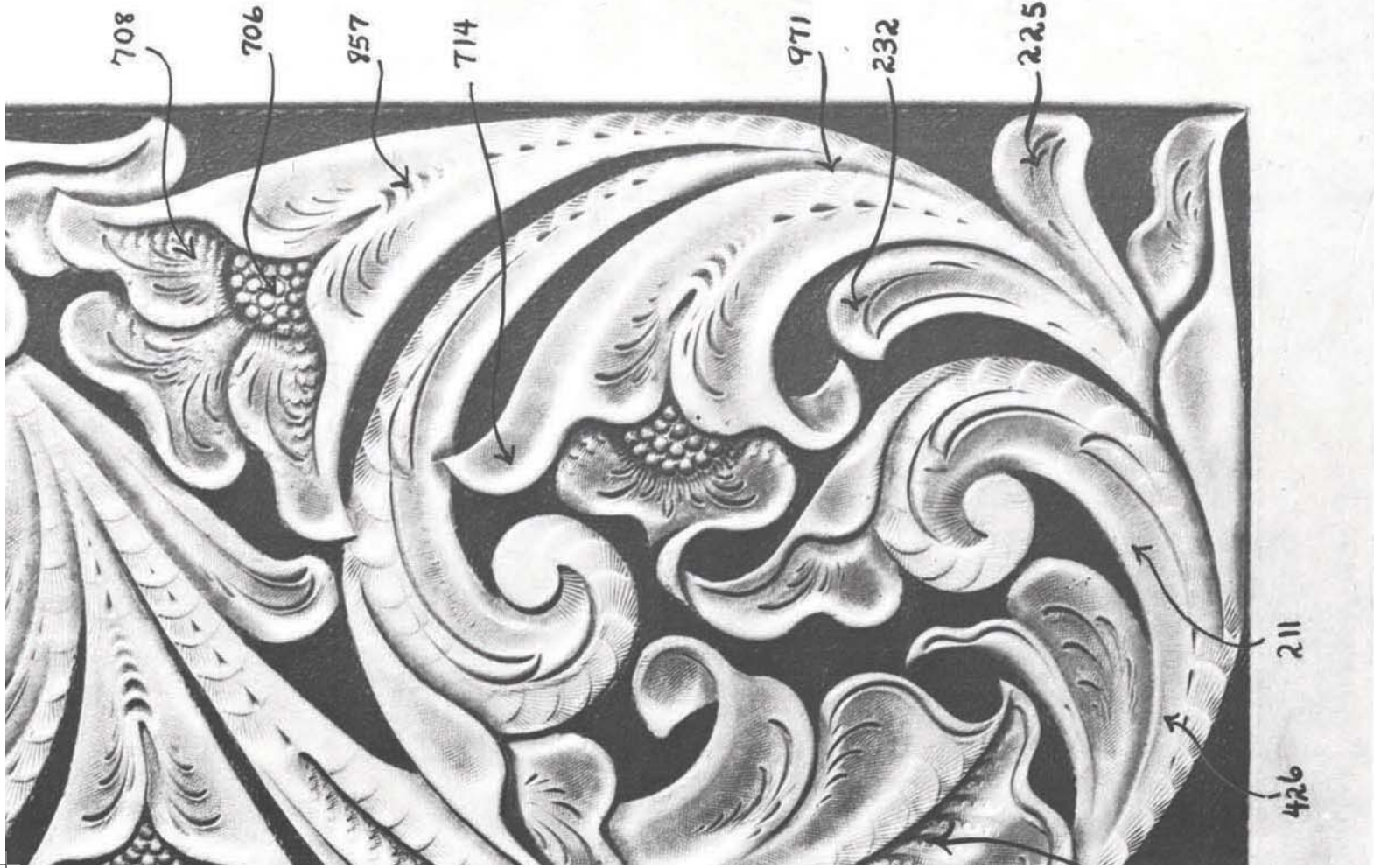

SHOE COMPARTMENT PIECE

Stitching Lines for Shoe Compartment Flap

Cut gusset where heavy line indicates.

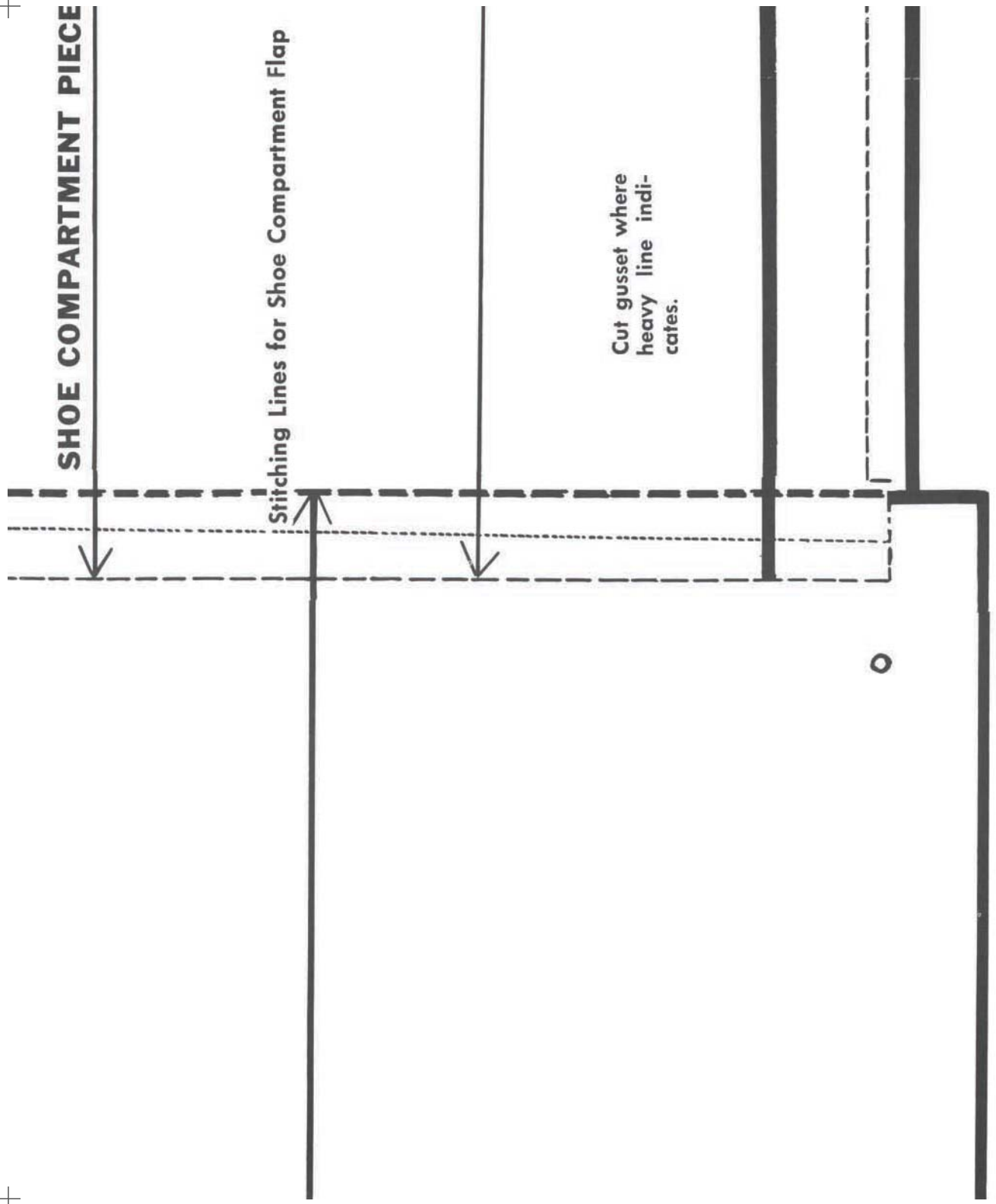
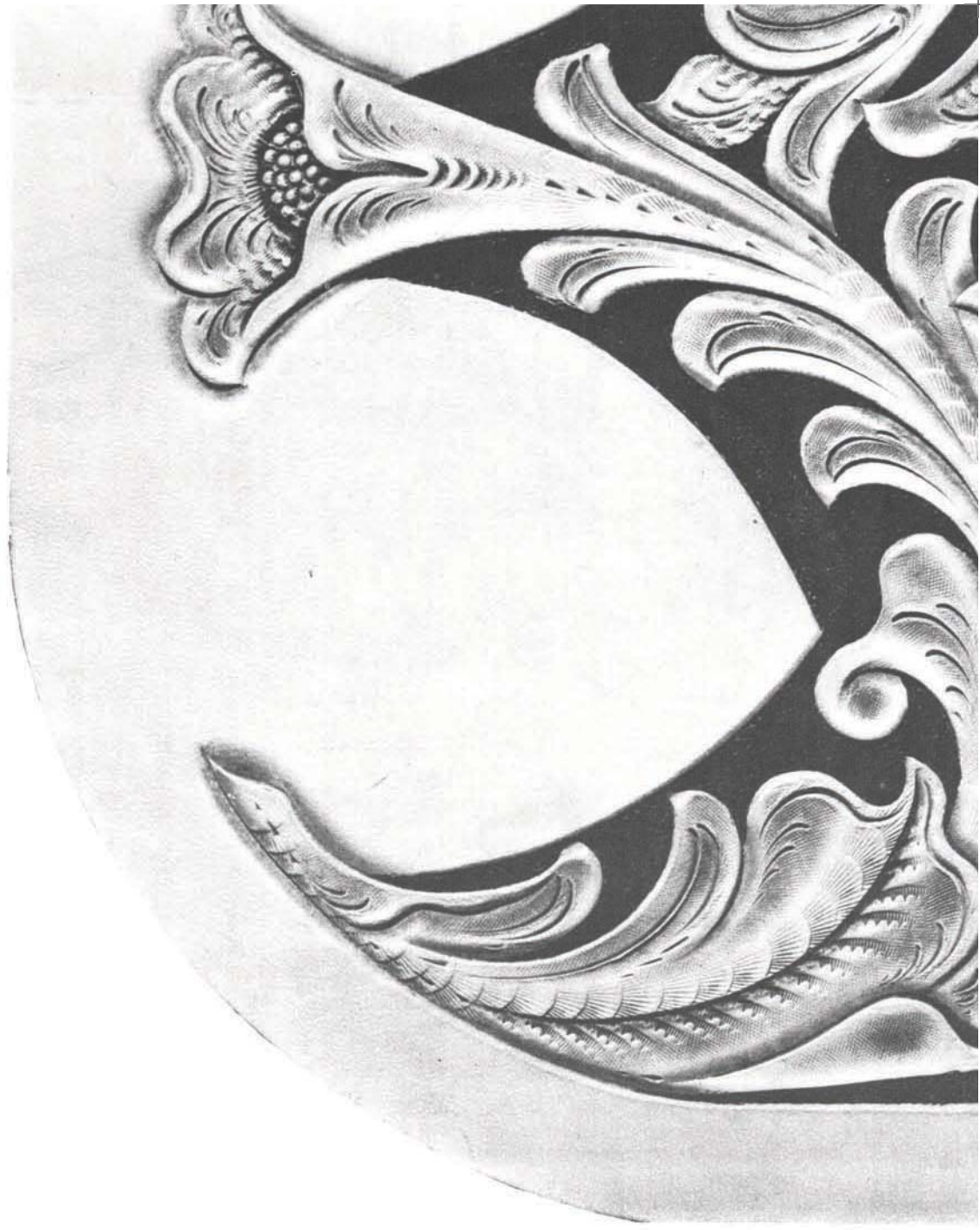

PHOTO-CARVE PAT





886

701

412

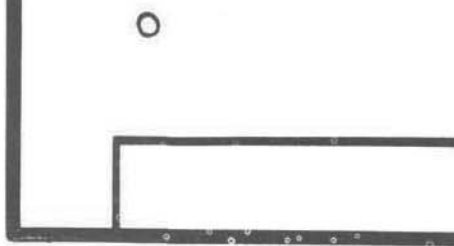

Other Gusset Pattern Fits Here
(see reverse side for position)

BOTTOM PIECE

○

○

