



From Tony Laier's Bench:

Motorcycle Saddle Bags

(With Removable Bags)

Each Bag Approx. 12-3/4" Wide x 11" Tall x 6-3/4" Deep



NOTE: Saddle Bags can be sized as explained on front part pattern (at right) or sized smaller or larger. Hardware, straps and some holes may need to be adjusted for alternate sizing.

YOU WILL NEED:

- Bag Fronts, Flaps, Gussets & Connector Strap 8 To 9 Oz. Leather
- Bag Backs, Handles, Billet Straps & Stiffeners 9 To 10 Oz. Leather
- Buckle Straps 6 To 7 Oz. Leather
- 4 Medium Rapid Rivets (#1120-01 Or #1381-12)
- 28 Large Rapid Rivets (#1275-12 Or #1375-12)
- 4 Clips With 3/4" Dees (#1120-01)
- 4 (1") Single Prong Roller Buckles (#1516-02)
- 4 (1") Strap Keeper Formed Loops (#1137-04)
- 4 Bag Clasps (#11506-00)
- 12 Yards 5/32" Latigo Lace
- 8 Yards Waxed Thread & Needles
- 1/16", 1/8" & 5/32" Hole Punches
- 1" Bag (Slot) Punch
- Leather Knife & Skiver Or Safety Beveler
- Adjustable "V" Gouge (#31811-00 Or 8082-00)
- Rivet Setter (#8100-00)
- Jumbo Perma Lok™ Needle (#1193-00)
- 2 Pieces Of Hook & Loop Fastener (each 2" X 9")

CUTTING PATTERNS:

1) Enlarge front part to desired size. Then enlarge remaining pattern parts the same % so all parts will fit together properly.

2) Transfer enlarged patterns to grain side of leather and cut indicated number of parts.

3) Punch all holes where indicated. Hole sizes shown are for the width (255%) sized bags. If yours are different, adjust holes accordingly.

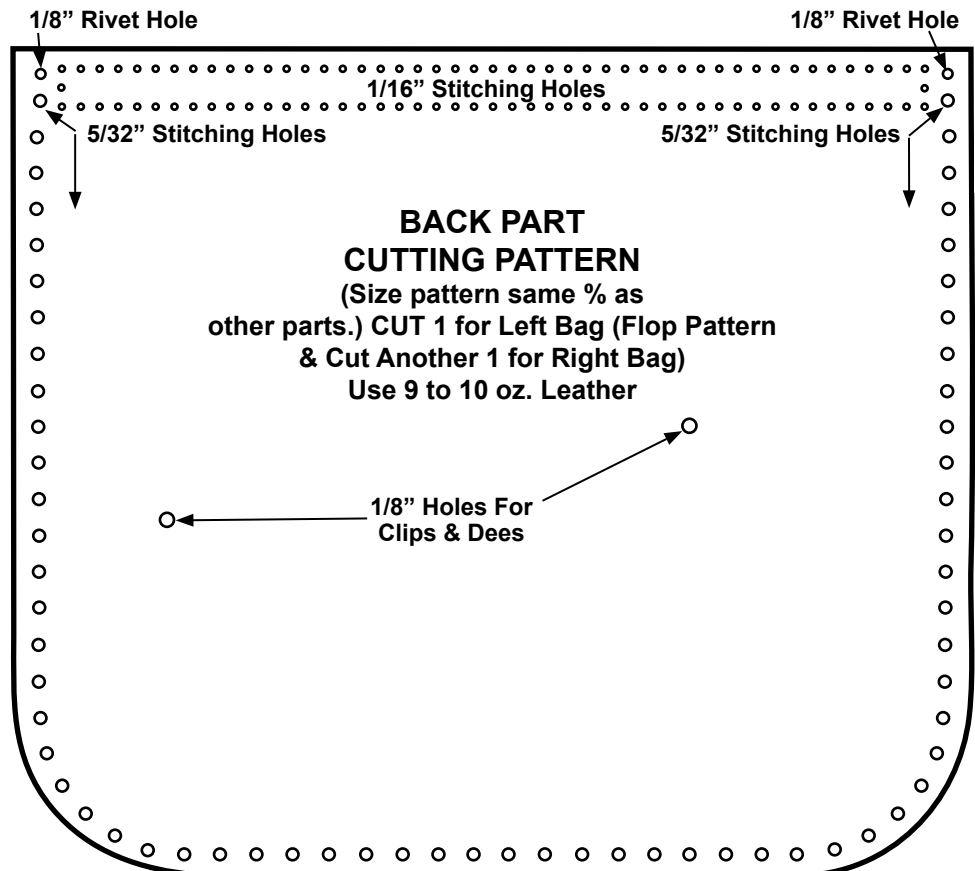
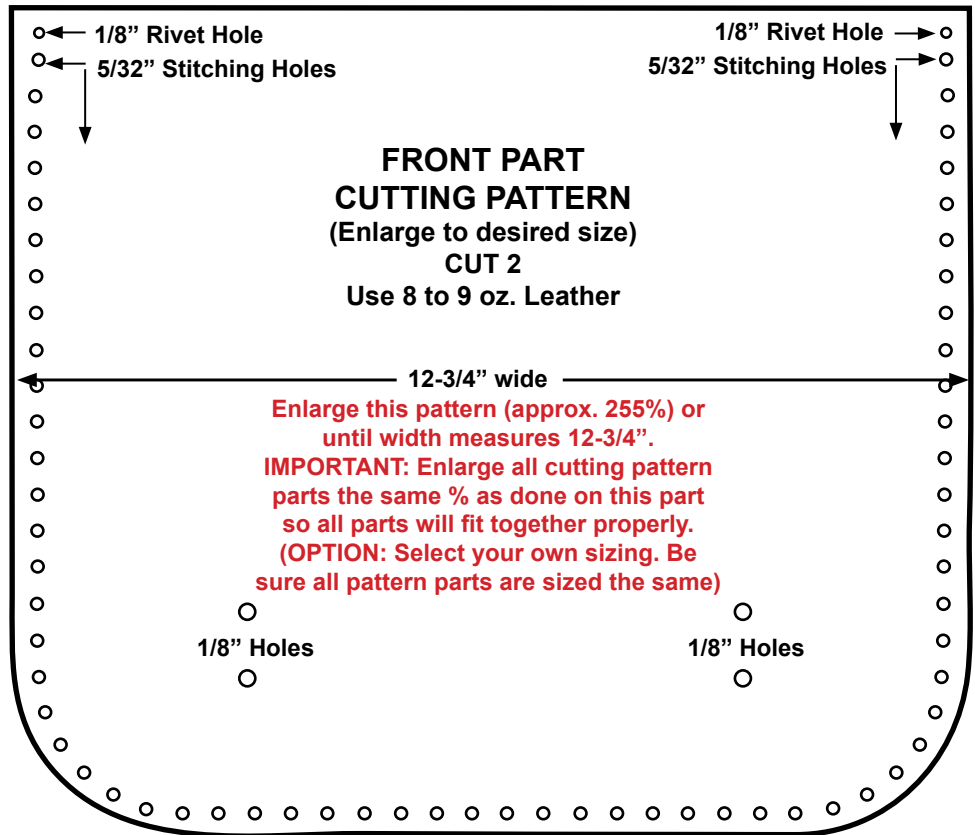

IMPORTANT: Enlarge all cutting pattern parts the same % as done on the FRONT part so all parts will fit together properly.

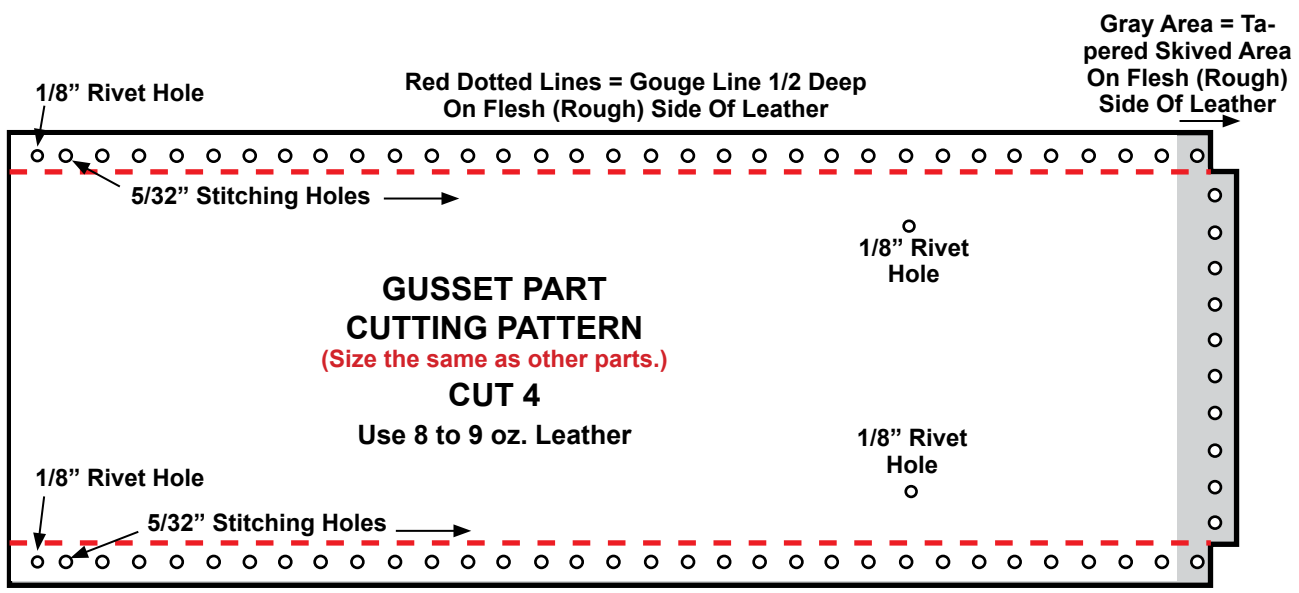
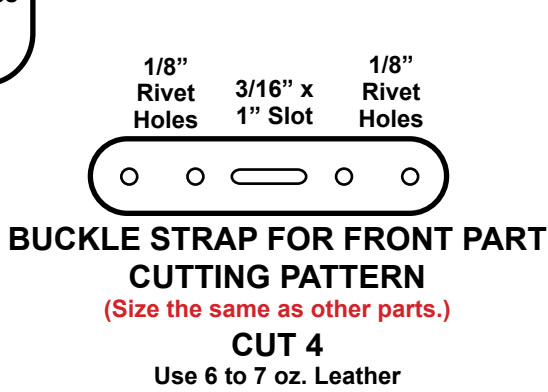
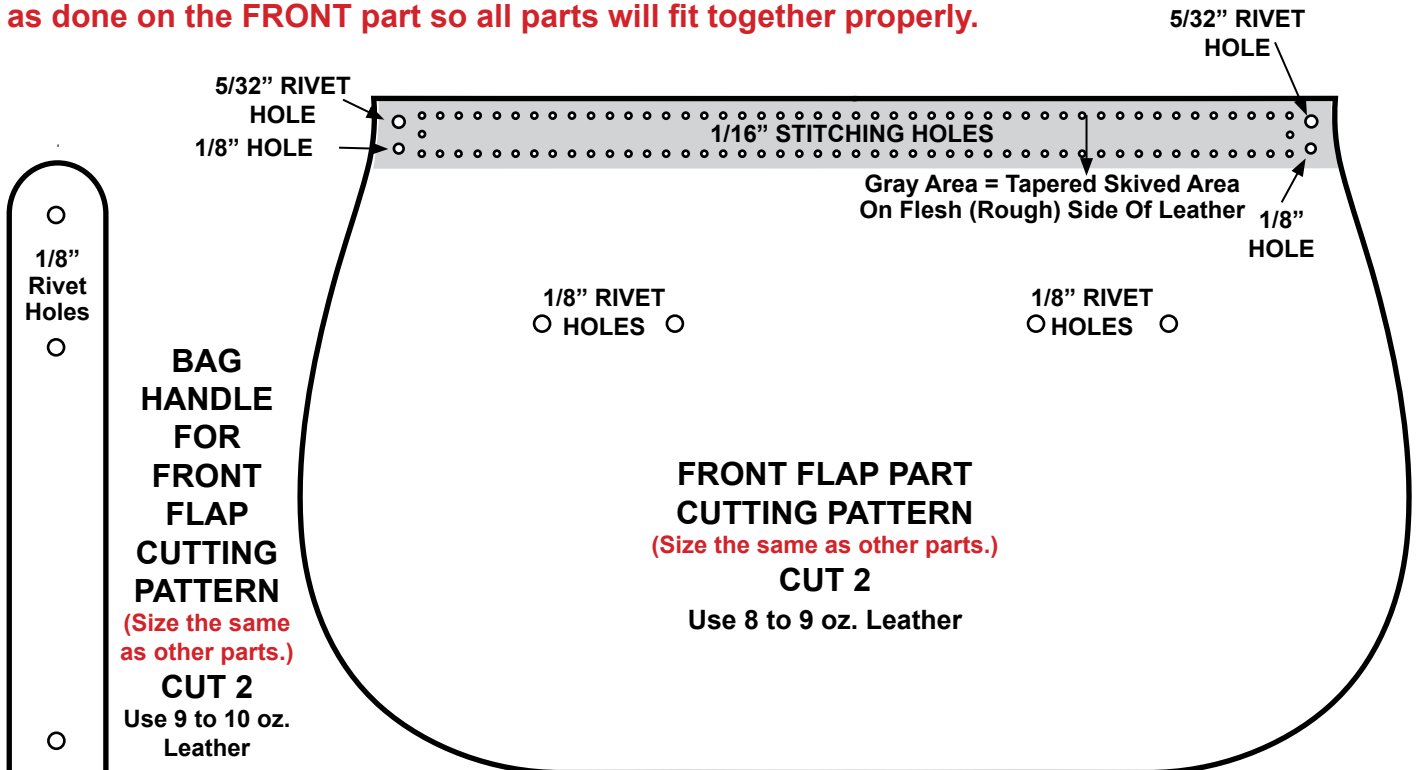

NOTE - USING A SINGLE PIECE CONNECTOR STRAP INSTEAD OF LOWER & UPPER CONNECTOR STRAPS: If you wish to use 1 piece connector straps (for non-removeable bags), position upper connector strap pattern over lower pattern lining up hook and loop area of upper over hook and loop area of lower. Tape patterns together to create 1 connector strap pattern. Cut 1 connector strap out of 8 to 9 oz. leather. Then flop pattern and cut connector strap for other side. Do not cut in turn clasp slits or openings. Turn clasp along with hook and loop fasteners will not be used.

Gray Area = Tapered Skive On Flesh (Rough) Side Of Leather

Punch 1/16" stitching holes where indicated.

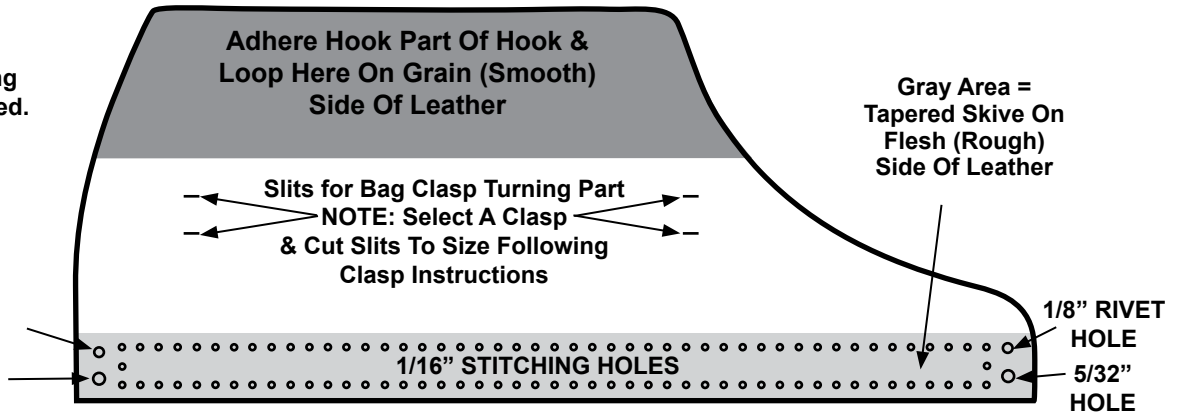

LOWER CONNECTOR STRAP PART CUTTING PATTERN

(Size the same as other parts.)

CUT 1 for Left Bag (Flop Pattern & Cut Another 1 for Right Bag) Use 8 to 9 oz. Leather

Install the turn part of a bag clasp of your choice such as TLF's #11506-00.



1/8" RIVET HOLE
5/32" HOLE

Punch 5/32" holes

BAG BILLET STRAP CUTTING PATTERN

(Size the same as other parts.)

CUT 4

Use 9 to 10 oz. Leather

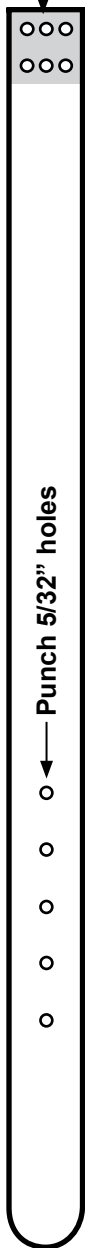

Punch 5/32" lacing holes

TOP CONNECTOR STRAP PART CUTTING PATTERN

(Size the same as other parts.)

CUT 1 for Left Bag (Flop Pattern & Cut Another 1 for Right Bag) Use 8 to 9 oz. Leather

Install eyelet parts of bag clasps of your choice - such as TLF's #11506-00.



Adhere Loop Part Of Hook & Loop Here On Flesh (Rough) Side Of Leather

Slits for Bag Clasp Eyelet Part
NOTE: Select A Clasp & Cut Slits Following Clasp Instructions

NOTE: INSTALL OF ALL DECORATIONS (SPOTS, RIVETS, CONCHOS, ETC.) BEFORE ASSEMBLY.

ASSEMBLY:

Step 1: Install all hardware where indicated on pattern parts.

- Select 4 clip and dee sets and install on both saddle bag back parts with 4 medium rivets (A).



- Install roller buckles onto buckle straps. Then rivet 2 straps to each bag front as shown (B).

- Select clasps (such as #11506-00) and install: Turning part of clasps on both lower connector strap parts & clasp eyelet parts on both top connector strap parts where indicated on patterns, following instructions that come with your desired clasps.



Step 2: Install all hook & loop pieces (C) on lower & top connector strap parts where indicated on patterns using contact cement.

Step 3: Install handle to front flaps using rivets (D).

Step 4: Insert 2 straps under handle between rivets, aligning stitching holes in straps over 10th, 11th and 12th holes in from each side of flap, as shown (E).

Step 5: Place back part under pre-assembled front part with straps inserted under handle, aligning all holes. Place lower connector strap part on top, aligning holes with other parts (E).

Step 6: Stitch back, flap and lower connector strap parts together with 4 yards of thread and needle as follows: From rough side of back, stitch up through first aligned stitching holes in back, flap and lower connector strap leaving 6" of thread on rough side of back to tie off later (E). Stitch in and out through all aligned holes back to starting hole. Turn and stitch back around filling in between previous stitches. At last hole, stitch to inside of bag (rough side of back) and tie off with 6" end. Trim excess close to knot. (Optional knotless ending: At last hole, stitch back through 3 holes to rough side of back. Remove needle and attach to 6" end. Stitch 6" thread end back through 2 holes to rough side of back. Trim both ends close to knot. Tap with mallet to secure.)

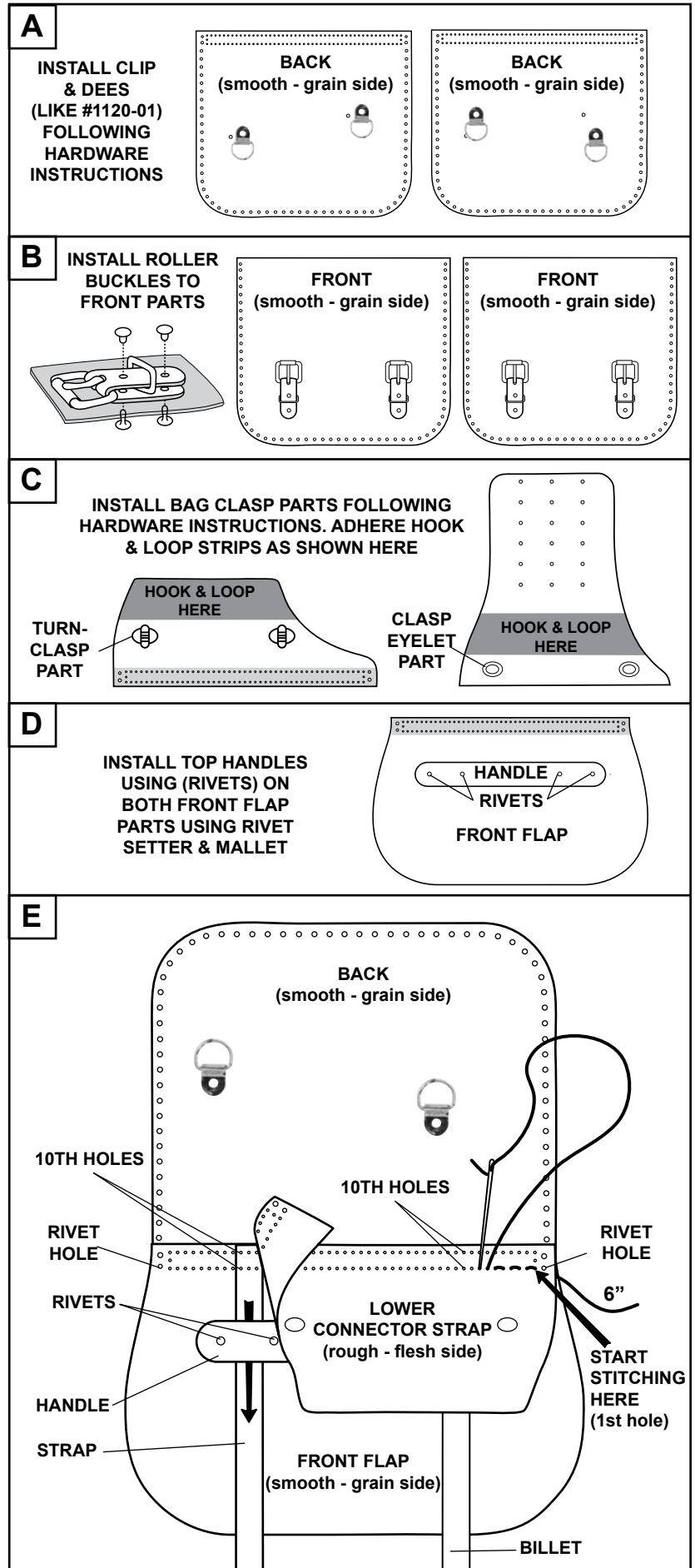

Step 7: Overlap ends of 2 gussets (smooth - grain sides up) aligning lacing holes (F). Trim one end of 18" piece of lace to a point and screw on Jumbo Perma-Lok™ lacing needle. Insert lace between gusset pieces down through second hole in lower gusset piece only, leaving 2" of lace (F Inset). Lace back through 1st hole in both pieces, then back down through second aligned holes (F). Pull lace tight to secure end. Do not allow lace to twist. Continue lacing in and out to last hole. Lace down through last hole, then back through previous hole in one gusset piece only. Pull lace out between gusset pieces to rough side and trim excess.

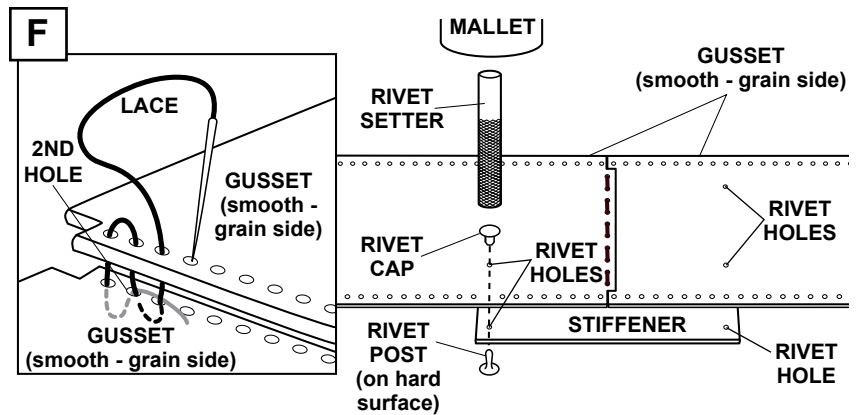

Step 8: Rivet 1 stiffener to gusset assembly, flesh sides together, with 4 large rivets (F).

Step 9: Rivet back assembly to gusset assembly with two large rivets (G).

Step 10: Lace back assembly to gusset with 2 yards of lace as follows: From inside of bag, lace up through second hole (from rivet) in gusset part only, leaving 2" of lace between back and gusset parts (H). Next, lace down through first aligned holes in both parts. Lace back up through second aligned holes in both parts. Continue lacing around back and gusset parts to rivet on other side. At last hole, turn and lace back through previous hole in gusset only to inside of bag. Pull lace tight to secure and trim off excess.

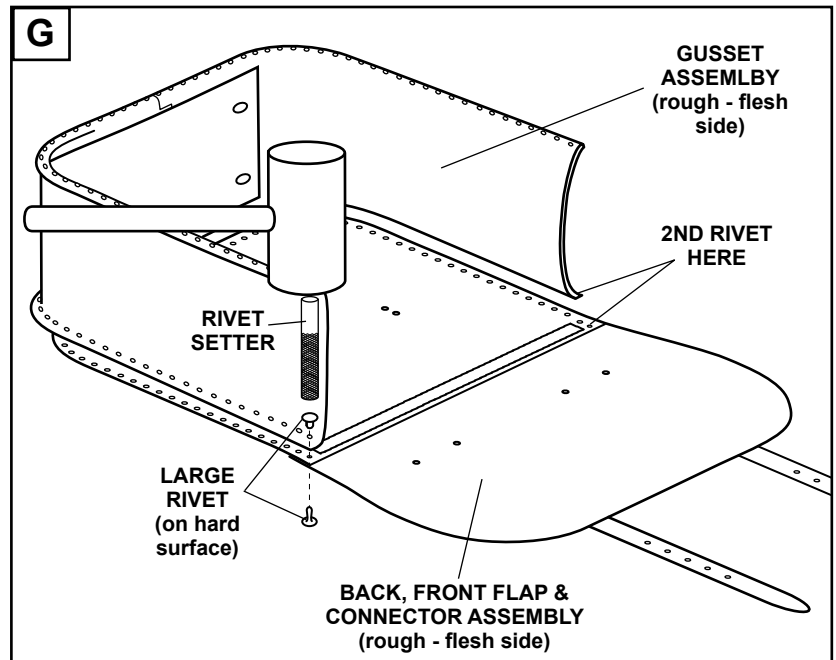

Step 11: Rivet front assembly (rough side facing back assembly) to gusset with large rivets as explained in Step 6 (riveting back assembly to gusset, shown in G).

Step 12: Lace front assembly to gusset as explained in Step 10 (lacing back assembly to gusset, H).

Step 13: Repeat Steps 1 - 9 on second bag.

Step 14: Attach 27" long lace to each dee on backs. Fold lace in half and insert loop through dee. Loop over ends. Pull tight (I).

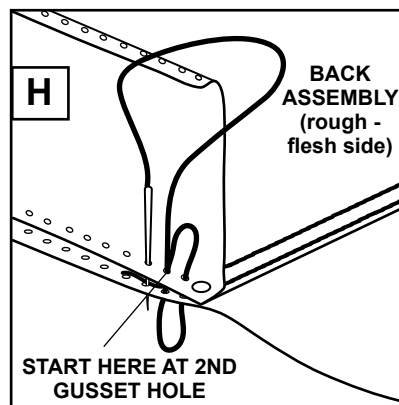

Step 15: Connect removable top connector straps to lower bottom connector straps with pre-attached hook & loop and clasp.

Step 16: Lace adjustable top connector straps together with 1 yard of lace to complete. Overlap and align holes at desired position. Start lacing on grain (smooth side) as shown (J). Trim lace ends to desired length.

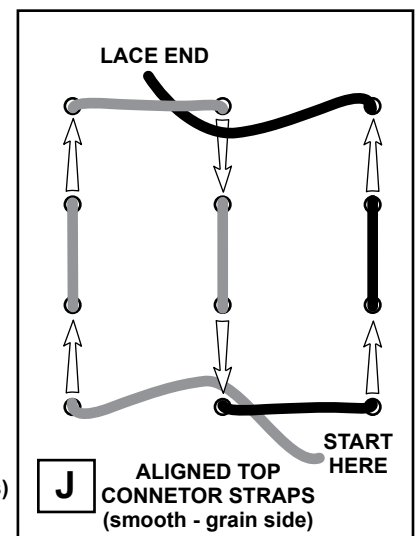
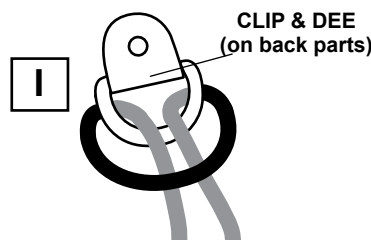

From Tony Laier's Bench:

Motorcycle Saddle Bags

(With Removable Bags)

Each Bag Approx. 12-3/4" Wide x 11" Tall x 6-3/4" Deep



NOTE: Saddle Bags can be sized as explained on front part pattern (at right) or sized smaller or larger. Hardware, straps and some holes may need to be adjusted for alternate sizing.

YOU WILL NEED:

- Bag Fronts, Flaps, Gussets & Connector Strap 8 To 9 Oz. Leather
- Bag Backs, Handles, Billet Straps & Stiffeners 9 To 10 Oz. Leather
- Buckle Straps 6 To 7 Oz. Leather
- 4 Medium Rapid Rivets (#1120-01 Or #1381-12)
- 28 Large Rapid Rivets (#1275-12 Or #1375-12)
- 4 Clips With 3/4" Dees (#1120-01)
- 4 (1") Single Prong Roller Buckles (#1516-02)
- 4 (1") Strap Keeper Formed Loops (#1137-04)
- 4 Bag Clasps (#11506-00)
- 12 Yards 5/32" Latigo Lace
- 8 Yards Waxed Thread & Needles
- 1/16", 1/8" & 5/32" Hole Punches
- 1" Bag (Slot) Punch
- Leather Knife & Skiver Or Safety Beveler
- Adjustable "V" Gouge (#31811-00 Or 8082-00)
- Rivet Setter (#8100-00)
- Jumbo Perma Lok™ Needle (#1193-00)
- 2 Pieces Of Hook & Loop Fastener (each 2" X 9")

CUTTING PATTERNS:

1) Enlarge front part to desired size. Then enlarge remaining pattern parts the same % so all parts will fit together properly.

2) Transfer enlarged patterns to grain side of leather and cut indicated number of parts.

3) Punch all holes where indicated. Hole sizes shown are for the width (255%) sized bags. If yours are different, adjust holes accordingly.

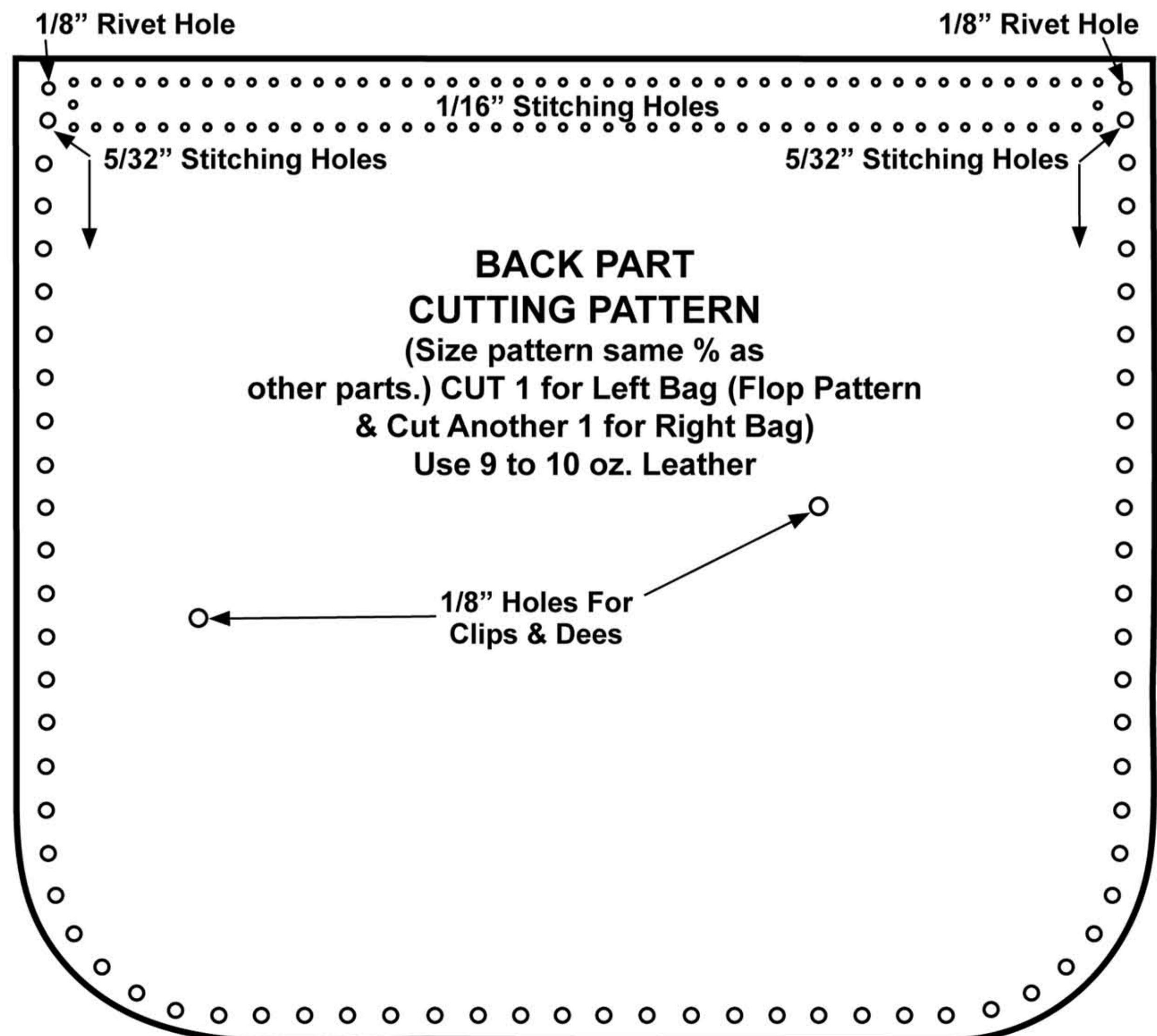
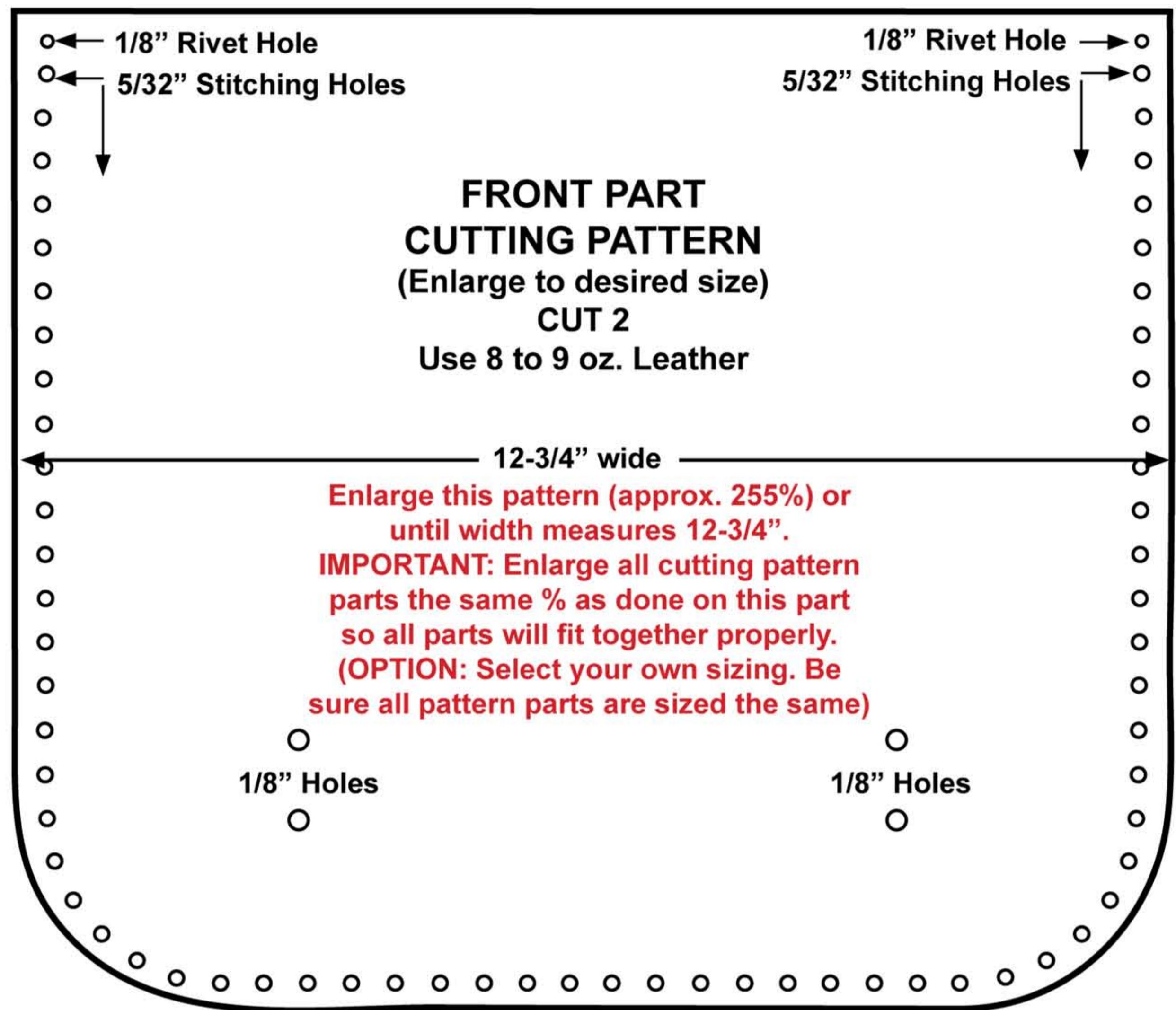



1



From Tony Laier's Best Motorcycle Saddle Bags (With Removable Bags)

Each Bag Approx. 12-3/4" Wide x 11" Tall x 6-3/4"

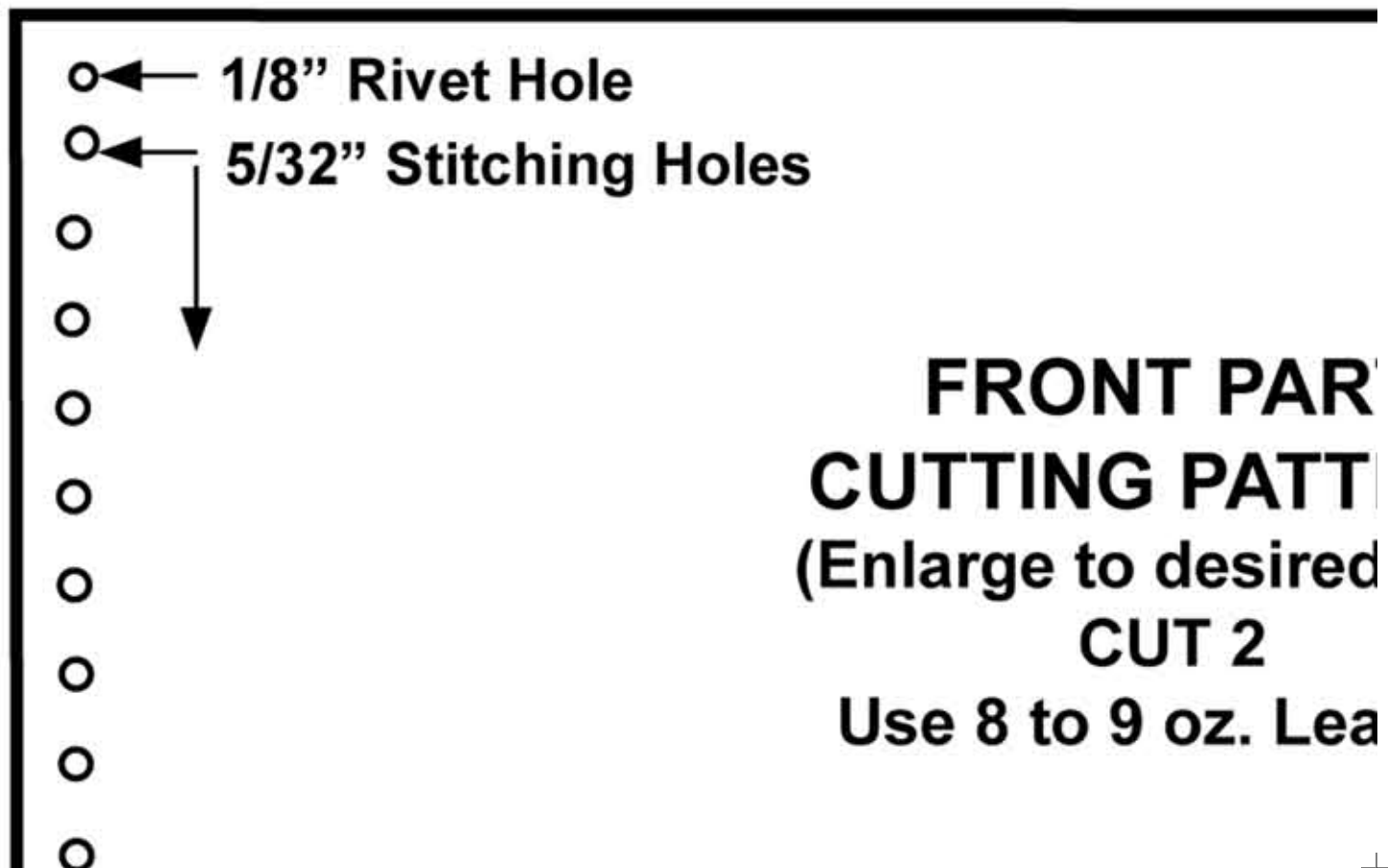

nch:



4" Deep

1/8" Rivet Hole → ○
5/32" Stitching Holes → ○



**T
ERN
(size)**

ther



NOTE: Saddle Bags can be sized as explained on front part pattern (at right) or sized smaller or larger. Hardware, straps and some holes may need to be adjusted for alternate sizing.

YOU WILL NEED:

- Bag Fronts, Flaps, Gussets & Connectors
Strap 8 To 9 Oz. Leather
- Bag Backs, Handles, Billet Straps & Stiffeners 9 To 10 Oz. Leather
- Buckle Straps 6 To 7 Oz. Leather
- 4 Medium Rapid Rivets (#1120-01 Or #1381-12)
- 28 Large Rapid Rivets (#1275-12 Or #1375-12)
- 4 Clips With 3/4" Dees (#1120-01)
- 4 (1") Single Prong Roller Buckles (#1516-02)
- 4 (1") Strap Keeper Formed Loops (#1137-04)
- 4 Bag Clasps (#11506-00)
- 12 Yards 5/32" Latigo Lace

12-3/4" wide

Enlarge this pattern (approx
until width measures
IMPORTANT: Enlarge all cu
parts the same % as done
so all parts will fit together
(OPTION: Select your own
sure all pattern parts are siz

ht)

re

or

1/8" Holes

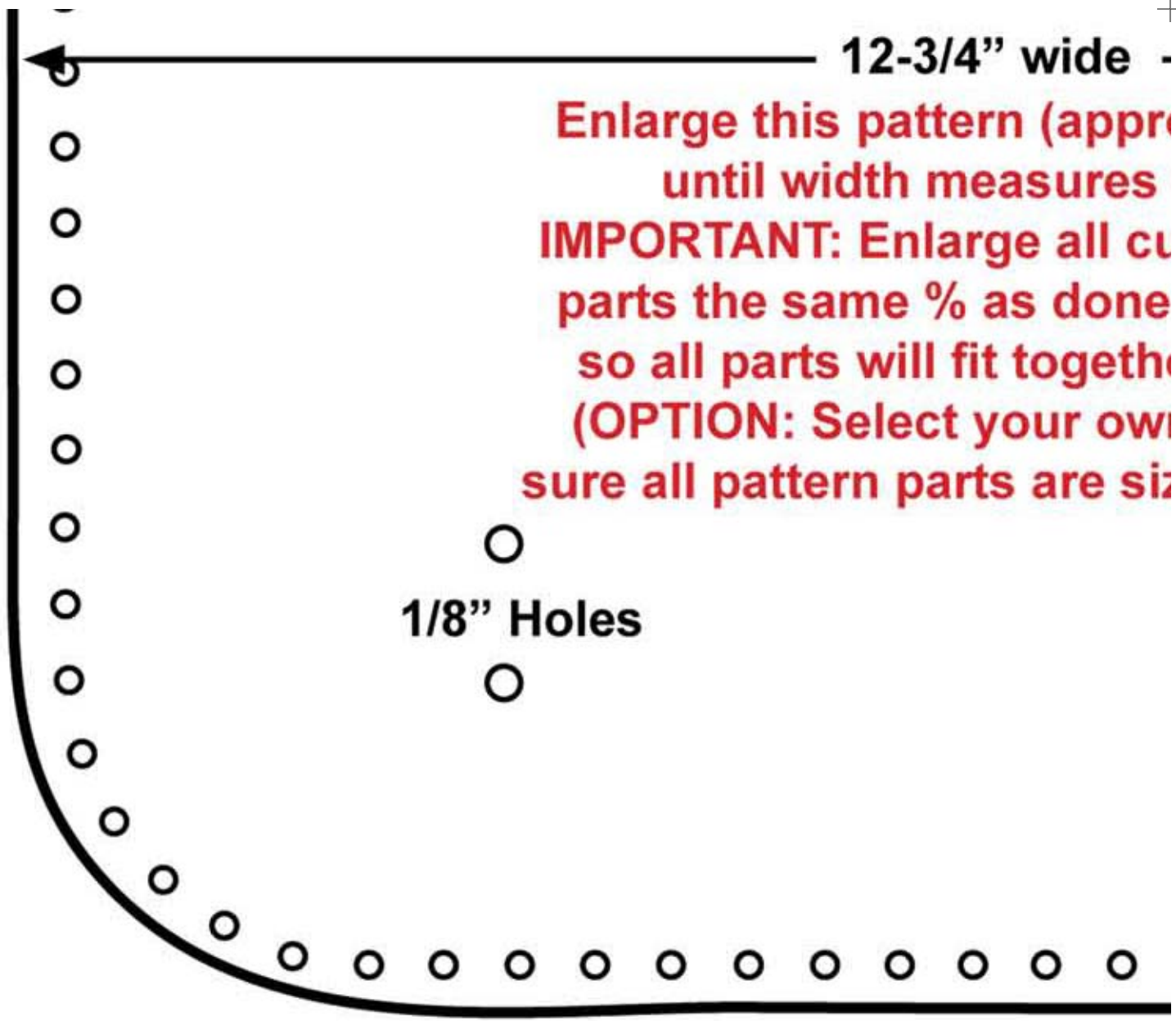

1/8" Rivet Hole

1/16" Stitching Ho

5/32" Stitching Holes



BACK PART
CUTTING PATT
(Size pattern same

ox. 255%) or
12-3/4".
itting pattern
on this part
er properly.
n sizing. Be
zed the same)

○
1/8" Holes
○

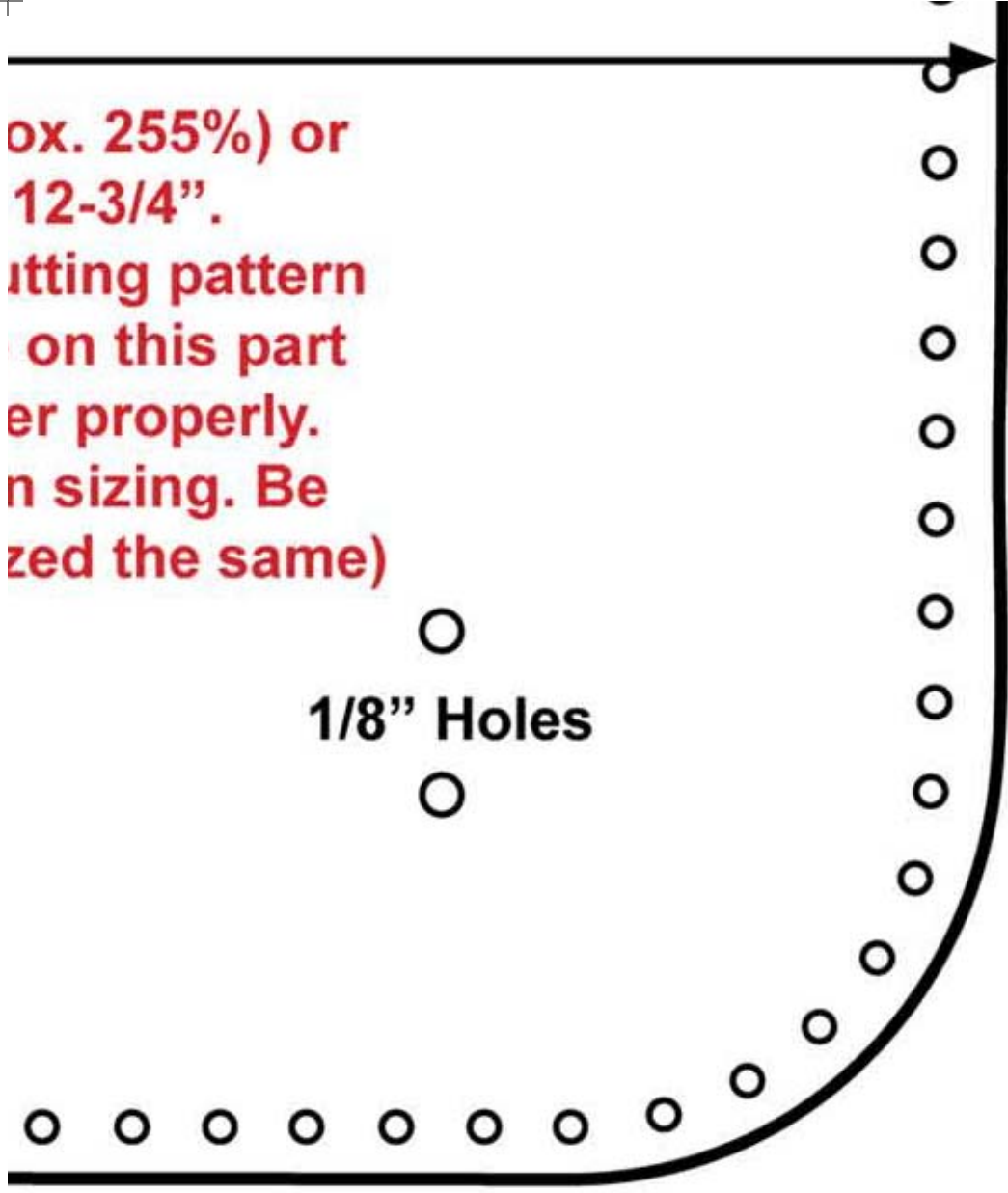

1/8" Rivet Hole



oles

5/32" Stitching Holes

T
ERN

0% as

- 8 Yards Waxed Thread & Needles
- 1/16", 1/8" & 5/32" Hole Punches
- 1" Bag (Slot) Punch
- Leather Knife & Skiver Or Safety Beveler
- Adjustable "V" Gouge (#31811-00 Or 8082-00)
- Rivet Setter (#8100-00)
- Jumbo Perma Lok™ Needle (#1193-00)
- 2 Pieces Of Hook & Loop Fastener (each 2" X 9")

CUTTING PATTERNS:

1) Enlarge front part to desired size. Then enlarge remaining pattern parts the same so all parts will fit together properly.

2) Transfer enlarged patterns to grain side of leather and cut indicated number of parts.

3) Punch all holes where indicated. Hole sizes shown are for the width (255%) sized bags. If yours are different, adjust holes accordingly.

(Size pattern same
other parts.) CUT 1 for Left E
& Cut Another 1 for R
Use 9 to 10 oz. Le

er

h

%

e of

izes

s. If

gly.

1/8" Holes For
Clips & Dees

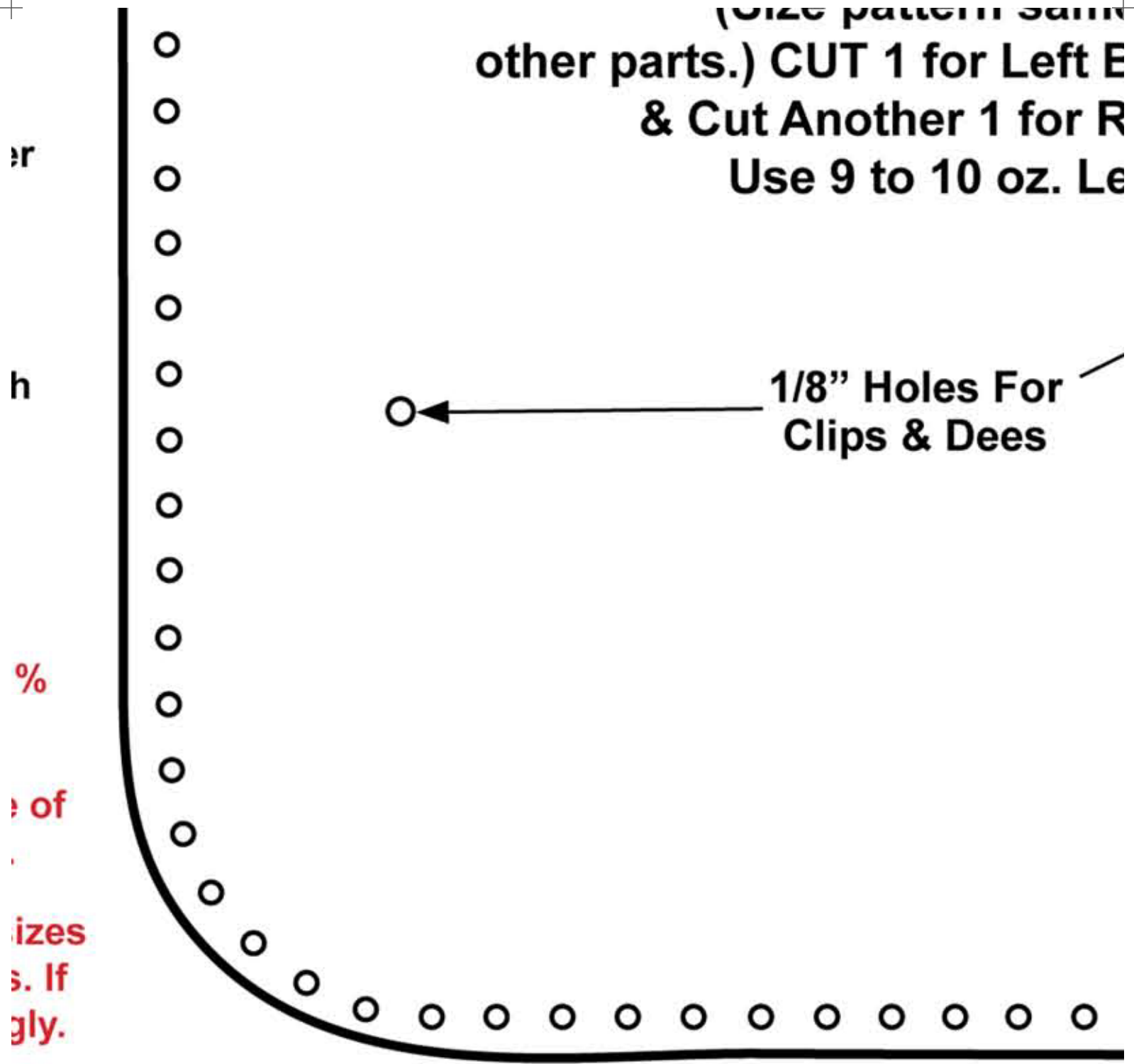

5 70 23

Bag (Flop Pattern
Right Bag)
Leather

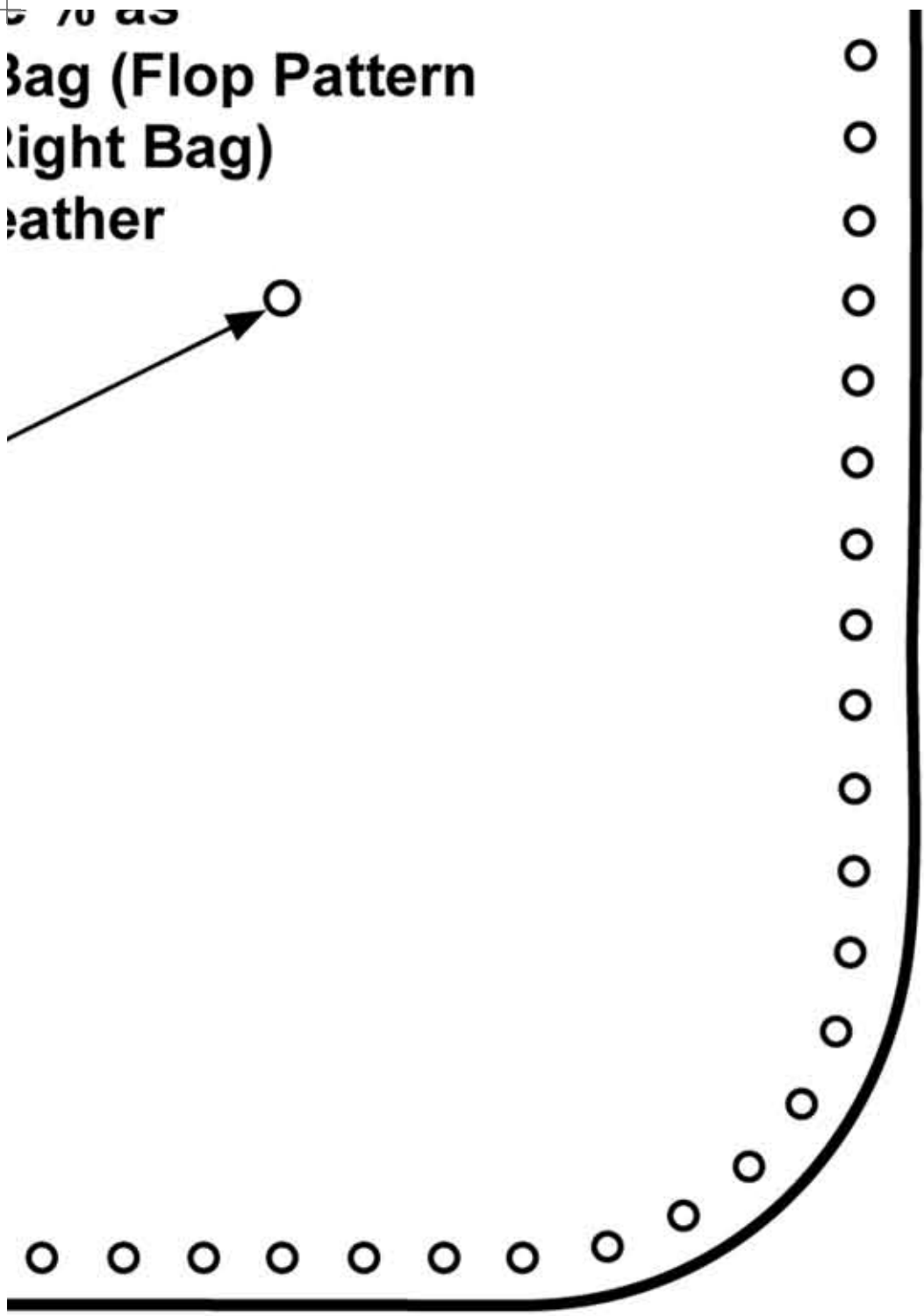

IMPORTANT: Enlarge all cutting pattern parts the same % as done on the FRONT part so all parts will fit together properly.

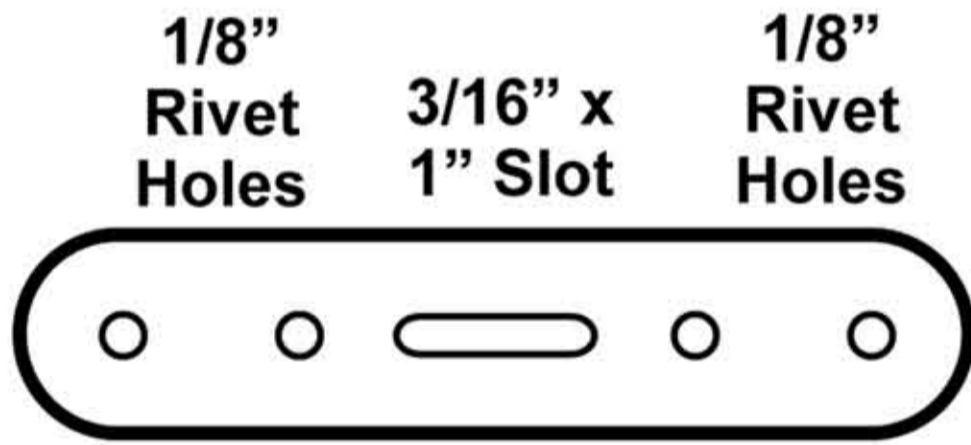
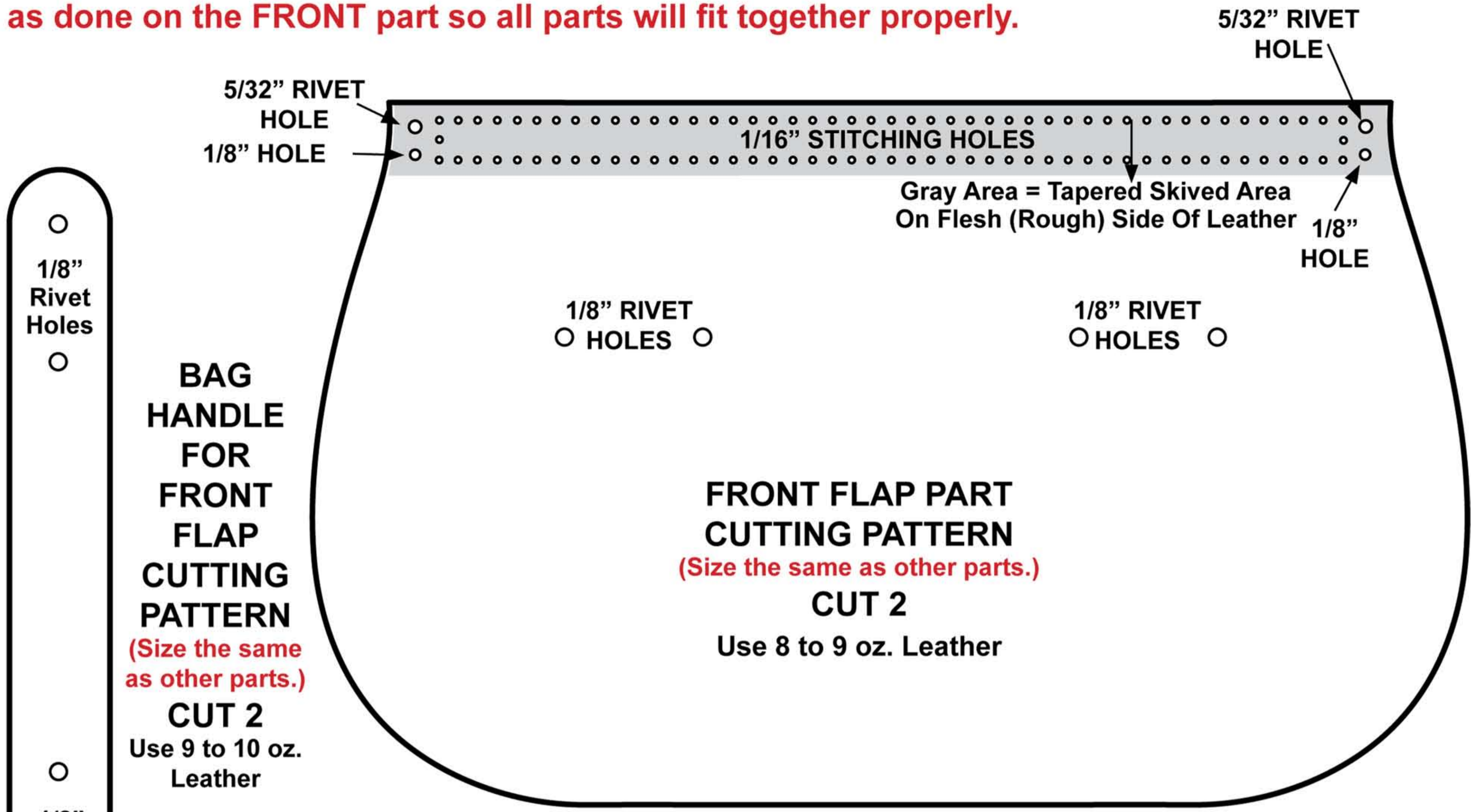

BUCKLE STRAP FOR FRONT PART CUTTING PATTERN
(Size the same as other parts.)
CUT 4
 Use 6 to 7 oz. Leather

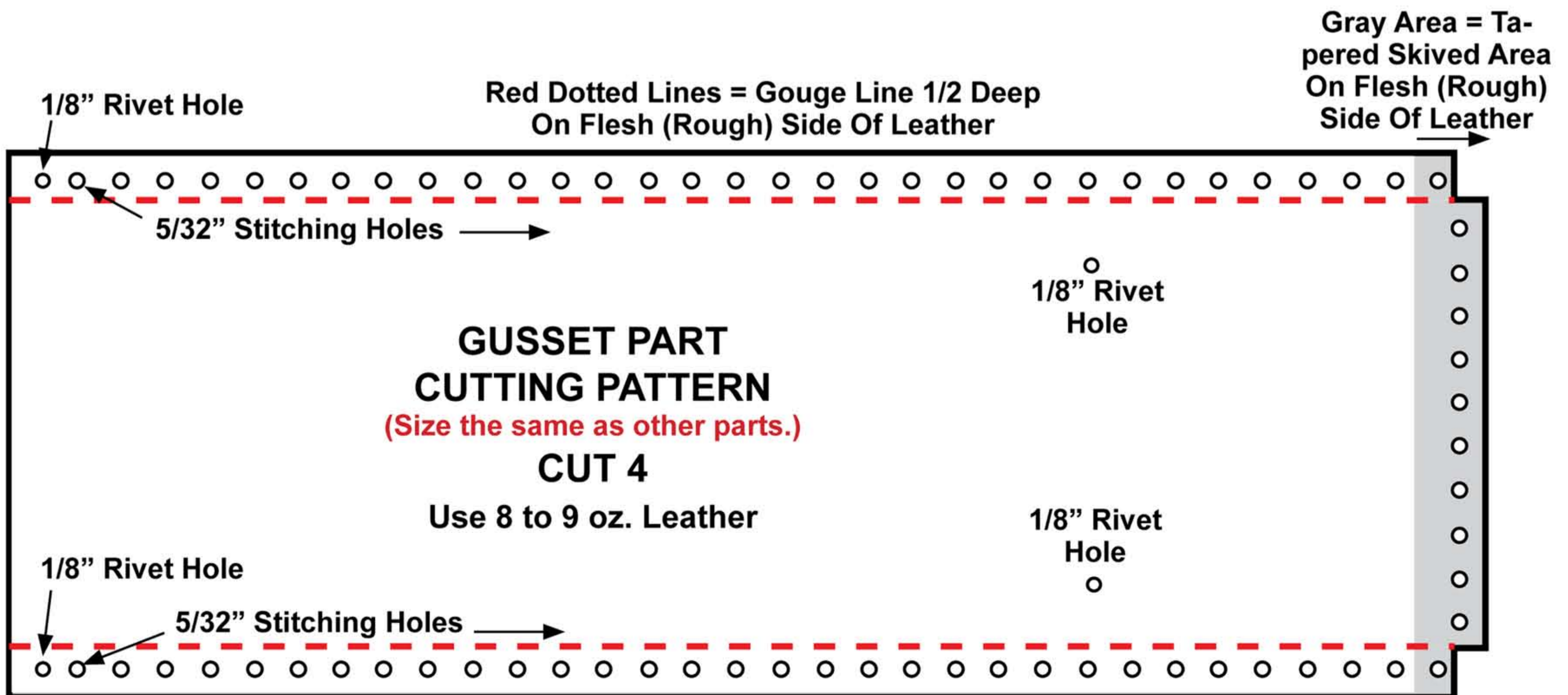

IMPORTANT: Enlarge all cutting pattern parts as done on the FRONT part so all parts will fit

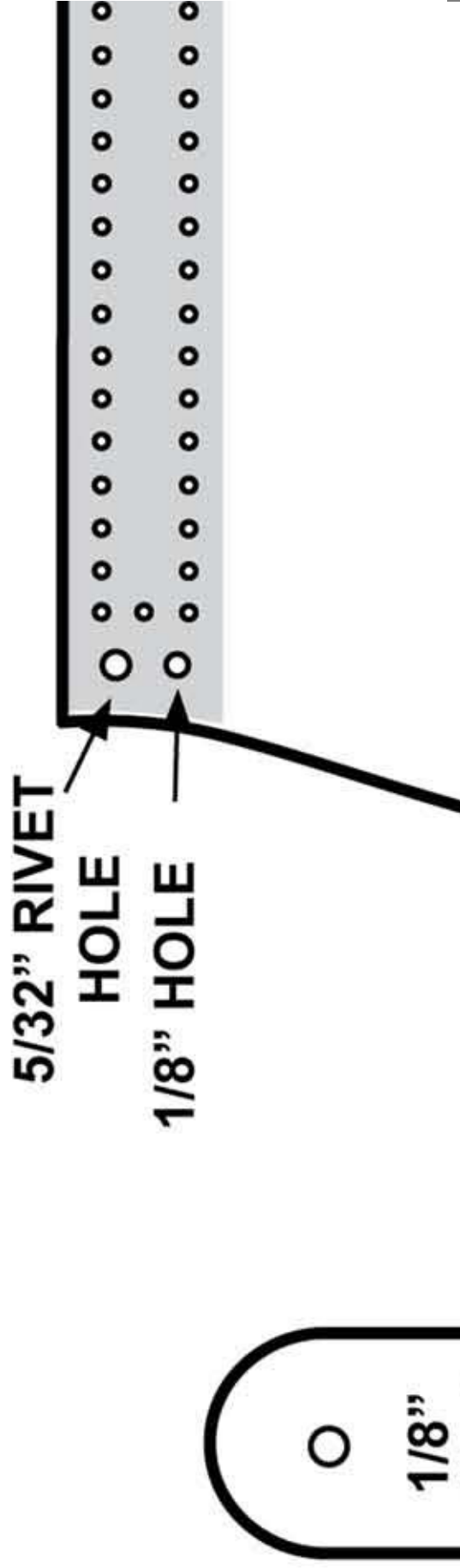

the same %
t together properly.



Rivet
Holes



**BAG
HANDLE
FOR
FRONT
FLAP
CUTTING
PATTERN**

**(Size the same
as other parts.)**

CUT 2

**Use 9 to 10 oz.
Leather**

**1/8" RIVET
HOLES**

**F
C
(Siz**

**1/8"
Rivet
Holes**

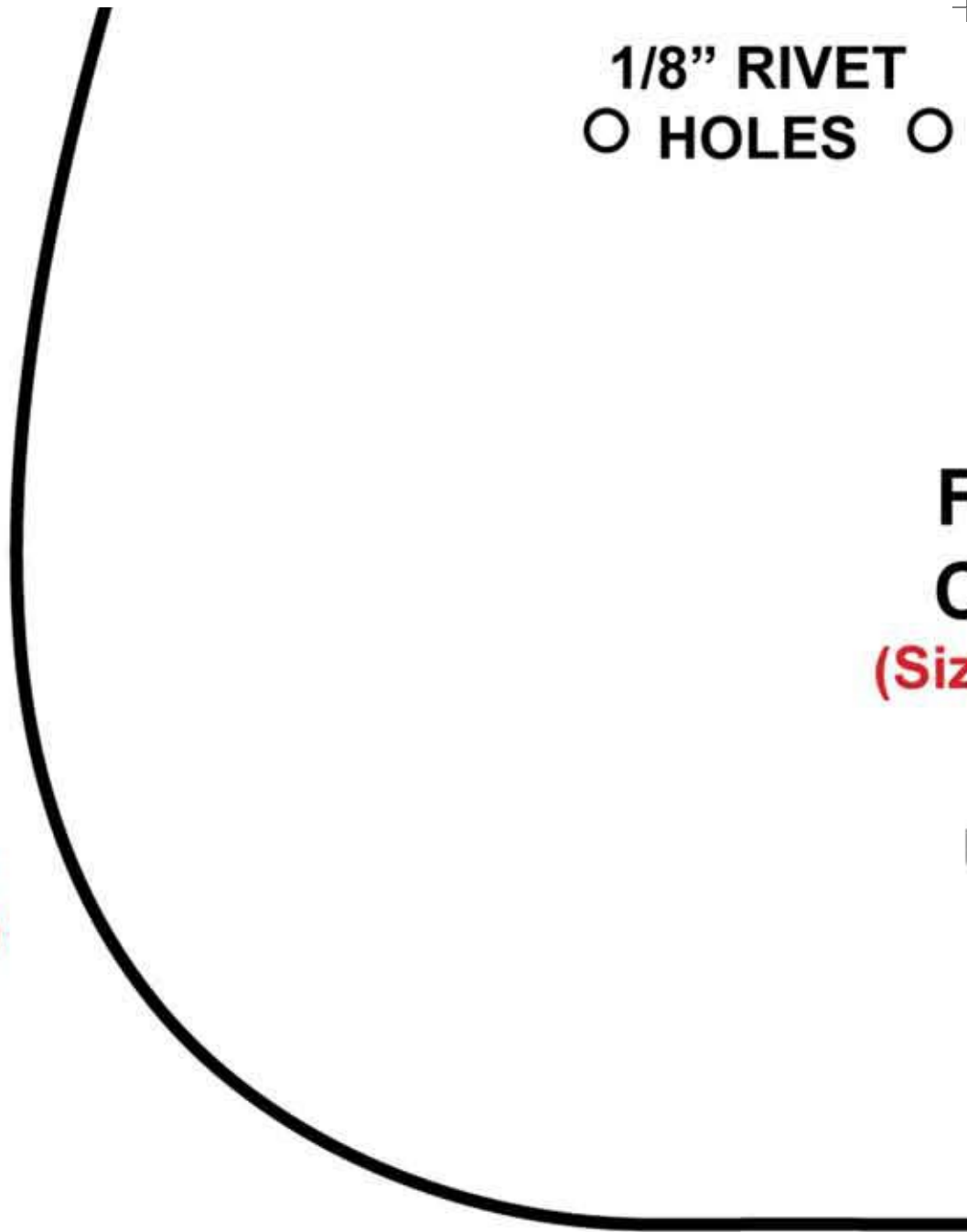

1/8" RIVET
○ HOLES ○

**FRONT FLAP PART
CUTTING PATTERN**
(be the same as other parts.)

CUT 2

Use 8 to 9 oz. Leather

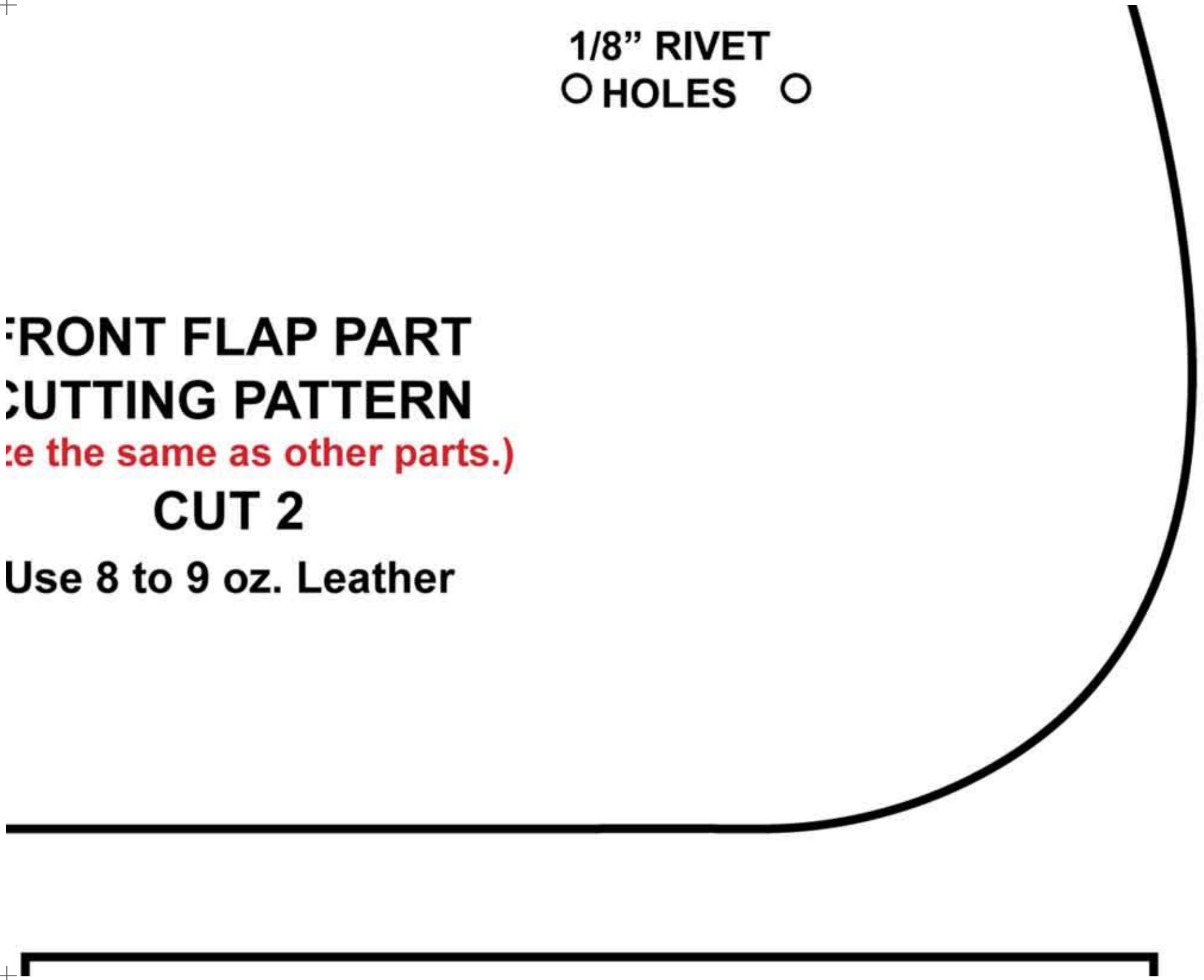



1/8"
Rivet
Holes

3/16" x
1" Slot

1/8"
Rivet
Holes



BUCKLE STRAP FOR FRONT PART CUTTING PATTERN

(Size the same as other parts.)

CUT 4

Use 6 to 7 oz. Leather

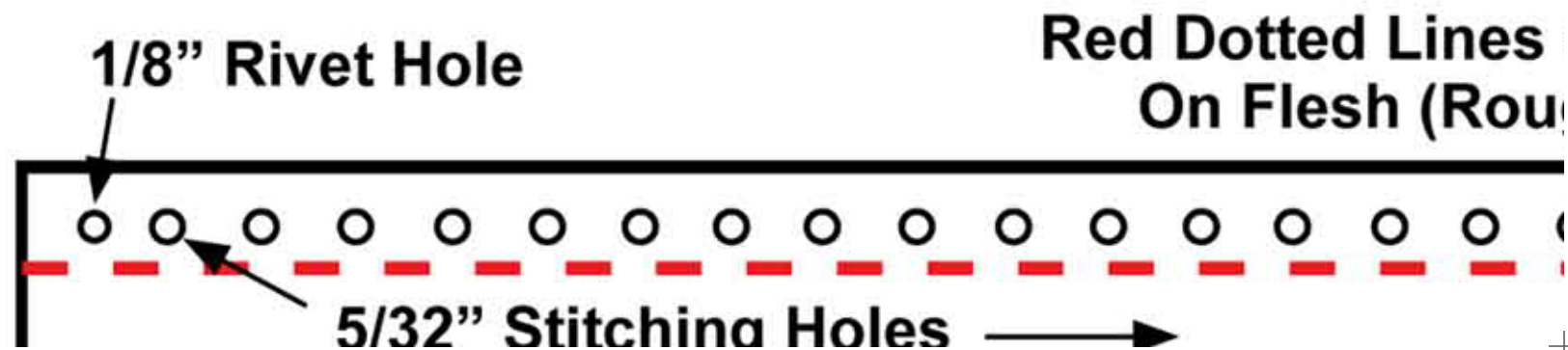

○
1/8"
Rivet
Hole

○
1/8"
Rivet
Hole

BOTTOM STIFFENER PART CUTTING PATTERN

(Size the same a other parts.)

CUT 2

Use 9 to 10 oz. Leather

1/8"
○ Rivet
Hole

1/8"
Rivet ○
Hole

Gray Area = Ta-
pered Skived Area
On Flesh (Rough)
Side Of Leather

= Gouge Line 1/2 Deep
(gh) Side Of Leather

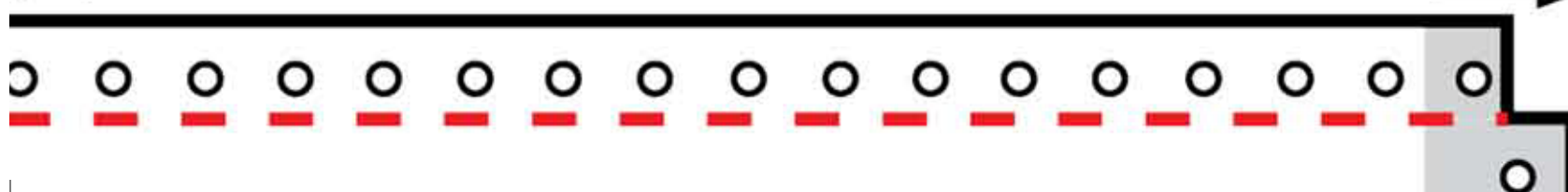

**GUSSET PART
CUTTING PATTERN**

(Size the same as other p

CUT 4

Use 8 to 9 oz. Leather

1/8" Rivet Hole



5/32" Stitching Holes



○
1/8" Rivet
Hole

2N
arts.)

er

1/8" Rivet
Hole
○



NOTE - USING A SINGLE PIECE CONNECTOR STRAP INSTEAD OF LOWER & UPPER CONNECTOR STRAPS: If you wish to use 1 piece connector straps (for non-removeable bags), position upper connector strap pattern over lower pattern lining up hook and loop area of upper over hook and loop area of lower. Tape patterns together to create 1 connector strap pattern. Cut 1 connector strap out of 8 to 9 oz. leather. Then flop pattern and cut connector strap for other side. Do not cut in turn clasp slits or openings. Turn clasp along with hook and loop fasteners will not be used.

Gray Area = Tapered Skive On Flesh (Rough) Side Of Leather

Punch 1/16" stitching holes where indicated.

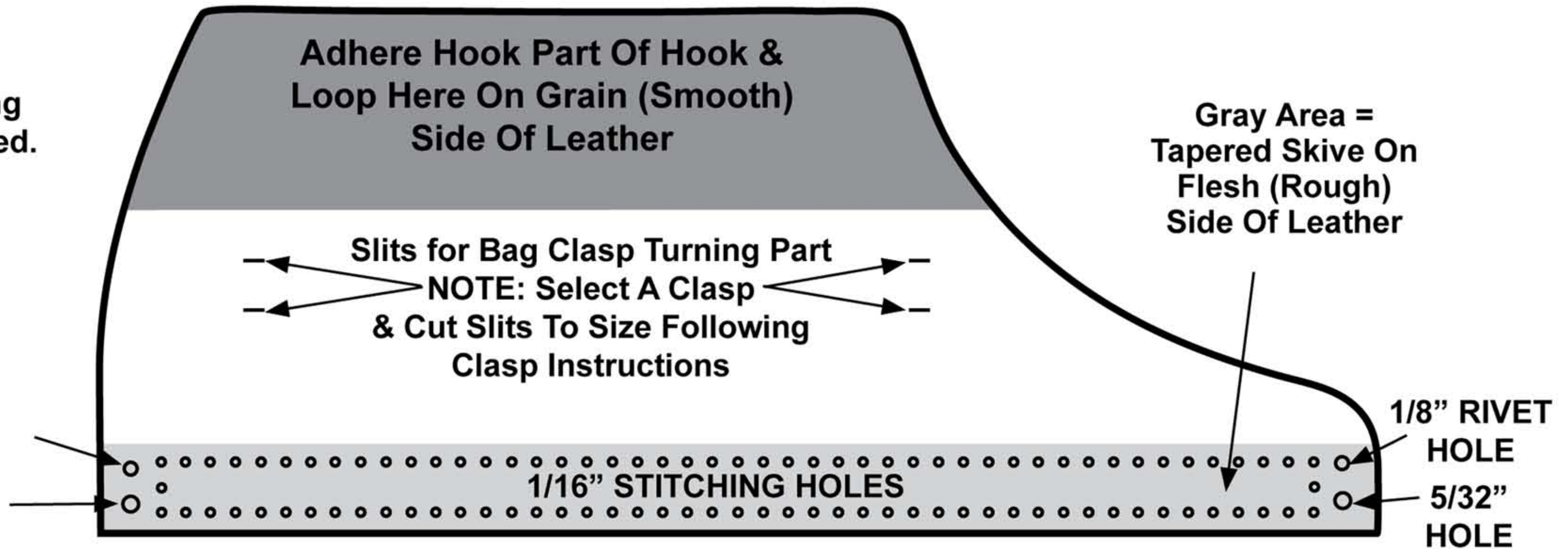

LOWER CONNECTOR STRAP PART CUTTING PATTERN

(Size the same as other parts.)

CUT 1 for Left Bag (Flop Pattern & Cut Another 1 for Right Bag) Use 8 to 9 oz. Leather

Install the turn part of a bag clasp of your choice such as TLF's #11506-00.



1/8" RIVET HOLE
5/32" HOLE

Punch 5/32" holes

BAG BILLET STRAP CUTTING PATTERN

(Size the same as other parts.)

CUT 4

Use 9 to 10 oz. Leather

Punch 5/32" lacing holes

TOP CONNECTOR STRAP PART CUTTING PATTERN

(Size the same as other parts.)

CUT 1 for Left Bag (Flop Pattern & Cut Another 1 for Right Bag) Use 8 to 9 oz. Leather

Install eyelet parts of bag clasps of your choice - such as TLF's #11506-00.

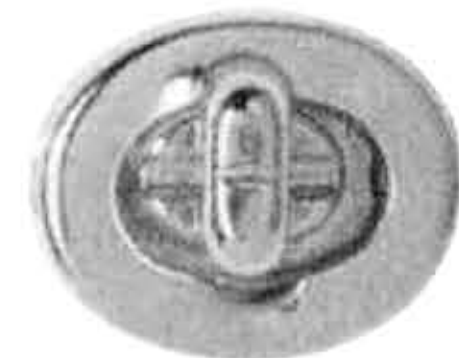

Adhere Loop Part Of Hook & Loop Here On Flesh (Rough) Side Of Leather

Slits for Bag Clasp Eyelet Part
NOTE: Select A Clasp & Cut Slits Following Clasp Instructions

NC
ST
co
are
of
slit

**Gray Area = Tapered
Skive On Flesh
(Rough) Side Of
Leather**

**Punch 1/16" stitching
holes where indicated.**

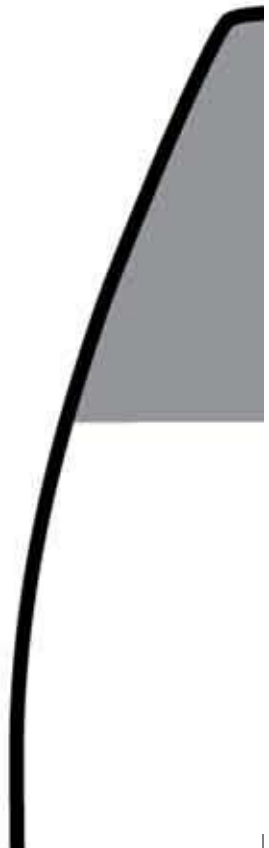
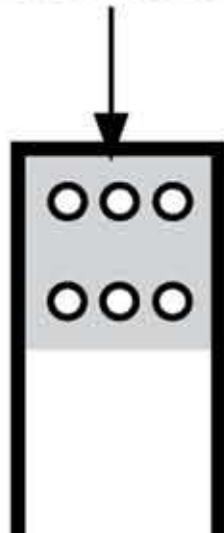

NOTE - USING A SINGLE PIECE CONNECTOR STRAP INSTEAD OF TWO STRAPS: If you wish to use 1 piece connector straps (for no connector strap pattern over lower pattern lining up hook and loop area of lower. Tape patterns together to create 1 connector strap from 8 to 9 oz. leather. Then flop pattern and cut connector straps or openings. Turn clasp along with hook and loop fastener.

Adhere Hook Part Of Hook & Loop Here On Grain (Smooth) Side Of Leather

Slits for Bag Clasp Turning Part
NOTE: Select A Clasp & Cut Slits To Size Following Clasp Instructions

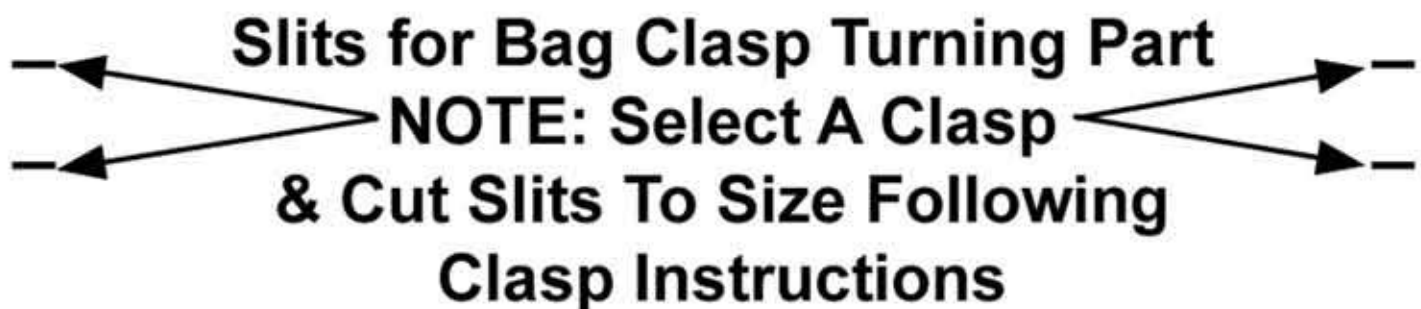

HEAD OF LOWER & UPPER CONNECTOR
*(non-removeable bags), position upper
and loop area of upper over hook and loop
strap pattern. Cut 1 connector strap out
ap for other side. Do not cut in turn clasp
eners will not be used.*

**Gray Area =
Tapered Skive On
Flesh (Rough)
Side Of Leather**



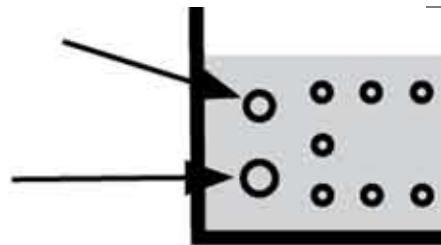

**1/8" RIVET
HOLE
5/32"
HOLE**

← Punch 5/32" holes

**BAG BILLET
STRAP
CUTTING
PATTERN**
**(Size the same
as other parts)**

1/16" STITCHING HOLES

LOWER CONNECTOR STRAP CUTTING PATTERN

(Size the same as other parts.)

CUT 1 for Left Bag (Flop Pattern &
Cut Another 1 for Right Bag) Use 8 to 9 oz

Install the turn part of a
bag clasp of your choice
such as TLF's #11506-00.



Punch 5/32" lacing holes

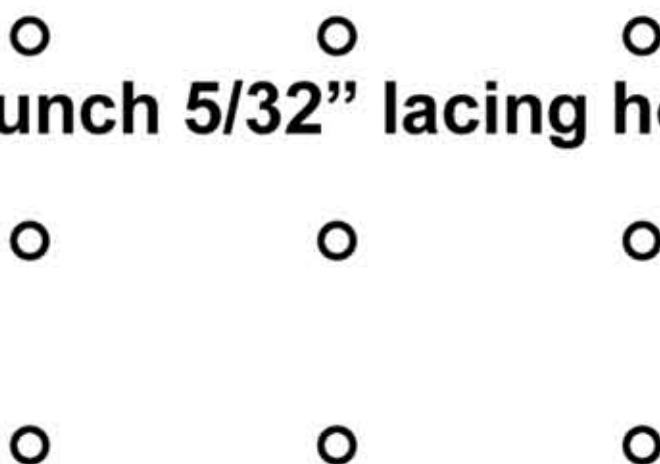

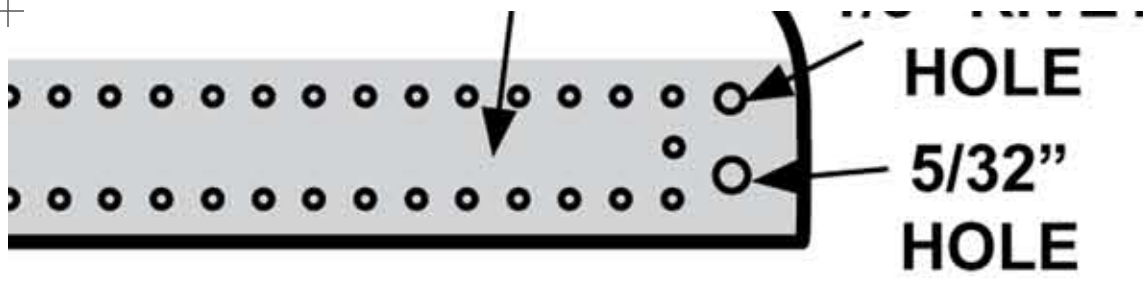

PART

2
Leather



**TOP CONNECTOR
STRAP PART
CUTTING PATTERN**
(Size the same

as other parts.

CUT 4

Use 9 to 10 oz. Leather

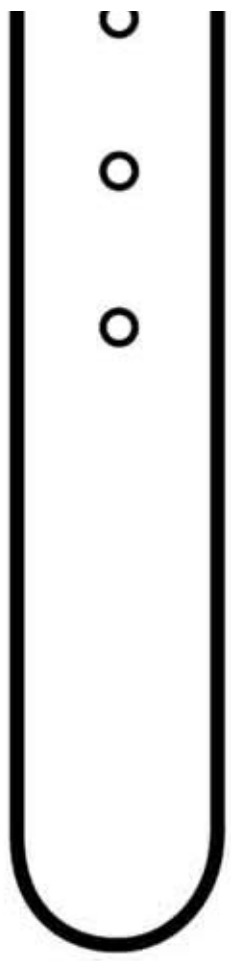

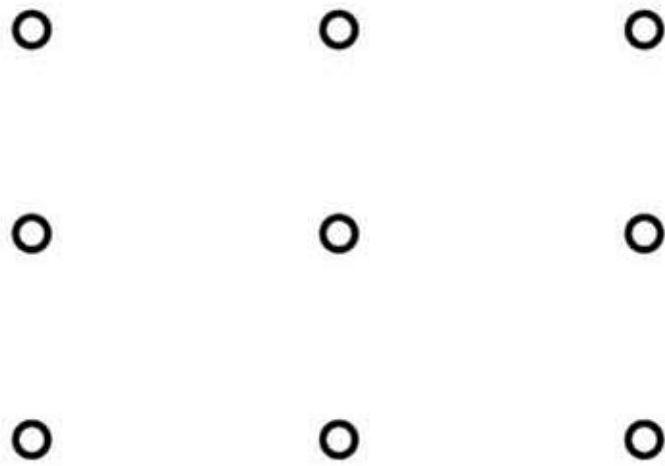

**Adhere Loop Part Of Hook & Loop
Here On Flesh (Rough) Side
Of Leather**

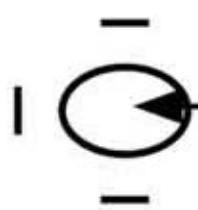

Slits for Bag Clasp Eyelet Part

**NOTE: Select A Clasp & Cut
Slits Following Clasp Instructions**

as other parts.)

**CUT 1 for Left Bag
(Flop Pattern & Cut
Another 1 for Right Bag)
Use 8 to 9 oz. Leather**

**Install eyelet parts of bag clasps
of your choice - such as
TLF's #11506-00.**





Digital Downloads

This PDF package has been put together to give you options when it comes to printing. Some PDF file downloads may contain some documents larger than an 8-1/2" x 11" image. Pages and patterns that are larger than 8½x11 have been provided in two formats:

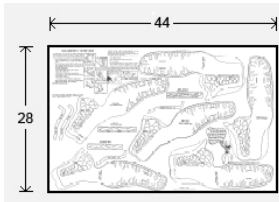

Full Size: If you would like to have a full size print out, take the full size pages to your local print shop and they can print it for you.

Tiled: The tiled pages give you the option of printing the larger patterns at home. You print the tiled pages and then assemble them to make the larger patterns.

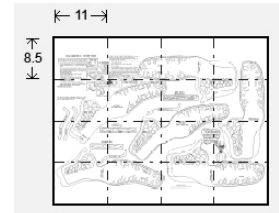

Pattern PDF files are typically laid out as follows: Cover (if applicable), instructions sheets (if applicable), pattern 1 – full sized, pattern 1 – tiled, pattern 2 – full sized, pattern 2 – tiled, pattern 3 – full sized, pattern 3 – tiled. ...Etc.

Doodle Page PDF files are typically laid out as follows: Front – full sized, front – tiled, back – full sized, back – tiled (Some Doodle Pages do not have backs).

eBook PDF files contain 1 (one) full eBook. All pages in the PDF are full sized. This means that you may have to take the PDF to a print shop for certain oversized books if your home printer cannot print the larger pages.

Craftaid PDF files contain 1 (one) full Craftaid pattern or Craftaid pattern pack that has been converted into a tracing pattern. All pages in the PDF are full sized. This means that you may have to take the PDF to a print shop for certain oversized Craftaid patterns if your home printer cannot print the larger pages. **NOTE: These digitized patterns do not include any of the physical plastic templates (Craftaids) that may be mentioned, nor does the purchase of this PDF file imply a promise to receive any physical plastic templates (Craftaids).**

NOTE: Digital kit patterns do not include any kit parts that they may reference.

Please note: When printing on a home printer, use the settings seen on the image to the right in the Page Handling area of the Adobe Reader print dialogue box. If your printer is cutting edges off, set "Page Scaling" to "Shrink to Printable Area". This will, however, decrease the size of the pattern a very small amount.

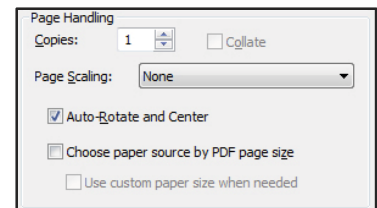

NOTE: Some patterns may reference tools, and other items no longer available.

NOTE: You may take this PDF file to your local print shop to have the full-size pages printed for your own personal use.

This premium has been published by Tandy Leather Factory, 1900 South East Loop 820, Ft. Worth, TX 76140. Copyright © 2011 by Tandy Leather Factory, all rights reserved. The contents of this publication may not be reproduced either in whole or in part without the consent of the copyright owner.

Please respect the copyright by not forwarding or distributing this document.