

Vintage Pattern Series

Satchel Bag Pattern #4370



Finished size 7"x12"x6"



LeathercraftLibrary.com
DIGITAL MEDIA FOR LEATHERCRAFTERS



Digital Downloads

This PDF package has been put together to give you options when it comes to printing. Some PDF file downloads may contain some documents larger than an 8-1/2" x 11" image. Pages and patterns that are larger than 8½x11 have been provided in two formats:

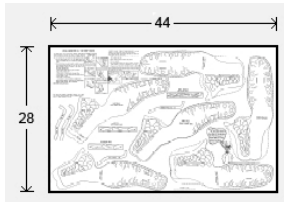

Full Size: If you would like to have a full size print out, take the full size pages to your local print shop and they can print it for you.

Tiled: The tiled pages give you the option of printing the larger patterns at home. You print the tiled pages and then assemble them to make the larger patterns.

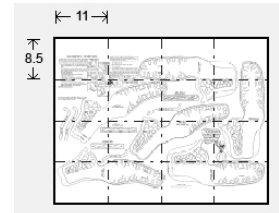

Pattern PDF files are typically laid out as follows: Cover (if applicable), instructions sheets (if applicable), pattern 1 – full sized, pattern 1 – tiled, pattern 2 – full sized, pattern 2 – tiled, pattern 3 – full sized, pattern 3 – tiled. ...Etc.

Doodle Page PDF files are typically laid out as follows: Front – full sized, front – tiled, back – full sized, back – tiled (Some Doodle Pages do not have backs).

eBook PDF files contain 1 (one) full eBook. All pages in the PDF are full sized. This means that you may have to take the PDF to a print shop for certain oversized books if your home printer cannot print the larger pages.

Craftaid PDF files contain 1 (one) full Craftaid pattern or Craftaid pattern pack that has been converted into a tracing pattern. All pages in the PDF are full sized. This means that you may have to take the PDF to a print shop for certain oversized Craftaid patterns if your home printer cannot print the larger pages. **NOTE: These digitized patterns do not include any of the physical plastic templates (Craftaids) that may be mentioned, nor does the purchase of this PDF file imply a promise to receive any physical plastic templates (Craftaids).**

NOTE: Digital kit patterns do not include any kit parts that they may reference.

Please note: When printing on a home printer, use the settings seen on the image to the right in the Page Handling area of the Adobe Reader print dialogue box. If your printer is cutting edges off, set "Page Scaling" to "Shrink to Printable Area". This will, however, decrease the size of the pattern a very small amount.

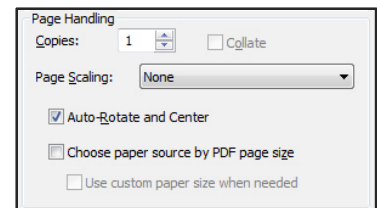

NOTE: Some patterns may reference tools, and other items no longer available.

NOTE: You may take this PDF file to your local print shop to have the full-size pages printed for your own personal use.

This premium has been published by Tandy Leather Factory, 1900 South East Loop 820, Ft. Worth, TX 76140. Copyright © 2011 by Tandy Leather Factory, all rights reserved. The contents of this publication may not be reproduced either in whole or in part without the consent of the copyright owner.

Please respect the copyright by not forwarding or distributing this document.

SATCHEL BAG KIT

STOCK NO. 4370

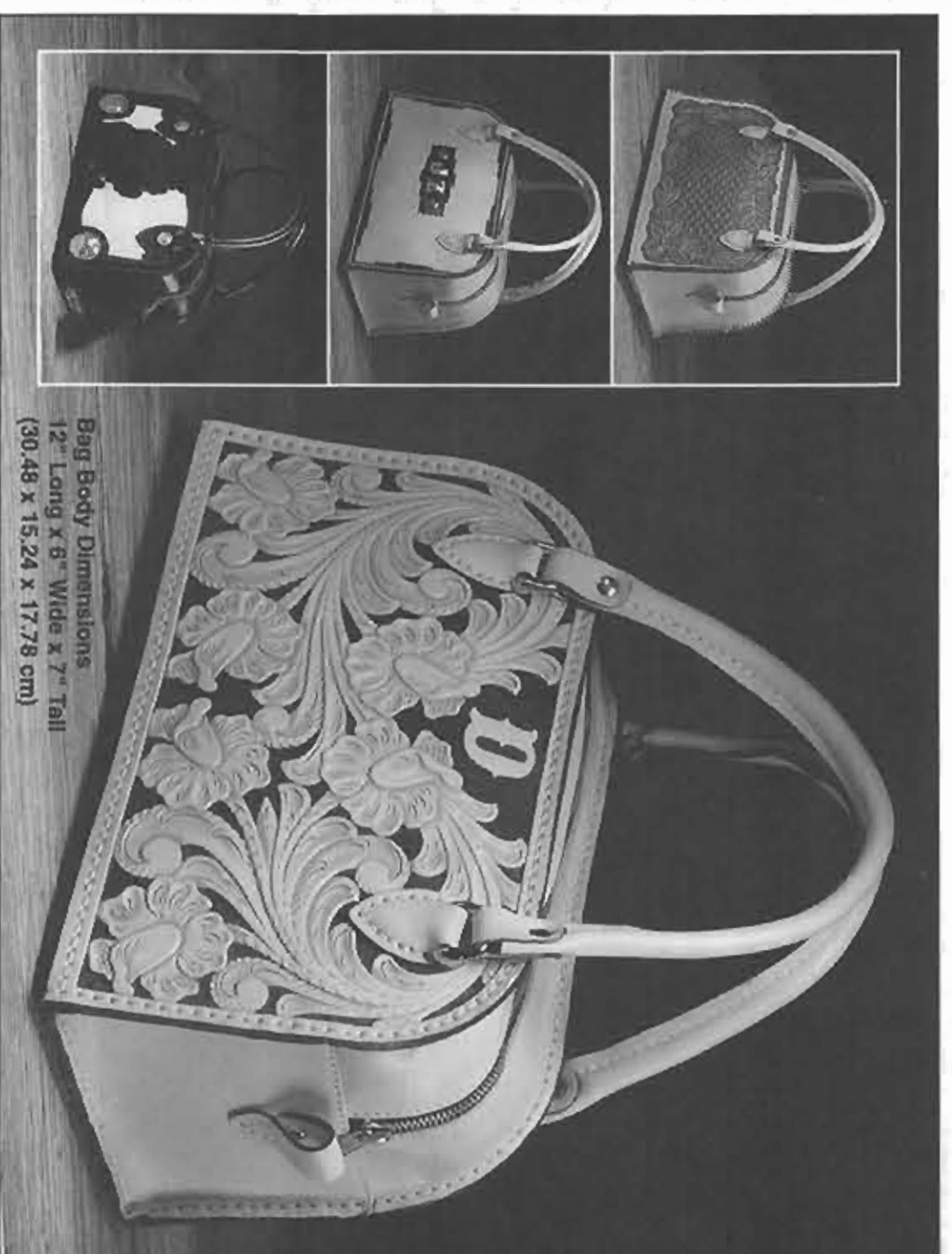

Bag Body Dimensions:
12" Long x 5" Wide x 7" Tall
(30.48 x 12.7 x 17.78 cm)

- KIT CONTAINS:**
- Pre-Cut, Pre-Punched Leather Parts
 - Pre-Sewn Zipper Gusset Assembly
 - Rolled Handles - Ready To Attach
 - Hardware - Including 4 Knobby Rivets For Feet
 - Natural Color Wax Thread and Needles
 - Complete Assembly Instructions - Includes Optional Lining and Pocket Instructions
 - Design Suggestions
- YOU WILL NEED:**
- Bone Folder, No. 8110
 - Bone Folder, No. 8116
 - Size 3 Bone-Eye Edge Beveler, No. 8076
 - Craftsmen® Cement
- OPTIONAL:**
- 15 1/2 yds. Leather Lace and Lacing Needle for Double Loop Lacing
 - 2 to 2 1/2 oz. Lining Leather and 1/8" and 3/64" Punches, if Bag is to be Lined
 - Skiving Knife
 - Chisels for Decorations
 - Hair Call or other material for inserts
 - 8 yds. additional Waxed Thread for inserts
 - Horse Hair for Zipper Pull Tassels
- Distributed by
Tandy Leather Co.
For Worth, Texas 78140

KIT PARTS

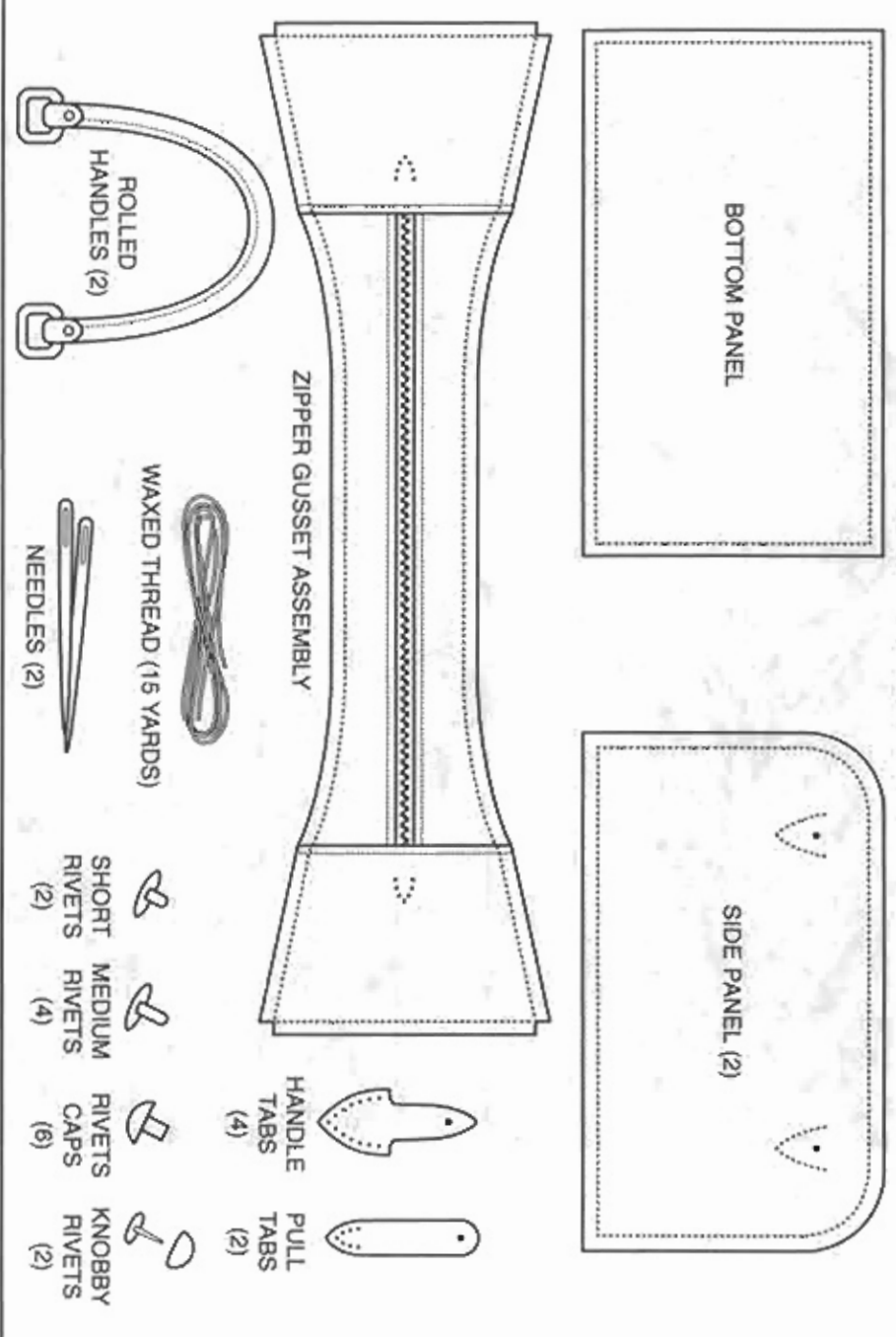

RAPID RIVET SETTING INSTRUCTIONS

For permanently finishing leather, using the pre-punched hole, push post through leather. Place on metal leveling surface. Place cap on post. Using concave face of setter, strike sharply with mallet until rivet is set.

BURNISHING EDGES

- Panel all exposed edges with a Size 3 Bone-Eye Edge Beveler, #8076.
- Moisten the edge with a sponge dipped in water. Briskly rub edges with coarse cloth or canvas.
- As leather becomes drier, rub briskly with bone folder, apply lots of pressure, work the folder over the edges to keep them round. The bone folder also works very well on edges of several thicknesses of leather.
- Finish by drying edges. (Tandy's edge coat, #8205, is available in a 1/2 oz. edge dye, mix a small amount of Tandy's Coze Color with Tandy's Leather Weld. Paint on with brush.

OPTIONAL LINING INSTRUCTIONS

LINING AND POCKET INSTRUCTIONS - DO ALL TOOLING AND DYEING BEFORE INSTALLING LINING AND/OR POCKETS. USE A 2-2 1/2 OZ. LINING LEATHER.
NOTE: POCKET(S) MAY BE ADDED TO A LINED OR UNLINED PURSE. TO INSTALL POCKET(S) TO AN UNLINED PURSE SKIP SECTION A.

SECTION A. LINING THE PURSE

- Using kit parts as a pattern cut slightly oversized pieces of Lining Leather for both Side Panels and Bottom Panel.
- Cement oversized Lining Leather Pieces to Side Panels and Bottom Panel, flesh (rough) sides together. Trim off excess Lining Leather, ill. A. Punch 1/8" Rivet Holes and 3/64" Stitching Holes through lining, using pre-punched holes in side panels and bottom panel as a guide, ill. A.

IF NOT INCLUDING POCKET(S) PROCEED TO BAG ASSEMBLY INSTRUCTIONS.

FOLD LINE

STITCHING HOLES

POCKET CUTTING PATTERN (ACTUAL SIZE)
CUT 1 OR 2 OUT OF 2 - 2 1/2 OZ. LINING LEATHER

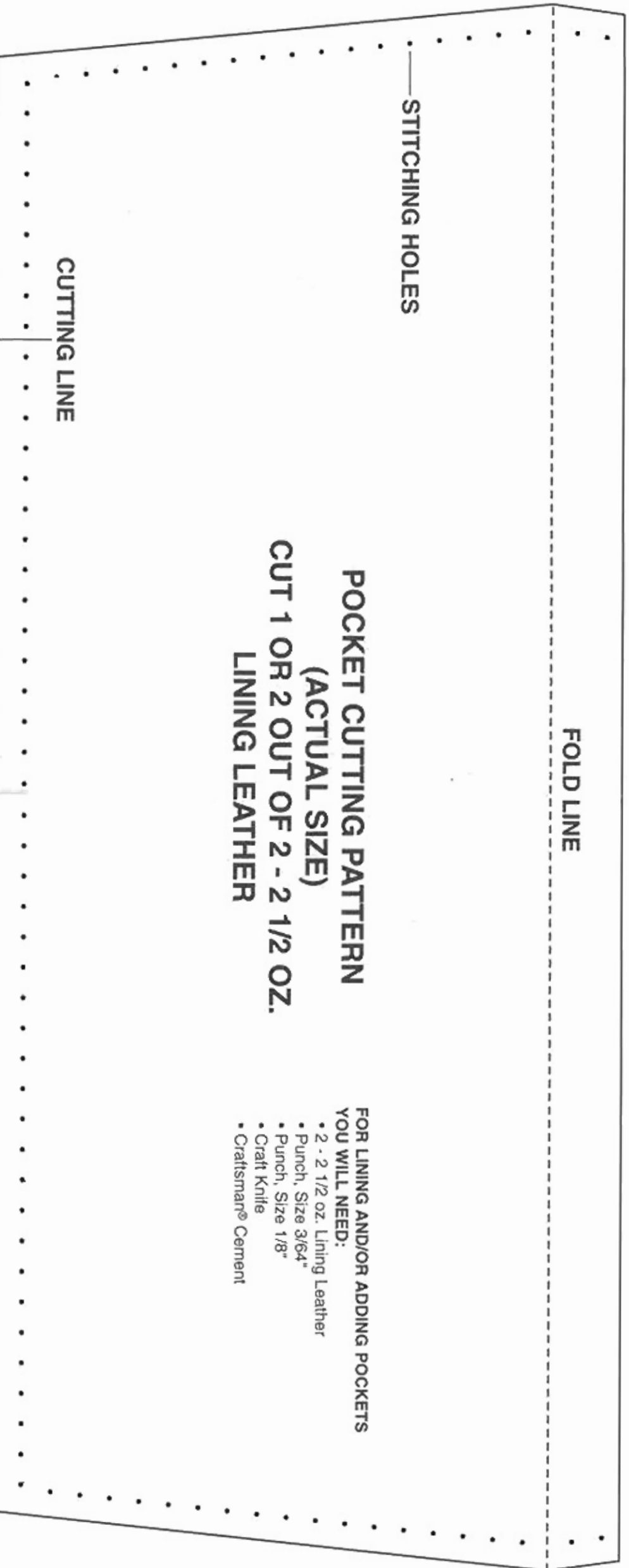

SECTION B. INSTALLING THE POCKET(S)

- Cut pocket(s) out of 2 - 2 1/2 oz. lining leather following pocket cutting pattern. Mark then punch all holes with a 3/64" punch.
- Apply cement along each side of fold line on flesh (rough) side of pocket, ill. B. Fold top of pocket over along fold line and adhere, making sure top 4 holes on each side of pocket line up. Trap folded edge flat with a mallet.
- Apply cement to rough side of bottom and side edges of pocket and to corresponding edges of lining or rough side of side panels. Adhere pocket(s) to side panel(s), ill. C. Pocket(s) should pucker when installed, ill. D.

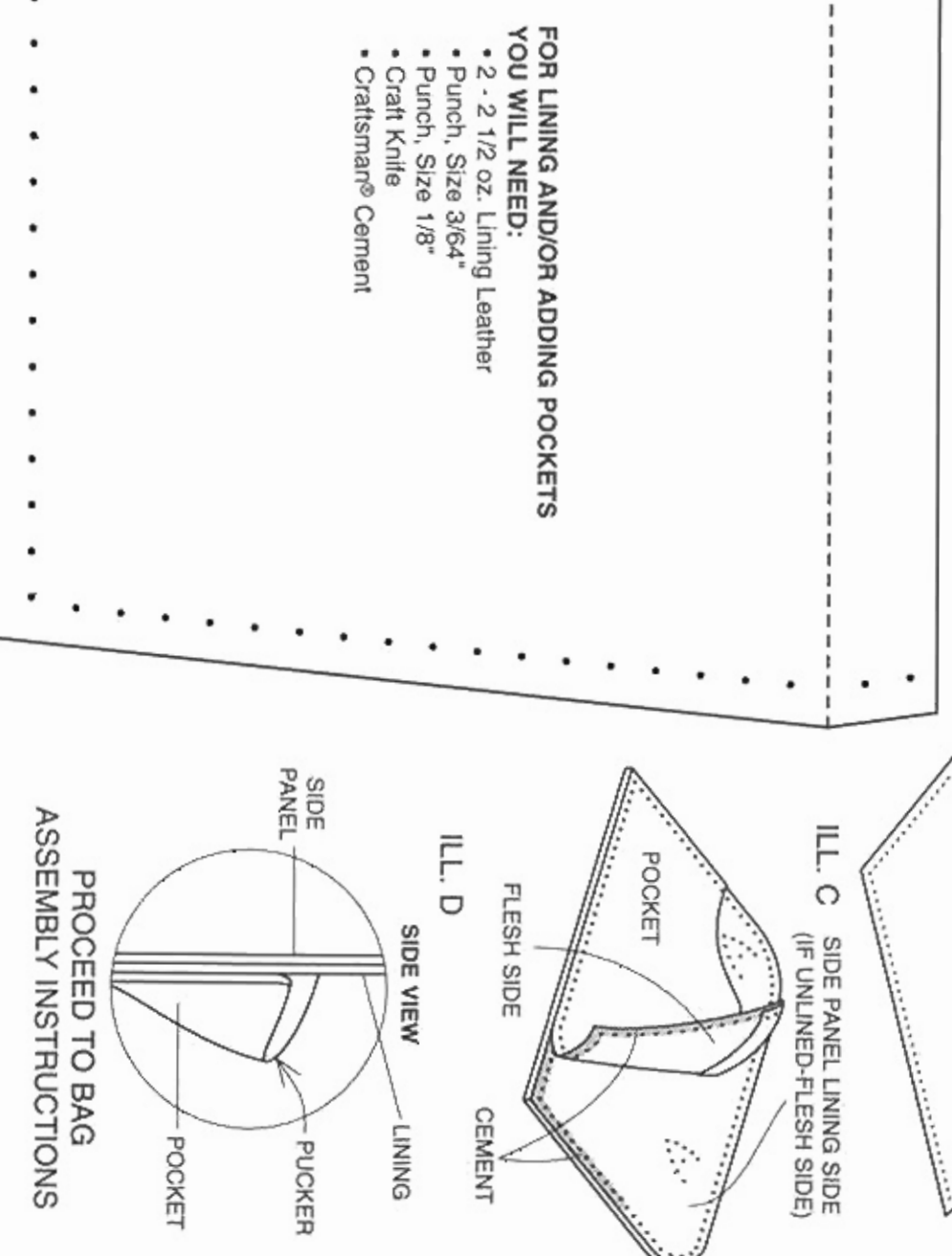

ASSEMBLY INSTRUCTIONS

NOTE: DO ALL TOOLING, DYEING AND FINISHING BEFORE BAG IS ASSEMBLED.

ATTACH HANDLES

- Cut 4 lengths of thread 23" long, to sew handle tabs onto side panels.
- Optional - For a more professional look, very carefully skew (darker area) all 4 handle tabs directly over pre-punched holes. Do not skew over last holes because the original thickness is needed for strength.

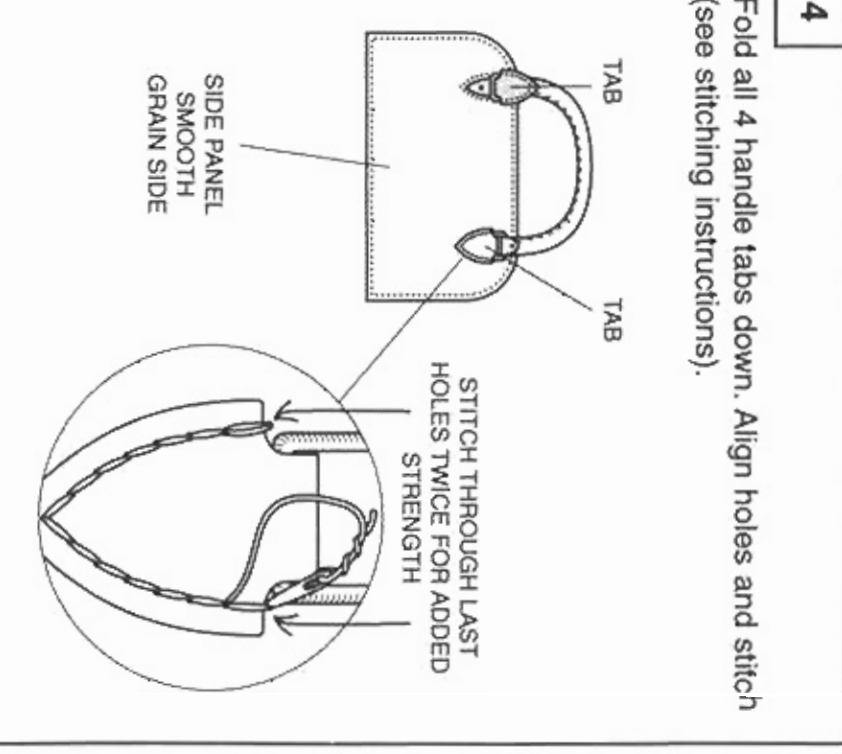
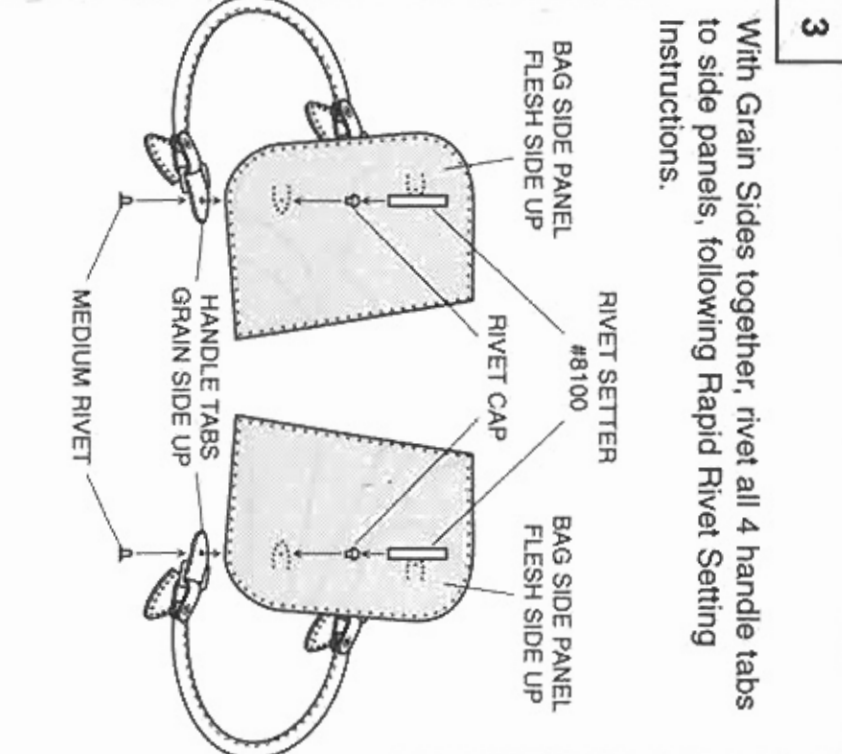
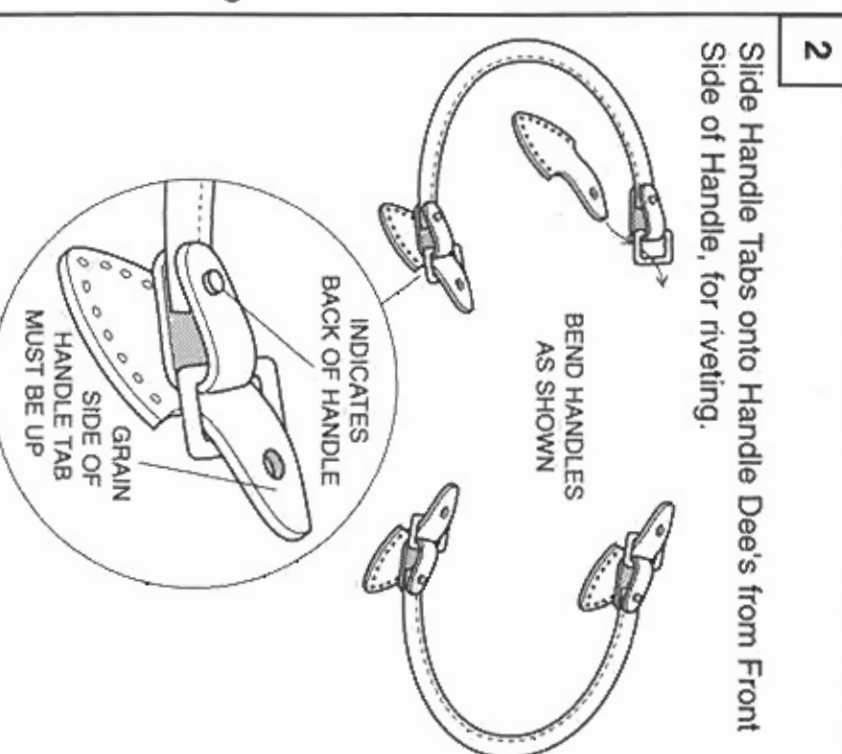

PREPARE ZIPPER GUSSET ASSEMBLY

- Optional - For a professional look, very carefully skew (darker area) ends of both pull tabs. This will help them to stand flush to the Zipper Gusset Assembly.

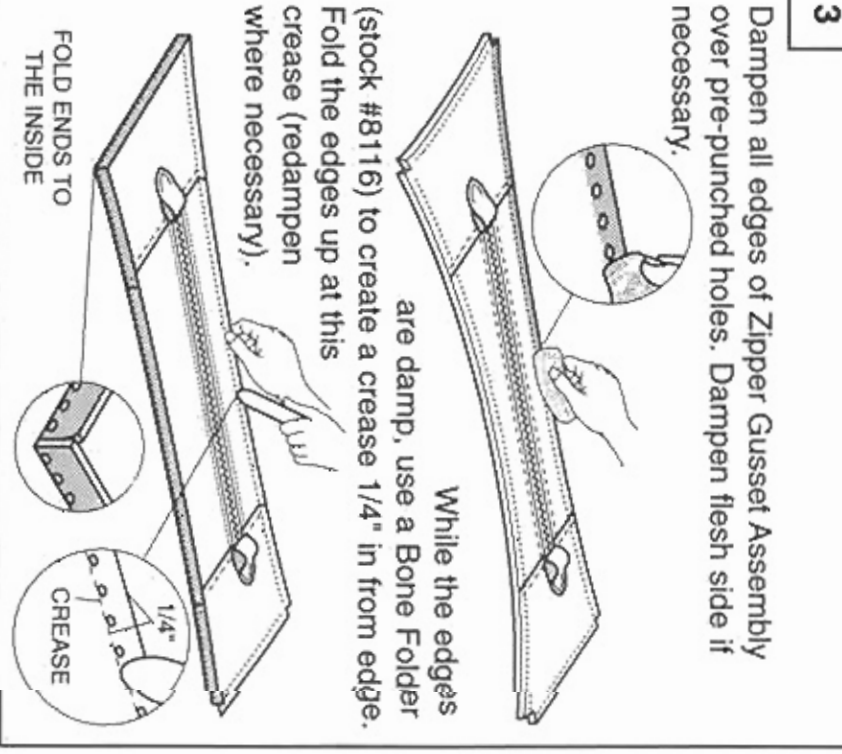
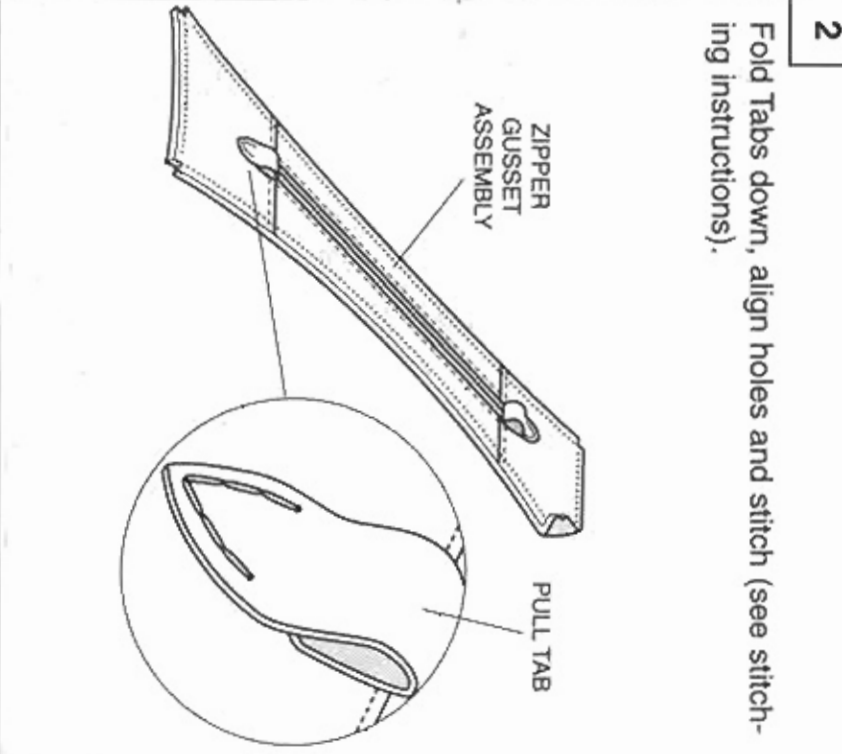
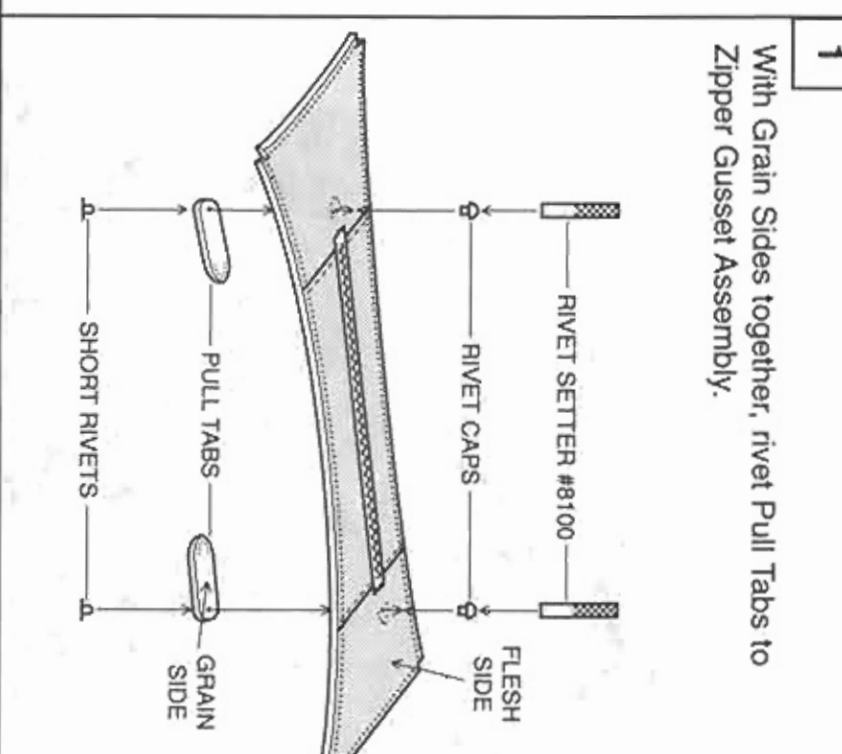

BOTTOM/SIDE PANEL ASSEMBLY

- To set Knobby Rivet, push the tack with thumb, through the bottom panel from the flesh side. Since leather will vary slightly in thickness, you should place knobby Rivet beside installed tack and check to see that it does not exceed height of button. If it does, as illustrated, clip end of tack to ensure proper fit. Set by pressing cap onto tack with fingers. DO NOT HAMMER.
- Cut 2 lengths of thread 50" long. With the grain sides of all 3 panels up, align holes and stitch side panels to bottom panel (see stitching instructions).

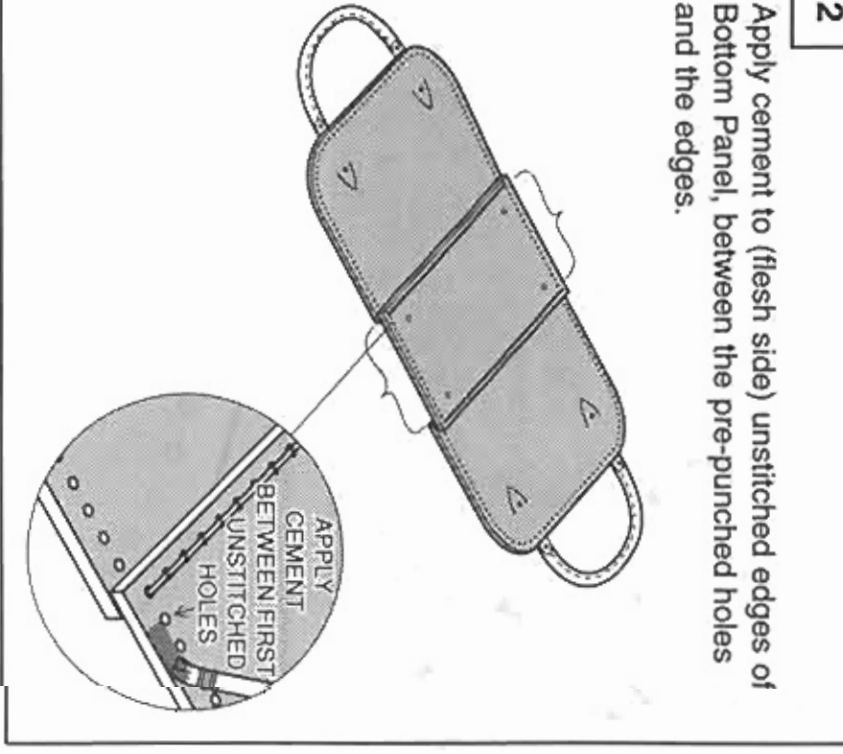
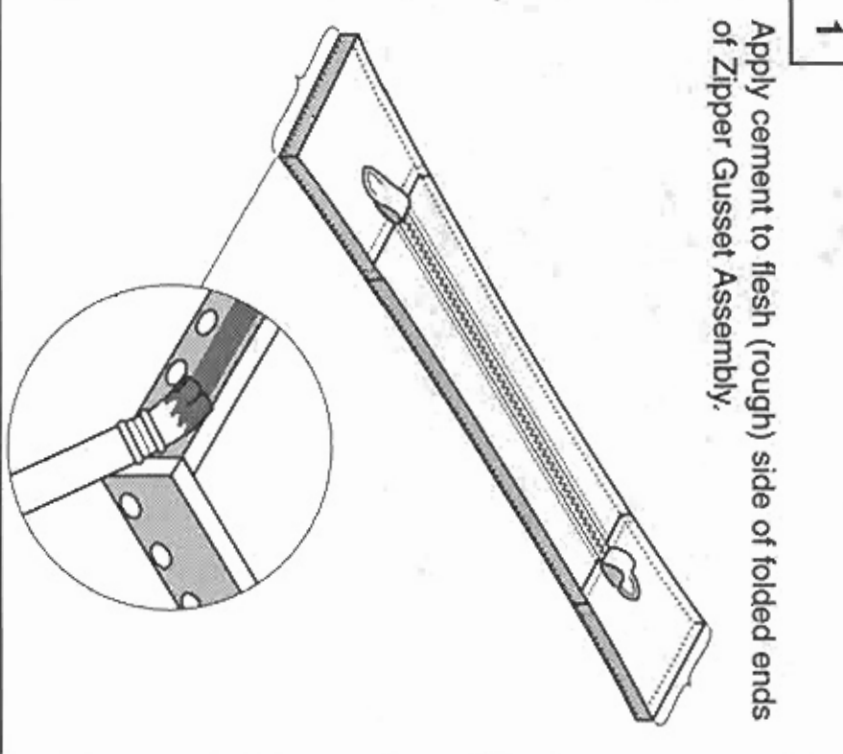
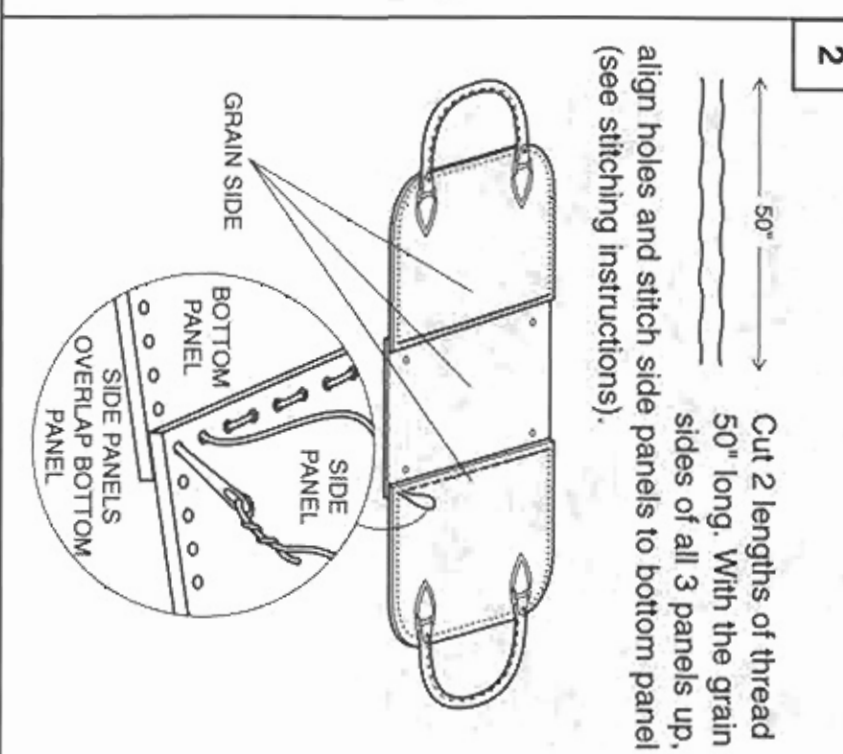

APPLY CEMENT TO BOTTOM/SIDE PANEL ASSEMBLY AND ZIPPER GUSSET ASSEMBLY.

- Using the 18 FT. remaining length of thread, begin stitching at notch (either end). Stitch to corner of Zipper Gusset Assembly, through the corner slit and the corresponding hole of the Bottom Panel.
- Apply cement to flesh side of folded edge of Zipper Gusset Assembly and to corresponding edges of Bottom and Side Panel Assembly. If necessary, use a small area at a time for proper hole alignment.
- Starting at the corner, pull the Side Panel up. Align holes and adhere edges together. The first hole will already have been stitched. Go through it again.
- Continue stitching. At the point where the Zipper Gusset Assembly is sewn together, use the space where the edges meet, as a hole.
- Continue to cement the area you are working, aligning the holes and adhering edges together. Stitch all the way around the bag. Refer back to the applicable steps if needed.

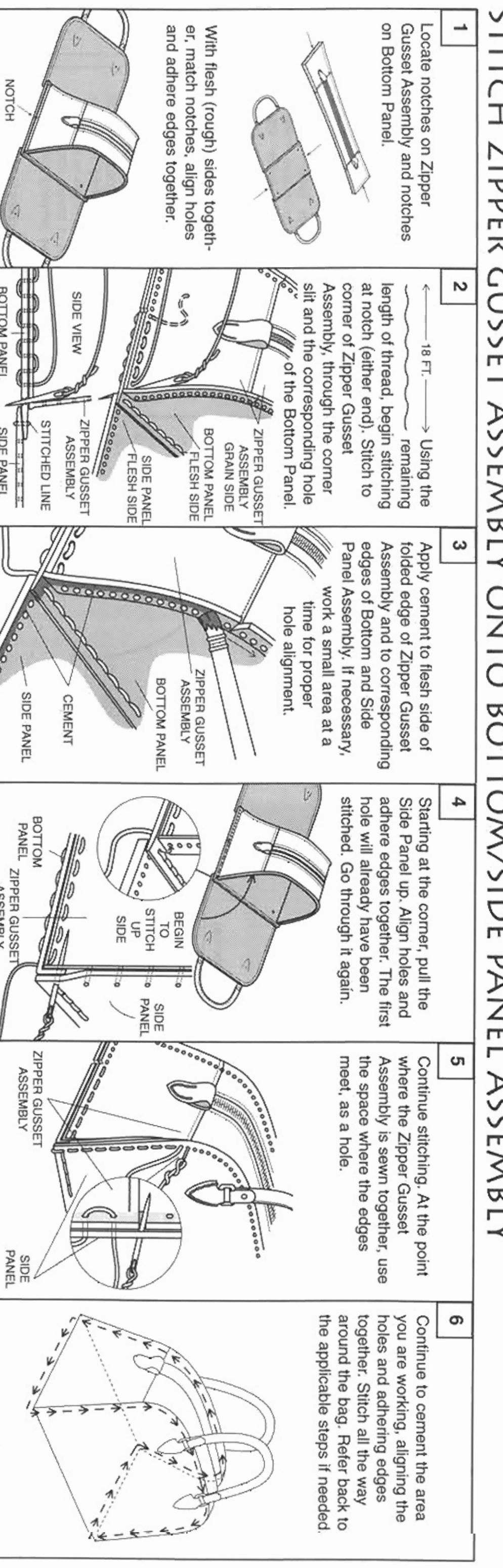

together. Trim off excess Lining Leather, Ill. A.
Punch 1/8" Rivet Holes and 3/64" Stitching Holes
through lining, using pre-punched holes in side
panels and bottom panel as a guide, Ill. A.



IF NOT INCLUDING POCKETS PROCEED TO BAG ASSI

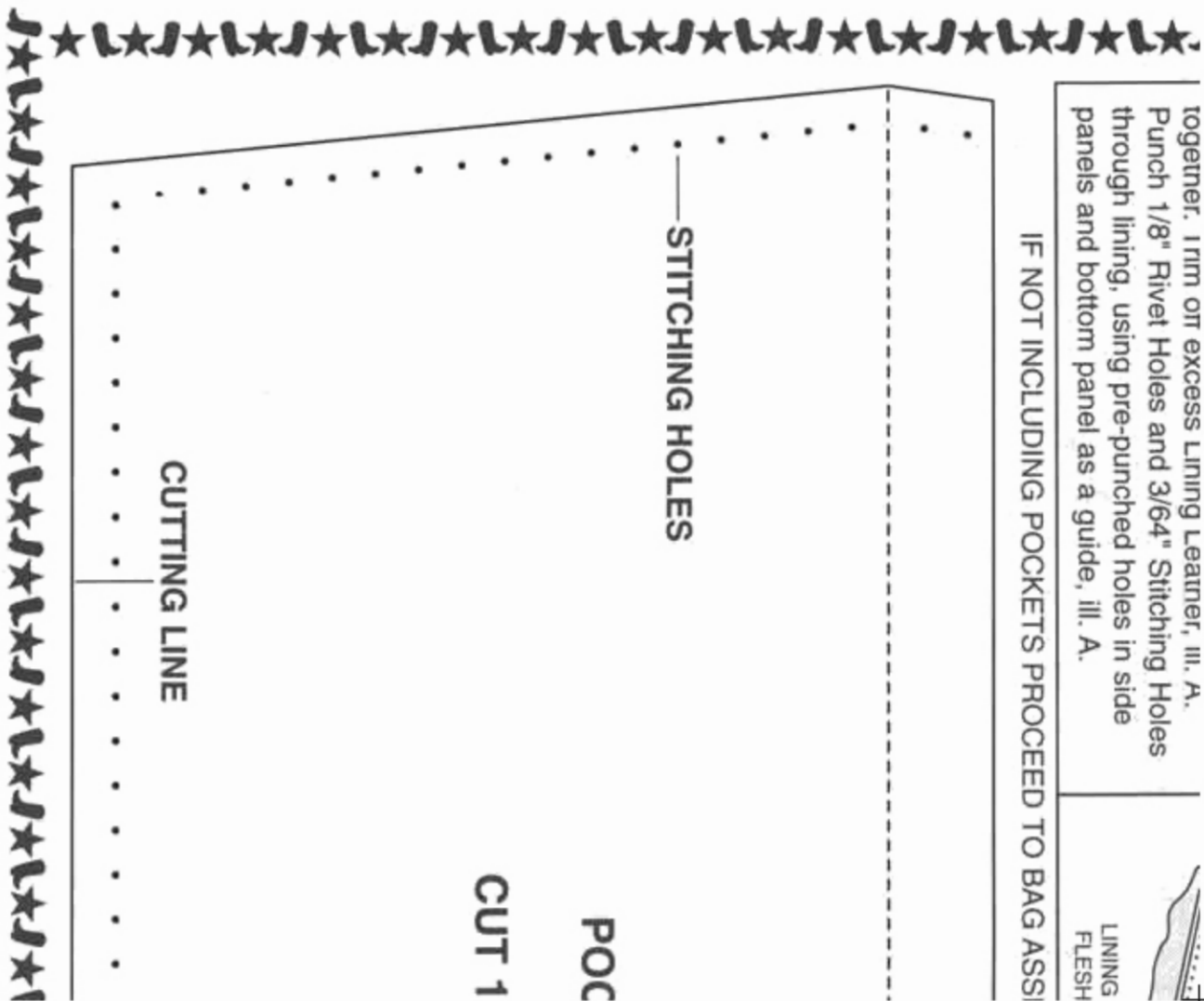



Bag Body Dimensions
 12" Long x 6" Wide x 7" Tall
 (30.48 x 15.24 x 17.78 cm)

KIT CONTAINS:

- Pre-Cut, Pre-Punched Leather Parts
- Pre-Sewn Zipper Gusset Assembly
- Rolled Handles - Ready To Attach
- Hardware - Including 4 Knobby Rivets For Feet
- Natural Color Wax Thread and Needles
- Complete Assembly Instructions - Includes Optional Lining and Pocket Instructions
- Design Suggestions

OPTIONAL:

- 15 1/2 yds. Leather Double Loop Lacing
- 2 to 2 1/2 oz. Lining Punches, if Bag is 1
- Skiving Knife
- Conchos for Decor
- Hair Call or other n
- 8 yds. additional W
- Horse Hair for Zipp

YOU WILL NEED:

- Rivet Setter, No. 8100
- Bone Folder, No. 8116
- Size 3 Bevel-Eze Edge Beveler, No. 8076
- Craftsman® Cement



OPTIONAL

LINING AND POCKET INSTRUCTIONS - DO ALL

NOTE: POCKET(S) MAY BE ADDED

SECTION A. LINING THE PUR

1	Using kit parts as a pattern cut slightly oversized pieces of Lining Leather for both Side Panels and Bottom Panel.
2	Cement oversized Lining Leather Pieces to Side Panels and Bottom Panel, flesh (rough) sides

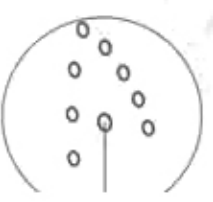

SATCHEL BAG
STOCK NO. 4370

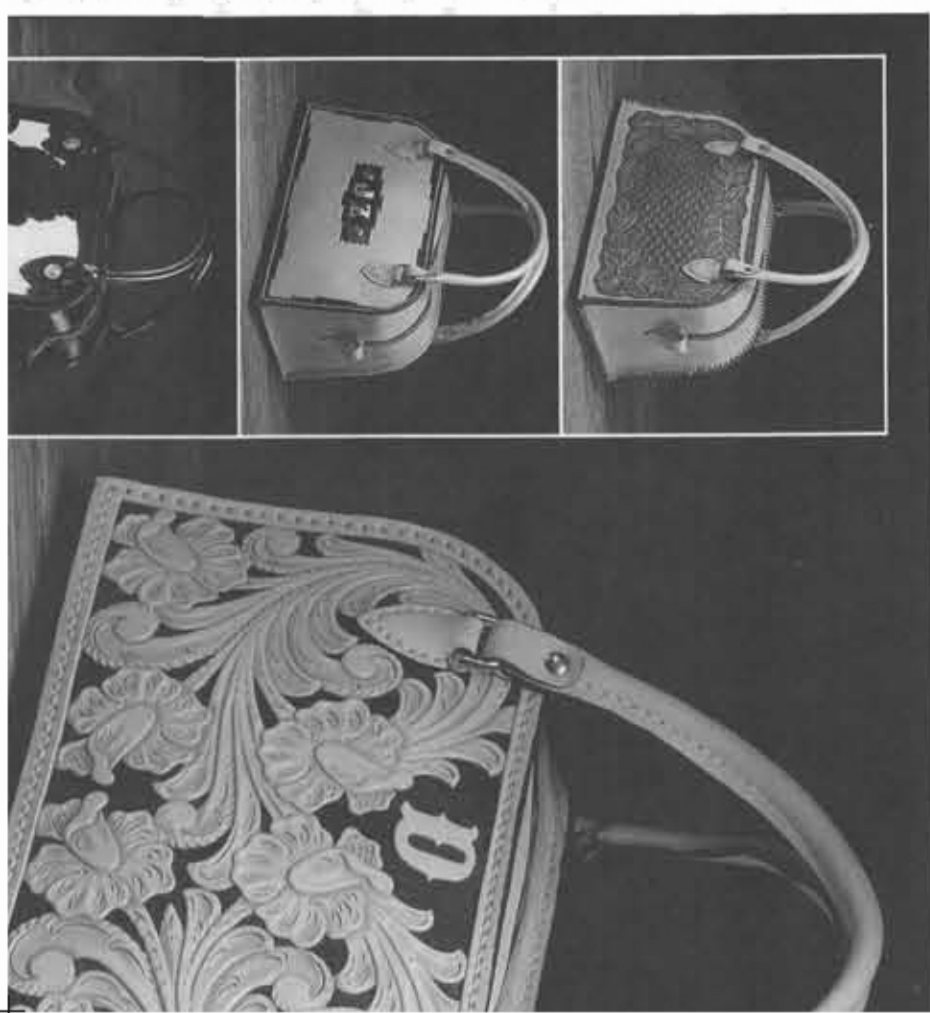

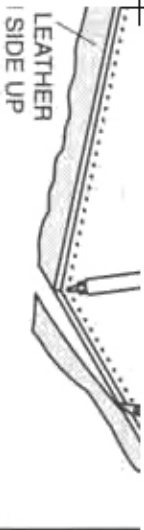

SEMBLY INSTRUCTIONS.

(rough) side of pocket, III. D. Fold top of pocket over along fold line and adhere, making sure top 4 holes on each side of pocket line up. Tap folded edge flat with a mallet.

FOLD LINE

**POCKET CUTTING PATTERN
(ACTUAL SIZE)
OR 2 OUT OF 2 - 2 1/2 OZ.
LINING LEATHER**

**FOR LINING AND/OR ADDING POCKETS
YOU WILL NEED:**

- 2 - 2 1/2 oz. Lining Leather
- Punch, Size 3/64"
- Punch, Size 1/8"
- Craft Knife
- Craftsman® Cement

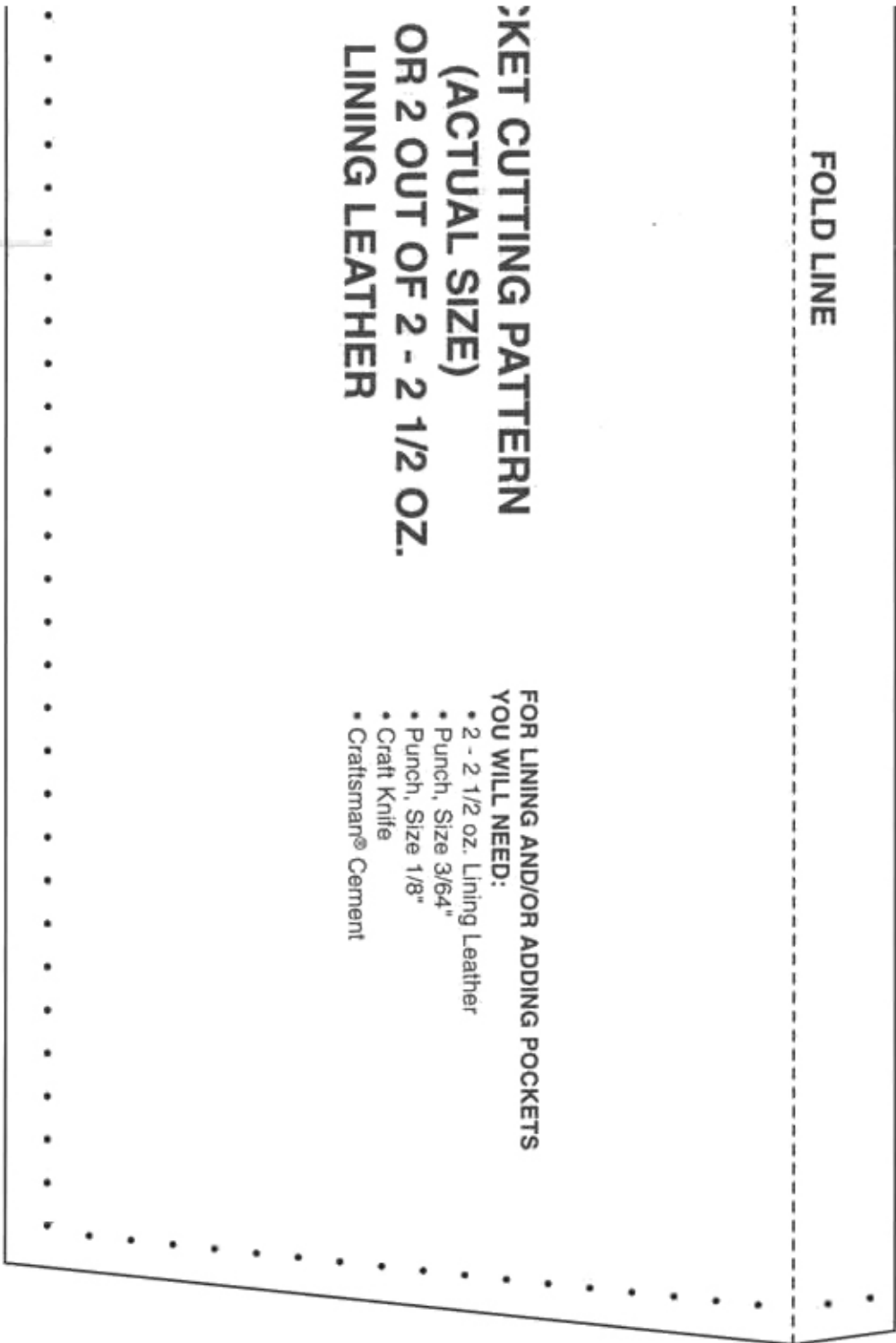

ILL. B 1/4" FOLDED EDGE WITH MALLET

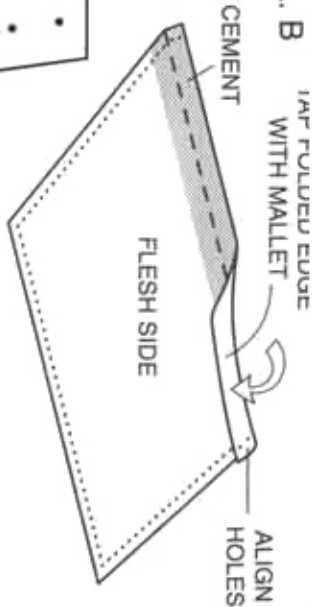

ILL. C SIDE PANEL LINING SIDE (IF UNLINED-FLESH SIDE)

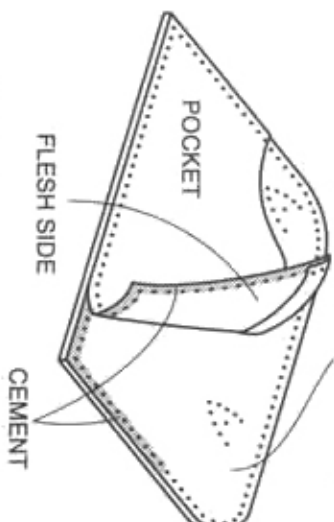

ILL. D

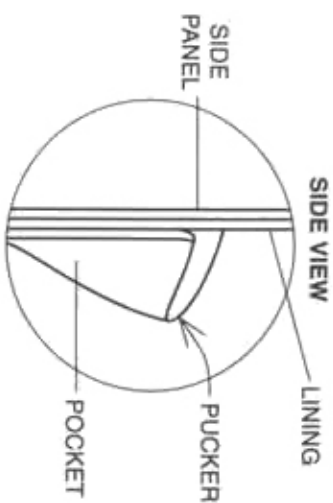

PROCEED TO BAG
ASSEMBLY INSTRUCTIONS





Lace and Lacing Needle for
 3 Leather and 1/8" and 3/64"
 to be Lined

ations
 aterial for inserts
 axed Thread for inserts
 er Pull Tassel

Distributed by
 Tandy Leather Co.
 Fort Worth, Texas 76140

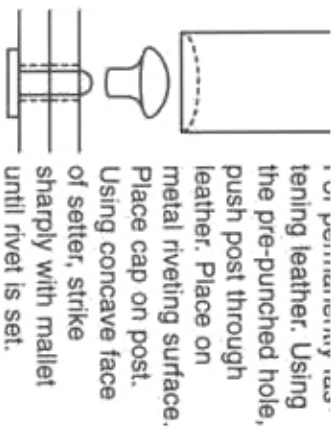

NOTE: Before tooling, dyeing and finishing, adhere heavy paper or stiff cardboard to flesh side of panels. This will prevent leather from stretching or shrinking. After dyes and finishes are completely dry, carefully remove cardboard from leather.



1 Bevel all exposed edges with a Size 3 Bevel-Eze Edge Beveler, #8076.



2 Moisten the edge with a sponge dipped in water. Briskly rub edges with coarse cloth or canvas.

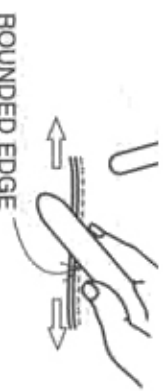

3 As leather becomes drier, rub briskly with bone folder, apply lots of pressure, work the folder over the edges to keep them round. The bone folder also works very well on edges of several thicknesses of leather.

4 Finish by dyeing edges. (Tandy's' edge coat, #2025, gives a professional finished look to the backs and edges). To make your own high gloss edge dye, mix a small amount of Tandy's' Cova Color with Tandy's' Leather Weld. Paint on with brush.

ALL LINING INSTRUCTIONS

TOOLING AND DYEING BEFORE INSTALLING LINING AND/OR POCKET(S). USE A 2-2 1/2 OZ. LINING LEATHER. TO A LINED OR UNLINED PURSE. TO AN UNLINED PURSE SKIP SECTION A.

SECTION B. INSTALLING THE POCKET(S)

ILL. A

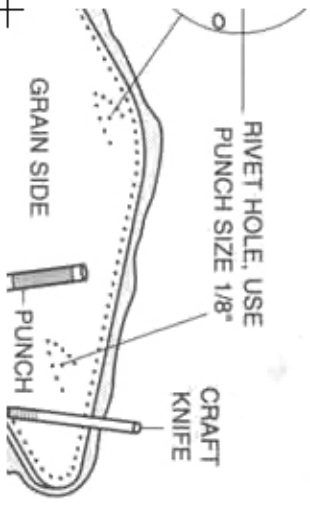

<p>1 Cut pocket(s) out of 2 - 2 1/2 oz. lining leather following pocket cutting pattern. Mark then punch all holes with a 3/64" punch.</p>	
<p>2 Apply cement along each side of fold line on flesh side of pocket.</p>	<p>3 Apply cement to rough side of bottom and side edges of pocket and to corresponding edges of lining or rough side of side panels. Adhere pocket(s) to side panel(s), ill. C. Pocket(s) should pucker when installed, ill. D.</p>

KIT

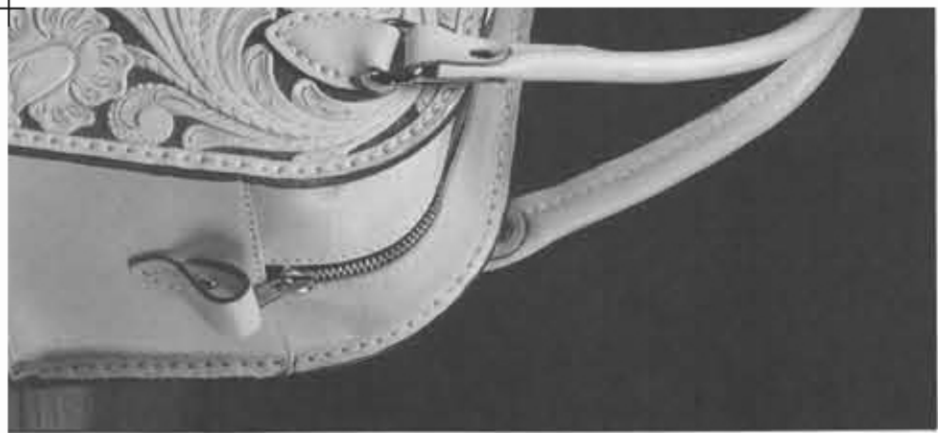

KIT PARTS

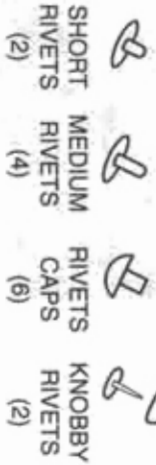
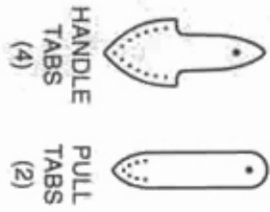
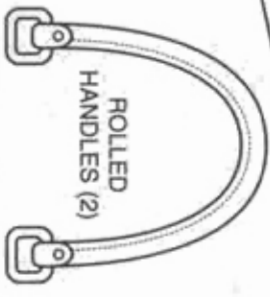
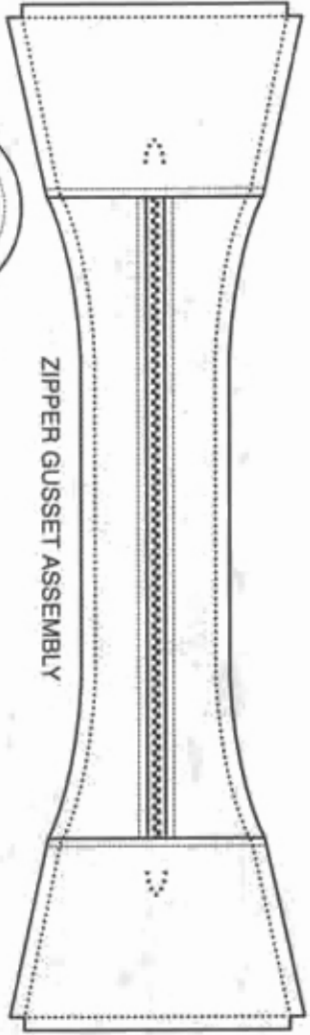

RAPID RIVET SETTING

INSTRUCTIONS

BURNISHING EDGES

Burnished edges add the finishing touches and professional look. All exposed edges should be burnished.

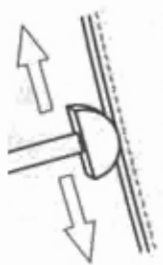

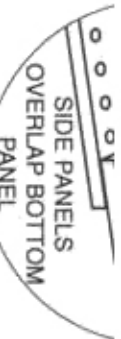
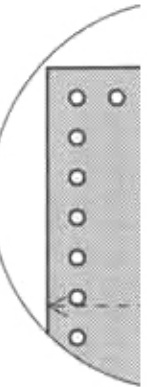

STITCH ZIPPER GUSSET ASSEMBLY ONTO BOTTOM/SIDE

1

Locate notches on Zipper Gusset Assembly and notches on Bottom Panel.

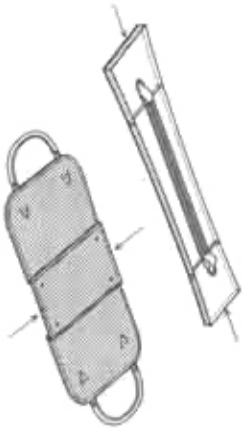

With flesh (rough) sides together, match notches, align holes and adhere edges together.

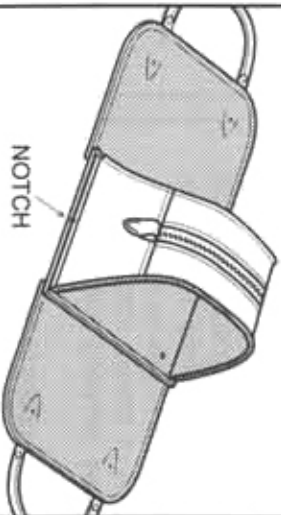

2

Using the 18 FT. remaining length of thread, begin stitching at notch (either end). Stitch to corner of Zipper Gusset Assembly, through the corner slit and the corresponding hole of the Bottom Panel.

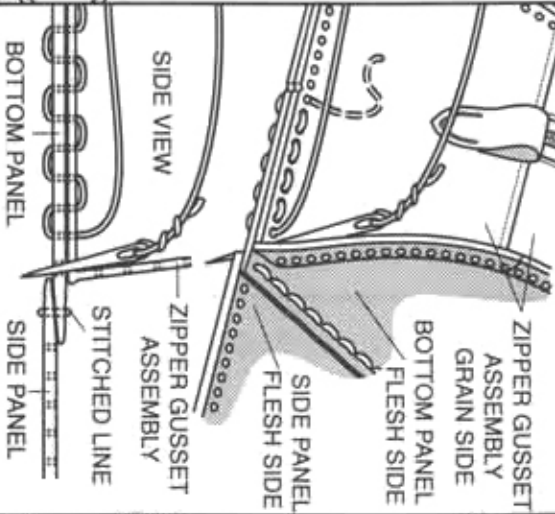

3

Apply cement to flesh side of folded edge of Zipper Gusset Assembly and to corresponding edges of Bottom and Side Panel Assembly. If necessary, work a small area at a time for proper hole alignment.

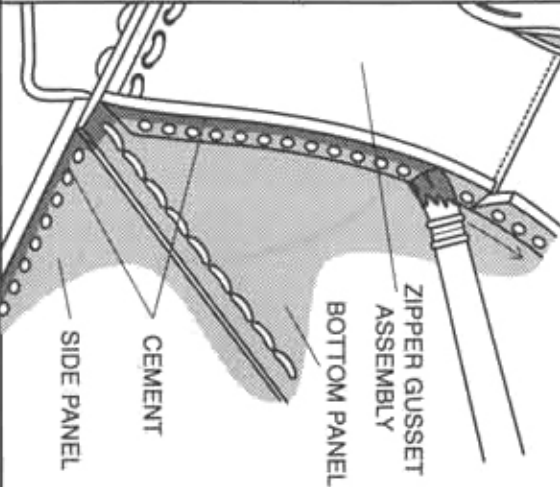

4

Starting at the corner Side Panel up. Align adhere edges together, hole will already have stitched. Go through

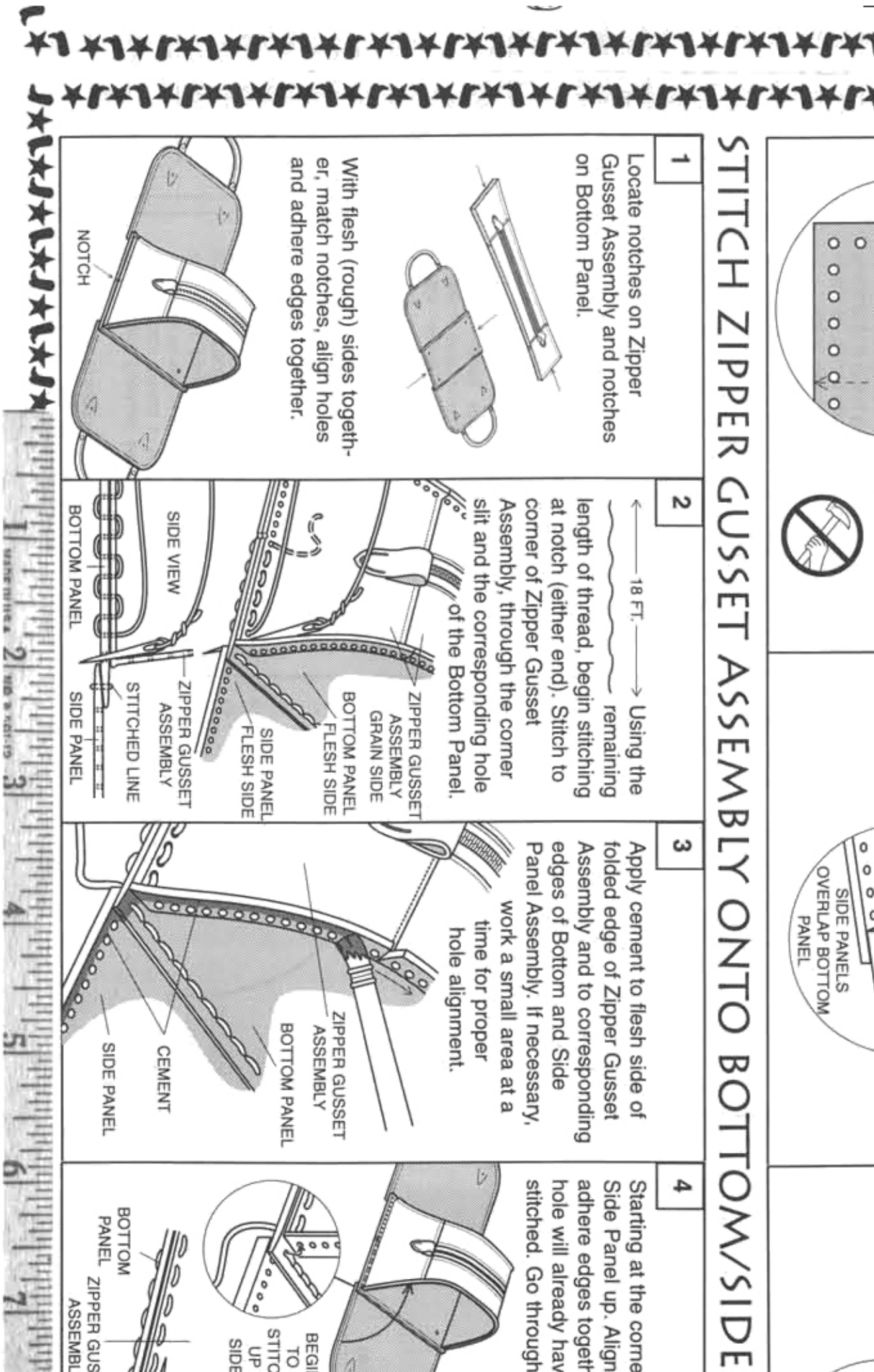
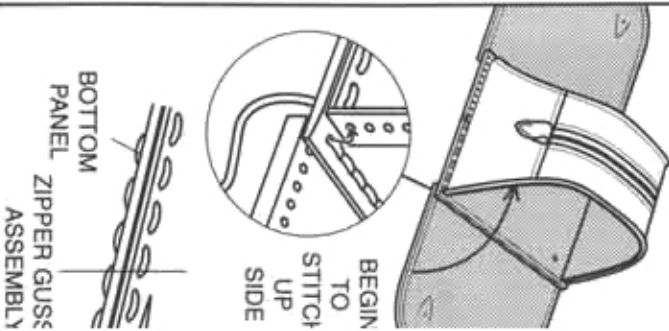

Open the ends of the pull tabs together, rivet in the zipper gusset skive (darker area) ends of both pull tabs. This will help them to stand flush to the Zipper Gusset Assembly.

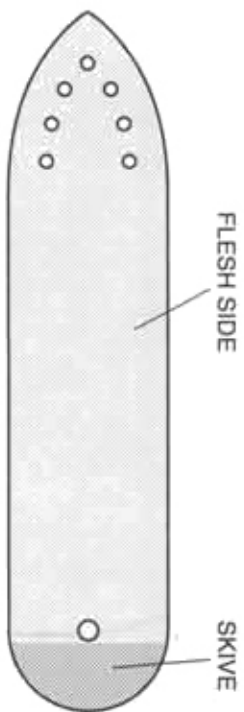

Zipper Gusset Assembly.

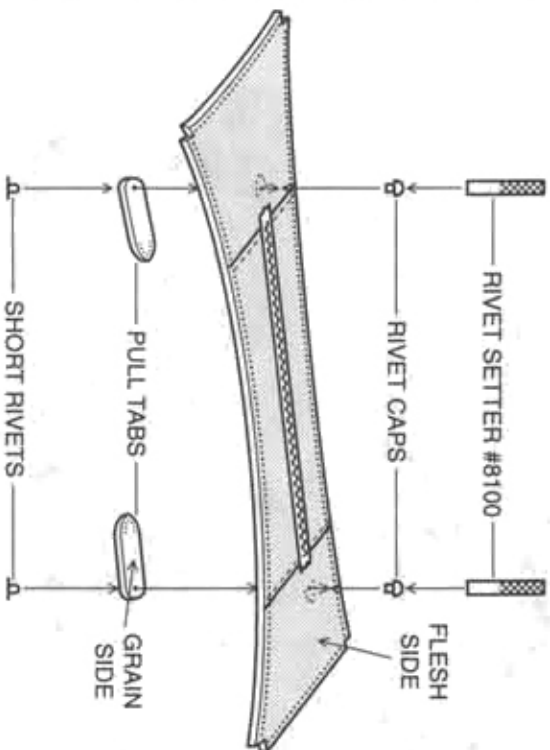

Zipper Gusset Assembly.

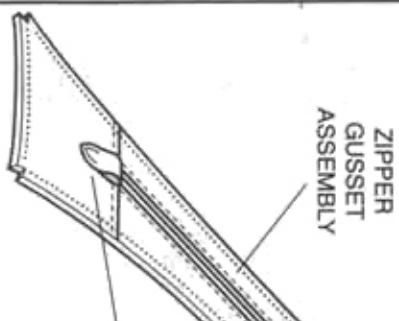

BOTTOM/SIDE PANEL ASSEMBLY

APPLY CEMENT

1

To set Knobby Rivet, push the tack with thumb, through the bottom panel from the flesh side. Since leather will vary slightly in thickness, you should place Knobby Button beside installed tack and check to see that it does not exceed height of button. If it does, as illustrated, clip end of tack to ensure proper fit. Set by pressing cap onto tack with fingers, **DO NOT HAMMER**.

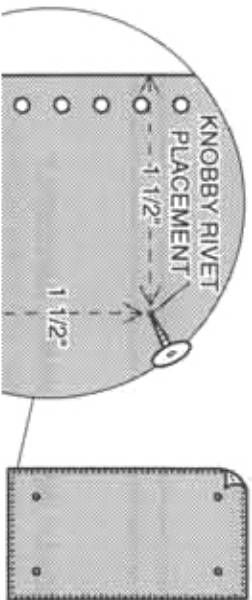

2

Cut 2 lengths of thread 50" long. With the grain sides of all 3 panels up, align holes and stitch side panels to bottom panel (see stitching instructions).

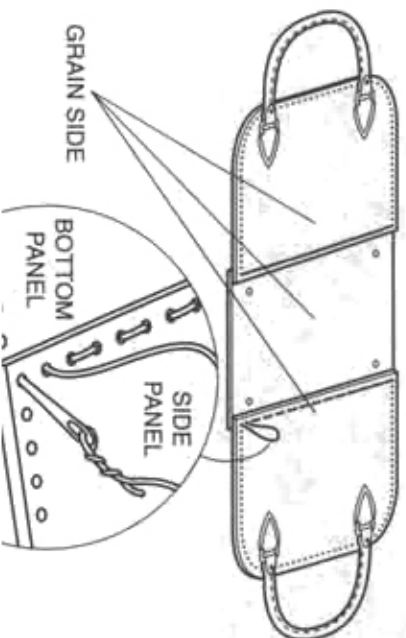

1

Apply cement to flesh of Zipper Gusset Ass

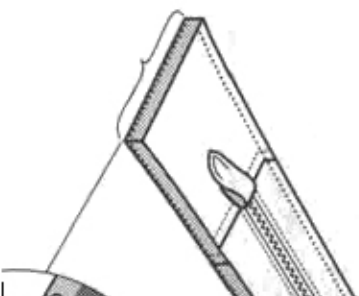

ASSEMBLY INSTRUCTIONS

ATTACH HANDLES

NOTE: DO ALL TOOLING, DYEING AND FINISHING BEFORE ASSEMBLY

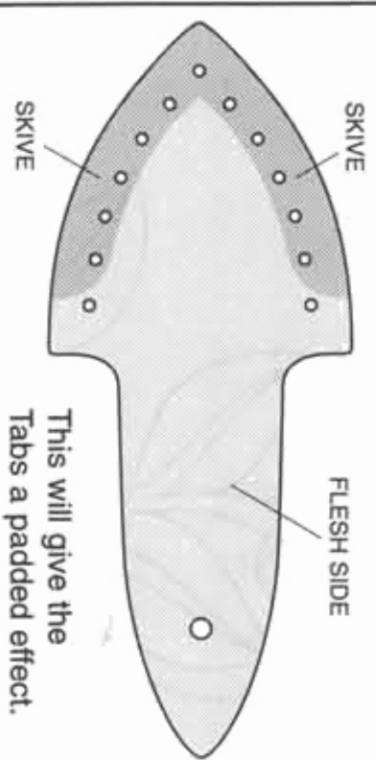
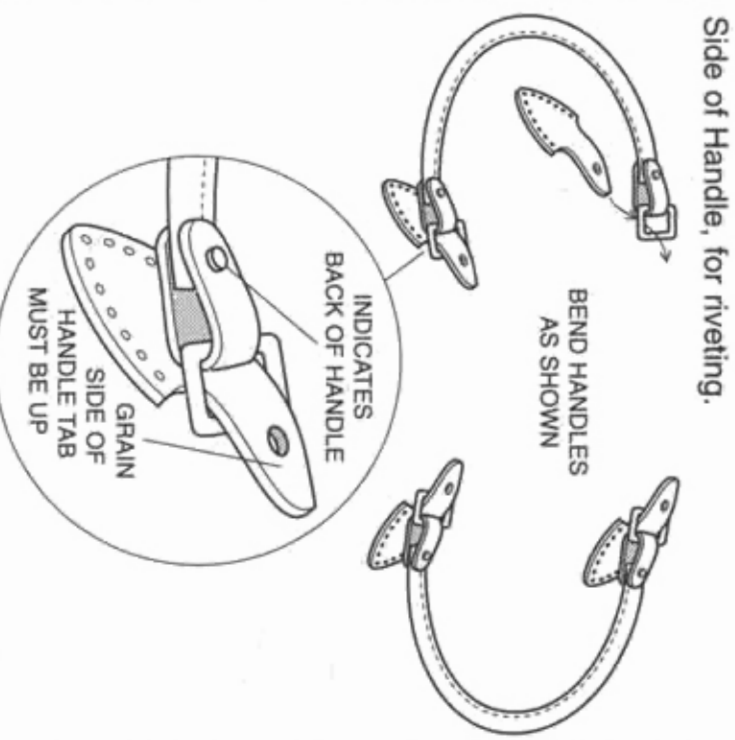
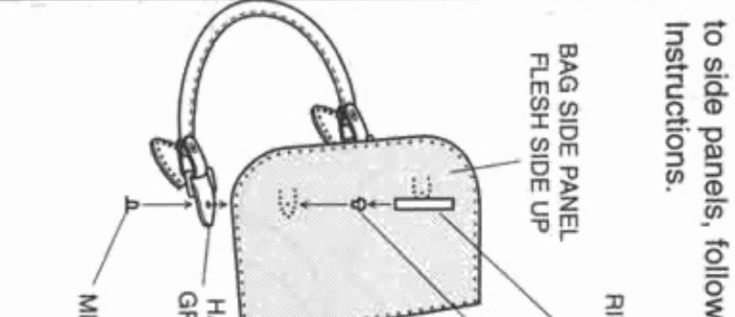
<p>1</p> <p>← 23" → Cut 4 lengths of thread 23" long, to sew handle tabs onto side panels.</p> <p><i>Optional</i> - For a more professional look, very carefully skive (darker area) all 4 handle tabs directly over pre-punched holes. Do not skive over last holes because the original thickness is needed for strength.</p> 	<p>2</p> <p>Slide Handle Tabs onto Handle Dees from Front Side of Handle, for riveting.</p> 	<p>3</p> <p>With Grain Sides together to side panels, follow instructions.</p> 
--	---	---

PREPARE ZIPPER GUSSET ASSEMBLY

Optional - For a professional look vary carefully

1 With Grain Sides together rivet Pull Tabs to

2 Fold Tabs down along

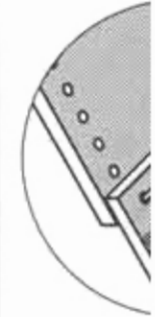

PANEL ASSEMBLY

5, pull the holes and er. The first a been it again.

5

Continue stitching. At the point where the Zipper Gusset Assembly is sewn together, use the space where the edges meet, as a hole.

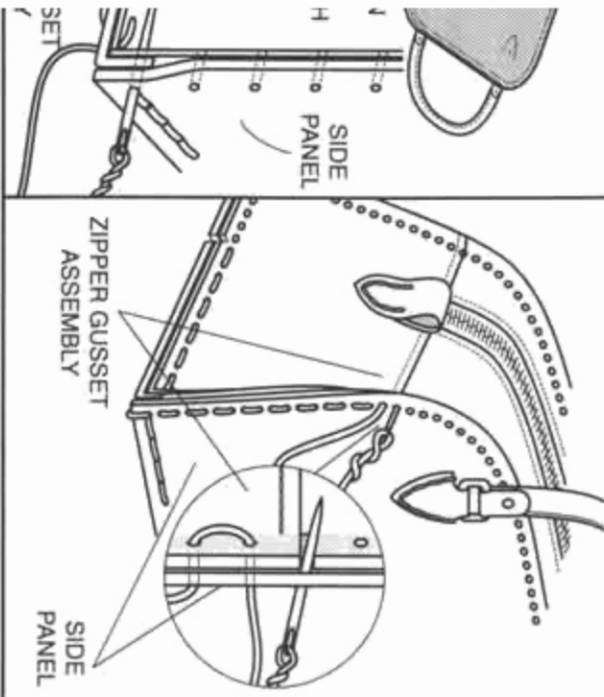

6

Continue to cement the area you are working, aligning the holes and adhering edges together. Stitch all the way around the bag. Refer back to the applicable steps if needed.

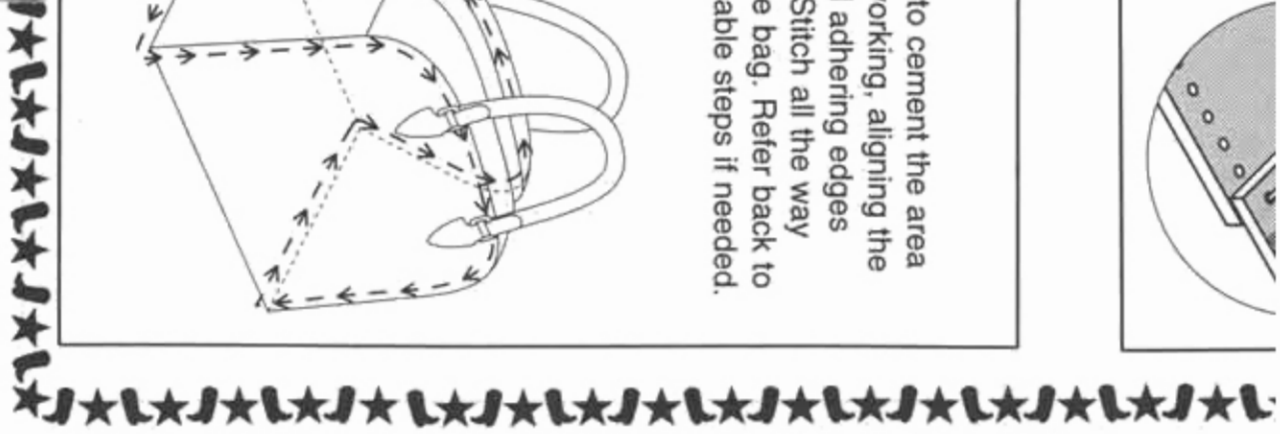
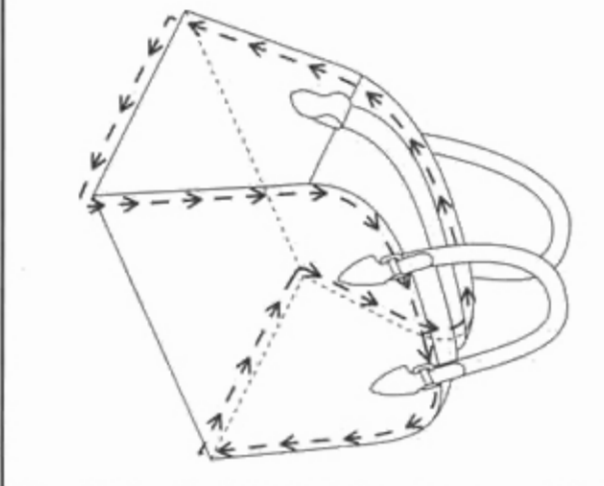

over pre-punched holes. Dampen flesh side if necessary.

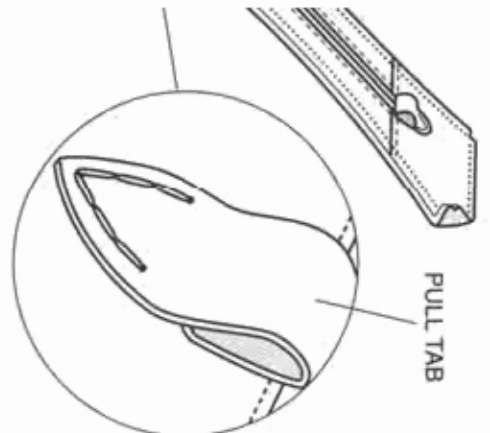

PULL TAB

While the edges are damp, use a Bone Folder (stock #8116) to create a crease 1/4" in from edge. Fold the edges up at this crease (redampen where necessary).

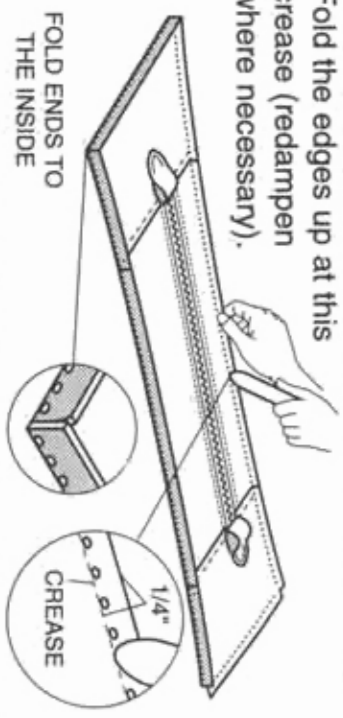

FOLD ENDS TO THE INSIDE

1/4" CREASE

MENT TO BOTTOM/SIDE PANEL ASSEMBLY AND ZIPPER CUSSET ASSEMBLY.

2

h (rough) side of folded ends assembly.

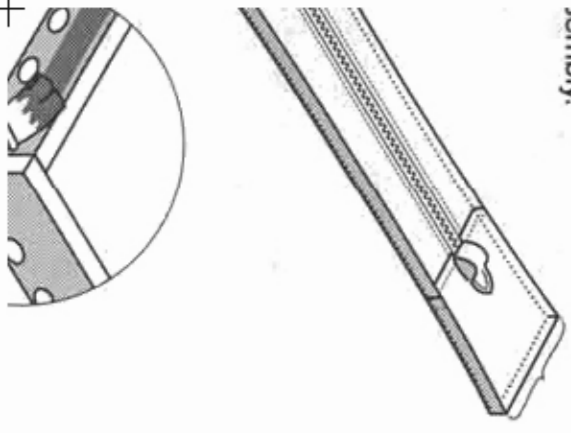

Apply cement to (flesh side) unstitched edges of Bottom Panel, between the pre-punched holes and the edges.

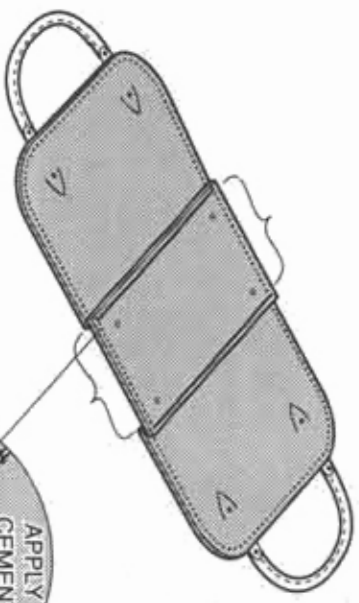

APPLY CEMENT BETWEEN FIRST UNSTITCHED HOLES



INSTRUCTIONS

HINGE BEFORE BAG IS ASSEMBLED.

either, rivet all 4 handle tabs using Rapid Rivet Setting

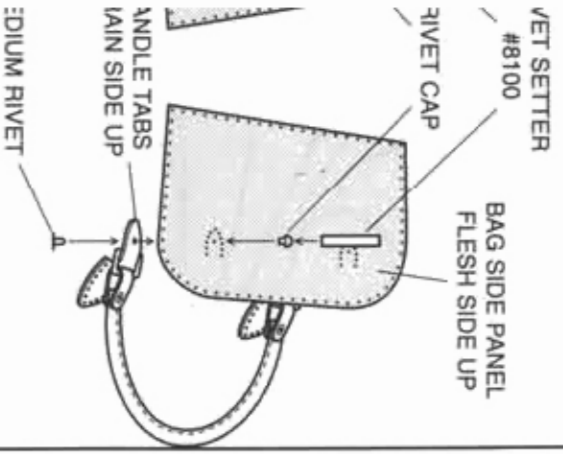

4

Fold all 4 handle tabs down. Align holes and stitch (see stitching instructions).

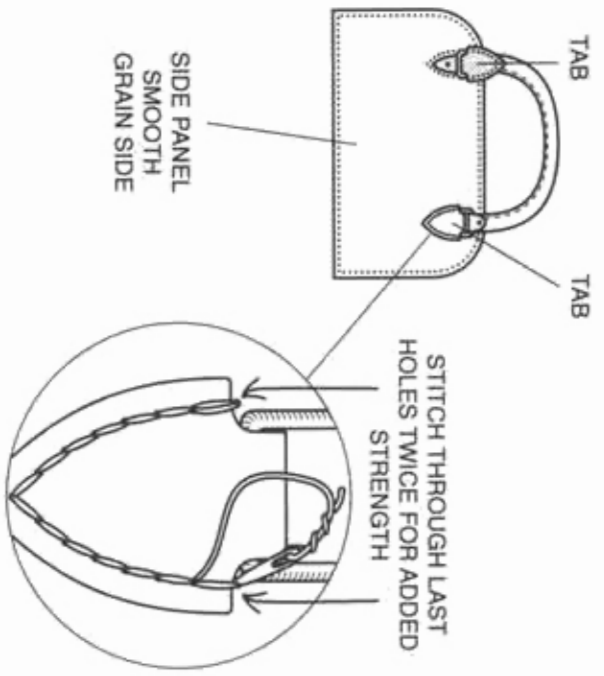

3

Dampen all edges of Zipper Gusset Assembly

holes and stitch (see stitch-



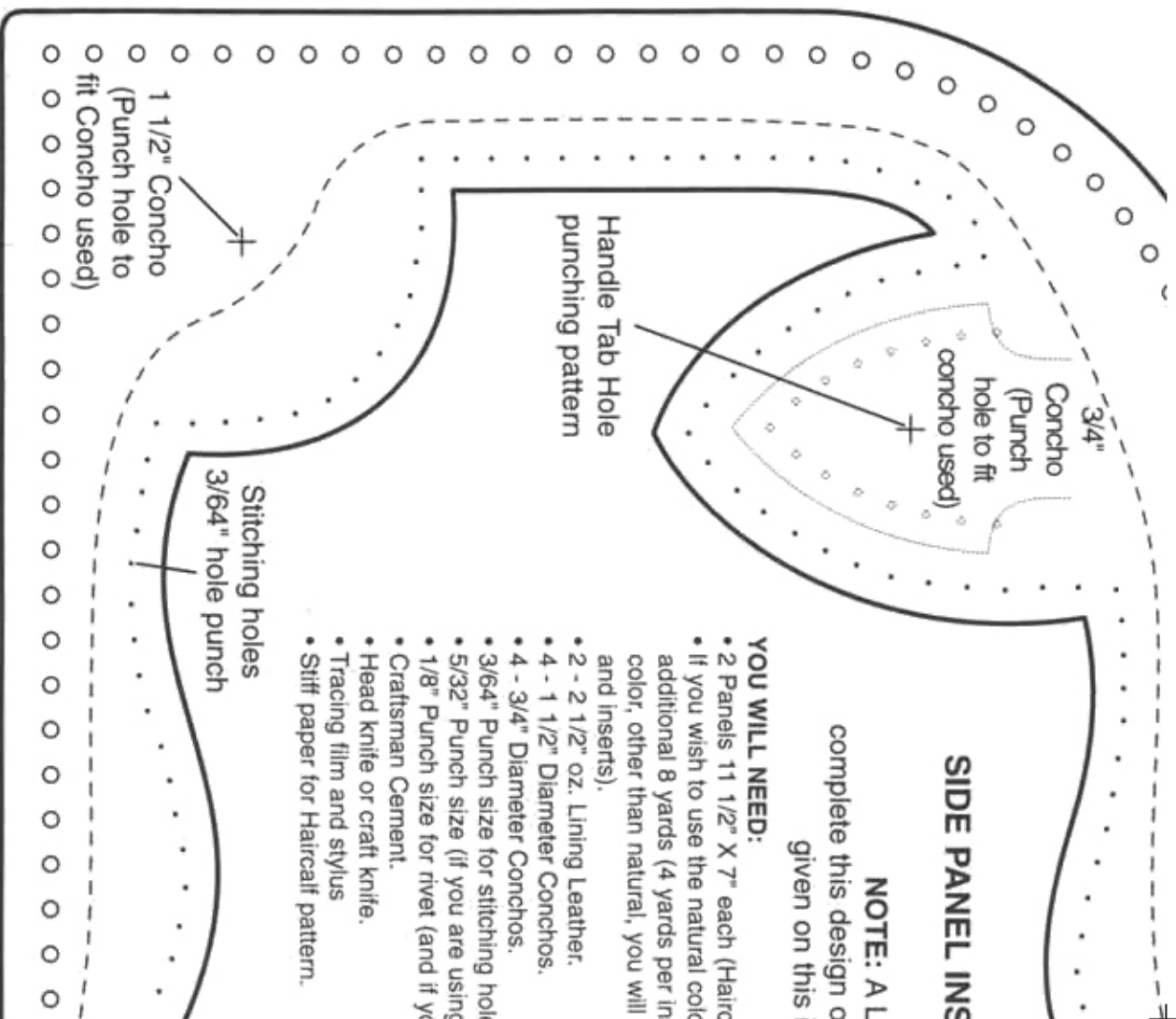

SIDE PANEL INS

NOTE: ALL complete this design o given on this i

YOU WILL NEED:

- 2 Panels 11 1/2" X 7" each (Hairc
- If you wish to use the natural colc additional 8 yards (4 yards per in color, other than natural, you will and inserts).
- 2 - 2 1/2" oz. Lining Leather.
- 4 - 1 1/2" Diameter Conchos.
- 4 - 3/4" Diameter Conchos.
- 3/64" Punch size for stitching holi
- 5/32" Punch size (if you are using
- 1/8" Punch size for rivet (and if yc
- Craftsman Cement.
- Head knife or craft knife.
- Tracing film and stylus
- Stiff paper for Haircalf pattern.

Handle Tab Hole punching pattern

Concho (Punch hole to fit concho used)

1 1/2" Concho (Punch hole to fit Concho used)

Stitching holes 3/64" hole punch



V707

V407

C940

P217



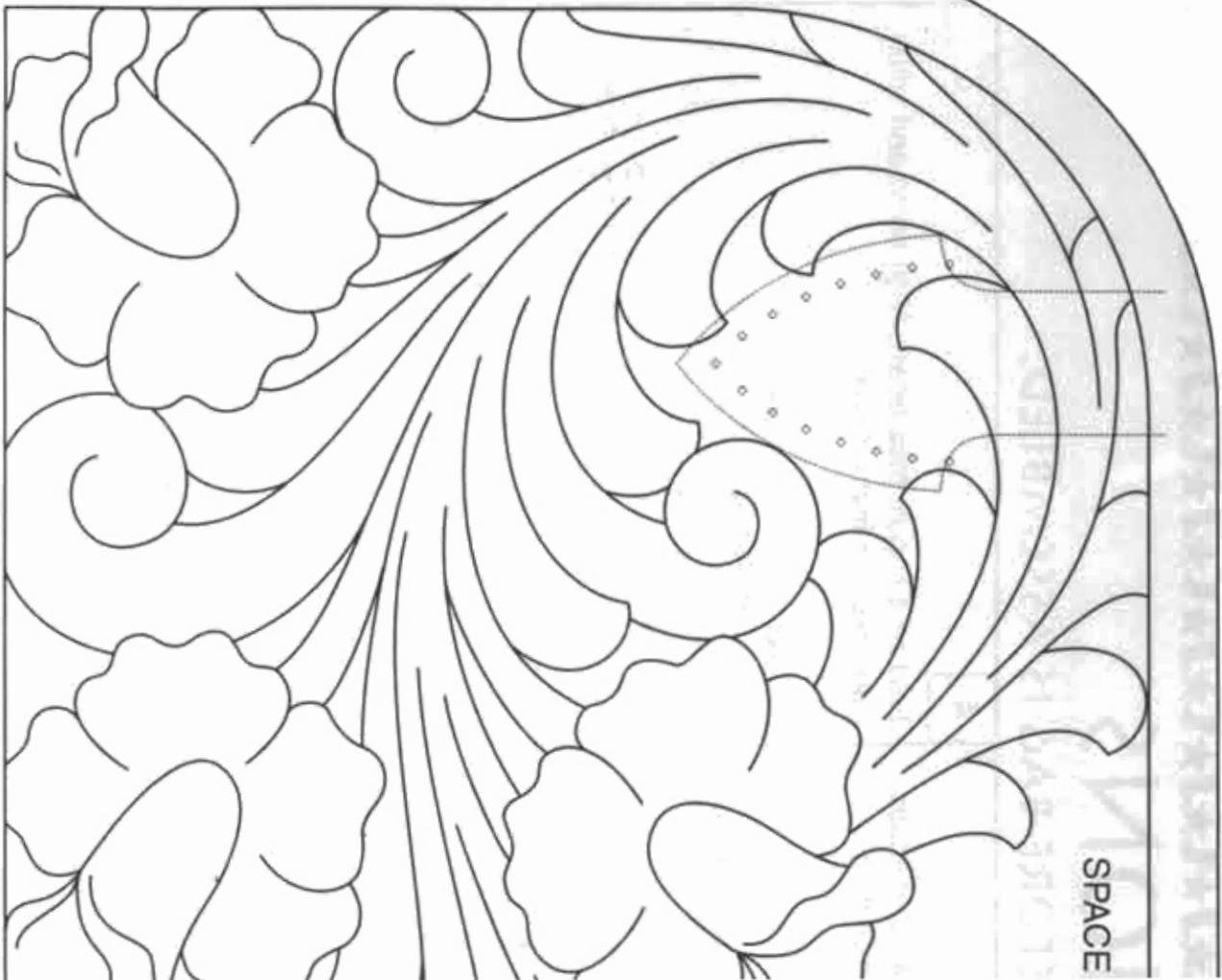

SPACE

1 The eye of Wrap finger; top pile thread down; leather stitch; each :

NOTI filling needli osly put th previc ing in



INSERT CUTTING PATTERN

lining must be used to option. Refer to Lining Instructions instruction/pattern sheet.

ail or other exotic material) or thread included in this kit you will need an ser). However, if you wish to use a different need a total of 23 yards (includes bag assembly

es.
3 screw on conchos),
du are using rivet on conchos).

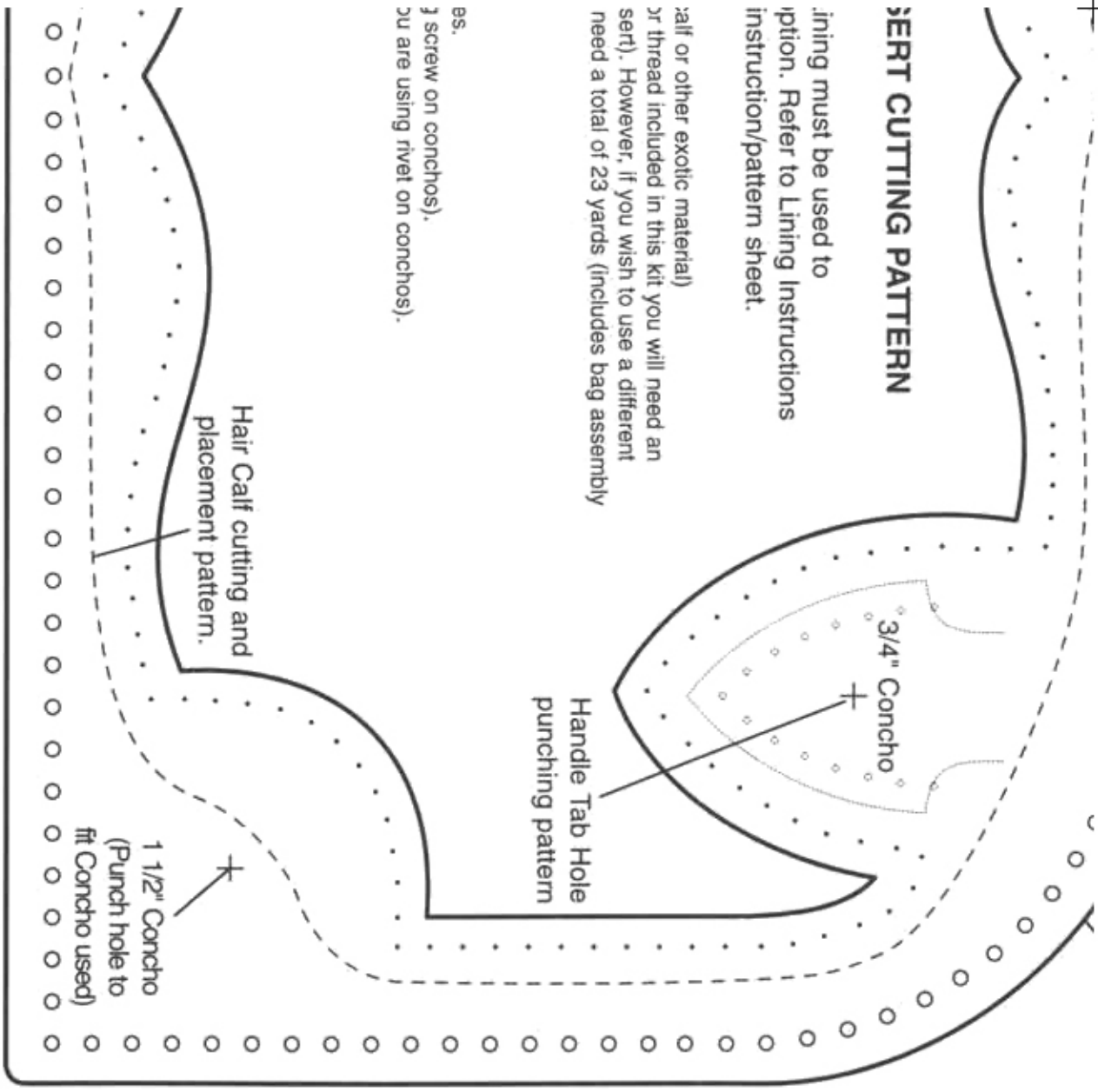

fer side panel insert cutting line and all stitching and concho holes to both side panels, as shown on side panel insert cutting pattern at left.

STEP 2. Carefully cut insert area out of both panels. Punch all stitching and concho holes transferred in Step 1.

STEP 3. Transfer, then punch concho holes in all 4 handle tabs as shown on handle tab concho hole punching pattern.

STEP 4. Apply dye or stain, being sure it gets into the holes, and a finish to both side panels and all 4 handle tabs. Dye or stain and finish all bag parts.

STEP 5. Using stiff paper, make a pattern for the Haircalf using the Haircalf cutting/placement pattern (dashed line). With a ballpoint pen, trace around the paper pattern on the flesh sides of both Haircalf panels, then cut out.

STEP 6. Transfer the side panel edge and Haircalf cutting/placement patterns as shown on side panel insert cutting pattern to flesh side of lining repeat.

STEP 7. Apply cement to flesh sides of both lining pieces and to flesh sides of both Haircalf pieces. Locate the Haircalf placement area on lining and adhere Haircalf to lining. Apply cement to flesh sides of both side panels. Align edges of side panel with side panel edge pattern on lining leather, adhere. Repeat. Allow to dry completely and trim lining flush to side panel edges.

STEP 8. Using appropriate punch size, punch all holes through Haircalf and lining using pre-punched holes in both side panels as a guide.

STEP 9. Using 4 yds of thread, stitch around side panel insert (see stitching instructions). Repeat for other panel.

STEP 10. Attach small conchos to all 4 tabs and large conchos to side panels. **PROCEED TO BAG ASSEMBLY INSTRUCTIONS.**



Side Panel Edge

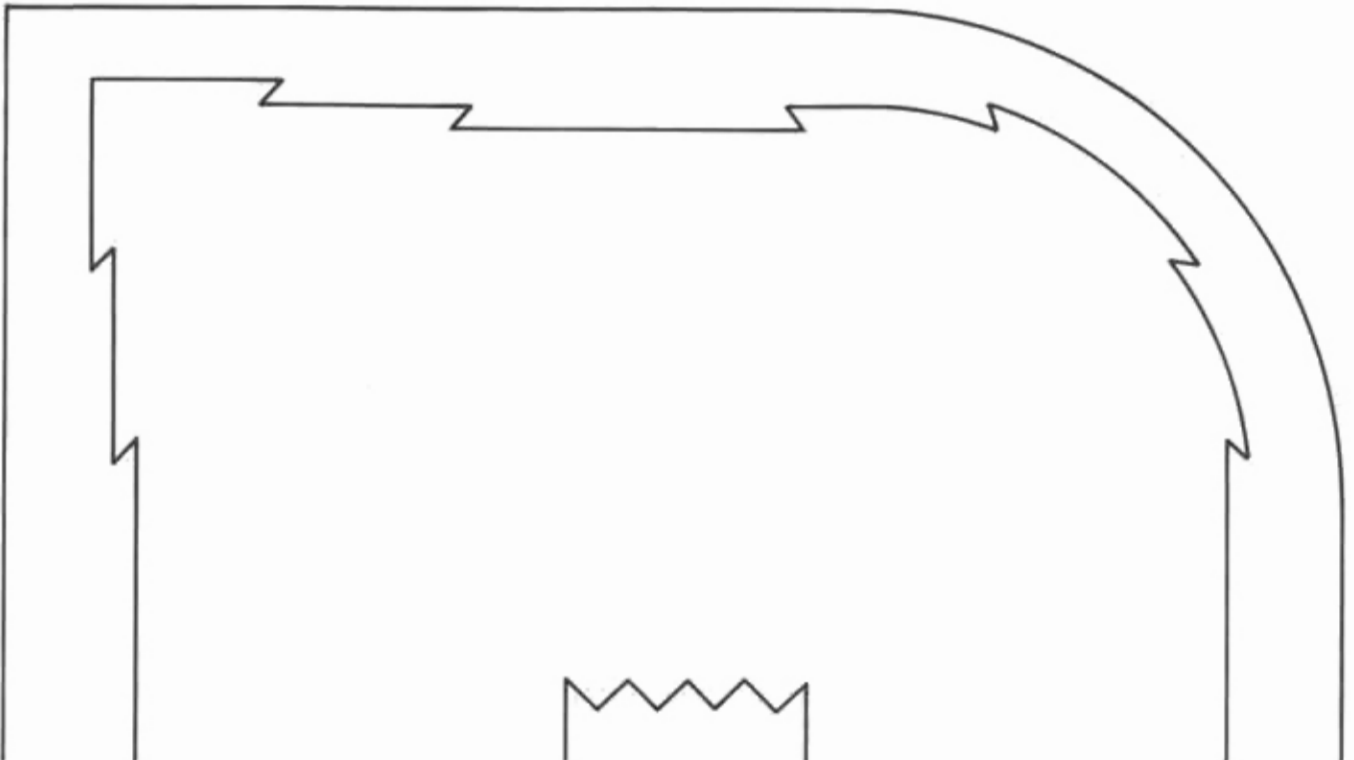

HAIRCALF INSERT PANEL ASSEMBLY
STEP 1. Use tracing paper and stylus to trans-

FOR INITIAL(S)



Use this Wild R
design comple
various parts of
your



LEATHER STITCHING INSTRUCTIONS

Lead one end of waxed thread through 1" needle and pull about 1" through. End around thread and twist between s. Push needle through first hole in lace only, leaving about 1" tail of 1 between the pieces of leather. Stitch through second hole in both pieces of r and up through third hole. Continue ng in this manner to last hole, pulling stitch tight.

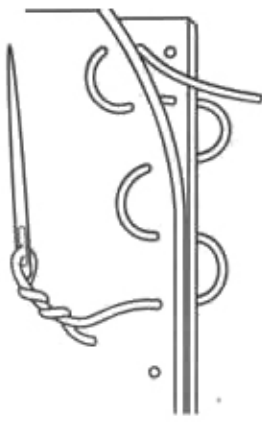

E - For a more professional look when in the stitches; from one side, put the e through the hole above the previ- stitched thread. From the other side, e needle through the hole below the usly stitched thread. Continue stitch- this manner.

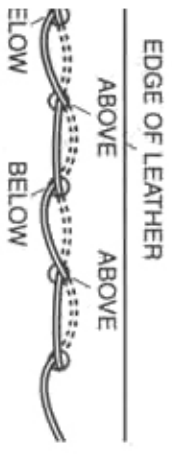

2 When you reach the last hole, turn and begin stitching back to starting point, filling in alternate stitches. Stitch to beginning hole.

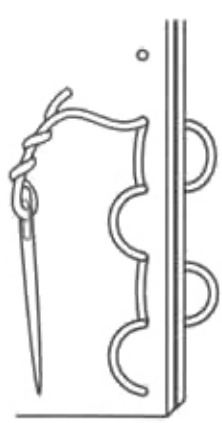

3 When you reach the beginning hole, go through hole in bottom piece only and bring needle up between the two pieces of leather. Tie end of thread to 1" tail left at beginning with a double knot. Pull knot down tight between the pieces of leather and trim off excess thread. Tap stitches down with a mallet.

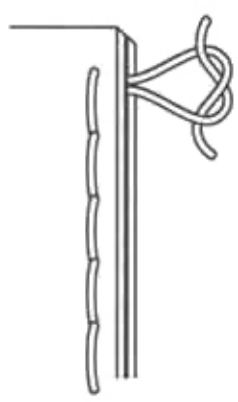

HOW TO THREAD THE 2-PRONG NEEDLE

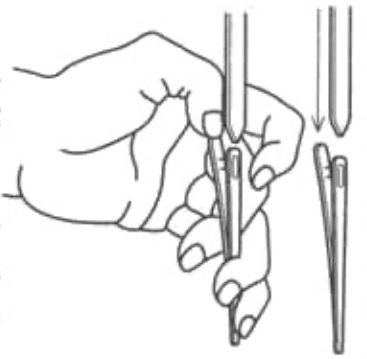

Point one end of lace, spring the thread- ing end of the needle open and insert the pointed end of the lace into the needle, smooth side of lace to prongs. Close nee- dle on lace and tap with a mallet so prongs pierce lace and lock in place. To remove lace, spring needle open as shown.

ALTERNATE ENDING - When you reach the beginning hole, go through hole in both pieces of leather and then stitch back through next 3 holes. Trim excess thread close to the leather on outside and tap stitches down with a mallet.

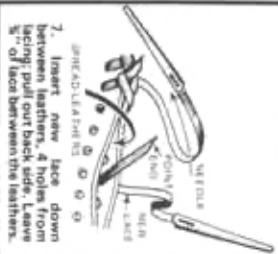
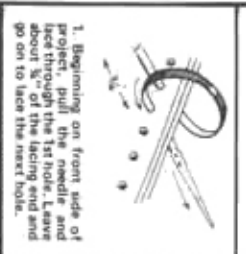
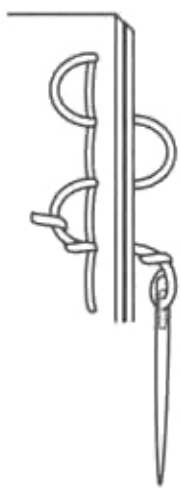

19. Lace under the tight. do not pull this stitch tight.

20. Careful show it down the.

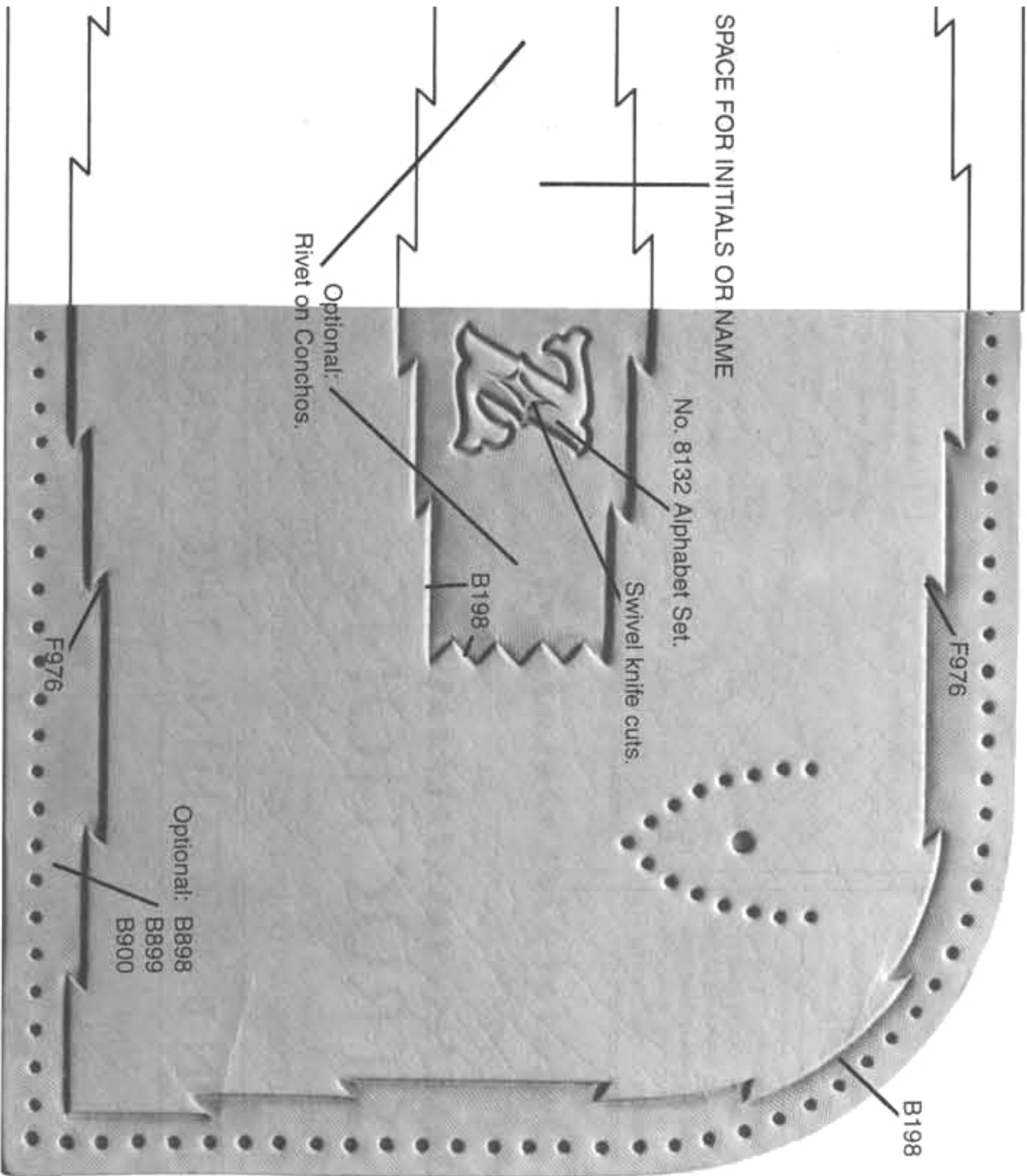

TASSEL ASSEMBLY

The Tassel should be added after tooling, dyeing and construction pleite. Because the tie is decorative functional a thread color which the Horsehair will add a designe

- 1 Cut one of three long an er 18" 1

- 2 Pinch about a 1/4" thickness horsehair. Measure 9" and clip, 1 make a 4" Tassel.

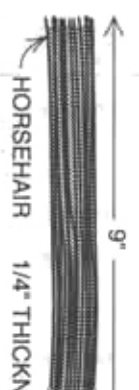

- 3 Put one end of horsehair through Zipper Pull. (If necessary wrap e tape.





Use and Basketweave
 te, as shown, or use
 the design to achieve
 own look.

X510



Swivel Knife Cuts

J820

H907

B893 Drag tip of
 tool along stems.

A888

P973

F978

B936

B701

J820











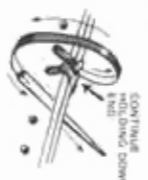







B936

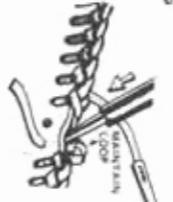

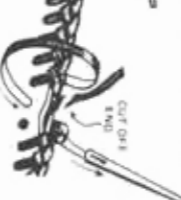
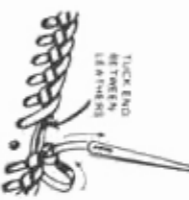
V920 pointing to the left.

Cent

HOW TO LACE & SPLICE THE DOUBLE LOOP STITCH

 <p>HOLD END OF LACE WITH FINGER</p>	 <p>CONTINUE DOWN</p>	 <p>PULL THE STITCH UNDER THE BIGHT</p>	 <p>FOLLOW THE SAME PROCEDURE AS IN STEPS 1 AND 2</p>	 <p>APPROXIMATELY 5"</p>
 <p>TUCK END BETWEEN LEATHERS</p>	 <p>PULL THE OLD LACE UP TIGHT</p>	 <p>TUCK END OF LACE BETWEEN LEATHERS</p>	 <p>CONTINUE LACING TO STARTING POINT</p>	 <p>TIE OFF LACING</p>
 <p>FRONT SIDE, PULL END OF LOOP</p>	 <p>PUSH TOOL OR NEEDLE DOWN BETWEEN LEATHERS</p>	 <p>PULL END OF LACE OUT OF HOLE</p>	 <p>CUT OFF END OF LACE</p>	 <p>TUCK END BETWEEN LEATHERS</p>
 <p>FULLY CROSS OVER AND PUSH NEEDLE THROUGH LOOP</p>	 <p>PULL NEEDLE THROUGH, PUSH LACED EDGES TOGETHER</p>	 <p>PULL ANY SLACK OUT OF FIRST LOOP</p>	 <p>PULL END OF LACING DOWN TIGHT</p>	 <p>PUSH NEEDLE THROUGH LAST HOLE</p>

Y

er all
is com-
live and
contrasts
er touch.

e length
ad 6"
nd anoth-
long.

of
this will

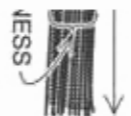

ough
and with

SESHAIR

4 Pull about halfway through the Zipper Pull. Fold ends over, end should be even.



5 Using the 6" length of thread, tie the horsehair together just below the Zipper Pull, clip ends.



6 Using the 18" length of thread, form a Loop with one end.

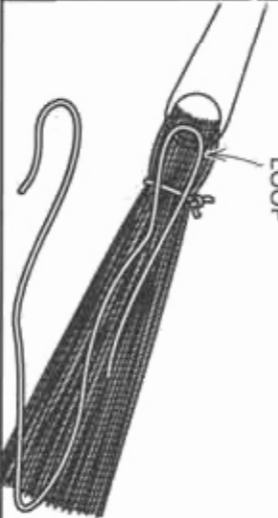

7 About 3/4" from Zipper Pull. Cross B over A. Wrap all the way around Horsehair.

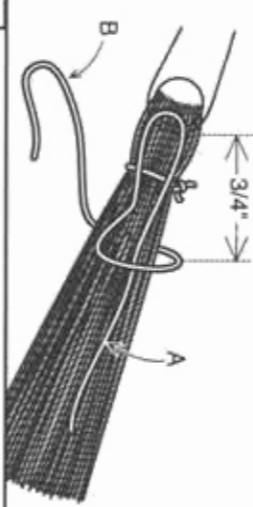

8 Pull each wrap tight. Continue to wrap toward the loop. Cut off the tie (from step 5). Wrap about 12 times.

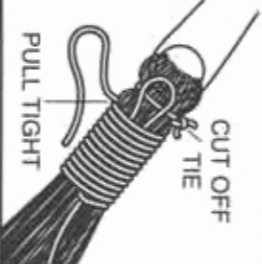

9 Pull end A slowly to where the thread B is pulled under the wrapped area. (to the middle). Clip ends. Trim ends of Horsehair even.

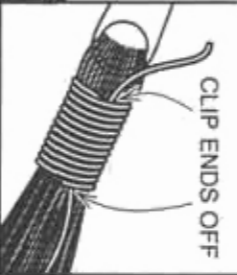

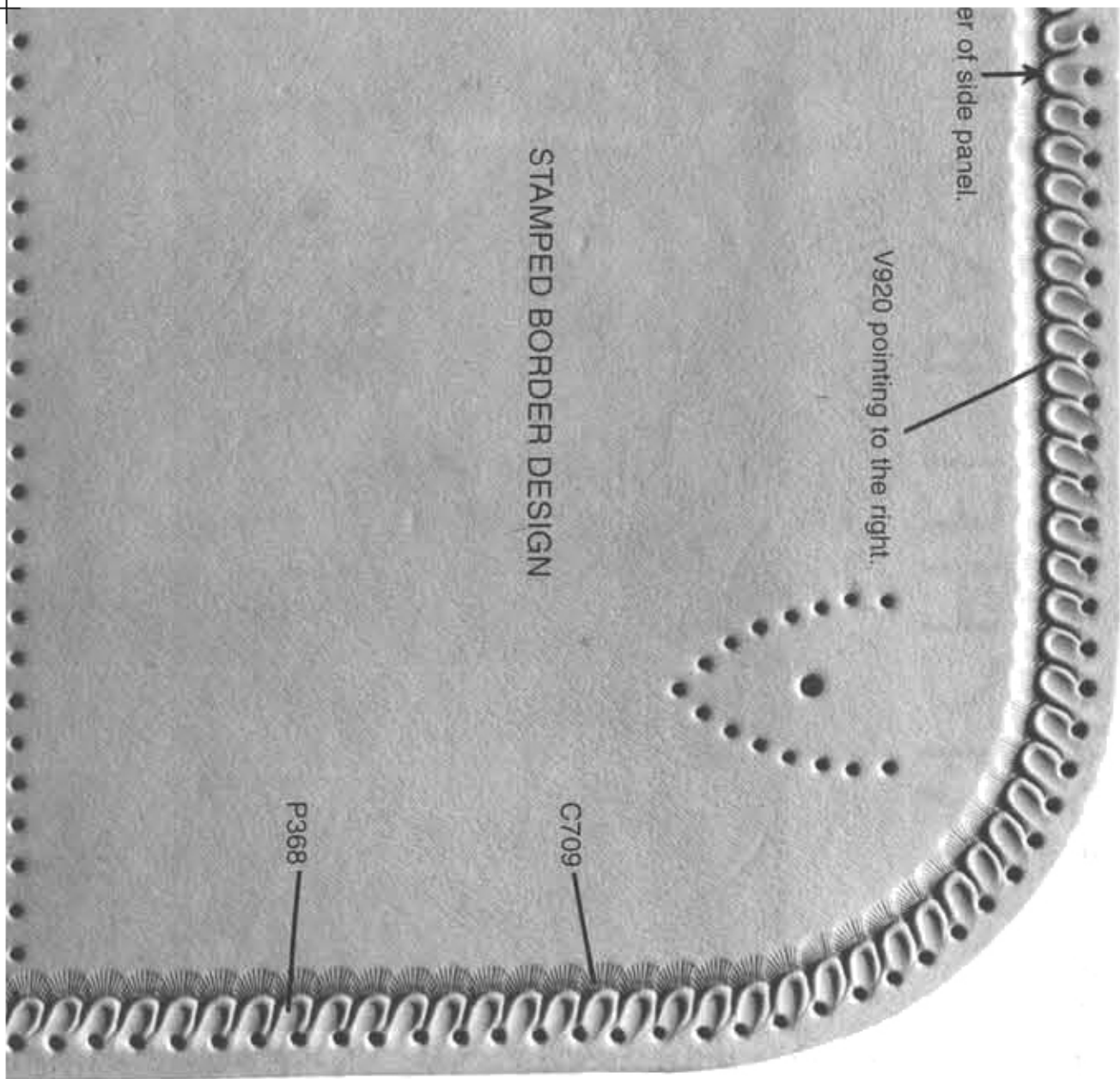

er of side panel.

V920 pointing to the right.

STAMPED BORDER DESIGN

C709

P368