

# Vintage Pattern Series

## Stohlman Quiver and Arm Guard Pattern



**LeathercraftLibrary.com**  
DIGITAL MEDIA FOR LEATHERCRAFTERS



## Pattern Digital Download

This PDF file contains 1 (one) full pattern package. The PDF has been put together to give you options when it comes to printing. Pages and patterns that are larger than 8½x11 have been provided in two formats:

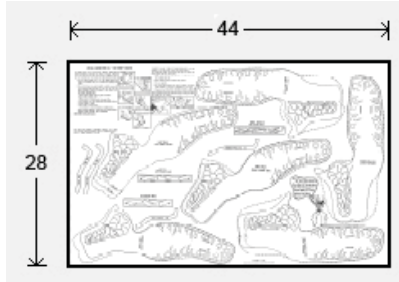

### 1) Full Size

If you would like to have a full size print out, take the full size pages to your local print shop and they can print it for you.

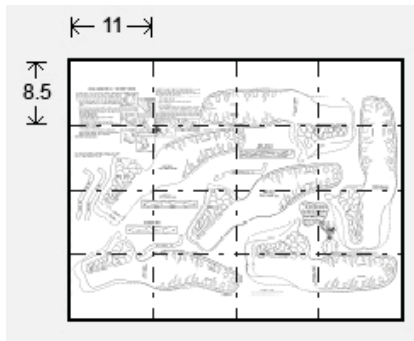

### 2) Tiled

The tiled pages give you the option of printing the larger patterns at home. You print the tiled pages and then assemble them to make the larger patterns.

The pattern PDF files are typically laid out like this:

Cover(if applicable), instructions sheets (if applicable), pattern 1 – full sized, pattern 1 – tiled, pattern 2 – full sized, pattern 2 – tiled, pattern 3 – full sized, pattern 3 – tiled ....etc

Please note: When printing on a home printer, use the settings seen on the image to the right in the Page Handling area of the Adobe Reader print dialogue box. If your printer is cutting edges off, set “Page Scaling” to “Shrink to Printable Area”. This will, however, decrease the size of the pattern a very small amount.

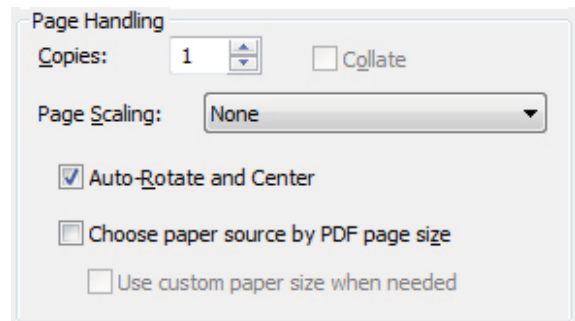

You may take this PDF file to your local print shop to have the full-size pages printed for your own personal use.



# QUIVER and ARM GUARD

# Craftaid No. 3089



COMPLETE TEMPLATE  
INSTRUCTIONS ENCLOSED.

198 571  
BEVELERS



# ASSEMBLY INSTRUCTIONS

FULL SIZE PHOTO PATTERNS ENCLOSED

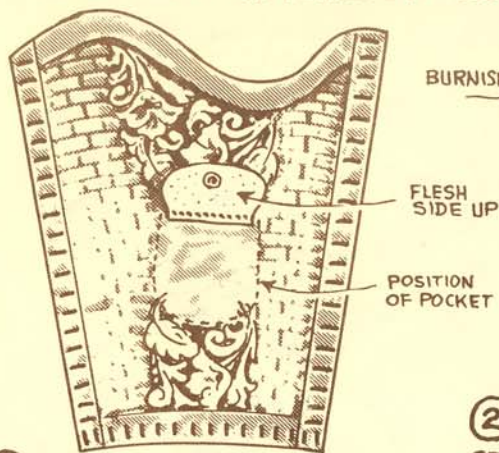

① AFTER STAMPING THE DESIGNS.... CEMENT EDGE OF POCKET FLAP TO QUIVER IN POSITION SHOWN ON THE ENCLOSED PHOTO PATTERN. LACE OR SEW IN PLACE AS SHOWN ABOVE.

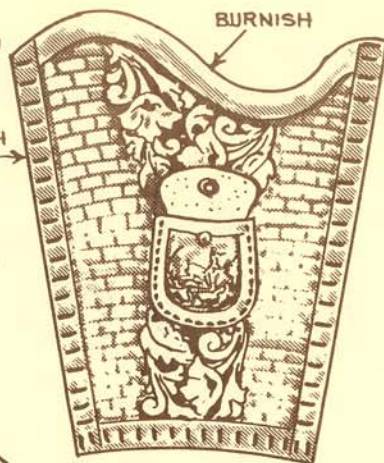

② CEMENT POCKET IN POSITION AND SEW OR LACE TO QUIVER WITH A RUNNING STITCH AS SHOWN ABOVE. EDGE AND BURNISH TOP—AND THE LEFT SIDE OF QUIVER.

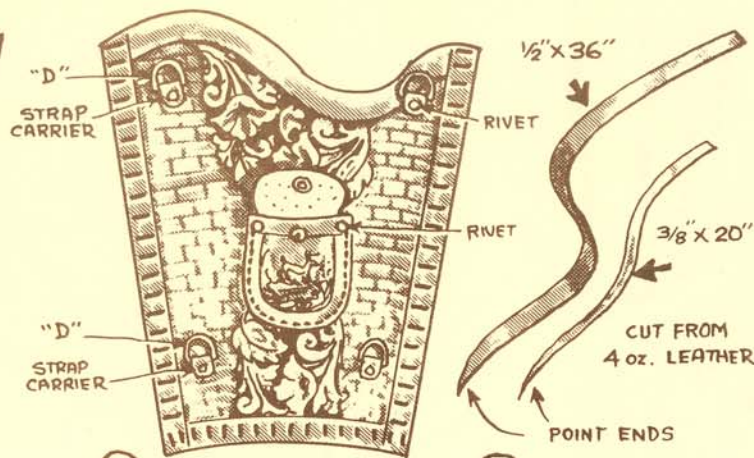

③ RIVET POCKET CORNERS FOR ADDED STRENGTH. ALSO RIVET "D'S" TO THE QUIVER... PATTERNS FOR STRAP CARRIERS ON THE ENCLOSED SHEET.

④ FROM 3½ OR 4 oz. LEATHER... CUT TWO STRIPS AS INDICATED ABOVE. POINT ONE END FOR EASIER LACING.

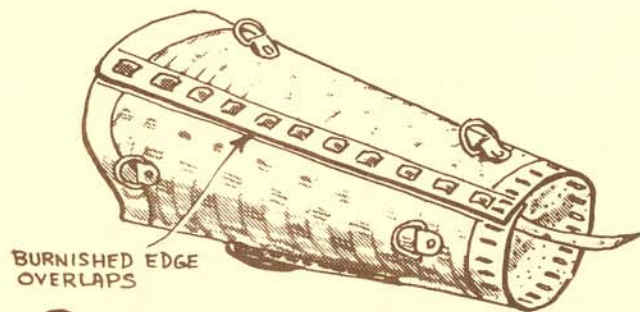

⑤ FOLD QUIVER.... OVERLAP SIDES AND ALIGN SLOTS. USE ½" STRIP, BEGIN AT TOP AND LACE THRU SLOTS WITH A RUNNING STITCH, AS SHOWN.

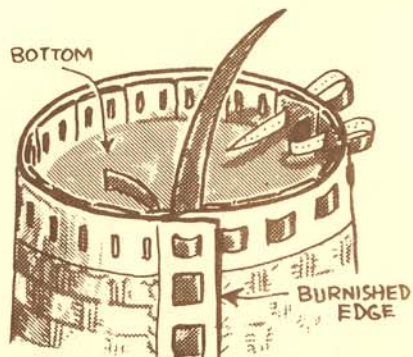

⑥ PUSH BOTTOM INTO PLACE THRU TOP OF QUIVER, ALIGN LACING SLOTS AND LACE WITH ¾" STRIP,... BEGINNING AS SHOWN. COMPLETE LACING AND CUT OFF ENDS.

**IMPORTANT!**  
BE SURE TO STUDY THE ENCLOSED INSTRUCTION SHEET.... BEFORE BEGINNING TO MAKE THE QUIVER.

⑦ APPLY LEATHER DRESSING AND ATTACH SHOULDER STRAPS AS SHOWN ON THE ENCLOSED INSTRUCTION SHEET.

LIST OF CRAFTTOOLS USED... IN ORDER SHOWN.  
PATTERN NUMBER  
**3089**

B971 B198 V821 P209 S632 H907 V853 A104 F899 X534 D436

SECTION "C"

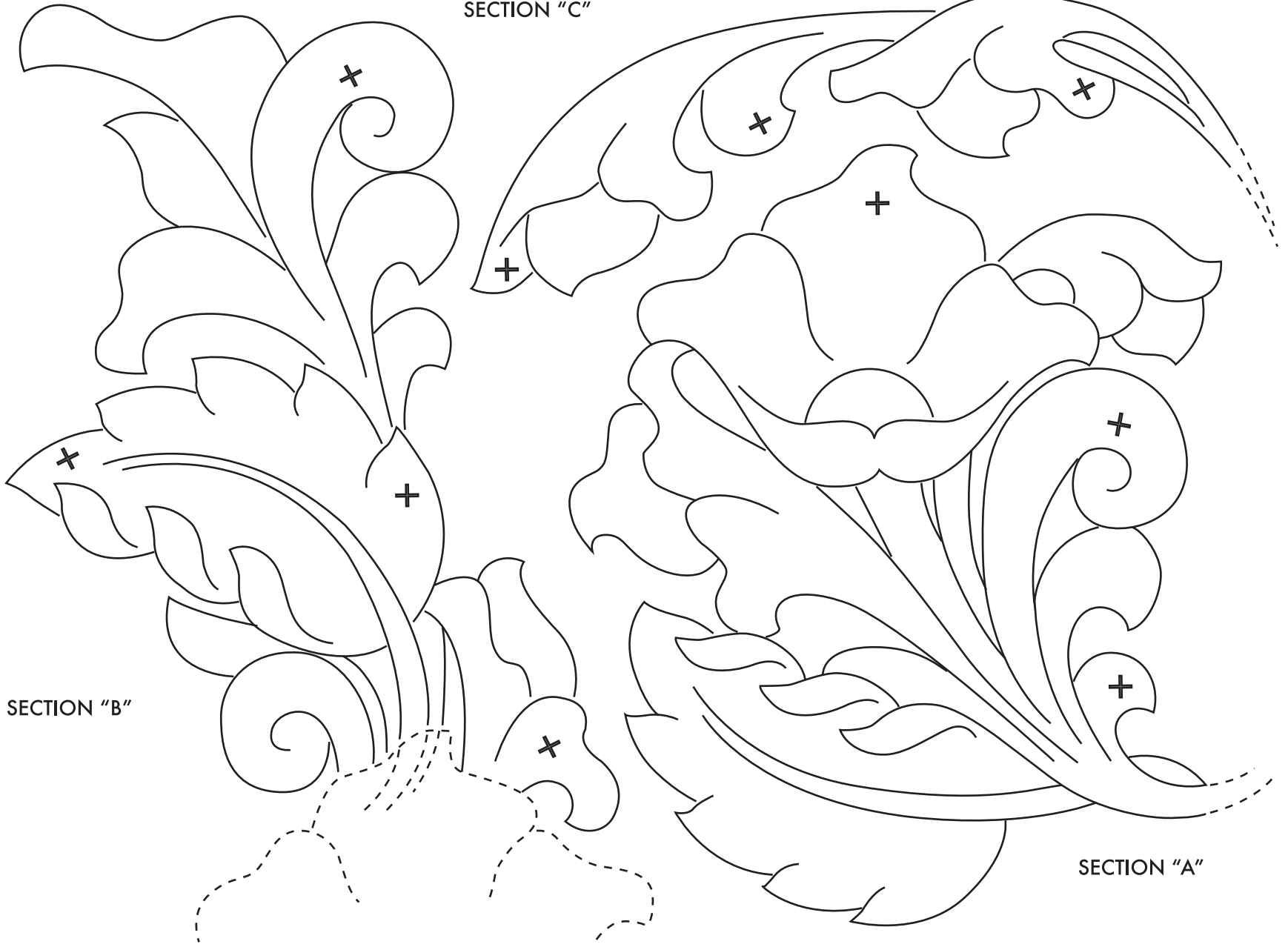

SECTION "B"

SECTION "A"



**ASSEMBLY INSTRUCTIONS ON ENVELOPE**

**Craftaid No. 3089**

**QUIVER PATTERN**



1/2" BAG PUNCH  
SPACE SLOTS 1/2" APART

1/2" BAG PUNCH  
SPACE SLOTS 1/2" APART

"REGISTRATION MARKS"  
SEE HOW TO USE  
TEMPLATE BELOW

POSITION OF  
RIVET HOLE  
SEE ASSEMBLY  
INSTRUCTIONS  
ON ENVELOPE

POSITION OF  
RIVET HOLE  
SEE ASSEMBLY  
INSTRUCTIONS  
ON ENVELOPE

**HOW TO USE THE TEMPLATE**

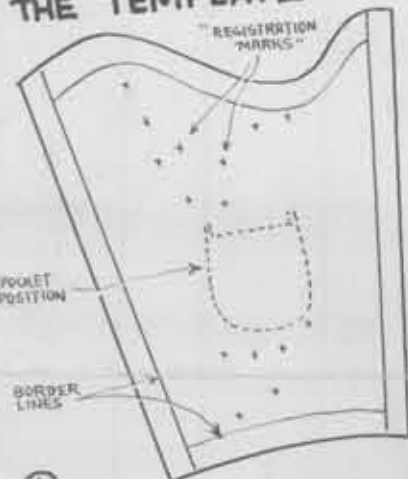

1 AFTER CUTTING AND CASING THE LEATHER... MARK THE BORDER LINES — POSITION OF POCKET (dotted lines) — AND CAREFULLY MARK POSITIONS OF "REGISTRATION MARKS" IN EXACT POSITIONS SHOWN ON PHOTO PATTERN AT RIGHT.



2 ALIGN "REGISTRATION MARKS" OF TEMPLATE WITH MARKS ON LEATHER AND RUB THAT SECTION OF DESIGN CORRESPONDING WITH TEMPLATE SECTION AS INDICATED ON PHOTO PATTERN.



3 KEEP THE PHOTO PATTERN HANDY TO AID IN ALIGNING THE CORRECT TEMPLATE SECTION. AFTER DESIGN HAS BEEN TRANSFERRED TO LEATHER, CARVE AND STAMP. USE THE PHOTO PATTERN AS YOUR GUIDE.

POSITION OF  
RIVET HOLE  
SEE ASSEMBLY  
INSTRUCTIONS  
ON ENVELOPE

548  
ALTERNATE TOOL SUGGESTION FOR STAMPING PLAIN AREAS. BEGIN STAMPING IN CORNER... LEFT TO RIGHT.

3/8" BAG PUNCH  
SPACE SLOTS 1/2" APART

**POCKET**  
POCKET MUST BE CUT FROM SEPARATE LEATHER... DO NOT CUT POCKET DESIGN ON QUIVER.  
ALTERNATE POCKET AND POCKET FLAP PATTERN ON THE REVERSE SIDE.

FULL SIZE PATTERNS for:

- POCKET
- POCKET FLAP
- BOTTOM
- ARM GUARD
- SHOULDER STRAPS

ON REVERSE SIDE

BASKET STAMP SIDES TO RELIEVE PLAINNESS, IF DESIRED. BEGIN STAMPING IN CORNER... STAMP UPWARDS.

POSITION OF  
RIVET HOLE  
SEE ASSEMBLY  
INSTRUCTIONS  
ON ENVELOPE

**PHOTO PATTERN AND CUTTING PATTERN OUTLINE**

CUT FROM 8-9 oz. LEATHER

ASSEMBLY INSTRUCTIONS ON ENVELOPE

NOTE: SKIVE ABOUT 1/8" THICKNESS OFF FLESH SIDE OF THIS CORNER ONLY. (shaded)



**ASSEMBLY  
INSTRUCTION  
ON ENVELOPE**

TEMPLATE  
SECTION "A"

**1/2" BAG PUNCH**  
SPACE SLOTS 1/2" APART

**"REGISTRATION MARKS"**  
SEE HOW TO USE  
TEMPLATE BELOW

POSITION OF  
RIVET HOLE  
SEE ASSEMBLY  
INSTRUCTIONS  
ON ENVELOPE

**HOW TO USE  
THE TEMPLATE**

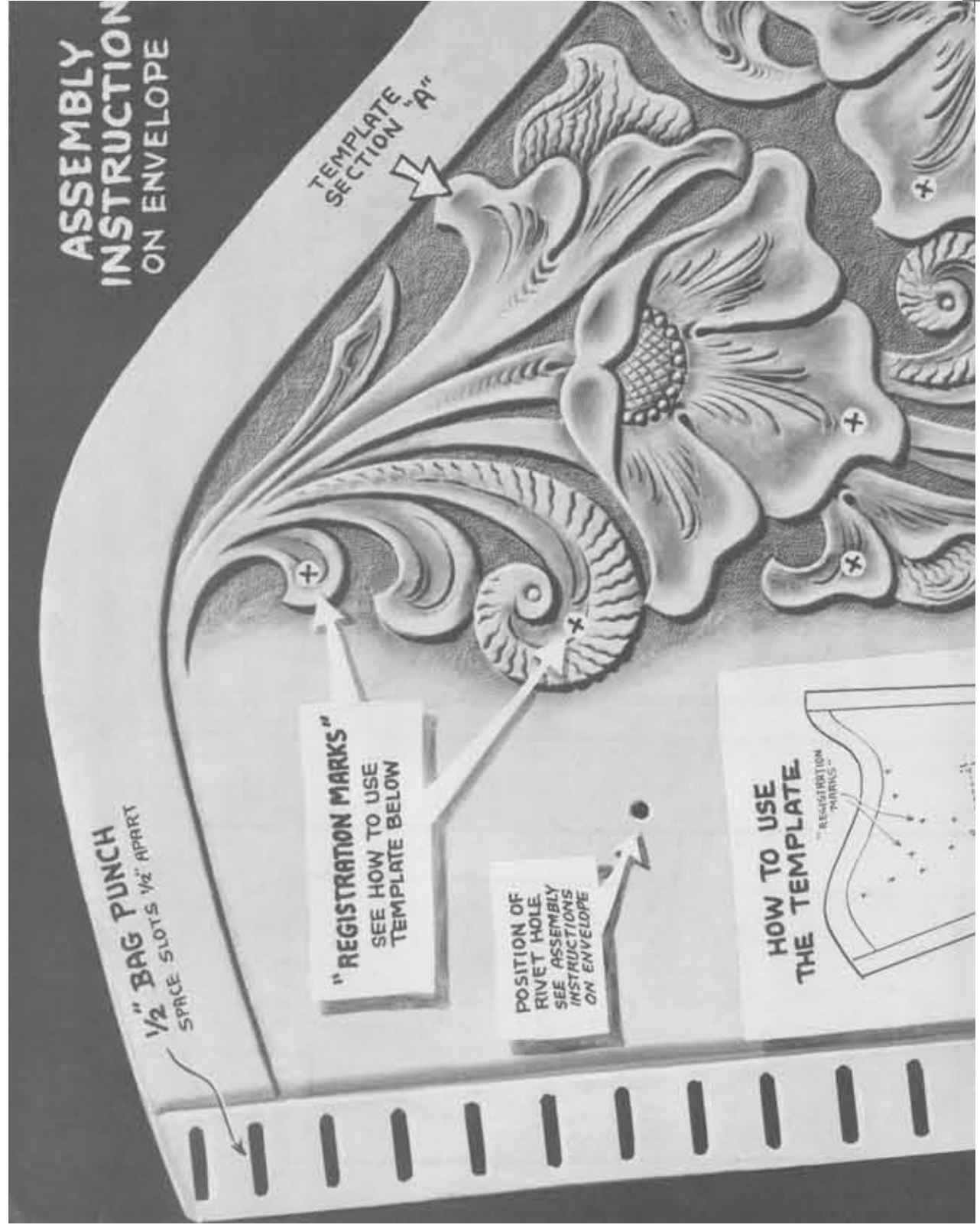

S

# Craftaid No. 3089

## QUIVER PATTERN



TEMPLATE  
SECTION "A"

1/2" BAG PUNCH  
SPACE SLOTS 1/2" APART

POSITION OF  
RIVET HOLE  
SEE ASSEMBLY  
INSTRUCTIONS  
ON ENVELOPE.



① AFTER CUTTING AND CASING THE LEATHER... MARK THE BORDER LINES — POSITION OF POCKET (dotted lines) — AND CAREFULLY MARK POSITIONS OF "REGISTRATION MARKS" IN EXACT POSITIONS SHOWN ON PHOTO PATTERN AT RIGHT.



② ALIGN "REGISTRATION MARKS" OF TEMPLATE WITH MARKS ON LEATHER AND RUB THAT SECTION OF DESIGN CORRESPONDING WITH TEMPLATE SECTION AS INDICATED ON PHOTO PATTERN.



TEMPLATE SECTION "B"



POSITION TO CEMENT POCKET TO QUIVER

POS PO

DEE CRAF



POSITION TO CEMENT  
POCKET FLAP TO QUIVER.

CUT FROM  
PATTERN NO. 2910

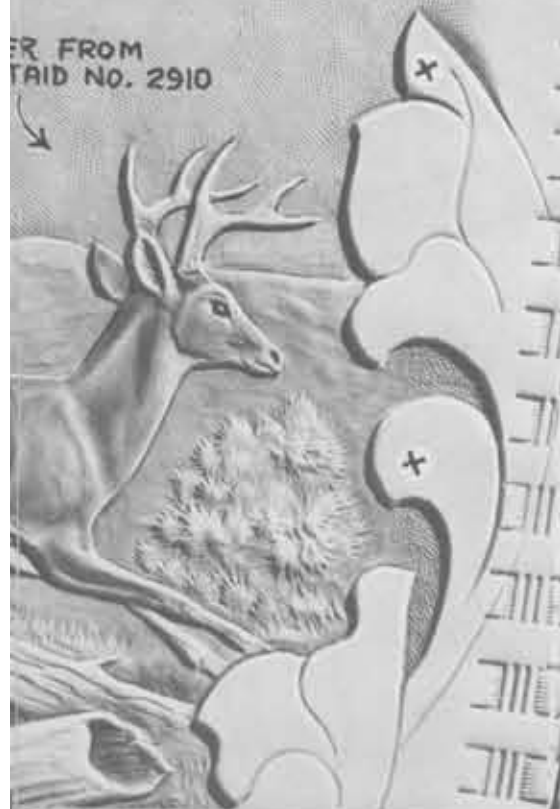

### POCKET

POCKET MUST BE  
CUT FROM SEPERATE  
LEATHER... DO NOT  
CUT POCKET DESIGN  
ON QUIVER.

ALTERNATE POCKET  
AND POCKET FLAP  
PATTERN ON THE  
REVERSE SIDE.

FULL SIZE  
PATTERNS

for:

● POCKET

● POCKET FLAP



**PHOTO  
PATTERN  
AND  
CUTTING  
PATTERN  
OUTLINE**

CUT FROM 8-9 oz.  
LEATHER

#  
ASSEMBLY  
INSTRUCTIONS  
ON ENVELOPE

KEEP THE PHOTO PATTERN HANDY  
TO AID IN ALIGNING THE CORRECT  
TEMPLATE SECTION. AFTER DESIGN  
HAS BEEN TRANSFERRED TO LEATHER,  
CARVE AND STAMP. USE THE PHOTO  
PATTERN AS YOUR GUIDE.

POSITION OF  
RIVET HOLE  
SEE ASSEMBLY  
INSTRUCTIONS  
ON ENVELOPE

548

ALTERNATE TOOL  
SUGGESTION FOR  
STAMPING PLAIN  
AREAS. BEGIN  
STAMPING IN  
CORNER... LEFT  
TO RIGHT.

$\frac{3}{8}$ " BAG PUNCH  
SPACE SLOTS  $\frac{1}{2}$ " APART

TEMPLATE SECTION

TEMPLATE SECTION "B"

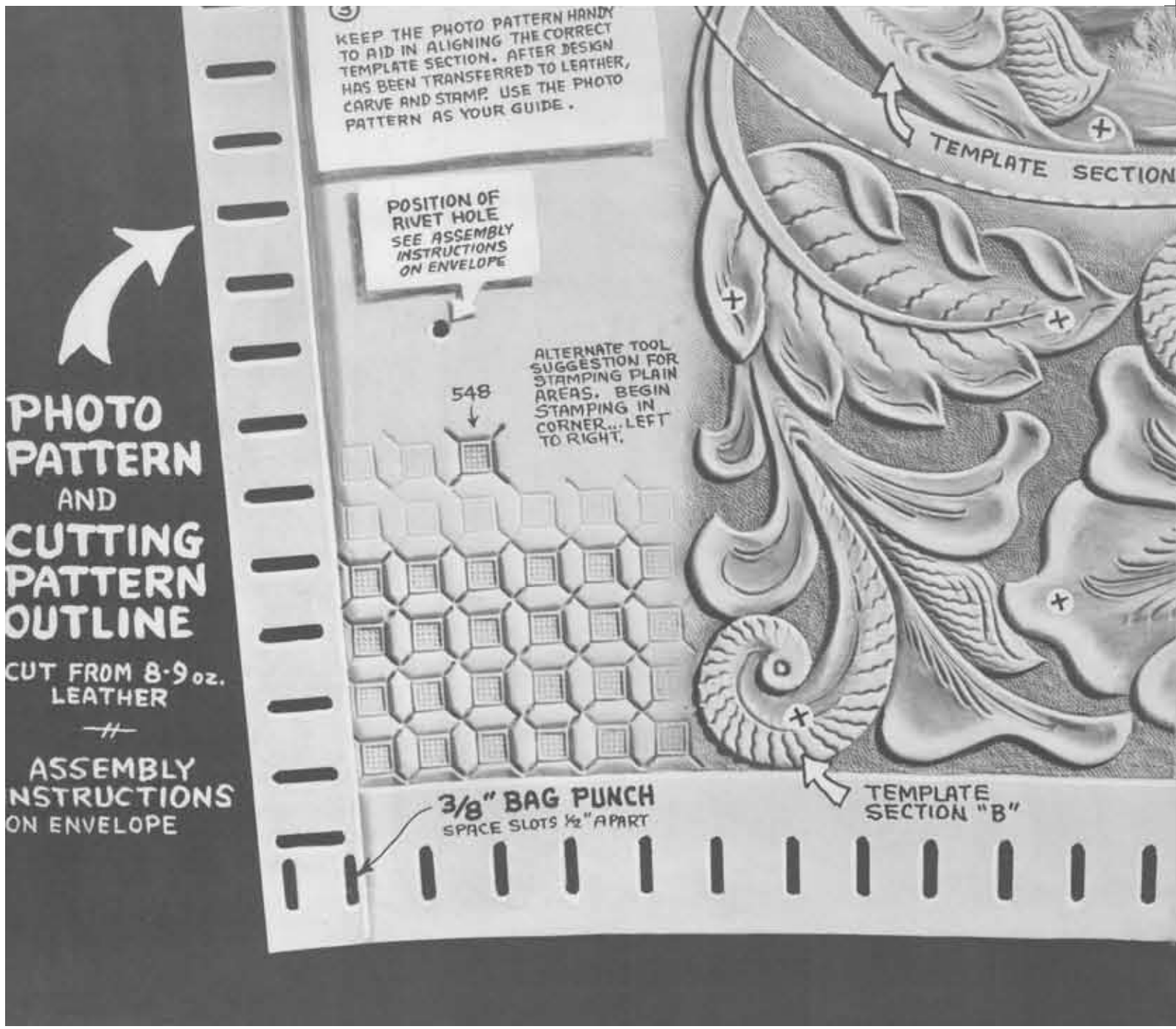

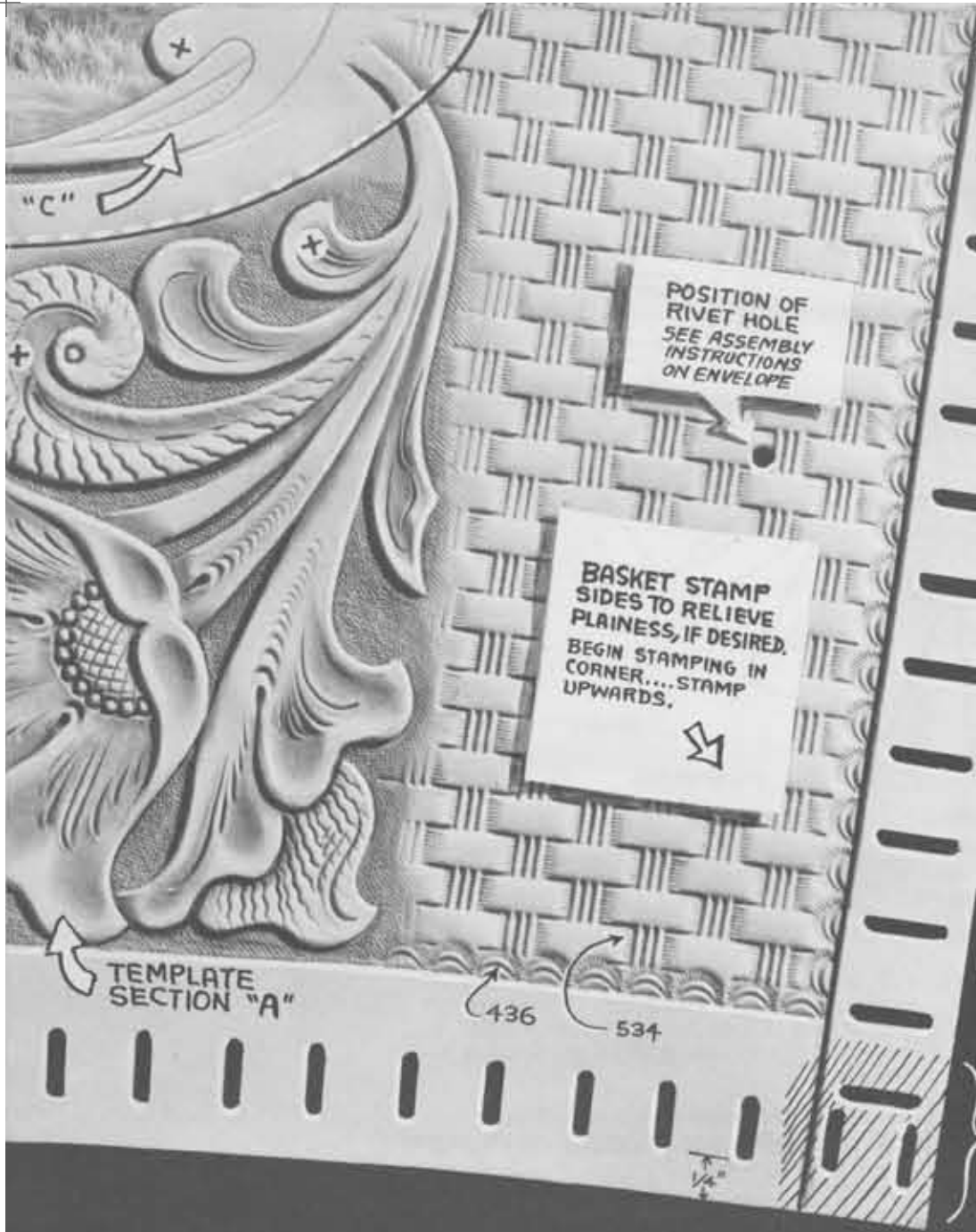

- BOTTOM
- ARM GUARD
- SHOULDER STRAPS

ON REVERSE SIDE

POSITION OF RIVET HOLE  
SEE ASSEMBLY INSTRUCTIONS  
ON ENVELOPE

BASKET STAMP  
SIDES TO RELIEVE  
PLAINNESS, IF DESIRED.  
BEGIN STAMPING IN  
CORNER... STAMP  
UPWARDS.



← **NOTE :**  
SKIVE ABOUT 1/2 THICKNESS  
OFF FLESH SIDE OF THIS  
CORNER ONLY. (*shaded*)



**ARM GUARD**

(MAKE ONE)  
CUT FROM 5-6 oz. LEATHER

USE 5/8" SKATE STRAP BUCKLES (3 REQUIRED)

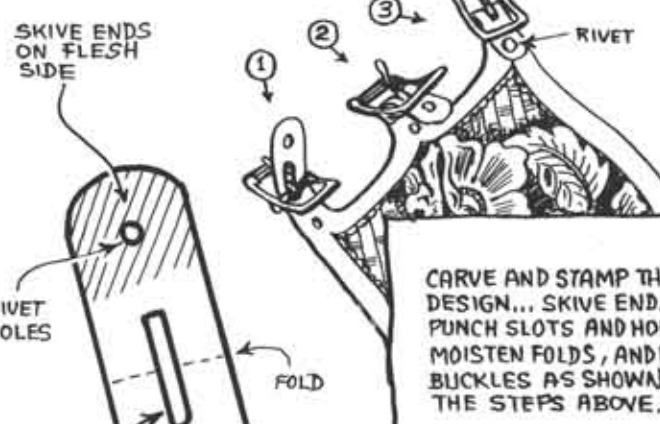

CARVE AND STAMP THE DESIGN... SKIVE ENDS... PUNCH SLOTS AND HOLES... MOISTEN FOLDS, AND RIVET BUCKLES AS SHOWN IN THE STEPS ABOVE.

5/8" BAG PUNCH

RIVET HOLES

FOLD

TEMPLATE SECTION "B"

REGISTRATION MARKS

TEMPLATE SECTION "A"

NOTE:  
SEE PHOTO PATTERN ON REVERSE SIDE FOR "HOW TO USE" THE TEMPLATE AND REGISTRATION MARKS!

SPACE ADJUSTMENT HOLES 1/4" APART

SKIVE TIPS ON FLESH SIDE

**BOTTOM**  
(MAKE ONE)  
CUT FROM 6 oz. LEATHER

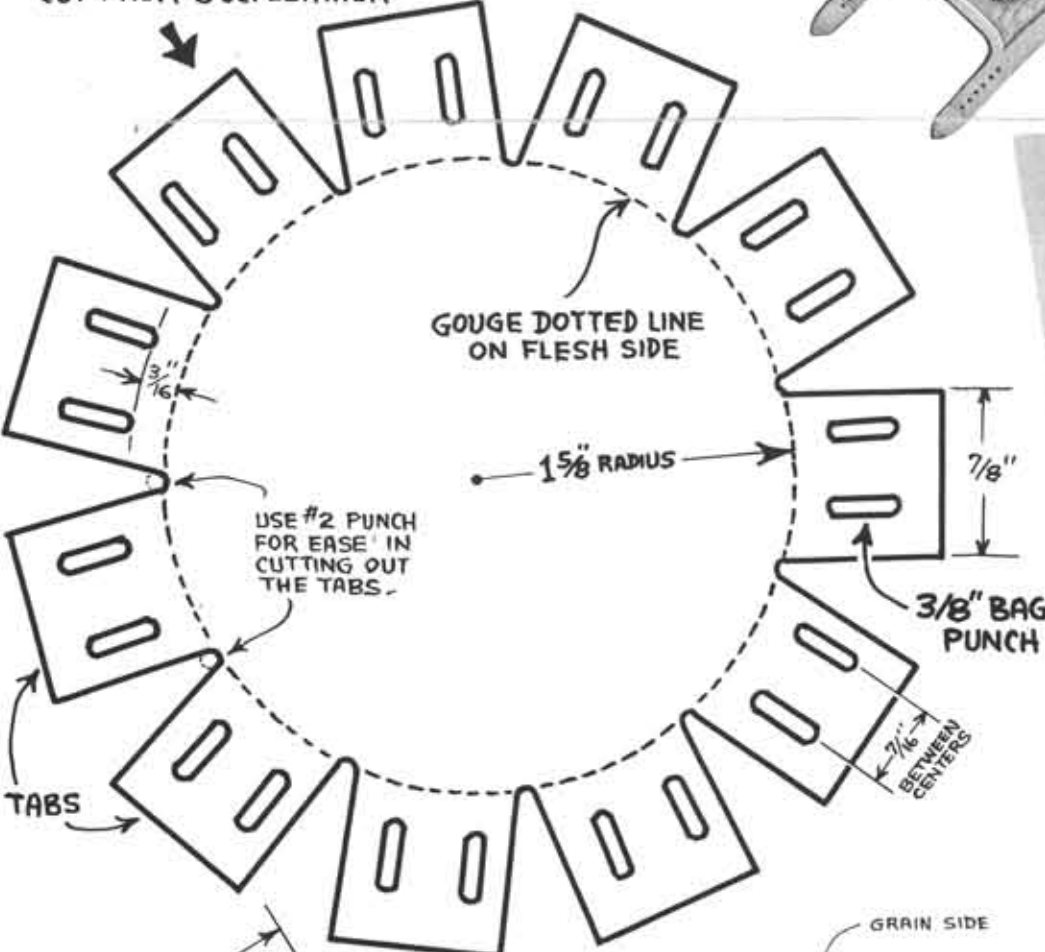

GOUGE DOTTED LINE ON FLESH SIDE

1 5/8" RADIUS

7/8"

3/8" BAG PUNCH

USE #2 PUNCH FOR EASE IN CUTTING OUT THE TABS.

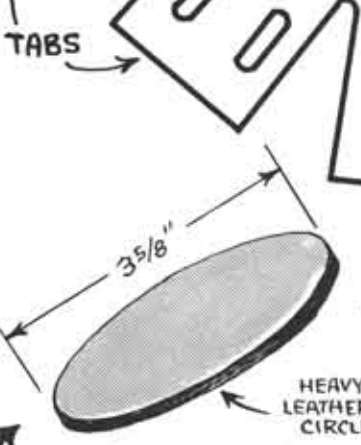

NOTE:  
1/4" PLYWOOD CIRCLE MAY BE USED IN PLACE OF LEATHER.

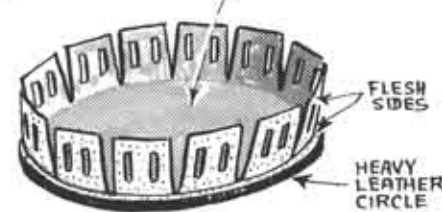

CUT BOTTOM OUT AS SHOWN. MOISTEN GOUGE AND FOLD TABS UP. CEMENT FLESH SIDE OF BOTTOM TO FLESH SIDE OF HEAVY LEATHER CIRCLE AS SHOWN ABOVE.

BOTTOM IS READY TO INSTALL.  
SEE ASSEMBLY INSTRUCTIONS ON ENVELOPE!

**POCKET FLAP**  
(MAKE ONE)  
CUT FROM 6 oz. LEATHER

USE DURABLE DOT SNAPS ON POCKET AND FLAP

**POCKET**  
(MAKE ONE)  
CUT FROM 6 oz. LEATHER

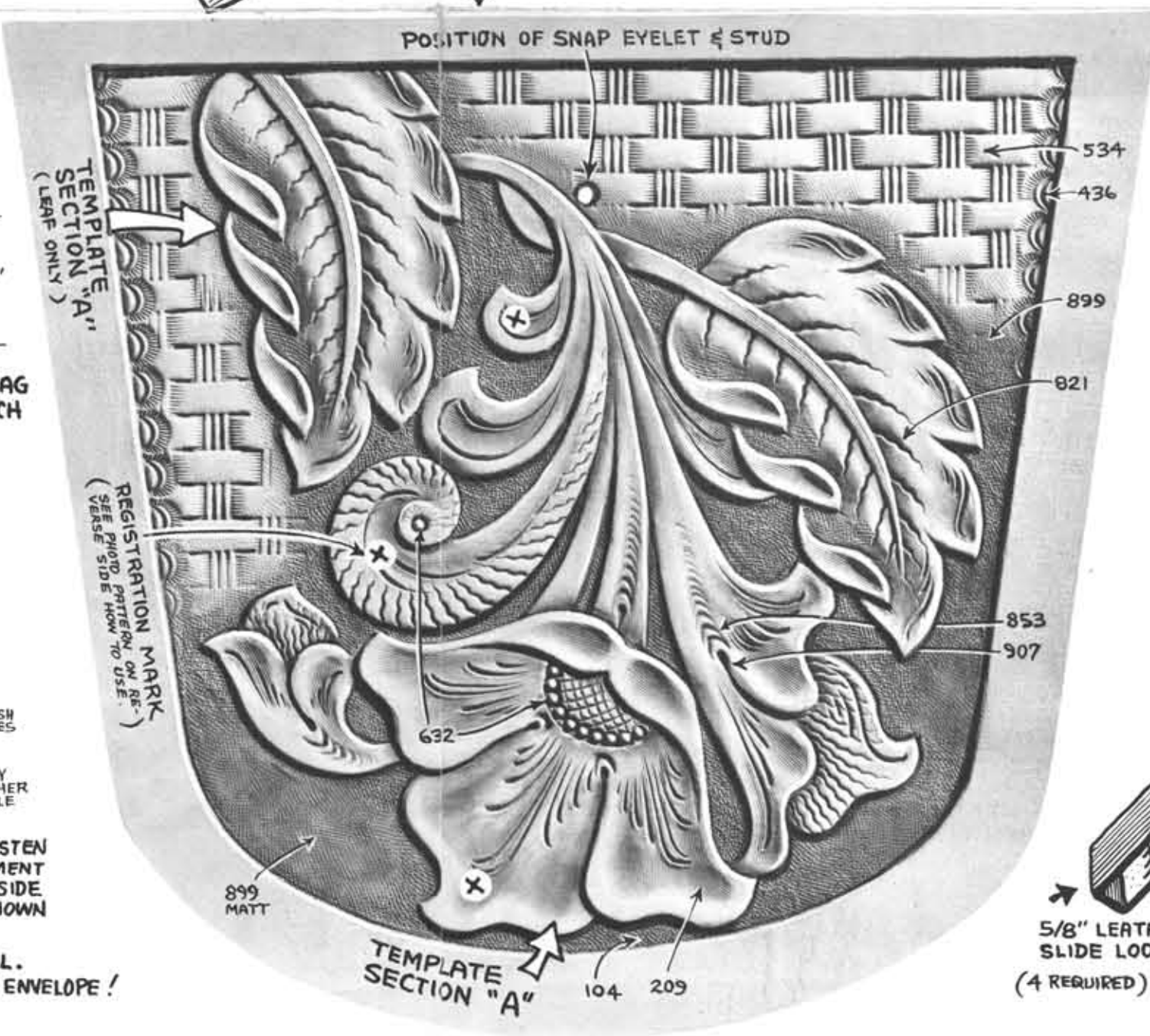

POSITION OF SNAP EYELET & STUD

TEMPLATE SECTION "A" (LEAF ONLY)  
REGISTRATION MARK (SEE PHOTO PATTERN ON REVERSE SIDE FOR HOW TO USE)

534

436

899

821

853

907

632

899 MATT

TEMPLATE SECTION "A"

104

209

**SHOULDER STRAP**

(MAKE TWO)  
CUT FROM 6 oz. LEATHER

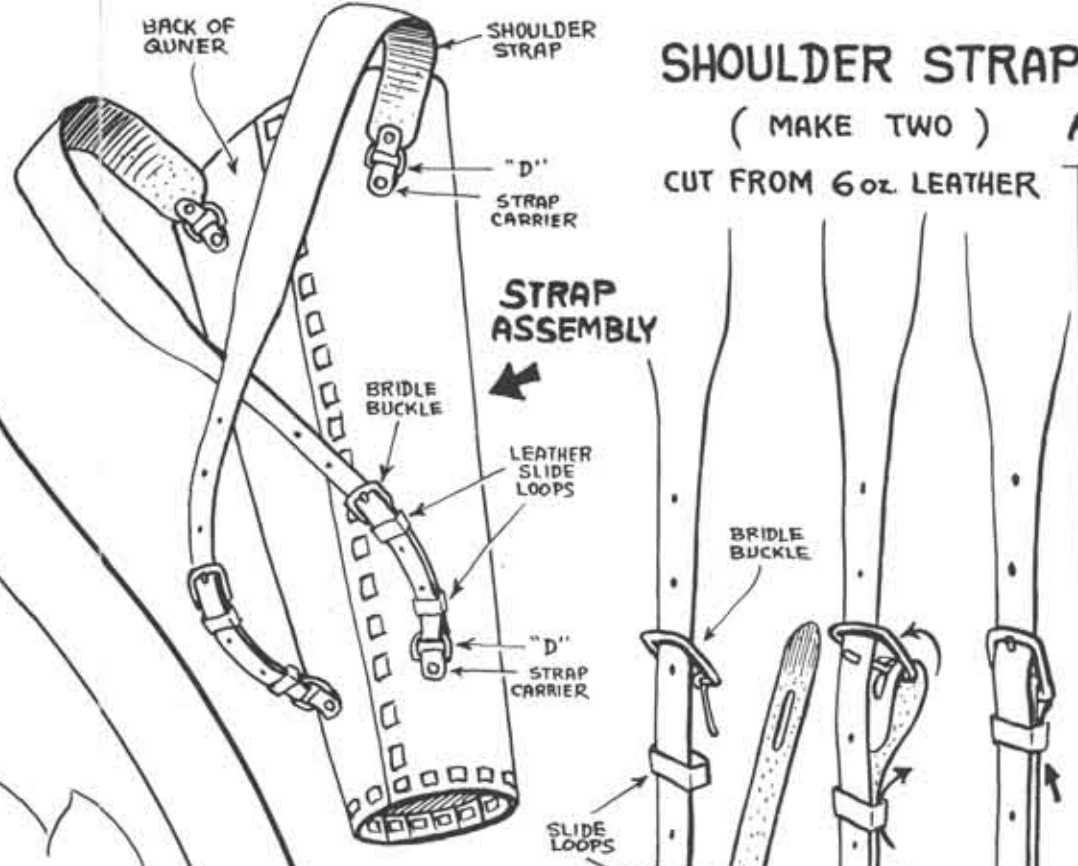

STRAP ASSEMBLY

BUCKLE AND LOOP ASSEMBLY OF SHOULDER STRAP

TO ADJUST LENGTH... LOOSEN LOOP AND PUT BUCKLE TONGUE IN DESIRED HOLE.

3/4" "D"

STRAP CARRIERS  
CUT FROM 4 oz. LEATHER

1 3/4"



4 REQUIRED

3/4"

RIVET HOLES

4 REQUIRED

SKIVE ENDS ON FLESH SIDE

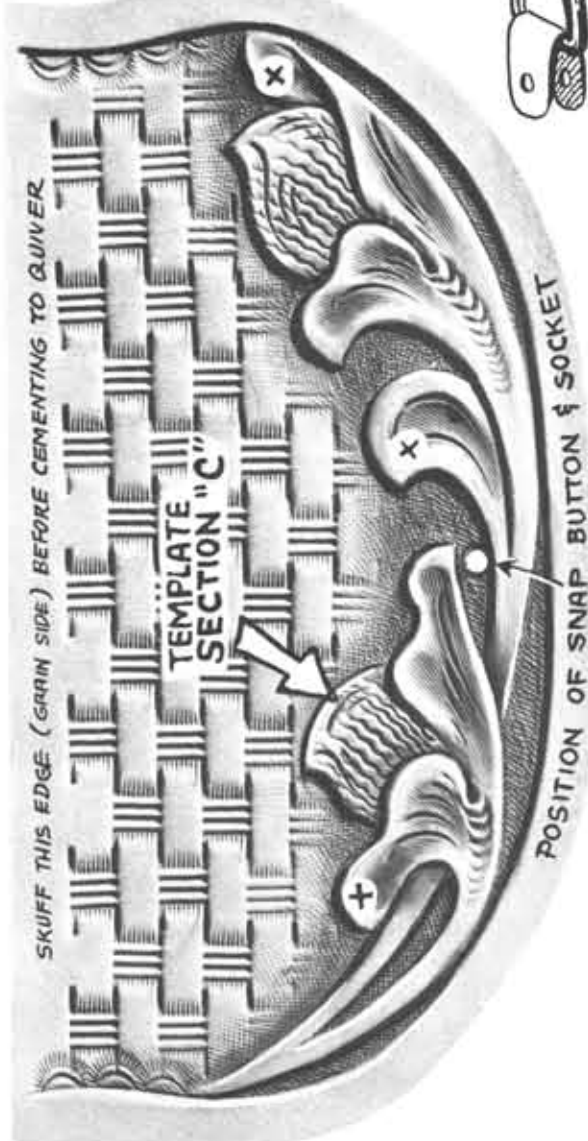

SKUFF THIS EDGE (GRAIN SIDE) BEFORE CEMENTING TO QUIVER

TEMPLATE SECTION "C"

POSITION OF SNAP BUTTON & SOCKET

ADJUSTMENT HOLES #3 PUNCH

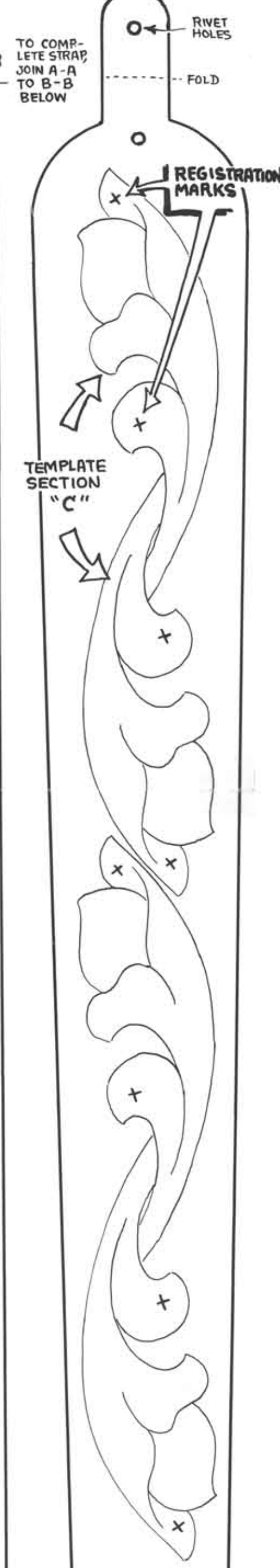

TEMPLATE SECTION "C"

REGISTRATION MARKS

TO COMPLETE STRAP, JOIN A-A TO B-B BELOW

RIVET HOLES  
FOLD

A B  
JOIN A-A AND B-B TO COMPLETE PATTERN

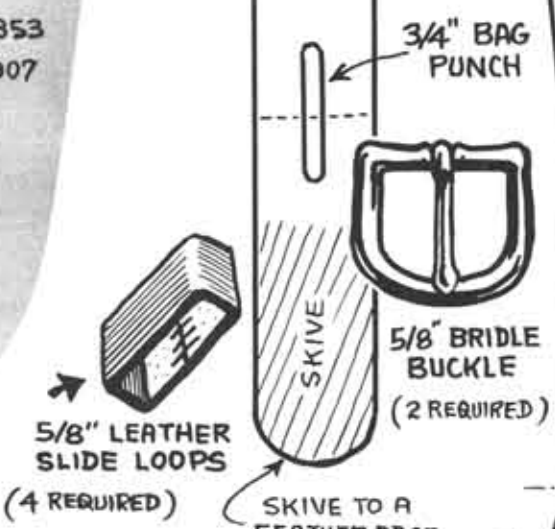

5/8" LEATHER SLIDE LOOPS (4 REQUIRED)

3/4" BAG PUNCH  
5/8" BRIDLE BUCKLE (2 REQUIRED)

SKIVE TO A FEATHER EDGE



# ARM GUARD

( MAKE ONE )

CUT FROM 5-6 oz. LEATHER

USE 5/8" SKATE STRAP BUCKLES ( 3 REQUIRED )

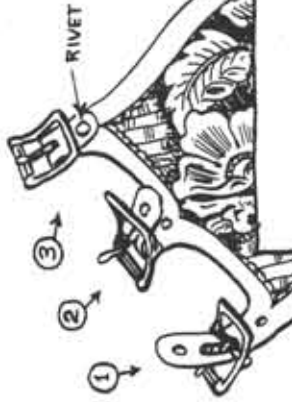

CARVE AND STAMP THE DESIGN... SKIVE ENDS... PUNCH SLOTS AND HOLES... MOISTEN FOLDS, AND RIVET BUCKLES AS SHOWN IN THE STEPS ABOVE.

SKIVE ENDS ON FLESH SIDE

RIVET HOLES

5/8" BAG PUNCH

FOLD

TEMPLATE SECTION "B"

REGISTRATION MARKS

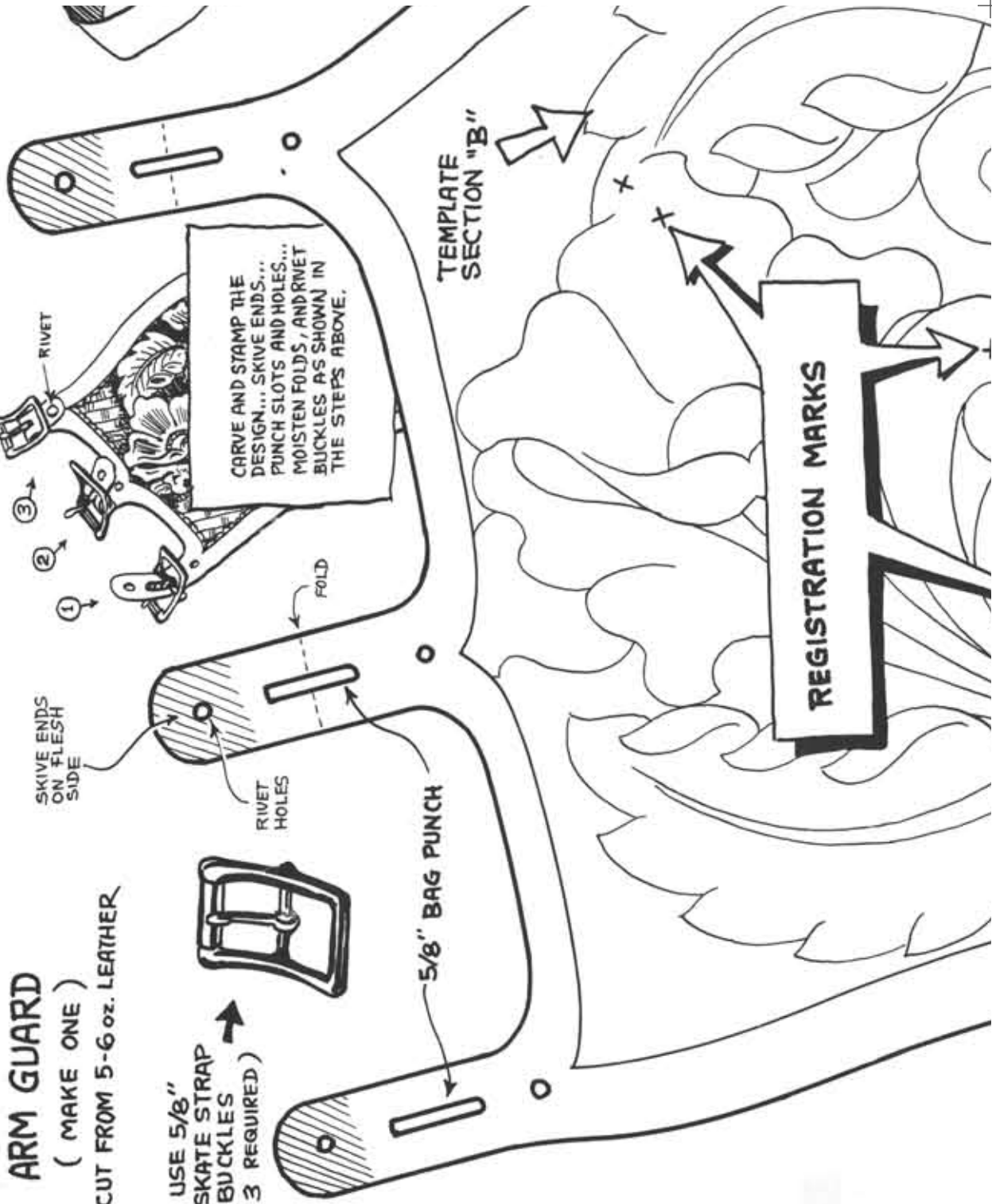



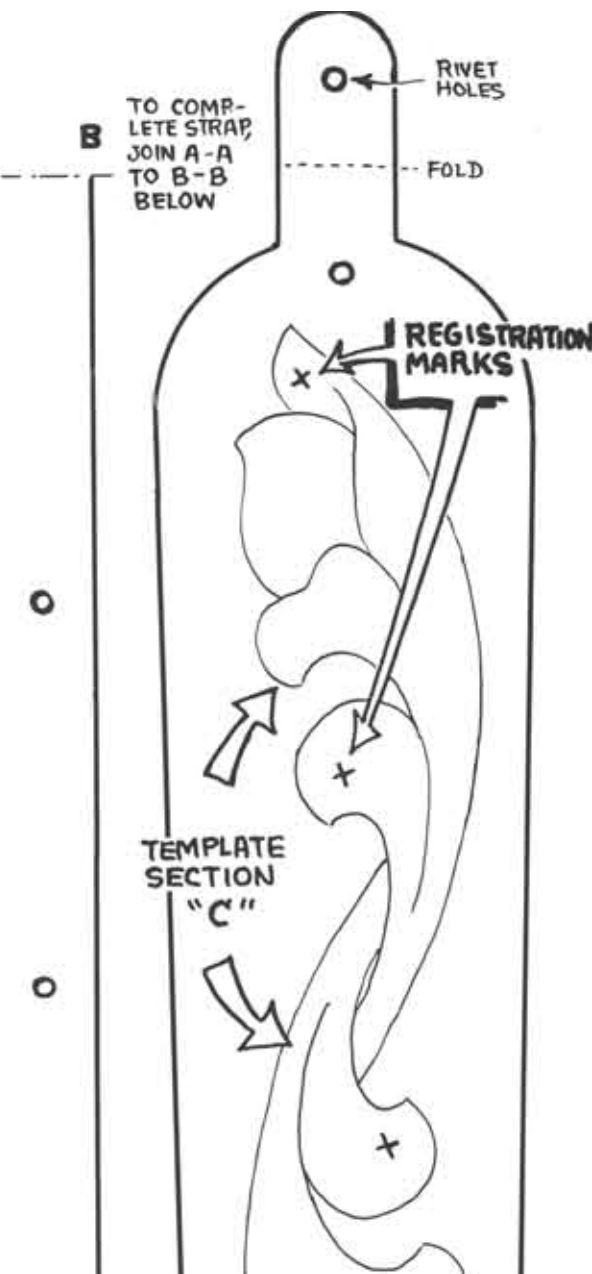
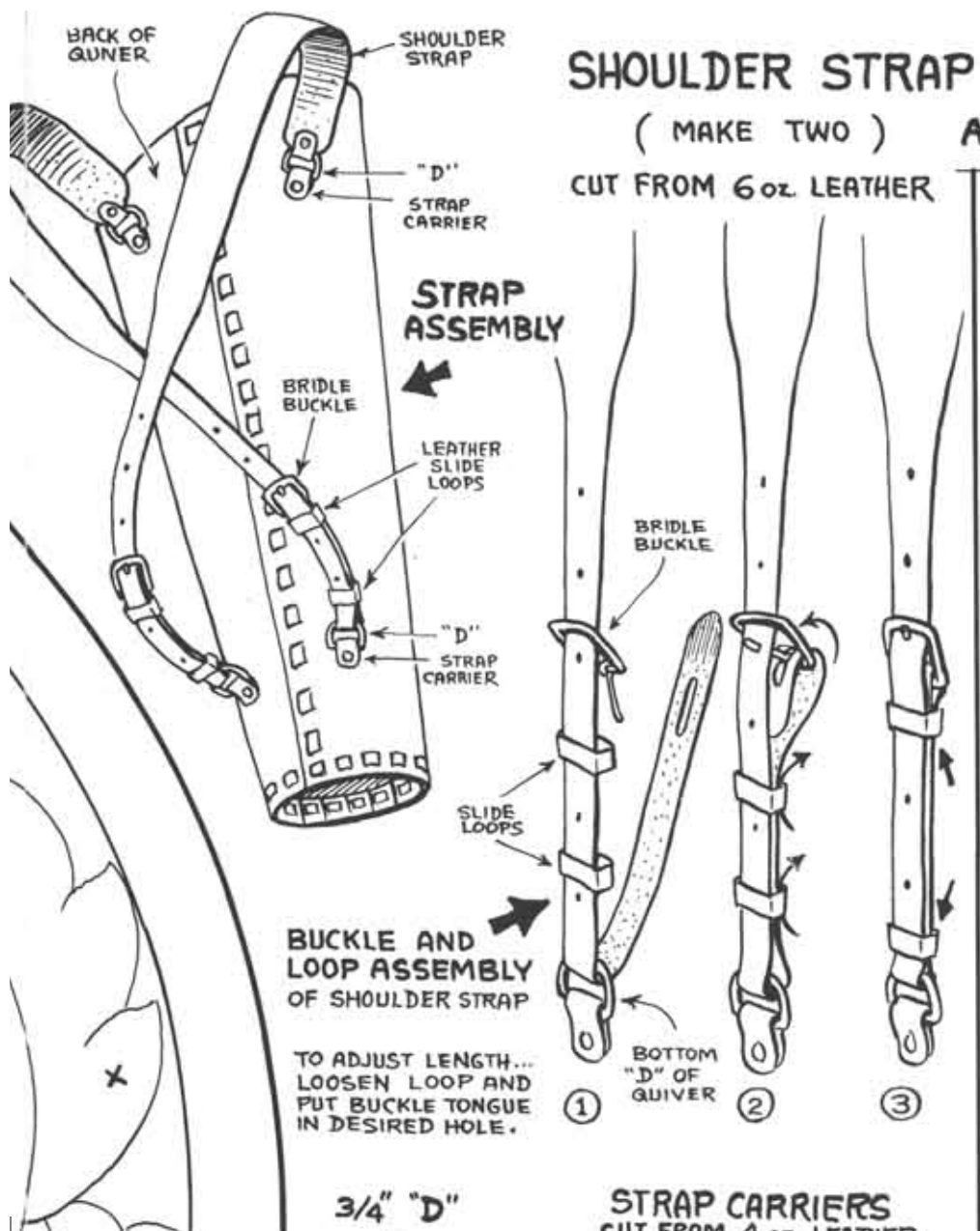

**NOTE :**  
SEE PHOTO PATTERN  
ON REVERSE SIDE  
FOR.."HOW TO USE"  
THE TEMPLATE AND  
REGISTRATION  
MARKS !

TEMPLATE  
SECTION "A"

SPACE ADJUSTMENT  
HOLES 1/4" APART

SKIVE TIPS ON  
FLESH SIDE

**BOTTOM**  
(MAKE ONE)  
CUT FROM 6 oz. LEATHER

USE  
ON T

(M  
CUT FI

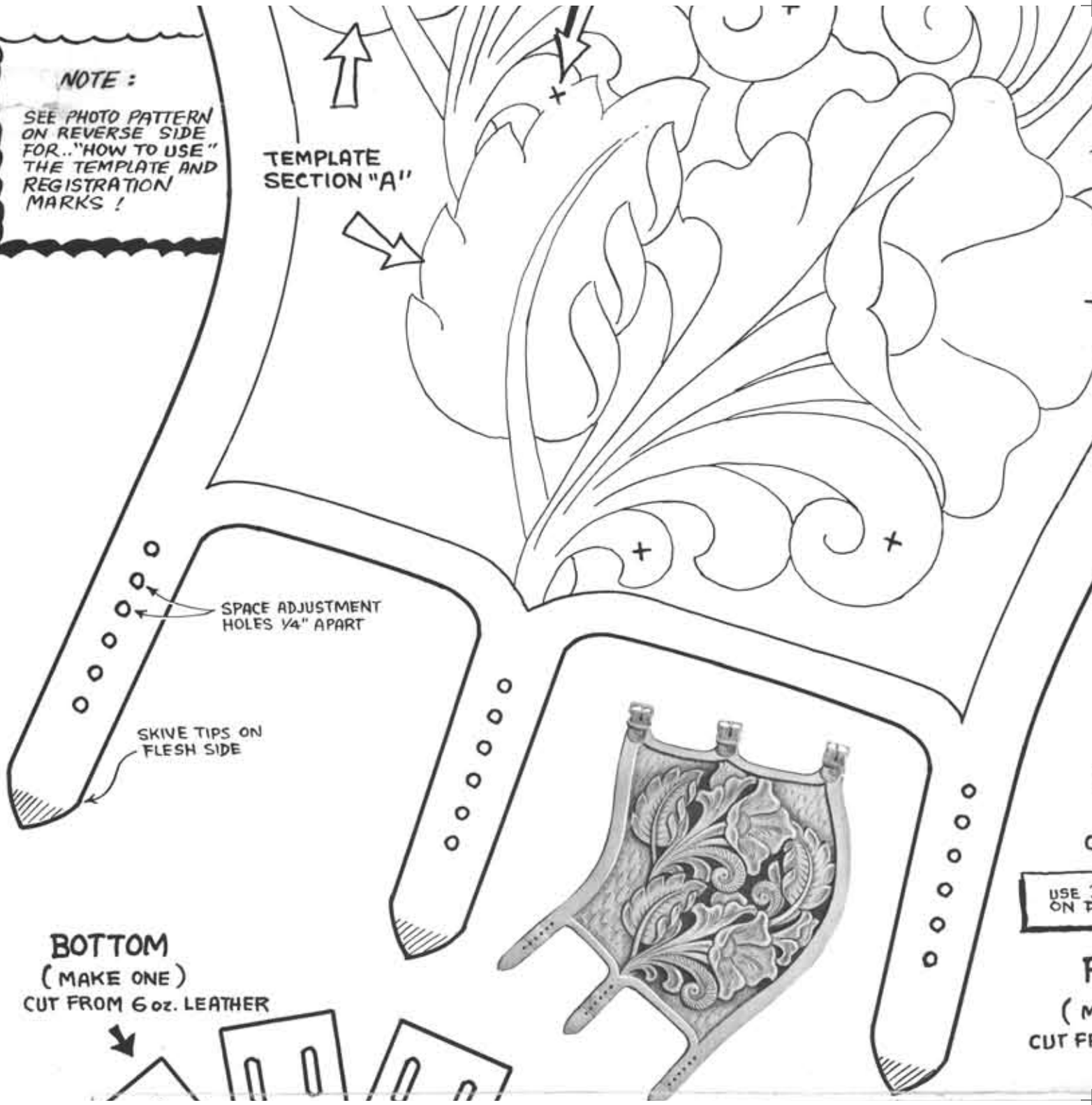

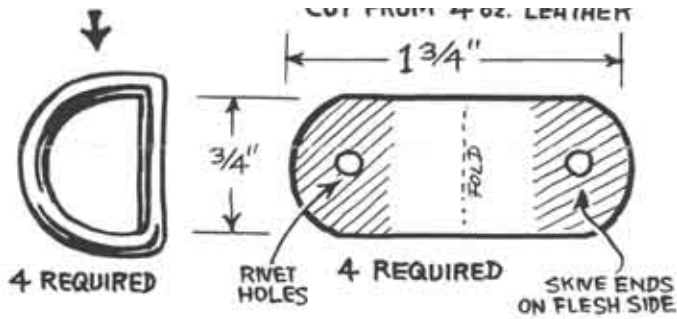

SEE ASSEMBLY INSTRUCTIONS ON ENVELOPE

**POCKET FLAP** →  
(MAKE ONE)  
CUT FROM 6 oz. LEATHER

DURABLE DOT SNAPS FOR POCKET AND FLAP

**POCKET**  
(MAKE ONE)  
FROM 6 oz. LEATHER

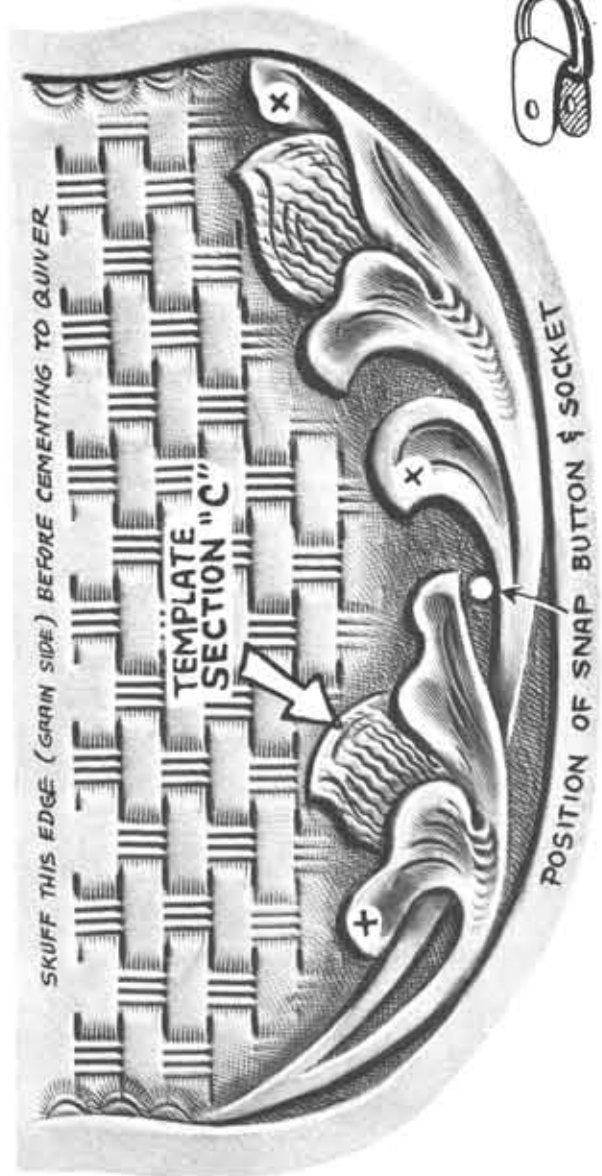

ADJUSTMENT HOLES #3 PUNCH



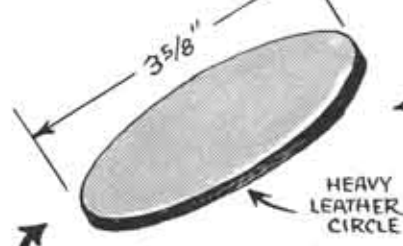
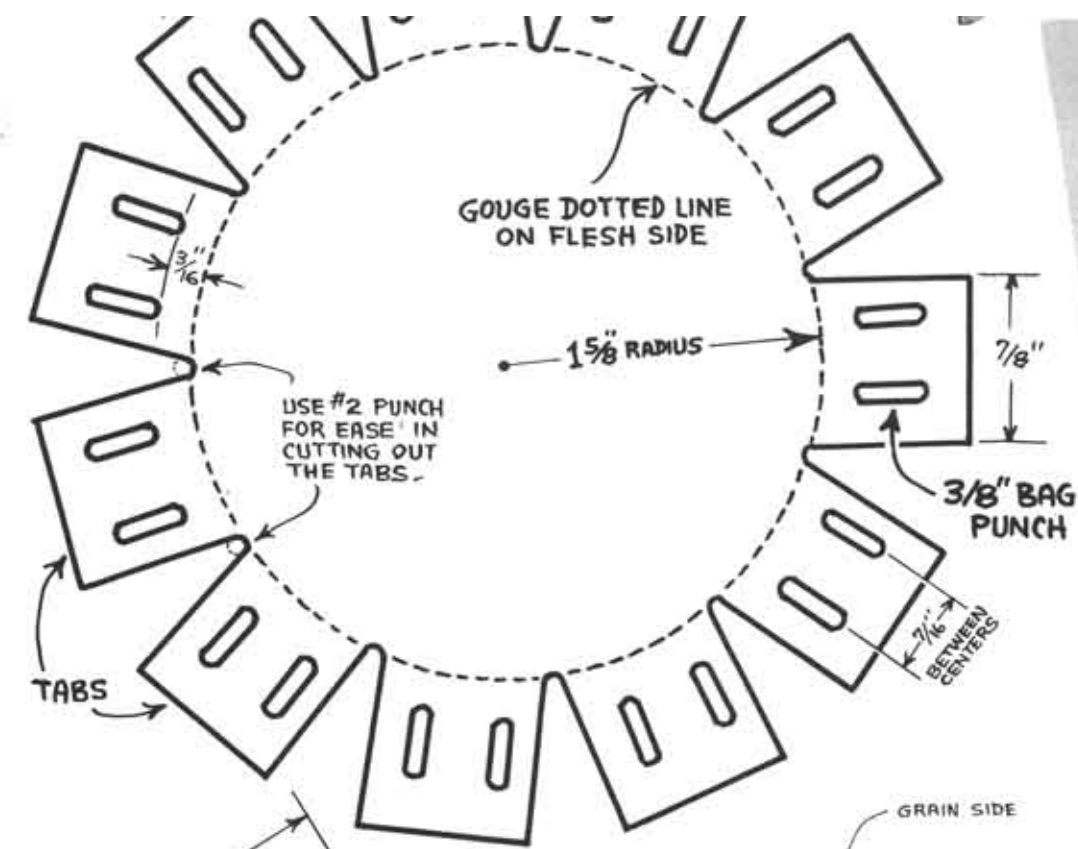

**NOTE:**  
 1/4" PLYWOOD  
 CIRCLE MAY  
 BE USED IN  
 PLACE OF  
 LEATHER.

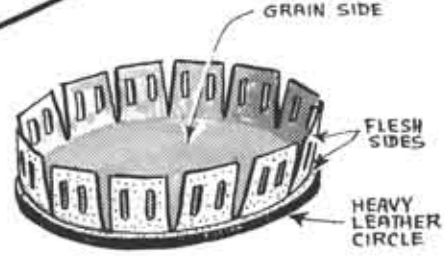

IN ADDITION TO BOTTOM,  
 CUT A PERFECT CIRCLE OF  
 10-11 oz. OR 12 oz. SKIRTING  
 LEATHER, 3 5/8" IN DIAMETER

CUT BOTTOM OUT AS SHOWN. MOISTEN  
 GOUGE AND FOLD TABS UP. CEMENT  
 FLESH SIDE OF BOTTOM TO FLESH SIDE  
 OF HEAVY LEATHER CIRCLE AS SHOWN  
 ABOVE.

**BOTTOM IS READY TO INSTALL.**  
 SEE ASSEMBLY INSTRUCTIONS ON ENVELOPE!

TEMPLATE  
 SECTION "A"  
 (LEAF ONLY)

REGISTRATION MARK  
 (SEE PHOTO PATTERN ON RE-  
 VVERSE SIDE HOW TO USE.)

899  
 MATT

TEM  
 SECT



POSITION OF SNAP EYELET & STUD

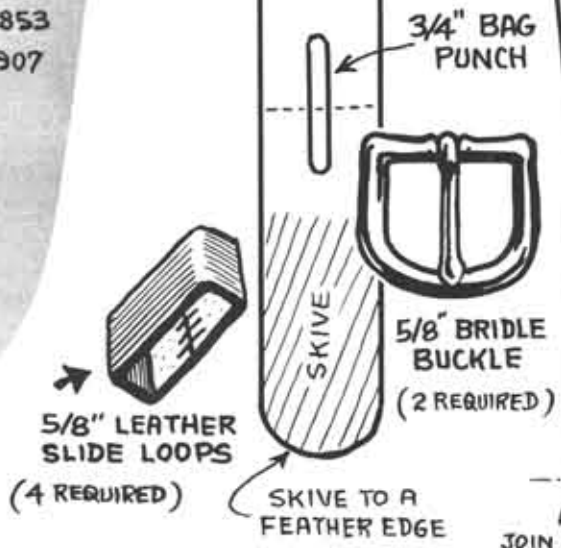
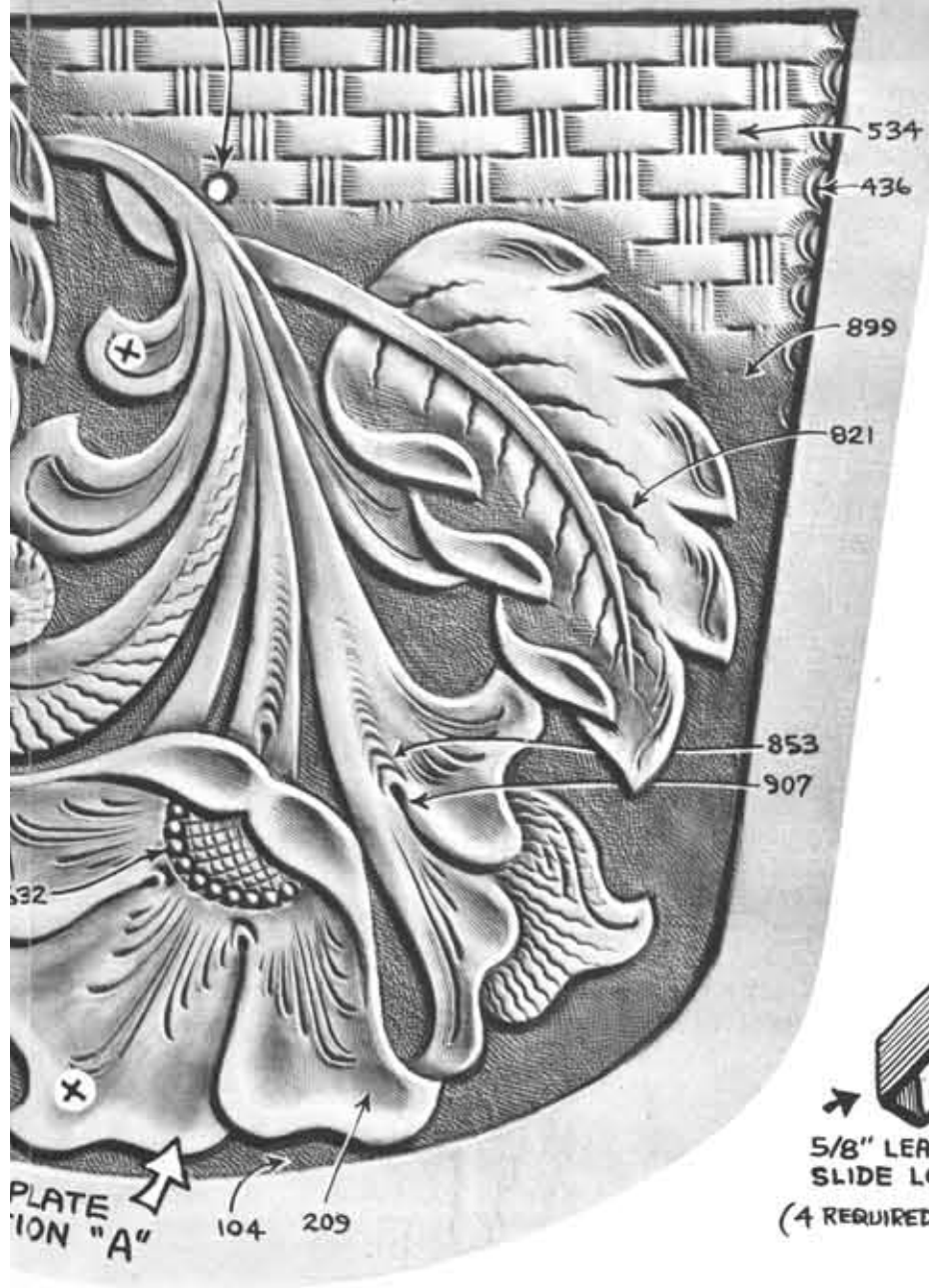

**A** **B**  
 JOIN A-A AND BB TO  
 COMPLETE PATTERN