

MESA™ 7639 | RIPPLE™ 7629

CREDENZA

INSTRUCTION MANUAL

LET'S GET STARTED.

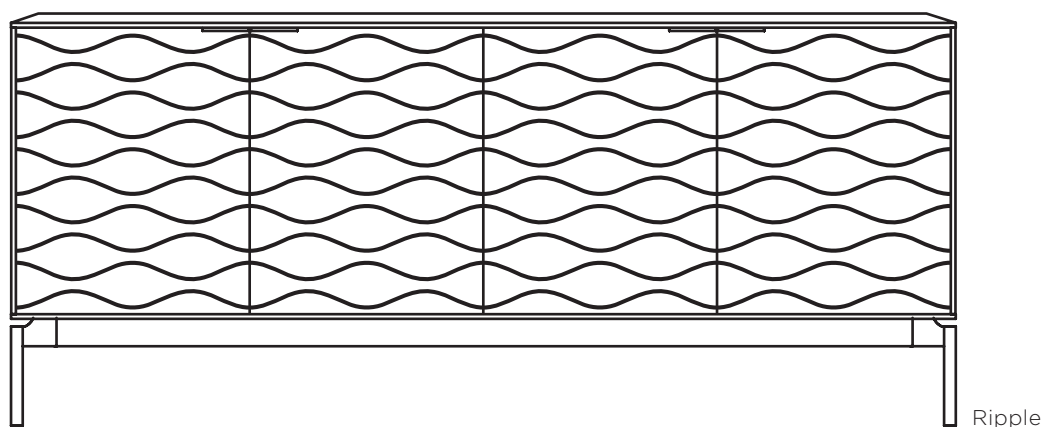
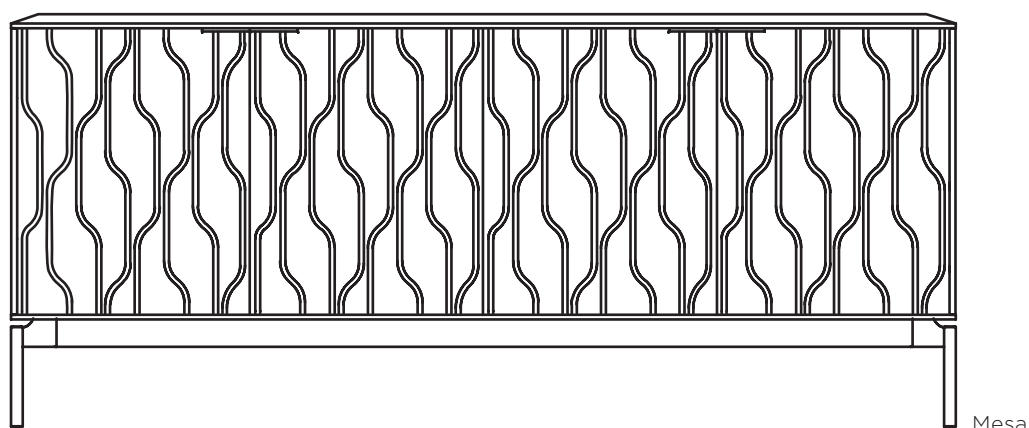

DESIGN JASON GUIDRY

BDi

BDIUSA.COM



Congratulations on the purchase of your Mesa/Ripple Credenza from BDI. Your credenza has been designed to provide a lifetime of enjoyment. This manual will provide assembly instructions and other helpful information to ensure you get the most out of your product. Please save it for future reference.

Your Mesa/Ripple Credenza has been engineered for simple assembly. Please follow these directions carefully to prevent any damage.

Should you need further assistance, contact BDI at customerservice@bdiusa.com.

ENJOY!

HARDWARE AND COMPONENTS

Unpack and identify the parts listed below. The assembly workspace should be a non-marring surface, such as carpet. For missing hardware pieces, please contact BDI Customer Service at customerservice@bdiusa.com. For all other concerns, please contact your BDI retailer.

Do not use power tools for the assembly of this product.



TOOL REQUIRED (NOT INCLUDED)
Phillips Screwdriver



Hex Wrench (T1) QTY: 1



Screw M6 x 16 (H1) QTY: 8

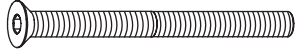

Screw M6 x 70 (H2) QTY: 6



Wood Screw (H3) QTY: 8



HARDWARE REQUIRED (NOT INCLUDED)
Drywall Anchor



HARDWARE REQUIRED (NOT INCLUDED)
Drywall Screw

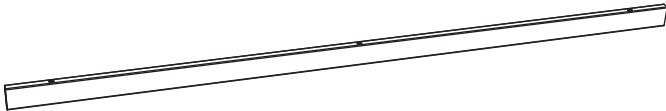

Spanner Tube (C1) QTY: 2

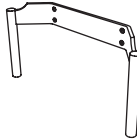

Leg (C2) QTY: 2

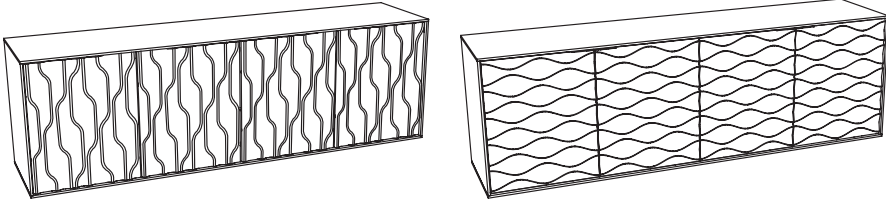

Mesa Ripple
Cabinet (C3) QTY: 1

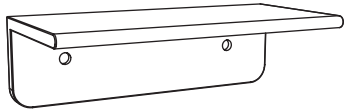

Door Pull (C4) QTY: 4

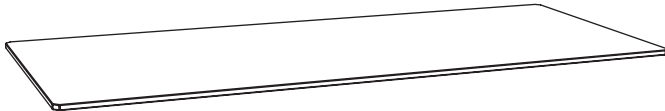

Shelf (C5) QTY: 2

*Pre-installed on the unit





Wall Anchor Strap* (C6) QTY: 1

STEP 1. ASSEMBLE BASE

ASSEMBLY

To assemble the Base, lay the **Spanners (C1)** on a soft, non-marring surface, like carpet. Attach the **Legs (C2)** to the **Spanners (C1)** using **8 Screws (H1)** and tighten with **Hex Wrench (T1)**.

	HEX WRENCH – T1	QTY 1
	SCREW – H1	QTY 8

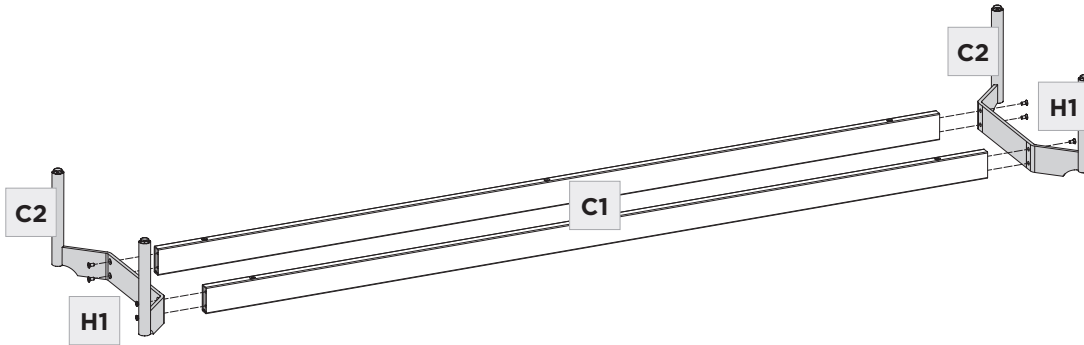

STEP 2. ATTACH BASE TO CABINET

ASSEMBLY

Lay the **Cabinet (C3)** on a soft, non-marring surface, like carpet. Attach the **Base** to the **Cabinet (C3)** using **6 Screws (H2)** and tighten with **Hex Wrench (T1)**.

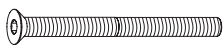
	HEX WRENCH – T1	QTY 1
	SCREW – H3	QTY 6

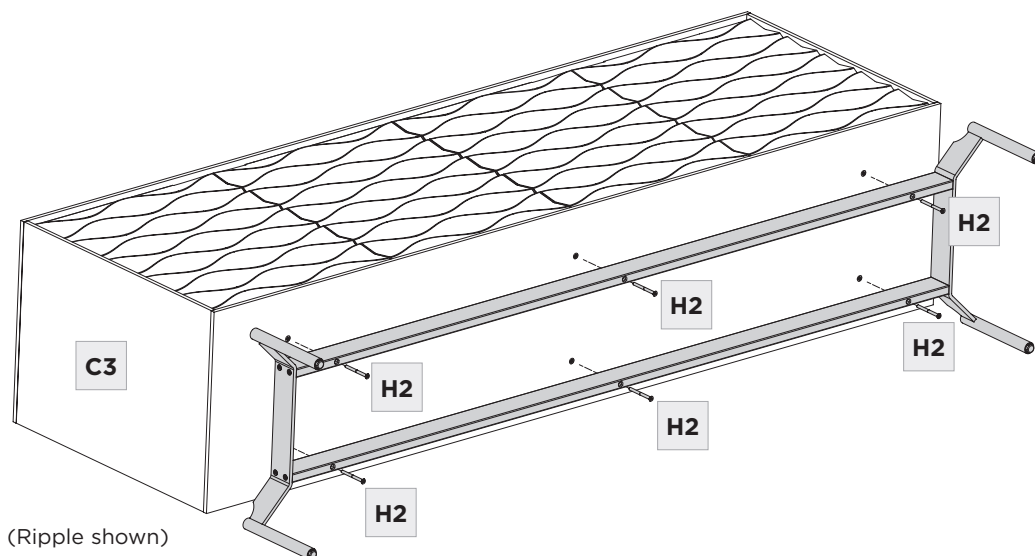

ASSEMBLY

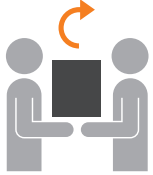

STEP 3. INSTALL DOOR PULLS

With the help of another person, carefully turn the Cabinet onto its Base. Open the doors and connect the **4 Door Pulls (C4)** with **8 Wood Screws (H3)**. Tighten with **Phillips Head Screwdriver (not included)**.

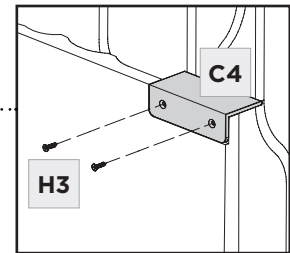
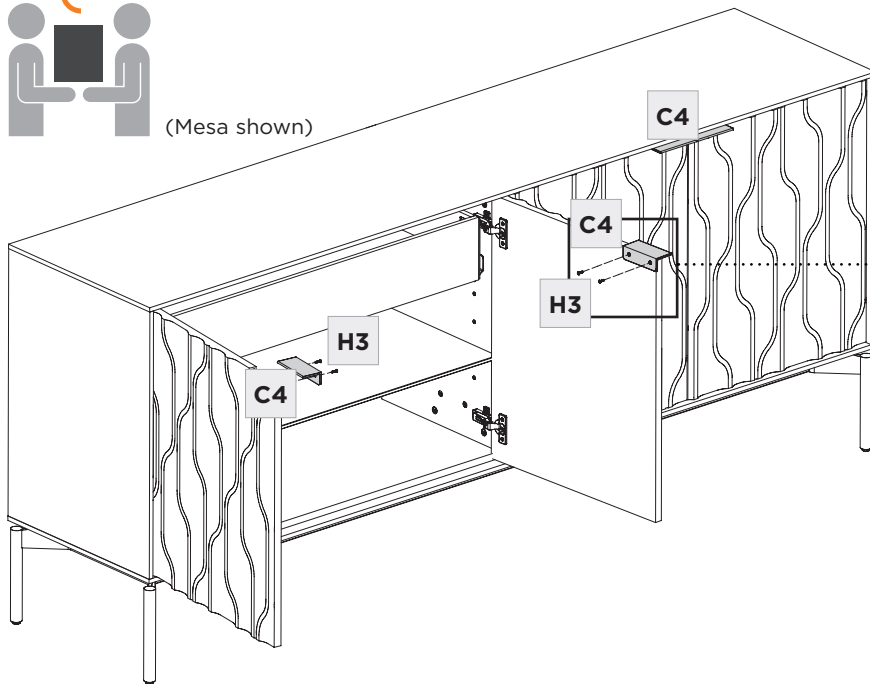

(Mesa shown)



	NOT INCLUDED PHILLIPS SCREWDRIVER	QTY 1
	SCREW – H3	QTY 8

ASSEMBLY

STEP 4. REPOSITION / INSTALL SHELVES

To adjust the shelf positions remove the **Shelves (C5)** by lifting and tilting them, then pulling them out of the cabinet. Adjust the shelf pins as needed. Replace the **Shelves (C5)** by tilting them and placing them on the shelf pins.

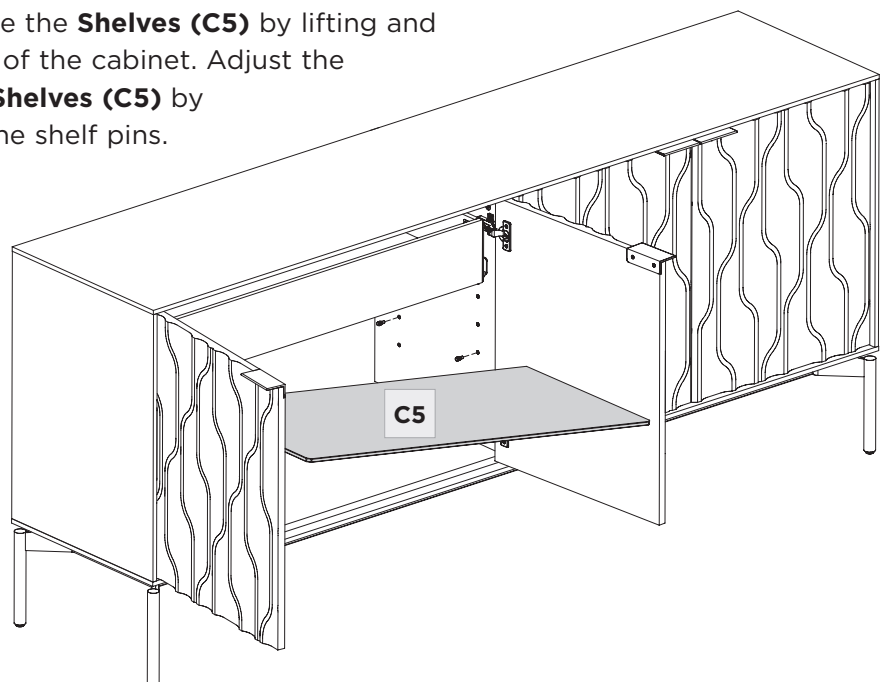

STEP 5. REMOVE & RE-INSTALL DRAWERS (OPTIONAL)

ASSEMBLY

Your cabinet shipped with the drawers installed in their **upper positions**.

The user can also move them to a **lower position** in the cabinet.

If you want to change the location of the drawers, remove them from their **drawer slides**. Look under the drawer and find the **plastic pin** on each drawer slide. Pull the plastic pins out, and gently lift each drawer up and towards you to remove them.

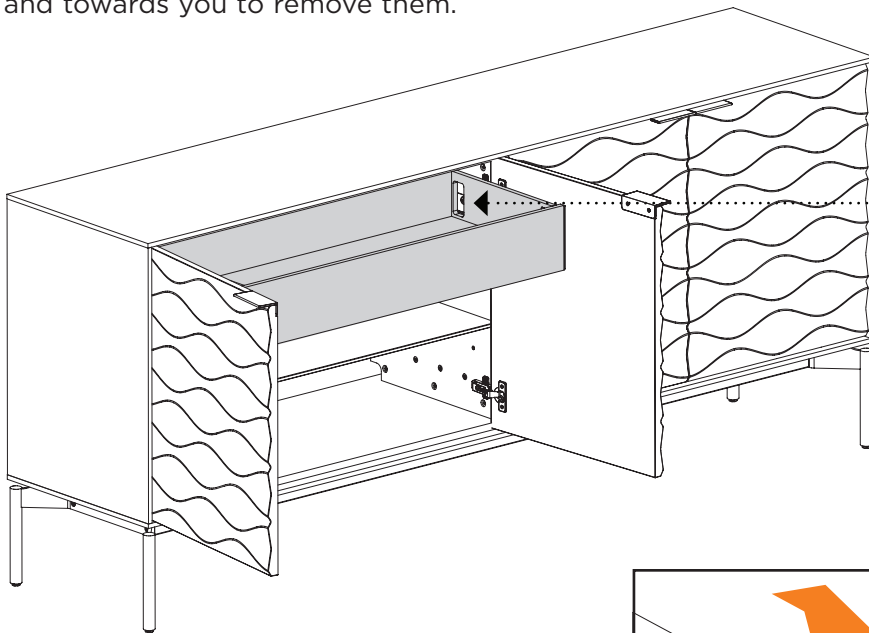
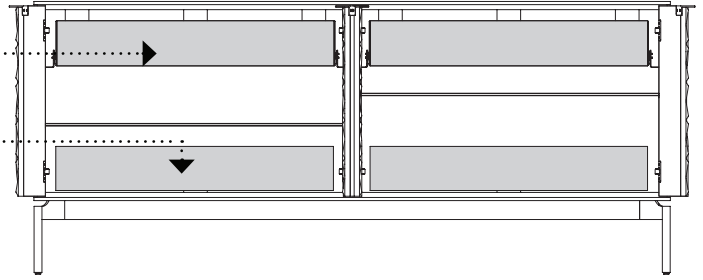

Note that the hole in the drawer side is to allow for hinge adjustment (see page 10).

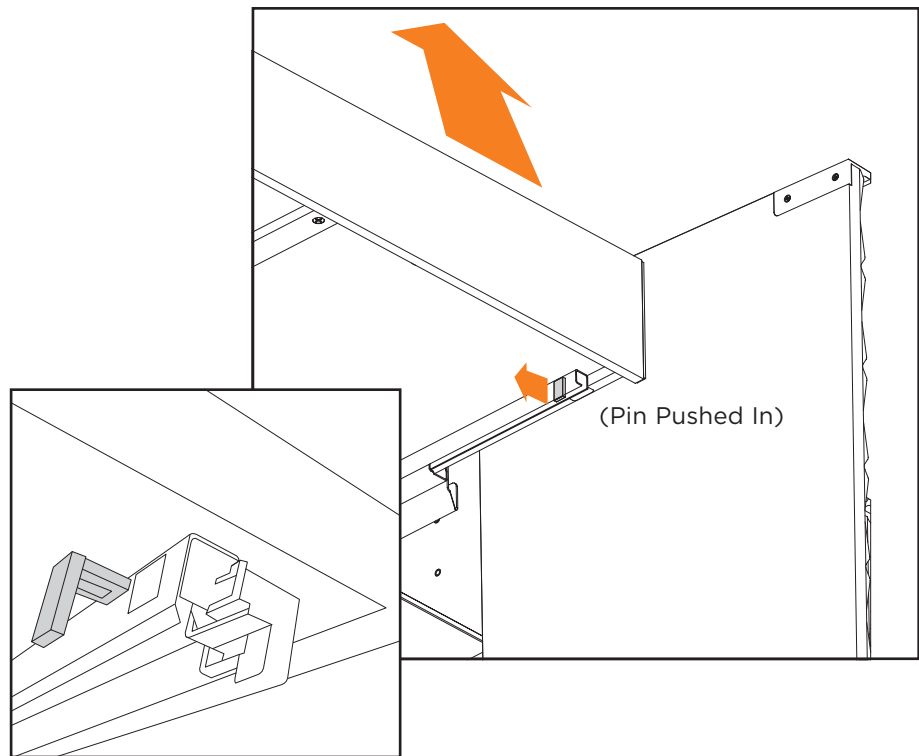

Pin Pulled Out

Remove the **screws** holding **Drawer Slide Brackets** in place using a **Hex Wrench (T1)**. **Relocate the Drawer Slide Brackets** to the desired position, and **reinsert the screws**, tightening with **the Hex Wrench (T1)**. Perform Step 5 in reverse order to reinstall the Drawer in the desired location.

	HEX WRENCH – T1	QTY 1
--	-----------------	----------

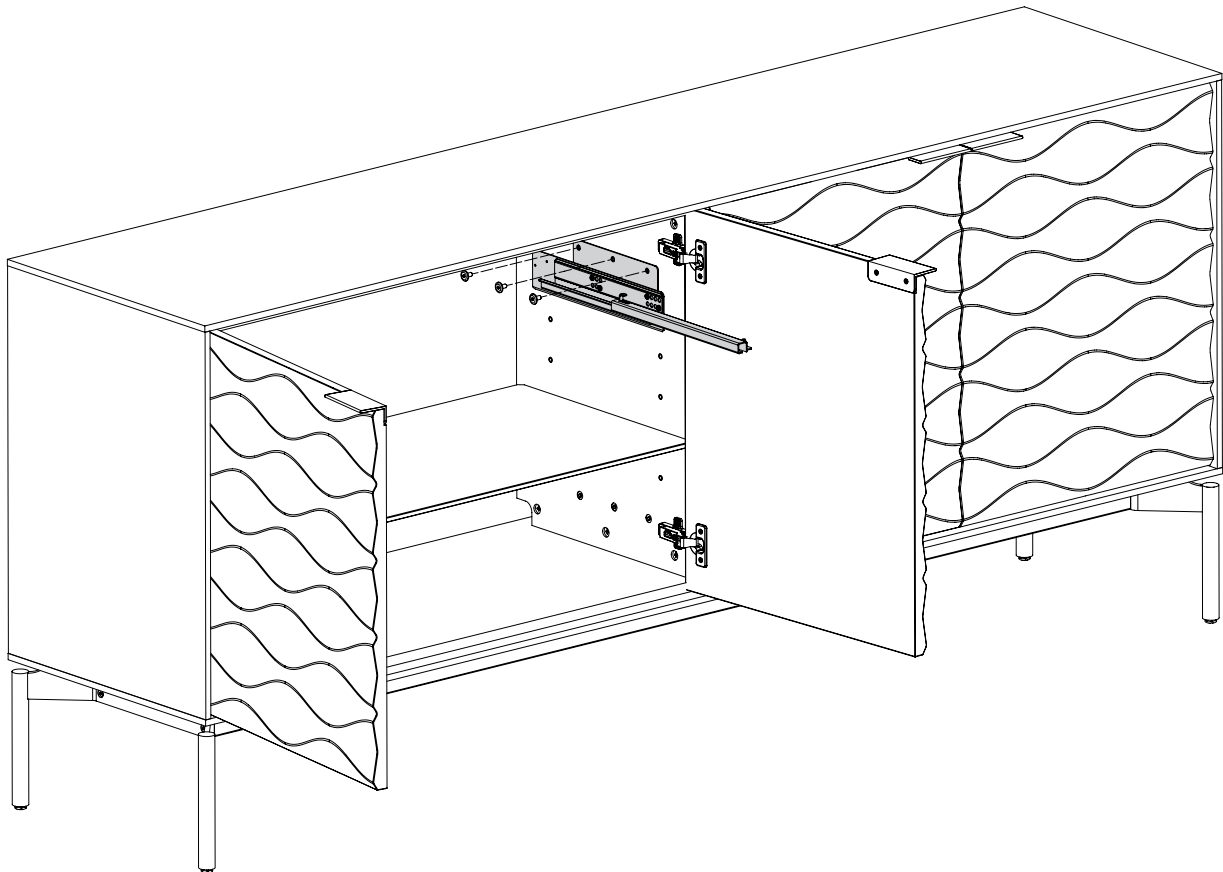



STEP 7. ANCHOR THE CABINET

ASSEMBLY

With help from another person, carefully walk the cabinet into the desired position against the wall.

It is strongly recommended that you anchor your cabinet to the wall using the provided **Anchor Strap (C6)**. Use painter's tape to mark the upper left corner of the unit, as shown.

	NOT INCLUDED WALL ANCHOR	QTY 1
	NOT INCLUDED WALL SCREW	QTY 1

With help from another person, carefully move the cabinet away from the wall. Measure and mark the wall as shown. Attach one end of the **Anchor Strap (C6)** to the wall at the marked location with an **appropriate wall anchor and screw (not included)**.

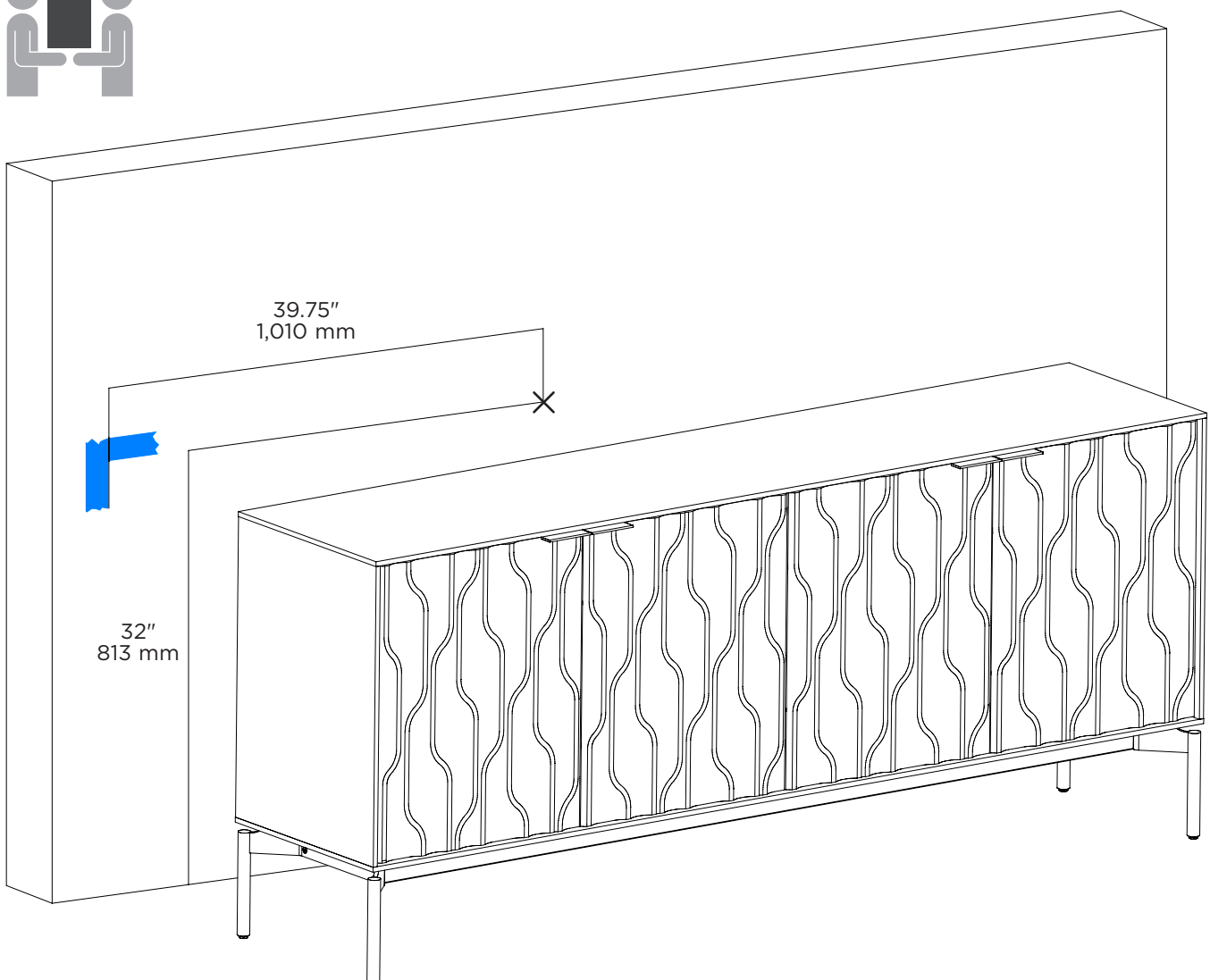
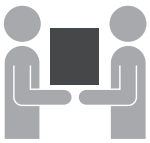

These steps are to be followed after you have unpacked and completed the simple assembly instructions for your console. Due to jostling in freight or perhaps an uneven floor, the doors on your cabinet may not appear to be in perfect alignment. Making a few minor adjustments can rectify this situation. The high-quality European hinge hardware is adjustable. Through a little adjustment, you can modify the orientation of the cabinet doors to make sure that they are sitting perfectly on your unit.

The doors on your cabinet should be evenly spaced and the doors should open and close freely without rubbing against the door frame. If the cabinet's doors appear out of alignment, this condition can be corrected with minor adjustment to the European hinges on each door. Because these hinges are adjustable, adjusting one hinge element can sometimes cause the need for adjustments to other elements. But with a few adjustments, you can modify the orientation of the cabinet doors to make sure that they hang perfectly within your cabinet.

	NOT INCLUDED PHILLIPS SCREWDRIVER	QTY 1
--	---	----------

Use a **Phillips Screwdriver (T1)** to adjust the door hinges:

- By adjusting **Screw 1**, the door will move LEFT or RIGHT within the frame. Make minor adjustments at both top and bottom hinges for best results.
- By adjusting **Screw 2**, the door will move UP or DOWN.
- By adjusting **Screw 3** the entire door will move IN or OUT, opening or closing the gap between the door frame and cabinet. (This screw rarely needs adjustment.)

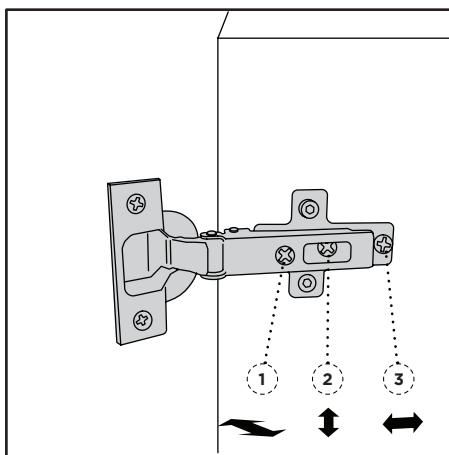

Tightening **Screw 1** on top hinge will open the seam between Door C & Door D here

Loosening **Screw 1** on this hinge will close the seam between Door C & Door D here

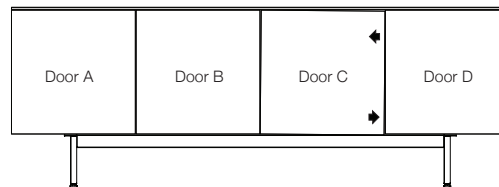
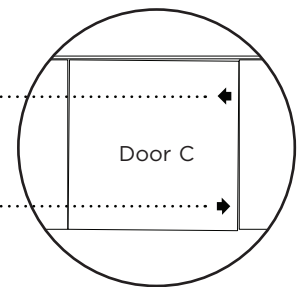

Your BDI furniture has been constructed with the finest materials, carefully manufactured, and designed to last a lifetime. Regular furniture care will prolong your enjoyment and keep it looking its best. Here are some general tips for taking care of BDI furniture. Your surfaces may vary.

GLASS

Glass surfaces are maintained using household glass cleaner and a paper towel or cloth.

SATIN-ETCHED GLASS

This uniquely smooth-to-the-touch glass surface can be regularly maintained using household glass cleaner and a paper towel or cloth.

A 'Magic Eraser' removes minor scratches or scuffs not eliminated using a paper towel or cloth. 'Magic Eraser' is a melamine foam product available at any grocery store or home improvement center. Dampen the entire glass surface and the Magic Eraser, then rub the whole surface in broad, even strokes using moderate pressure. Clean and dry the surface with a paper towel. Check for results and repeat as necessary. Any scratches or scuffing not eliminated by one of the above methods can often be addressed by 'refreshing' the glass. This process should not be required more than once per 6-12 months. See this brief video for the simple method: www.bdiusa.com/glass

WOOD

Wood surfaces should be cleaned with a slightly damp (not saturated) cloth or paper towel. Do not use glass cleaner on wood. If moisture remains, dry the surface with another cloth. If needed, a gentle, non-abrasive cleanser may be used, but wipe away all cleaner residue and dry the surface with a cloth.

BDI's wood finishes feature natural hardwood solids and veneers. Wood is a product of nature and—unlike man-made materials that can be manufactured to strict and consistent specifications—has natural imperfections that are part of its appeal and character. Every piece of wood differs from every other, even when coming from the very same tree. As such, grain, texture, and tone variation should be expected from one panel or piece of furniture to the next.

While BDI's stained wood finishes are stable in tone & appearance, all finishes are subject to some degree of discoloration with prolonged exposure to direct sunlight. Please avoid positioning your BDI cabinet in any area with ample direct sunlight. To learn more about the features of natural wood, visit www.bdiusa.com/wood

METAL, PORCELAIN, & PAINTED SURFACES

Surfaces should be cleaned with a slightly damp (not saturated) cloth or paper towel. If moisture remains, dry the surface with another cloth. If needed, a gentle, non-abrasive cleanser may be used, but be sure to wipe away all cleaner residue and dry the surface with a cloth.

WARRANTY

BDI warrants to the original purchaser that for the below-stated warranty term, BDI will repair or replace any product, part, or component covered by this warranty that fails under everyday use due to a defect in material or workmanship. BDI will repair or replace the product mentioned above, part, or component with a comparable product, part, or component. The decision to repair or replace will be at BDI's sole discretion.

BDI furniture is warranted for three (3) years from the date of purchase, as shown on your sales receipt. The warranty period starts from the date of purchase. This warranty extends only to the original purchasers who acquire new products from BDI Authorized Resellers. To be eligible for warranty coverage, any product, part, or component must have been assembled, installed, used, and maintained according to BDI's published instructions. Any modification to the original product voids the warranty.

To view BDI's complete warranty information, visit www.bdiusa.com/warranty

PRODUCT REGISTRATION

Registering your new BDI product allows us to send you important product updates, service information, and helpful hints related to your BDI products.

Register today, and you will be **entered to win free a BINK table** from BDI: www.bdiusa.com/register

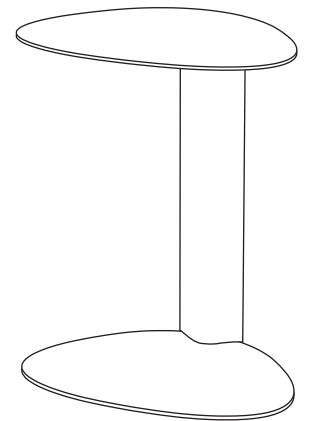

BDI

BDIUSA.COM

These distinctive product configurations are protected by US and international patents, trade dress, and/or copyright laws. Mesa, Ripple, & BDI are trademarks of Becker Designed, Inc. All rights reserved. ©2023, BDI | V.11.14.2023

Made in China.