



McIntosh Laboratory, Inc. 2 Chambers Street, Binghamton, New York 13903-2699 Phone: 607-723-3512 www.mcintoshlabs.com

MA2375

TUBE INTEGRATED AMPLIFIER
OWNER'S MANUAL



Table of Contents

Front Foam Removal	3
Rear Foam Removal.	4
Ventilation.	5
Dimensions	6
Connectors and Cables	7
Connection Diagram	8
Remote Control Operation..	9
Front Panel10
Rear Panel.11
Basic Operation12-13
Trim Function Adjustment.	12
Turntable Setup14-15
Setup Menus.16
Setup Menu Navigation..16
System Setup Submenu16
Input Setup Submenu16
Output Setup Submenu17
Data Ports Setup Submenu..17
External Control Setup Submenu17
Resetting the Microprocessors17
Specifications18
Packing Instructions19
Parts List19

Thank You from All of Us at McIntosh

You have invested in a precision instrument that will provide you with many years of enjoyment. Please take a few moments to familiarize yourself with the features and instructions to get the maximum performance from your equipment. If you need further technical assistance, please contact your dealer who may be more familiar with your particular setup including other brands. You can also contact McIntosh with additional questions or in the unlikely event of needing service.

McIntosh Laboratory, Inc.

2 Chambers Street
Binghamton, New York 13903

Technical Assistance (607) 723-3512
Fax (607) 724-0549

Customer Service (607) 723-3515
Fax (607) 723-1917

Email support@mcintoshlabs.com
Website www.mcintoshlabs.com

Please Take A Moment

For future reference, you can write down your serial number and purchase information here. We can identify your purchase from this information if the occasion should arise:

Serial Number: _____

Purchase Date: _____

Dealer Name: _____

Introduction

Meet the MA2375 Vacuum Tube Integrated Amplifier—our first Vacuum Tube Integrated Amplifier in over a decade. Crafted for the purist, but refined for the modern listener. The MA2375 extends an invitation to rediscover your music, presented in a design as iconic as the sound it creates.

This all-analog masterpiece combines a Vacuum Tube Preamplifier with a Vacuum Tube Power Amplifier in a single, elegantly designed unit, delivering a level of musicality that sets a new benchmark for Integrated Amplifiers.

Safety First

Please read the additional document **INSTRUCTIONS: Safety - Lithium Batteries - Disposal**

General Information

- The main AC power going to the MA2375, and any other component(s), should only be applied when all the system components are connected together to prevent the malfunction of the system's normal operations.
- The MA2375 has been tested and certified for indoor use only.
- To protect the anodized finish of the MA2375, limit exposure to UV light, high intensity lighting, and cleaners with harsh chemicals.
- For additional information on the MA2375 and other McIntosh products, please visit the McIntosh website at www.mcintoshlabs.com.

Front Foam Removal

To prevent damage during shipping, there are foam inserts surrounding both the front and rear vacuum tubes of the MA2375. Both foam inserts must be removed from the MA2375, and all protective cages installed before connecting AC power. Failure to do so is a fire hazard and can result in damage to the MA2375, and the surrounding environment. To remove the foam inserts and install the protective cages, perform the following steps:

1. Remove Small Cages (4)

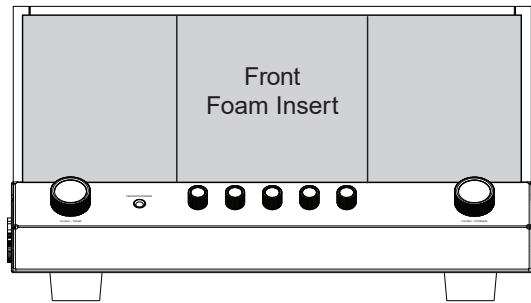
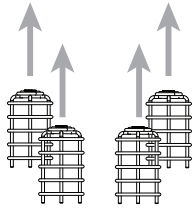

3. Install Small Cages (4)

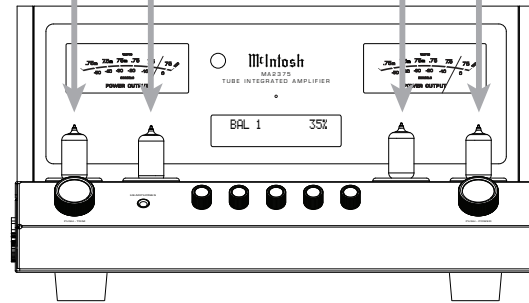

2. Remove Foam Insert

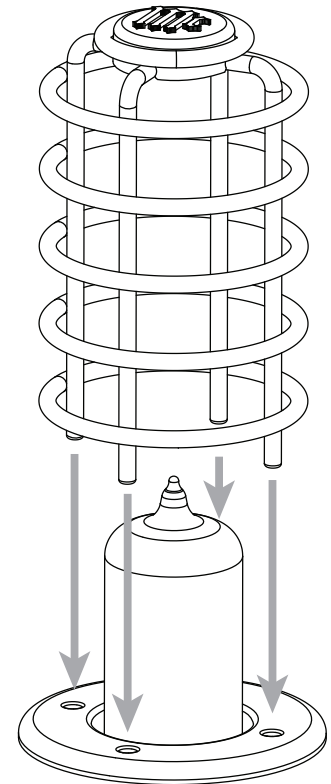
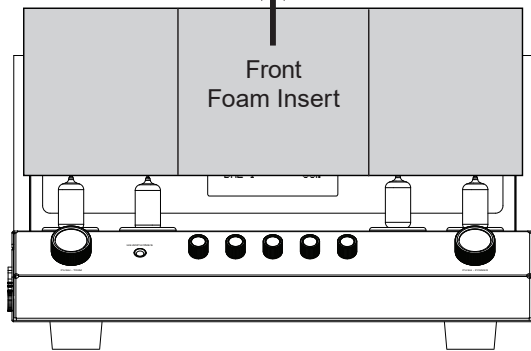

1. Remove Screws (2) & Tags (2)

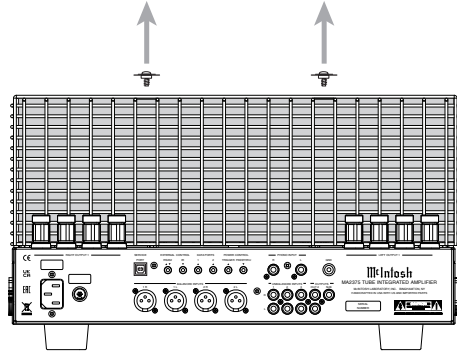

3. Remove Foam Insert

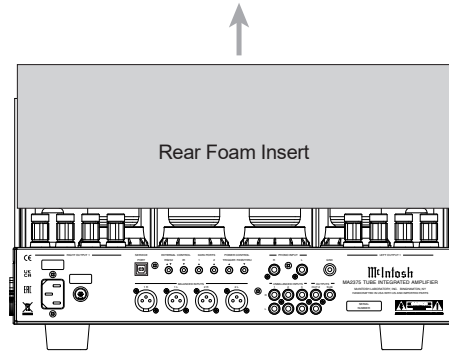

5. Replace Screws (2) & Tags (2)

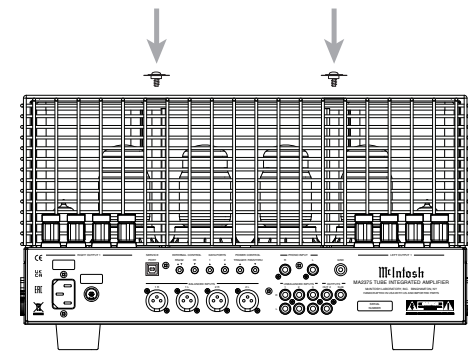

2. Remove Large Cage

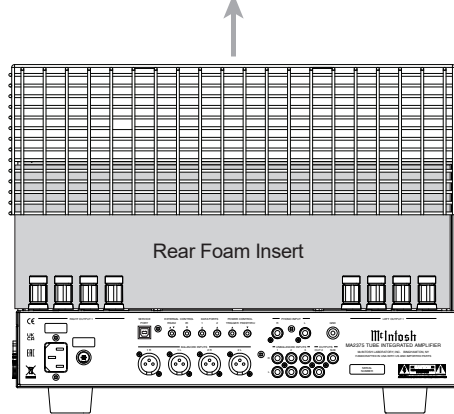

4. Replace Large Cage

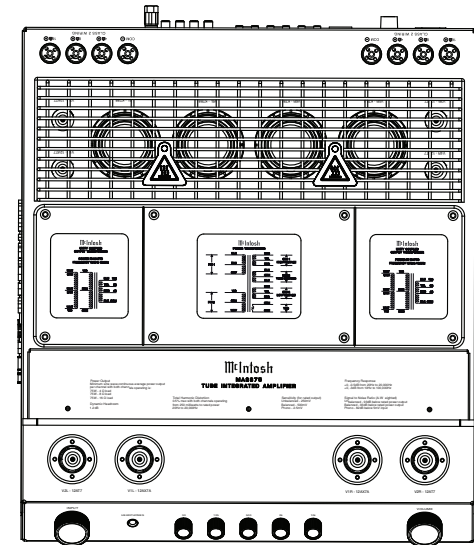
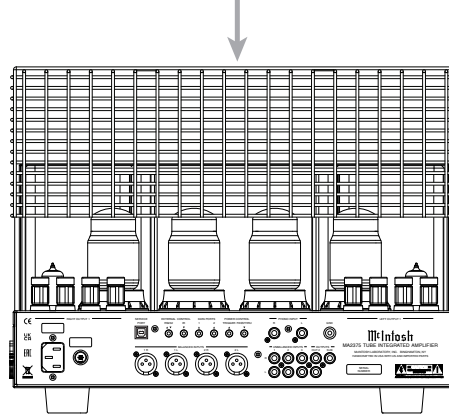

The MA2375 should be installed upright on a solid surface. Adequate ventilation will aid in a long, trouble-free life for the MA2375.

Ensure proper airflow by allowing at least 19 in (48.3 cm) above the unit, and 6 in (15.2 cm) for the front, rear, and sides.

Do not remove the feet, they ensure adequate airflow beneath the MA2375.

There must be openings for cool air to enter (below), and warm air to escape (above) the MA2375.

Warm Air

Cool Air

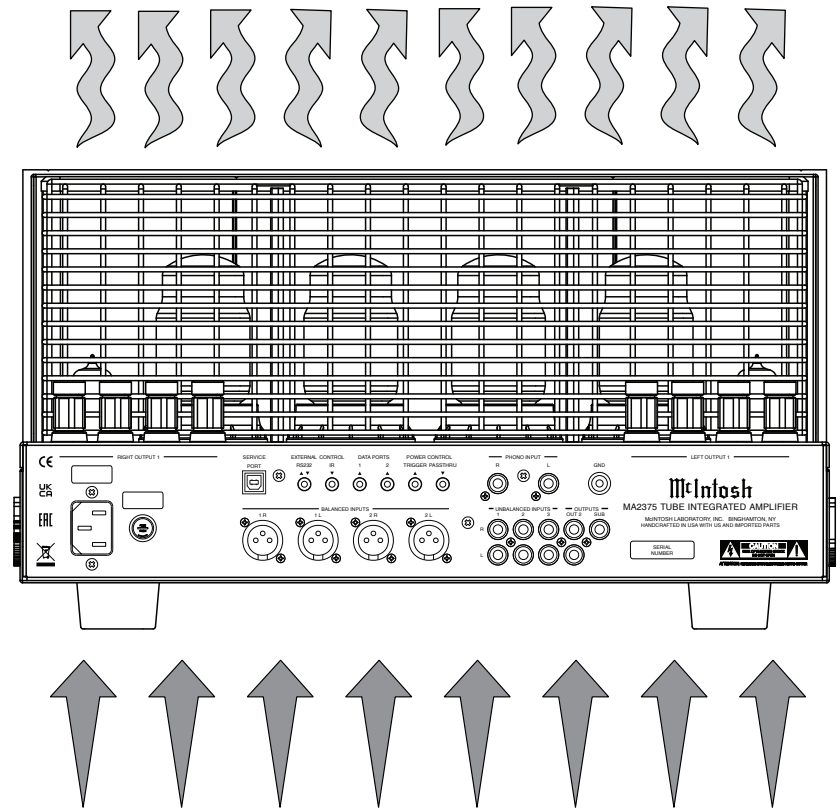
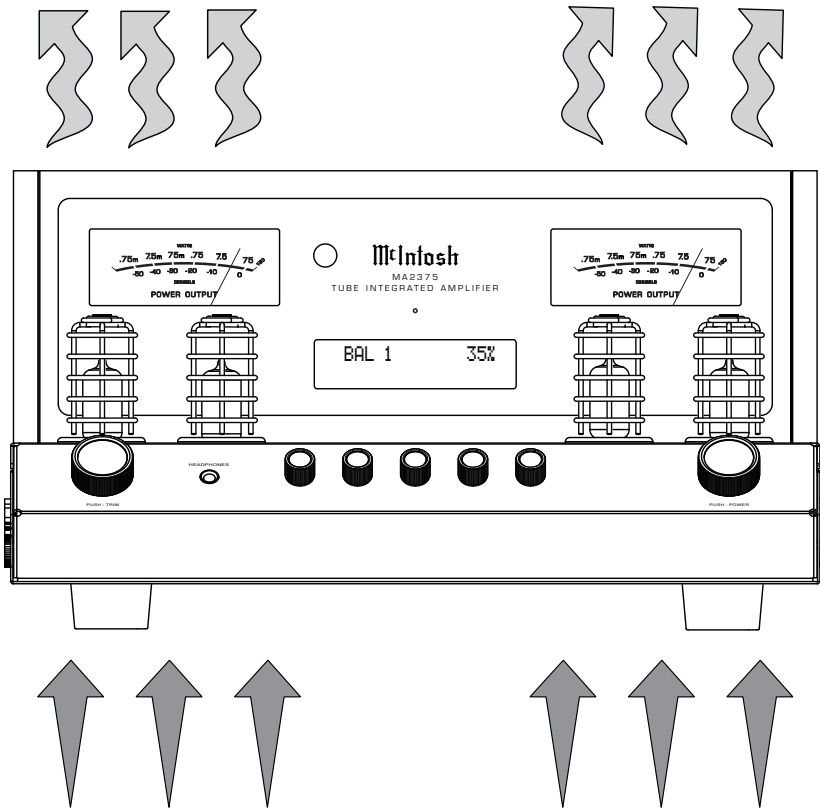

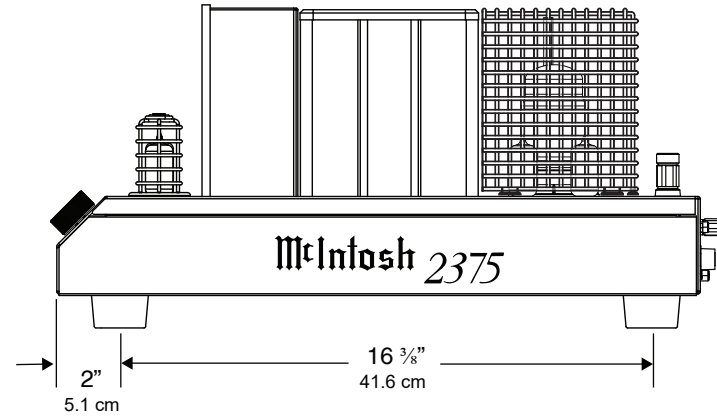
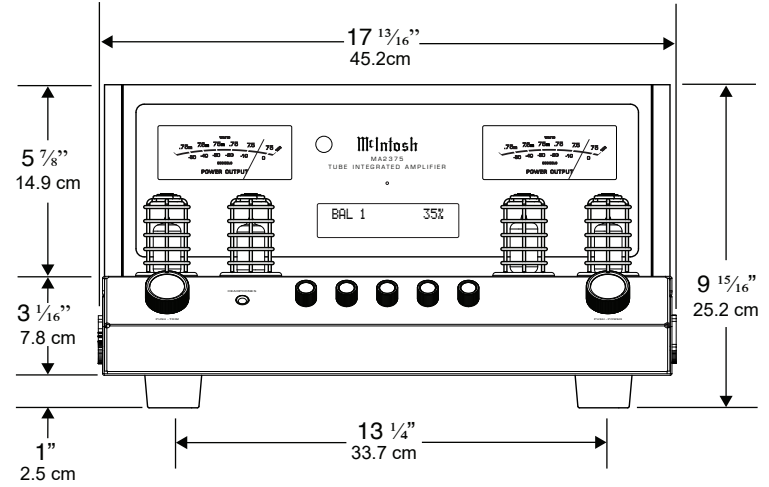
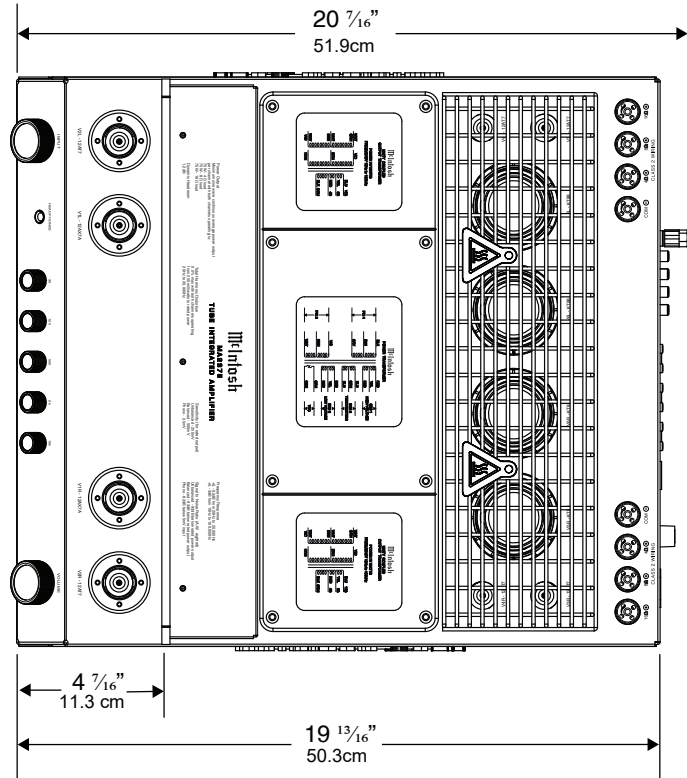

Power Control Connectors

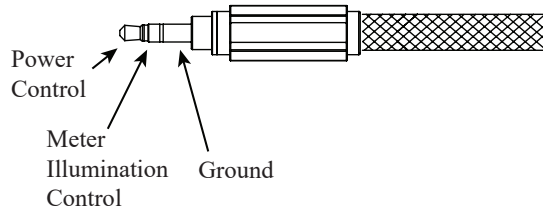

RS232-C Data Port Cable

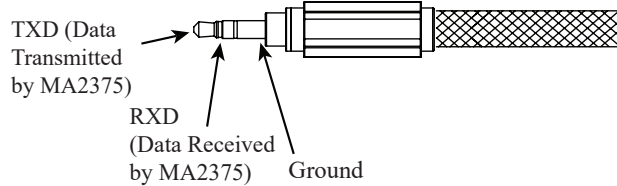

Data Port / IR Connectors

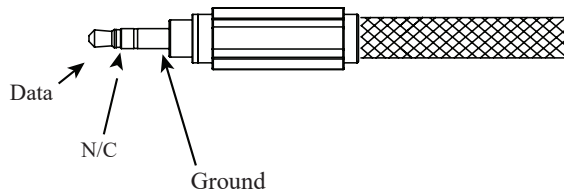

XLR Connectors

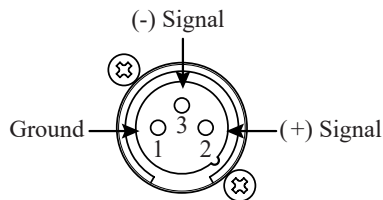

RCA Connectors

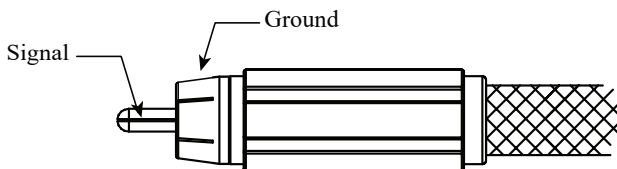

Output Terminals

Loudspeaker cables should be terminated on the ends to securely fit into the terminals according to the dimensions below.

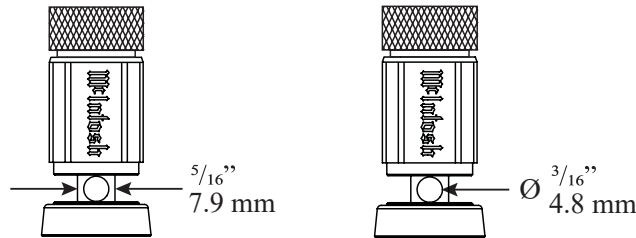

Loudspeaker Impedance

The MA2375 has four output terminals per channel, COM, +4 ohm, +8 ohm, and +16 ohm. Based on the specifications of your loudspeaker, determine the best set of terminals to use. For a speaker whose impedance falls between two choices, use the lower impedance terminal.

Loudspeaker Cables

When connecting loudspeakers to the MA2375, it is very important to use cables of adequate size. The size is specified in AWG (American Wire Gauge). The smaller the gauge number, the larger the wire size.

Loudspeaker Cable Wire Gauge Guide			
Loudspeaker Impedance	Cable Distance		
	25 feet (7.62 meters) or less	50 feet (15.24 meters) or less	100 feet (30.48 meters) or less
4 ohms	12AWG	10AWG	8AWG
8 ohms	14AWG	12AWG	10AWG
16 ohms	16AWG	14AWG	12AWG

Loudspeaker Cable Connections

When connecting loudspeaker cables to the MA2375 output terminals,

1. **Make sure AC power is disconnected.**
2. Rotate the top of the output terminal counter-clockwise until an opening appears.
3. Insert the loudspeaker cable into the output terminal. **Proper polarity must be maintained for all connections. (+/-)**

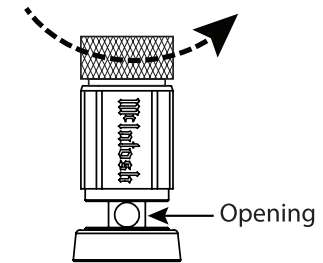

4. Rotate the top of the output terminal clockwise until it is finger-tight.
5. Place the McIntosh wrench over the top of the output terminal, and rotate the output terminal clockwise one quarter of a turn (90°). **Do not over tighten.**

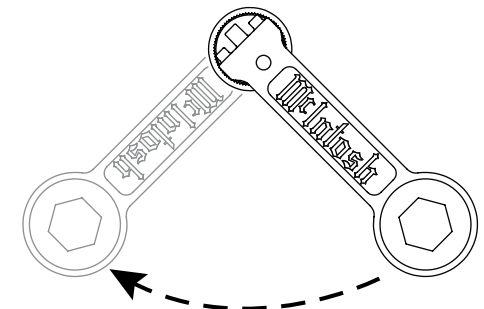

Connection Diagram

This connection diagram represents a typical 2-channel setup using the MA2375, disc player, turntable, and a pair of loudspeakers. Connect the components of the desired system in a similar manner.

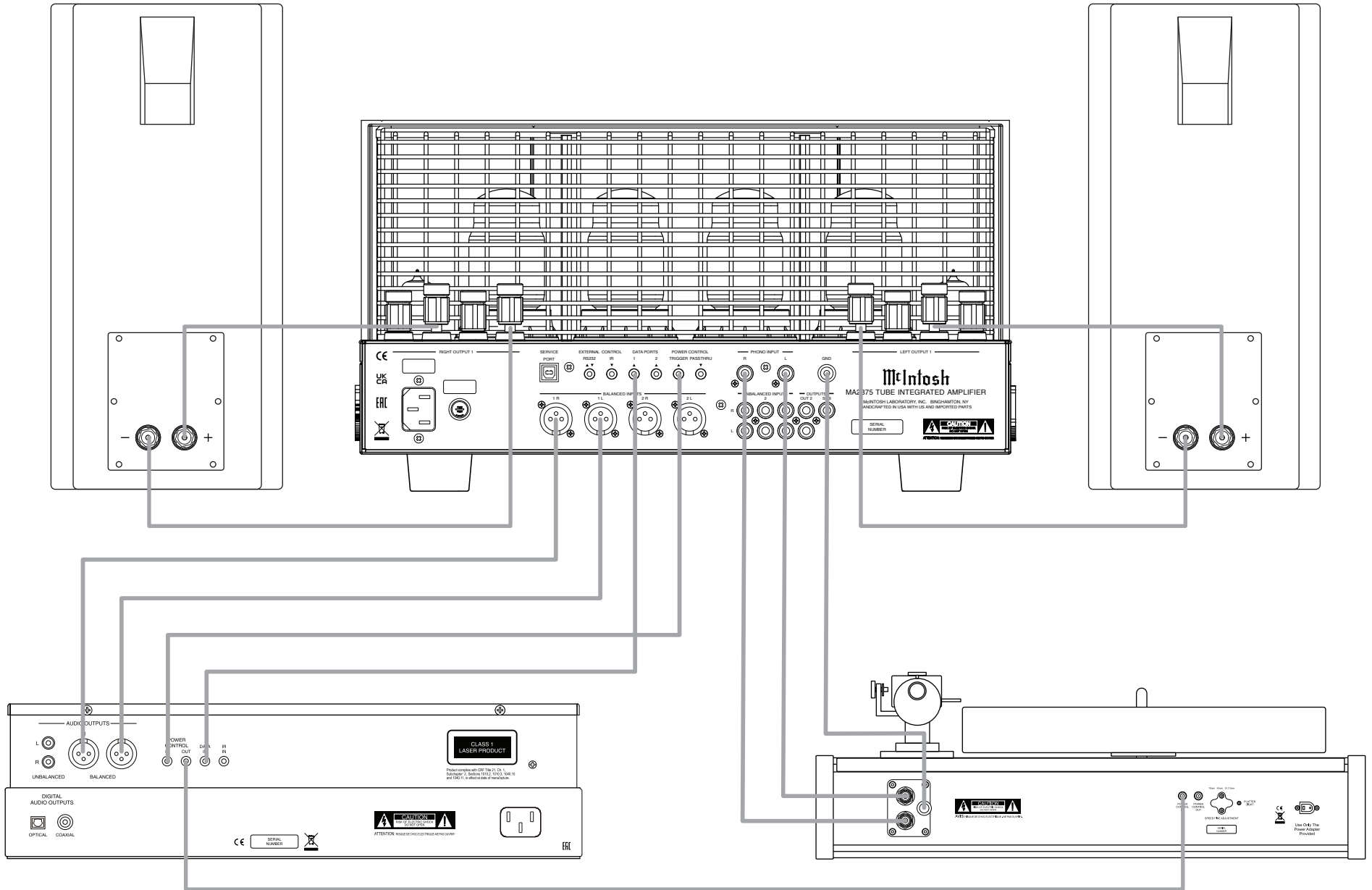

Remote Control Operation

1. **Switch Device¹** jumps through different devices for remote operation. The selected device is indicated by the LED's to the right of the button.
2. **Numbers¹** select tuner presets, manually enters disc tracks and radio stations, and performs various other operations.
3. **SETUP** accesses additional functions of the AM and FM buttons, working as a "shift" key to access OUTPUT 1 and OUTPUT 2 functions.
(Note: Cannot be used to enter the MA2375's Setup menu.)
4. **AM Tuner¹/OUTPUT 1** accesses AM Tuner, or toggles Output 1 if pressed after the SETUP button.
5. **LEVEL UP/MENU** accesses Trim functions in the Settings menu of compatible devices.
6. **TRIM/GUIDE** enters Trim menu, and opens Guide on compatible devices.
7. **INFO/LEVEL DOWN** accesses Trim functions in the Settings menu of compatible devices.
8. **Mute:** stops all audio playback.
9. **INPUT** changes and selects different inputs.
10. **Play/Pause¹** halts playback of active media, and resumes upon pressing the button again.
11. **Stop¹** cancels playback, and resets progress in the active media.
12. **Previous/Previous PRESET¹** goes back to the previously selected media, and navigates to a previous tuner preset.
13. **Fast Reverse/SEEK Down¹** navigates backward through the active media, and adjusts the Tuner downward.

14. **Fast Forward/SEEK Up¹** navigates forward through the active media, and adjusts the tuner upwards.
15. **Next/Next PRESET¹** moves forward to the next media selection, and navigates to a later tuner preset.
16. **Record¹** records actively playing media.
17. **VOL** adjusts the volume.
18. **BAND¹** changes the band on the connected tuner, and selects certain options on various McIntosh models.
19. **MODE/EXIT** exits the Trim menu, and displays information and options.
20. **SELECT¹** picks the highlighted option where applicable.
21. **FM Tuner¹/OUTPUT 2** accesses FM Tuner, or toggles Output 2 if pressed after the SETUP button.
22. **PRESET¹** selects a stored preset when pressing PRESET followed by the number (0-9) associated with the desired preset.
23. **Power Off** turns off the selected device.
24. **Power On** turns on the selected device.

Additional Discrete Commands

Additional discrete commands for external control systems are available for toggling power, and selecting audio inputs. These additional commands can be accessed using an optional McIntosh HR093 service remote control. Contact McIntosh Technical Assistance, or your dealer for more information.

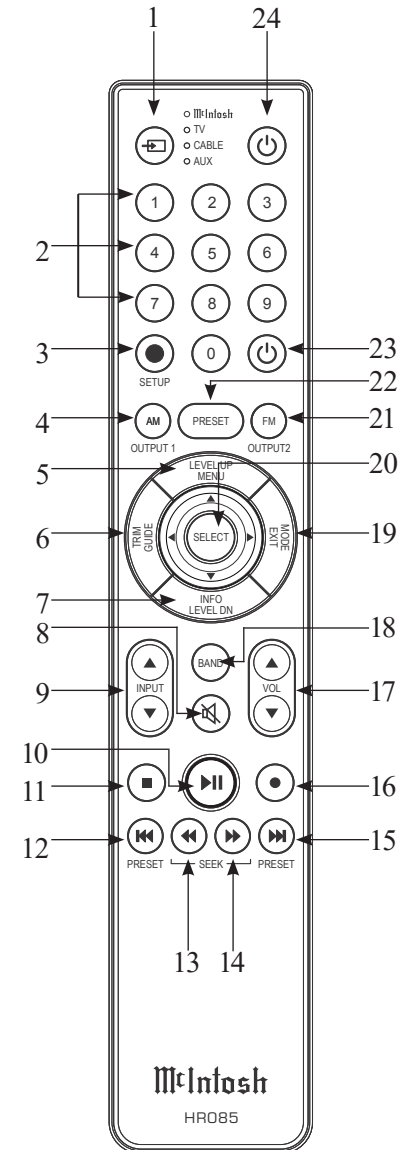

Note: The included McIntosh HR085 remote control has buttons used to control multiple devices. While operating the MA2375 with the remote, nothing will happen when pressing buttons that activate features not present on the MA2375.

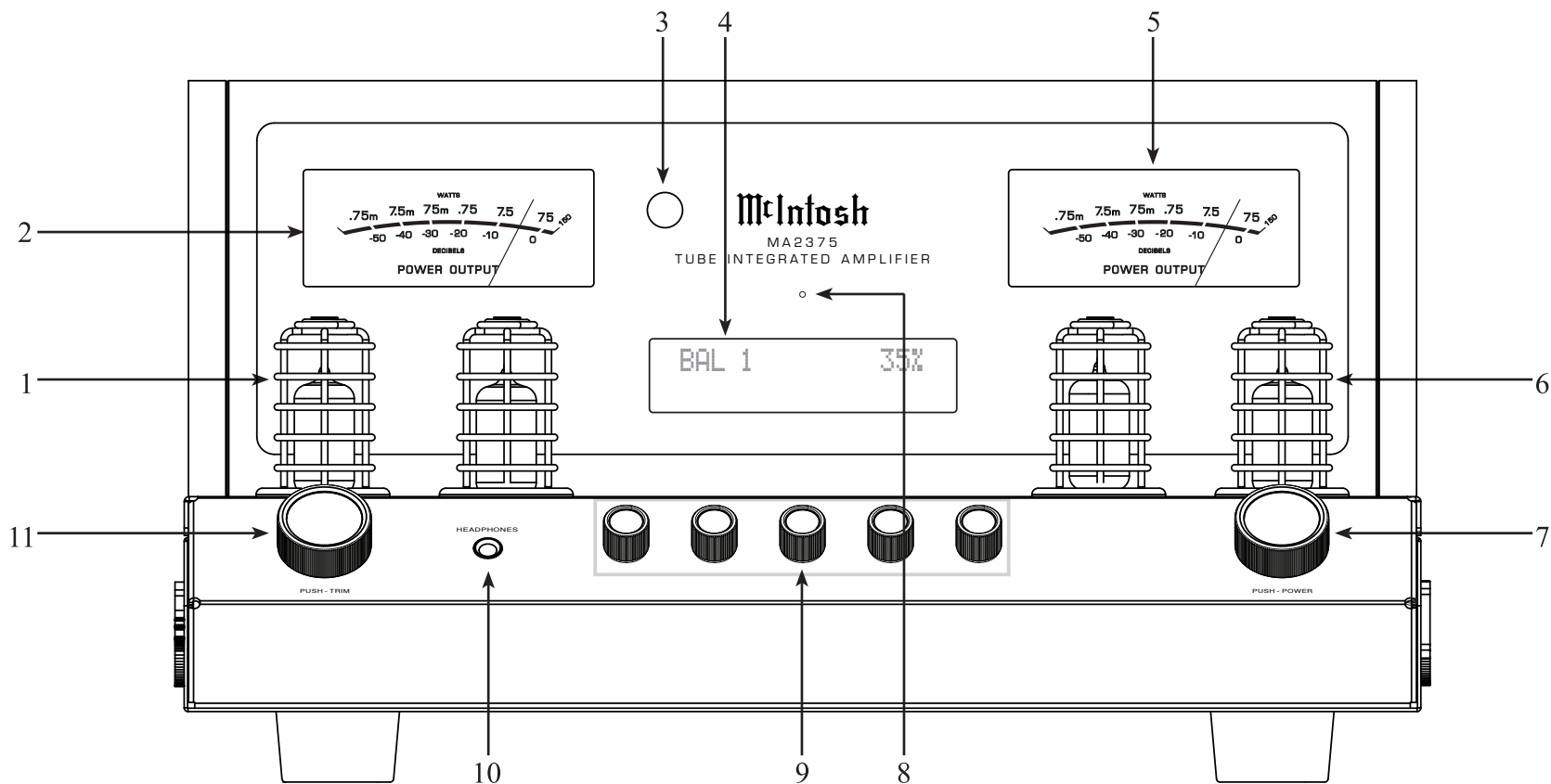

Front Panel

1. **Left Preamplifier Vacuum Tubes**
Orange - Warmup mode/Left Power Guard
Green (or off) - Normal operation
2. **Left POWER OUTPUT Meter** indicates the left channel output level in WATTS and DECIBELS.
3. **IR Sensor** receives commands from a remote control.
4. **Information Display** indicates input selection, volume setting, and the Trim, and Setup menus.
5. **Right POWER OUTPUT Meter** indicates the right channel output level in WATTS and DECIBELS.
6. **Right Preamplifier Vacuum Tubes**
Orange - Warmup mode/Right Power Guard
Green (or off) - Normal operation
7. **VOLUME Knob** allows adjustment of the listening level for both channels and is used to change various Trim and Setup functions. Push to turn the MA2375 on/off.
8. **Standby LED** indicates AC power is present, allowing the MA2375 to be turned on. If flashing, the sentry monitor protection circuits have activated.
9. **Equalizer Knobs** increase or decrease the volume levels at the center frequencies of 30 Hz, 125 Hz, 500 Hz, 2k Hz, and 10k Hz.
10. **HEADPHONE** connection for private listening.
11. **INPUT Knob** is used to select a source for listening. Push to enter the TRIM menu. Push and hold to enter the SETUP menu.

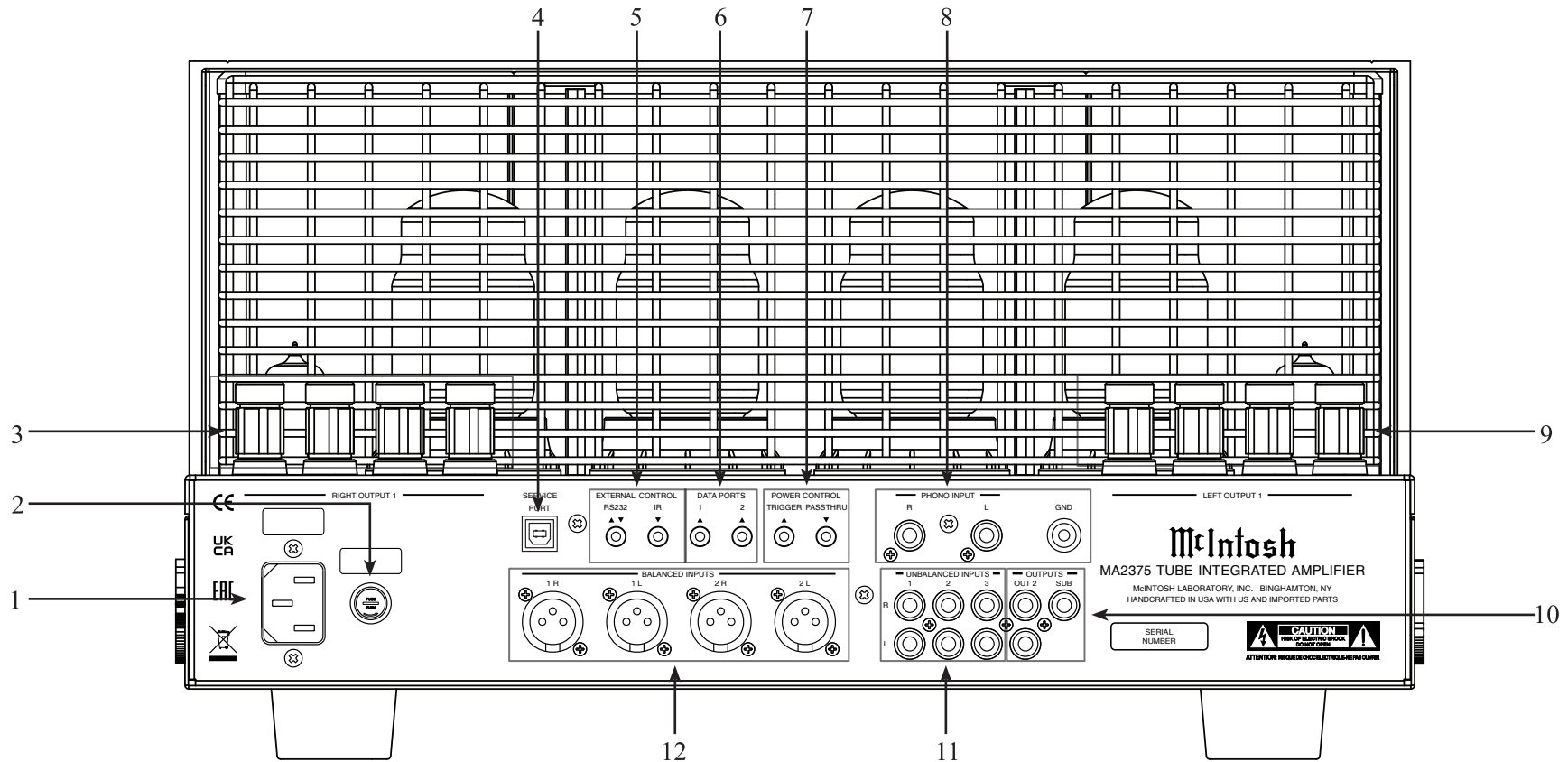

Rear Panel

1. **AC Input** connects the MA2375 power cord to a live AC outlet. Refer to the rear panel for voltage and current requirements.
2. **Main Fuse Holder**, refer to the rear panel to determine the correct fuse size and rating.
3. **RIGHT OUTPUT 1** connections for a 4, 8, or 16 ohm loudspeaker.
4. **SERVICE PORT** is used to update the MA2375 firmware.
5. **EXTERNAL CONTROL** connections allow for control of the MA2375 from either a RS232 third-party control system, or a remote IR Sensor.
6. **DATA PORTS** retransmit remote control signals to source components.
7. **POWER CONTROL** connections allow for turn on/off control of other McIntosh components. **TRIGGER** sends a turn on/off signal to another component. **PASSTHRU** receives a turn on/off signal from a home theater processor.
8. **PHONO INPUT** accepts phono signals and a GND connection from a turntable.
9. **LEFT OUTPUT 1** connections for a 4, 8, or 16 ohm loudspeaker.
10. **Preamplifier OUTPUTS** can be used to drive additional amplifiers. **OUT 2** provides a full range stereo output, and **SUB** provides a full range mono output.
11. **UNBALANCED INPUTS** 1, 2, and 3 accept line level unbalanced signals.
12. **BALANCED INPUTS** 1 and 2 accept line-level balanced signals.

Basic Operation

Power On and Off

The red LED above the information display indicates the MA2375 is in Standby mode. To switch on the MA2375, press the VOLUME knob on the front panel, or the green \cup button on the remote control. Upon turning on the unit, there will be a brief “Warmup” period before the unit is ready to use. To switch off the MA2375, press the VOLUME knob on the front panel, or the red \cup button on the remote control.

Input Selection

Rotate the INPUT knob on the front panel, or use the INPUT \uparrow \downarrow buttons on the remote control to select the desired input.

```
BAL 1 15%
```

Volume Control

Rotate the front panel VOLUME knob, or use the VOL \uparrow \downarrow buttons on the remote control to set the desired listening level.

Trim Function Adjustment

The MA2375 has a variety of different trim settings that customize various audio, and lighting options. *Selection and adjustment of all trim functions may be performed by pressing the front panel INPUT control, then rotating it to select the desired trim function for the current input. Use the VOLUME knob on the front panel to adjust the setting. The TRIM button on the remote control may be used to move through each trim function, while the LEVEL UP/LEVEL DN buttons control the selected function.* With each Trim menu, the information display returns to indicate the input selection and volume level after approximately 10 seconds.

Balance

Listening balance varies with different program sources, room acoustics, and listening positions relative to the loudspeakers. Use the balance to achieve equal volume levels in each loudspeaker.

```
L BALANCE R >
  ||
L BALANCE R >
  ■■■■■■
```

Input Trim Level

Source components can have slightly different volume levels, resulting in the need to readjust the MA2375 volume when switching between different sources. The MA2375 allows the adjustment of levels for each of the input sources for the same relative volume. Adjusting this setting changes the trim for the currently selected input.

```
< INPUT TRIM >
  < 0.0 dB >
< INPUT TRIM >
  < +6.0 dB >
```

Equalizer Mode

The built-in 5-band equalizer provides more precise adjustment of sound than standard bass and treble controls. By default, the equalizer is On for all input sources. Any input source may be assigned to have the equalizer On, or Off when selected.

```
< EQUALIZER >
  < On >
< EQUALIZER >
  Off >
```

Mono/Stereo Mode

Stereo allows separate left and right audio signals to be sent to their respective speaker. Mono sums the left and right audio signals before sending the same signal to each speaker. By default, the Stereo Mode is active for all inputs, however, any input source may be assigned to the Mono Mode of operation.

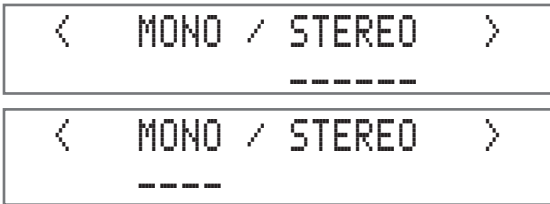

OUTPUT 1 & 2

The OUTPUT 1 setting is for loudspeakers connected to the power amplifier circuitry of the MA2375. The OUTPUT 2 setting is for an external power amplifier connected to the MA2375 rear panel OUTPUT 2 jacks. Select the appropriate setting for OUTPUT 1 and OUTPUT 2 settings, either On or Off.

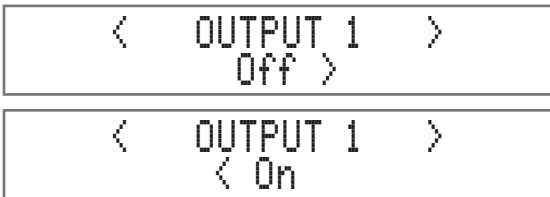

Sub Out

SUB OUT is designated for connecting subwoofers to the MA2375. By default, the SUB OUT setting is enabled.

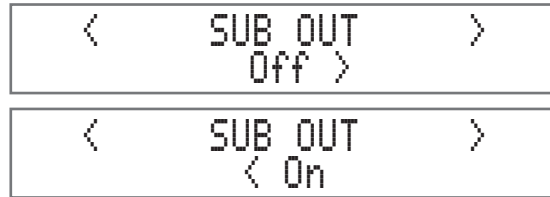

Meter Illumination

The meter illumination of the MA2375 may be switched On or Off as desired.

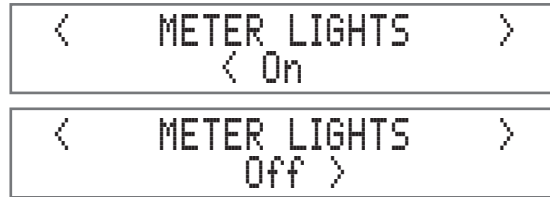

Tube Lights

The MA2375 vacuum tube illumination may be switched On or Off.

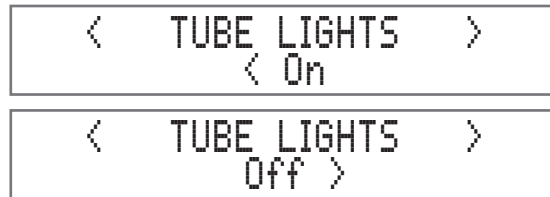

Display Auto Off

The information display of the MA2375 can be set to automatically turn off after a select period of time.



Information Display Brightness

The brightness level of MA2375 information display can be adjusted from bright to dim.



Headphone HXD

The Headphone HXD feature on the MA2375 appears when headphones are plugged into the front panel of the unit. The Headphone Crossfeed Director Circuitry can be turned On to create a sound-stage effect, making audio sound like it's coming from loudspeakers in front of the user.



Turntables With Built-In Preamps

Some turntables have built-in phono preamps, and are designed to be used with components without phono inputs. Many turntables with built-in preamps have a switch on the rear panel, or under the platter that allows the built-in preamp to be bypassed. If the built-in preamp cannot be bypassed, do not connect it to the phono inputs on the MA2375. Instead, connect the turntables left/right audio outputs to one of the unbalanced inputs.

One exception to this rule is if the turntable must be placed more than 10 ft (3 m) from the MA2375. Low level signals may pick up hum and noise if they travel down a longer audio cable. In such cases, use the preamp in the turntable and connect the turntable to an unbalanced input on the preamp, not the phono input.

Phono Input Connection and Setup

Connect the turntables left/right audio outputs and ground connection to the MA2375 phono input as shown in the Connection Diagram on page 8.

Determine the type of phono cartridge the turntable uses, the majority of phono cartridges fall into one of three categories.

Moving Magnet: The most common phono cartridge. Requires less gain than a moving coil cartridge, and a specific capacitive load.

Low Output Moving Coil: Requires the most gain compared to other cartridges, and a specific resistive load.

High Output Moving Coil: Requires more gain than a moving magnet cartridge, but less gain than a low output moving coil cartridge. Requires a specific resistive load.

Phono Trim Functions

When the phono input is selected, three extra settings will be available in the Trim menu—capacitance, resistance, and gain. When changing these settings, keep the turntables cartridge type in mind. It is important for the phono cartridge to be connected to a phono preamp with an input impedance (resistance and capacitance) the same as the cartridge load specifications. In addition, the gain must be set according to the output capability of the cartridge.

Capacitance

The capacitance setting adjusts the capacitive load the phono cartridge sees to optimize the phono preamp to the cartridge.

```
< CAPACITANCE >
      50pF >
```

Resistance

The resistance setting adjusts the resistive load the phono cartridge sees to optimize the phono preamp to the cartridge.

```
< RESISTANCE >
      < 47kΩ >
```

Gain

The gain setting controls how much the low level phono signal is amplified. The higher the dB, the more amplification.

```
< PHONO GAIN >
      40dB >
```

Moving Magnet

CAPACITANCE: Many modern phono cartridges are insensitive to changes in capacitance, and changing the setting may not alter the sound being output. Regardless, some moving magnet cartridges work best with a specific capacitive load. Check the specifications of the cartridge to determine its ideal capacitance. For example, if the cartridge specification says 300 pF is ideal, the capacitance should be set at 300 pF or lower. A lower setting will take the inherent capacitance in audio cables, which can add to the load, into account.

RESISTANCE: Almost all moving magnet phono cartridges are designed to work best into a resistance of 47k ohms. Unless a cartridge's specifications call for a different setting, set the preamp to provide 47k ohms of resistance.

GAIN: When using a moving magnet cartridge, start with the gain of the preamp at 40 dB. If the volume from the turntable is much lower than that of other sources in a system, the gain can be increased to 46 dB.

INPUT LEVEL TRIM: It's common for the volume level from a turntable to be lower than other sources, even after setting the phono preamp gain properly. The input trim adjustment in the MA2375 can be increased so that the phono input matches the level of other input sources.

See pages 12 & 13 for Trim menu instructions and options.

Low Output Moving Coil

CAPACITANCE: Low-output moving coil cartridges have a low output impedance, and are not sensitive to capacitance. Leave the capacitance at 50 pF.

RESISTANCE: Most low-output moving coil phono cartridges are designed to work best in a resistance between 100 and 400 ohms. Check the specifications of the phono cartridge being used to determine this. Some listeners may prefer to set the resistance "by ear" for their preferred sound. While playing a record with a wide range of instruments and voices, start with the resistance at 400 ohms, then decrease the resistance step-by-step until reaching the preferred sound. This is best done in the main listening position, using the remote control to access the Trim menu.

GAIN: When using a low-output moving coil cartridge, start with the gain of the phono preamp at 58dB. If the volume from the turntable is much lower than other sources in the system, the gain can be increased to 64 dB.

INPUT LEVEL TRIM: It's common for the volume level from turntable to be lower than higher level sources even after setting the preamp gain properly. The input trim adjustment in the MA2375 can be increased so the phono input matches the levels of other input sources.

See pages 12 & 13 for Trim menu instructions and options.

High Output Moving Coil

CAPACITANCE: High-output moving coil cartridges usually have a low output impedance, and are not sensitive to capacitance. Leave the capacitance at 50 pF.

RESISTANCE: Most high-output moving coil phono cartridges are designed to work best with a resistive load between 750 and 1k ohms. Check the specifications of the cartridge being used for the ideal resistance setting. Some listeners may prefer to set the resistance "by ear" for their preferred sound. While playing a record with a wide range of instruments and voices, start with the resistance at 1k ohms, then decrease the resistance step-by-step until reaching the preferred sound. This is best done in the main listening position, using the remote control to access the Trim menu.

GAIN: When using a high-output moving coil cartridge, start with the gain of the phono preamp at 46 dB. If the volume the turntable is much lower than other sources in a system, the gain can be increased to 52 dB.

INPUT LEVEL TRIM: It's common for the volume level from turntable to be lower than higher level sources even after setting the preamp gain properly. The input trim adjustment in the MA2375 can be increased so the phono input matches the levels of other input sources.

See pages 12 & 13 for Trim menu instructions and options.

Setup Menus

Submenus	Settings
System	Product Information, Firmware, PassThru, Auto Off, Factory Reset
Inputs	Enabled, Name
Outputs	Output 1, Output 2, Sub Out, Headphones
Data Ports	Port 1, Port 2
External Control	Front IR, IR Codes, RS232

Setup Menu Navigation

The McIntosh MA2375 has been factory configured to allow immediate enjoyment of superb audio without the need for further adjustments. If changes must be made to the factory default settings, a Setup menu is provided to customize the operating settings using the front panel display.

To access the Setup menu, press and hold the INPUT knob on the front panel until the information display indicates the following:

```
Setup: Menu Select
      System >
```

Using the INPUT knob, navigate through the submenus by rotating, and select by pressing the knob in. Once the desired submenu has been selected, rotate the INPUT knob to navigate through the submenu settings. To change the selected setting, rotate the VOLUME knob. Exit the Setup menu by rotating the INPUT knob to Exit selection.

System Setup Submenu

Settings	Options
Product	MA2375 - (serial number)
Firmware	(current firmware version)
PassThru	Disabled , BAL 1-2, UNBAL 1-3
Power	Auto Off , Always On
Factory	(restore factory default settings)

Note: Bold options indicate default settings

Product Information

Specific identifying information for the MA2375 is shown in the Product menu.

Firmware

The current firmware version will be displayed here.

PassThru

When the MA2375 is part of a home theater, or multichannel audio system, the right and left front channels from an audio/video processor, or surround decoder can “PassThru” the MA2375 and into its associated power amplifier(s). The PassThru setting allows selection of the specified MA2375 input to be used for the right and left front channels.

```
System: < Passthru >
      Disabled >
```

Power

Auto Off: The MA2375 will automatically enter sleep mode after approximately 20 minutes without user activity, or an audio signal.

Always On: The MA2375 must be turned off by pressing the POWER button on the front panel, or the red  button on the remote control.

```
System: < Power >
      Auto Off >
```

Factory Reset

To reset all adjustable settings to their factory default, select factory reset. Hold in the INPUT knob to reset the unit.

```
System: < Factory >
Hold INPUT to Reset
```

Input Setup Submenu

Settings	Options
Enable	Off, On
Name	

Enable

By default, all inputs are On. Unused inputs can be turned Off so that they do not appear on the display during input selection. Rotate the VOLUME knob to turn the selected input On or Off.

Rename

Inputs can be renamed to more accurately reflect the source component that it is associated with. Rotate the INPUT knob so that the display says “Input: Name, Rename Input” and press the INPUT knob to begin renaming.

```
Input: < Name >
Rename Input
```

A blinking cursor will appear over the selected character of the input’s name. Rotate the INPUT knob to select which character to change, and use the VOLUME knob to change the character. Once the new name has been entered, hold the INPUT knob to confirm. Otherwise, a press and release of the INPUT knob will return the display to the previous menu without applying the changes.

Output Setup Submenu

Settings	Options
Output 1	Switched, Unswitched
Output 2	Switched, Unswitched
Sub Out	Switched, Output 1-2, Unswitched
Headphones	Mute All Outputs, Mute No Outputs

Outputs 1 and 2

The output setup menu provides the ability to change how Output 1, Output 2, Sub Out, and Headphones function. Each output can be independently configured to operate in one of several modes. Each output is set to Switched by default, which allows toggling using the OUTPUT 1 and OUTPUT 2 buttons on the remote control. Output cannot be turned off when Unswitched.

```
Output:  OUTPUT 1 >
        Switched >
```

Sub Out

Like Outputs 1 and 2, Sub Out is automatically Switched. Selecting the Output 1 or Output 2 options make Sub Out mirror what is done on the selected output. For example, if Output 1 is selected and turned off, Sub Out will follow.

```
Output: < SUB OUT >
        Switched >
```

Headphones

By default, the Mute All Outputs setting is turned on, muting all outputs upon plugging in headphones unless they are setup as Unswitched. Selecting the Mute No Outputs option wont turn off any outputs when headphones are plugged in.

Data Ports Setup Submenu

Settings	Options
Port 1	All Data, BAL 1-2 UNBAL 1-3
Port 2	All Data, BAL 1-2 UNBAL 1-3

Data port connections between the MA2375 and a McIntosh source component allow basic function control of the source component using the MA2375 supplied HR085 remote control. By default, the two data ports are set to send the same data to the selected source. To dedicate a given data port for only one source component select the desired output.

```
SETUP: Menu Select
< Data Ports >
```

```
Data Port:  1 >
< UNBAL 1 >
```

External Control Setup Submenu

Settings	Options
Front IR	Enabled, Disabled
IR Codes	Normal, Alternate
RS232	9600, 19200, 38400, 57600, 115200 Baud

Front IR

The MA2375 front panel sensor, which receives the signals from the HR085 remote control, can be Disabled to prevent interference when an external IR sensor is connected.

```
Ext Ctrl:  Front IR >
< Enabled
```

```
Ext Ctrl:  Front IR >
          Disabled >
```

IR Codes

The remote control included with the MA2375 utilizes the normal McIntosh control codes. The second set of control codes the MA2375 will respond to is referred to as the Alternate Codes. The Alternate Codes are used when the MA2375 is used in the same location as another McIntosh preamplifier and/or A/V processor. This will prevent the remote control from affecting the operation of both units at the same time.

```
Ext Ctrl: < IR Codes >
          Normal >
```

It is now necessary to change the HR085 remote control over to the Alternate Codes.

RS232

The MA2375 may be remotely controlled from other equipment connected to the rear panel RS232 port. The speed at which the MA2375 communicates (8 bit, no parity, and 1 stop bit) with other equipment is adjustable from 9,600 Baud (bits per second) to 115,200 Baud.

```
Ext Ctrl: < RS232 >
          < 115200 Baud
```

Resetting the Microprocessors

In the unlikely event the controls of the MA2375 stop functioning, the microprocessor can be reset

1. Press and hold in the front panel VOLUME knob until the standby LED switches off.
2. Release the VOLUME knob, and the MA2375 will switch off.
3. When the STANDBY/ON LED is illuminated press the VOLUME knob, and the MA2375 will resume normal operation.

Specifications

*Factory default phono settings.

FTC Power Output Rating

75 watts

Rated Output

Output 1: 75 watts

Output 2: 1.7 V

Sub: 1.7 V

Output 1 Load Impedance

4, 8, or 16Ω

Rated Power Band

20 Hz to 20k Hz

Total Harmonic Distortion

0.5% maximum with both channels operating from 250 milliwatts to rated power, 20 Hz to 20k Hz

Intermodulation Distortion

0.5% maximum, if the instantaneous peak power output does not exceed twice the rated power output for any combination of frequencies from 20 Hz to 20k Hz

Dynamic Headroom

1.2 dB

Wide Band Damping Factor

Greater than 22

Frequency Response

+0, -0.5 dB from 20 Hz to 20k Hz

+0, -3 dB from 10 Hz to 50k Hz

Preamplifier Output Impedance

100Ω

Sensitivity (for rated output)

Unbalanced: 300m V

Balanced: 600m V

Phono: 3m V*

Signal To Noise Ratio (A-Weighted)

Unbalanced: 95 dB below rated output

Balanced: 95 dB below rated output

Phono: 75 dB below rated output*

Input Impedance

Unbalanced: 22kΩ

Balanced: 44kΩ

Phono: 100 - 47kΩ; 50 - 400pF

Maximum Input Signal

Unbalanced: 5 V

Balanced: 10 V

Phono: 80m V*

Voltage Gain

High Level to Output 1: 38 dB (8Ω)

High Level to Output 2: 15 dB

Phono to Output 1: 78 dB (8Ω)*

Phono to Output 2: 55 dB*

Headphone Load Impedance

100 to 600 ohms

Trigger Output

12VDC, 25mA

Equalizer Controls

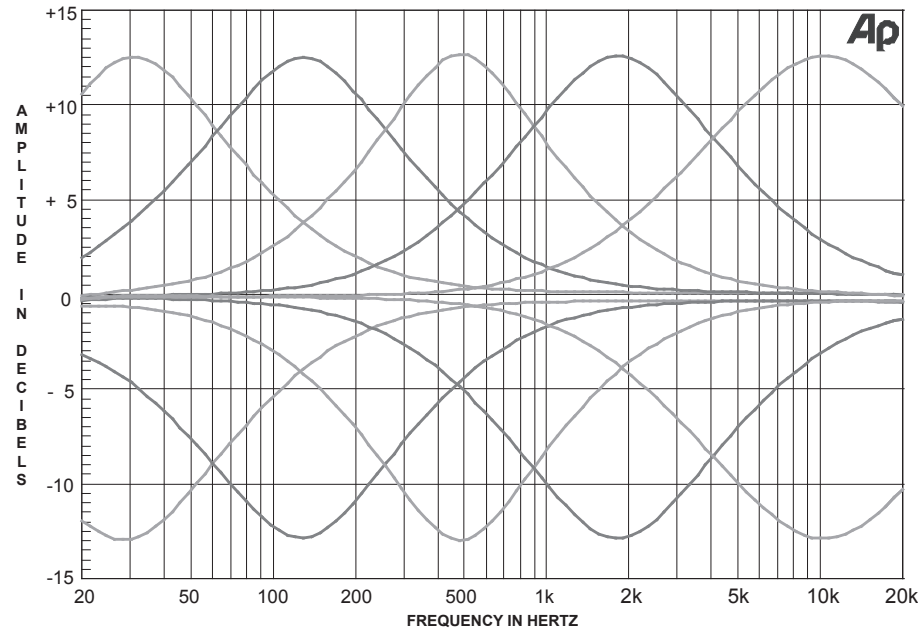

Power Requirements

Field AC voltage conversion of the MA2375 is not possible. The MA2375 is factory configured for one of the following AC voltages:

100 Volts, 50/60Hz at 4.4 amps

110 Volts, 50/60Hz at 3.6 amps

120 Volts, 50/60Hz at 3.6 amps

220 Volts, 50/60Hz at 2.0 amps

230 Volts, 50/60Hz at 1.8 amps

240 Volts, 50/60Hz at 1.8 amps

Standby: Less than 0.25 watt

Note: Refer to the rear panel of the MA2375 for the correct voltage.

Overall Dimensions

Width: 17¹³/₁₆ inches / 45.2 cm

Height: 9⁵/₁₆ inches / 25.2 cm

Depth: 20⁷/₁₆ inches / 51.9 cm

Weight

Net: 93 pounds / 42.2 kg

In shipping carton: 103 pounds / 46.7 kg

Shipping Carton Dimensions

Width: 23¹/₄ inches / 59.1 cm

Depth: 25¹/₄ inches / 64.1 cm

Height: 14¹/₂ inches / 36.8 cm

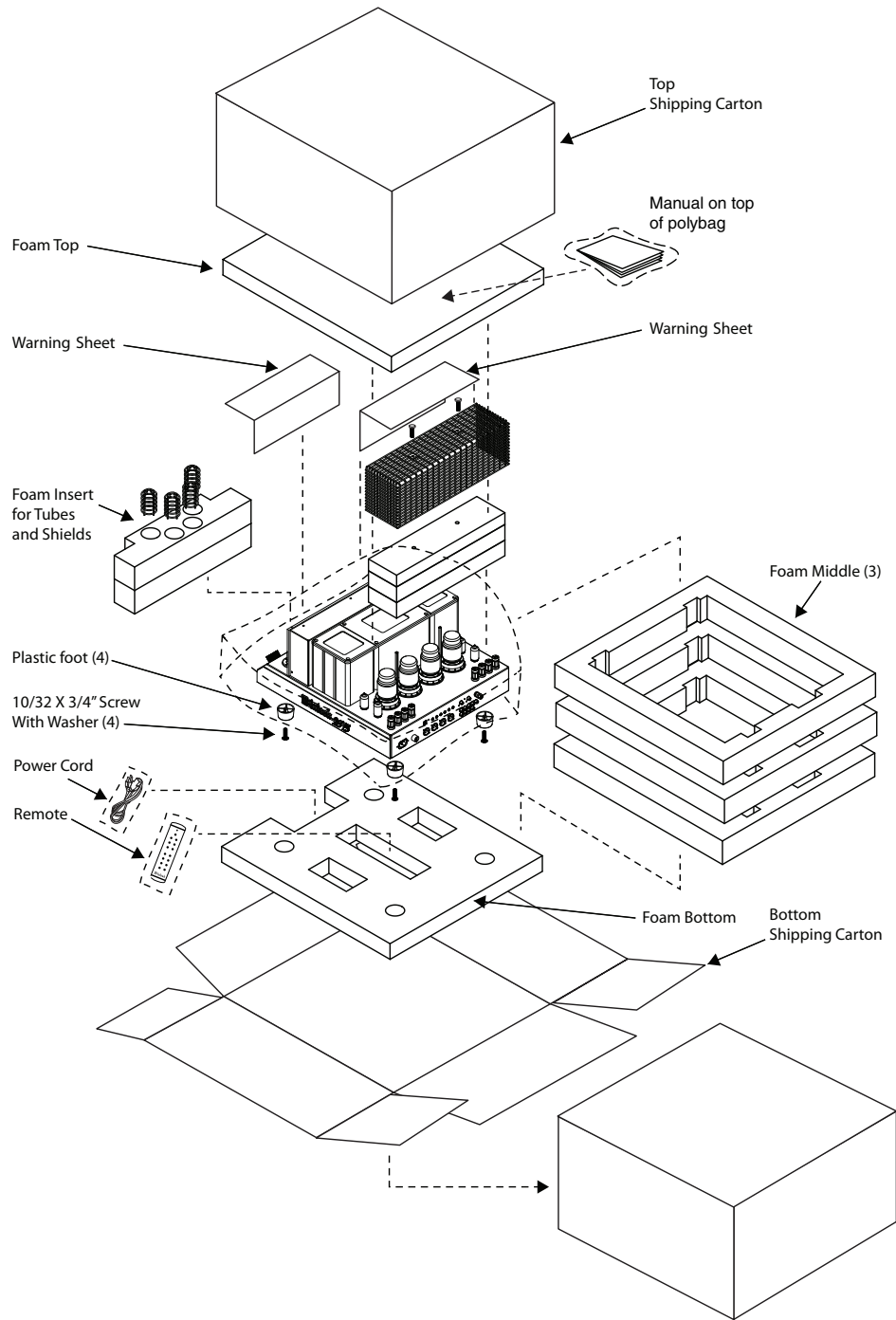

Packing Instructions

In the event it is necessary to repack the equipment for shipment, the equipment must be packed exactly as shown. **It is very important that the four feet are attached to the bottom of the equipment. This will ensure the proper equipment location on the foam bottom. Failure to do this will result in shipping damage.**

To protect the tubes during shipment, the foam inserts removed from the MA2375 need to be re-inserted. Follow the Foam Removal instructions on pages 3-4 in the reverse order.

Use the original shipping carton and interior parts only if they are all in good, serviceable condition. If a shipping carton or any of the interior part(s) are needed, please call or write Customer Service Department of McIntosh Laboratory, refer to page 2.

MA2375 Packing Material List

Quantity	Part Number	Description
1	034783	Shipping carton top
1	753041	Manual package
1	034750	Foam top
3	034751	Foam middle
1	033739	Poly bag
2	241109	Warning sheet
1	034747	Foam tube front
1	034748	Foam tube rear
4	017937	Plastic foot
4	404080	#10 flat washer
4	400159	#10-32 x 3/4 inch screw
1	HR085	Remote control
1	Note 1	AC power cord
1	034785	Foam bottom
1	034784	Shipping carton bottom

Note! AC power cords are country specific

McIntosh®

MADE OF SOUND™

McIntosh Laboratory, Inc.
2 Chambers Street
Binghamton, NY 13903
www.mcintoshlabs.com

The continuous improvement of its products is the policy
of McIntosh Laboratory Incorporated
who reserve the right to improve design without notice.

Trademarks of McIntosh Laboratory, Inc.:

The following are Registered Trademarks of McIntosh Laboratory, Inc in multiple jurisdictions around the world: the written McIntosh logo; the McIntosh Globe logo; the Mc logo; Power Guard; Power Guard Screen Grid Sensor; Power Guard SGS; LD/HP; Dynamic Power Manager; the 4DPM8 logo; HXD; the HXD logo; Behind The Sound; Legendary Performance.

The following are Trademarks of McIntosh Laboratory, Inc. in multiple jurisdictions around the world: Autoformer; Sentry Monitor; Solid Cinch; McIntosh Monogrammed Heatsinks; Hybrid Drive; DualView; TripleView; Made of Sound.

The foregoing trademarks, registered and otherwise, are not to be used, reproduced, or registered in any way without the express written permission of McIntosh Laboratory, Inc.