

# VIA PERIMETER 3-5

## END SLEEVE ADJUSTMENT INSTRUCTION

**IMPORTANT:** Installation instructions are shown with Via Perimeter 3 and applies to all Via Perimeter sizes

**NOTE:** Wire dimming conductors as Class 1



Before you start, measure your opening to determine the exact dimension

DO NOT cut LED board, LED board in sleeve will easily slide over LED board in extrusion.



A miter saw is **REQUIRED** for **ON SITE** sleeve adjustment

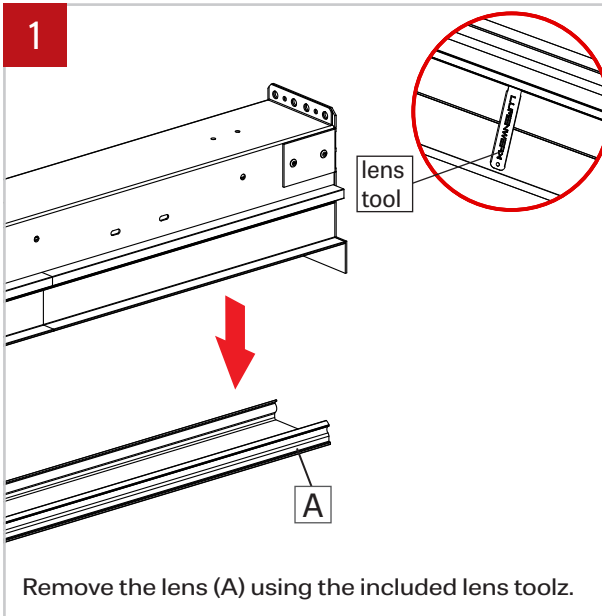

Remove the lens (A) using the included lens tool.

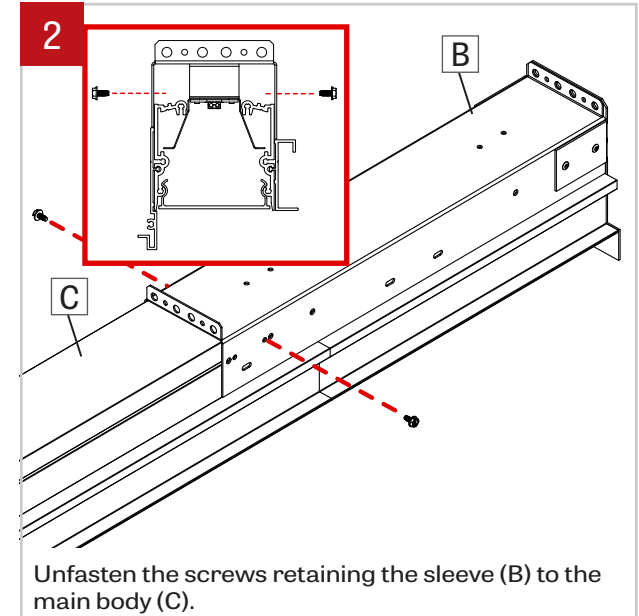

Unfasten the screws retaining the sleeve (B) to the main body (C).

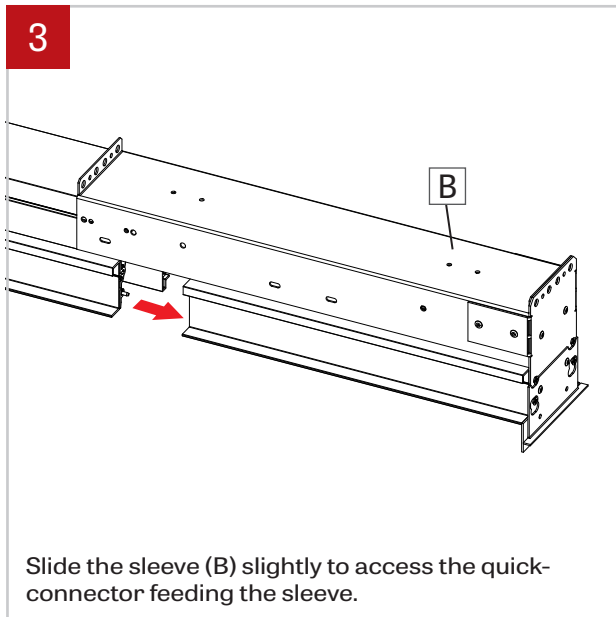

Slide the sleeve (B) slightly to access the quick connector feeding the sleeve.

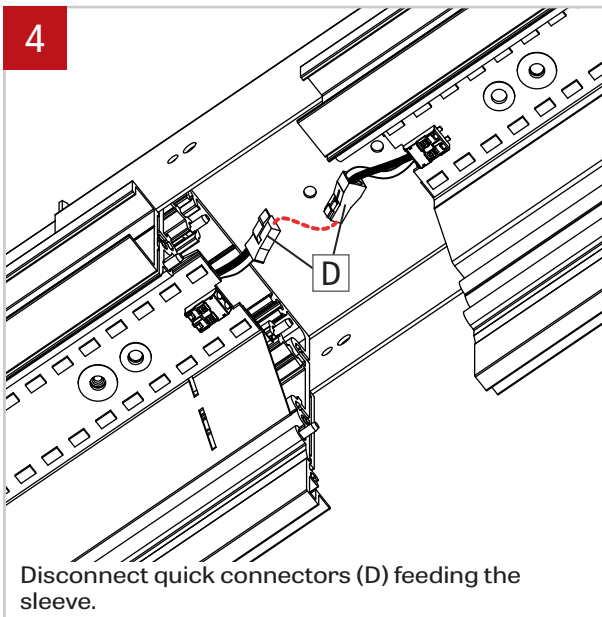

Disconnect quick connectors (D) feeding the sleeve.

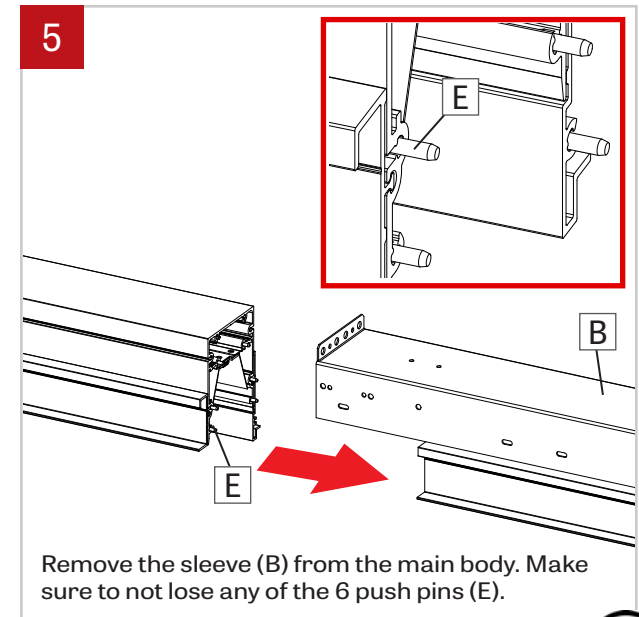

Remove the sleeve (B) from the main body. Make sure to not lose any of the 6 push pins (E).

# VIA PERIMETER 3-5

## END SLEEVE ADJUSTMENT INSTRUCTION

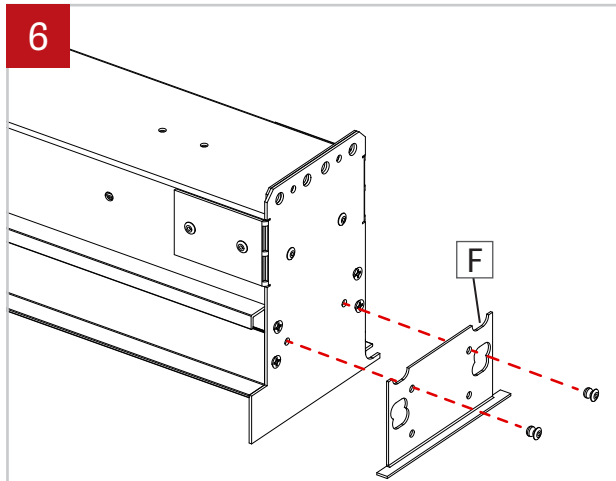

**OPTIONAL:** If the fixture is mounted flush to the wall, take out the end cap's flange (F) by removing the rivets.

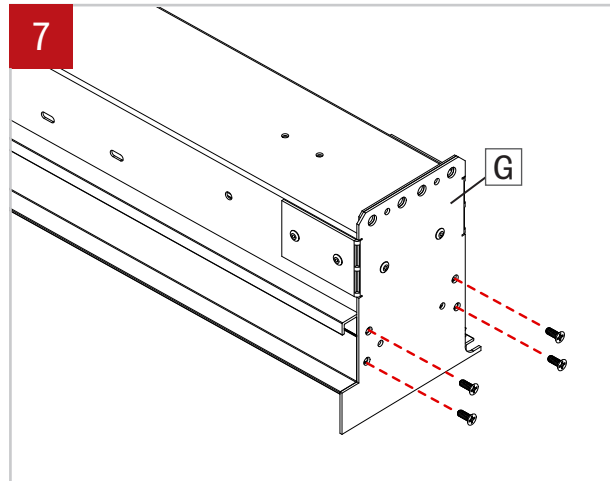

Remove the screws on the sleeve's end cap (G).

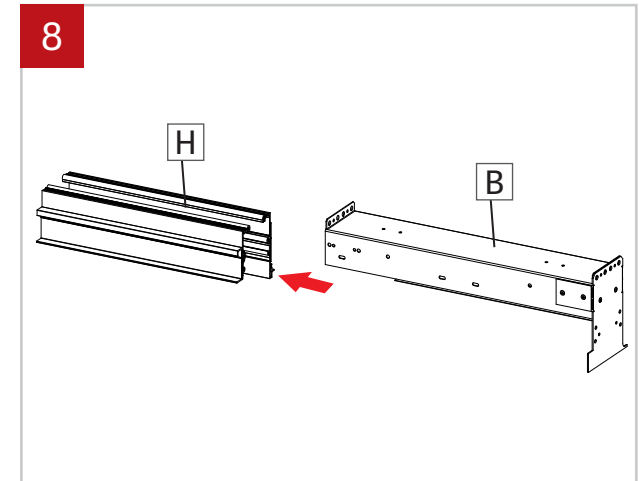

Remove the extrusions (H) from the sleeve base (B).

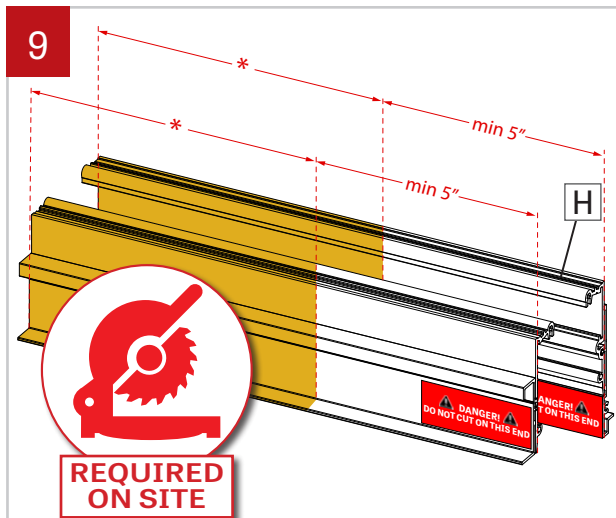

Using a Miter Saw, cut the extrusions (H) to the required length **on the opposite side of the labels**. **They can't be cut shorter than 5".**

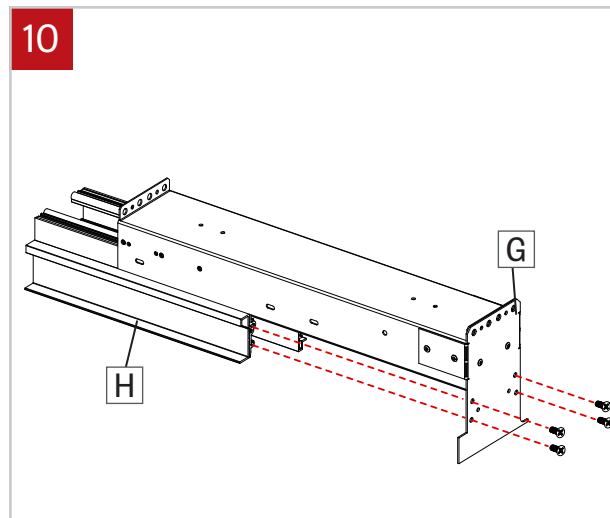

Slide the cut extrusions (H) all the way to the end cap (G). Put the screws back on the end cap (G).

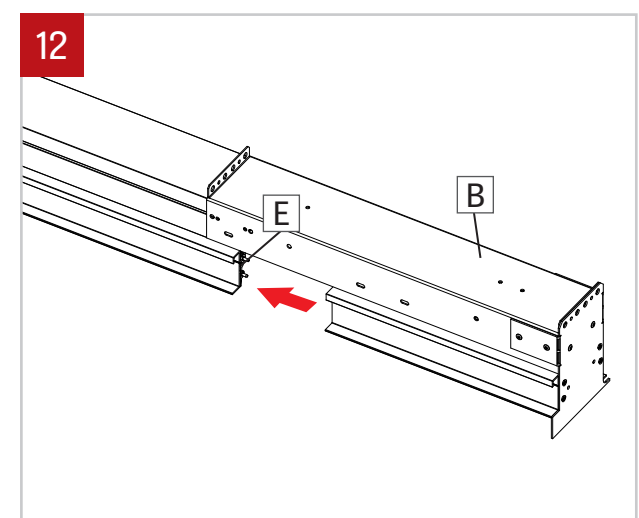

Make sure that all the push pins (E) are still on the main extrusion. Slide the sleeve (B) back in the main body. Do not slide all the way to the end.

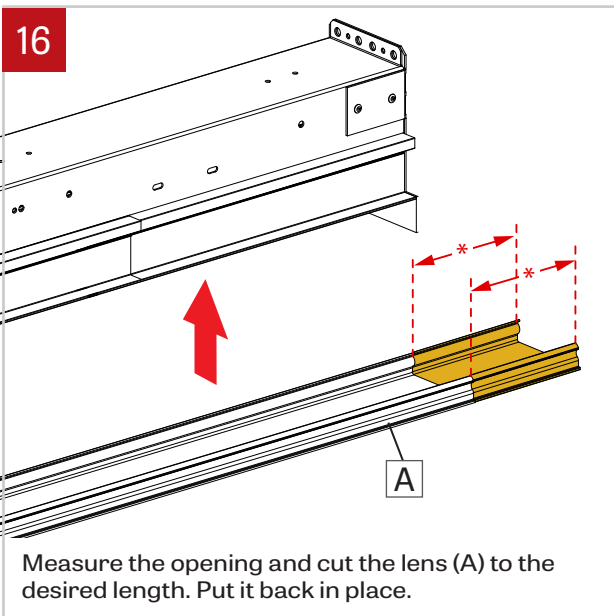
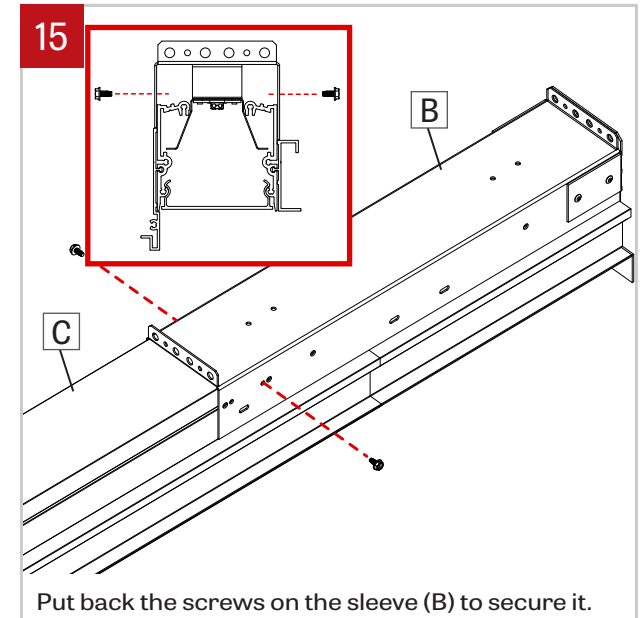
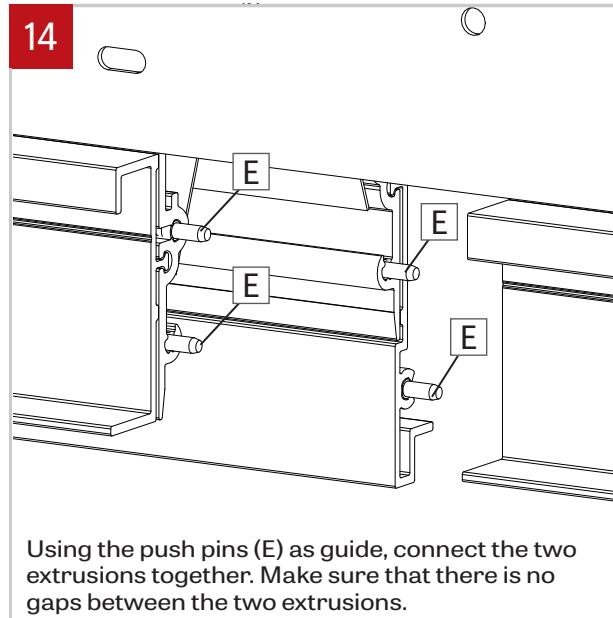
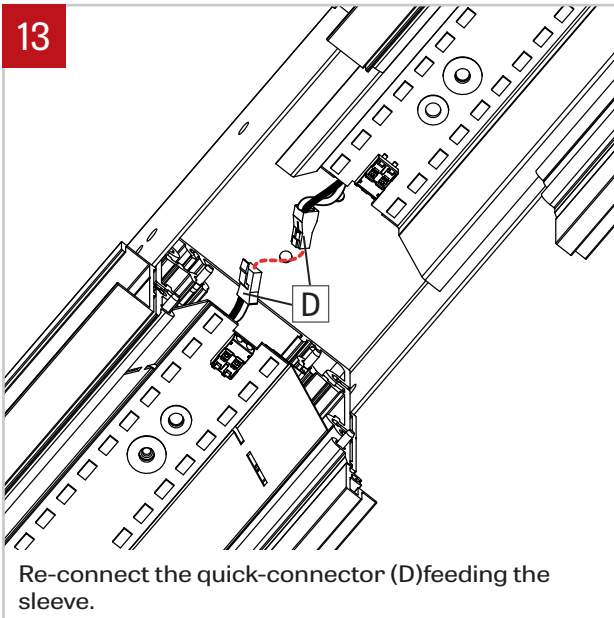

**You are ready to proceed to your installation. Please refer to the proper installation instructions according to your fixture's mounting.**