

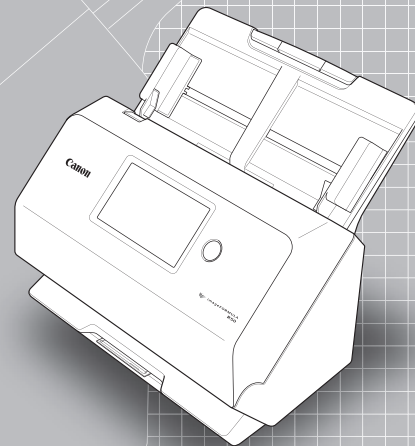

User Manual

- Please read this manual before operating this scanner.
- After you finish reading this manual, store it in a safe place for future reference.



FCC REGULATIONS (For 120 V model)

Document Scanner, Model 6130210

NOTE: This equipment has been tested and found to comply with the limits for a Class B digital device, pursuant to part 15 of the FCC Rules. These limits are designed to provide reasonable protection against harmful interference in a residential installation. This equipment generates, uses and can radiate radio frequency energy and, if not installed and used in accordance with the instructions, may cause harmful interference to radio communications. However, there is no guarantee that interference will not occur in a particular installation. If this equipment does cause harmful interference to radio or television reception, which can be determined by turning the equipment off and on, the user is encouraged to try to correct the interference by one or more of the following measures:

- Reorient or relocate the receiving antenna.
- Increase the separation between the equipment and receiver.
- Connect the equipment into an outlet on a circuit different from that to which the receiver is connected.
- Consult the dealer or an experienced radio/TV technician for help.

Use of a shielded cable is required to comply with Class B limits in Subpart B of Part 15 of the FCC Rules.

Do not make any changes or modifications to the equipment unless otherwise specified in the manual. If such changes or modifications should be made, you could be required to stop operation of the equipment.

Changes or modifications not expressly approved by the party responsible for compliance could void the user's authority to operate the equipment.

This transmitter must not be co-located or operated in conjunction with any other antenna or transmitter.

This equipment complies with FCC radiation exposure limits set forth for an uncontrolled environment and meets the FCC radio frequency (RF) Exposure Guidelines as this equipment has very low levels of RF energy. But it is desirable that it should be installed and operated keeping the radiator at least 20cm or more away from person's body.

Canon U.S.A. Inc.

One Canon Park, Melville, NY 11747, U.S.A.

Tel. No. 1-800-OK-CANON (1-800-652-2666)

ISED REGULATIONS (For 120 V model)

This device contains licence-exempt transmitter(s)/receiver(s) that comply with Innovation, Science and Economic Development Canada's licence-exempt RSS(s). Operation is subject to the following two conditions: (1) This device may not cause interference. (2) This device must accept any interference, including interference that may cause undesired operation of the device.

This equipment complies with ISED radiation exposure limits set forth for an uncontrolled environment and meets RSS-102 of the ISED radio frequency (RF) Exposure rules. This equipment has very low levels of RF energy that it deemed to comply without maximum permissive exposure evaluation (MPE). But it is desirable that it should be installed and operated keeping the radiator at least 20cm or more away from person's body.

ENERGY STAR® Office Equipment Program



This program is for U.S.A and Canada. As an ENERGY STAR® Partner, CANON ELECTRONICS INC. has determined that this machine meets the ENERGY STAR® Program guidelines for energy efficiency.

The ENERGY STAR® Office Equipment Program is an international program that promotes energy saving through the use of computers and other office equipment. The program backs the development and dissemination of products with functions that effectively reduce energy consumption. It is an open system in which business proprietors can participate voluntarily. The targeted products are office equipment, such as computers, monitors, printers, fax, machine, copiers, and scanners. The standards and logos are uniform among participating nations.

This model doesn't provide setting options for power management.

Only for European Union and EEA (Norway, Iceland and Liechtenstein)



This symbol indicates that this product is not to be disposed of with your household waste, according to the WEEE Directive (2012/19/EU) and national legislation. This product should be handed over to a designated collection point, e.g., on an authorized one-for-one basis when you buy a new similar product or to an authorized collection site for recycling waste electrical and electronic equipment (EEE). Improper handling of this type of waste could have a possible negative impact on the environment and human health due to potentially hazardous substances that are generally associated with EEE. At the same time, your cooperation in the correct disposal of this product will contribute to the effective usage of natural resources. For more information about where you can drop off your waste equipment for recycling, please contact your local city office, waste authority, approved WEEE scheme or your household waste disposal service. For more information regarding return and recycling of WEEE products, please visit www.canon-europe.com/weee.

Model Names

The following name may be provided for the safety regulations in each sales region of the Document Scanner.

R50: Model 6130210

Reproduction Warning

This device is designed to be used in a legal manner, in accordance with all applicable laws, including, but not limited to, counterfeit and copyright laws, as well as laws pertaining to national security. Any person(s) found to have reproduced any of the following materials (regardless of whether such reproduction was intentional or not) for the purpose of misrepresenting such material as the original may be prosecuted in accordance with the applicable laws and regulations.

- Paper money or bank notes (domestic and foreign)
- Postage stamps, revenue stamps, or other similar stamps
- Stock certificates, bond certificates, promissory notes, cheques, or other valuable certificates
- Passports, licenses, or other certificates or documents issued by government officials or agencies

This is not an exhaustive list.

Canon is not responsible for how this scanner is used by an individual. Please note that certain intellectual property is protected by copyright law, and copyrighted items may not be reproduced without the express permission of the copyright holder except for personal or household use under limited circumstances.

Para consultas, visite: www.anatel.gov.br

Este equipamento não tem direito à proteção contra interferência prejudicial e não pode causar interferência em sistemas devidamente autorizados



04046-16-07857

This telecommunication equipment is in compliance with NBTC requirements

Trademarks

- Canon and the Canon logo are registered trademarks, of Canon Inc. in the United States and may also be trademarks or registered trademarks in other countries.
- imageFORMULA is a trademark of CANON ELECTRONICS INC.
- Microsoft, Windows, PowerPoint, and SharePoint are registered trademarks or trademarks of Microsoft Corporation in the United States and other countries.
- Microsoft product screen shot(s) reprinted with permission from Microsoft Corporation.
- ENERGY STAR® is a registered trademark of the United States Environmental Protection Agency.
- macOS is a trademark of Apple Inc., registered in the U.S. and other countries.
- Wi-Fi, Wi-Fi Alliance, the Wi-Fi CERTIFIED logo and the Wi-Fi Protected Setup logo are registered trademarks of the Wi-Fi Alliance.
- Wi-Fi CERTIFIED, WPA, WPA2 and Wi-Fi Protected Setup are trademarks of the Wi-Fi Alliance.
- “WPS” in the settings, onscreen displays and in this manual denotes Wi-Fi Protected Setup.
- Other product and company names herein may be the trademarks of their respective owners. However, the TM and ® symbols are not used in this document.

Copyright

Copyright 2020 by CANON ELECTRONICS INC. All rights reserved. No part of this publication may be reproduced or transmitted in any form or by any means, electronic or mechanical, including photocopying and recording, or by any information storage or retrieval system without the prior written permission of CANON ELECTRONICS INC.

Disclaimers

The information in this document is subject to change without notice.

CANON ELECTRONICS INC. MAKES NO WARRANTY OF ANY KIND WITH REGARD TO THIS MATERIAL, EITHER EXPRESS OR IMPLIED, EXCEPT AS PROVIDED HEREIN, INCLUDING WITHOUT LIMITATION, THEREOF, WARRANTIES AS TO MARKETABILITY, MERCHANTABILITY, FITNESS FOR A PARTICULAR PURPOSE OF USE OR NON-INFRINGEMENT. CANON ELECTRONICS INC. SHALL NOT BE LIABLE FOR ANY DIRECT, INCIDENTAL, OR CONSEQUENTIAL DAMAGES OF ANY NATURE, OR LOSSES OR EXPENSES RESULTING FROM THE USE OF THIS MATERIAL.

CANON ELECTRONICS INC. IS NOT LIABLE FOR THE STORAGE AND HANDLING OF DOCUMENTS SCANNED WITH THIS PRODUCT, OR THE STORAGE AND HANDLING OF RESULTING SCANNED IMAGE DATA.

IF YOU INTEND TO DISCARD THE ORIGINALS OF SCANNED DOCUMENTS, YOU THE CUSTOMER ARE RESPONSIBLE FOR INSPECTING THE SCANNED IMAGES AND VERIFYING THAT DATA IS INTACT.

THE MAXIMUM LIABILITY OF CANON ELECTRONICS INC. UNDER THIS WARRANTY IS LIMITED TO THE PURCHASE PRICE OF THE PRODUCT COVERED BY THE WARRANTY.

Introduction

Thank you for purchasing the Canon imageFORMULA Document Scanner.

Please read the following manuals carefully and familiarize yourself with the functions of the scanner before use to ensure you sufficiently understand the functions and make the most of the scanner's capabilities. After reading the manuals, store them in a safe place for future reference.

Manuals for the Scanner

Documentation for this scanner consists of the following manuals.

- **Product Safety Guide**

Before using the scanner, be sure to read and follow these instructions.

- **Setup Guide**

This describes setup procedures for the scanner. Read this manual when you first use the scanner.

- **User Manual (this manual)**

This manual contains the operating procedures of the scanner. (PDF electronic manual only)

Windows

If you are using Windows, the User Manual (electronic manual) will be registered to the following location when the software is installed.

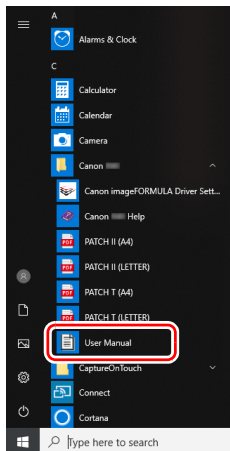

Hint

In Windows 8.1, it is registered at the following location.

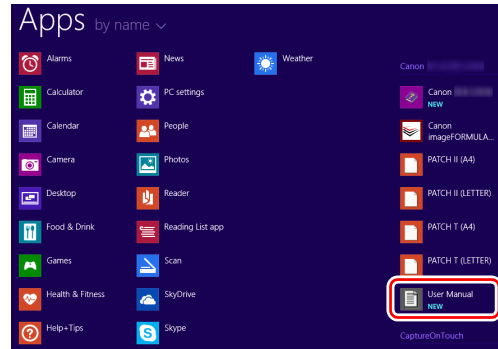

Mac

The User Manual (electronic manual) will be registered to the following location.

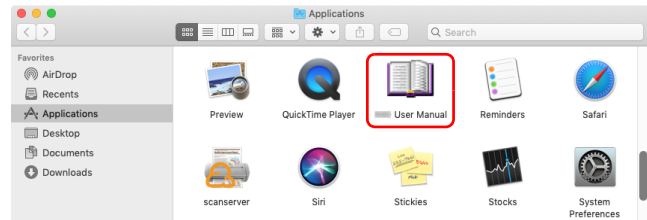

Symbols Used in This Manual

The following symbols are used in this manual to explain procedures, restrictions, handling precautions, and instructions that should be observed for safety.



WARNING

Indicates a warning concerning operations that may lead to death or injury to persons if not performed correctly. To use the scanner safely, always pay attention to these warnings.



CAUTION

Indicates a caution concerning operations that may lead to injury to persons, or damage to property if not performed correctly. To use the scanner safely, always pay attention to these cautions.



IMPORTANT

Indicates operational requirements and restrictions. Be sure to read these items carefully to operate the scanner correctly, and avoid damaging the scanner.



Hint

Indicates a clarification of an operation, or contains additional explanations for a procedure. Reading these notes is highly recommended.

Table of Contents

Introduction	5	One Touch Scan	44
Symbols Used in This Manual.....	6	Standard Scanning.....	48
Before Using the Scanner.....	9	Scanning from the Scanner Touch Panel.....	50
System Requirements of Software.....	9	Setting the Scanner Driver	52
Turning the Power ON.....	10	Configuration and Functions of the Scanner Driver	52
Turning Off the Power.....	10	Setting Basic Scanning Conditions	55
Important Safety Instructions	12	More Advanced Scanning Methods	
Installation Location	12	(Batch Separation)	74
AC Adapter.....	12	Batch Separation (Insert blank page).....	74
Moving the Scanner	13	Batch Separation Using Patch Code Sheets.....	74
Handling	13	Web Menu	77
Disposal	14	Using the Web Menu	77
When sending the scanner for repairs	14	Displaying the Scanner's Web Menu	77
About wireless communication functions	14	Web Menu Pages.....	79
About the radio waves.....	14	Web Menu Settings	80
Features of the Scanner	17	Scanner Name Setting	80
Names and Functions of Parts	20	Network Setting	80
Basic Operation	25	Device Configuration	81
Documents	25	Password Setting	85
How to Place Documents	27	Maintenance Setting.....	86
Scanning multiple documents	27	Maintenance	87
Placing Cards.....	28	Daily Maintenance	87
Setting the Long Document Mode.....	29	Cleaning the Scanner.....	87
Detecting a document double feed	31	Cleaning the touch panel.....	87
Operating the Settings Menus	35	Cleaning the Inside of the Scanner	87
About the Settings Menus.....	35	Cleaning the Sensor Glass and the Rollers	87
Procedure to operate the settings menu	35	Replacing Consumable Parts.....	90
Functions in the Settings Menus.....	37	Removing the Document Feed Tray	94
Device Settings	37	About the Canon imageFORMULA Driver Setting Tool	94
Maintenance.....	37	Troubleshooting	96
Connect Settings.....	38	Common Problems and Solutions.....	96
Scan Setting.....	39	Software Troubleshooting.....	100
Scanning.....	40	Useful Tips	101
Scanning Using a Computer (CaptureOnTouch)	41	Clearing a Paper Jam.....	103
Starting and Exiting CaptureOnTouch	41	Error Message	106
Selecting a scanner.....	42	Uninstalling the Software	107
Screen Descriptions	43	Uninstalling the TWAIN Driver.....	107

Appendix	108
Specifications.....	108
Replacement parts	109
Dimensions	109
Index.....	110

System Requirements of Software

To use the scanner, your computer must satisfy the following system requirements.

Computer

CPU:	Intel Core 2 Duo 1.66GHz or faster Windows Intel Core i7 2.3GHz or faster Mac
Memory:	1 GB or more Windows 8 GB or more Mac
Hard disk:	3 GB or more available space required for installation of all software
USB interface:	USB 3.2 Gen1x1/ USB2.0
Monitor:	Resolution of 1024 × 768 (XGA) or better recommended.

Operating system

- Microsoft Windows 8.1 (32-bit and 64-bit editions)
- Microsoft Windows 10 (32-bit and 64-bit editions)
- Microsoft Windows Server 2012 R2
- Microsoft Windows Server 2016
- Microsoft Windows Server 2019
- macOS 10.13
- macOS 10.14
- macOS 10.15

This is the environment as of June 2020.

For the latest software support information, go to the Products page on the Canon website.

Other requirements

- A TWAIN-compatible application that is compatible with the above operating systems.
- .NET Framework 4.5 or later
- CaptureOnTouch V.4.2.3019 or later

IMPORTANT

- Use the USB interface provided as standard with your computer. However, normal operation is not guaranteed with all USB interfaces, even if present as standard equipment on the computer. For details, consult your local authorized Canon dealer.
- Scanning speeds are lower if your computer's standard USB interface is USB Full-Speed (equal to USB 1.1.)
- The USB cable you are using should be the one originally included with the scanner.
- If the CPU, memory, interface card, and other specifications do not satisfy the installation requirements, the scanning speed may be greatly reduced and transmission may take a long time.
- Even if the computer satisfies the system requirements, the scanning speed may vary, depending on the specification of the computer and the environment.
- The scanner drivers provided with the scanner do not necessarily operate on all TWAIN-compatible applications. For details, contact your application software retailer.
- In Windows 10 tablet mode, the software may disrupt the display.
- The Desktop Experience feature must be enabled for Windows Server 2012 R2.

Precautions for Use in 64-bit Operating Systems (Windows only)

Scanning speed may vary depending on the specifications of your computer.

Turning the Power ON

The power of the scanner can be turned ON and OFF with the power button on the front of the scanner.

1 Make sure that the scanner and computer are connected properly.

2 Press the power button.

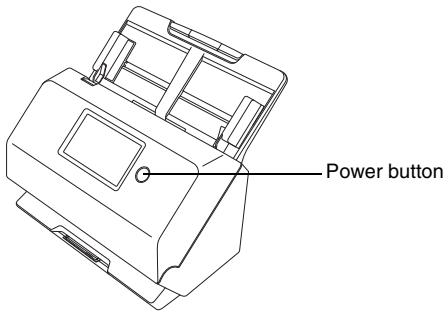



The power button lights blue when the power turns ON.

Windows

Hint

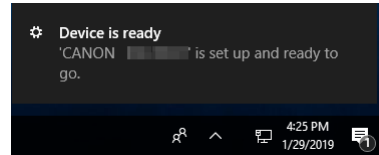
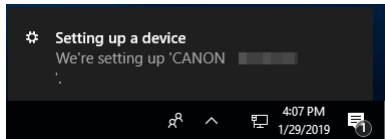
When connected via USB, a balloon message such as shown below appears on the task bar. If you wait a while, automatic scanner recognition will end and the scanner will become ready to use.



When the scanner is properly connected to the computer, the  (CaptureOnTouch) icon appears on the taskbar as follows.



If the taskbar icon appears as , the scanner is not properly connected to the computer. Check the status of the power switch and USB cable.

Mac

When the scanner is properly connected to the computer, the  (CaptureOnTouch) icon appears on the taskbar as follows.



If the taskbar icon appears as , the scanner is not properly connected to the computer. Check the status of the power switch and USB cable.

Turning Off the Power

When you press the power button for a short time, the touch panel and the power button turn off.

They turn on again when you either press the power button again, touch the touch panel, or place a document in the document feed tray. When you press and hold the power button two seconds or longer, the scanner turns off.

 **IMPORTANT**

- When turning on the scanner after it turns off, wait at least 10 seconds before turning it back on.
- If you will not be using the scanner for an extended period, turn off the power and disconnect the power cord from the AC outlet for safety.

 **Hint**

The scanner's auto power off setting is enabled by default, and the scanner will turn off automatically if it is not operated for 4 hours. For details on how to disable this setting, [see "Operating the Settings Menu" on p. 35.](#)

Important Safety Instructions

To ensure the safe operation of this scanner, be sure to read the safety warnings and precautions described below.

Installation Location

The performance of this scanner is affected by the environment in which it is installed. Make sure that the location where the scanner is installed meets the following environmental requirements.

- Provide adequate space around the scanner for operation, maintenance, and ventilation.

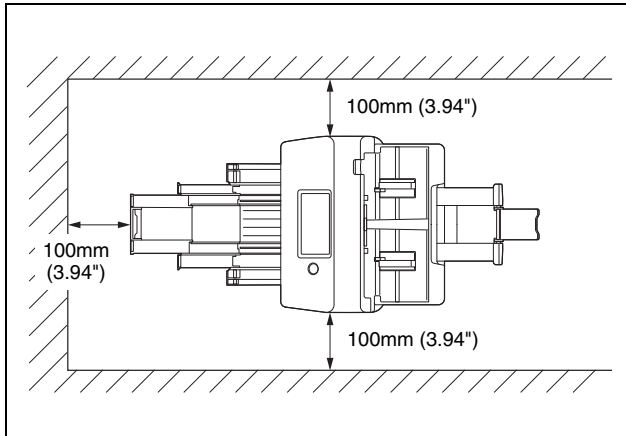

- Provide adequate space in front of the scanner for documents output after being scanned.
- Avoid installing the machine in direct sunlight. If this is unavoidable, use curtains to shade the scanner.
- Avoid locations where a considerable amount of dust accumulates as dust may adversely affect the inside of the scanner.
- Avoid warm or humid locations, such as in the vicinity of a water faucet, water heater, or humidifier. Avoid locations where ammonia gas is emitted. Avoid locations near volatile or flammable materials, such as alcohol or paint thinner.
- Avoid locations that are subject to vibration.

- Avoid exposing the scanner to rapid changes in temperature. If the room in which the scanner is installed is cold but rapidly heated, water droplets (condensation) may form inside the scanner. This may result in a noticeable degradation in scanning quality. The following conditions are recommended for optimal scanning quality:
Room temperature: 10 °C to 32.5 °C (50 °F to 90.5 °F)
Humidity: 20% to 80% RH
- Avoid installing the scanner near equipment that generates a magnetic field (e.g. speakers, televisions, or radios.)
- Do not block the ventilation holes. Doing so could cause the scanner to overheat, creating a fire hazard.

AC Adapter

- Connect only to a power outlet of the rated voltage and power supply frequency (120 V, 60 Hz or 220-240 V, 50/60 Hz depending on your region).
- Do not connect other electrical equipment to the same power outlet to which the scanner is connected. Also, when using an extension cord, make sure that the extension cord is rated for the current requirements of the scanner.
- Never try to take the AC adapter apart or modify it in any way, as this is dangerous.
- The power cord may become damaged if it is often stepped on or if heavy objects are placed on it.
- Do not use the power cord while it is coiled.
- Do not pull directly on the power cord. When disconnecting the power cord, grasp the plug and remove it from the outlet.
- Keep the area around the power cord clear of objects so that the power cord can be disconnected easily in an emergency.
- Do not use an AC adapter other than the one provided with the scanner. Do not use the AC adapter provided with the scanner with other products.
- If you have any questions regarding the power supply, contact your local authorized Canon dealer or service representative for further information.

Moving the Scanner

- When moving the scanner, always hold it with both hands to avoid dropping it.
- Make sure to disconnect the interface cable and AC adapter before moving the scanner. If the scanner is transported with these items connected, the plugs and connectors may be damaged.

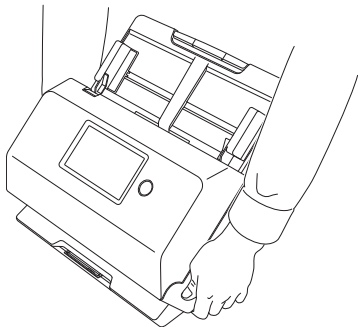

Handling

WARNING

Note the following precautions whenever using the scanner. Failure to do so may result in a fire or electric shock.

- Never use alcohol, benzene, paint thinner, aerosol sprays, or any other highly flammable substance near the scanner.
- Do not cut, damage, or modify the power cord. Do not place heavy objects on the power cord, and do not pull or excessively bend the power cord.
- Never connect the power cord when your hands are wet.
- Do not connect the scanner to a multi plug power strip.
- Do not knot or coil the power cord as this may result in a fire or electric shock. When connecting the power cord, make sure that the power plug is securely and completely inserted into the power outlet.

- The supplied power cord set is intended for use with this scanner only. Do not use it with other electronic equipment. In addition, do not use power cord sets other than the one supplied with the scanner. Doing so may result in fire or electric shock.
- Do not take the scanner apart or modify it.
- Never try to take the AC adapter apart or modify it in any way, as this is dangerous.
- Do not use flammable spray near the scanner.
- When cleaning the scanner, turn OFF the power and disconnect the power cord from the power supply.
- Clean the scanner using a slightly dampened cloth which has been well wrung out. Never use alcohol, benzene, paint thinner, or any other flammable substances.
- If the scanner makes strange noises, or gives off smoke, heat, or strange odors, or the scanner does not function or other abnormalities occur when you use the machine, immediately turn OFF the power, and disconnect the power plug from the power outlet. Then, contact your local authorized Canon dealer or service representative to have the unit serviced.
- Do not drop the scanner, or subject it to impact or strong shock. Should the scanner ever become damaged, immediately turn OFF the power, and disconnect the power plug from the power outlet. Then, contact your local authorized Canon dealer or service representative to have the unit serviced.
- Before moving the scanner, be sure to turn OFF the power, and disconnect the power plug from the power outlet

CAUTION

- Do not install the scanner on a surface that is unstable or tilted, or in an area subject to excessive vibrations, as this may cause the scanner to fall, resulting in personal injury or damage to the scanner.
- Never place small metal objects such as staples, paper clips, or jewelry on the scanner. These items may fall into the scanner, and cause a fire or electric shock. Should such objects ever fall inside the scanner, immediately turn OFF the power, and disconnect the power plug from the power outlet. Then, contact your local authorized Canon dealer or service representative to have the unit serviced.
- Do not install the scanner in a humid or dusty location. Doing so might cause a fire or electric shock.

-
- Do not place objects on top of the scanner. Such objects may tip or fall over, resulting in personal injury.
 - Connect only to a power outlet of the rated voltage and power supply frequency (120 V, 60 Hz or 220-240 V, 50/60 Hz depending on your region). Doing so might cause a fire or electric shock.
 - When unplugging the power cord, grasp it firmly by its plug. Do not pull directly on the power cord, as this may damage or expose the cord's internal wiring, resulting in a fire or electric shock.
 - Leave sufficient space around the power plug so that it can be unplugged easily. If objects are placed around the power plug, you will be unable to unplug it in an emergency.
 - Do not allow water or flammable substances (alcohol, paint thinner, benzene, etc.) to spill into the scanner, as this may result in a fire or electric shock. Doing so might cause a fire or electric shock.
 - Turn OFF the power for safety when not using the scanner for a long period of time, such as overnight. Also, turn OFF the power and disconnect the power cord from the power outlet for safety when the machine will not be used for an extended period of time, such as during consecutive holidays.
 - Do not wear loose clothing or jewelry that may get caught in the scanner while you are using it, as this may result in personal injury. Be extra careful of neckties and long hair. If anything becomes caught in the scanner, immediately disconnect the power cord to stop the scanner.
 - Be careful when loading paper into the scanner and when removing jammed paper, as it is possible to cut your hand on the edge of a sheet of paper.

Disposal

When disposing of this scanner, be sure to follow all local ordinances and laws or consult with the retailer who sold you the scanner.

When sending the scanner for repairs

When a request is made for repairs, the scanner needs to be sent to the specified address. When sending the scanner, use the packing box in which it came. Firmly secure the scanner with packaging material when you place it in the packing box.

About wireless communication functions

This device incorporates wireless communication functions. The radio waves used for wireless communication functions can affect medical and other devices, which could cause serious accidents. Do not use the wireless communication functions in the following conditions.

- Do not use the wireless communication functions if you have a heart pacemaker. The radio waves may affect pacemaker operation.
- Do not use the wireless communication functions near persons using medical devices like heart pacemakers. The radio waves may affect pacemaker and similar devices' operation. Contact the appropriate medical institution before use.
- Do not use the wireless communication functions inside medical institutions such as hospitals, or near electronic medical equipment. The radio waves may affect electronic medical equipment. Consult with any medical institution before using it inside their facilities.
- Do not use the wireless communication functions inside aircraft. The radio waves may affect precision equipment in the aircraft, and could cause a malfunction resulting in serious accident.
- Do not use the wireless communication functions near automatically controlled devices such as fire alarms. The radio waves may affect such devices and could cause a malfunction resulting in accident.
- When using the wireless communication functions, keep this device at least 20 cm from your body.

About the radio waves

This device operates in the 2.4 GHz frequency band (2.400 to 2.4835 GHz). Other users of these frequencies include products such as microwave ovens, scientific and medical devices, similar Wi-Fi stations, wireless intercom radio equipment for mobile device identification used in industrial production lines (requiring licensing), specific low-power radio stations that do not require licenses, amateur radio stations and others (all afterwards called "other stations"). When using, be aware of the following.

1. Before using this device, check whether other stations are operating.

-
2. If radio frequency interference occurs between this device and other stations, immediately relocate the device or stop using it (stop transmitting).
After stopping, consult with your retailer or with our sales staff regarding measures to avoid interference (e.g., partitioned installation).
 3. Otherwise, if troubles occur from radio frequency interference by this device to other stations, consult with your retailer or our sales staff.

Regional availability and limitations

Several versions of this product are provided for compliance with the various international wireless laws. The regions of availability for each version are as follows. Please note that each version may be used only in its applicable country/region. For regions not included in the following list, contact customer service.

Version Name	Product Code	Applicable Country/Region	Wireless LAN Standard	Corresponding Channel	Maximum Wireless Output
R50 120V	4823C001	USA, Canada	IEEE 802.11b/g/n	Channels 1 to 11 (2.412 to 2.462 GHz)	EIRP 11.48 dBm

Features of the Scanner

The main features of the scanner are described below.

Scanner Features

- **Touch Panel**

The scanner is equipped with a touch panel, which makes intuitive operations possible.

- **Wide variety of Connection Modes**

Connections by USB or wireless LAN are available to support your operating environment. Supported USB formats include USB 3.2 Gen 1x1/USB 2.0.

- **Compact Design**

The scanner has a compact size of 291 mm (11.5") (W) × 600 mm (23.7") (D) × 378 mm (14.9") (H).

- **Full Auto Mode**

A Full Auto Mode is provided in CaptureOnTouch and the scanner driver to allow scanning under automatically determined conditions. Scanning conditions such as the color mode and page size are set automatically based on the document being scanned.

- **Auto Resolution Detection**

When enabled in the CaptureOnTouch or scanner driver settings, this function detects the content of documents and determines the scanning resolution automatically.

- **Card Scan**

You can scan business or ID cards.

- **Registering Scan Settings to Main Unit**

Often used settings for scanning and transmitting data can be registered to the scanner.

- **Variety of Scanning Modes**

The scanner is equipped with the following scanning modes. Black and White, Error Diffusion, Advanced Text Enhancement, Advanced Text Enhancement II, Active Threshold, Grayscale, and Color

* Advanced Text Enhancement and Active Threshold can clarify scanned text by processing background or foreground colors.

- **Fast Document Feeding**

Documents can be scanned at a speed of up to 40 pages per minute (A4 size, 200dpi).

- **Long Document Mode**

Depending on User Mode settings, it is possible to scan documents up to 3,000 mm long (118.1")

Detection Functions

- **Auto Color Detection**

Automatically detects whether scanned documents are color, grayscale, or black and white.

- **Paper Size Detection**

Detects the document page size before scanning.

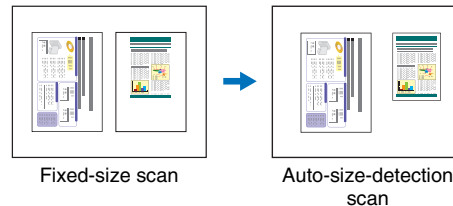

- **Text Enhancement Modes**

The scanner is equipped with an Advanced Text Enhancement mode to make it easier to read documents with dark backgrounds or documents with uneven backgrounds, and Advanced Text Enhancement II mode to make it easy to read text on documents that have an even background and on which both text and background are light colors, and Active Threshold mode to allow batch processing of various types of documents, such as those with light text or dirty manuscripts.

These modes may not work, depending on the type of document.

- **Ultrasonic Double Feed Detection**

The scanner stops feeding when the ultrasonic sensor detects that two or more document pages are feeding at the same time.

[“Detecting a document double feed”](#) (See p. 31)

- **Double feed detection by length**

The scanner stops feeding when a double feed is detected by comparing document page lengths. [“Detecting a document double feed”](#) (See p. 31)

* Based on the length of the first document page, the scanner detects a double feed when fed a different-length page.

- **Prescan**

At the start of scanning, this function prescans the first page and pauses so that you can adjust brightness and contrast before resuming scanning.

- **Text Orientation Detection**

The text orientation on each page is detected, and the scanned image is rotated in 90-degree increments as necessary for normalization.

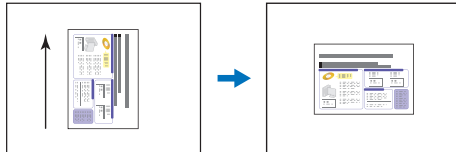

Orientation of document

Image rotated by text orientation detection

Image Processing

- **Prevent Bleed Through/Remove Background**

Prevents the background or original image on the reverse side of thin originals from appearing in scanned images.

- **Document orientation**

The text orientation on each fed page is detected, and the scanned image is rotated in 90-degree increments as necessary to match.

- **Deskew**

If a scanned image is detected to be skewed, the skewed image is straightened.

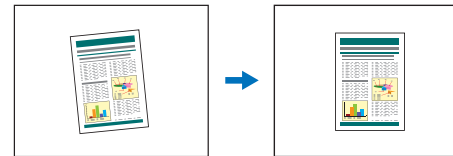

Skewed image

Deskewed image

- **Color Drop-out**

The scanner is equipped with a Color Drop-out function that enables you to specify a color for the scanner to omit from the scanned image during monochrome or grayscale scanning.



Multicolor original

Red dropped out

- **Skip Blank Page**

The scanner scans both sides of each page and skips saving images of pages detected to be blank.



Two-sided documents with blank page

Skipped blank page

- **MultiStream** **Windows**

With applications that support the scanner's MultiStream capability, three images with different scanning conditions are created from a single scan pass. However, this function is only available when using software that supports MultiStream.



Document to be scanned

Two types of images output

- **Thickening Text and Lines**

If text and lines in scanned images are very thin, this function corrects for their thickness while scanning.

- **Background smoothing**

Processes scanned images to smooth the background. It can be used when [Detect automatically], [Grayscale], or [Color] is selected for [Color Mode] on the [Basic] tab sheet.

- **Patchcode Detection** **Windows**

Patchcode sheets can be inserted in the document stack to perform batch separation. "[More Advanced Scanning Methods \(Batch Separation\)](#)" (See p. 74)

Other requirements

- **Auto Start**

The scanner is equipped with an auto start function, which enables scanning to be automatically started when a document placed in the feeder is detected.

- **Sleep Mode**

The scanner is designed to save energy by automatically entering the sleep mode if 10 minutes elapse without scanning or another operation being performed.

Names and Functions of Parts

Front View (With the Document Eject Tray Closed)

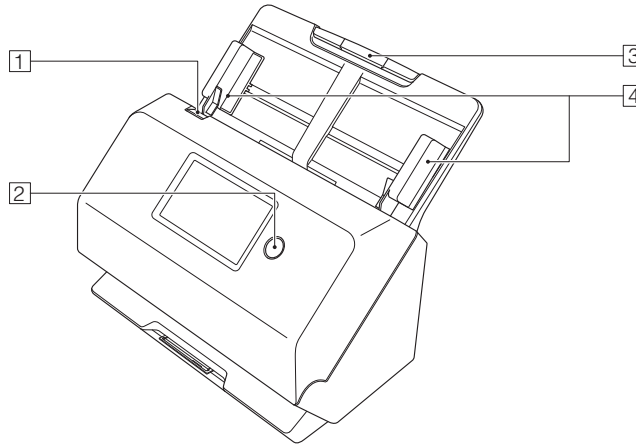

1 OPEN Lever

Pull this toward you to open the front unit.

2 Power button

Press this to turn on the scanner. When pressed, the power indicator is lit.

Press this button again to turn off the power.

The power button lights or flashes as follows depending on the scanner status.

3 Document Feed Tray

Place the document.

4 Document Guides

Align the document guides with both edges of the document to ensure that the document feeds straightly.

Power Button Indication	Description
Lit	Power is on
Flashing (slowly)	Sleep mode
Flashing (quickly)	An error (paper jam, front unit is open, double feed, etc.) has occurred

Front View (With the Document Eject Tray Open)

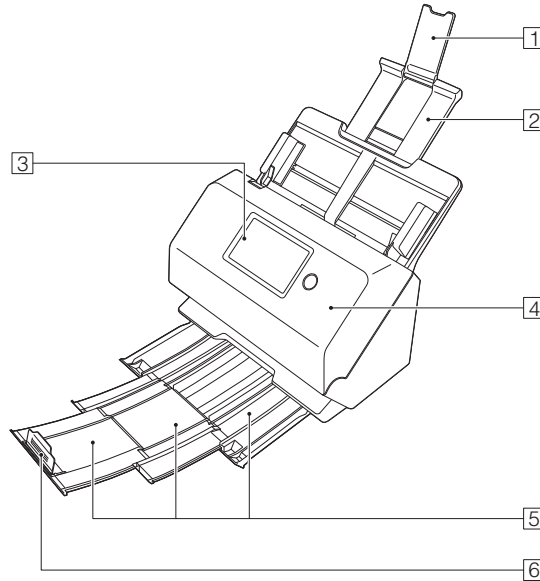

1 Feed Extension Support

Open this when placing long paper in the scanner.

2 Feed Support

Pull this out to support loaded documents.

3 Touch Panel

You can touch the screen to operate the scanner's various functions.

4 Front Unit

Open this when cleaning the inside of the scanner or replacing rollers.

5 Document Eject Tray

Pull this out to scan documents. Scanned documents are output here.

When scanning multiple documents of varying sizes at one time, pulling out and lifting up this tray locks the angle of the tray, so the documents ejected onto the tray are aligned.

6 Document Eject Stopper

This prevents the document coming out of the document eject tray and aligns the leading edges of the ejected document. It can be moved to any position on the document eject tray to match the length of the document.

Back View

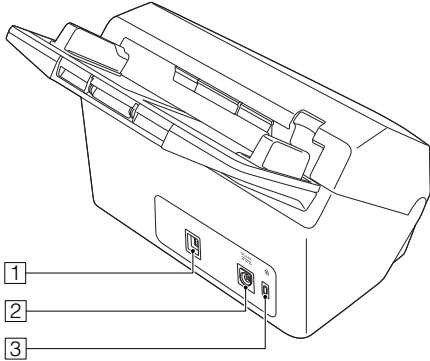

1 USB Connector

Connect the supplied USB cable to this connector.

2 Power Connector

Connect the supplied AC adapter to this connector.

3 Theft Prevention Hole (Security Slot)

Connect an anti-theft key chain or the like.

Touch Panel

The content that appears on the touch panel varies depending on the state of the scanner.

Refer to “[Operating the Settings Menus](#)” (See p. 35) for details and the operations in the various screens.

A typical example of a screen is shown below.

Home Screen

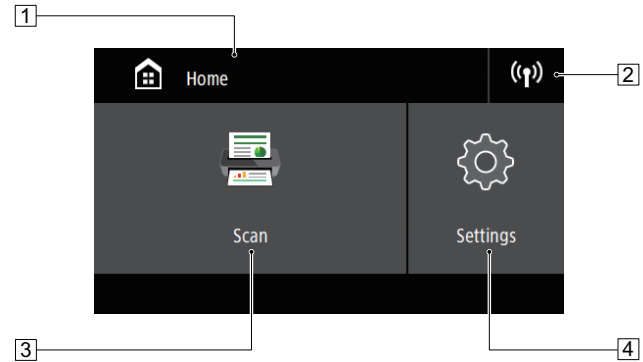

1 Title Area

Displays the title of the operating screen.

2 Switch Connections Button

Displays the switch connections screen.

The icon that is shown here changes as shown below depending on how the scanner and computer are connected.



When connected via USB



When connected via Wi-Fi

3 Scan Button

Use a job on the scanner to scan documents. (See p. 50)

4 Settings Button

Displays the settings menus screen. (See p. 35)

Job List Screen

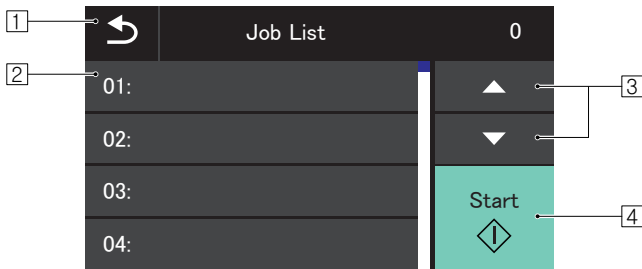

1 Back Button

Return to the previous screen.

2 List Area

Displays the menu items and job items that can be selected.

3 ▲▼ Button

Scrolls the list up and down.

4 Start Button

Starts scanning documents.

The following are other icons that appear depending on the state of the screen.



Updates the list.



Displays the home screen.

Input device PIN Screen

When the PIN function is enabled, entry of a PIN is required when the scanner is turned on. PIN function can be enabled or disabled using the Web menu. "PIN Setting" (See p. 85)

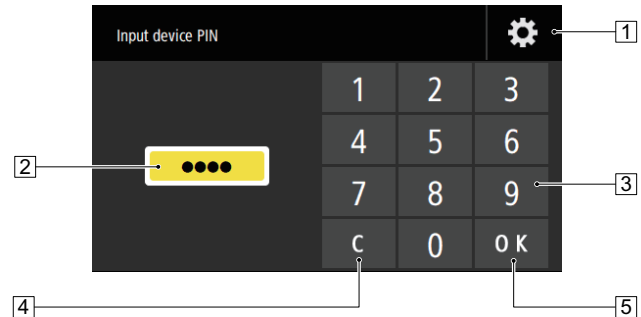

1 Admin User Login Screen Button

Displays the Admin User Login screen.

2 PIN

The entered PIN is displayed.

3 Number buttons

Enter numbers.

4 Clear Button

Deletes one numeral from the entered PIN.

5 OK Button

Executes PIN authentication.

Admin User Login screen

This may be displayed when the PIN function is enabled. PIN function can be enabled or disabled using the Web menu. ["PIN Setting"](#) (See [p. 85](#))

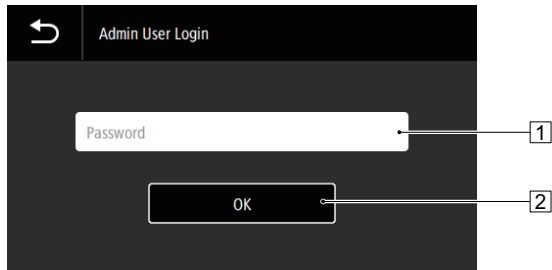

1 Password

Enter a password.

2 OK Button

Log in on the scanner as an administrator. The administrator password is the same as the one for Web menu. (See [p. 77](#))

Documents

The scanner can scan documents ranging in size from business cards to LTR/A4. The document sizes that this scanner can scan are shown below.

Plain Paper

Size

Width: 50.8 mm to 216 mm (2" to 8.5")

Length: 54 mm to 356 mm (2.1" to 14") (You can scan documents up to 3,000 mm (118.1") long by setting the scanner to the Long Document mode.)

Paper thickness

27 to 209 g/m² (7 to 56 lb bond) 0.04 mm to 0.25 mm (0.00157" to 0.00984")

Loading capacity

A4 size or smaller: 60 sheets (80g/m² (22 lb bond))

Larger than A4 size: 40 sheets (80g/m² (22 lb bond))

Make sure stacks do not exceed 6 mm in height for either of the above.

! IMPORTANT

The documents to be scanned must satisfy certain criteria. Read the following items carefully.

- When scanning multiple documents of different sizes, place the documents so that they cover the entire span of the feed rollers by aligning the centers and leading edges of the documents.

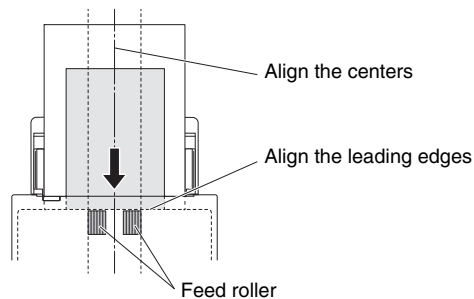

- It is recommended that documents exceeding 356 mm (14") size are fed one sheet at a time.
- Scanning documents before the ink is dry can cause problems with the scanner. Always make sure that the ink on a document is dry before scanning it.
- Scanning documents that are written in pencil or similar material may make the rollers and scanning glass dirty, which can lead to smudges on the scanned image and transfer the dirt to subsequent documents. Always clean the internal parts of the scanner after scanning such documents.
- When scanning a two-sided document that is printed on thin paper, the image on the opposite side of each page may show through. In this case, adjust the scanning intensity in the application software before scanning the document.
- Laminated documents may not be scanned correctly, depending on the document.
- Scanning the following types of documents can cause a paper jam or malfunction. To scan such a document, make a photocopy of the document and then scan the photocopy.



There are creases or fold lines.



There are curls.



There are tears.



There are clips or staples.



Carbon paper



The surface is coated.



Extremely thin document such as semi-transparent thin paper.



Documents with excessive paper dust particles.

Business Card

Size: 50 mm x 85 mm (2" x 3.35") or larger
Paper thickness: 380 g/m² (80 lb bond) 0.45 mm (0.0177") or smaller

IMPORTANT

If a stack of business cards cannot be fed properly, reduce the number of cards in the stack.

Card (plastic)

Size: 54 mm x 86 mm (2.12" x 3.37") (ISO standard)
Card thickness: 1.4 mm (0.055") or smaller
Orientation: Horizontal feeding only
Embossed cards can be scanned.
Loading capacity: 3 cards (non-embossed), 1 card (embossed)

CAUTION

- When scanning cards, place them to be fed horizontally. If you place cards to be fed vertically, they may not be ejected properly, and cards that get jammed may be damaged when you remove them.
- Embossed cards may not be able to be scanned correctly, depending on the type of embossment.
- When scanning cards, clear the [Detect by Ultrasonic] check box in the [Error Detection] tab on the scanner driver settings screen. (See p. 31)

How to Place Documents

Scanning multiple documents

Standard paper feeding should be used when scanning multiple documents of a standard size at one time. Standard paper feeding enables multiple documents to be fed while separating each page.

1 Pull out the document eject tray.

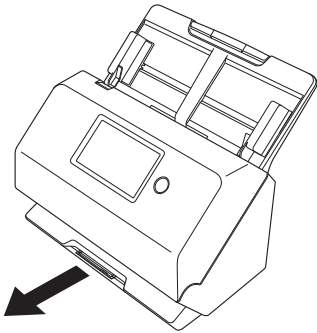

The document eject tray can be adjusted to 3 lengths. Pull out the document eject tray according to the length of the document. Also, erect the document eject stopper on the front edge if necessary.

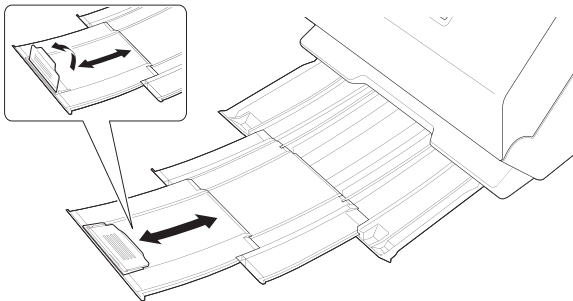

! IMPORTANT

Pull the document eject tray forward according to the various lengths.

2 Pull out the feed support.

Open the feed extension support when placing long documents.

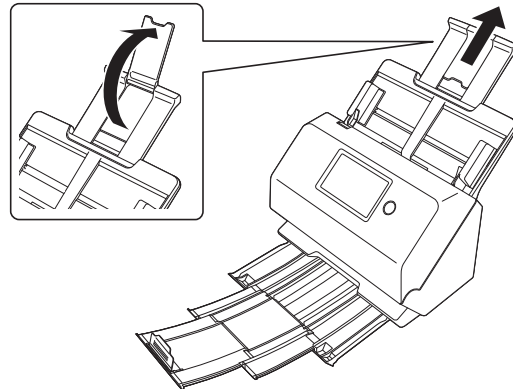

3 Adjust the document guides to fit the width of the document to be scanned.

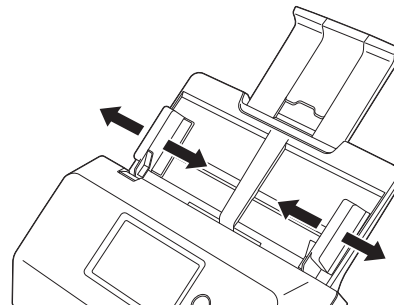

4 Place the document.

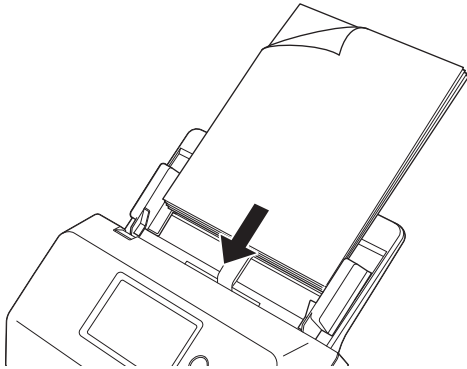

5 Align the document guides with both edges of the document.

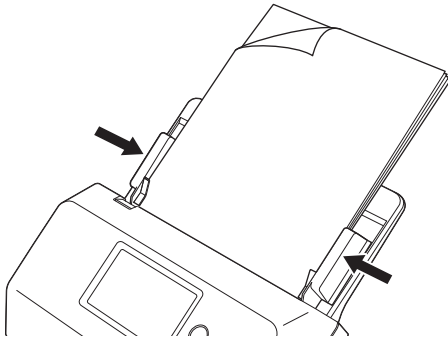

! IMPORTANT

- When placing documents into the feed tray, take care not to cut your hand on the edges of the paper.
- Before you place a document, check to make sure it does not contain paper clips, staples, or other small metal objects. These

items may cause a fire or electrical shock, damage the document, or cause a paper jam or scanner malfunction.

- Do not wear loose clothing or jewelry that may get caught in the scanner while you are using it, as this may result in personal injury. Be extra careful of neckties and long hair. If anything gets caught in the scanner, immediately turn OFF the power, and disconnect the power cord from the power outlet to stop scanning.
- Always smooth out any folds or curls in your documents before placing them into the feeder. If the leading edge of a document is curled, it may cause a paper jam.
- If feeding stops due to a system error or paper jam while the scanner is scanning, resolve the problem, make sure that the scanned image of the last page that was successfully fed has been stored, and then resume scanning the remaining document pages.
- After you finish scanning, close the document eject tray to prevent damage to the scanner while it is not being used.

Placing Cards

When scanning cards, place one card at a time horizontally.

1 Adjust the document guides to fit the width of the card to be scanned.

2 Place the card horizontally, with the reverse side facing you, and the top of the card facing down.

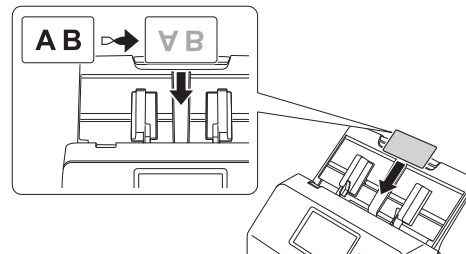

CAUTION

- Place the cards one at a time.
- When scanning cards, place them to be fed horizontally. If you place cards to be fed vertically, they may not be ejected properly, and cards that get jammed may be damaged when you remove them.

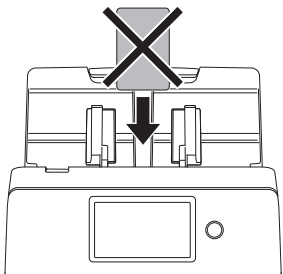

- When scanning cards, clear the [Detect by Ultrasonic] check box in the [Error Detection] tab on the scanner driver settings screen. (See p. 31)

Setting the Long Document Mode

The length of documents that can be scanned with the scanner is normally 356 mm (14"), but you can scan documents up to 3,000 mm (118.1") long by setting the scanner to the Long Document mode.

IMPORTANT

By selecting the Long Document mode and setting the [Page Size] on the scanner driver settings screen to Auto-detection, documents of up to 3,000 mm (118.1") in length can be scanned. Note the following when using the Long Document mode:

- When scanning in the Long Document mode, if the document is placed on the scanner in a skewed position, it may hit the edges of the feeding area and be damaged. Be careful to place the document so that it is not skewed.
- When scanning with the Long Document mode, paper jam detection may react slowly, resulting in damage to the document. Be careful to avoid paper jams.
- When scanning long documents, scan the documents one at a time.

- When scanning large-sized documents with the Long Document mode, scanning may be slower. Errors also occur due to memory shortage, and scanning may be disabled.

Windows

- 1 Open the scanner driver settings screen. (See p. 52)
- 2 In the [Basic] tab, click the [Setting] button of [Page Size]. [Page Size Settings] dialog box will open.



3 Click the [Long Document Mode] tab and specify the Long mode.

Depending on the length of the document, select [Long Document Mode (1000 mm)] or [Long Document Mode (3000 mm)].

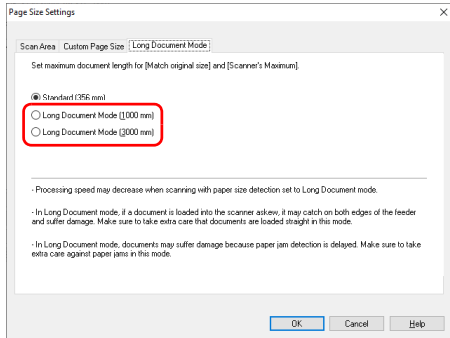

4 Click the [OK] button to close the settings screen.



Hint

When you set the Long mode, [(Long Document)] will be displayed in [Page Size] in the [Basic] tab.

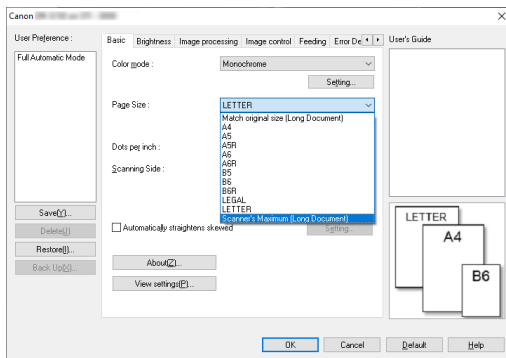

! IMPORTANT

When scanning documents with [Long Document Mode (3000 mm)] selected on the [Long Document Mode] tab, the image may not be scanned completely if 400 dpi or 600 dpi is selected, or if [Color] is selected for [Color mode] and [Duplex] is selected for [Scanning Side]. If this happens, select a lower dpi, or select [Monochrome] for [Color mode] or [Simplex] for [Scanning Side] and scan the document.

Mac

- 1 Open the scanner driver settings screen. (See p. 54)
- 2 Click  to display the [Scanner Information] dialog box. The [Scanner Information] dialog box appears.

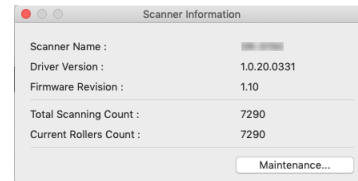

- 3 Click [Maintenance]. The [Maintenance] dialog box appears.

-
- 4** Select [Long Document mode (1,000 mm)] or [Long Document mode (3,000 mm)] depending on the length of the document.

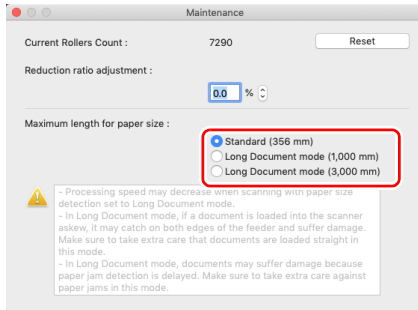

-
- 5** Click  to close the dialog box.

Detecting a document double feed

This scanner includes a function to detect document double feeds. By using this function, the scanner will automatically stop when it detects that multiple documents have been fed at the same time. You can also specify whether to save the scanned image after scanning has finished and continue scanning the document (double feed detection ignore function).

To use the double feed detection function, you must first open the scanner driver settings screen and enable double feed detection. It is also necessary to set [Rapid recovery system] to use the double feed detection ignore function.

Setting procedure

-
- 1** Sets the scanning conditions.

→ 

→ 

-
- 2** Place the document as described in the “[Scanning multiple documents](#)” procedure on p. 27.



-
- 1** Open the scanner driver settings screen. (See p. 52)

-
- 2** Click the [Error Detection] tab.

- 3** Select either the [Detect by Length] or the [Detect by Ultrasonic] check box (or both).

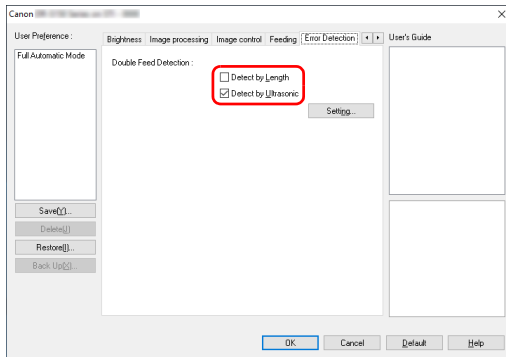

- 4** To use the double feed detection ignore function, open the [Others] tab and select the [Rapid recovery system] check box.

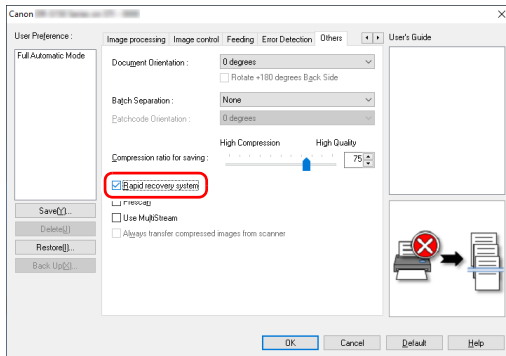

- 5** Click the [OK] button and close the settings screen.

Mac

- 1** Open the scanner driver settings screen. (See p. 54)
- 2** Select the [Double Feed Detection] check box, and then select any one of [Detect by Ultrasonic], [Detect by Length], and [Detect by Ultrasonic and Length].
- 3** Click the [More] button when the Double Feed Detection Ignore function is also used.
The scanner driver's Detail Settings screen opens.
- 4** Select the [Rapid recovery system] check box.

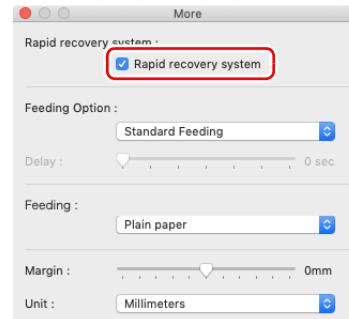

- 5** Click  to close the dialog box.

What to do when a double feed is detected

When not using the double feed detection ignore function

If a document double feed is detected during scanning, document feeding stops when the double fed documents are ejected. When this happens, the following error is displayed in the touch panel.

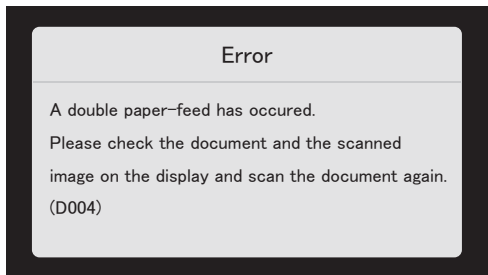

Also, a message screen is displayed to notify you that a double feed has been detected.

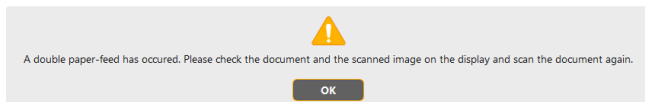

When this happens, stop the scanning in the application and then scan the documents again.

When using the double feed detection ignore function

If a document double feed is detected during scanning, document feeding stops when the double fed documents are ejected. The following message appears on the touch panel, and you can specify whether to continue scanning.

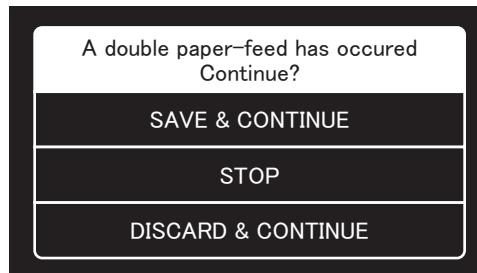

Also, the [Rapid Recovery System] screen appears to enable you to specify whether to continue scanning.

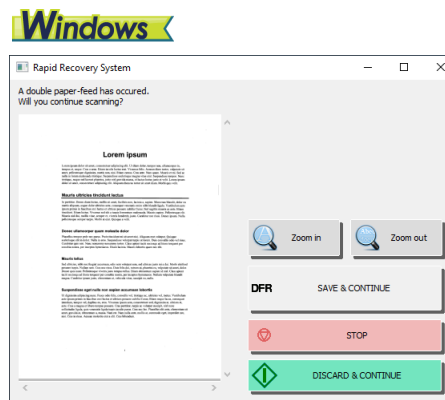

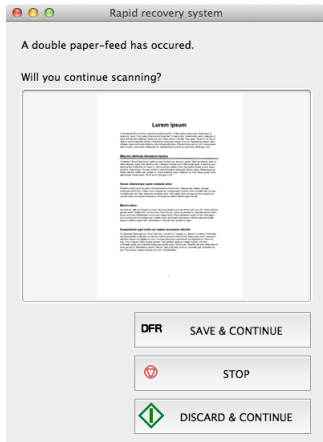

Buttons of [Rapid Recovery System] Screen	Description
[SAVE & CONTINUE]	Saves the preview image as a scanned image and scans the rest of the document.
[STOP]	Discards the preview image and stops scanning.
[DISCARD & CONTINUE]	Discards the preview image and continues scanning. Place the double fed document again before clicking this button.

Operating the Settings Menus

About the Settings Menus

The setting menus are functions that allows users to change some of the scanner's functions.

Procedure to operate the settings menu

Use the following procedure to operate the settings menus.

- 1 On the home screen of the touch panel, tap  (Settings) button.

The settings menu screen appears.

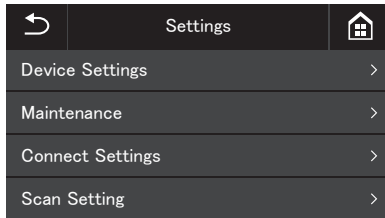

- 2 Tap the settings menu you want to change.

The menu hierarchy and menu items that can be selected are as follows.

First hierarchy	Second hierarchy	Third hierarchy	Fourth hierarchy	Fifth hierarchy
Device Settings	Brightness	-	-	-
	Language	-	-	-
	Power management	-	-	-
	Initialize	-	-	-

First hierarchy	Second hierarchy	Third hierarchy	Fourth hierarchy	Fifth hierarchy
Maintenance	Total Scanning Count	-	-	-
	Roller Feed Count	-	-	-
	Current Scan Count	-	-	-
	System Information	-	-	-
Connect Settings	Connection Switching	-	-	-
	Network Information	-	-	-
	IP Address Setting	Manual	Automatic	-
			IP Address	-
			Subnet Mask	-
	Network Settings	Wi-Fi Setting	Default Gateway	-
			Available Network	-
			WPS	-
			Manual	-
			Wireless Connection Tool	-

First hierarchy	Second hierarchy	Third hierarchy	Fourth hierarchy	Fifth hierarchy
Scan Setting	Detect Double Feed	-	-	-

3 Tap the various items to confirm and change settings.



Hint

When the ▲▼ buttons appear on a screen, you can tap them to scroll that screen.

Functions in the Settings Menus

The settings menus have the following functions.

Device Settings

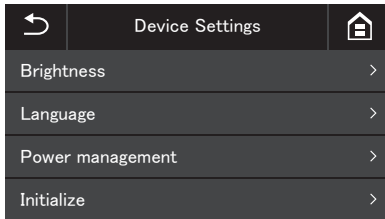

Select the following menu items to configure scanner operation.

Brightness

Tap the [-] and [+] buttons or the slider bar to adjust the brightness.

Language

Select the operation panel language from English, Japanese, French, Italian, German, Spanish, Dutch, Russian, Turkish, Chinese(Simplified), or Korean.

Power management

Sets the Auto Power Off Function.

When set to [Turn off automatically after 4 hours], the Auto Power Off Function automatically turns off the power supply after four hours without scanning or other operation.

Initialize

Initializes the various settings (Language/Connection mode/IP Address/Wi-Fi/Brightness/Power management/Jobs registered on scanner/SNMP).

Maintenance

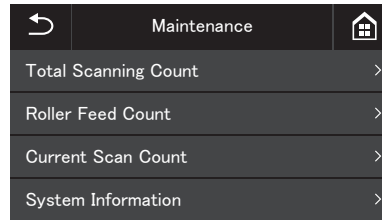

Select the following menu to do maintenance on the scanner.

Total Scanning Count

Shows the total number of scanned images recorded by the scanner.

Roller Feed Count

Shows the count of the number of sheets fed by the roller being replaced.

Tap [Reset] to reset the count.

Current Scan Count

Shows the number of sheets scanned since the scanner's power was turned on.

Tap [Reset] to reset the current number of sheets scanned.

System Information

Shows the following system information for the scanner.

- OS Version
- Firmware Version
- Kernel Version
- Scanner Name
- Serial Number
- Wireless MAC Address
- SSID

- Security Key
- "Scanner Name" shows what is set in the Web menu. (See p. 80)

Connect Settings

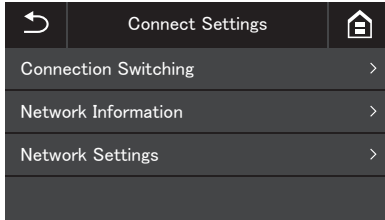

Set the following menu to do settings related to how the scanner and computer are connected.

Connection Switching

Change how the scanner and computer are connected.

Connect with USB cable: The scanner and computer are connected via USB cable.

Connect via Wi-Fi: The scanner and computer are connected via Wi-Fi.

By setting the connection mode, connection is possible only by that specific connection method. You cannot use multiple connection methods for the scanner and computer at the same time.

Network Information

Shows the following network information for the scanner.

- IP Address
- Subnet Mask
- Default Gateway
- SSID

[SSID] appears only when the connection mode is Wi-Fi mode. The SSID that is displayed is the SSID for the access point that is currently connected, or for an access point that was set in the past. The field is empty if one has never been set.

Network Settings

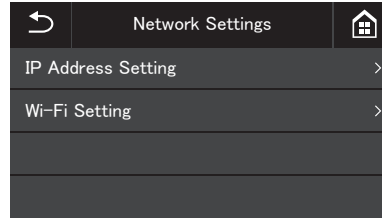

Select the following menu to set the network information.

IP Address Setting

The IP address can be set manually or automatically.

Automatic: Enables DHCP and acquires an IP address automatically.

Manual: Set the following network information manually.

- IP Address
- Subnet Mask
- Default Gateway

IMPORTANT

- If the entered IP address is "0.0.0.0", "255.255.255.255", "127.xxx.xxx.xxx", or "169.254.xxx.xxx", a warning screen is displayed and the entry is rejected.
- If the entered subnet mask is not a contiguous left-justified value, a warning screen is displayed and the entry is rejected.
- If the entered default gateway is "0.0.0.0", "255.255.255.255", "127.xxx.xxx.xxx", "169.254.xxx.xxx", a warning screen is displayed and the entry is rejected.

Hint

- After changing the settings in the [Manual] screen, tap the [OK] button. Pressing the  (Back) button cancels any changes to the settings.
- Network information can also be set in the Web menu. "Network Setting" (See p. 80)

Wi-Fi Setting

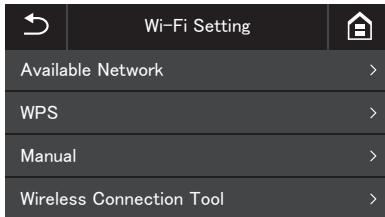

Select the following menu to do Wi-Fi settings.

Hint

Doing the Wi-Fi settings allows the connection mode to switch to Wi-Fi mode automatically.

Available Network

The networks that can be used are shown in the list. Tapping the name of the network to which you want to connect opens a security key setting screen. After you input the security key, the connection to the network starts. If connection is successful, the [Wi-Fi Setting] screen appears.

WPS

Follow the guidance on the panel, tap the [OK] button to start WPS connection. If connection is successful, the [Wi-Fi Setting] screen appears.

Manual

Manually type in the SSID and security key for the network to which you want to connect. Tap the [OK] button to start connecting to the access point. If connection is successful, the [Wi-Fi Setting] screen appears.

Wireless Connection Tool

Follow the guidance on the panel, tap the [OK] button to start connecting using the Wireless Connection Tool. If connection is successful, the [Wi-Fi Setting] screen appears.

Scan Setting

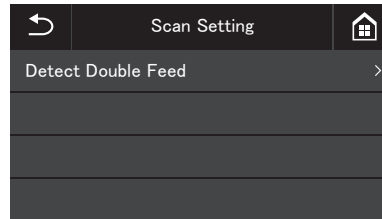

Select the following menu items to configure scan-related settings.

Detect Double Feed

Enable/disable Double Feed Detection.

Tap to switch between enabled and disabled.

There are two methods of double feed detection: comparing the length of documents, and detecting unevenness between documents by ultrasonic sensors, which can be set by the scanner driver.

This setting disables the Double Feed Detection function enabled in the scanner driver during the next scan only. It is enabled again once the scanning job has finished.

It cannot be enabled if it is disabled in the scanner driver.

[“When you want to detect multiple pages fed at the same time” \(See p. 64\)](#)

Scanning

With this device, you can scan documents by operating the touch panel or applications on a computer. CaptureOnTouch is a scanning application that enables you to scan a document with a simple operation merely by selecting the screen panel. Multiple scanning methods, which can be selected according to the purpose and application, are available.

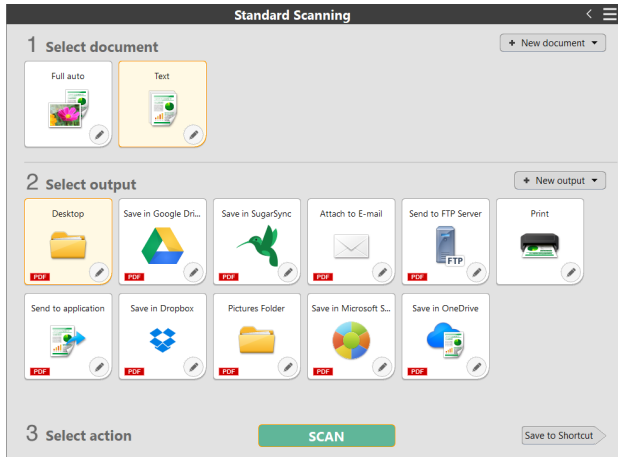

One Touch Scan

If you save a combination of frequently used document type and output method as a shortcut, you can have the document scanned and outputted by clicking one panel. This is useful when you use the same setting repeatedly.

Standard Scanning

Select the document type and the output method according to the purpose of the scan from the panels, and scan the document.

Assigning a shortcut to a Job No. and scanning from the scanner touch panel

If you assign a registered shortcut to a Job No., you can recall the job and scan the document from the scanner touch panel.

* The scanner to be used must be selected in CaptureOnTouch.

Scanning Using a Computer (CaptureOnTouch)

Starting and Exiting CaptureOnTouch

By default, CaptureOnTouch becomes resident in the system when you start your computer.

Windows

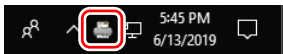

Double-click  in the taskbar to start CaptureOnTouch and display the main window.

Hint

You can also start CaptureOnTouch from the Start menu. Click [Start] - [CaptureOnTouch] - [CaptureOnTouch V4].

Mac



Click  (CaptureOnTouch icon) in the menu bar and then click [Launch CaptureOnTouch] from the menu which appears to start CaptureOnTouch and display the main window.

Exiting CaptureOnTouch

Windows

To close the CaptureOnTouch window, click at  the top of the window. This closes the window, but CaptureOnTouch will continue to reside in the system.

To quit the CaptureOnTouch application, click  in the taskbar, and select [Exit] from the menu.

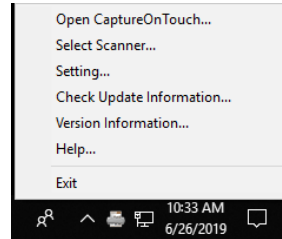

CaptureOnTouch becomes no longer resident in the system and the icon disappears from the taskbar.

Mac

To close the CaptureOnTouch window, click  at the top of the window. This closes the window, but CaptureOnTouch will continue to reside in the system.

Click  (CaptureOnTouch icon) in the menu bar, and select [Exit] from the menu.

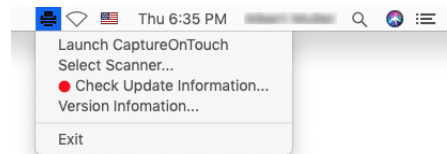

Restarting CaptureOnTouch

To use CaptureOnTouch after it has been made not resident in the system, use one of the following procedures to restart it. CaptureOnTouch will start and become resident in the system again.

Windows

- Click [Start] - [CaptureOnTouch] - [CaptureOnTouch V4].

Hint

In Windows 8.1, it is registered in the following location.

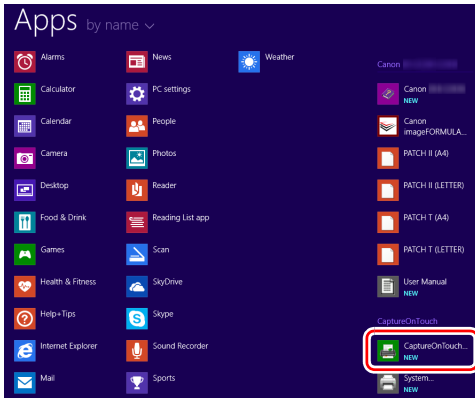

Mac

- Open [GO] - [Applications] folder from the Finder, and double-click [CaptureOnTouch].

Selecting a scanner

The following is an explanation of how to select a scanner using CaptureOnTouch.

Windows

Mac

Windows

- 1 Click the  (CaptureOnTouch Icon) on the taskbar.



- 2 Click [Select Scanner] on the menu.

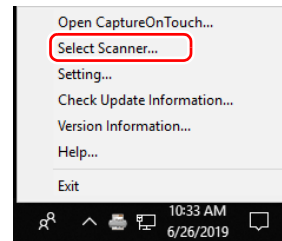

- 3 Select the scanner you are using and click [OK].

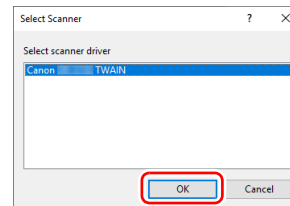

 **Hint**

If the scanner you are using does not appear, reinstall the scanner driver.

Mac

- 1 Click  (CaptureOnTouch Icon) in the menu bar and then click [Select Scanner] from the menu which appears.

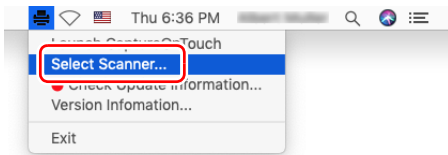

- 2 Select the scanner you are using and click [OK].

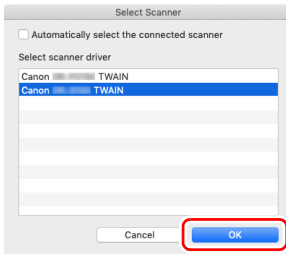

Screen Descriptions

There are two areas in the CaptureOnTouch main screen, [One Touch Scan] and [Standard Scanning].

Use the [>] [<] at the top right of the main window to move between sections.

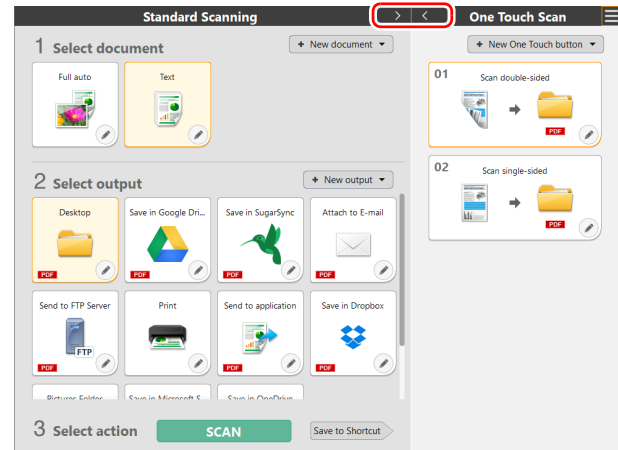

Various panels have been prepared according to the scan types and outputs in each section.

Click the [New document] button, and a [New document] panel will be added.

 **Hint**

Click  to open the Help. **Windows**

One Touch Scan

Operations;

Selecting the One Touch button -> Start scanning

You can register in advance combinations of frequently-used document selections and output methods as a “One Touch button”. Just click the One Touch button to implement the scan.

Hint

If you assign an One Touch button to a job number, you can execute One Touch Scan by selecting the job number from the scanner.

1 Place the document in the scanner. “Basic Operation” (See p. 25)

2 Click the One Touch button.

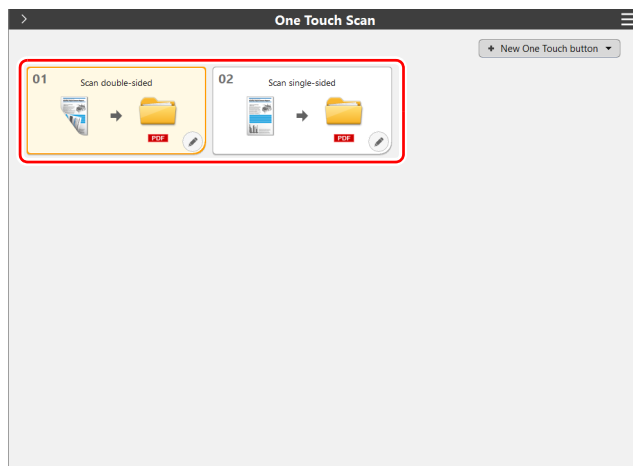

The document is scanned. While scanning is in progress, the number of pages scanned is displayed in addition to the scanner settings. When the scan is finished, the [Scanned image preview screen] opens.

CAUTION

- If you configure scanning conditions that consume a large amount of the computer's memory, scanning may stop because of insufficient memory. If an error message appears due to insufficient memory while scanning is in progress, stop scanning, change the scanning conditions, and then try scanning again.
- A multiple-page scan cannot be saved when it reaches the file size of 2 GB. Change the save settings if an error message is displayed.

Hint

If scanning continuously, set the next document, and click the [Continue scanning] button to start the document scan.

If [Continue scanning] is disabled in the One Touch button settings, the [Continue scanning] button will not be displayed.

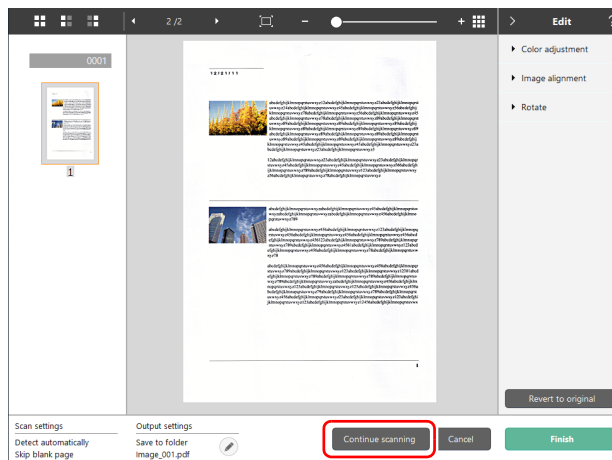

3 To check the scanned image, click the [Finish] button.

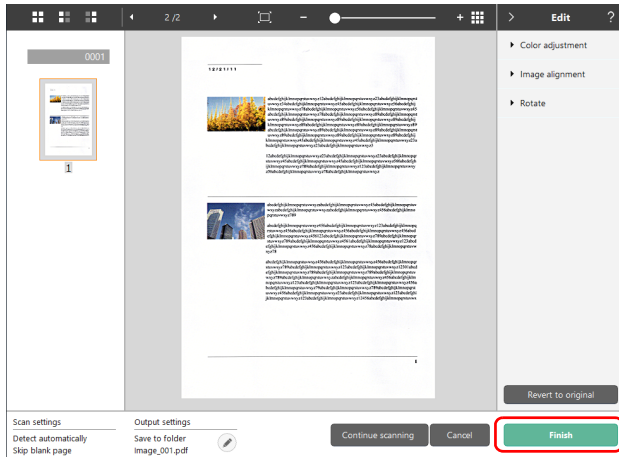

Hint

If [Edit after scanning] is disabled in the One Touch button settings, the edit window will not be displayed.

Click the  button to edit the output settings.

Click the [Cancel] button to discard the scanned image and return to the main window.

When the output has finished, a popup window will be displayed. If saving the scanned image, a link to open the save destination folder will be displayed.

This completes the One Touch scan.

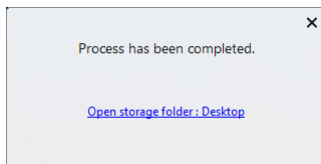

Hint

If you click [Open storage folder], the folder in which the saved scanned images were saved opens. Depending on the output settings, the [Open storage folder] link may not be displayed.

Registering and editing One Touch button

Multiple One Touch buttons can be allocated to CaptureOnTouch.

1 Either click the [New One Touch button] button in [One Touch Scan], or select the document scan and output in [Standard Scanning], and click the [Save to Shortcut] button.

An One Touch button will be created.

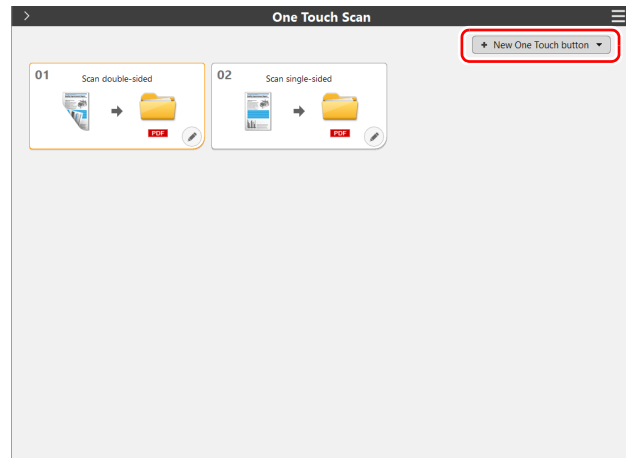

Hint

You can also create a new Destination panel by clicking  on the [New One Touch button] button, and in the menu that appears, selecting the type of One Touch button.

2 The One Touch button editing dialog box appears when you click the Edit button.

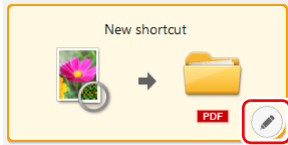

3 Click the [Document] tab to set the Select document settings.

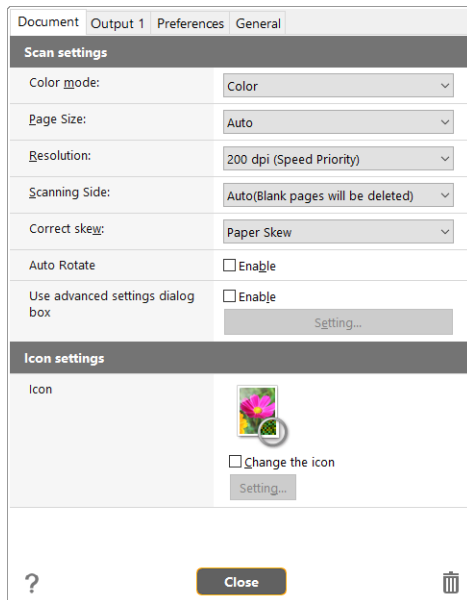

4 Click the [Output] tab to set the outputs.

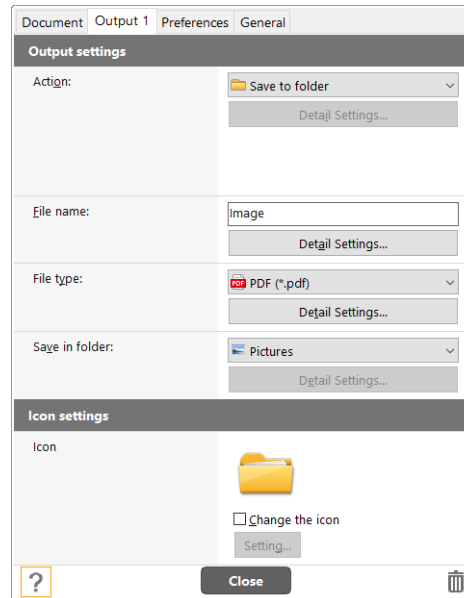

5 Click the [Preferences] tab to set the options.

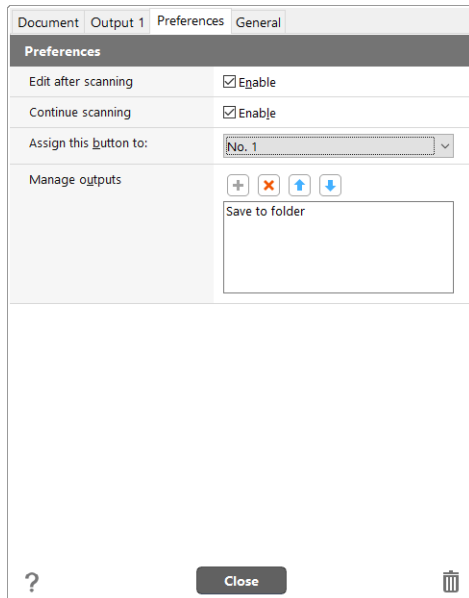

[Edit after scanning]

Check it on to enable modifying the scanned images in Scan Editing screen. When unchecked, the Edit window is not displayed in Scan Editing screen.

[Continue scanning]

Check it on to display [Continue scanning] button in the Scan Editing screen to enable continuing scanning.

[Assign this button to]

You can assign an One Touch button as a job. When an One Touch button is assigned as a job, an icon for the assigned job No. will be displayed in the One Touch button.

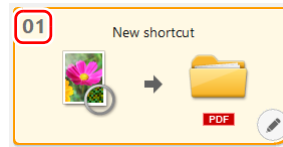

[Manage outputs]

You can add or delete the output, and also change the order of output.

6 Click the [General] tab to make other settings.

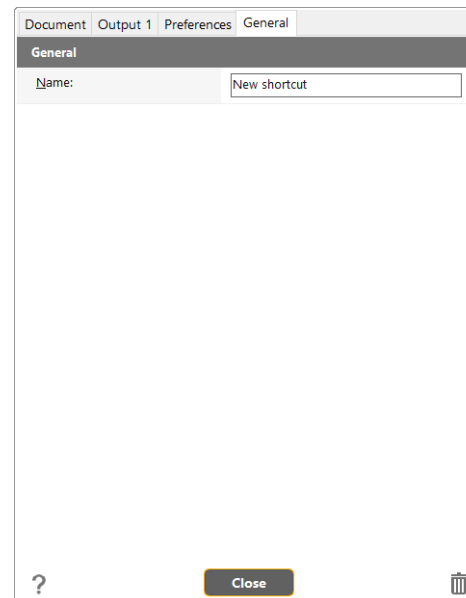

[Name]

Enter the One Touch button name.

Standard Scanning

Operations;

Selecting the Select document panel -> Selecting the Select output panel -> Start scanning

- 1 Place the document in the scanner.
- 2 Click the select document panel for the document to be scanned from [1 Select document].
The selected [Select document] panel will be displayed in orange.

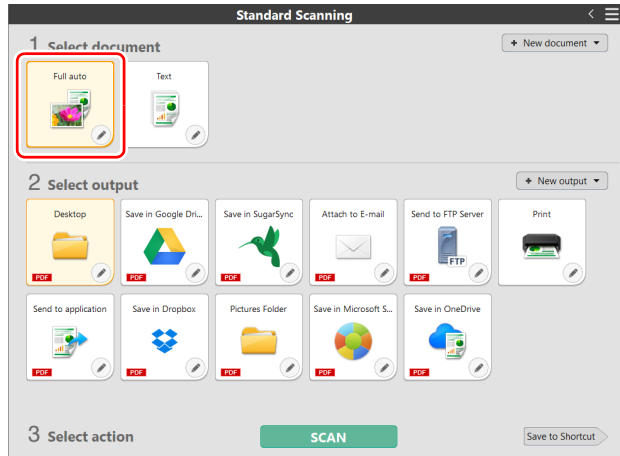

- 3 Click the output panel for the scan image application from [2 Select output].

The selected [Output] panel will be displayed in orange.

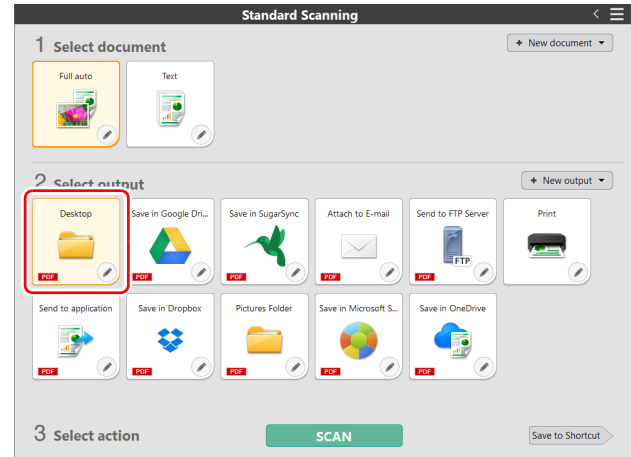

4 Click the [SCAN] button.

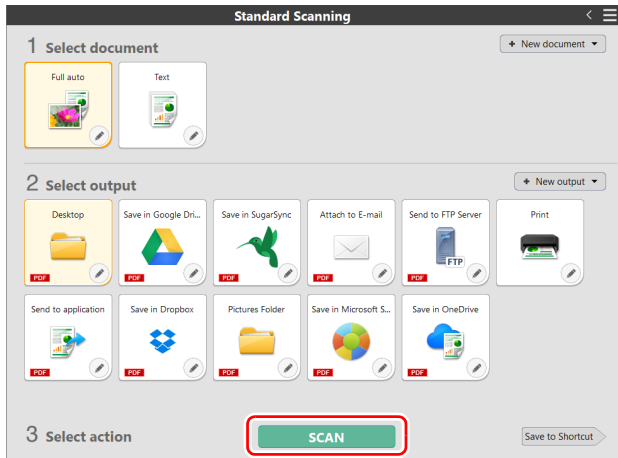

The document is scanned. While scanning is in progress, the number of pages scanned is displayed in addition to the scanner settings. When the scan is finished, the [Scanned image preview screen] opens.

Hint

If using the same document selection and output combination the next time, click the [Save to Shortcut] button. The Select document and Select output that you selected are added to One Touch button. A new button is added in the One Touch Scan view.

CAUTION

- If you configure scanning conditions that consume a large amount of the computer's memory, scanning may stop because of insufficient memory. If an error message appears due to insufficient memory while scanning is in progress, stop scanning, change the scanning conditions, and then try scanning again.
- A multiple-page scan cannot be saved when it reaches the file size of 2 GB. Change the save settings if an error message is displayed.

Hint

If scanning continuously, set the next document, and click the [Continue scanning] button to start the document scan.

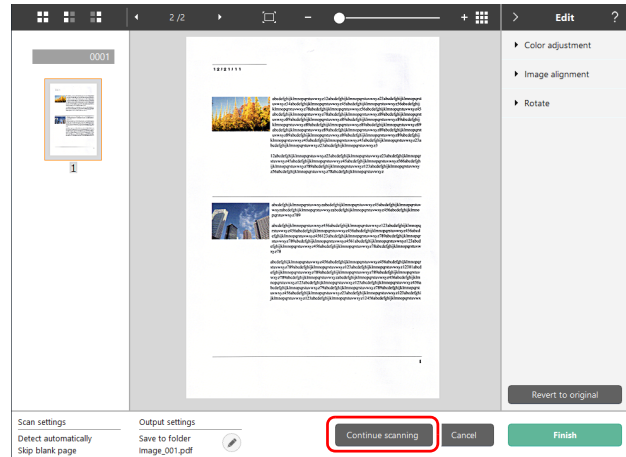

5 To check the scanned image, click the [Finish] button.

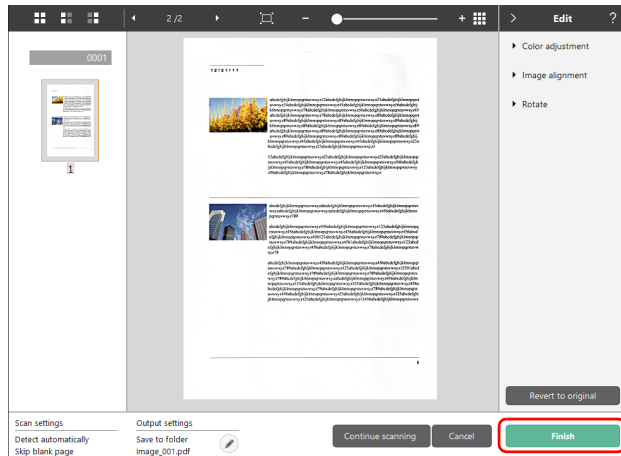

Click the  button to edit the output settings.

Click the [Cancel] button to discard the scanned image and return to the main window.

When the output has finished, a popup window will be displayed. If saving the scanned image, a link to open the save destination folder will be displayed.

This completes the Standard Scanning.

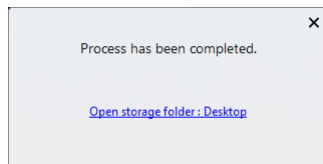

Hint

If you click [Open storage folder], the folder in which the saved scanned images were saved opens. Depending on the output settings, the [Open storage folder] link may not be displayed.

Scanning from the Scanner Touch Panel

If you set frequently-used scans to the One Touch buttons and assign them as jobs, you can select and run One Touch scans by operating the scanner touch panel.

Hint

- If the [Skip main screen when a scan is started from the scanner button] checkbox is enabled in the Settings, the main CaptureOnTouch window will not be displayed when a scan is started from the touch panel. Only dialog boxes and error messages during scanning, and completion popup windows are displayed.
- If the [Skip main screen when a scan is started from the scanner button] checkbox is enabled in the Settings, [Enable additional scan] and [Edit after scanning] will be disabled when scanning is started from the touch panel.

When connected via USB

1 Tap (Scan) on the touch panel home screen.

Jobs that are registered in CaptureOnTouch are displayed.

2 Tap the job you want to execute.

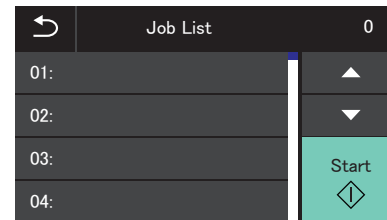

3 Tap (Start).

Scanning starts.

When connected via a network

1 Tap  (Scan) on the touch panel home screen.
The PC List screen is displayed.

2 Tap the computer you want to connect to.

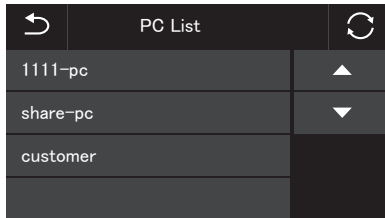

Jobs that are registered in CaptureOnTouch on the computer are displayed.

It is required that the computer and the scanner are on the same network and the scanner is selected in the [Select Scanner] dialog of CaptureOnTouch.



Hint

This screen is not displayed if there is only one computer on the network. Proceed to step 3.

3 Tap the job you want to execute.

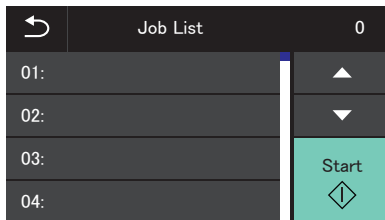

4 Tap  (Start).
Scanning starts.

Setting the Scanner Driver

When you load the driver for the first time, the selected scanner and a dialog for selecting the default paper size are displayed. **Windows** When you scan a document in a TWAIN compatible application, open the scanner driver and configure the scanning conditions and other settings.

This section describes the configuration and functions of the scanner driver.

Configuration and Functions of the Scanner Driver

→ **Windows**

→ **Mac**

Windows

The scanner driver consists of the following tabs.

Hint

For details on the setting screen, see the Help of the scanner driver. Click the [Help] button of the driver to display help related to the corresponding tab or dialog box.

[Basic] tab

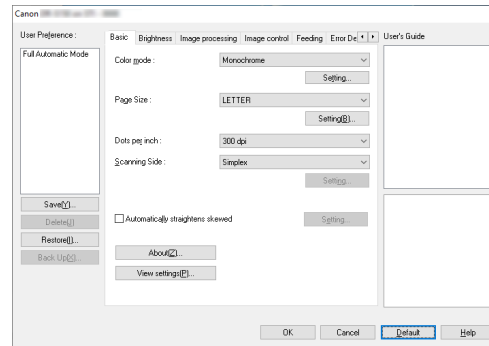

Configure basic scanning conditions such as the mode, page size, resolution, and scanning side.

Click [Setting] button of [Page Size], to set the scan area and the custom paper size registration and long mode.

[Brightness] tab

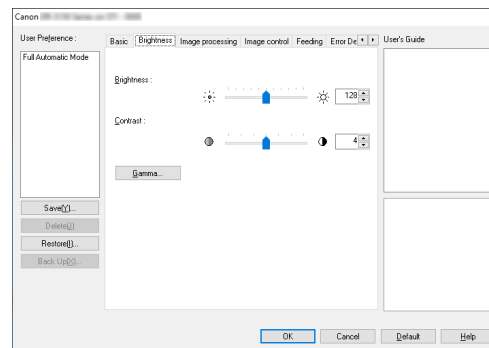

Adjust the brightness and contrast of scanned images.

In addition, you can also click [Gamma] and set the gamma correction value for scanned images.

[Image processing] tab

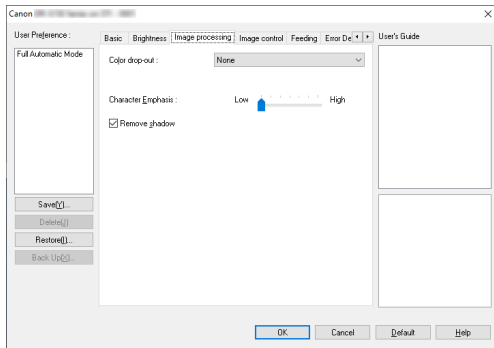

Set the processing method for scanned images.

[Feeding] tab

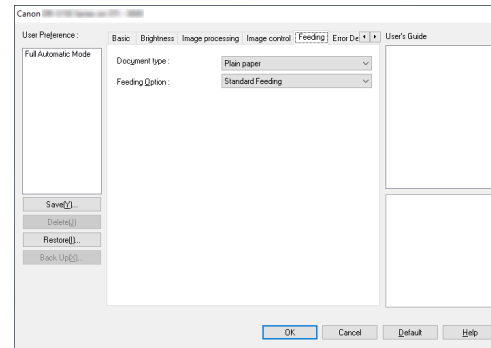

Specify scanner operations related to document feeding.

[Image control] tab

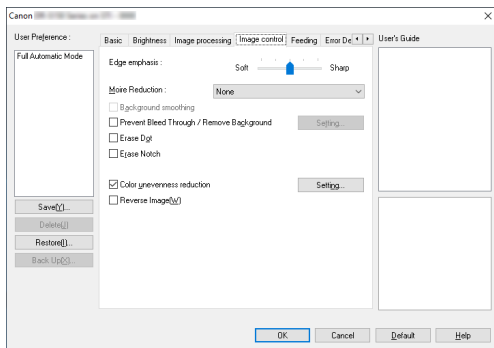

Set the image control method for the scanned image.

[Error Detection] tab

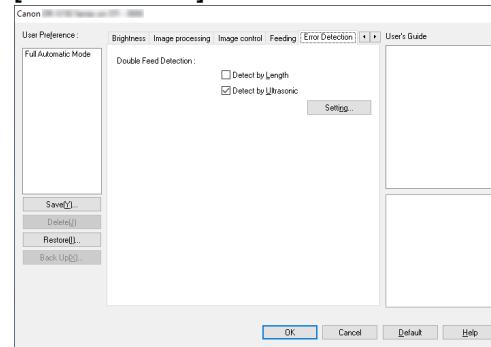

Set the items to be detected as errors during the scan.

[Others] tab

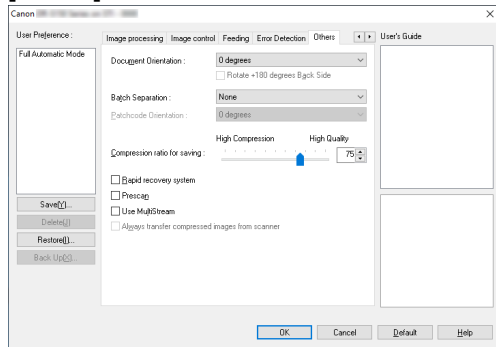

Configure special scan method and image processing settings.

User's Guide

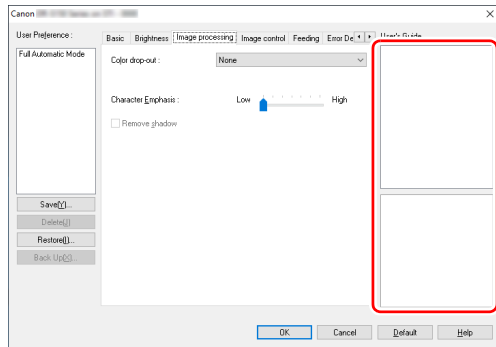

Informs you about the settings changed automatically by the driver. In addition, displays the image for which settings were currently made, in the illustrations.



When the scanner driver is opened from CaptureOnTouch, the following settings screen of the scanner driver appears.

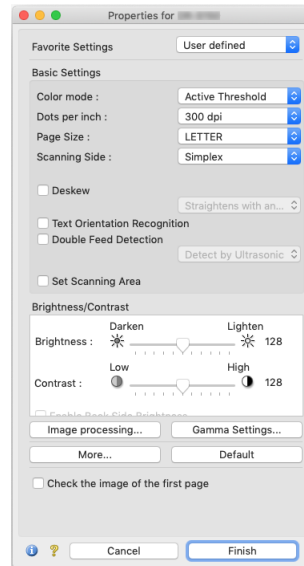



Hint

When the Advanced Settings screen is called from some applications, the Advanced Settings screen may have the Simple mode and Advanced mode.

Simple Mode

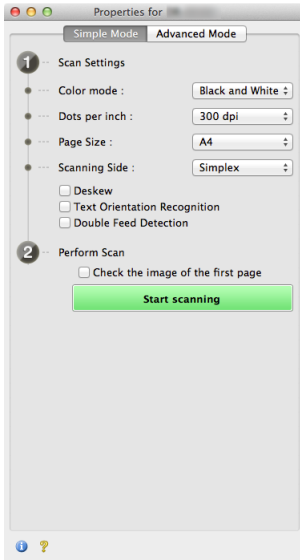

Advanced Mode

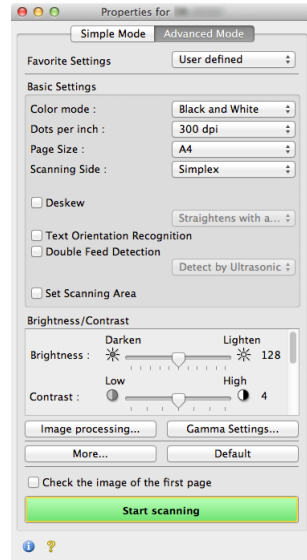

Setting Basic Scanning Conditions

This section provides an overview of the basic setting items that are the minimum requirements when configuring the scanner settings.



Confirming Basic Conditions for Scanning

When you scan a document, make sure you confirm the [Color mode], [Page Size], [Dots per inch], and [Scanning Side] basic conditions in the Basic settings dialog box.

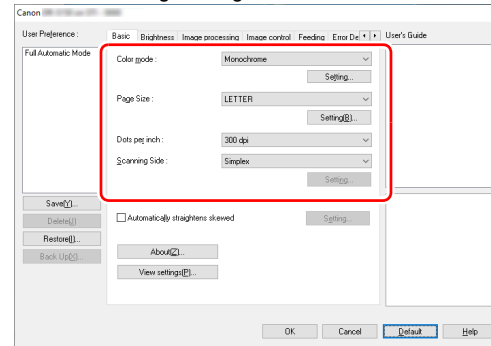

Color mode

Select the scanning mode.

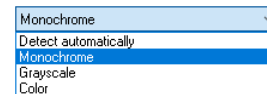

[Detect automatically] detects whether the document is in color, grayscale, or black and white. You can configure advanced settings related to the detection method by clicking [Setting]. For details, (See p. 63).

Page Size

Select the page size that matches the document to be scanned.

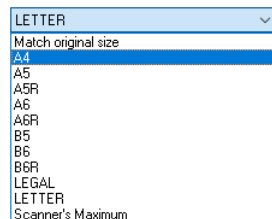

If [Match original size] is selected, the edges of the document are detected and images that match the size of the document are saved.

Dots per inch

Select the scanning resolution.

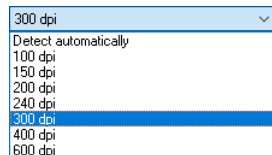

- Higher resolutions provide clearer images but result in larger file sizes and slower scanning.
- When [Detect automatically] is specified, the resolution is detected automatically from the content printed in the document.

Scanning Side

Select which of the sides of the document to scan.

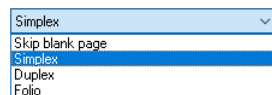

If the scanning side is set to [Skip blank page], the images of blank pages are deleted when images are saved.



Confirming Basic Conditions for Scanning

When you scan a document, make sure you confirm the [Color mode], [Dots per inch], [Page Size], and [Scanning Side] basic conditions in the settings screen of the scanner driver.

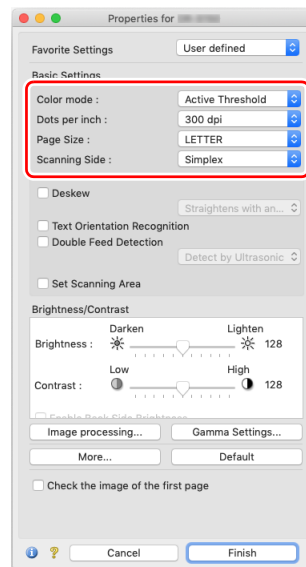

Color mode

Select the scanning mode.

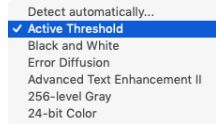

- [Active Threshold] is intended for batch processing various kinds of documents at once, such as those with thin (light) text or stains. For example, you can batch process documents such as photocopies at once. Brightness-related properties are automatically adjusted based on the text and background of the whole image, enabling consistent reproduction of light characters and removal of background stains.
- [Advanced Text Enhancement II] removes or processes the background color and background surrounding text to enhance the text for easy reading.
- [Detect automatically] detects whether a document is color, grayscale, or black and white based on its content. When this is selected, you can configure detailed settings for the detection method. Refer to the Help for details.

Dots per inch

Select the scanning resolution.

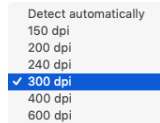

- Higher resolutions provide clearer images but result in larger file sizes and slower scanning.
- When [Detect automatically] is specified, the resolution is detected automatically from the content printed in the document.

Page Size

Select the page size that matches the document to be scanned.

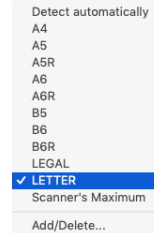

If [Detect automatically] is selected, the edges of the document are detected and images that match the size of the document are saved.

Scanning Side

Select which of the sides of the document to scan.

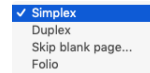

If the scanning side is set to [Skip blank page], the images of blank pages are deleted when images are saved.

Scanning Documents of Unregistered Page Sizes

Windows

You can register an unregistered paper of non-standard size with a name, as a custom paper size.

Click the [Setting] button of [Page Size] in the [Basic] tab, to display the [Page Size Settings] dialog box.

Register the paper of non-standard size in the [Custom Page Size] tab.

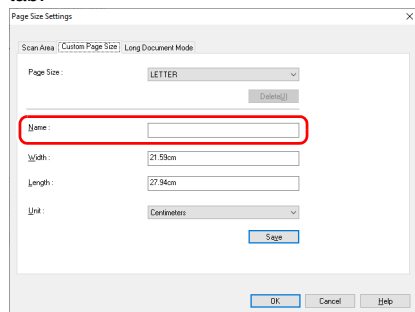

Specifying the Scan Area

Configure the following settings when you want to specify the area of the document to be scanned.

Specifying an area

Windows

To scan one area of a larger document, click [Setting] on [Page Size] in the [Basic] tab to display the [Page Size Settings] dialog box.

Designate which area of the document to scan in the [Scan Area] tab.

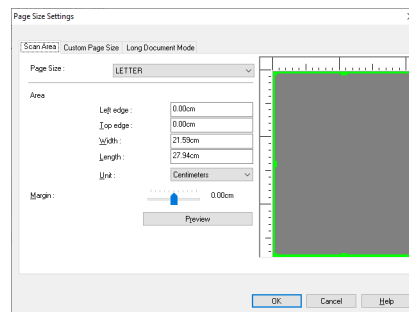

Mac

Configuring the following settings allows you to scan a document of an unregistered page size.

When scanning a document of a non-standard page size, select [Add/Delete] for [Page Size] to display the [Add/Delete Page Size] dialog box. Name and register the unregistered page size in [Page Size].

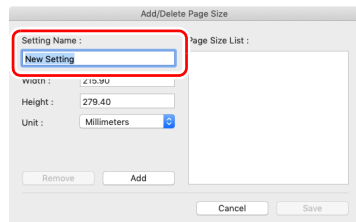

Mac

Select the [Set Scanning Area] check box and then specify the area of the document to be scanned.

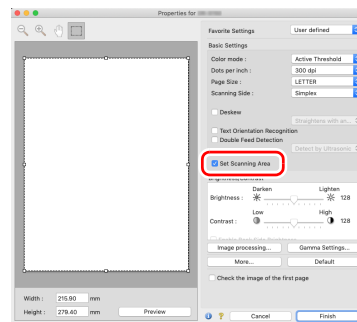

Also, if you scan the document when [Check the image of the first page] is selected, only one page of the document is scanned and the corresponding scanned image is displayed in the preview window.

Configuring Scanner Settings According to Purpose

Set the scanning conditions according to the scanning purpose.

When you want to delete the images of the blank pages in two-sided documents

Windows

Set the scanning side setting to [Skip blank page] on the [Basic] tab to delete the images of the blank pages in the document.

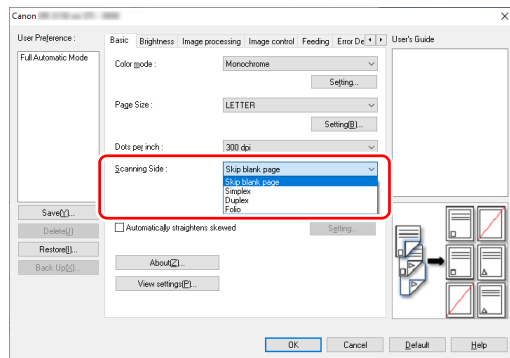

If [Skip Blank Page] is selected, the [Setting] button is enabled, and you can adjust the level for judging whether pages are blank.

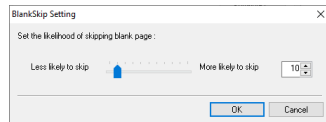

Mac

Set the scanning side setting to [Skip blank page] to delete the images of the blank pages in the document.

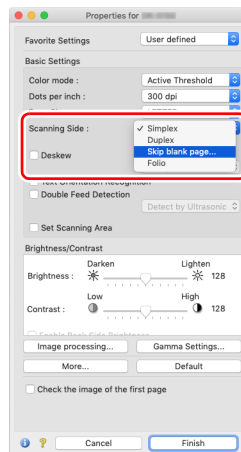

If [Skip blank page] is selected, you can adjust the level for judging whether pages are blank.

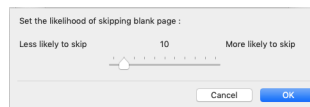

When you want to enhance contours in images

Windows

Adjust the edge emphasis setting on the [Image control] tab.

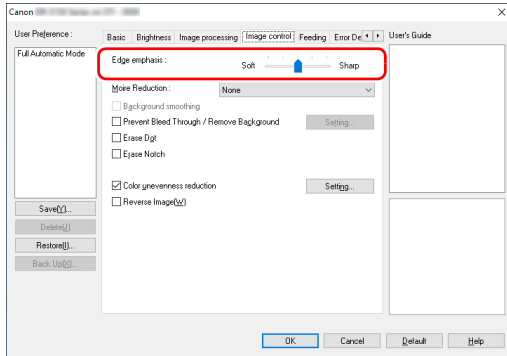

When you want to reduce the moire patterns that appear when color photos in magazines and other documents are scanned at low resolutions

Windows

Setting [Moire Reduction] on the [Image control] tab sheet allows you to reduce the moire patterns that are generated when color photos are scanned at low resolutions.

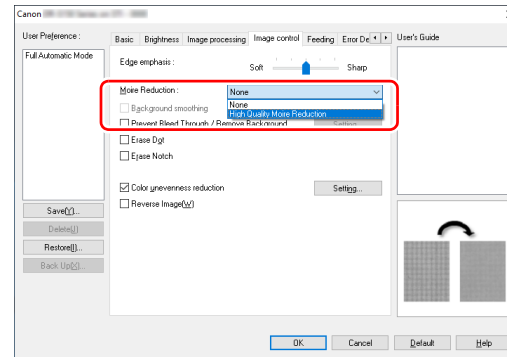

Mac

Click [Image processing] and adjust the edge emphasis settings in the dialog box which appears.

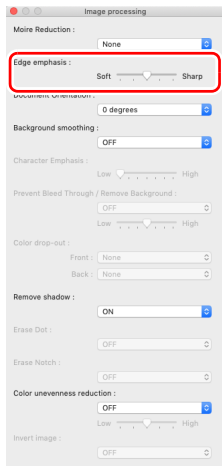

Mac

Click [Image processing], and then configure moire reduction settings in the dialog box that appears.

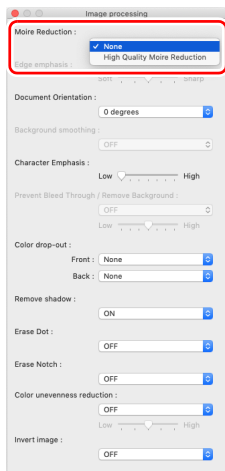

Hint

Moire reduction is enabled when the resolution is 300 dpi or less, and [High Quality Moire Reduction] is displayed when the resolution is 240 dpi or less.

When you want to reduce the color unevenness

Windows

Check the check box of [Color unevenness reduction] on the [Image control] tab to reduce the color unevenness.

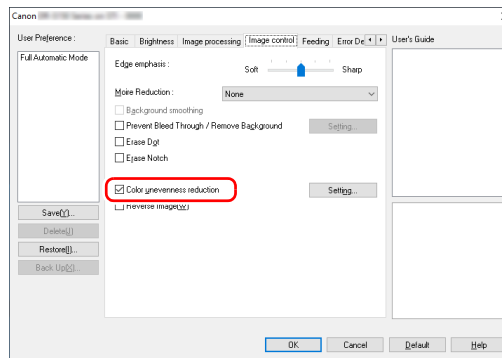

You can control the level of color unevenness by enabling the [Setting] button.

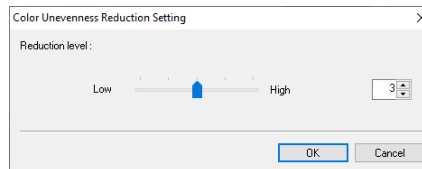

Mac

Click [Image processing], and then set [Color Unevenness reduction] to [ON] in the dialog box that appears. You can adjust the level of color Unevenness.

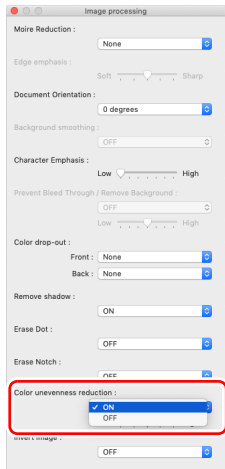

When you want to make lines and text in scanned images thicker or thinner

Windows

Drag the [Character Emphasis] slider in the [Image processing] tab to make lines and text in the scanned images thicker or thinner.

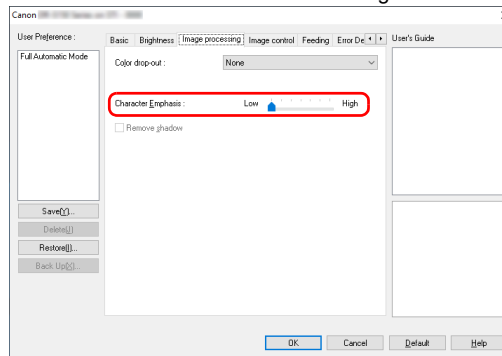

Mac

Click [Image processing], and in the dialog box that appears adjust letter and line thickness settings.

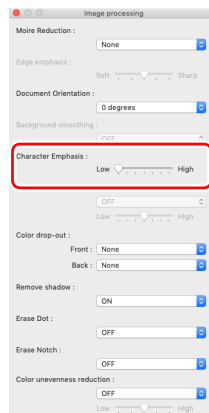

When you want to reverse black and white in scanned images

Windows

Select [Reverse Image] on the [Image control] tab sheet. This outputs scanned images with black and white reversed.

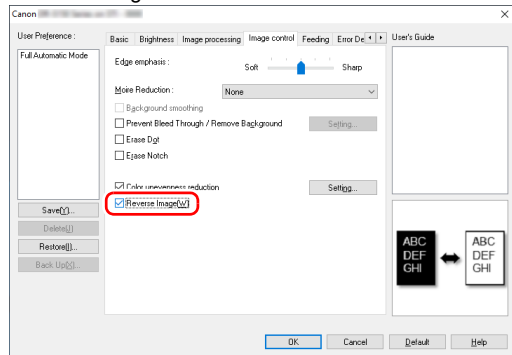

When you want to enhance text that is difficult to read because of factors such as the background of the scanned document

Windows

In the [Basic] tab, select [Monochrome], and then click the [Setting] button.

Remove the background behind the text or do some other process, so that the text is emphasized for better readability. You can select from the following functions.

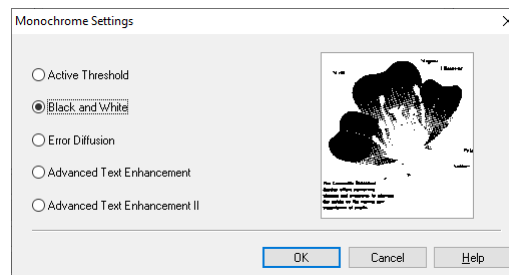

Mac

Click [Image processing], and then set [Invert Image] to [ON] in the dialog box that appears.

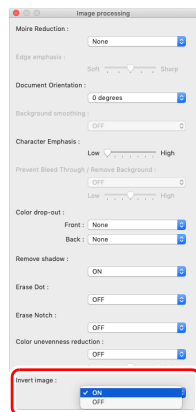

- [Active Threshold] is intended for batch processing various kinds of documents at once, such as those with thin (light) text or stains. For example, you can batch process documents such as photocopies at once. Brightness-related properties are automatically adjusted based on the text and background of the whole image, enabling consistent reproduction of light characters and removal of background stains.
- [Advanced Text Enhancement] is suitable for a document with a light background color or a document with a non-uniform background (such as a pattern). If the background is uniform, it is removed where it surrounds the text, and if the background is non-uniform, it is processed to enhance text readability.

- [Advanced Text Enhancement II] is suitable for scanning a document with a uniform background color and light text and background. If the background is non-uniform, such as a pattern, the background may not be able to be completely removed and the text may become difficult to read. If necessary, you can make the text in scanned images easier to read by adjusting the contrast on the [Brightness] tab.

Mac

Select [Active Threshold] or [Advanced Text Enhancement II] in the [Color mode] setting. The background behind the text is removed or processed so that the text is emphasized for better readability.

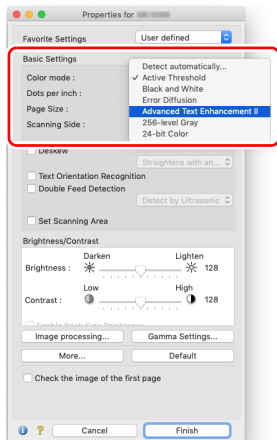

When you want to detect multiple pages fed at the same time

Windows

Select the [Double Feed Detection] check box on the [Error Detection] tab. You can enable either one or both of [Detect by Ultrasonic] and [Detect by Length].

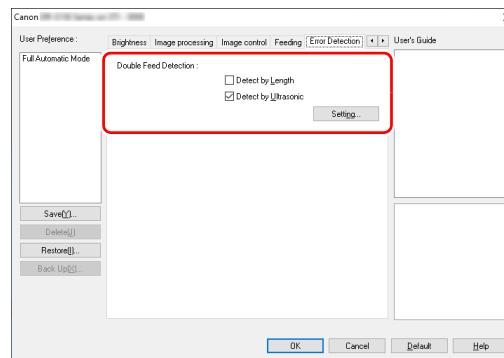

Mac

Select the [Double Feed Detection] check box.

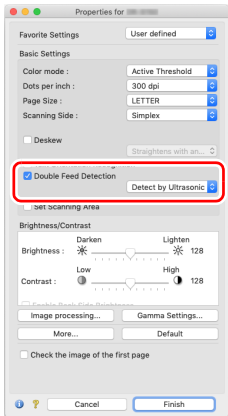

When you want to match the orientation of images to the text when scanning a mixture of pages with different text orientations

Windows

Select [Text orientation recognition] in [Document Orientation] on the [Others] tab. The text orientation on each page is detected, and the scanned image is rotated in 90-degree increments to correct the orientation.

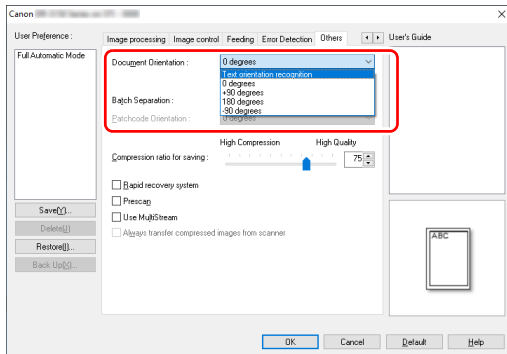

Mac

Select the [Text Orientation Recognition] check box. The text orientation on each page is detected, and the scanned image is rotated in 90-degree increments to correct the orientation.

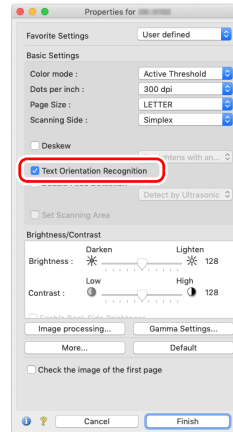

Hint

When the [Text Orientation Recognition] check box is selected, [Document Orientation] is unavailable.

When you want to rotate the images of a document placed horizontally to correct the orientation

Windows

Specify the rotation angle in [Document Orientation] on the [Others] tab.

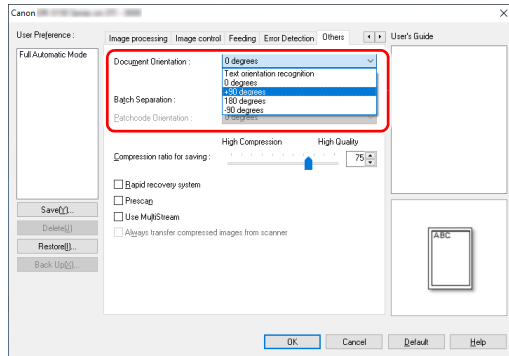

Mac

Click [Image processing] and specify the rotation angle in [Document Orientation] in the dialog box that appears.

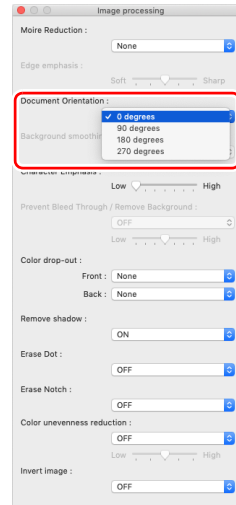

When you want to use batch separation for scanning

Windows

When you want to divide and scan a document, you can separate a batch at the timing with which each next document is placed and scanned. (Only enabled for applications that support batch separation.) In this case, set the scanner driver as follows.

- Set [Feeding Option] on the [Feeding] tab to [Panel-Feeding] or [Automatic Feeding].

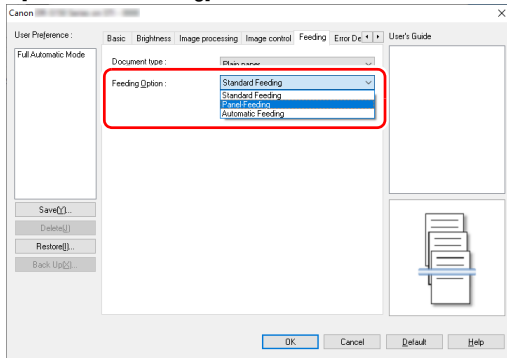

- Set [Batch Separation] on the [Others] tab to [Auto].

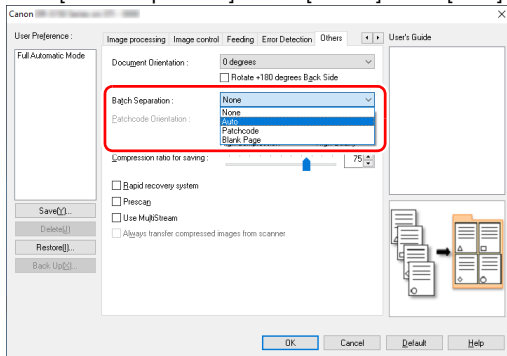

When [Batch Separation] is set to [Auto], the batch is separated after the next document is placed and scanning is continued.

For more details about [Blank Page] and [Patchcode], see ["Batch Separation Using Patch Code Sheets"](#) on p. 74

When you want to use multistream settings for scanning

Windows

Multi-stream allows you to output multiple different scanned images with a single scan operation, and output scanned images with different scanning conditions for each of the front and back pages (multistream settings).

When you want to use the multistream settings for scanning, select the [Use MultiStream] checkbox on the [Others] tab to display the setting items related to multistream, and then configure the setting items in the following order.

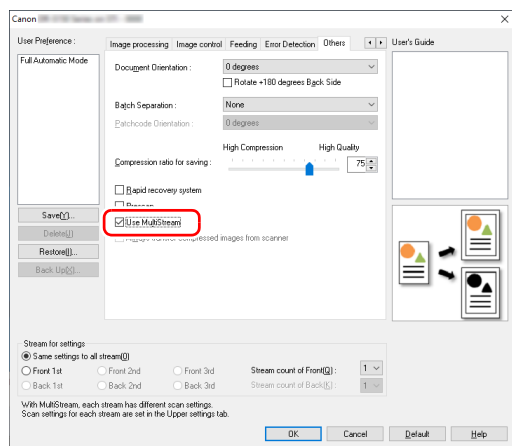

- ① When you want to specify different scanning conditions for the front and back pages of a document, select [Duplex] for [Scanning Side] on the [Basic] tab in advance.
- ② Specify the number of scanning conditions to apply in [Stream count of Front]. Up to three can be specified.
- ③ Select [Front 1st], and then open the other tabs and set the scanning conditions. Depending on the value specified for [Stream count of Front], configure the remaining [Front 2nd] and [Front 3rd] in the same way.

- ④ When specifying the scanning conditions of the back, configure the settings in the same way as described in ② to ③. In this case, specify [Stream count of Back], and then set the scanning conditions for each of [Back 1st] to [Back 3rd].

Hint

The following shows the setting conditions that can be set in the multistream settings.

Tab	Items that can be set
[Basic] tab	[Color mode] and [Dots per inch] (excluding [Auto-detection] for both)
[Brightness] tab	[Brightness] and [Contrast]
[Image processing] tab	[Color drop-out] and [Character Emphasis]
[Image control] tab	[Edge emphasis]
[Feeding] Tab	None (all disabled)
[Error Detection] tab	None (all disabled)
[Others] Tab	None (only [Use MultiStream] is enabled)

When you want to remove dots and notches that appear in documents

Windows

You can remove dots and notches protruding from object outlines that appear in documents from scanned images.

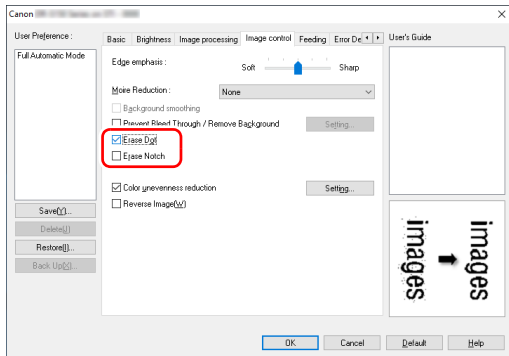

- Select the [Erase Dot] check box to automatically remove isolated black dots (3 x 3 dot size) from white backgrounds (or white dots from black backgrounds).
- Select the [Erase Notch] check box to remove notches that protrude from object outlines in scanned images.

Mac

Click [Image processing] and select [ON] for [Erase Dot] or [Erase Notch] in the dialog box that appears.

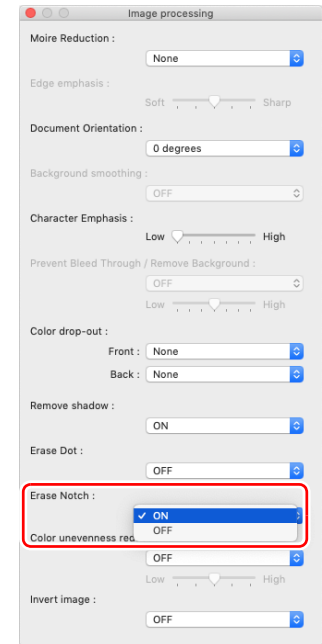
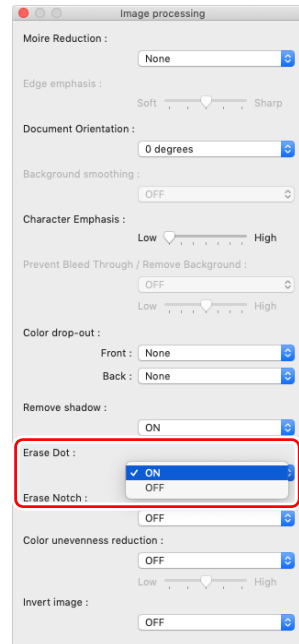

- When [ON] is selected for [Erase Dot], the isolated 3x3 black dots on white backgrounds (or isolated 3x3 white dots on black backgrounds) are erased automatically.
- When [ON] is selected for [Erase Notch], the portions (notches) protruding outside the contours are erased from the scanned images.

When you want to save a scanner driver setting

Windows

When you finish configuring a setting, click the [Save] button of [User Preference] to save the setting.

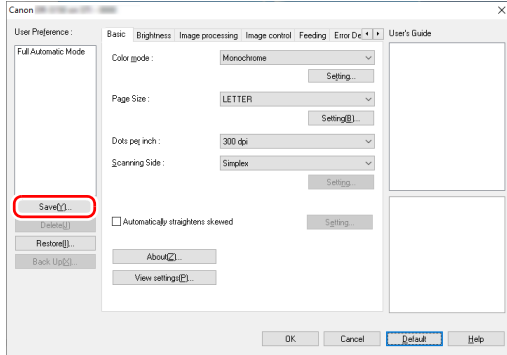

The saved setting is registered to the list. You can delete a setting from the list with the [Delete] button, and save or load a configuration file with the [Back Up] or [Restore] button.

Mac

When you finish configuring a setting, select [Add/Delete] of [Favorite Settings] to save the setting.

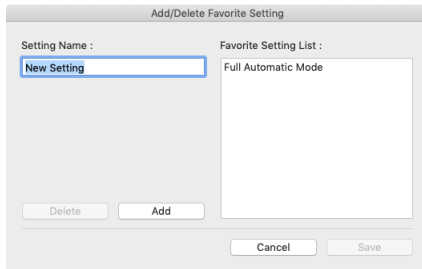

Clicking the [Add] button registers the current setting to [Favorite Setting List]. Use the [Delete] button to delete a setting from the list.

Function Restrictions Depending on Color Mode Setting

→ Windows

→ Mac

Windows

Some of the setting items in each of the driver tabs are disabled as follows depending on the setting for [Color Mode] on the [Basic] tab.

[Brightness] tab

Setting value	Contrast
Detect Automatically	✓
Active Threshold	✓
Black and White	✓
Error Diffusion	✓
Advanced Text Enhancement	
Advanced Text Enhancement II	✓
Grayscale	✓
Color	✓

(✓: Available for setting)

[Others] Tab

Setting value	Prescan
Detect Automatically	
Active Threshold	✓
Black and White	✓
Error Diffusion	✓
Advanced Text Enhancement	✓
Advanced Text Enhancement II	✓
Grayscale	✓
Color	✓

(✓: Available for setting)

[Image processing] tab

Setting value	Color drop-out	Character Emphasis
Detect Automatically		✓ ³⁾
Active Threshold	✓	✓
Black and White	✓	✓
Error Diffusion	✓	✓
Advanced Text Enhancement	✓	✓
Advanced Text Enhancement II	✓	✓
Grayscale	✓	
Color		

(✓: Available for setting)

[Image control] tab

Setting value	Edge emphasis	Background smoothing	Character Emphasis	Prevent Bleed Through / Remove Background	Color drop-out	Erase Dot	Erase Notch
Detect Automatically	✓	✓	✓ ¹⁾	✓ ¹⁾		✓ ²⁾	✓ ³⁾
Active Threshold			✓		✓	✓	✓
Black and White	✓		✓	✓	✓	✓	✓
Error Diffusion	✓		✓	✓	✓		✓
Advanced Text Enhancement	✓		✓		✓	✓	✓
Advanced Text Enhancement II			✓		✓	✓	✓
Grayscale	✓	✓		✓	✓		
Color	✓	✓		✓			

✓: Available for setting)

¹⁾Not available for setting if all of the following conditions in the [Auto Image Type Detection Settings] dialog box are met.

- [Detection mode] is not set to [Color or Gray]
- [Mode in case of binary] in the [Settings for in case of binary] tab is set to [Advanced Text Enhancement], [Advanced Text Enhancement II], or [Active Threshold]

²⁾Not available for setting if either one of the following two conditions are met.

- [Detection mode] in the [Auto Image Type Detection Settings] dialog box is set to [Color or Gray]
- [Mode in case of binary] in the [Settings for in case of binary] tab is set to [Error Diffusion]

³⁾Not available for setting if [Detection mode] is set to [Color or Gray] in the [Auto Image Type Detection Settings] dialog box.

Mac

Some of the setting items are disabled as follows depending on the setting for [Color Mode] in the settings screen of the scanner driver.

Simple Mode

Setting value	Check the image of the first page
Detect automatically	
Black and White	✓
Error Diffusion	✓
Advanced Text Enhancement II	✓
256-level Gray	✓
24-bit Color	✓

✓: Available for setting

Advanced Mode

Setting value	Enable Back Side Brightness	Enable Back Side Contrast	Check the image of the first page
Detect automatically	✓	✓	
Black and White	✓	✓	✓
Error Diffusion	✓	✓	✓
Advanced Text Enhancement II			✓
256-level Gray	✓	✓	✓
24-bit Color	✓	✓	✓

✓: Available for setting

Advanced mode (Image processing dialog)

Setting value	Edge emphasis	Background smoothing	Character Emphasis	Prevent Bleed Through / Remove Background	Color drop-out	Erase Dot	Erase Notch
Detect automatically	✓	✓ ¹⁾					
Active Threshold			✓		✓	✓	✓
Black and White	✓		✓	✓	✓	✓	✓
Error Diffusion	✓		✓	✓	✓		✓
Advanced Text Enhancement II			✓		✓	✓	✓
256-level Gray	✓	✓		✓	✓		
24-bit Color	✓	✓		✓	✓		

✓: Available for setting

1) Cannot be set if the [Detect automatically] setting matches the conditions below

- [Detection Mode] is not set to [Color or Gray]

More Advanced Scanning Methods (Batch Separation)

Windows

Batch Separation (Insert blank page)

Recognizes blank pages as batch separators and performs batch separation (automatic file separation) when documents containing blank pages are scanned.

On the [Others] tab of the driver properties, select [Blank Page] from the Batch Separation dropdown list.

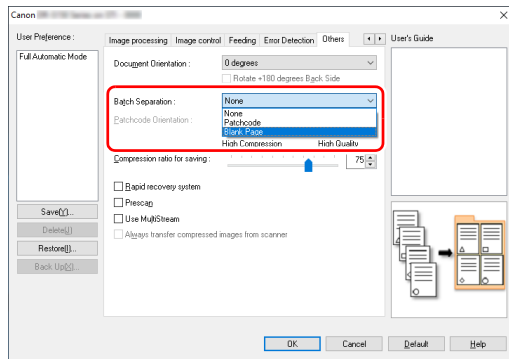

! IMPORTANT

- When [Simplex] is selected in [Scanning Side], blank pages on the scanned side will be recognized as separators. When [Duplex], [Skip blank page], or [Folio] is selected in [Scanning Side], document pages will be recognized as separators when both sides of a page are blank.
- Images of pages recognized as separators will not be saved.

Batch Separation Using Patch Code Sheets

R50 supports batch separation (automatic file separation) functions by using patchcodes.

By tucking patchcode sheets supplied with this scanner into a document and scanning it, the scanner can automatically separate files by images of documents containing patchcode sheets (or documents after the patchcode sheet).

💡 Hint

Patchcodes are included with this product in PDF format. Applications that can read PDF files are required to use this function.

The following patchcodes are installed together with the scanner driver as PDF files.

Type of Patchcode	Pattern	Description
PATCH T (FILE A)		Files are separated from the page after the page printed with this patchcode. You specify in the application whether to include the page printed with the patchcode in the scanned image.
PATCH II (FILE B)		Files are separated from the page printed with this patchcode. The page with the printed patchcode is always included in the scanned image.

The following operations are performed when using patchcodes for scanning.

1 Print patchcode with a printer.

Click [Start] – [Canon R50] and then select [Patchcode] from the menu.

Patchcodes can be printed in A4 and letter (LTR) sizes. Open the application and print a patchcode that is the same size as the document to be scanned.

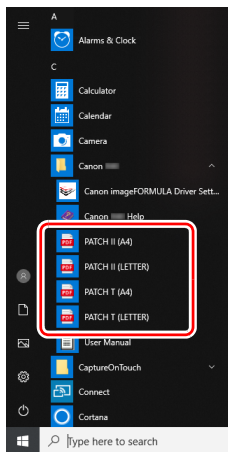

Hint

In Windows 8.1, it is registered at the following location.

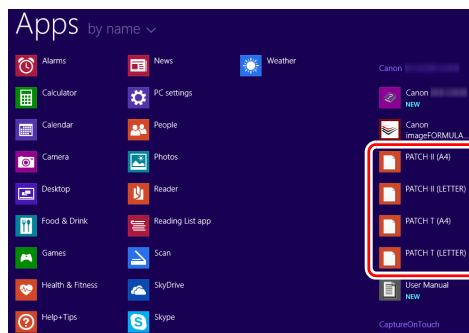

! IMPORTANT

- Patchcodes must be printed in their normal size. If patchcodes are enlarged or reduced, they may not be recognized correctly.
- When copying provided patchcodes to create different sized patchcodes, ensure that the patchcode fits inside the effective range shown in the following diagram. Also, when copying patchcodes, ensure that they are the same size and shade as the original.

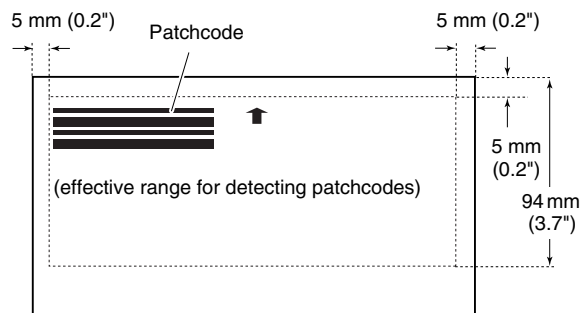

- Keep the patchcode sheet clean. Take particular care to keep the patchcode detection range area clean. Also, do not bend, fold or crease the sheet.

-
- 2** Place the documents in the scanner after inserting the patchcode sheet in front of the page that separates the files.

Insert the patchcode sheets at the beginning of documents to change file separation.

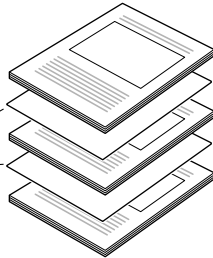

-
- 3** In an application, specify a patchcode as a type of batch separation.

Open the scanner driver settings screen and select [Patchcode] in [Batch Separation] on the [Others] tab.

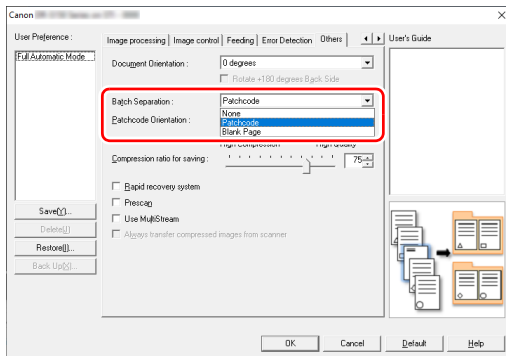

Using the Web Menu

The Web menu is used to display information about the scanner, to set up the network when connecting via Wi-Fi, and to configure various Web services. Scanner settings can be configured using a Web browser.

! IMPORTANT

- We recommend the following Web browsers:

Windows	Microsoft Internet Explorer 11 or later
	Microsoft Edge 42 or later
	Firefox 61.0.1 or later
	Chrome 75.0 or later
macOS	Safari 4.0.0 or later

- In examples in the following instructions use Internet Explorer 11 and Windows 10. Displays vary depending on the Web browser.

Displaying the Scanner's Web Menu

- 1 Displays a list of connected scanners.**

→ **Windows**

→ **Mac**

- 2 Select the scanner from the list, and click [Properties].**

The scanner's Web page opens, and the login screen is displayed.

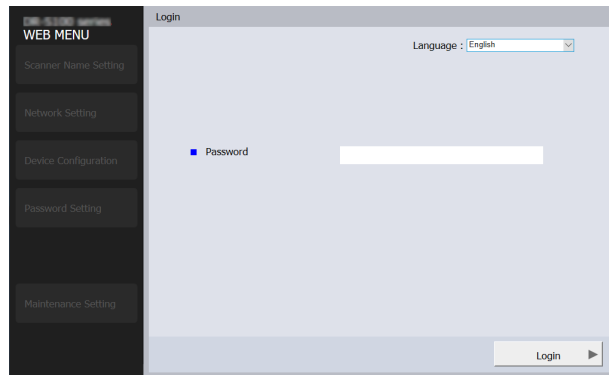

- 3 Select a display language for the Web page in the [Language] list box.**

- 4 Enter the administrator password in [Password].**

If the machine is a 120V model, the administrator's password may be written on a label that is attached to the machine when it is shipped from the factory. When you open the Web menu for the first time, refer to this label and input the password.

If the password is not on a label, or if the machine is not a 120V model, then the administrator's password was not set when the machine was shipped from the factory. When you open the Web menu for the first time, proceed to the next procedure without inputting anything.

If the administrator's password has already been changed on the Web menu, input that password.

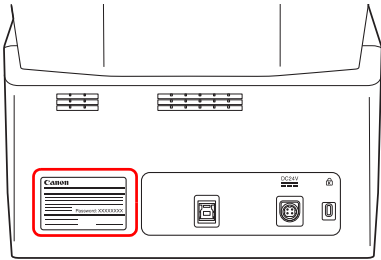

! IMPORTANT

To ensure security, we recommend changing the administrator password without leaving it as shipped from the factory. Change the password in the [Password Setting] screen of the Web menu. "Password Setting" (See p. 85)

5 Click [Login].

The [Device information] screen appears.

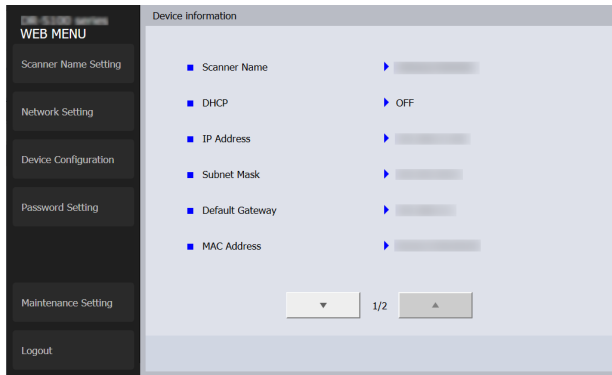

Windows

- 1 Open the Canon imageFORMULA Driver Setting Tool's Settings screen. (See p. 94)
- 2 Click the [Network monitor] tab.

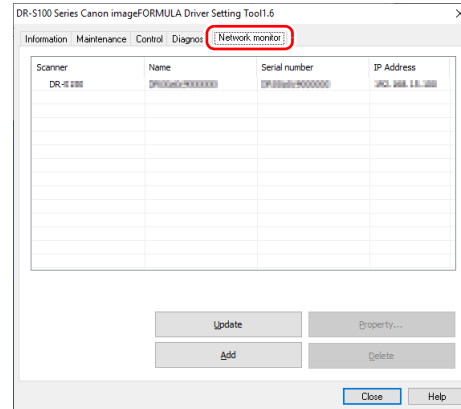

Mac

- 1 On the Finder menu bar, click [Go] - [Applications]. Double-click [WebScanSettingTool]. WebScanSettingTool starts.

Web Menu Pages

When you click the items on the left menu, the following pages are displayed.

Scanner Name Setting: Displays the scanner name.

Network Setting: Configures the network settings.

Device Configuration: Configures the mDNS, SNMP, PIN settings.

Password Setting: Configures the administrator password used to log into the Web menu.

Maintenance Setting: Restores the factory default settings and updates the firmware.



Hint

To return to the [Device information] screen from one of its settings screens, click the model name of the scanner that appears at the top of the left menu.

Web Menu Settings

This section describes the setting items on each of the Web menu pages.

Scanner Name Setting

If you click [Scanner Name Setting] on the left menu, the page below is displayed.

Item	Description
Scanner Name	Sets the scanner name.

Network Setting

If you click [Network Setting] on the left menu, the page below is displayed.

Item	Description	Default Value
DHCP	Enable ([ON]) / disable ([OFF]) the DHCP protocol. To assign an IP address using DHCP, the DHCP server must be running in your subnetwork.	ON
IP Address	Set the IP address of the scanner. If DHCP is enabled, the IP address obtained from it will be applied. The value must be four decimal numbers separated by dots and expressed in the [xxx.xxx.xxx.xxx] format.	None

Item	Description	Default Value
Subnet Mask	Set the subnet mask of the scanner. If DHCP is enabled, it provides the subnet mask. The value must be four decimal numbers separated by dots and expressed in the [xxx.xxx.xxx.xxx] format. When set to [0.0.0.0], a subnet mask appropriate for the IP address is automatically used.	None
Default Gateway	Set the IP address of the scanner gateway. If DHCP is enabled, it provides the default gateway. The value must be four decimal numbers separated by dots and expressed in the [xxx.xxx.xxx.xxx] format. Also, the gateway needs to be running in the same subnetwork as the scanner. If [0.0.0.0] is set, this setting is disabled.	None

Device Configuration

If you click [Device Configuration] on the left menu, the page below is displayed.

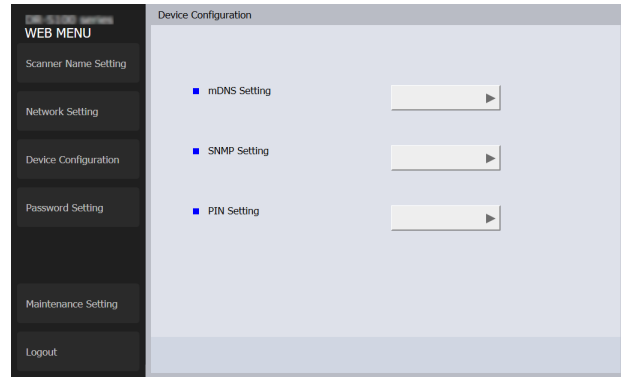

Item	Description
mDNS Setting	Moves to the mDNS Setting screen.
SNMP Setting	Moves to the SNMP Setting screen.
PIN Setting	Moves to the PINSetting screen.

mDNS Setting

If you click [mDNS Setting] on the Device Configuration screen, the page below is displayed.



Item	Description	Default Value
mDNS	Enable/disable multicast DNS. This setting allows scanning applications to search for and automatically connect to the scanner. This is normally enabled. When the setting is disabled, you must manually specify the scanner using its assigned IP address to scan from the scanning application.	ON

SNMP Setting

If you click [SNMP Setting] on the Device Configuration screen, the page below is displayed.

Item	Description	Default Value
SNMP Service	Sets the SNMP function to enabled/disabled.	OFF
Location	Input the location where the scanner is installed.	None

Item	Description	Default Value
Security - Auth trap	Sets the SNMP authentication trap function to enabled/disabled. By setting this to [ON], if an SNMP request is received from a community that is not registered in [Community Setting], then a message is sent to the trap destination.	OFF
SNMP v1	Sets the SNMP v1 support function to enabled/disabled.	OFF
Community Setting	Moves to the [Community Setting] screen.	-
SNMP v3	Sets the SNMP v3 support function to enabled/disabled.	OFF
User Setting	Moves to the [User Setting] screen.	-

Community Setting

In the SNMP settings screen, enable SNMP v1 and click [Community Setting] to open the page shown in the following diagram.

Item	Description
New	Register a new community. Click to open a dialog box for editing the various settings for a community. Up to three communities can be registered.
Modify	Change the settings of the selected community. Click to open a dialog box for editing the various settings for a community.
Delete	Delete the selected community.
Detail info	Display the settings of the selected community. Click to open a dialog box for browsing the various settings for community.

Edit dialog box of community

Clicking [New] or [Modify] in the community settings screen opens the following page.

Item	Description	Default Value
Community name	Set a community name within 32 characters. You can use single-byte letters, numbers, hyphens, and underbars. An error appears when you press the [Apply] button if the name is already being used or contains illegal characters.	None
MIB access restrict	Set either [Read/Write] or [Read only] as the user rights.	Read only
Host filtering	Sets permission to access the host. All hosts: Permits access to all hosts. Listed hosts: Permits access only to hosts specified in [Accepted hosts list].	All hosts
Accepted hosts list	To specify a host to be accessed, input its IP address or computer name. You can specify a maximum of 5. You can input up to 64 characters in each line.	None
Trap setting	Select ON/OFF for trap setting.	ON
Trap destinations	To specify a host to be targeted for trap setting, input its IP address or computer name. You can specify a maximum of 5. You can input up to 64 characters in each line.	None

User Setting

In the SNMP settings screen, enable the SNMP v3 support function and click [User Setting] to open the page shown in the following diagram.

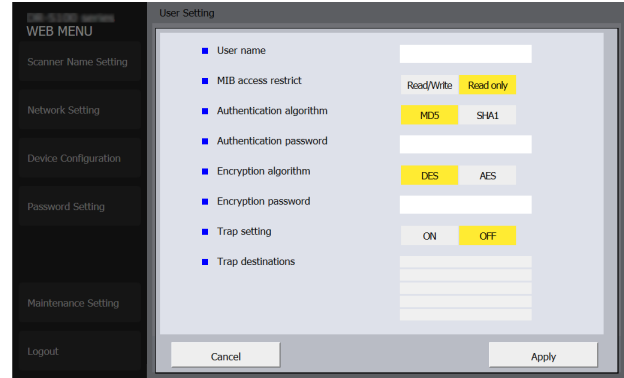
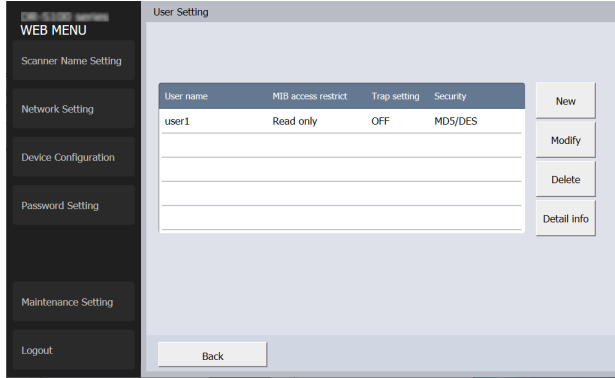

Item	Description
New	Register a new user. Click to open a dialog box for editing the various settings for a user. Up to five users can be registered.
Modify	Change the settings of the selected user. Click to open a dialog box for editing the various settings for a user.
Delete	Delete the selected user.
Detail info	Display the settings of the selected user. Click to open a dialog box for browsing the various settings for a user.

Edit dialog box of user

Clicking [New] or [Modify] in the user settings screen opens the following page.

Item	Description	Default Value
User name	Set a user name within 32 characters. You can use single-byte letters, numbers, hyphens, and underbars. An error appears when you press the [Apply] button if the name is already being used or contains illegal characters.	None
MIB access restrict	Set either [Read/Write] or [Read only] as the user rights.	Read only
Authentication algorithm	Specify MD5 or SHA1 as the authentication method.	MD5
Authentication password	Set an authentication password using 8 to 16 characters. You can use single-byte letters, numbers, hyphens, and underbars. An error appears when you press the [Apply] button if you input any illegal characters.	None
Encryption algorithm	Specify DES or AES as the encryption method.	DES

Item	Description	Default Value
Encryption password	Set an encrypted password using 8 to 16 characters. You can use single-byte letters, numbers, hyphens, and underbars. An error appears when you press the [Apply] button if you input any illegal characters.	None
Trap setting	Select ON/OFF for trap setting.	ON
Trap destinations	To specify a host to be targeted for trap setting, input its IP address or computer name. You can specify a maximum of 5. You can input up to 64 characters in each line.	None

PIN Setting

If you click [PIN Setting] on the Device Configuration menu, the page below is displayed.

Item	Description	Default Value
Enable PIN	Enable ([ON]) / disable ([OFF]) PIN.	OFF

Item	Description	Default Value
Current PIN	Enter the currently set PIN.	0000
New PIN	Enter a new PIN.	None
New PIN (Confirmation)	Use to confirm the new PIN that has been entered.	None

Password Setting

If you click [Password Setting] on the left menu, the page below is displayed.

Item	Description	Default Value
Current Password	Enter the current password.	See p. 77
New Password	Set the administrator password (up to 32 characters) for the scanner. This password is used for authentication when configuring settings by Web browser.	None

Item	Description	Default Value
New Password (Confirmation)	Used to confirm the password.	None

Maintenance Setting

If you click [Maintenance Setting] on the left menu, the page below is displayed.

On this page, you can restore the scanner's factory default settings and update the firmware.

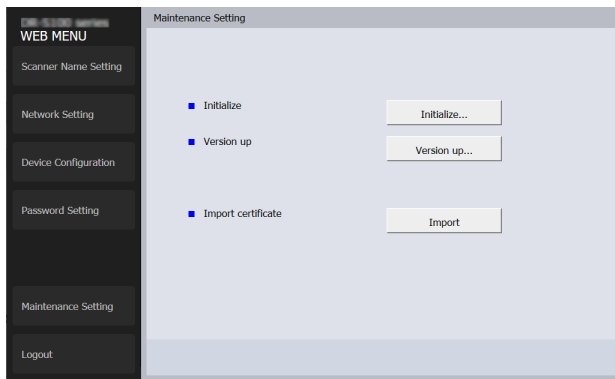

Item	Description
Import certificate	You can load and change the server certificate used to access the Web menu with "https://". Click the [Import] button, and the [Import certificate] dialog appears. Specify the certificate file (pfx file) and click [Send] to import.

Item	Description
Initialize	Restore the scanner's factory default settings. If you click [Initialize] and then [Yes] in the screen that appears, the scanner's factory default settings are restored, and the scanner restarts.
Version up	Update the scanner's firmware. Click [Version up], and specify the firmware file in the screen that appears.

Daily Maintenance

Clean the scanner on a regular basis, as described below, to maintain peak scanning quality.

CAUTION

- When cleaning the scanner and the inside of the scanner, turn OFF the power switch and disconnect the power cord from the power outlet.
- Do not use spray cleaners to clean the scanner. Precision mechanisms, such as the light source, may get wet, and cause a malfunction.
- Never use paint thinner, alcohol, or other organic solvents to clean the scanner. The exterior of the scanner may become deformed, discolored, or melted. It may also cause a fire or electric shock.

Cleaning the Scanner

To clean the outside of the scanner, wipe off any dirt with a cloth that has been dampened with water and thoroughly wrung out, and then wipe the scanner dry with a clean dry cloth.

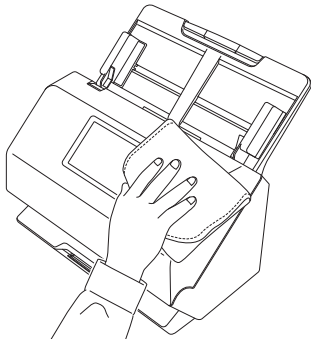

Cleaning the touch panel

To clean the touch panel, use a soft dry cloth to lightly wipe the surface of the panel, without applying any pressure.

Cleaning the Inside of the Scanner

Dust or paper particles inside the scanner may cause lines or smudges to appear on scanned images. Use compressed air to periodically clean dust and paper particles from the document feed opening and the inside of the scanner. After finishing a large scanning job, turn OFF the scanner and then clean out any paper particles remaining inside the scanner.

Cleaning the Sensor Glass and the Rollers

If scanned images contain streaks, or if the scanned documents become dirty, the sensor glass or rollers inside the scanner may be dirty. Clean them periodically.

- 1** Pull the OPEN lever and pull open the front unit toward you.

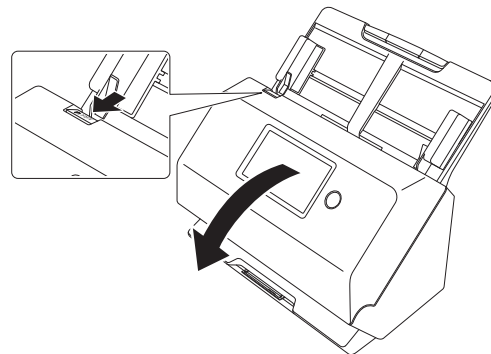

- 2** Use compressed air to remove dust and paper particles from the inside of the scanner.

3 Wipe any dirt off the scanning glass.

Wipe any dirt off the scanning glass with a cloth that has been dampened with water and thoroughly wrung out, and then wipe the glass dry with a clean, dry and soft cloth.

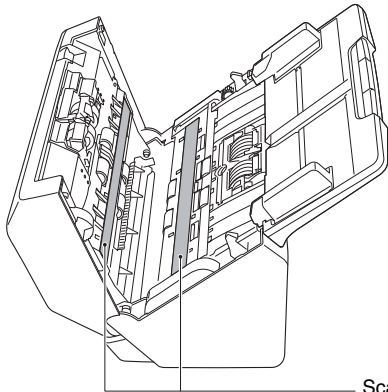

CAUTION

Do not spray water or neutral detergent directly on the scanner. Precision mechanisms, such as the light source, may get wet, and cause a malfunction.

IMPORTANT

- Scratches on the sensor glass may cause marks on the images, as well as feeding errors. If there are scratches on the sensor glass, contact your local authorized Canon dealer or service representative.
- Take care to ensure the anti-static brush in the front unit does not become deformed.

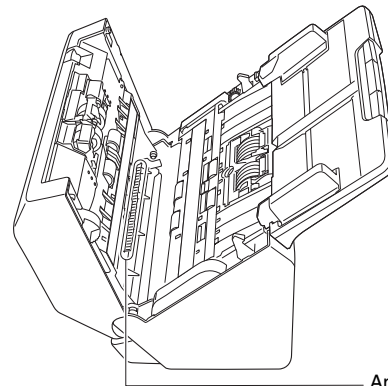

4 Clean the rollers.

Clean the rollers while turning them.

Wipe the rollers with a cloth that has been dampened with water and thoroughly wrung out, and then use a clean, dry and soft cloth to wipe away any moisture.

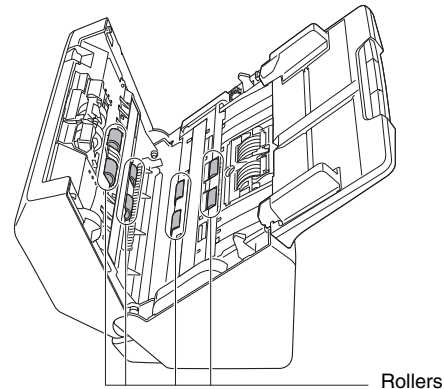

5 Remove the retard roller and feed roller. (See p. 91, p. 92)

! IMPORTANT

Remove the retard roller and feed roller from the scanner to clean them, and be sure to reattach them to the scanner when cleaning is finished.

6 Wipe the removed rollers with a cloth that has been dampened with water and thoroughly wrung out.

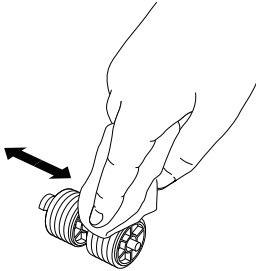

7 Reattach the retard roller and feeding roller. (See p. 91, p. 92)

8 Close the front unit by gently pushing it up on both sides until it clicks into place. Make sure that the front unit is completely closed by pushing until you hear a click.

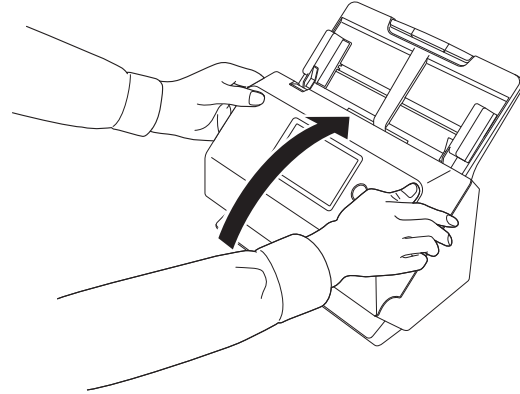

Replacing Consumable Parts

The two rollers (feed roller and retard roller) installed in the scanner are consumable parts. The feed roller and retard roller wear with scanning. If the feed roller and retard roller are worn, documents may not feed correctly and paper jams and double feeds may occur. When more than 200,000 pages have been fed (total number of pages fed by the scanner), a message prompting you to replace the rollers is displayed when the computer and scanner are started.

Message that appears on the computer

Windows

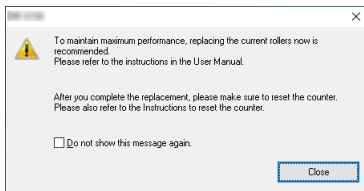

Mac

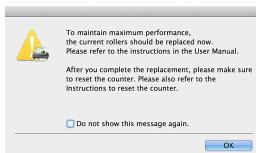

Message that appears on the touch panel

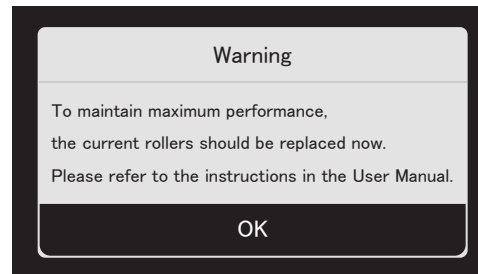

Tap [OK] to move to the home screen.

The message that appeared on the panel can be cleared by resetting the roller counter. Note that, it will always appear whenever the scanner's power is turned on, until you reset the roller counter.

If this message begins to be displayed at startup, purchase an exchange roller kit and replace the worn parts with the consumable parts included in the kit (feed roller and retard roller). [See p. 109](#) for details about the exchange roller kit.

Furthermore, the counter in the scanner that records the number of pages fed also needs to be reset when you replace the rollers. ([See p. 93](#))

Hint

Even before it becomes time to replace the rollers, scanned images may become stretched in the vertical direction due to wear of the rollers. If this happens, adjust the reduction ratio. ([See p. 94](#))

Opening and Closing the Front Unit

- 1 Pull the OPEN lever and pull open the front unit toward you.

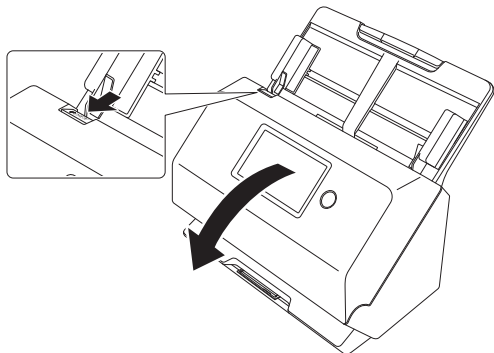

Hint

The location of each of the consumable parts is shown below.

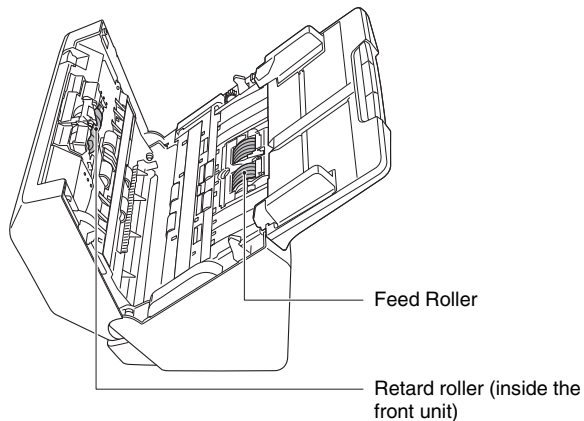

- 2 When closing the front unit, make sure that it is completely closed by gently pressing the left and right until you hear a click.

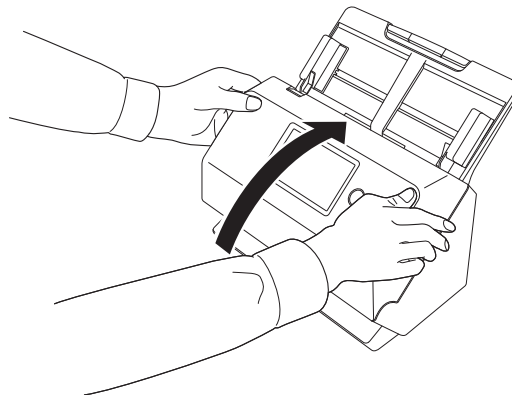

Replacing the Feed Roller

- 1 Open the roller cover.

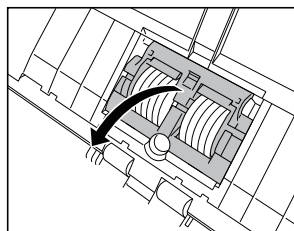

2 Remove the feed roller.

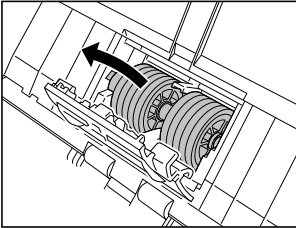

3 Install the new feed roller.

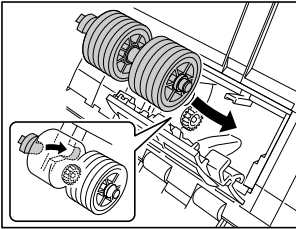

4 Close the roller cover.

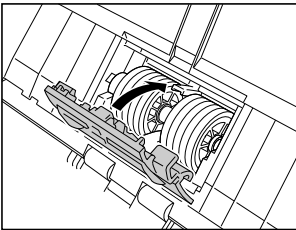

Replacing the Retard Roller

1 Open the roller cover.

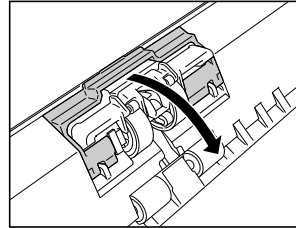

2 Pull the left lever that secures the retard roller to the scanner, and remove the roller.

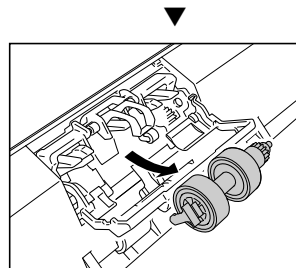
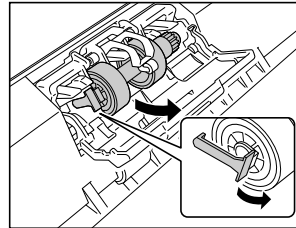

-
- 3** Install the new retard roller by inserting the right side first.

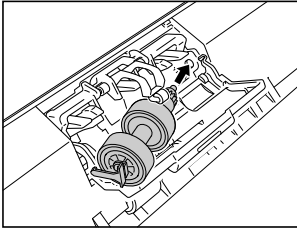

-
- 4** Push the left side of the retard roller to secure it to the scanner.

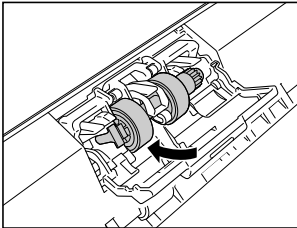

-
- 5** Close the roller cover.

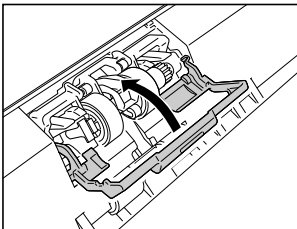

Resetting the counter

-
- 1** Tap  (Settings) button on the touch panel.
The settings menu screen appears.

-
- 2** Tap [Maintenance] and then [Roller Feed Count], in that order.

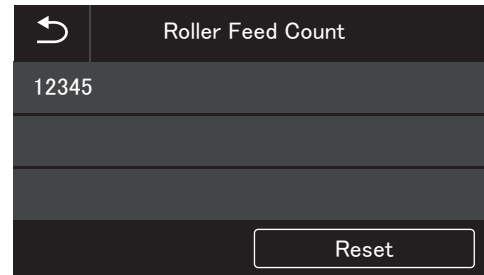

-
- 3** Tap [Reset] to open the following message.

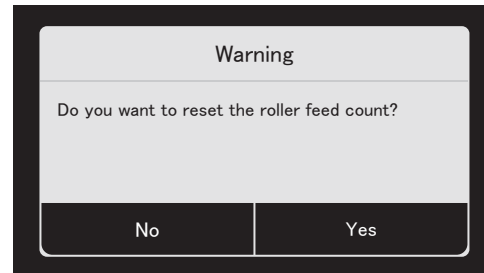

-
- 4** Tap [Yes].

-
- 5** The value in [Roller Feed Count] is reset.

-
- 6** Tap the  (Back) button to return to the original screen.



Hint

A counter reset is done from the Canon imageFORMULA Driver Setting Tool. (See p. 94)

Removing the Document Feed Tray

When you will store or otherwise not use the scanner for a long period of time, remove the document feed tray.

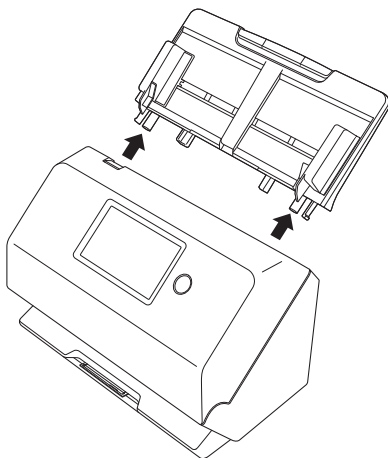

About the Canon imageFORMULA Driver Setting Tool

What is Canon imageFORMULA Driver Setting Tool?

The Canon imageFORMULA Driver Setting Tool can be used to check the information of the scanner, or to configure the maintenance settings.

Canon imageFORMULA Driver Setting Tool consists of the following tabs.

[Information] tab

You can check the firmware's version information and scanner information.

[Maintenance] tab

You can reset the counter of the roller, or carry out the shrinkage rate control.

[Control] tab

You can carry out the control settings of hardware and drivers, and perform the read or write of the control settings.

From the configuration of the hardware, you can set the automatic power-off function.

[Diagnostic] tab

You can output or delete the log file.

[Network monitor] tab

You can see the scanners on the network. You can also display a Web menu screen to make various scanner settings. "Web Menu" (See p. 77)



IMPORTANT

A USB connection is required to make this setting with the Canon imageFORMULA Driver Setting Tool. When connected via Wi-Fi, making this setting with the Canon imageFORMULA Driver Setting Tool is ineffective.

Start-up of the Canon imageFORMULA Driver Setting Tool

Click the Start button, then click [Canon R50] - [Canon imageFORMULA Driver Setting Tool] in that order. Canon imageFORMULA Driver Setting Tool will start.

 **Hint**

In Windows 8.1, it is registered at the following location.

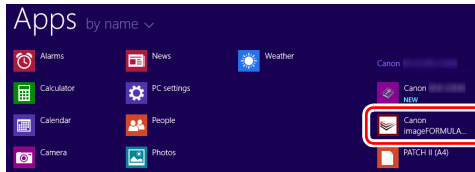

Common Problems and Solutions

This section provides recommended solutions to common problems. If you have a problem that is not solved by the following, contact your local authorized Canon dealer.

Problem 1 The scanner will not turn on.

Solutions Confirm that the AC adapter is plugged firmly into a power outlet.

Problem 2 Cannot Scan

Solutions If you have more than one of the same model scanner, one of them may be being used unintentionally because it is selected in the software or operations may have been done directly to the scanner. Check again, which scanners are selected.

Problem 3 The scanner is not recognized.

Solutions When connecting via USB:

- (1) Confirm that the scanner is properly connected to the computer with a USB cable.
- (2) Confirm that the scanner is turned on. See the previous problem (1) if the scanner does not turn on.
- (3) The computer's USB interface may not support the scanner. The scanner cannot be guaranteed to work with all USB interfaces.
- (4) Confirm that the supplied USB cable is used to connect the scanner to the computer. The scanner cannot be guaranteed to work with all available USB cables.
- (5) If the scanner is connected to the computer via a USB hub, try removing the hub and connecting directly to the computer.
- (6) USB connections are not recognized when connected via Wi-Fi. Operate the touch panel to switch the connection method. (See p. 38)

When connecting via Wi-Fi:

- (1) Confirm that the IP address is configured properly.
- (2) If a DHCP server does not exist on the network, you need to use a static IP address. Do the settings from the touch panel (See p. 38) or from the network settings on the Web menu (See p. 80).
- (3) You cannot connect if the connected segment is different. Please set it to the same segment as your computer. For details, please contact your network administrator.
- (4) Connection may not be possible due to security software settings. For details, please contact your network administrator.
- (5) You cannot connect if the same device exists on multiple networks and you specify a device with a different IP address. Please double check the IP address of the device to be used.
- (6) Use the following procedure to configure the firewall and open the mDNS port.
 1. Click the [Start] button, and then click [Windows System] – [Control Panel].
 2. Click [System and Security].
 3. Click [Windows Defender Firewall].
 4. Click [Advanced settings] to open the [Windows Defender Firewall with Advanced Security] window.
 5. Click [Inbound Rules].
 6. Click [New Rule] to open the [New Inbound Rule Wizard].
 7. Click [Custom], and then click [Next].
 8. Select [This program path]. Specify the following path and click [Next].
C:\ProgramFiles(x86)\Canon Electronics\
SharedFiles\DriverNetworkMonitor.exe

-
9. Set each item as follows, and then click [Next].
 - Protocol type: UDP
 - Local port: Specific Ports
 - Port Number: 5353
 - Remote port: Specific Ports
 - Port Number: 5353
 10. Select [Any IP address] for both local IP address and remote IP address, and then click [Next].
 11. Select [Allow the connection], and then click [Next].
 12. Specify when the rule is applied, and then click [Next].
 13. Enter a name, and then click [Finish].
- (7) Confirm that the access point is operating correctly.
 - (8) Turn both this scanner and the access point off and back on, and attempt the Wi-Fi connection again.
 - (9) The scanner may be positioned too far from the access point. Connection is not possible if the distance is too far.
 - (10) There may be a wall or furniture between the access point and the scanner that is blocking the connection. Reposition the devices or move them closer together.
 - (11) Cordless phones, microwave ovens and radio signals from other appliances can interfere with Wi-Fi signals. Keep Wi-Fi devices away from such appliances.
 - (12) When an access point's stealth function is enabled, it cannot be detected during Wi-Fi setup. Disable the stealth function or use manual setup to enter the correct SSID of the access point.
 - (13) When the access point's MAC filtering function is enabled, the MAC address of this scanner must be registered.
 - (14) Wi-Fi connections are not recognized when connected via USB. Operate the touch panel to switch the connection method. (See p. 38)

Problem 4 The scanner turned off automatically.

Solutions When the scanner's auto power off function is enabled, the scanner's power is automatically turned off after 4 hours, regardless of whether a connection is active. Turn the scanner back on, and as necessary, disable the Auto Power Off.

Problem 5 I want to reset to the factory default settings.

Solutions The scanner's initialization is done on the touch panel settings menu (See p. 37) or the Web menu on the browser (See p. 86).

Problem 6 Automatic connection to the network is not possible.

Solutions If your network environment supports DHCP, consult your network administrator. If your network environment does not support DHCP, configure the IP address manually.

Problem 7 After doing settings on the Wireless Connection Tool, an error occurs and the scanner cannot be used (or found).

Solutions Immediately after setup with the Wireless Connection Tool, the computer's network connection may be unstable. Please wait for a while or restart the computer.

Problem 8 Documents feed askew (scanned images are slanted).

- Solutions
- (1) Align the document guides to fit the documents as closely as possible, and load the documents so that they feed straightly.
 - (2) Open the document feed extension support and place the document.
 - (3) Enable [Automatically straightens skewed] in the scanner driver settings.
 - (4) If many pages have been scanned since roller cleaning, clean the rollers. If documents still feed askew, roller replacement or other maintenance may be needed. See "Maintenance" on p. 87 for roller replacement procedures.

Problem 9 Documents are not scanned according to the settings configured in the scanner driver.

Solutions

When you scan using [Select document] panel registered with CaptureOnTouch, the CaptureOnTouch settings have priority over the scanner driver settings. Edit settings in the [Select document] panel, or create a new [Select document] panel using the desired scanning conditions.

Problem 10 If white lines or streaks appear in scanned images.

Solutions

Clean both sides of the scanner glass, and the rollers. If a sticky substance such as glue or correction fluid is found, carefully wipe with just enough pressure to clean the area where the lines appear. If the problem cannot be solved by cleaning, the internal glass may be scratched. Contact your local authorized Canon dealer.

Problem 11 Pages are missing.

Solutions

When the scanner driver's [Scanning Side] setting is [Skip Blank Page], documents with very little black may be unintentionally skipped. Decrease the Set the likelihood of skipping blank page value ("When you want to delete the images of the blank pages in two-sided documents" on p. 59) or set the [Scanning Side] to another mode, such as simplex or duplex. If pages are skipped due to the document double feeding, see "Problem 12 Documents jam (or double-feed)."

Problem 12 Documents jam (or double-feed).

- Solutions
- (1) If the roller has been installed correctly, clean it if necessary.
 - (2) Proper scanning may not be possible when document pages stick together due to static electricity. Fan the documents before you load them.
 - (3) Manually feed the scanner one page at a time.

Problem 13 Multiple pages of scanned images cannot be saved to a single file.

Solutions

Depending on the file format, multiple scanned image pages cannot be saved as a single file with CaptureOnTouch.

File type	Processing for multiple pages
BMP, JPEG	Scanned images are always saved one page per file.
PPTX	Multi-page images are always saved to a single file.
TIFF, PDF	You can save multiple pages to a single file by clicking  and selecting [Save all pages as one file] in the displayed dialog box.

Problem 14 All of the placed documents have been scanned, but the scanned image does not appear on the application.

Solutions When [Panel-Feeding] or [Automatic Feeding] is selected as the feeding method in the [Feeding] tab of the scanner driver's settings screen, a scanning operation will not continue after all of the documents are fed, as the scanner awaits additional documents to be fed. Tapping [Stop] on the touch panel ends the scanning operation and sends the scanned image to the application.

Problem 15 Memory becomes insufficient and scanning stops.

Solutions If you configure scanning conditions that use a large amount of the computer's memory, scanning may stop because of insufficient memory. Although this depends on the computer's memory size, the possibility of insufficient memory increases if any of the following scanning conditions overlap.

- [Color Mode] is set to [Color]
- A large page size (e.g. Legal) is specified as the [Page Size]. Alternatively, the page size is set to [Scanner's Maximum].
- A high resolution (600dpi etc.) is specified for [Dots per inch].

If an error message appears due to insufficient memory while scanning is in progress, exit the application, change the scanning conditions (e.g. reduce the resolution or page size) and then try scanning again. In addition, the amount of memory used can be contained by turning off [Moire Reduction] and [Prevent Bleed Through/Remove Background] if they are set to on.

Problem 16 Double-feeding occurs when scanning a document with multiple pages.

Solutions Turn on [Disable double-feed detection] on the touch panel to continue scanning (See p. 39), or set the [Detect by Ultrasonic] check box to off in the scanner driver's settings screen. (See p. 31) Or, set the [Rapid recovery system] check box on the [Others] tab on the scanner driver settings screen.

Problem 17 The size detection and deskew functions fail.

Solutions When [Document Type] is set to [Carrier sheet] in the [Feeding] tab of the scanner driver settings screen and you scan a document with black edges without inserting it in a carrier sheet, the size detection and deskew functions may fail. In such cases, disable the size detection and deskew functions, or set [Document Type] to [Plain paper] in the [Feeding] tab.

Software Troubleshooting

This section describes troubleshooting problems and solutions for operating the supplied software (CaptureOnTouch).

If scanning is too slow

- (1) Close other running programs, if any.
- (2) Scanning can be slowed down by memory shortage caused by memory-resident applications such as anti-virus programs. Close such memory-resident programs if necessary to free up memory space.
- (3) When insufficient hard disk space is available, the scanner may be unable to create the necessary temporary files for scanned data. Delete unneeded data on the hard disk to free up more space.
- (4) Scanning is slow, if the computer's USB port is not compliant with high-speed standards such as USB2.0 and USB3.2 Gen1x1.
- (5) If using a common USB cable that is not USB3.2 Gen1x1 compliant, replace the cable with the supplied compliant cable.
- (6) When the scanner is connected to the computer via a USB hub that is not USB3.2 Gen1x1 compliant, remove the hub and connect the scanner directly to the computer.
- (7) If a message is displayed on the touch panel indicating scanning in the Long Document mode, deselect the Long Document mode. [\(See p. 29\)](#)

If scanned image files cannot be opened in an application

- (1) Scanned images saved as multi-page TIFF files can be opened only by programs that support this file format.
- (2) Images saved as compressed TIFF files (single- as well as multi-page) can only be opened by programs that support the compressed format. This can occur with programs that are not compatible with CaptureOnTouch. In this case, select "None" as the image file compression format before scanning.

There is a display glitch on the UI screen of CaptureOnTouch.

Depending on the computer that you are using, a display glitch may occur on the UI screen when there are too many Scan mode panels, Select output panels, or One Touch buttons. Delete any panel that you will not use.

Useful Tips

Here are some useful tips for scanning documents.

Where are scanned images saved? Can the save destination be changed?

Images are saved to the following locations, according to program settings. All destination locations can be changed to other folders. Both Standard Scanning and One Touch scan save the output to the destination set in the [Select output] panel.

How are the scan settings configured?

By clicking the Edit button () in the [Select document] panel, you can edit the scan settings when the [Select document edit screen] opens.

How do I save multiple pages in one file, or save one file per page?

When scanned images are saved in BMP (PICT) or JPEG format, each image is always saved in a separate file.

When scanned images are saved in PDF or TIFF format, you can specify multi- or single-page files. See also “Problem 13” in “Common Problems and Solutions”.

Can I copy or back up scanner setting configurations?

The setting configurations can be backed up and restored using [BackUp]/[Restore] on the [Basic settings] tab on the [Settings] dialog box

What rules apply to scanned image file names?

For both Standard Scanning and One Touch Scan, the file names of scanned images are set based on the settings in the [Select output] panel. This screen opens when you click the Edit button () in the [Select output] panel.

Click the [Detail Settings] button on this screen. You can set the file names of scanned images by setting all or some of the three items shown below.

Setting	Description
File name	Any specified text string to be included in the file name.
Add date and time	Appends the date and time to file names. Select the date format from the list box. YYYY = year, MM = month, and DD = day of month. The time is appended after the date.
Add counter to file name	Append serial numbers in the order of scanned image saving. Specify the number of digits and starting number.

A sample file name is displayed as the [File name] in the [File name settings] dialog box.

How can I skip blank pages, and scan only non-blank pages?

Specify [Skip Blank Page] on the scanner driver setting screen, then scan.

How do I scan cards?

Set a card in landscape orientation in the scanner. Specify the same size as the card (or [Match original size]), then scan. For details, [see p. 28](#).

How do I load and scan documents with mixed sizes?

Set [Page Size] to [Match original size] on the scanner driver setting screen, then scan. For details, [see p. 56](#).

What is the best way to scan business cards or photos?

Set [Page Size] to [Match original size] on the scanner driver setting screen, then scan. Alternatively, register the size of the cards or photos to be scanned. For details, [see p. 56](#).

How do I print scanned data?

- For both Standard Scanning and One Touch Scan, select [Print] in the [Select output] panel.
- To use this function, you need to install a plug-in.
- The plug-in can be installed by selecting its checkbox when installing CaptureOnTouch.

I want to save to other folders

- In CaptureOnTouch, destinations other than [Save to folder] are provided as a plug-in.
- By installing the plug-in, the scanned image can be printed, attached in an e-mail, or shared using various cloud services.
- The plug-in can be installed by selecting its checkbox when installing CaptureOnTouch.
- The available output destinations vary depending on the installed plug-in.

How can I attach scanned data to an e-mail (or send it as e-mail)?

- For both Standard Scanning and One Touch Scan, select [Attach to E-mail] in the [Select output] panel.
- To use this function, you need to install a plug-in.
- The plug-in can be installed by selecting its checkbox when installing CaptureOnTouch.

Clearing a Paper Jam

When paper jams are detected during scanning, the following error codes are displayed in the touch panel and scanning is interrupted.

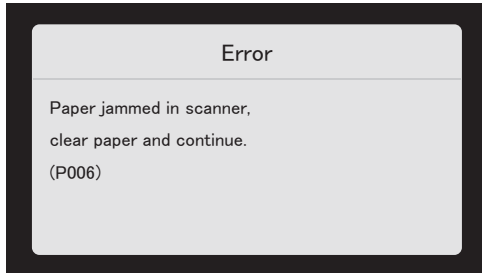

When a paper jam or double feed occurs during scanning, use the following procedures to clear them.

 **CAUTION**

Be careful when removing jammed paper. take care not to cut your hand on the edges of the paper.

- 1 Remove any documents that have been left in the feed Tray.**

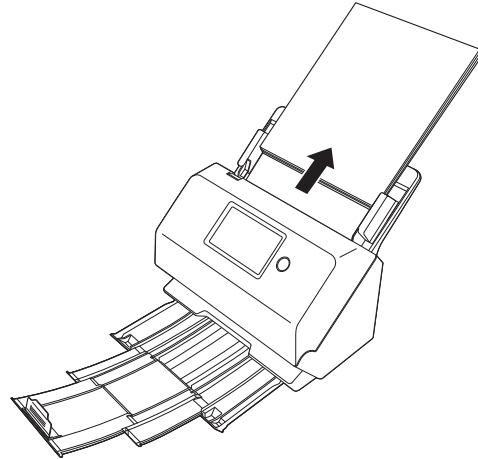

-
- 2** Pull the OPEN lever and pull open the front unit toward you.

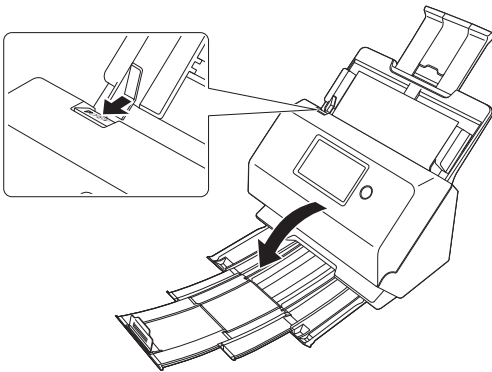

Hint

The following message appears on the touch panel when the front unit is open.

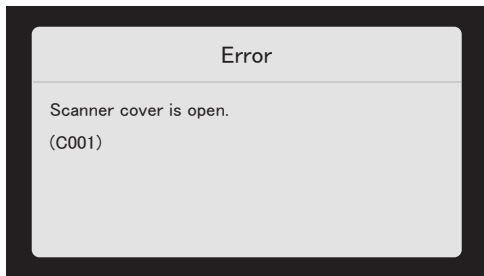

-
- 3** Remove the jammed document.

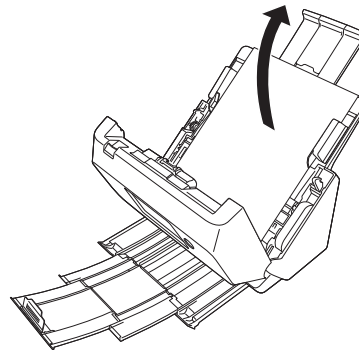

! IMPORTANT

Make sure to pull the document out carefully, without applying too much force. If the jammed paper tears while you are pulling it out, make sure to remove any remaining pieces from inside the scanner.

-
- 4** Close the front unit by gently pushing it up on both sides until it clicks into place. Make sure that the front unit is completely closed by pushing until you hear a click.

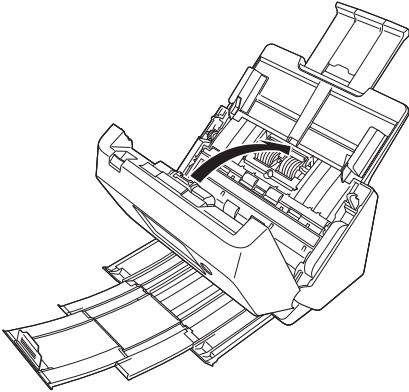

After removing the jammed paper, check to see if the last page was scanned correctly, and then continue scanning.



Hint

When the [Rapid recovery system] check box is enabled in the scanner driver settings screen, you can resume a scanning operation even if it is interrupted by a paper jam by removing the document and resuming from the document that was being fed when the interruption occurred.

As the image of the document that was being fed at the time of the interruption may not be saved in such cases, be sure to verify the last scanned image before resuming the operation.

Error Message

If one of the following messages appears on the touch panel, then an error has occurred on the scanner. Handle the error according to the countermeasure procedure.

Error messages	Symptom	Countermeasure
Scanner cover is open.	Front unit is open.	Close the front unit.
An invalid value has been set. Please try again.	An invalid character was input when the IP address was set manually.	Input a valid IP address.
Connection failed. Set it again.	Failed to connect to Wi-Fi when switching the connection mode.	Refer to "Q3. Scanner is not recognized." in Troubleshooting, and check the status of the Wi-Fi connection.
	Wi-Fi settings were done, but connections failed.	Refer to the Setup Guide, and check the Wi-Fi settings.
The connection has timed out. Please try again.	Timeout occurred because you forgot to press the router button, when doing the WPS (Wi-Fi Protected Setup) settings.	Redo the connection operations from the beginning.
To maintain maximum performance, the current rollers should be replaced now. Please refer to the instructions in the User Manual.	The number of scanned pages has exceeded 200,000, which exceeds the number of pages for the service life of the rollers.	Replace the rollers (See p. 90)
Paper jammed in scanner, clear paper and continue.	Paper jammed while scanning.	Open the front unit, and then remove the jammed document.
A double paper-feed has occurred. Please check the document and the scanned image on the display and scan the document again.	Paper double fed while scanning.	Open the front unit, and then remove the jammed document. Check the document, and then scan the document again.
No page was found in the feeder.	No document was loaded.	Load a document in the scanner's feeder.
Hardware error.	There is an internal scanner error.	Turn the power off and then on again. If the error appears even after turning the power off and then on again, make a note of the contents of the message, and then contact your service representative.

Uninstalling the Software

Some scanner malfunctions can be resolved by reinstalling the software. Before reinstalling the software, make sure to completely uninstall any previous installation first.

Uninstalling the TWAIN Driver

The following procedure uses the TWAIN driver as an example.



IMPORTANT

As always when uninstalling software, log on using an account with Administrator privileges.

- 1 From the Windows task bar, click Start button → click [Windows System] → click [Control Panel].

The Control Panel appears.

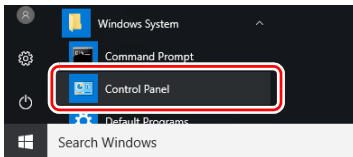

- 2 Click [Uninstall a program].

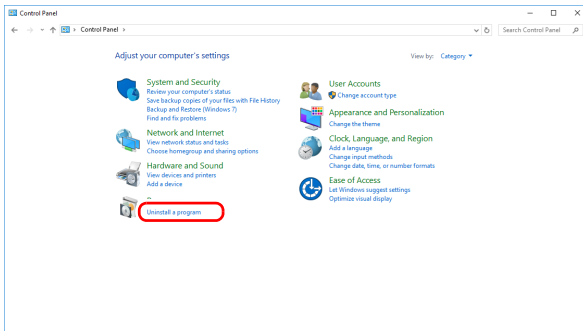

- 3 From the program list, select the application to be removed and click [Uninstall].

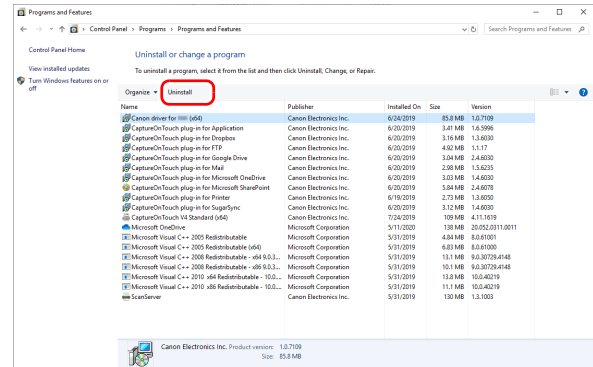

The file-deletion confirmation screen appears.

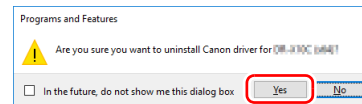

- 4 Click [Yes] to proceed with uninstallation.

Mac

No uninstaller is provided for macOS drivers. To uninstall, use Finder to delete the following files.
/Library/Image Capture/TWAIN Data Sources/R50.ds
/Applications/CaptureOnTouch

Specifications

Main Unit

Type	Desktop sheetfed scanner	Scanning resolution (Primary Scan Lines x Secondary Scan Lines)	100 x 100dpi/150 x 150dpi/200 x 200dpi/ 240x240dpi/300 x 300dpi/400 x 400dpi/600 x 600dpi
Scanning Document Size		Scanning Speed (Conditions: Core i7 2.8GHz CPU, 4 GB memory, A4 document size)	
Plain Paper		Grayscale	Simplex 200dpi 40 pages/min 300dpi 40 pages/min Duplex 200dpi 80 images/min 300dpi 80 images/min
Size:	Width: 50.8mm to 216 mm (2" to 8.5") Length: 54 mm to 356 mm (2.1" to 14") (You can scan documents up to 3,000 mm (118.1") long by setting the scanner to the Long Document mode.)	Color	Simplex 200dpi 40 pages/min 300dpi 30 pages/min Duplex 200dpi 80 images/min 300dpi 60 images/min
Paper weight:	27 to 209 g/m ² (7 to 56 lb bond) 0.04 mm to 0.25 mm (0.00157" to 0.00984")	Interface	USB 3.2 Gen1x1/ USB2.0 IEEE802.11b/g/n
Loading capacity:	A4 size or smaller: 60 sheets (80g/m ² (22 lb bond)) Larger than A4 size: 40 sheets (80g/m ² (22 lb bond)) Make sure stacks do not exceed 6 mm in height for either of the above.	Other functions	Double feed detection ignore
Business Card		External Dimensions	291 mm (11.5")(W) x 247 mm (9.8")(D) x 242 mm (9.5")(H) (With the document feed tray attached and the document eject tray closed) 291 mm (11.5")(W) x 600 mm (23.7")(D) x 378 mm (14.9")(H) (With the document feed tray attached and the document eject tray open)
Size:	50 mm x 85 mm (2" x 3.35") or larger	Weight (without AC adapter)	Approximately 3.3 kg (7.44 lb)
Paper thickness:	380 g/m ² (80 lb bond) 0.45 mm (0.0177") or smaller	Power Supply (using AC adapter)	DC24V 0.9A
Card		Power Consumption	Scanning: Maximum 22.5W or less In the Sleep mode: Maximum 3.1W or less (100-120V), Maximum 3.4W or less (220-240V) With power switch OFF: Maximum 0.1W or less
Size:	54 mm x 86 mm (2.12" x 3.37") (ISO standard)	Noise	Not more than 66 dB
Card thickness:	1.4 mm (0.055") or smaller	Operating Environment	Temperature: 10°C to 32.5°C (50°F to 90.5°F) Humidity: 20% to 80% RH
Orientation:	Horizontal feeding only		
Embossed cards can be scanned.			
Loading capacity:	3 cards (non-embossed), 1 card (embossed)		
Scanning Sensor	Contact image sensor		
Light source	LED		
Scanning Side	Simplex/duplex		
Scanning modes	Black and White, Error Diffusion, Grayscale, Advanced Text Enhancement, Advanced Text Enhancement II, Active Threshold, Color		

AC Adapter (100 to 240 V type)

Model Number	MG1-5039 (24V)
Input	AC100 to 240V, 50/60 Hz, 1.06 to 0.6 A
Output	DC24V 2.0A
Weight	Approximately 0.3kg (0.66 lb)

Specifications are subject to change without notice due to product improvements.

Replacement parts

Exchange roller kit (product code: 0697C003)

Kit to replace the rollers (feed roller, retard roller).

- For the replacement procedure, see [“Replacing Consumable Parts” on p. 90.](#)
- Contact your local authorized Canon dealer or service representative for detailed information about the replacement parts.

Dimensions

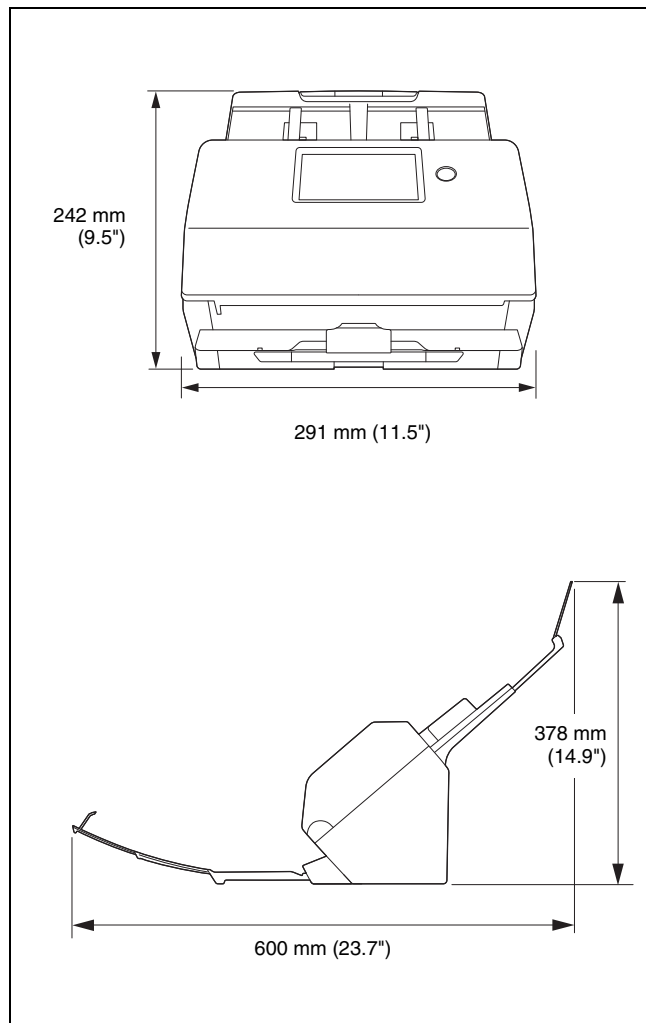



CANON ELECTRONICS INC.

3-5-10 SHIBAKOEN, MINATO-KU, TOKYO 105-0011, JAPAN

CANON U.S.A. INC.

ONE CANON PARK, MELVILLE, NY 11747, U.S.A.

CANON CANADA INC.

8000 Mississauga Road Brampton, Ontario L6Y 5Z7, CANADA

CANON EUROPA N.V.

BOVENKERKERWEG 59, 1185 XB AMSTELVEEN, THE NETHERLANDS

CANON AUSTRALIA PTY. LTD.

BUILDING A, THE PARK ESTATE, 5 TALAVERA ROAD, MACQUARIE PARK, NSW 2113, AUSTRALIA

CANON SINGAPORE PTE. LTD.

1 FUSIONOPOLIS PLACE, #15-10, GALAXIS, SINGAPORE 138522

CANON KOREA BUSINESS SOLUTIONS INC.

BS TOWER, 607 TEHERAN-RO, GANGNAM-GU, SEOUL, KOREA

CANON INDIA PVT. LTD

7TH FLOOR, TOWER B DLF CYBER TERRACES DLF PHASE III GURGAON - 122002 HARYANA, INDIA

PUB. 6T3-0020-E1.00

© CANON ELECTRONICS INC. 2020