



CONTAX TVS

Instruction manual • Bedienungsanleitung
Mode d'emploi • Manual de instrucciones

Thank you for your purchase of a Contax Tvs. Based on the Contax philosophy of producing a "camera which works," this 35mm lens-shutter camera is extremely simple to use.

It features a newly designed zoom lens, an electronically controlled focusing system, and an exposure control system consisting of aperture-priority auto exposure plus programmed auto exposure.

Before using the camera, be sure to read this instruction manual carefully to use it correctly.

Vielen Dank, daß Sie sich für eine Contax Tvs entschieden haben. Damit besitzen Sie eine Kompaktkamera, die in Verarbeitung und technischer Ausstattung einen Spitzenplatz einnimmt und höchsten Ansprüchen genügt. Um mit allen Eigenschaften dieser Camera vertraut zu werden, sollten Sie vor der ersten Inbetriebnahme unbedingt die Bedienungsanleitung sorgfältig lesen.

Contents

Names of Parts and their Functions	8	Bulb Exposure	100
Display in the Viewfinder.....	14	Taking Panoramic Format Pictures.....	102
Display Panel	23	Special Functions.....	114
Basic Procedures for		Camera Strap and Soft Case	
Taking Pictures	28	(Included Accessories)	124
Loading the Battery.....	28	Contax Tvs Data Back	
Battery Check/Battery Replacement	32	(Optional Accessory)	126
Loading the Film	36	Dedicated Accessories (Optional).....	138
Turning on the Main Switch (Knob).....	40	Camera Care and Precautions	142
Setting the Focusing Dial.....	42	Camera Storage.....	143
Setting the Aperture	44	Specifications.....	148
Choosing the Composition (Zooming)	54		
Taking Pictures	58		
Rewinding the Film.....	66		
Shooting Techniques	68		
Focus Lock	68		
AE Lock	72		
Exposure Compensation.....	74		
Flash Photography	80		
Shooting with the Self-timer	96		

Names of Parts and their Functions

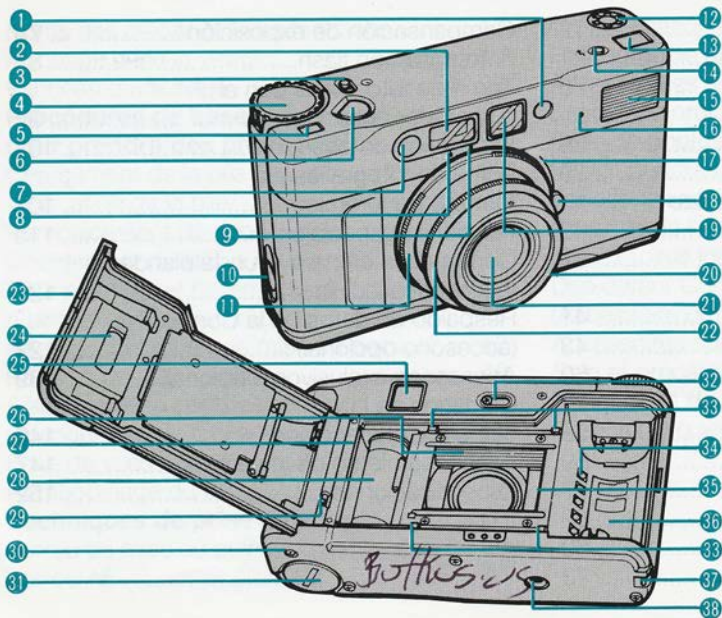

- 1 **Light Sensor**
- 2 **Focusing Window**
- 3 **Self-timer Switch**
- 4 **Focusing Dial:** The focusing mode is switchable on the dial as follows:
Automatic focusing
"AF" mark
Manual focusing
Distance scale (0.5m – ∞)
- 5 **Exposure Counter**
- 6 **Shutter Release Button**
- 7 **AF-assist Beam Emitter**
- 8 **Aperture Value Index (orange):** Indicates the approximate aperture at the focal length of 56mm when the aperture ring of the lens is set to F3.5 so that it comes opposite to the aperture index (black).
- 12
- 13
- 14
- 15
- 16
- 17
- 18
- 19
- 20
- 21
- 22
- 23
- 24
- 25
- 26
- 27
- 28
- 29
- 30
- 31
- 32
- 33
- 34
- 35
- 36
- 37
- 38

- 9 **Aperture Index (black):** Set your desired aperture on the aperture ring to this mark.
- 10 **Camera Back Release Knob**
- 11 **Aperture Ring:** The aperture ring is used for setting the aperture and the programmed exposure mode.
- 12 **Exposure Compensation Dial:** Exposure compensation up to ± 5 EV can be set in 1/3-EV steps.
- 13 **Display Panel:** The flash mode, exposure compensation value, and battery check mark are displayed on it.
- 14 **Flash Mode Button:** Used for switching the flash mode.
- 15 **Flash**
- 16 **Self-timer LED:** Blinks while the self-timer is operating.
- 17 **Zoom Mark:** When the main switch (knob) is within this range, the camera is turned on and ready for shooting.
- 18 **Main Switch (Knob):** Turns on and off the camera power.
- 19 **Viewfinder**
- 20 **Lens Front Ring:** The lens cap, filters (optional accessories), and lens hood (optional accessory) are attached to it.
- 21 **Lens**
- 22 **Zoom Ring:** Change the focal length of the lens by turning this ring (zooming). The main switch (knob) moves at the same time.
- 23 **Camera Back**
- 24 **Film Check Window:** It allows you to see if there is film in the camera or not.
- 25 **Viewfinder Eyepiece**
- 26 **Panoramic Mask**
- 27 **Film Tip Mark**
- 28 **Spool**
- 29 **Camera Back Release Pin**
- 30 **Manual Rewind Button:** Use this button if you want to rewind the film in the middle of a roll.
- 31 **Battery Compartment/Cover**
- 32 **Panoramic Mode Switch**
- 33 **Film Guides**
- 34 **DX Contact**
- 35 **Picture Area Frame**
- 36 **Film Chamber**
- 37 **Strap Lug**
- 38 **Tripod Socket**

Display in the Viewfinder

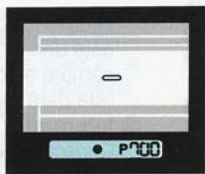
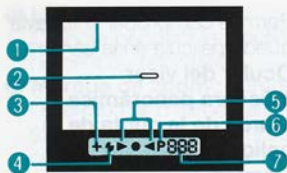

When taking panoramic format pictures (Panoramic mode)
 Bei Aufnahmen im Panoramaformat
 (bei Wahl der Panoramafunktion)
 Lors de prise de vues au format panoramique (mode panoramique)
 Cuando se toman fotografías en el formato panorámico (Modo panorámico)



Wide-angle: Close-ups
 (1m – 0.5m)
 Weitwinkel: Nahaufnahmen
 (1 m bis 0,5 m)
 Grand angle : Vues rapprochées
 (1 m – 0,5 m)
 Gran angular: Primeros planos
 (1 m – 0,5 m)



Telephoto: Close-ups
 (1m – 0.5m)
 Tele: Nahaufnahmen
 (1 m bis 0,5 m)
 Téléobjectif : Vues rapprochées
 (1 m – 0,5 m)
 Telefoto: Primeros planos
 (1 m – 0,5 m)



Wide-angle: Close-ups
 (1m – 0.5m)
 Weitwinkel: Nahaufnahmen
 (1 m bis 0,5 m)
 Grand angle : Vues rapprochées
 (1 m – 0,5 m)
 Gran angular: Primeros planos
 (1 m – 0,5 m)



Telephoto: Close-ups
 (1m – 0.5m)
 Tele: Nahaufnahmen
 (1 m bis 0,5 m)
 Téléobjectif : Vues rapprochées
 (1 m – 0,5 m)
 Telefoto: Primeros planos
 (1 m – 0,5 m)

(This illustration shows all information available in the viewfinder for reference. It does not represent an actual example of display.)

1 Picture Area Frame: When the shutter release is depressed halfway, the picture area frame on display changes automatically according to the shooting distance, lens focal length, etc.

To shoot, place your subject within the displayed frame.

- When shooting in the auto-focus mode, the picture area frame for taking close-ups is displayed while the shutter release is depressed halfway and for about 2 seconds after you remove your finger. In the manual-focus mode, it is displayed when the distance is set.
- When taking pictures in the panoramic mode, the panoramic format frame is displayed.

2 Focusing Frame: Place your subject to focus in this frame.

3 Exposure Compensation Mark: When exposure is compensated, "+" or "-" is displayed according to the type of compensation.

4 Flash Mark: Turns on when the picture is to be taken with flash. It blinks while the flash is charging, and turns on with steady light when the flash is fully charged.

5 Focusing Indicator: Shows the focusing mode.

6 Programmed Mode Indicator: Turns on when the aperture ring is set to "P" (program AE), or when the aperture is automatically stopped down and the exposure mode is switched to program AE.

7 Shutter Speeds: The camera displays the shutter speed in a range of 700 (1/700 second) to 16 (16 seconds).

- Shutter speeds are displayed in 1/2-step increments.
- If "P700" or "500" blinks, it means that your subject will be overexposed. If "16" blinks, it means that an exposure for more than 16 seconds is required to obtain correct exposure. In this case, if you keep on depressing the shutter release, the camera switches to the bulb exposure mode.
- The above items of **3** "Exposure Compensation Mark" to **7** "Shutter Speeds" are displayed when

the camera is operated as described in 1 and 2 below. They are displayed for 8 seconds, then automatically turn off to save the battery.

1. When the main switch (knob) is turned on.
2. With the main switch on, when the shutter release, zoom ring, focusing dial, or flash mode button is operated.

While the shutter is opened (the film is being exposed), the display turns off. In the case of long exposure, take particular care to prevent camera shake while the display turns off.

ⓑ OFF Mark: This mark appears when the main switch (knob) is set to “.” (OFF).

<Note on the Display in the Viewfinder>

This camera automatically displays the liquid crystal mask in the panoramic or close-up mode.

When you take pictures, keep the following points in mind:

- ① The picture area frame is the inner frame of the mask which is displayed. The fine line inside the mask is not within the picture area frame.

② If you are taking pictures in hot temperature or looking into the viewfinder at certain angles, the mask or “OFF” mark may appear very lightly when there is no item to be displayed. This is an intrinsic characteristic of the liquid crystal and does not mean anything is wrong.

③ The mask switches to display the needed frame when you switch the camera to the panoramic or close-up mode. But the display may differ from the setting depending on the operating procedure. In this case, you can reset the normal display by depressing the shutter release button halfway.

Example of display (panoramic mode)

This line is not within the picture-area frame.

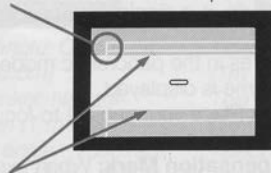

The picture area frame (The area inside this frame appears on the picture)

Display Panel

(This illustration shows all information available in the display panel for reference. It does not represent an actual example of display.)



1 Flash Mode Display: Shows the modes of the built-in flash.

Flash-auto mode ⚡ AUTO

Red-eye reducing pre-flash mode ⚡⚡ AUTO

Flash-off mode ⚡ OFF

Fill-in flash mode ⚡

2 Exposure Compensation Value: It does not appear when no compensation is made.

3 Battery Warning Mark: Turns on when it is time to change the battery.

<Exposure Counter>

(This illustration shows information available in the exposure counter for reference. It does not represent an actual example of display.)



The exposure counter shows the number of exposures. It also shows the lens focal length (when the shutter release is depressed halfway), remaining time on self-timer, and the time that has passed during bulb exposure.



This manual is for reference and historical purposes, all rights reserved.

This page is copyright© by M. Butkus, NJ.

This page may not be sold or distributed without the expressed permission of the producer
I have no connection with any camera company

On-line camera manual library

This is the full text and images from the manual. This may take 3 full minutes for the PDF file to download.

If you find this manual useful, how about a donation of \$3 to: M. Butkus, 29 Lake Ave., High Bridge, NJ 08829-1701 and send your e-mail address so I can thank you. Most other places would charge you \$7.50 for a electronic copy or \$18.00 for a hard to read Xerox copy.

This will allow me to continue to buy new manuals and pay their shipping costs.

It'll make you feel better, won't it?

**If you use Pay Pal or wish to use your credit card,
click on the secure site on my main page.**

PayPal Name Lynn@butkus.org

Venmo @mike-butkus-camera Ph. 2083

www.PayPal.me/lynnbutkus

<Lens Cap>

The accessory lens cap (K-31) can be put on the lens front frame and removed from it while pushing the left and right knobs inward.

- Be sure to remove the lens cap when taking pictures. Caution is required because the shutter trips with the lens cap attached.
- After shooting, be sure to put on the lens cap to protect the lens.

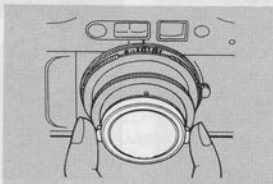

<Objektivdeckel>

Zum Anbringen und Entfernen des mitgelieferten Objektivdeckels (K-31) am bzw. von Objektivfrontring die beiden Knöpfe links und rechts nach innen drücken.

- Vor dem Aufnehmen nicht vergessen, den Objektivdeckel abzunehmen.

Vorsicht ist geboten, da der Verschluss auch bei angesetztem Objektivdeckel ausgelöst wird.

- Nach dem Aufnehmen den Objektivdeckel wieder anbringen, um das Objektiv zu schützen.

<Capuchon d'objectif>

Le capuchon d'objectif accessoire (K-31) peut être placé sur le cadre avant de l'objectif et retiré en poussant les boutons droit et gauche vers l'intérieur.

- Retirez toujours le capuchon d'objectif pour prendre des photos. Faites attention car l'obturateur peut être déclenché avec le capuchon d'objectif en place.

- Après la prise de vues, remettez toujours le capuchon d'objectif pour protéger l'objectif.

<Tapa del objetivo>

La tapa del objetivo accesoria (K-31) puede ponerse en el marco frontal del objetivo y se saca presionando las lengüetas izquierda y derecha.

- Asegúrese de extraer la tapa del objetivo antes de fotografiar. Hay que tener cuidado porque el obturador se dispara con la tapa del objetivo puesta.

- Después de fotografiar, asegúrese de poner la tapa del objetivo para protegerlo.

Basic Procedures for Taking Pictures

Aufnahme- vorbereitungen

Procédures de base pour prendre des photos

Procedimientos básicos para tomar fotografías

Loading the Battery

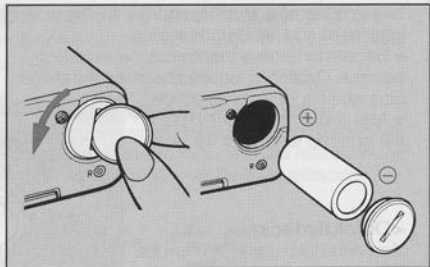

1 Open the battery compartment cover by turning it with a coin in the direction of the arrow.

2 Load the battery in the battery compartment with the plus (+) and minus (-) ends correctly as illustrated in the compartment, then replace the cover.

- Use one 3V lithium battery (CR123A or DL123A).

If the flash mark “⚡” turns on in the display panel and the battery warning mark “🔋” does not appear when the camera's main switch (knob) is set to “ON” as shown, the battery is correctly loaded.

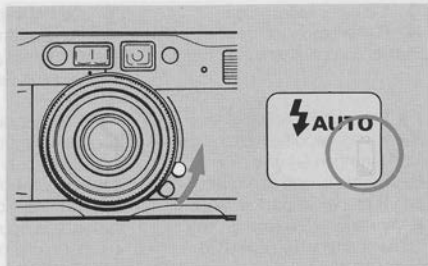

- 1 Open the battery compartment cover by sliding it with a coin in the direction of the arrow.
 - 2 Load the battery in the battery compartment with the plus (+) and minus (-) ends correctly as illustrated in the compartment; then replace the cover.
- * Use one 3V lithium battery (CR123A or DL123A).

Battery Check/Battery Replacement



If the battery warning mark () does not turn on in the display panel, the battery has a sufficient voltage.

<Battery Replacement>

If the mark "  " turns on in the display panel, it is time to change the battery. Turn off the main switch, open the battery compartment cover and change the battery with a new one.

- Even if the mark "  " turns on, you can still take pictures for a while. But it is recommended to replace the battery as soon as possible. If the battery capacity falls below the specified limit, the display in the display panel turns off and the camera no longer operates.

<Battery Precautions>

- Generally, the battery performance is temporarily reduced by low temperature. If you are taking pictures in cold weather, keep the camera warm by putting it inside your jacket and taking it out only when it is needed. The battery performance reduced by low temperature returns to normal at an ordinary temperature.
- If the (+) and (-) poles of the battery are soiled with sweat or grease, poor contact will result. Wipe both poles clean with a dry cloth before use.
- If you are going on a long trip, bring a spare new battery with you.
- Never put the battery in fire and do not recharge, short, disassemble or heat it because it is dangerous.
- The camera does not operate if the battery is loaded with "+" and "-" ends wrong.
- The 3V lithium battery (CR123A or DL123A) cannot be recharged.
- Keep the battery out of reach of children.

Loading the Film

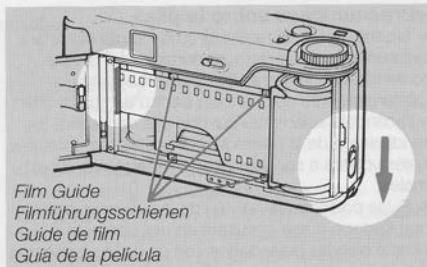

1 Open the camera back by pushing down the camera back release knob in the direction of the arrow.

2 Load DX-coded film and set the film tip to the mark "—".
The film cassette is inserted slantwise in the film chamber.

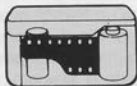

The film tip should be pulled out as far as the orange "—" mark and placed on the spool. Place the film inside the upper and lower film guides and take care that it does not float up.

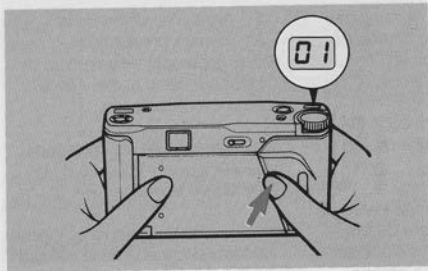

3 Close the camera back securely. As soon as the camera back is closed, the film advances automatically and stops when the exposure counter shows "01".

- If the exposure counter blinks at "00", the film is not advancing properly. Open the camera back and reload the film.

- If you are using DX-coded film, the camera automatically sets its film speed. If you are using non-DX-coded film, the film speed is automatically set to ISO 100.
- Take care not to touch or soil the DX contacts.
- Always load and unload film in subdued light.
- When loading film, be sure to remove the protective sheet in the camera's picture area frame.

*Protective Sheet
Schutzfolie
Feuille de protection
Una lámina protectora*

フィルムを挿入するときは、必ずこのシートを取りはずしてください。

Before the film insertion, please remove this sheet.

Turning on the Main Switch (Knob)

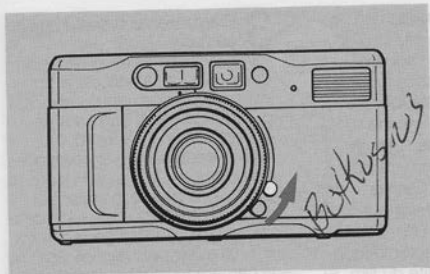

Move the main switch (knob) from “.” to “)” (zoom mark) in the direction of the arrow (see illustration). The camera is now turned on and ready for shooting.

- If you are not taking pictures immediately, return the main switch to “.” (OFF) to prevent tripping the shutter inadvertently.

- When the main switch is reset to “.”, the lens is retracted at the same time.

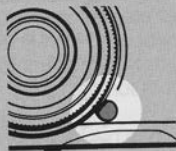

Main Switch (Knob) at OFF

Hauptschalter (Knopf) ausgeschaltet

Interrupteur d'alimentation (bouton) sur OFF

Interruptor principal (perilla) en OFF.

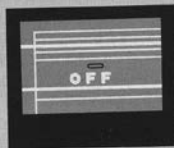

Display in the viewfinder with the main switch at OFF.

Suchanzeige bei ausgeschaltetem Hauptschalter

Affichage dans le viseur avec l'interrupteur d'alimentation sur OFF

Visualización del visor con el interruptor principal en OFF.

Also, “OFF” is displayed in the viewfinder.

Setting the Focusing Dial

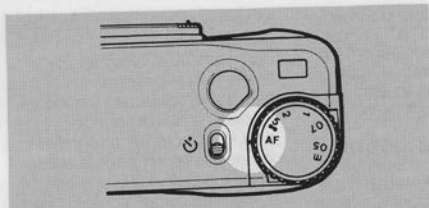

*Auto Focusing/Manuelle Fokussierung
Mise au point automatique/Enfoque automático*

Set the focusing dial to the "AF" mark or within the "Manual Focus Range."

Auto focusing: "AF" mark

Manual focusing: Manual Focus Range

"∞ – 0.5" (m) on the scale

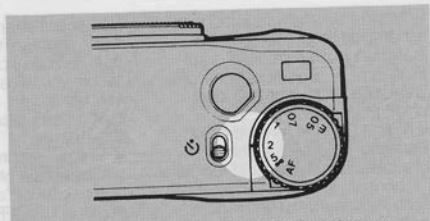

*Manual Focusing/Automatische Fokussierung
Mise au point manuelle/Enfoque manual*

- For ordinary shooting, it is convenient to set the focusing dial to "AF" because focusing is done automatically by the camera.
- Use the manual focusing if you change the composition after focusing is done, or if you set the distance by visual estimation.

Setting the Aperture

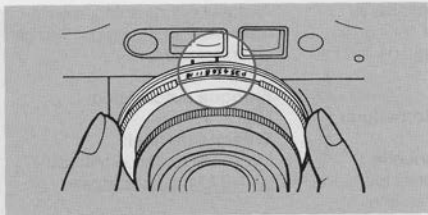

To control the exposure, the Contax Tvs provides an aperture-priority AE mode in which the camera automatically selects the correct shutter speed according to the aperture you have set and, in addition, an aperture priority program AE which offers a function of programmed exposure added to the aperture-priority AE.

Turn the aperture ring of the lens and bring the number "5.6" (green) opposite to the aperture index (black). Now, the camera is set for aperture-priority AE with the aperture at 5.6. For ordinary shooting, it is recommended to set the aperture to F5.6.

◎ If you set your desired aperture number to the aperture index (black), the camera sets itself for **aperture-priority AE**. In the viewfinder, you will see the shutter speed selected by the camera according to the aperture you have set.

● If the aperture is set to F3.5 – 4 when the lens focal length is 28mm, caution is required because the quantity of light will be reduced on picture edges. It is recommended, therefore, to shoot with the aperture at F5.6 (green) or smaller.

◎ If you set the letter "P" to the aperture index (black), the camera sets itself for **program AE**.

In the viewfinder, you will see the letter "P" and the shutter speed being set.

- When the aperture ring is set at "P", it is recommended to shoot with lens focal length at 35mm or longer because an aperture of F3.5 will be required if the light is dim.

.....

- If the subject is so bright that the camera cannot provide correct exposure within its shutter speed range when it is set to aperture-priority AE, it automatically switches to program AE and selects a proper aperture and shutter speed that provide correct exposure. In this case, the fastest shutter speed which can be set by the camera is 1/700 sec. When it is set to program AE, "P" is displayed in the viewfinder.

If the aperture ring is set to F16, the camera does not switch to program AE and the shut-

ter that can be set by it is 1/500 sec. or slower.

- If the shutter speed in the viewfinder blinks at "P700", your subject will be overexposed because it is beyond the camera's exposure coupling range. If the shutter speed blinks at "500" when the aperture is set to F16, it will be overexposed.

- If "16" blinks, it means underexposure. If you keep on depressing the shutter release, the camera switches to bulb exposure after 16 seconds. (For details, refer to "Bulb exposure" on page 100.)

- This camera is designed to fire its built-in flash automatically in dim light when the flash mode has been set to automatic flash activation ("  AUTO "). (For details on flash photography, refer to page 82.)

● The aperture values change with the focal length. The aperture value index (orange) indicates an approximate aperture at the focal length of 56mm when the aperture ring is set to F3.5. If the aperture is stopped down to F4 or smaller, the actual aperture is approximately 2 stops smaller. The camera's metering function, however, operates properly in accordance with the change of the aperture by zooming.

In the program AE and aperture-priority AE modes, the metering range and shutter speeds corresponding to each aperture change as shown in this diagram.

Exposure Control Diagram (f=28mm)

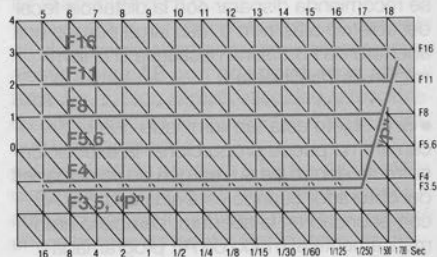

"P": Program AE

"P": Programmautomatik

"P": Exposition automatique (AE) programmée

"P": Exposición automática (AE) programada

Choosing the Composition (Zooming)

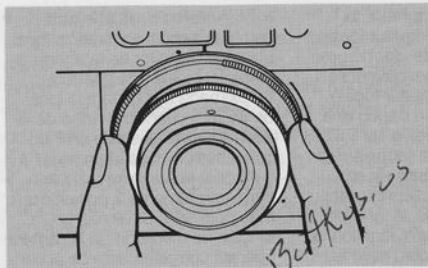

While looking at the subject through the viewfinder, choose the subject size by turning the zoom ring (zooming).

Check the position of the panoramic mode switch. If it is set as shown in the illustration, the camera is in the panoramic mode and the picture you take is a horizontally long panoramic format picture with the top and bottom portions of the standard-format pictures being cut. In the panoramic mode, the picture area frame in the viewfinder changes accordingly.



- As the lens moves, the field of view in the viewfinder changes accordingly.
- **Zoom the lens with the zoom ring.** If you zoom with the main switch (knob), caution is required because the flash reflector may be blocked with your finger when the lens is set to telephoto.
- The lens focal length can be confirmed on the exposure counter. If you depress the shutter release button halfway, the exposure counter switches to show the focal length while the shutter release button is held depressed.
The focal length on display is available only as a guide.



- Beim Zoomen des Objektivs ändert sich das Bildfeld im Sucher entsprechend.
- **Zoomen Sie des Objektiv mit dem Zoomring.** Beim Zoomen mit dem Hauptschalter (knopf) ist Vorsicht geboten, da der Blitzreflektor bei Einstellung des Objektivs auf Telefoto u.U. durch einen Finger verdeckt wird.
- Die Brennweite kann im Bildzählwerk kontrolliert werden. Das Bildzählwerk schaltet auf die Anzeige der Brennweite um, solange der Auslöser leicht eingedrückt wird. Bei der Anzeige der Brennweite handelt es sich lediglich um einen Näherungswert.

Taking Pictures

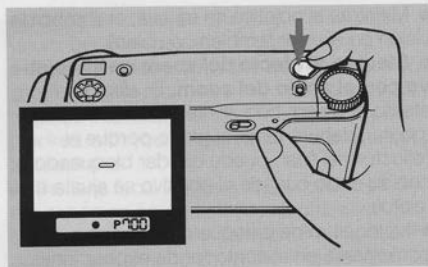

■ When the focusing dial is set to "AF" (auto-focus)

1 Aim the focusing frame at the subject you want to focus, and depress the shutter release halfway.

The lens focuses itself automatically and the mark "•" in the focus display turns on.



*Wide-angle: Close-ups
(1 m – 0.5 m)*

*Weitwinkel: Nahaufnahmen
(1 m bis 0,5 m)*

*Grand angle : Vues rapprochées
(1 m – 0,5 m)*

*Gran angular: Primeros planos
(1 m – 0,5 m)*



*Telephoto: Close-ups
(1 m – 0.5 m)*

*Tele: Nahaufnahmen
(1 m bis 0,5 m)*

*Téléobjectif : Vues rapprochées
(1 m – 0,5 m)*

*Telefoto: Primeros planos
(1 m – 0,5 m)*

2 If you depress the shutter release button all the way, the shutter trips to take your picture.

Shooting Distance: 0.5 m – ∞

- When the shutter release button is depressed halfway, the picture area frame in the viewfinder changes according to the shooting distance and lens focal length. To shoot, place your subject within the displayed frame.
- If the mark "▶" blinks, the shutter does not trip because your subject is too close to the camera. Take your picture at a distance of 0.5m or more.
- If the camera-to-subject distance is 0.3m or smaller, the mark "●" may turn on but the subject is not in sharp focus.
- When the mark "▶ ◀" blinks, the subject cannot be focused by the camera's auto-focus system and the shutter does not trip. Use the focus lock, turn on the mark "●" and shoot.
- If it is difficult to focus because the subject is dimly lighted or its contrast is low, the AF-assist beam is automatically emitted on the subject to increase the accuracy of the auto-focus system.



- Wenn Sie leicht auf den Auslöser drücken, ändert sich der Bildrahmen im Sucher entsprechend der Aufnahmeentfernung und Brennweite. Achten Sie darauf, daß das Motiv innerhalb des Rahmens liegt.
- Blinkt das Signal "▶", und läßt sich die Camera nicht auslösen, sind Sie zu nahe am Motiv. Vergrößern Sie die Aufnahmeentfernung auf mindestens 0,5 m.
- Bei einer Motiventfernung von 0,3 m oder weniger leuchtet zwar das Signal "●", das Motiv wird jedoch u.U. nicht scharf abgebildet.
- Wenn das Signal "▶ ◀" blinkt, ist keine automatische Fokussierung möglich, und der Verschuß löst nicht aus. Verwenden Sie den Schärfespeicher, so daß das Signal "●" aufleuchtet, um die Aufnahme zu machen.
- Falls ein schwach beleuchtetes oder kontrastarmes Motiv die automatische Fokussierung erschwert, wird das AF-Hilfslicht automatisch auf das Motiv projiziert, um die Funktion des Autofocus-Systems zu unterstützen.

■ When the focusing dial is set within the manual-focus range

(∞ – 0.5 (m))

1 Aim the focusing frame at the subject you want to focus and operate the focusing dial while looking at the subject through the viewfinder.

- The picture area frame in the viewfinder changes according to the shooting distance set with the focusing dial and the lens focal distance. Place your subject within the displayed frame.

2 Depress the shutter release all the way. The shutter trips to take your picture.

Shooting Distance: 0.5m – ∞

- The AF-assist beam is not emitted in the manual-focus mode.

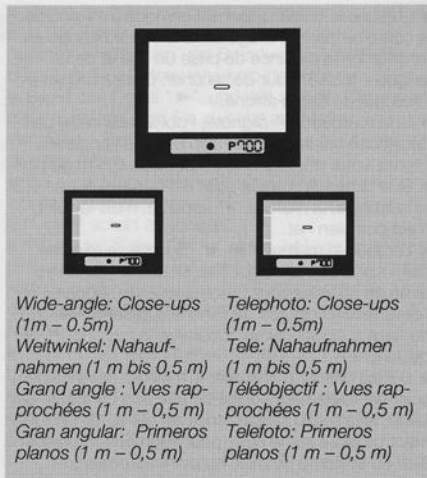

Focusing Indicators

“◀” mark (turns on) ... The lens is focused on a point nearer than the subject in the focusing frame (front focus).

“●” mark (turns on) ... The lens is focused on the subject in the focusing frame (sharp focus)

“▶” mark (turns on) ... The lens is focused on a point farther than the subject in the viewfinder (rear focus).

“▶ ◀” mark (blinks) ... The subject cannot be correctly focused because it is impossible to measure its distance.

Fokus-Signal

“◀” Symbol (leuchtet) ... Entfernung auf einen Punkt vor dem Motiv eingestellt (Fokussierung zu nah)

“●” Symbol (leuchtet) ... Entfernung exakt auf das Motiv eingestellt (Fokussierung richtig)

“▶” Symbol (leuchtet) ... Entfernung auf einen Punkt hinter dem Motiv eingestellt (Fokussierung zu weit)

“▶ ◀” Symbol (blinkt) ... Motiv wird nicht scharf abgebildet, da Entfernungsmessung unmöglich.

Rewinding the Film

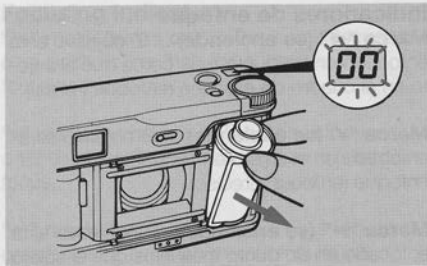

As soon as the entire roll of film is exposed, the camera rewinds the film automatically.

While the film is rewinding, the exposure counter counts down. When rewinding is completed, the motor stops and the number "00" in the counter blinks.

After the film is rewound, open the camera back and take out the film.

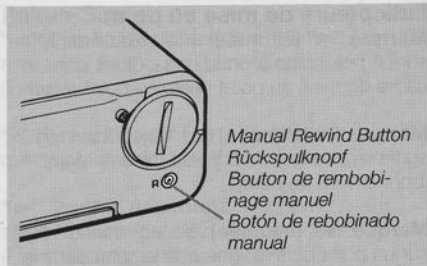

- The camera does not operate unless the camera back is once opened.
- To rewind the film in the middle of a roll, press the manual rewind button on the camera bottom with a fine-pointed object. (Do not press it with a sharp-pointed object such as a needle.)
- Take the exposed film for processing as soon as possible.

Shooting Techniques

Weitere Camerafunktionen

Techniques de prise de vues

Técnicas de fotografía

Focus Lock

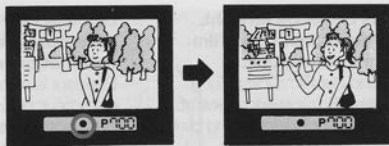

If the subject you want to focus is not in the focusing frame when shooting in the auto-focus mode, use the focus lock

- ① Aim the focusing frame at the subject you want to focus, and depress the shutter release button halfway. The lens is focused on the subject and the mark "●" turns on (the focus lock button is activated).
 - ② While the shutter release button is depressed halfway, move the camera to recompose the picture and take it by depressing the shutter release button all the way.
- Because the focus remains locked as long as the shutter release button is depressed halfway, your subject is in sharp focus even if you move the camera.
 - The focus lock is released if you remove your finger from the shutter release button.

- When the shutter release button is depressed halfway, the focus is locked and the exposure is fixed at the same time (AE lock).
- In the following cases, the lens may not be able to focus itself properly on the subject. In such cases, focus the lens on another object located at the same distance as the subject, lock the focus with the focus lock and shoot.
 1. When the subject is very bright or very dark.
 2. When the contrast between the subject and its background is extremely low.
 3. When there is a strong light source such as sunlight in the focusing frame or around.
 4. When there are two or more subjects you want to take at an extremely different distance in the focusing frame.
 5. When the subject has vertical lines alone or a repeated pattern of vertical lines.
 6. Fast moving objects.
 7. When the subject has no concrete shape such as flame or smoke.
 8. Extremely small objects.
- Wenn Sie den Finger vom Auslöser nehmen, wird die Speicherung gelöscht.
- Bei leichtem Druck auf den Auslöser wird gleichzeitig die Entfernung und der Belichtungswert gespeichert (AE Lock).
- Folgende Objekte sind nicht oder nur schwierig zu fokussieren. Wählen Sie in solchen Fällen ein "Ersatzmotiv" in gleicher Entfernung und verwenden Sie den Schärfespeicher.
 1. Bei sehr hellen oder sehr dunklen Motiven.
 2. Bei sehr schwachem Kontrast zwischen Motiv und Hintergrund.
 3. Bei starken Lichtquellen, z. B. Sonne, in oder nahe dem AF-Meßfeld.
 4. Wenn sich zwei oder mehrere Motive in sehr unterschiedlichem Abstand in der Fokuszone befinden.
 5. Motive mit senkrechten Linien oder einer aus senkrechten Linien bestehenden Struktur, z. B. ein Gartenzaun.
 6. Motive, die sich schnell bewegen.
 7. Körperlose Motive wie Flammen oder Rauch.
 8. Extrem kleine Motive.

The AE lock allows you to fix the exposure by depressing the shutter release button halfway.

If you want to set exposure on a subject which is not in the center of your picture frame, aim the camera at the subject, depress the shutter release button halfway to lock the exposure, then recompose your subject and trip the shutter. Thus, the subject is correctly exposed with the AE lock. The focus lock is activated simultaneously with the AE lock. If the subject you want to focus is not the same as that which you want to set exposure on, focus the lens manually and set exposure with the AE lock by depressing the shutter release button halfway. If you want to take pictures continuously with the exposure and focus locked, do not remove your finger from the shutter release button after tripping the shutter and hold the shutter release button depressed halfway. Then, trip the shutter again by depressing it all the way. To measure exposure each time, remove your finger from the shutter release button and depress it again.

Der Meßwertspeicher ermöglicht es, mit leichtem Druck auf den Auslöser den automatisch gewählten Belichtungswert zu speichern (AE-Lock).

Wenn Sie die Belichtung speziell auf ein Motiv abstimmen wollen, das nicht in der Bildmitte liegt, richten Sie die Camera auf das Motiv, drücken leicht auf den Auslöser, um die Belichtung zu speichern, wählen dann den gewünschten Bildausschnitt und drücken den Auslöser ganz durch, so wird das Motiv richtig belichtet.

Schärfespeicher und Meßwertspeicher sind immer gekoppelt. Wollen Sie Schärfe und Belichtung an verschiedenen Motivdetails orientieren, muß manuell fokussiert werden.

Wollen Sie mehrere Aufnahmen mit gleicher Belichtung machen, geben Sie nach der Auslösung den Auslöser nicht ganz frei, sondern halten ihn weiterhin leicht gedrückt. So bleibt der gespeicherte Belichtungswert erhalten.

Für eine neue Meßwertspeicherung den Auslöser freigeben und erneut leicht drücken.



No compensation
Keine Korrektur
Pas de compensation
Sin compensación

Compensation to the "+" side
Positiver Korrekturfaktor ("+")
Compensation sur le côté "+"
Compensación hacia el lado "+"

■ **For backlit subjects, compensate exposure in a range of "+0.3 ~ +5."**

If you are shooting a portrait in backlight, against a bright sky or sea, in front of a window, etc., where the greater part of your picture is occupied by a bright background, your subject will be underexposed and turn out dark like a silhouette. In such cases, compen-

sate exposure in a range of +0.3 ~ +5 EV to increase the exposure.



■ For stage scenes, compensate exposure in a range of “-0.3 ~ -5.”

If you are shooting a spotlighted subject on a stage where a dark backlight predominates in the scene, the main subject will be overexposed and turn out light. In this case, compensate exposure in a range of - 0.3 ~ - 5 EV to reduce the exposure.



No compensation
Keine Korrektur
Pas de compensation
Sin compensación





Compensation to the “-” side
Positiver Korrekturfaktor (“-“)
Compensation sur le côté “-“
Compensación hacia el lado “-“

<Exposure Compensation when Using a Filter>

If you are using a filter, compensate exposure by turning the exposure compensation dial according to the filter's compensating value (filter factor).

Flash Photography

Each time you press the flash mode button, the flash mode switches in the following order and is displayed in the display panel.

- 1 Flash-auto mode  →
- 2 Red-eye reducing pre-flash mode  →
- 3 Flash-off mode  →
- 4 Fill-in flash mode 

Set your desired mode in the display panel and shoot.

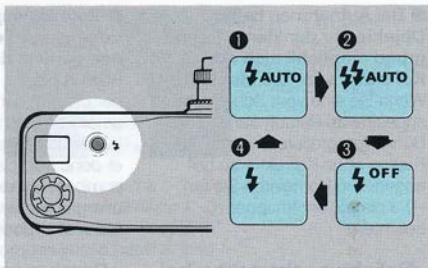

1 Flash-auto mode: “ ⚡ AUTO ”

If the subject is so dark that it requires a shutter speed slower than 1/60 sec., the flash is automatically activated to take your picture. The shutter speed is set to 1/60 sec.

- When the flash is activated, the mark “ ⚡ ” in the viewfinder turns on.

<Flash-auto mode in backlight>

If you are shooting in the flash-auto mode (⚡ AUTO) or red-eye reducing pre-flash mode (⚡⚡ AUTO), and the subject is in the center of the picture frame and backlighted, the flash may fire depending on the brightness of the subject so that it is beautifully exposed.

1 Blitzautomatik: “ ⚡ AUTO ”

Ist das Motiv so dunkel, daß es eine Verschlusszeit länger als 1/60 s benötigt, so wird der Blitz automatisch aktiviert. Die Verschlusszeit wird automatisch auf 1/60 s eingestellt.

- Bei Aktivierung des Blitzes leuchtet das Blitzsymbol “ ⚡ ” im Sucher.

<Blitzautomatik bei Gegenlicht>

Wenn sich das Motiv bei Blitzaufnahmen in der Funktion Blitzautomatik (⚡ AUTO) oder Anti-Rotauge-Blitz (⚡⚡ AUTO) in der Mitte des Leuchtrahmens befindet, wird der Blitz je nach Helligkeit des Motivs ausgelöst, um eine einwandfreie Belichtung zu gewährleisten.

2 Red-eye reducing (pre-flash) mode: “ AUTO”

If a person is photographed in dim light with flash, the pupils of his (or her) eyes, though rarely, may turn out red in the picture (red-eye effect). This pre-flash mode is useful for reducing this red-eye effect.

In this mode, the flash fires twice at an interval of approximately 0.8 sec.

After the flash fires for the first time, the self-timer

LED blinks until it fires for the second time. The shutter trips when it fires for the second time. Take care not to move the camera or that the subject does not move after the first firing of flash.

- The flash-firing condition is the same as that in the automatic flash activation mode. The flash automatically fires in dim light.

2 Anti-Rotaugen-Blitz: “ AUTO”

Bei Blitzaufnahmen von Personen in schwachem Umgebungslicht, die in Richtung Objektiv blicken, erscheinen die Pupillen im Foto oft rot. Dagegen hilft der Anti-Rotaugen-Blitz. In dieser Funktion wird 0,8 s vor der eigentlichen Blitzbelichtung ein Vorblitz gezündet, der ein Schließen der Pupillen bewirkt und so den gefürchteten “Rotaugen“-Effekt reduziert.

Nach Zündung des Vorblitzes blinkt die Selbstausröser-LED bis zur zweiten Blitzzündung, bei der der Verschluss ausgelöst wird. Achten Sie darauf, daß sich weder die Camera noch die aufzunehmende Person nach dem ersten Blitz (Vorblitz) bewegt.

- Die Blitzzündung erfolgt unter den gleichen Bedingungen wie bei Blitzautomatik, d.h. der Blitz wird bei wenig Licht automatisch gezündet.

3 Flash-off mode: "⚡ OFF"

If you want to take pictures without flash such as twilight scenes or indoor mood pictures, set the camera to this mode.

Because the exposure is determined in accordance with the brightness of the subject, the picture is taken in a natural mood.

- If a shutter speed slower than "60" (1/60 sec.) is displayed in the viewfinder, use a tripod to prevent camera shake.
- In the flash-off mode, the mark "⚡" is not displayed in the viewfinder.

4 Fill-in flash mode: "⚡"

Whether the subject is bright or dark, the flash always fires in this mode. It can be used if you want to use flash as fill-in light or take pictures with a slow-shutter synchronization.

3 Blitz Aus: "⚡ OFF"

Wählen Sie diese Funktion, um Aufnahmen ohne Blitz zu machen, z. B. Szenen in der Dämmerung oder stimmungsvolle Innenaufnahmen. Da die Belichtung in dieser Funktion in Abhängigkeit von der Helligkeit des Motivs erfolgt, entstehen natürlich wirkende Aufnahmen.

- Wenn eine längere Verschlusszeit als "60" (1/60 s) im Sucher angezeigt wird, sollte wegen Verwacklungsgefahr ein Stativ oder eine stabile Cameraunterlage verwendet werden.
- Bei ausgeschalteter Blitzfunktion erscheint das Blitzsymbol "⚡" nicht im Sucher.

4 Aufhellblitz: "⚡"

In dieser Funktion wird der Blitz stets gezündet, wobei es keine Rolle spielt, ob das Motiv hell oder dunkel ist. Diese Funktion eignet sich zum Gebrauch des Blitzes als Aufhellblitz und für Aufnahmen mit Blitzsynchronisation bei langer Verschlusszeit.

<Taking Pictures with Fill-in Flash>

Even if you are taking pictures in bright sunlight, you can use flash as fill-in light to obtain correct exposure of your backlighted subject. It is useful for shooting a subject which is in the shade of a tree or stands in front of a window. It can be used either in the program AE or aperture-priority AE mode.

<Taking Pictures with a Slow-shutter Synchronization>

If the subject is so far in a night scene that the flash light does not reach it, use the fill-in flash mode. Both the subject and its background will be beautifully exposed by using flash with a slow shutter speed. Caution is required, however, because the shutter speed is slow.

This mode can be used in the aperture-priority AE mode.

- When the exposure mode is set to "P" (programmed auto exposure), you cannot take pictures with a slow-shutter synchronization.

<Aufhellblitz>

Wenn sich das Motiv im Gegenlicht befindet, kann selbst bei Aufnahmen in strahlendem Sonnenschein mit Aufhellblitz gearbeitet werden, um eine korrekte Belichtung zu erzielen, z.B. wenn eine Person im Schatten eines Baumes oder vor einem Fenster steht. Diese Blitzfunktion steht sowohl bei Zeitautomatik nach Blendenvorwahl als auch bei Programmautomatik zur Verfügung.

<Blitzsynchronisation bei langer Verschußzeit>

Verwenden Sie die Funktion Blitz eingeschaltet, wenn sich das Motiv bei einer Nachtaufnahme in so großer Entfernung befindet, daß es vom Blitz nicht ausgeleuchtet werden kann. Die Blitzsynchronisation bei langer Verschußzeit sorgt dafür, daß sowohl Motiv als auch Hintergrund einwandfrei belichtet werden. Wegen der langen Verschußzeit ist in dieser Funktion jedoch Vorsicht geboten (Verwackelungsgefahr). Diese Blitzfunktion steht bei Zeitautomatik nach Blendenvorwahl zur Verfügung.

- Bei Programmautomatik ("P") sind keine Aufnahmen mit Blitzsynchronisation bei langer Verschußzeit möglich.

- The mark “⚡” in the viewfinder blinks while the flash is charging, and turns on with steady light when it is fully charged. Make sure that the flash is fully charged before you shoot.

(The mark “⚡” in the viewfinder is not displayed in the flash-off mode.)

- While the flash is charging, only the mark “⚡” blinks in the viewfinder and all other display elements such as shutter speeds turn off.

As soon as the flash is fully charged, the mark “⚡” turns on with steady light and all other display elements also turn on.



- You cannot trip the shutter while the flash is charging.
- Caution is required because the focus is locked if the shutter release is depressed halfway while the flash is charging.

- Das Blitzsymbol “⚡” im Sucher blinkt während des Ladevorgangs und leuchtet konstant bei Blitzbereitschaft.

(Bei ausgeschaltetem Blitz erscheint das Blitzsymbol “⚡” nicht im Sucher.)

- Während des Blitzladevorgangs blinkt nur das Blitzsymbol “⚡” im Sucher; alle anderen Anzeigen, z. B. die Verschlusszeit, sind nicht sichtbar.

Sobald der Blitz vollständig aufgeladen ist, leuchtet das Blitzsymbol “⚡” konstant, alle anderen Anzeigen erscheinen wieder im Sucher.

- Während des Blitzladevorgangs ist eine Auslösung nicht möglich.
- Während des Blitzladevorgangs ist Vorsicht geboten, da die Entfernungseinstellung bei leichtem Druck auf den Auslöser gespeichert wird.

© When you set your desired aperture (aperture-priority AE), the quantity of light of the flash changes with the shooting distance.

© When the exposure mode is set to "P" (program AE), the aperture changes with the shooting distance (flashmatic method).

● **When you take flash pictures, it is recommended to set the exposure mode to "P". If you stop down the aperture, the flash effective range becomes shorter.** If the mark "⚡" in the viewfinder blinks quickly, it warns you that your subject will be underexposed. You will have to adjust so that the mark "⚡" stops blinking. If you are using reversal film, the flash effective range will become still shorter. Take pictures within the ranges shown in the table below.

If you want to take pictures with flash at longer distances than the effective range of the built-in flash, use an external clip-on flash with the aid of the Contax Flash Adapter SA-1 (optional accessory).

© Wenn der Blendenring auf Zeitautomatik nach Blendenvorwahl eingestellt ist, wird die Lichtmenge des Blitzes entsprechend der Motiventfernung variiert, um die korrekte Belichtung zu erzielen.

© Bei Einstellung des Blendenrings auf "P" (Programmautomatik) erfolgt die Belichtungssteuerung beim Blitzen durch eine automatische Blendeneinstellung in Abhängigkeit von der Motiventfernung (Flashmatic-System).

● **Bei Blitzaufnahmen empfiehlt es sich, den Blendenring auf "P" (Programmautomatik) einzustellen. Wenn die Blende verringert wird, nimmt der Blitzbereich ab.** Das Symbol "⚡" blinkt in rascher Folge im Sucher, wenn Unterbelichtungsgefahr besteht. In einem solchen Fall muß die Einstellung geändert werden, so daß das Symbol "⚡" zu blinken aufhört. Bei Verwendung von Umkehrfilm wird der Blitzbereich noch kürzer. Machen Sie die Blitzaufnahmen innerhalb des in der Tabelle unten gezeigten Blitzbereichs. Um Blitzaufnahmen in einer Entfernung zu machen, die den Blitzbereich des eingebauten Blitzgerätes überschreitet, verwenden Sie ein externes aufsteckbares Blitzgerät und den Contax Blitzadapter SA-1 (Sonderzubehör).

Effective Ranges of the Built-in Flash

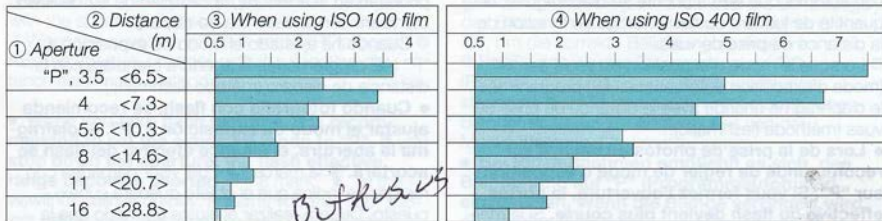

 : Flash effective range at 28mm

 : Flash effective range at 56mm

* The figures in parentheses show the actual aperture values at 56mm for the aperture values indicated on the aperture ring.

Shooting with the Self-timer

If you want to get into the picture yourself in a souvenir picture, use the self-timer.

- 1** Mount the camera on a tripod.
- 2** Set the self-timer switch to ON (red).
- 3** Depress the shutter release button halfway, make sure the mark “•” turns on in the viewfinder and depress the button all the way. The self-timer starts and the shutter trips after 10 seconds. While the self-timer is operating, the exposure counter shows the remaining time in seconds before the shutter trips. The self-timer LED and the mark “•” blinks in the viewfinder.

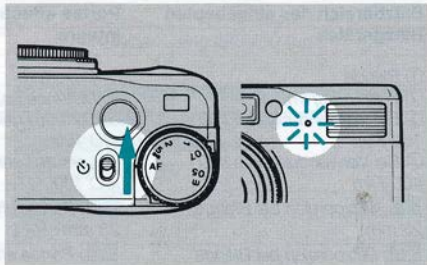

- The exposure and focus are locked when the self-timer starts.
 - If the shutter release button is depressed while the self-timer is operating, the exposure counter is reset and counts the remaining time.
 - To stop the self-timer after it has started, set the self-timer switch to OFF (black) or turn off the main switch (knob).
 - The self-timer cannot be started while the flash is charging.
 - If you are not using the self-timer, be sure to set the self-timer switch to OFF (black).
- Entfernung und Belichtung sind während der Selbstauslöservorlaufzeit gespeichert.
 - Wird während der Vorlaufzeit der Auslöser gedrückt, so beginnt der Vorlauf erneut bei "10".
 - Soll die Selbstauslöserfunktion unterbrochen werden, so schieben Sie den Selbstauslöserschalter zurück (schwarz sichtbar) oder den Hauptschalter (Knopf) auf "AUS".
 - Während des Aufladens des Blitzes kann der Selbstauslöser nicht ausgelöst werden.
 - Wird der Selbstauslöser nicht verwendet, sollte sich der Selbstauslöserschalter in der "AUS" Position (schwarz) befinden.

Bulb Exposure

If a shutter speed of 16 sec. or longer is required by the exposure metering, "16" blinks on the shutter speed display in the viewfinder. In this case, if you remove your finger from the shutter release button within 16 seconds, the shutter trips at 16 sec.

However, if you hold it depressed for more than 16 seconds, the camera switches to bulb exposure after 16 seconds have passed. The shutter remains open while it is held depressed.

While the shutter is open (during exposure), the display in the lower part of the viewfinder turns off. If it turns off, take care to avoid camera shake.



- The exposure counter switches to the bulb exposure mode and shows the time that has passed during bulb exposure. It counts from "00" to "59" (sec.), then resets itself and counts from "00" again.
- Use a tripod to prevent camera shake.

Taking Panoramic Format Pictures

By sliding the panoramic mode switch on the back of the body, the camera is switched from the normal mode to the panoramic mode, or vice versa.

- Slide the panoramic mode switch to the left or right as far as it will go. The camera may fail to operate properly if it is stopped midway.

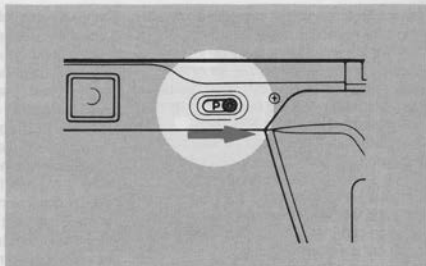

In the panoramic mode, the picture area on the film is about 13 x 36mm. When printing the pictures, an area of about 12 x 35mm on it is enlarged.

<How to Shoot>

1 Set the panoramic mode switch to the panoramic mode. The picture area frame in the viewfinder switches to the panoramic format frame.

2 Place your subject within the panoramic format frame (area that is seen clearly).

Other procedure is the same as that in the normal mode.

- When the shutter release button is depressed halfway, the picture area frame in the viewfinder changes with the shooting distance and lens focal length. To shoot, place your subject within the displayed frame.

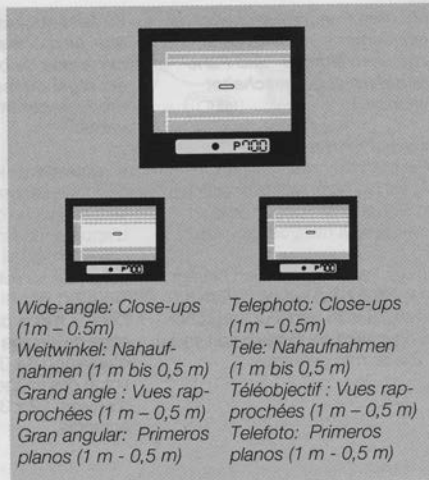

*Wide-angle: Close-ups
(1 m - 0.5 m)
Weitwinkel: Nahauf-
nahmen (1 m bis 0,5 m)
Grand angle : Vues rap-
prochées (1 m - 0,5 m)
Gran angular: Primeros
planos (1 m - 0,5 m)*

*Telephoto: Close-ups
(1 m - 0.5 m)
Tele: Nahaufnahmen
(1 m bis 0,5 m)
Téléobjectif : Vues rap-
prochées (1 m - 0,5 m)
Telefoto: Primeros
planos (1 m - 0,5 m)*

- If you are taking close-ups within the range of 0.5 – 1m, caution is required because the center of the picture area frame shifts greatly from the position of the focusing frame. In this case, do as follows:

First, aim the focusing frame at your subject and fix the focus with the focus lock.

Then, place it within the picture area frame which is displayed and shoot.

- Panoramic format pictures are horizontally long with the upper and lower portions of the standard format pictures being cut. However the field of view in the panoramic mode is the same as that in normal photography (standard format).

To enhance the panoramic effect, set the lens to the wide-angle side or move back to cover a broader area.

The number of exposures that can be taken in the panoramic mode is the same as that in normal photography (standard format).

- Bei Nahaufnahmen mit einer Motiventfernung zwischen 0,5 m und 1 m ist Vorsicht geboten, da sich die Mitte des Bildrahmens gegenüber der Fokuszone beträchtlich verschiebt. Gehen Sie folgendermaßen vor: Richten Sie das zentrale AF-Meßfeld auf das Motiv und aktivieren Sie den Schärfespeicher. Richten Sie dann den Bildrahmen auf das Motiv und machen Sie die Aufnahme.

- Bilder im Panoramaformat erscheinen horizontal doppelt so breit. Dies wird durch Maskierung des oberen und unteren Teils des normalen Bildfeldes erreicht. Die Perspektive im Panoramaformat ist jedoch die gleiche wie bei normalen Fotos (im Standardformat). Um den Panoramaeffekt zu verstärken, empfiehlt es sich, das Objektiv auf Weitwinkel einzustellen oder eine größere Aufnahmeentfernung zu wählen, so daß ein größerer Bereich erfaßt wird. In der Panoramafunktion ist die Anzahl der Aufnahmen pro Film die gleiche wie bei normalen Fotos (im Standardformat).

- If a film exposed in the panoramic mode is printed in the standard format, a black band will appear on the top and bottom of the pictures.
- If the camera is set to the panoramic mode, a panoramic mask appears as shown in the illustration. Do not touch the panoramic mask because malfunction may occur.



<Processing of Panoramic Format Pictures>

When you take your film exposed in the panoramic mode to your photofinisher for development and printing, be sure to put the specified sticker on the film cassette as described in the following table and ask for development and printing of panoramic format pictures.

Picture Mode	Sticker
Ⓐ Panoramic format and standard format pictures are mixed.	Panorama/standard mixed sticker
Ⓑ All pictures were taken in the panoramic format.	All-panorama sticker

<Vergrößern von Aufnahmen im Panoramaformat>

Achten Sie darauf, wie in der Tabelle gezeigt, den richtigen Aufkleber auf eine im Panoramaformat belichtete Filmpatrone zu kleben, wenn Sie diese zum Entwickeln bringen. Bestellen Sie Entwicklung und Abzüge im Panoramaformat.

Aufnahmeformat	Aufkleber
Ⓐ Film enthält sowohl Panorama- als auch Normalformatbilder.	Panorma- und Normalformat gemischt
Ⓑ Film enthält nur Belichtungen im Panoramaformat.	Nur Panoramaformat

- In the case of (A), it will take more days for development and printing than in the case of (B).

Also, the cost of development and printing is different between (A) and (B).

For details, ask your photofinisher.

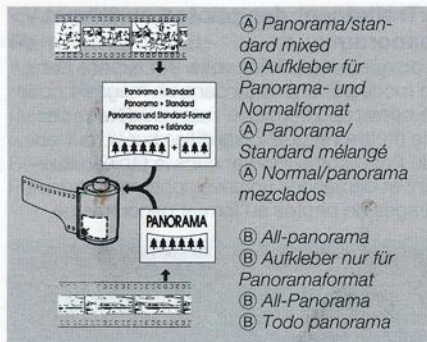

Special Functions

This camera has been set in the factory to provide basic functions for convenient use. As far as the flash mode and focusing operation are concerned, however, you can change these function settings as follows:

<1> Flash Mode

When the main switch is switched from “.” (OFF) to “)” (zoom mark) (ON), the camera is first set to the flash-auto mode (“ AUTO”). This mode is that which has been set beforehand when the camera was shipped from the factory.

However, you can change the flash mode which is set first when the main switch is turned on.

Use this special function to set the flash mode you use most often.

Sonderfunktionen

Werkseitig wurde diese Camera so eingestellt, daß ihre grundlegenden Funktionen eine praxisgerechte Bedienung ermöglichen. Auf Wunsch können Sie die Voreinstellungen der Blitz- und Fokussierfunktionen jedoch wie folgt ändern:

<1> Blitzfunktionen

Wenn der Hauptschalter von Position “.” (Aus) in Position “)” (Zoomsymbol) (Ein) gebracht wird, erfolgt zunächst eine Einstellung auf die Funktion Blitzautomatik (“ AUTO”). Dies ist die werkseitige Voreinstellung der Camera. Sie können jedoch die Blitzfunktion ändern, die beim Einschalten der Camera automatisch gewählt wird, z. B. auf die von Ihnen am häufigsten benutzte Blitzfunktion.

1 Press and hold on the flash mode button until the the flash mode displayed in the panel starts to blink (for 3 seconds or more).

2 If the flash mode blinks, remove your finger and press it again, then set the flash mode which should be set first so that it blinks.

3 The display turns on with steady light about 8 seconds after you remove your finger.

This is the flash mode which is set first when you operate the main switch next time.

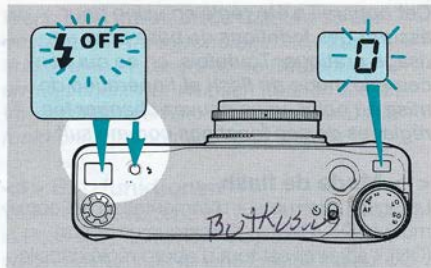

- The order of flash modes which are displayed does not change.
- Even if the main switch is turned off, or the shutter release is depressed halfway while the display is blinking, the displayed mode has been set and turns on with steady light.
- If the displayed flash mode blinks, the exposure counter also blinks.

<2> Focusing Operation

This camera is designed so that the lens is driven to focus itself after the shutter release button is depressed all the way, and then the shutter trips. However, if you put more emphasis on the shutter-tripping moment, you can change this function so that the lens is driven to perform the focusing operation when the shutter release button is depressed halfway.

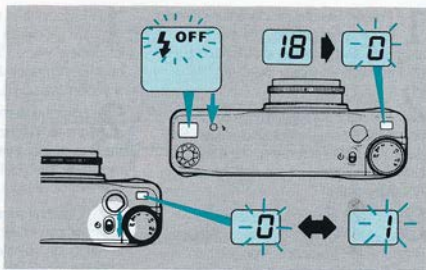

This is how to do:

- 1 Press and hold on the flash mode button until the exposure counter shows a one-digit number ("0" or "1") and blinks (for 3 seconds or more).

2 If the number blinks, push down the self-timer switch, and then, push it up again. Each time you repeat this cycle, the number on the counter changes to "1" or "0". Set your desired number.

At "0": After the shutter release button is depressed all the way, the lens is driven to focus itself and then the shutter trips.

At "1": When the shutter release button is depressed halfway, the lens is driven to focus itself and moves forward to the focusing position. After that, the shutter trips when the shutter release button is depressed all the way.

● At "1", you will hear a drive noise of the lens when the shutter release button is depressed all the way. But it does not mean that a picture has been taken.

2 Wenn die Ziffer im Bildzählwerk blinkt, schieben Sie den Selbstaüslölerschalter einmal nach vorn und dann wieder in die Ausgangsstellung.

Bei jedem Verschieben des Selbstaüslölerschalters wechselt die Ziffer im Bildzählwerk zwischen "1" und "0". Wählen Sie die gewünschte Ziffer wie folgt:

"0": Das Objektiv bewegt sich nach vollständigem Durchdrücken des Auslösers vorwärts, und der Verschluß wird ausgelöst.

"1": Bei leichtem Druck auf den Auslöser erfolgt die Entfernungsmessung, das Motiv bewegt sich vorwärts und wird in der fokussierten Stellung fixiert. Die Verschlußauslösung erfolgt nach vollständigem Durchdrücken des Auslösers.

● Bei Anzeige "1" ist beim Durchdrücken des Auslösers das mechanische Geräusch hörbar, das beim Ausfahren des Objektivs entsteht. Verwechseln Sie dieses Geräusch nicht mit dem Geräusch der Verschlußauslösung.

- If the shutter release button is depressed all the way at a stroke, however, the lens operates in the same way, whether the number on the counter is "0" or "1".

3 About 8 seconds after this operation is completed, the the counter returns to the exposure counter mode and turns on with steady light.

- The counter is also reset to the original mode and the display turns on with steady light if the main switch is turned off or the shutter release button is depressed halfway while it blinks.
- If the exposure counter blinks, the flash mode indicator also blinks because the mode has been switched be sure to reset it in accordance with the procedure described in "<1> Flash Mode".

- Wird der Verschluss jedoch in einem einzigen Schritt vollständig durchgedrückt, so arbeitet das Objektiv immer auf gleiche Weise, wobei es keine Rolle spielt, ob "0" oder "1" angezeigt wird.

3 Etwa 8 s nach diesem Vorgang erscheint die ursprüngliche Bildzählwerksanzeige wieder konstant.

- Wenn der Hauptschalter ausgeschaltet oder der Auslöser leicht eingedrückt wird, während die einstellige Ziffer blinkt, erscheint die ursprüngliche Bildzählwerksanzeige wieder, und die Anzeige leuchtet konstant.
- Bei blinkender Anzeige des Bildzählwerks blinkt die Anzeige der Blitzfunktion ebenfalls, weil die Funktion gewechselt wurde. Achten Sie darauf, die Blitzfunktion wie unter "<1> Blitzfunktionen" beschrieben rückzustellen.

Camera Strap and Soft Case (Included Accessories)

Trageriemen und weiches Etui (Standardzubehör)

*Attach the strap as shown in the illustration.
(There are two straps: a shorter S type and a
longer L type. Both types are supplied with the
camera.)*

*Fixez la courroie comme indiqué dans l'illustration.
(Il y a deux courroies : une courte de type S et une
longue de type L. Les deux sont fournies avec
l'appareil.)*

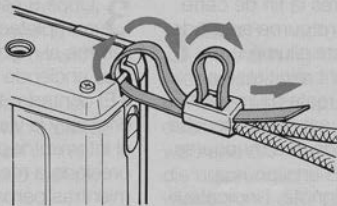

*Befestigen Sie den Trageriemen wie in der
Abbildung gezeigt. (Es stehen zwei Versionen zur
Auswahl: Typ S/kurz und Typ L/lang. Beide Typen
gehören zum Lieferumfang der Camera.)*

*Instale la correa como se muestra en la ilustración.
(Hay dos correas: una del tipo S más corta y una
del tipo L más larga. Ambos tipos se suministran
con la cámara.)*

Courroie de l'appareil et étui souple (Accessoires inclus)

The Soft Case CC-43 (included accessory) contains the camera with a filter (optional accessory), lens cap (K-31: included), and Data Back (optional) attached.

● If you attach the case to the belt, use the L-type strap to prevent the camera from dropping and hang it on the neck or pass it on the belt.

Das weiche Etui CC-43 (Standardzubehör) nimmt die Camera mit daran angebrachtem Filter (Sonderzubehör), Objektivdeckel (K-31, mitgeliefert) und Datenrückwand (Sonderzubehör) auf.

● Wird das Cameraetui am Gürtel befestigt, so ist der Trageriemen Typ L empfehlenswert. Dieser kann zur Camerasicherung ebenfalls am Gürtel befestigt werden.

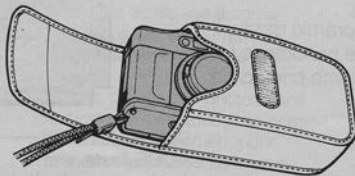

Correa de la cámara y funda blanda (accesorios incluidos)

L'étui souple CC-43 (accessoire inclus) contient l'appareil avec un filtre (accessoire optionnel), le bouchon d'objectif (K-31 : inclus) et le dos dateur (optionnel) fixés.

● Si vous fixez l'étui à la ceinture, utilisez la courroie de type L pour éviter que l'appareil ne tombe et suspendez-le au cou ou passez-le dans la ceinture.

La funda blanda de la cámara CC-43 (accesorio incluido) contiene la cámara con un filtro (accesorio opcional), tapa del objetivo (K-31: incluida), y respaldo de datos (opcional) unidos.

● Si instala la funda en la correa, use la correa de tipo L para evitar que la cámara caiga y cuélguela del cuello o pásela por la correa.

Contax Tvs Data Back (Optional Accessory)

By simply installing it in place of the camera's standard camera back, this quartz-controlled liquid crystal data back is interlocked with the camera.

Its auto-dating unit allows you to print the date or time automatically.

If you are shooting in the panoramic mode, it automatically switches to take panoramic format pictures with the date or time printed on your picture.

Display Window
LCD-Anzeige
Fenêtre d'affichage
Ventanilla de indicaciones

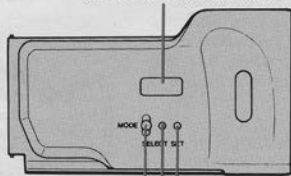

Date Mode Button
MODE-Taste
Bouton de mode de date
Botón de modo de la fecha

Set Button
SET-Taste
Bouton de réglage
Botón de ajuste

Select Button
SELECT-Taste
Bouton de sélection
Botón de selección

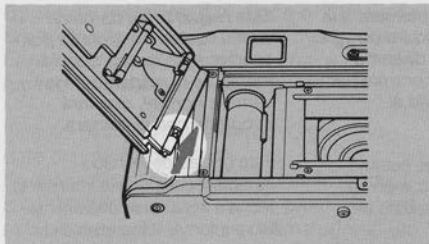

<Attaching the Data Back to the Camera>

1 Open the camera's standard camera back and detach it while pushing up the camera back release pin.

2 Insert the top of the attachment axle of the data back into the fixing hole in the camera and, while pushing up the release pin, fit the bottom of the axle into the fixing hole and remove your finger from the pin. Thus,

the data back is attached to the camera.

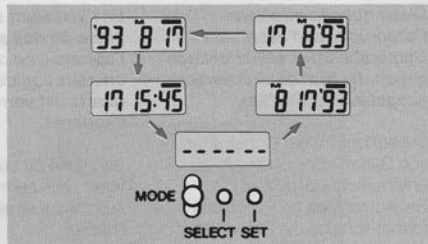

<Printing the Date or Time>

1 Choose the date mode. Each time you press the date mode button, the dating mode switches in the following order: Year-month-day → Day-hour-minute → dating-off (no date printing) → Month-day-year → Day-month-year. Set your desired mode.

2 Depress the shutter release to shoot.

- The mark " — " on the top right of the display window blinks to tell you that the date has been printed on the film.
- The letter "M" above the number stands for Month. It is not printed on your picture.
- If you do not want to print the date or time on the picture, set the dating off mode (-- -- --).
- The date is printed on the right bottom of your picture.

Caution is required, however, because the number is not clearly readable if a while, yellow or other bright-colored object is included in the position where the date is to be printed.

- In the panoramic mode, the date printing position changes automatically for panoramic format pictures.

2 Bei jeder Auslösung wird nun die gewählte Einstellung in die rechte untere Bildecke einbelichtet.

- Nach jeder Datenbelichtung blinkt die Markierung " — " in der oberen rechten Ecke der LCD-Kontrollanzeige.
- Das "M" über der Zahl bedeutet "Monat". Es wird nicht einbelichtet.
- Soll keine Einbelichtung erfolgen, so wählen Sie die Einstellung (-- -- --).
- Achten Sie bei Aufnahmen mit Datierung darauf, daß sich in der rechten unteren Bildecke ein dunkler Motivteil befindet. Vor hellem Hintergrund ist die Datierung schlecht lesbar.
- In der Panoramafunktion paßt sich die Position der Einbelichtung automatisch dem Panoramaformat an.

■ To correct the date or time

- ① Press the date mode button to show the date number you want to correct.
- ② Press the select button to make the number you want to correct blink.
- ③ Press the set button to set the correct date.
(If ":" blinks in the time display, you can set the second. Press the set button simultaneously with the time signal to set the correct time.)
- ④ After the correction is ended, press the select button until the number stops blinking.

■ Die Einstellung von Datum und Uhrzeit wird wie folgt vorgenommen:

- ① Drücken Sie die MODE-Taste und wählen Sie die gewünschte Datenart.
- ② Drücken Sie die SELECT-Taste, bis der einzustellende Wert blinkt.
- ③ Drücken Sie die SET-Taste, bis die gewünschte Zahl erscheint.
(Bei der Uhrzeit können die Sekunden während des Blinkens des ":" Symbols eingestellt werden. Ist die Zeit korrekt, drücken Sie auf die SET-Taste.)
- ④ Drücken Sie nach jeder Einstellung die SELECT-Taste, bis das Blinken stoppt.

<Replacement of the Data-back Battery>

The data-back battery is a long life lithium battery (CR2025) which lasts about 3 - 4 years. If the battery is spent, however, the printed date or time becomes light and faint and the liquid crystal display functions erratically.

In such cases, change the battery as illustrated in the figure.

- ① Open the camera back, remove the fixing screw of the battery compartment cover and open the cover.
- ② Place a new battery into the battery compartment, with the plus (+) end at top, then close the cover and fix it.

- After changing the battery, be sure to set the correct date and time.

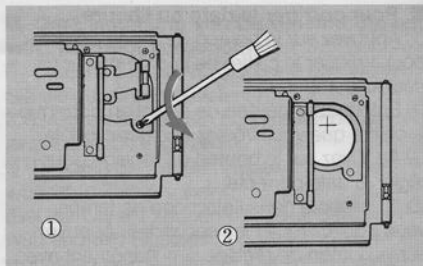

- Keep the data-back battery (CR2025) out of reach of children, in particular. In case it is swallowed, consult a physician immediately.

<Data Back Specifications>

Type: Built-in liquid crystal type quartz clock (auto calendar), automatic changeover of standard and panoramic formats.

Dating modes: Year-month-day, day-hour-minute, dating-off, month-day-year, day-month-year.

Date Printing: Automatic when the shutter trips.

Film Speed Setting: Automatic

Power Source: 3V lithium battery (CR2025)

Dimensions: 104.5 (W) x 59 (H) x 16 (D) mm

Weight: 60g (without battery).

** Specifications and design are subject to change without notice.*

- Halten Sie die Datenrückwand-Batterie (Typ CR2025) außerhalb der Reichweite von Kindern. Wird die Lithiumbatterie verschluckt, suchen Sie unverzüglich einen Arzt auf.

<Datenrückwand/Technische Daten>

Typ: Quarzuhr für Datum und Uhrzeit (mit Kalenderautomatik), LCD-Anzeige, automatische Umschaltung für Normal- und Panoramaformat.

Funktionen: "Jahr-Monat-Tag", "Tag-Stunde-Minute", "-- -- --" (keine Datierung), "Monat-Tag-Jahr", "Tag-Monat-Jahr".

Belichtungsfunktionen: Automatisch mit Verschlussauslösung.

Filmempfindlichkeitseinstellung: Automatisch.

Stromquelle: 1 x 3 Volt Lithiumbatterie (Typ CR2025).

Abmessungen: 104,5 (B) x 59 (H) x 16 (T) mm.

Gewicht: 60 g (ohne Batterie).

** Technische und konstruktive Änderungen vorbehalten.*

Dedicated Accessories (Optional)

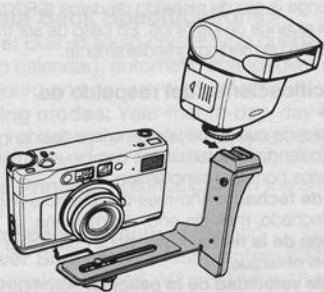

<Contax Flash Adapter SA-1>

This adapter is used for connecting a clip-on flash to the camera without a cord. It is useful when the light is not enough with the built-in flash.

<Contax Filters (30.5mm screw-in type)>

Five filters are available. P (for lens protection), 1A, L39 (UV), A2 (81B), and B2 (82A). They are screwed into the lens front.

<Contax Tvs Metal Hood (screw-in type)>

<Contax Tvs Metal Cap K-34 (slip-on type)>

A metal type hood and a metal cap for use with this hood.

The hood can be used with a filter. It is screwed into the lens front.

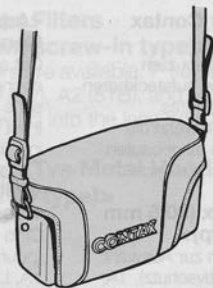

<Contax Semi-Hard Case CC-44>

This ever-ready leather case can contain a Contax Tvs with a filter, metal hood, metal cap K-34, and data back attached.

Camera Care and Precautions

- Fingermarks and dirt on the lens and other parts can adversely affect the accuracy of the camera. If they are soiled, clean them lightly with lens cleaning tissue moistened with cleaning fluid. That is enough in most cases. To remove dust, blow off with a blower or dust off with a lens brush.

- To clean the camera body, wipe off with a soft cloth.

Never use organic solvents such as benzine and thinner.

- After shooting on an ocean beach or in a dusty place, clean the camera thoroughly. Salt air can cause corrosion, and sand and dust can adversely affect the camera mechanism.

- If the camera is suddenly brought into a warm room from the outside where it is cold, the lens may be clouded.

The cloudiness will disappear after a while, but avoid sudden temperature changes if possible.

- This camera contains high-voltage circuits. In case of malfunction, never try to disassemble it by yourself because it is dangerous.

- If you are going to use the camera for important events such as an overseas trip or wedding ceremony, check to make sure it operates correctly or make test exposures beforehand. It is also recommended to bring a spare battery with you.

- The camera is a precision instrument. Do not drop it down and avoid intense shock.

<Remarks on the viewfinder>

This camera uses a polarizing plate in its optical system of the viewfinder. If you look into the viewfinder through sunglasses which use polarized light, therefore, the field of view you see will look colored. But this effect only appears in the viewfinder, but not in the picture you take.

<Using the Camera in Cold Weather>

If you are using the camera in cold weather, keep it inside your clothing to warm it up. As the temperature drops, the battery performance will be temporarily reduced and the camera may not operate. However, the battery performance reduced by low temperature returns to normal at ordinary temperature.

Protection circuit of the microcomputer:

This camera incorporates a safety circuit for protecting the built-in microcomputer against strong external electricity.

It occurs, though rarely, that the camera does not to operate when this safety circuit is activated. In this case, turn off the main switch, take out the battery, then reload it and turn on the main switch again to use the camera.

<Lens Front Ring>

This camera is designed so that the lens front ring rotates to prevent an excessive force from being applied to the lens when a filter or lens hood is attached. If the front ring begins to turn when the filter or hood is screwed in, you need not tighten it any more.

<Camera Storage>

- Keep the camera away from heat, moisture and dust and store it in an airy place. Do not store it in a wardrobe drawer containing mothballs or in a laboratory which handles chemicals.
- Do not leave the camera and film for a long time in hot places (on an ocean beach in summer, in a closed car under direct sunlight, etc.) because the camera, film and battery may be adversely affected.

Camerapflege und Vorsichtshinweise

- Fingerabdrücke und Schmutz auf dem Objektiv und anderen Teilen können die Leistung der Camera beeinträchtigen. Entfernen Sie Verschmutzungen durch leichtes Abwischen mit einem Blatt Objektivreinigungspapier, das mit etwas Reinigungsflüssigkeit angefeuchtet ist. Staub mit einem Blasepinsel entfernen.
- Zum Reinigen des Cameragehäuses reiben Sie es mit einem weichen Tuch ab. Verwenden Sie auf keinen Fall organische Lösungsmittel wie Benzol oder Farbverdünner.
- Reinigen Sie die Camera nach Aufnahmen am Meer oder an einem staubigen Ort sorgfältig. Salzhaltige Luft kann Korrosion verursachen, und die Mechanik der Camera kann durch Eindringen von Sand und Staub beschädigt werden.
- Wenn die Camera von einem kalten an einen warmen Ort gebracht wird, kann das Objektivglas beschlagen. Dieser Beschlag verdunstet nach einiger Zeit, doch sollten plötzliche Temperaturwechsel möglichst vermieden werden.
- Diese Camera enthält Hochspannungskreise. Versuchen Sie bei Funktionsstörungen auf keinen Fall selbst, die Camera auseinanderzunehmen. Dies ist gefährlich!

Specifications

Type: 35mm lens-shutter auto exposure camera.

Negative Size: 24 x 36mm (standard format), 13 x 36mm (panoramic format).

Lens: Carl Zeiss T* Vario Sonnar 28-56mm F3.5-6.5 (6 elements in 6 groups).

Aperture: F3.5 ~ 16 (f=28mm).

Shooting Range: 0.5m ~ ∞.

Zooming: Manual zoom.

Shutter: Electronic shutter for aperture-priority AE and program AE. Electronic release.

Shutter Speeds: 16 sec. ~ 1/700 sec. on program AE, 16 sec. ~ 1/500 sec. or faster on aperture-priority AE (the fastest shutter speed changes with the aperture being set).

* With shutter speeds longer than 16 seconds, the camera automatically switches to the bulb exposure mode.

Self-timer: Electronic self-timer with 10 sec. delay; can be stopped after it has started.

Exposure Control: Aperture-priority AE and program AE. With AE-Lock.

Metering Range: EV -0.4 ~ 17 (ISO 100).

Metering System: External metering system with SPD cell.

Exposure Compensation: ±5 EV (1/3-EV steps).

Film Speed: ISO 25 ~ 5000 for automatic setting (DX system); Film speed is automatically set to ISO 100 for non-DX-coded films.

Focusing: Automatic focusing with focusing dial, switchable to manual focusing.

Distance Measurement: External passive method, provided with AF-assist beam and focus lock.

Viewfinder: Real-image viewfinder, 0.38 ~ 0.68X magnification and 83% field of view (3m).

Display in Viewfinder: Picture area frame (the close-up shooting area, panoramic format shooting area and panoramic format close-up shooting area are automatically displayed by transmissible LCD), focusing frame, shutter speeds, exposure compensation marks, focusing indicators, flash mark, program mark, self-timer LED, OFF mark (displayed when main switch is off).

Panoramic Photography: Switchable to panoramic mode in mid-roll with panoramic mode button.

Flash: Built-in flash, flashmatic and guide number controlled.

Technische Daten

Flash modes: Flash-auto mode, red-eye reducing pre-flash mode, flash-off mode, fill-in flash mode. Shooting ranges: 0.5 ~ 3.7m at 28mm focal length, 0.5 ~ 2.4m at 56mm focal length (ISO 100). About 4-sec. recycle time (with new battery, at ordinary temperature).

Film Loading: Auto loading (Film automatically advances to frame No.1).

Film Winding: Automatic.

Film Rewinding: Auto-return/auto-stop system. Film can be rewound in the middle of a roll.

Exposure Counter: LCD display, automatic-resetting additive type. Lens focal length, remaining time on self-timer, and time that has passed during bulb exposure are displayed.

Camera Back: Opened and closed with camera back release knob; detachable.

Battery: 3V lithium battery (CR123A or DL123A). About 15 rolls of 24-exposure film can be exposed with 50% flash (with new battery, at ordinary temperature; according to Contax testing standard).

Dimensions: 123 (W) x 67 (H) x 41.5 (D) mm.

Weight: 375 g (without battery).

** Specifications and design are subject to change without notice.*

Typ: 35 mm AF-Kompaktzoomcamera mit Belichtungsautomatik und Blitz.

Filmformat: 24 x 36 mm (Standardformat), 13 x 36 mm (Panoramaformat).

Objektiv: Carl Zeiss T* Vario-Sonnar 3,5 - 6,5/28 - 56 mm, 6 Linsen in 6 Gruppen

Blendenbereich: F3,5 ~ 16 (f = 28 mm)

Aufnahmeentfernung: 0,5 m ~ ∞

Zoomfunktion: Manuelles Zoomen.

Verschluss: Zentralverschluss, elektronisch gesteuert mit Zeitautomatik nach Blendenvorwahl und Programmautomatik, elektrische Auslösung

Verschlusszeiten: 16 ~ 1/700 s bei Programmautomatik, 16 ~ 1/500 s oder kürzer bei Zeitautomatik nach Blendenvorwahl (die kürzeste Verschlusszeit hängt von der eingestellten Blende ab).

* Bei einer längeren Verschlusszeit als 16 s schaltet die Camera automatisch auf Langzeitbelichtung um.

Selbstausröser: Elektronisch, 10 s Vorlaufzeit, unterbrechbar, LED-Blinksignal.

Belichtungssteuerung: Zeitautomatik nach Blendenvorwahl und Programmautomatik, mit Meßwertspeicher.