

HASSELBLAD



INSTRUCTION BOOK
500C

Contents

Lens with shutter. Auxiliary shutter.
Exposure. Changing lenses. Rapid exposure.



Film transport and shutter setting.
Changing knobs.



Changing lenses. Negative sizes.
Film indicator. Loading.



Focusing hood – ground glass screen –
magnifying hood.



Fastening devices and supports.
Photographic positions.



Filters and sunshade.
Polarization filter.



Instructions for Use

You have just unpacked your shiny new Hasselblad 500 C and we know that you just cannot wait to make the first exposure. Your camera will be a faithful friend for many years, but – you must treat it in a friendly way from the very beginning. Place the camera in front of you and then read carefully through the instructions. You'll learn a lot of interesting data and discover just what a fine camera it is. On the next page you will find a description of the most important functions of your camera – learn them and you will really know its main features. Having learnt the main rules, make it a point to discover all the small finesses. Your new friend requires careful and knowledgeable handling but, in return, it will produce perfect results.

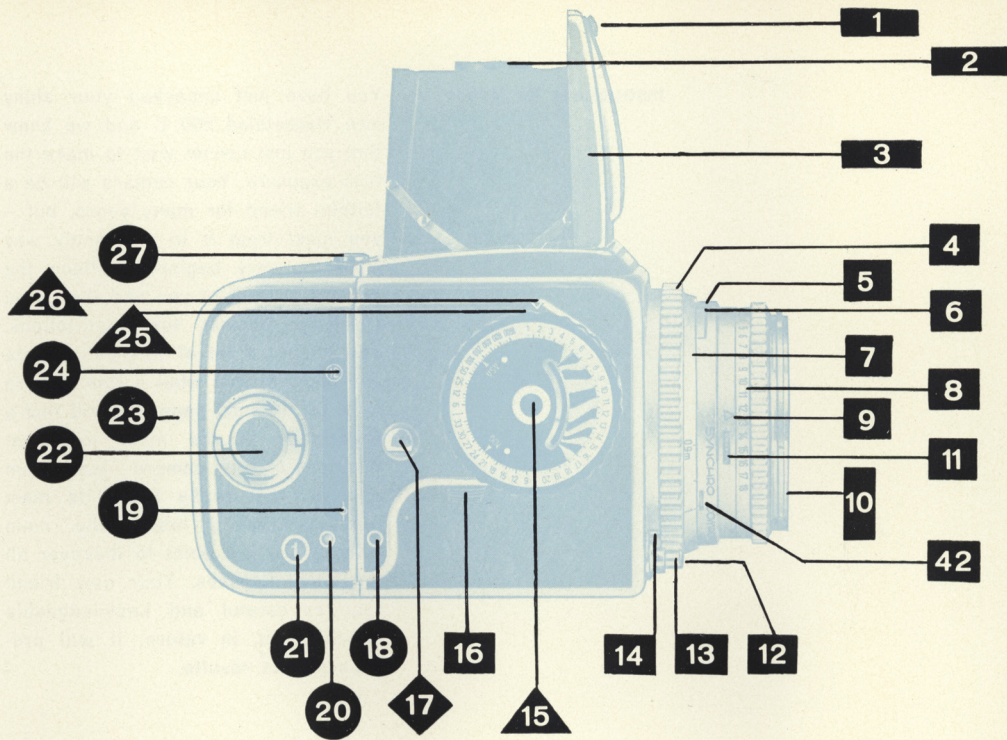

Fig. 1

- 1 Hood and magnifier release
- 2 Magnifier
- 3 Removable Hood
- 4 Focusing ring
- 5 Central index
- 6 Movable depth of field indicators
- 7 Distance scale
- 8 Exposure value scale
- 9 Exposure value index
- 10 External and internal bayonet
- 11 Exposure value catch
- 12 Cable release socket
- 13 Release button
- 14 Time catch

- 15 Interchangeable knob for film transport and shutter setting
- 16 Quick-release button
- 17 Carrying strap button
- 18 Shutter release signal
- 19 Film plane marking
- 20 Film signal
- 21 Exposure counter
- 22 Loading key
- 23 Film window
- 24 Size marking
- 25 Catch for changing knobs
- 26 Knob index
- 27 Magazine catch
- 42 Diaphragm catch

Open the focusing hood by pressing the catch to the right.

A quick "recap" before proceeding further

Before making an exposure check the magazine to see that: the slide has been removed, the film counter shows the correct number, and that the film transport and exposure signals are white.

The built-in magnifier is released by pressing the hood catch further to the right.

The hood can be removed by releasing the magazine and sliding the hood to the rear.

Set the camera to the required distance by turning the focusing ring.

The central indicator shows the aperture and shutter speed to which the camera is set.

The synchronizer is set to either "M" or "X".

Changeover catch for "M" and "X" and the self-timer "V".

Shoe for sports finder.

This catch must be depressed before "M", "X" or "V" can be changed.

Synchro-contact for auxiliary shutter and hook support for flash cord.

Press in the lens catch to release the lens from its mounting.

When changing the knob push the catch away from the camera. Turn backwards.

Attachment for motor film winder.

Interchangeable transport device consisting of knob, exposure meter, crank or motor.

Move the catch towards the camera body to release the exposure factor for resetting.

Time release for exposures of more than 1 second and self-timer.

To change places ↓ ↑

Depress the catch and the diaphragm is returned by spring pressure to the predetermined opening.

Expose with the release button. Threaded connection for cable release.

Inner and outer bayonet rings for close-up lenses, filters and lens hood.

Special base plate for rapid and secure attachment to quick slide tripod. Also, American and European tripod screw threads.

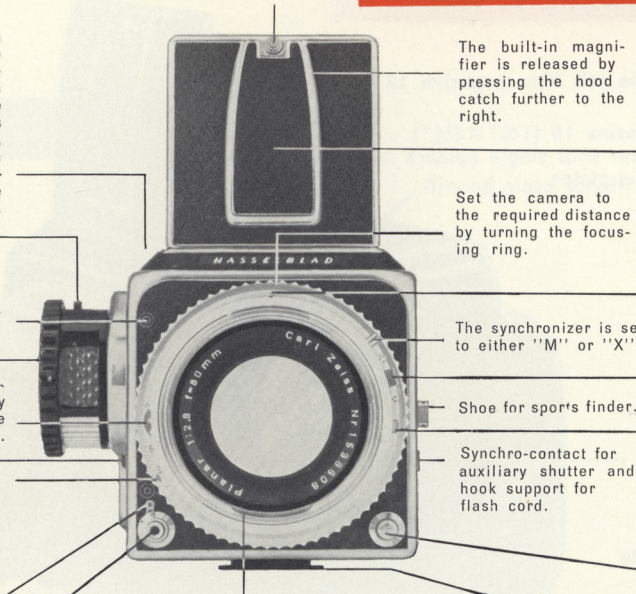

Fig. 2

The Corner Stones of the System

Interchangeable roll film magazine 12

Accessories:

Roll film magazine 16 ($1\frac{5}{8}'' \times 2\frac{1}{4}''$).

Cut film adapter with single holders for cut film and plates.

Interchangeable focusing hood

Accessories:

Magnifying hood

Ground glass screen masks.

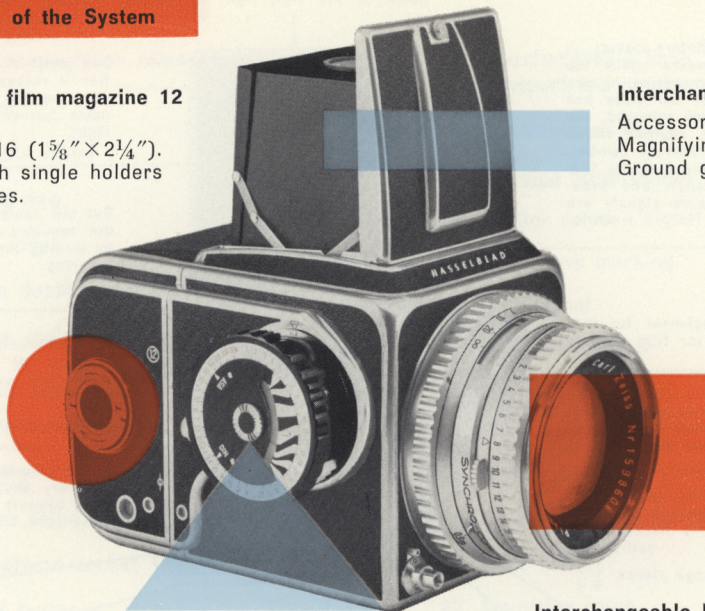

Interchangeable winding knob

Accessories:

Knob with exposure meter.

Crank winder

Motor winder.

Interchangeable lenses with between-lens shutter

Accessories:

Four top quality lenses with individual Synchro-Compur shutters.

Extension tube.

Bellows and transparency copy holder.

Microscope adapter

Fig. 3

The principle of the single-lens reflex

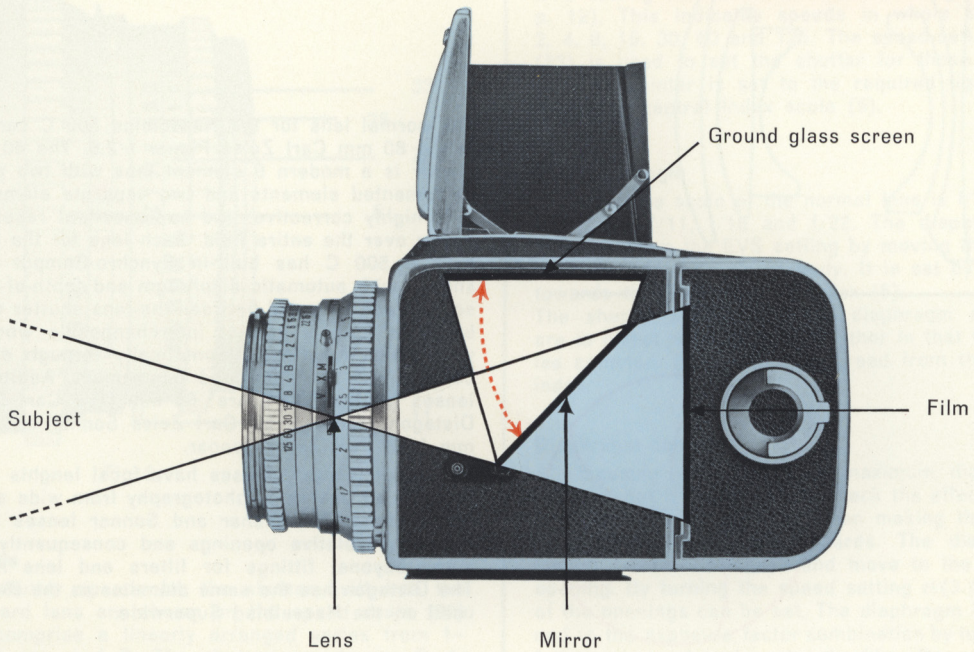

Fig. 4

Lens and shutter

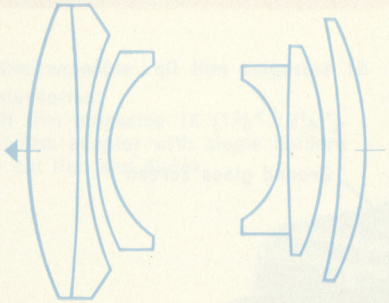
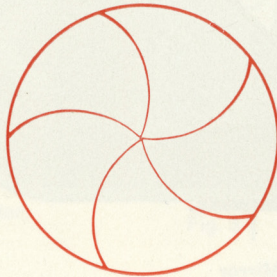

Fig. 5



The normal lens for the Hasselblad 500 C camera is the 80 mm Carl Zeiss Planar f/2.8. The 80 mm Planar is a modern 6 element lens with two pairs of cemented elements and two separate elements. It is highly corrective, and has excellent resolving power over the entire field. Each lens for the Hasselblad 500 C has built-in Synchro-Compur EVS shutter with automatic diaphragm and depth-of-field scale. Each lens and between-the-lens shutter combines to form a perfect interchangeable working unit, which functions automatically through direct contact with the film feed mechanism. Additional lenses for the 500 C are: 60 mm f/5.6 Carl Zeiss Distagon; 150 mm f/4 Carl Zeiss Sonnar and 250 mm f/5.6 Carl Zeiss Sonnar.

The supplementary lenses have focal lengths suitable for all phases of photography from wide angle to telephoto. The Planar and Sonnar lenses have the same relative openings and consequently the same bayonet fittings for filters and lens hood. The Distagon has the same diameter as the Biogon used on the Hasselblad Superwide.

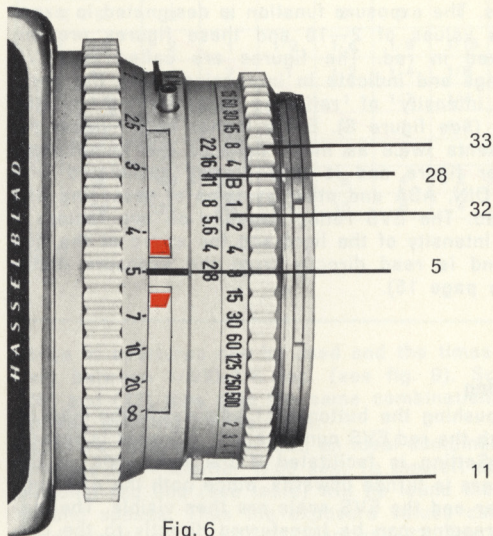

Fig. 6

Speeds

The shutter speeds for the shutter built into the standard lens are shown on the speed scale (32) and comprise a linearly arranged series from 1-1/500 sec. and B. The shutter speeds are B, 1,

1/2, 1/4, 1/8, 1/15, 1/30, 1/60, 1/125, 1/250 and 1/500. For exact exposure on B when using the EVS setting the series is continued in green (see p. 12). This indicates speeds in whole seconds: 2, 4, 8, 15, 30, 60 and 125. The speed-setting ring (33) is used to set the shutter for these speeds and the pointer is set to the required figures on the black central index scale (5).

The diaphragm

The aperture scale of the normal lens is f/2.8, f/4, f/5.6, f/8, f/11, f/16 and f/22. The diaphragm is released from the EVS setting by moving the catch (11) towards the camera body. It is set by turning towards the black central index (5).

The shutter speeds and the diaphragm aperture are in direct relation to each other in that the scales coincide. Both values are read from the same index.

Diaphragm control

All focusing takes place at maximum diaphragm opening, but it is possible to check the effect of the actual opening to be used when making the exposure. Press catch (42) upwards. The diaphragm blades are then released and move to the pre-set opening. By turning the speed setting ring (33) any of the openings can be set. The diaphragm is returned to the exposure factor combination by turning to full opening or by advancing the film after exposing.

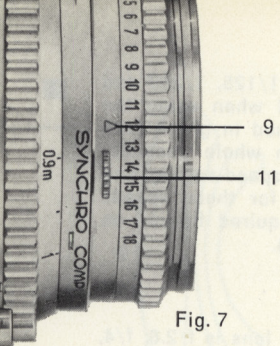

Fig. 7

Exposure value system

You will have noticed that both the shutter speeds and the aperture settings follow a linear series. This means that the two traditional factors — aperture and time — have been reduced to one common factor. See also page 9.

The object of this innovation is to arrive at the exact shutter speed for all aperture settings under the same condi-

tions. The exposure function is designated in exposure values of 2—18 and these figures are engraved in red. The figures are called the EVS ratings and indicate in increasing value the greater intensity of reflected light falling on the film (see figure 8). Every higher EVS number represents twice as much light as the immediately lower figure and is thus clearly associated with the DIN, ASA and other systems of assessing film speed. The EVS rating depends on two factors — the intensity of the light and the speed of the film — and is read directly from the exposure meter (see page 15).

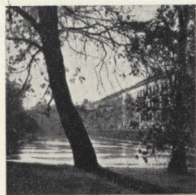

2

dark subjects give low exposure factors

Fig. 8



18

Light subjects give high exposure factors

Setting

By pushing the button (11) backwards the ring on which the red EVS numbers are engraved is released. Setting is facilitated if the right side of the camera is turned upwards, since both the exposure meter and the EVS scale are then visible. The meter reading can be transferred directly to the corresponding EVS number opposite index 9 in fig. 7. The result will be a series of aperture-shutter speeds all of which give exactly the same exposure value (see fig. 9)

Example

With an exposure value of 12 there are 7 different aperture-shutter speed alternatives. Thus the whole

| EVS | | 2 | 3 | 4 | 5 | 6 | 7 | 8 | 9 | 10 | 11 | 12 | 13 | 14 | 15 | 16 | 17 | 18 |
|----------|-----|-----|----|-----|-----|-----|------|------|------|-------|-------|-------|-------|-------|-------|-------|-------|-------|
| APERTURE | 2,8 | 2 | 1 | 1/2 | 1/4 | 1/8 | 1/15 | 1/30 | 1/60 | 1/125 | 1/250 | 1/500 | | | | | | |
| | 4 | 4 | 2 | 1 | 1/2 | 1/4 | 1/8 | 1/15 | 1/30 | 1/60 | 1/125 | 1/250 | 1/500 | | | | | |
| | 5,6 | 8 | 4 | 2 | 1 | 1/2 | 1/4 | 1/8 | 1/15 | 1/30 | 1/60 | 1/125 | 1/250 | 1/500 | | | | |
| | 8 | 15 | 8 | 4 | 2 | 1 | 1/2 | 1/4 | 1/8 | 1/15 | 1/30 | 1/60 | 1/125 | 1/250 | 1/500 | | | |
| | 11 | 30 | 15 | 8 | 4 | 2 | 1 | 1/2 | 1/4 | 1/8 | 1/15 | 1/30 | 1/60 | 1/125 | 1/250 | 1/500 | | |
| | 16 | 60 | 30 | 15 | 8 | 4 | 2 | 1 | 1/2 | 1/4 | 1/8 | 1/15 | 1/30 | 1/60 | 1/125 | 1/250 | 1/500 | |
| | 22 | 125 | 60 | 30 | 15 | 8 | 4 | 2 | 1 | 1/2 | 1/4 | 1/8 | 1/15 | 1/30 | 1/60 | 1/125 | 1/250 | 1/500 |

Fig. 9

range of apertures can be used and the times will vary between 1/500–1/8 sec. (see fig. 9). Scales (28) and (32) thus give the same combinations as the red marking on the table.

Exposure value 12 is, in fact, an ideal combination: aperture f/8 – shutter 1/60 sec. To the left of the diagonal red line (see table) will be found the full second speeds. Thus the exposure values can be used exactly even up to 125 sec. at f/22. The shutter speeds are shown in green figures. (See also fig. 10).

Variations

The exposure indicated by the exposure meter is that recommended for normal exposures. However, certain variations may arise:

1. In certain cases over- or under-exposure may be desirable. If so, there are four different ways in which the exposure can be checked.

Reduce (over-expose) or increase (under-expose)

A. At the source

1. the sensitivity value on the exposure meter.
2. or the EVS rating (page 10).

B. In the exposure combination

3. or the aperture (page 9).
4. or the shutter speed (page 9).

2. When using filters the exposure has to be increased to allow for the light absorbed by the filter (see page 35 — 36).

Setting to half units

The EVS scale can be set with great accuracy even down to half units. This is of particular importance to allow for the increase in exposure time when using color filters or when taking color photographs in general. The narrow exposure latitude of color film requires very accurate exposures and if the wrong EVS number is chosen both the exposure and the color balance may be seriously affected. Table 11 shows the aperture-shutter speed com-

Long exposure times

With EVS values of 8 and below the chances of using instantaneous shutter speeds are limited. Table 11 shows the aperture-shutter speed combinations for exposures of longer than 1 second at EVS 2-8. The green figures give the correct speeds for the relevant apertures when the shutter is set to B.

Example

Set the EVS scale to 5. For the sake of depth of field you wish to use f/11. According to the table (fig. 11) the exposure time is 4 seconds. The scales (28) and (32) on your camera show the same value as the table.

When making long exposures on color film, however, allowance must be made for the color balance correction factor.

Fig. 10

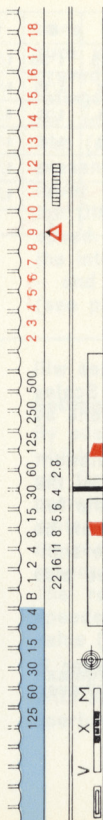

These corrections are given in the table below:

| exp. time as per exposure meter | correction factor |
|---------------------------------|-------------------|
| 1-3 secs. | 1.0 |
| 3-6 secs. | 1.3 |
| 6-10 secs. | 1.6 |
| 10-18 secs. | 2.0 |
| 18-31 secs. | 2.5 |
| 31-60 secs. | 3.0 |
| 60-130 secs. | 4.0 |

One EVS number = factor 2.0. The figures are those for Eastman Kodak Ektachrome film.

| EVS | 2 | 3 | 4 | 5 | 6 | 7 | 8 |
|------|-----|----|----|----|---|---|---|
| f/22 | 125 | 60 | 30 | 15 | 8 | 4 | 2 |
| 16 | 60 | 30 | 15 | 8 | 4 | 2 | |
| 11 | 30 | 15 | 8 | 4 | 2 | | |
| 8 | 15 | 8 | 4 | 2 | | | |
| 5.6 | 8 | 4 | 2 | | | | |
| 4 | 4 | 2 | | | | | |
| 2.8 | 2 | | | | | | |

INSTANTANEOUS SPEEDS

Fig. 11

Linear structure

As was mentioned previously, the linear structure of the scales is a basic feature of the exposure values. Since these now have exactly the same intervals as regards both position and function they are interchangeable.

The advantage of this when making separate settings on the scales is greater speed and reliability – speed in that the photographer quickly learns how to change the setting without needing to concentrate unduly, and reliability in that the scales give more accurate results than was the case previously. But, most important, by learning to apply the exposure values you develop an entirely new photographic technique.

New ideas spell progress

It is possible that experienced photographers will find the idea of exposure factors something new. They may think of it as automation, and more than the methods they have grown used to. The exposure factors have been developed with a view to making routine quicker and more certain. The scales on the camera are so placed that the time and aperture settings can be made either individually or automatically. Devote a few minutes to learning the secret of the exposure factors and you will find that they are a great help.

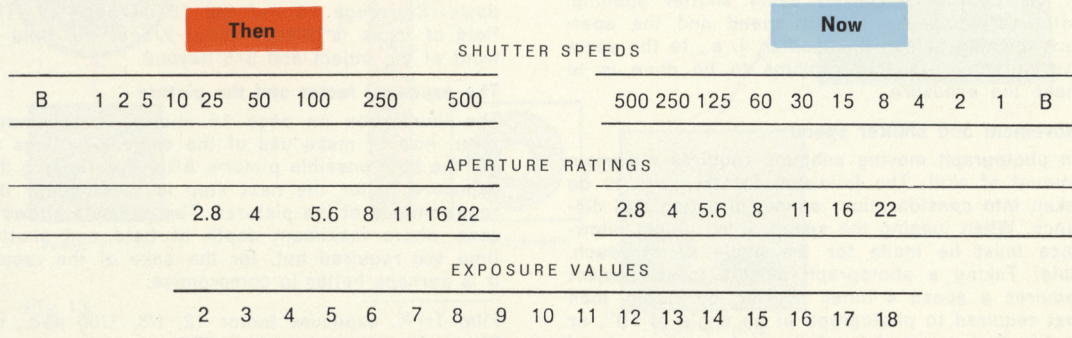

Fig. 12

Brief description of the shutter

The basic principles of the shutter operation are: the EVS number is obtained from the exposure meter, which measures the intensity of the light prevailing at the time of taking the photograph and relates this to the speed of the film in the camera. When using a filter it is necessary to correct the exposure meter reading by the filter factor. When the EVS rating has been worked out and set on the camera the exposure time and the aperture have been set in a given relation to each other. The shutter speed can then be altered to suit the motion of the object or, if a certain depth of field is called for, the aperture opening can be reduced, or "stopped down", by the required amount. The automatic depth of field indicators show the extent of the field of focus for every shutter opening. After adjusting the shutter speed and the aperture opening to suit each other, i. e., to the same overall value, all that remains to be done is to make the exposure.

Movement and shutter speed

To photograph moving subjects requires a certain amount of skill. The following factors have to be taken into consideration: speed, direction and distance. When judging the speed of an object allowance must be made for the angle of approach. Rule: Taking a photograph at 90° to the object requires a speed 4 times shorter, or faster, than that required to photograph at an angle of 10° , or double that required to photograph at an angle of

45° . The distance between the camera and the subject also influences the shutter speed. An object within 5 yards of the camera generally requires a speed 4 times faster than that required for an object at 15 yards, regardless of the angle of approach. As regards shutter speed it is generally considered that $1/60$ sec. is the slowest speed that can be used with the camera in the hand. For speeds of $1/30$ and lower a tripod should be used.

Depth of field and aperture

It will be seen from a study of the movement of the depth of field indicators (6), page 16, that the extent of the field depends on two factors: distance from camera to subject and aperture. Rule: The depth of field increases with the distance and the extent to which the lens, or aperture, is stopped down. See page 16 and fig. 15 on page 17. The field of focus is always about $2/5$ of the field in front of the object and $3/5$ beyond.

The exposure factor and the picture

The illustration on page 15 shows, in schematic form, how to make use of the camera settings to get the best possible picture. After determining the exposure factor the next step is to consider the requirements of the pictures. The example shows a case where maximum depth of field and shutter time are required but, for the sake of the result, it is perhaps better to compromise.

Film Tri-X, exposure factor 12, f/8, $1/60$ sec., no filter.

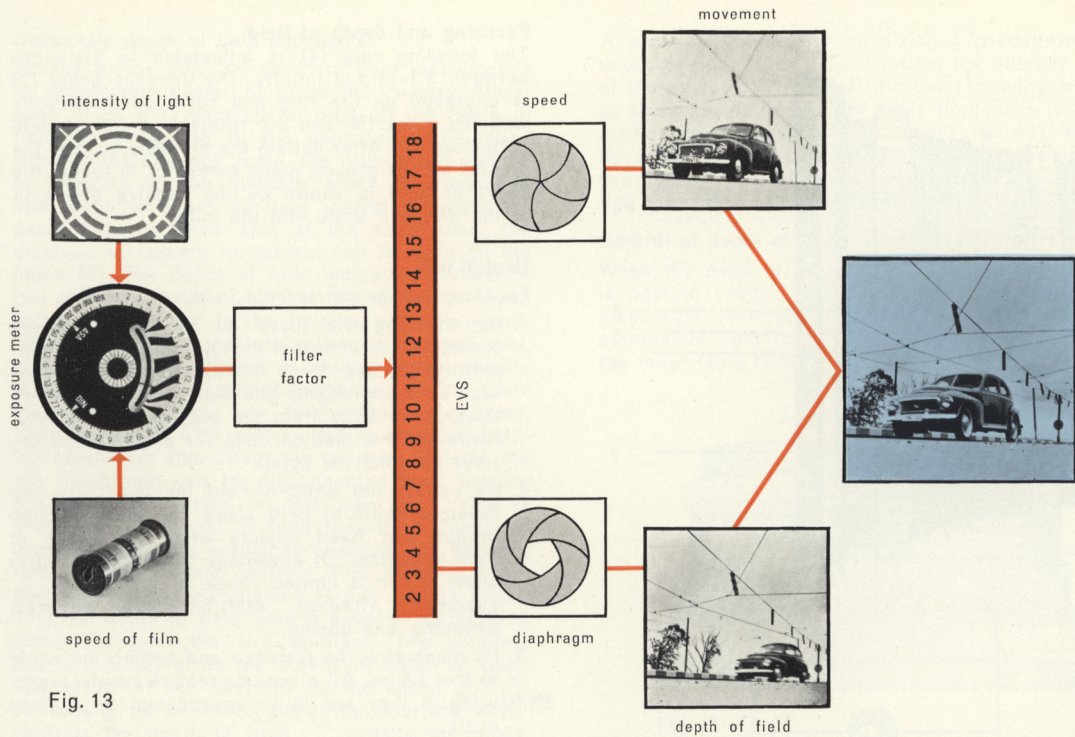

Fig. 13

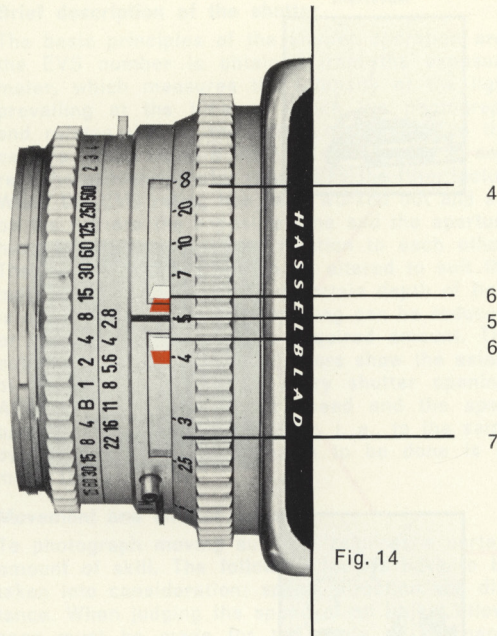

Fig. 14

Focusing and depth of field

The focusing ring (4) is adjustable to distances between 3 feet and infinity. The distance scale (7) is engraved on the ring and corresponds directly with the index (5) and the rotatable depth of field indicators (6). After setting the distance so that the picture on the ground glass screen is in focus, the depth of field is shown by the relative positions of the distance scale and the index.

Usefull tips

Focusing can be carried out in three ways:

1. By checking the focus on the ground glass screen. In the case of moving subjects at comparatively close range it may well be of advantage to focus roughly and then move the camera towards or away from the subject as it moves. However, this method calls for practice and careful attention to detail.
2. By setting the depth-of-field indicators for the required depth of field. Used in photographing groups and fixed objects when the depth of field is critical. Of advantage when taking sports shots within a limited range of focus. Examples: Hurdling, start-and-finish pictures, wrestling and boxing.
3. By measuring the distance and setting the scale to this figure. All close-ups require careful measuring if they are to be reproduced at a given scale.

Automatic depth of field indicators

Thanks to the movable depth of field indicators it is appreciably easier to focus the camera. Moreover, since it is possible to read off the depth of field corresponding to the exposure combination right on the distance scale, the roundabout method of focusing on the distance scale is eliminated. The movable depth of field indicators show the exact field of focus and, at the same time, the distance of camera to subject can be read on the index (5). The depth of field indicators consist of two parallel movable pointers. The position of these pointers in relation to the distance scale is adjusted as soon as the aperture setting is changed, and, of course, every change of shutter speed results in a corresponding change in aperture setting, since these two functions are automatically connected. Changes in the EVS setting due to changed lighting conditions also affect the aperture. Finally, the iris diaphragm can be disconnected from the exposure value setting. In this case the value is shown by the depth of field indicators. However, when the distance setting is changed, the pointers remain in the same position. Fig. 15 shows how the largest aperture opening (f/2.8) results in the smallest depth of field. This is equal to the distance shown between the two pointers. The smallest aperture (f/22) gives the maximum depth of field. The action of the aperture on the depth of field can easily be checked, since the aperture which controls the depth of field is opposite the index.

A practical method of localizing a predetermined depth of field is to focus first on the nearest part of the object and read off the corresponding value on the distance scale. The same procedure is then applied to the part of the object farthest away. By setting the depth of field indicators to these two points you will have immediately made a setting that previously seemed extremely complicated.

Control of depth of field

When the depth of field is of prime importance it is best to check the focus by stopping down the diaphragm (see page 9, Diaphragm control). All extraneous light must be avoided, e. g., by using the magnifying hood.

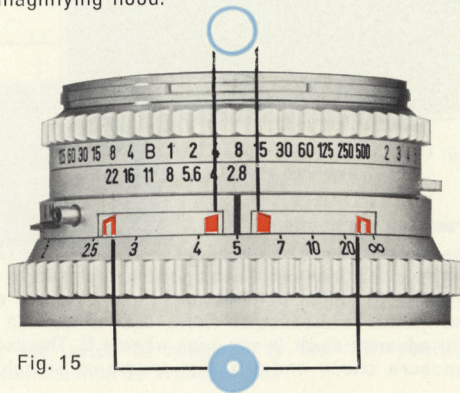

Fig. 15

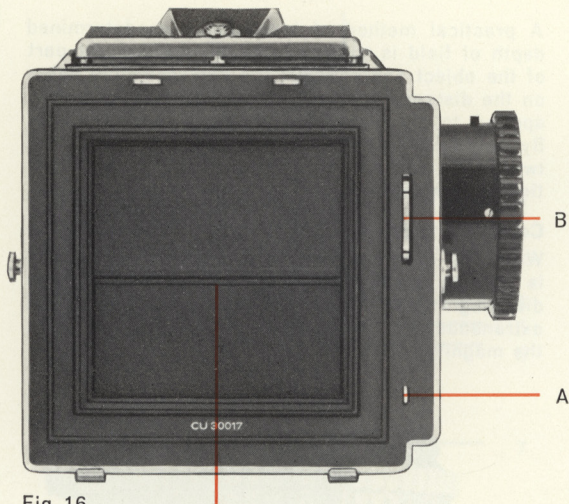

Fig. 16

Auxiliary shutter

Precision connection

The back of the camera has a profile which exactly matches the front of the magazine. Light-traps prevent the intrusion of unwanted light from the side. The power transmission from the winder to the film advance shaft is via gear wheels B. The double exposure check and the film transport signal are

controlled by the pin A. Dirt or dust at A and B may affect the efficiency of the camera.

The auxiliary shutter

The advantage of being able to use interchangeable lenses with individual between-lens shutters in a single lens reflex camera is largely due to the employment of an auxiliary shutter. This is fitted to the rear wall of the camera housing and consists of two movable blades. The auxiliary shutter will be opened by the release button and remains open as long as this is depressed. To meet special requirements it can be synchronized and in such cases the synchronizer contact is wired to the auxiliary shutter contact (36).

The auxiliary shutter is closed as long as the mirror is in the lower position and reflecting the picture onto the ground glass screen. In this way it protects the film from unwanted light. It is in the same position and fulfils the same function when changing lenses, since this can only be done when the mirror is lowered and the shutter set. The auxiliary shutter is provided with a special pneumatic shock absorber.

In addition to protecting the film from extraneous light when focusing or changing the lens, the auxiliary shutter can be used for exposures of 1/25 sec. and longer. This is recommended when the camera is being used for micro/macro-photography with a bellows extension and special lenses lacking a between-lens shutter. Use a cable release.

Exposure

The film is exposed by pressing the release button (13). A standard type cable release can be screwed into the socket (12). A general rule when exposing with the time catch (14) in position "O" is that the release button is to be kept depressed until the exposure has taken place. If the button is let up earlier, the auxiliary shutter breaks the exposure.

Camera shake is a common cause of "fuzzy" pictures. Learn to avoid this by pressing the release smoothly and firmly, and knowing when you have reached the operating pressure. If you expect to encounter sudden situations use the shortest possible exposure time.

Time catch

In certain cases the release button can be combined with a time catch (14). When the shutter is set on "B", or when the self-timer "V" is connected, the time catch is to be at position "T". When the time catch is in position "T" it serves to lock the release button, which is held in the depressed position, until the catch is returned to the "O" position. The time catch does not operate in the "O" position.

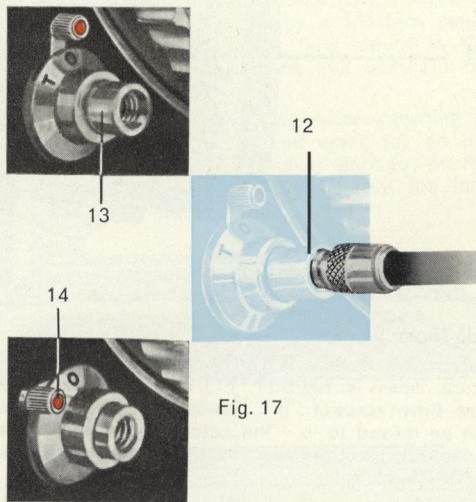

Fig. 17

Until the catch is returned to the "O" position the film cannot be transported.

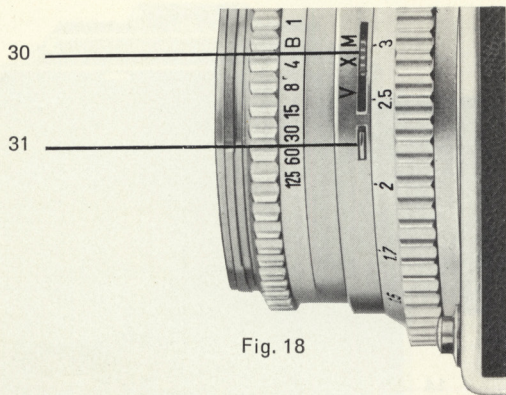

Fig. 18

Self-Timer Device

The green lever (30) engages the self-release which, when in position "V", operates at all exposure times except "B". However, before the lever can be moved to "V" the catch (31) must be pressed down. On exposure the time catch (14) is set to "T" (see page 19).

The self-timer operates $8\frac{1}{2}$ seconds after setting. The lever then returns to position X. The shutter is then X-synchronized and the camera can be used with strobe flash even with this kind of photography.

See page 22, Synchronization.

Rapid exposures

This implies reducing to a minimum the time between the instant of release and exposure. By pressing the quick-release button (16) the auxiliary shutter is opened and the mirror lifted. The picture on the ground glass screen is no longer visible and, at the same time, the aperture blades move to the predetermined position (see page 23). The quick-release button need not be held down until exposure has taken place. When the exposure is finally made by pressing the release button (13) only the between-lens shutter operates. A sports finder should be used and the focus set and checked in advance with the aid of the depth of field indicators.

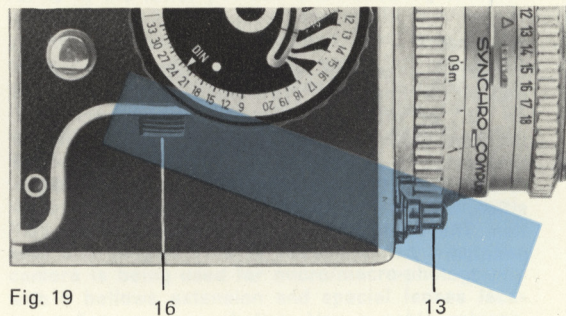

Fig. 19

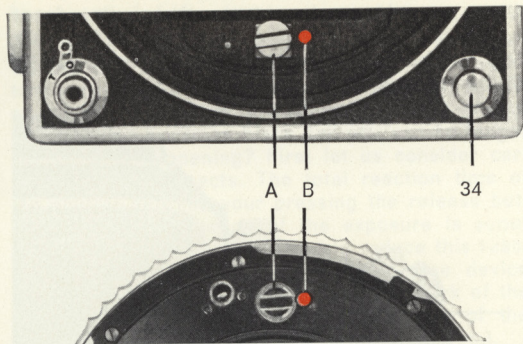

Fig. 20

Shutter setting

The shutter is cocked when the cocking shaft (A, fig. 20) is turned during the winding of the film transporter. The groove on the shaft then points to the red mark on the index "B". If the shutter was released while the lens was removed from the camera it must be re-cocked before the lens can be inserted. The simplest way of cocking the shutter is to place the edge of a coin in the groove on the cocking shaft and turn clockwise.

Changing lenses

The lens engages in a bayonet mount provided with four retaining lugs, but there is only one start point. The lens cannot be removed unless the shutter is cocked. When the lens catch (34) is depressed the lens can be removed by a 1/5 turn counter-clockwise. Hold the entire lens mount in the right hand to ensure the quick and accurate release of the lens.

The lens is in the correct position for attaching to the camera body when the red mark (o) on the lens is opposite the corresponding mark (o) on the camera. Turn the mount clockwise until the lens catch (34) clicks into position.

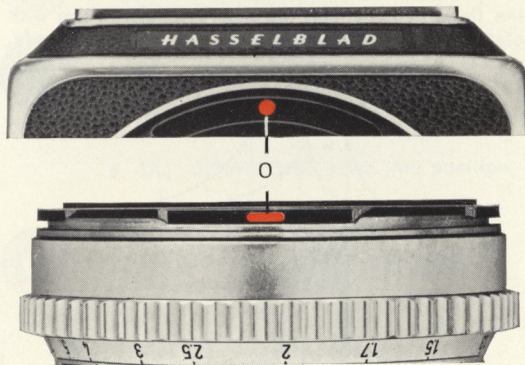

Fig. 21

Synchronization

The camera is fully synchronized for both M and X settings. The synchronizer contact (29) is of the coaxial type. The cord from the flash holder to the synchronizer contact is secured to the cable fastening with a special cable bearer (37). Switching from X to M is done by means of the green lever (30). The catch (31) must first be pressed down. The significance of M and X synchronization is explained on figure 22.

X synchronization. This is used to fire the flash when the shutter is fully open. Used primarily for strobe flash at all exposure times.

M synchronization. This delays the exposure until the flash has reached its peak intensity. Used with class M and S flash bulbs at all shutter speeds.

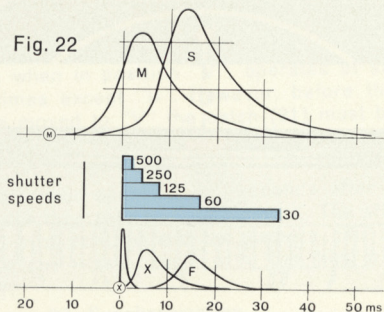

When using M synchronization the shutter speed is always shorter than the flash time of the bulb. This factor must be borne in mind when using fast shutter speeds.

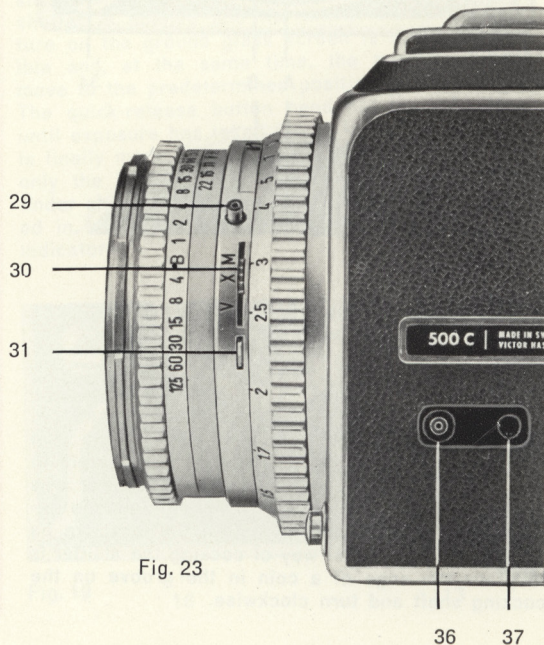

Fig. 23

The function of the shutter

If you are interested in technique you may have wondered how it is that you can focus at full aperture and yet take the picture at the aperture selected for the purpose. What happens after the ground glass screen becomes blank and you can no longer see what is happening? First let us consider certain technical aspects. The total reaction time of the shutter between your pressing the release button and the completion of the exposure is about 100 ms (1/10 sec.). If you want to reduce this reaction time you can use the rapid release device described on page 20. This divides the work of the shutter into two parts. The reaction time of the between-lens shutter is about 16 ms (1/63 sec.). In order to illustrate the technical aspect of the total reaction time of the shutter you will find that the shutter has been marked in blue in fig. 24, while the diaphragm is in red. When both these components are in function the action is depicted in violet.

The various stages of exposing

The first four stages take place when the release button is pressed. The fifth when the button is released. Stages 6–7–8 take place when the film is transported.

If you have applied the diaphragm catch described on page 9, the diaphragm will already be in the position marked by action 2 before the shutter comes into operation.



1. The shutter is closed.



2. The diaphragm takes up the predetermined position.

3. The auxiliary shutter opens and the mirror moves upwards.



4. The shutter is opened and closed. Exposure takes place.



5. The auxiliary shutter is closed.

6. The mirror moves down into position.



7. The shutter is opened and cocked.



8. The diaphragm is opened.

Fig. 24

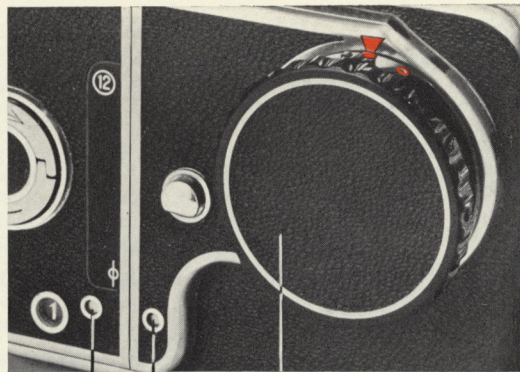

Fig. 25

Exposed film signal
 Shutter release signal
 Automatic film transport
 Shutter winding knob

Safety signals

1. Both the film transport (20) and the shutter setting (18) are white. This means that a new frame has been brought forward and the camera set for exposure.
2. Both the signals are red. The exposed frame has not been advanced and the shutter is not cocked. Advance the film.

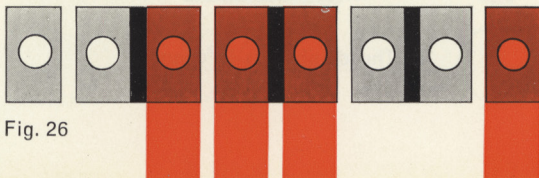

Fig. 26

Film transport and shutter setting

The film transport knob (15) has two functions, 1. to advance the next frame into the exposure position and

2. to prepare the camera for this stage. At the same time as the new film frame advances the mirror is lowered and the shutter is cocked. Cocking the shutter takes place in a clockwise direction during one turn of the film transport crank. While the shutter is being cocked the signals showing "shutter set" (18) and "film advanced" (20) are actuated. Fig. 26 shows the various combinations that may exist, for example, after changing a magazine. If, at any time, you are unable to turn the film transport knob it may be because:

1. The last film frame has been exposed, leaving no number visible in the film window (21).
 2. The time catch is at "T" and the release button has not returned to the original position. See page 19, fig. 17.
 3. The auxiliary shutter and the mirror have been released and you have not made the exposure
 3. The film transport signal is red, the shutter setting white. The magazine has been attached to the camera with the last exposed frame not advanced. The shutter is cocked and, if the release button is pressed, there will be a double exposure. This may, of course, be taken advantage of intentionally.
 4. Film transport white, shutter setting red. The magazine has been attached to the camera with a new frame in position but without cocking the shutter. To make an exposure it is necessary to re-cock the shutter. This will result in the loss of a frame.
- Rule:** When attaching a magazine to the camera ensure that the signals both show the same color, i. e., red or white.

with the between-lens shutter. See page 20, fig. 19.

4. When taking rapid-action shots it is essential that the film transport knob must not be moved to advance a new frame until the previous exposure has been completed. This factor is of especial importance when taking exposures at 1 and 1/2 sec. See "Exposure" on page 19.

Changing the winding knob

The camera is supplied with an interchangeable film transport knob (15). When connected the red mark on the knob should coincide with the triangular index (26). When changing the knob, push the catch (25) away from the camera body with the thumb of the right hand and at the same time turn the knob counter-clockwise until it is released. When attaching the knob, place the circular red mark opposite the triangular red mark and turn the knob clock-wise. It is important for you to learn this procedure thoroughly since the transport knob with the exposure meter is often used for making detailed measurements. The exposure meter is supplied as an accessory. Changing is easiest when the shutter is cocked.



Rapid winding

The movement shown in fig. 27 is recommended as the best way of advancing the film, cocking the shutter, etc. This two-way action reduces the necessary time by half and also advances the film smoothly and evenly.

Fig. 27

26

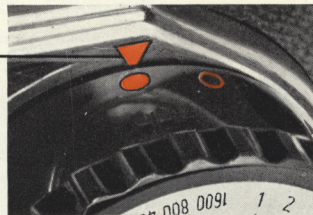

25

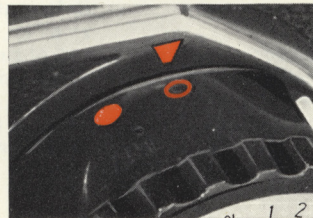
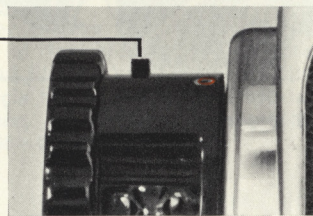

Fig. 28

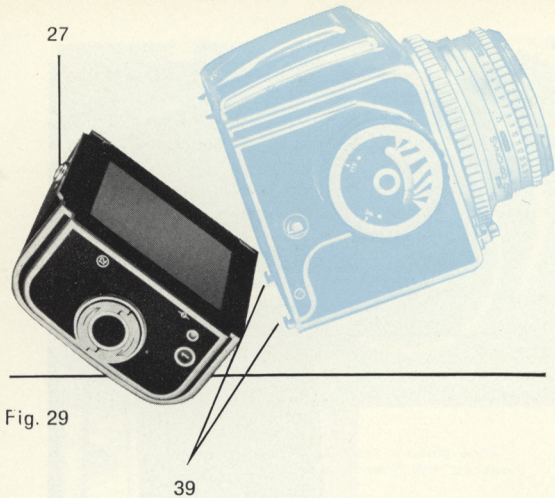

Fig. 29

Before attaching the magazine to the camera body make sure that the exposure and film-transport indicators are in the correct position (see page 24). The colors must always coincide.

Interchangeable backs

One of the major advantages of the Hasselblad camera is that you can change magazines in the middle of a roll of film. For this reason it is especially important to learn the necessary procedure at an early stage.

Place the camera in the left hand with the lens pointing away from you. Press the magazine catch (27) to the right with the thumb of the right hand and release the magazine from the catches (39). However, before the magazine can be changed it is necessary to be sure that the magazine slide (41) is in place. The slide serves the purpose of insuring that the magazine cannot be removed as long as the film is exposed. When the slide is removed you can operate the camera, but the magazine cannot be removed. When it is in position you cannot make an exposure or transport the film, but the magazine can be removed. It is important to insure that the slide is at right angles to the camera body and that the bent section (grip) is facing the front. This is to facilitate loading.

The magazine is attached to the camera in the following manner: Check that it engages properly at the hooks of the camera bottom, move the magazine towards the lock, press the catch to the right and, after the magazine is in the locked position, move it to the left. Pull out the slide and the camera is ready for use.

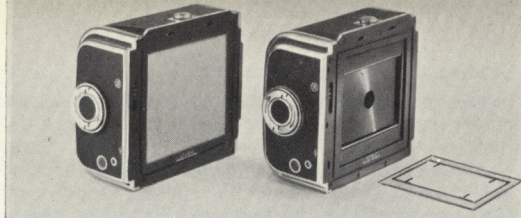

Negative sizes

Two roll film magazines can be used. No. 12 gives $12-2\frac{1}{4} \times 2\frac{1}{4}$ " exposures on 120 film. No. 16 gives $16-1\frac{5}{8} \times 2\frac{1}{4}$ " exposures on the same size of roll. Besides providing more exposures, Magazine 16 makes 16 superslide positives for 2×2 projection. The magazines are marked 12 and 16 respectively (24). The film plane markings (19) are also engraved on the metal plate showing the magazine number.

Cut film adapter

The cut film adapter enables you to make use of the wide selection of specialized negative materials available on cut film and plates. The cut film adapter takes a single holder and is fitted with all the devices necessary for precision photography. Size 6.5×6.5 cm (65×65 mm).

Fig. 30

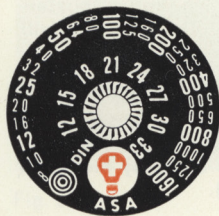
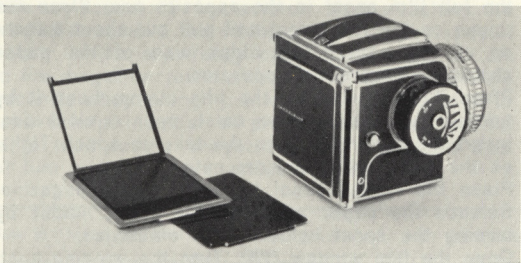

Film indicator

When working with different magazines you must make absolutely sure to note the type and speed of the film after loading the magazine. Make these notes on the film speed plate on the back of the magazine (marked ASA 6-1600 and

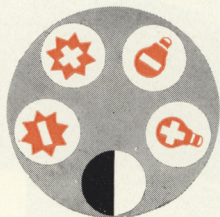

DIN 12-33). Set the exposure meter to the required film speed. The type of film is marked by symbols designating black-white, color, daylight, positive, negative.

Fig. 31

Fig. 31

Spool holder
partly pulled out

Spool holder
catch opened

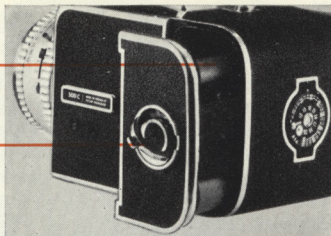

Clamp

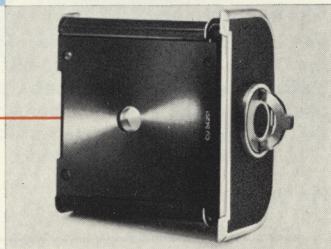

How to fit the paper
under the clamp

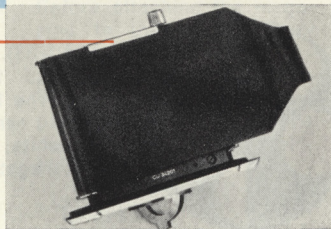

Fig. 32

Loading the roll film magazine

First release the spool holder by turning the spool holder catch (40) counter-clockwise.

Remove the spool holder. Turn the spool holder clockwise until the film clamp opens. Open the spool holder arms so that the spool and the empty spool (take-up spool) can be inserted. Place the take-up spool in the holder with the corrugated knob, and the full film spool in the opposite one. Place the thumb on the film spool and pull out about 4 inches of the paper. The black side of the paper should be towards the operator.

Place the paper under the film clamp. Lock it by turning the spool holder catch counter-clockwise. Insert the paper flap into the take-up spool. Tighten the paper with the corrugated knob.

Place the loaded spool holder into the magazine. Release the paper and lock the spool holder by turning the spool holder catch clockwise.

Open the film window (23). Turn the winding knob (22) until the figure 1 appears in the opening under the film window cover. Set the film counter (21) by turning the film winding knob counter-clockwise as far as it will go. The figure 1 will then appear (21).

After the last frame has been exposed the exposure stop comes into action automatically. The camera is then cleared and the film transport and exposure signals now show a white field. **The film is then wound onto the take-up spool by means of the magazine winding knob (22).**

Be sure that the colors in the signal windows (18 and 20) are the same before changing a magazine. See page 24.

Tips on using the roll film back

There is no need to remove the magazine from the camera when loading the roll film magazine. On the contrary, you should avoid changing the magazine unnecessarily. Immediately after attaching the magazine remove the slide, place it in the special holder in the ever-ready case. If the slide is left in the magazine you run the risk of losing valuable seconds when swinging into action. If you plan to take a large number of pictures the best method is to load several magazines with the same type of film and thus save valuable time.

Make a habit of setting the film speed indicator to the value corresponding to the film in the magazine as soon as you have loaded the magazine. Don't forget to mark the type of film. If you are using several magazines you must do this to avoid mix-ups.

Make a habit of winding back to set the film counter to "1" after transporting the film and checking the number in the film window. Failure to do this will result in an unequal division between film frames. The metal plate showing the position of the film plane is to be used for pencil notes concerning the exposure and development data. The pencil marks can be removed with an india rubber or a damp cloth.

How to thread the film

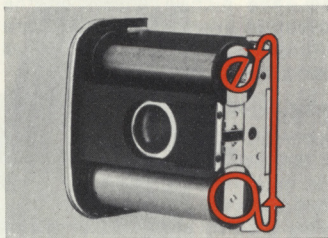

Loading key Exposure counter

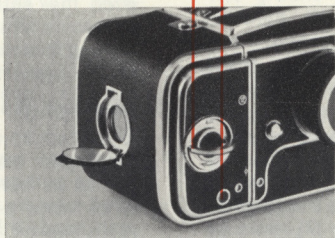

Film window opened

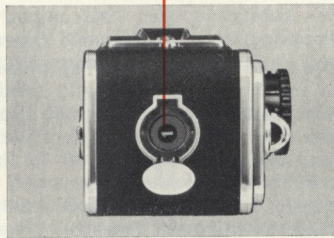
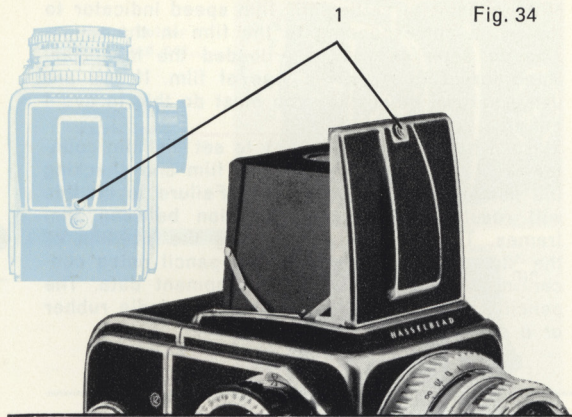

Fig. 33

Fig. 34



Focusing Hood and Ground Glass Screen

Open the focusing hood by pressing the catch (1) to the right. The hood will snap up into position and shade the picture on the ground glass screen. The fine-focusing magnifier (2) is released by pressing the catch still further to the right. To close the hood, fold the sides over the ground glass screen, then the back, and finally the front. Note: Before closing the hood the magnifier (2) must be returned to the closed position. Do not touch the surface of magnifier unnecessarily, since finger-

prints and smears greatly reduce the brilliance when focusing. Clean the glass surfaces with a soft cloth.

Fine-Focusing Magnifier

When the light hood is opened you will see a bright image of the picture. This is completely free from parallax, i. e., exactly the same picture will be recorded on the film when the exposure is made. The built-in magnifier should be frequently used to check the accuracy of focus. It has a focal length of 60 mm.

Ground Glass Screen

The ground glass screen on Hasselblad cameras is superlative. It is practically free from grain — a feature that greatly facilitates focusing in very poor light. The brilliance of the picture is greatly improved by the Fresnel Lens and the brightness is even over the entire field. The picture shown on the screen is exact and true in every detail — no more turning the camera to one side to check the focus at the corners of the picture.

Removing the Focusing Hood

Should it be necessary to clean the ground glass screen at any time the focusing hood can be removed without difficulty. If necessary a magnifying hood can be attached instead. This type of focusing hood is frequently used by professional photographers when extreme accuracy of focus is required. The hood may also be removed to permit the

insertion of masks, i. e., when Magazine 16, giving a film size of $1\frac{5}{8}'' \times 2\frac{1}{4}''$, is being used.

The focusing hood is removed in the following manner:

Remove the roll film magazine (see page 26), push the hood backwards in its grooves and remove. The hood should be folded before removal from the camera.

Magnifying Hood

This attachment is generally used when photographs are being taken in very bright surroundings. Extraneous light is completely excluded and, thanks to the turnable rubber eye-piece, focusing can be carried out more easily and with greater accuracy. The degree of magnification is $2\frac{1}{2}$ and the diopter rating can be set to between -3 and $+3.5$ to suit individual requirements. The focal length is 100 mm. The magnifying hood is supplied as an accessory and is attached to the camera in the same way as the standard focusing hood.

Fig. 35

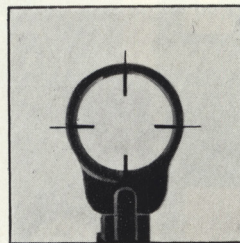
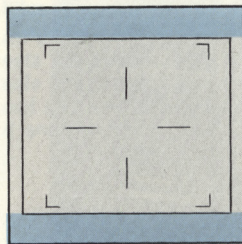
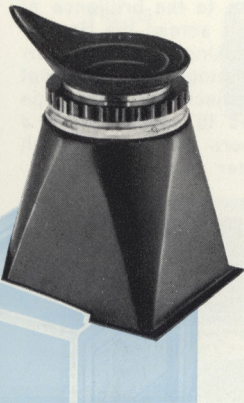

Fig. 36

Markings on the Ground Glass Screen

The ground glass screen is marked with a cross showing the horizontal and vertical planes. To avoid distortion, make the vertical and horizontal lines of the picture coincide with those of the ground glass screen.

When using the roll film Magazine 16, a special mask is placed over the ground glass screen and the focusing hood or magnifying hood placed on top of this mask. The mask is of transparent plastic and, in addition to indicating the $1\frac{5}{8}'' \times 2\frac{1}{4}''$ picture size, it shows $1\frac{1}{2}''$ square. This is to facilitate direct determination of the new Super-Slide format used with $2'' \times 2''$ projectors.



Fig. 37

Fastening Devices and Supports

The carrying strap is attached to the camera by means of the strap button (17). Secure attachment is assured in that the button and the strap can only be connected in one way. A safety spring prevents the fasteners from coming loose. The camera is carried with the strap over the shoulder or around the neck and the lens pointing downwards, thus protecting the lens surface from damage. The carrying strap also serves as a strap for the ever-ready case. It is adjustable with a simple buckle.

Methods of using the Camera

1. Basic position. Hold the camera in the left hand with the index finger of the left hand on the release button. Use the right hand to focus the camera and to set the aperture and time. Exert slight pres-

sure on the carrying strap (passing around the back of the neck) to steady the camera at the moment of exposure.

2. Three-point support. Holding the camera steady is facilitated when the magnifying hood is used. Press the eye against the eye-piece and hold the camera close to the body (as in the basic position). Additional support can be obtained by adjusting the carrying strap so that it can be held taut by inserting both hands through the strap from below and then holding the camera body. This method, which permits the camera to be held very firmly, is useful when taking pictures under poor lighting conditions.

3. "Round the corner". Thanks to the brilliance of the picture on the ground glass screen the Hasselblad is extremely useful for taking "round-the-corner" shots, i. e., when the photographer does not wish to be observed by the subject. The "periscope technique" often can be used to advantage; in a crowd, for example, the camera can be held high above the head to obtain better perspective.

Fig. 38

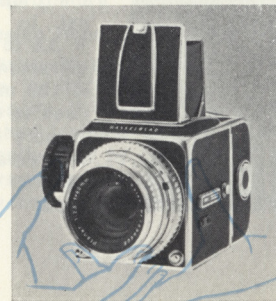

Tripod Fastening Devices

On the bottom of the camera will be found the usual American and European tripod threads, and, in addition, a quick-action attachment in the shape of a metal plate (35). This is inserted in a quick slide (supplied as an accessory). The slide is attached to the tripod pan head or ball and socket. With this accessory the camera can be secured or freed in the minimum of time. In addition, the base permits the camera to be placed on a table, or other flat support, without danger of its tipping over.

Fig. 39

35

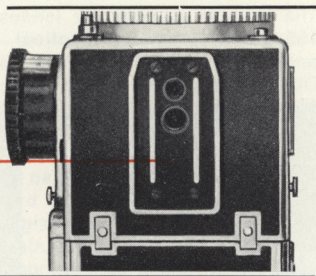

Film Winder Motor

An electric motor which winds the film forward and sets the shutter after every exposure will be available shortly. This is mounted in the film-transport and shutter bayonet catch and fastened in the holes A and the tripod nuts.

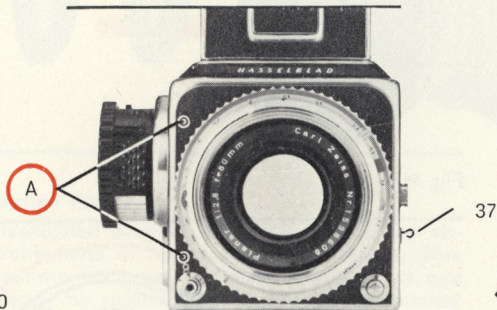

Fig. 40

Cable bearer

To keep the synchronization cord tight insert the cable bearer in the hole (37).

Sports viewfinder

The sports viewfinder is pushed into the sports viewfinder shoe (38). Preferably, the camera should be held with the sports viewfinder upwards. This does not require any special method of use.

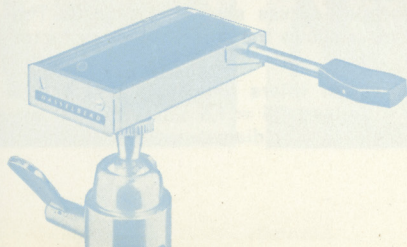



Filters and Lens Hood

The lens mount is provided with inner and outer bayonet rings (10) for the rapid attachment of a filter and the lens hood. The inner bayonet ring is used for color filters, color correction filters, the Pola-filter and the Proxar lenses. The outer bayonet ring is for the lens hood. The bayonet ring has three tongues. Any of these may be used as start points.

Fig. 41

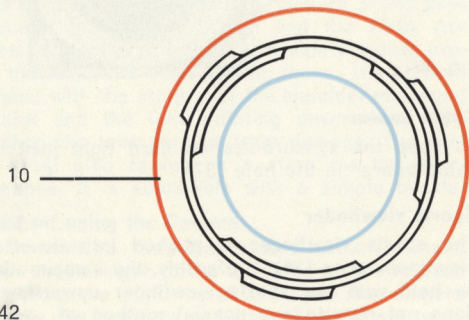

Fig. 42

Color Filters

The bayonet catches for lenses of focal length 80, 150 and 250 mm are identical. Screw in filter rings and Series VIII Filters are used for the 60 mm Distagon lens. The size designation for the bayonet filters is 50 and, for the 60 mm lens, 63. It is advisable to attach the filters so that the identification code designation comes on the right-hand side of the camera, i. e., so that the correction of the exposure factor given by the exposure meter can be easily made. The original Hasselblad filters are solid glass, and include correction, contrast and haze filters. They are mounted in black anodized aluminium rings and their effect can be determined from the absorption curves shown on page 36. The identification code shows the color, exposure factor and diameter.

Example: The yellow filters are designated Y-1,5-50, where Y = Yellow, 1,5 = 1,5 times normal exposure, and 50 = 50 mm diameter.

The increase in exposure can either be made directly on the exposure meter or by correcting the exposure factor, 1,5 times more exposure means $\frac{1}{2}$ exposure value less than normal meter reading. Of course, allowance can also be made by altering the aperture or the speed. See page 9.

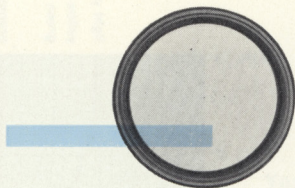

Fig. 43

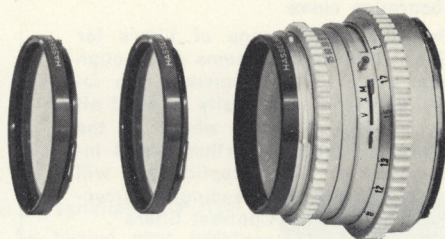
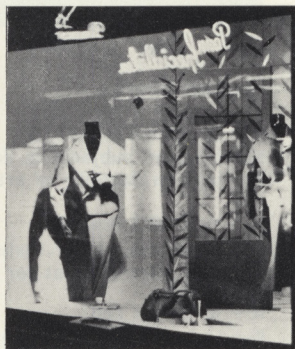

Fig. 44



Polarization Filters

The Hasselblad original Pola-filter is used to absorb reflections of highly polished surfaces. This filter admits the maximum amount of light in one plane only. By rotating the filter with the knurled outer ring the angle presented to the light can be changed. Changes in admitted reflections can be cut out provided they lie at an angle of 70° and 40° from the normal. The Pola-filter also can be used to darken a dark sky to the north. Light from this part of the sky consists largely of polarized light. It is the only filter which can be used with color film without affecting the reproduction of other colors. The Pola-filter is mounted in a black anodized ring and requires doubling of the exposure = 1 exposure value.

Absorption curve

The Hasselblad range of filters for black-white films contains a selection from those in most common use today. Efficiency can easily be read off the absorption curve, where all the filters are plotted. Further useful information on filter applications will be found under the headings "Correction filters" and "Contrast filters". Filter factors for pan film.

Correction filters

Y - 1.5. Color: yellow

Landscapes, snow, cloudy skies
Yellow and red - lighter
Blue - darker
For short exposure times

YG - 2. Color: yellow - green

Cloud effects, distance shots
Foliage and grass rendered lighter

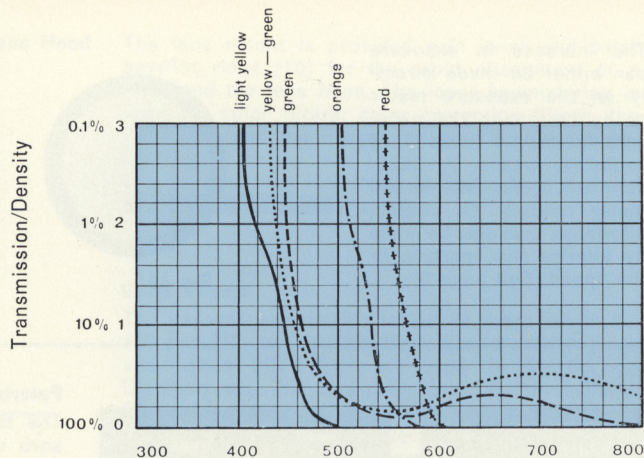

Contrast filters

G - 3. Color: green

Multicolored subjects in daylight
Portraits in daylight or artificial light

O - 4. Color: orange

Sky contrasts, richer texture outdoors
Absorbs ultraviolet at far distance shots

R - 6. Color: red

Emphasizes the effect of the orange filter

You can personalize your Hasselblad by having your name engraved on the plate facing the film window. This plate is removable for engraving – no need to part with your Hasselblad while this is being done. The plate is easily removed by putting an acute curved tool underneath by the hinge. Then undraw the plate.

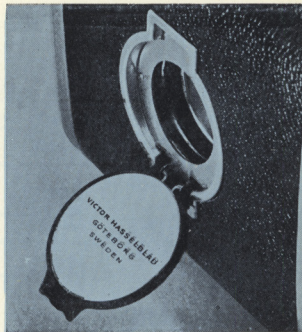

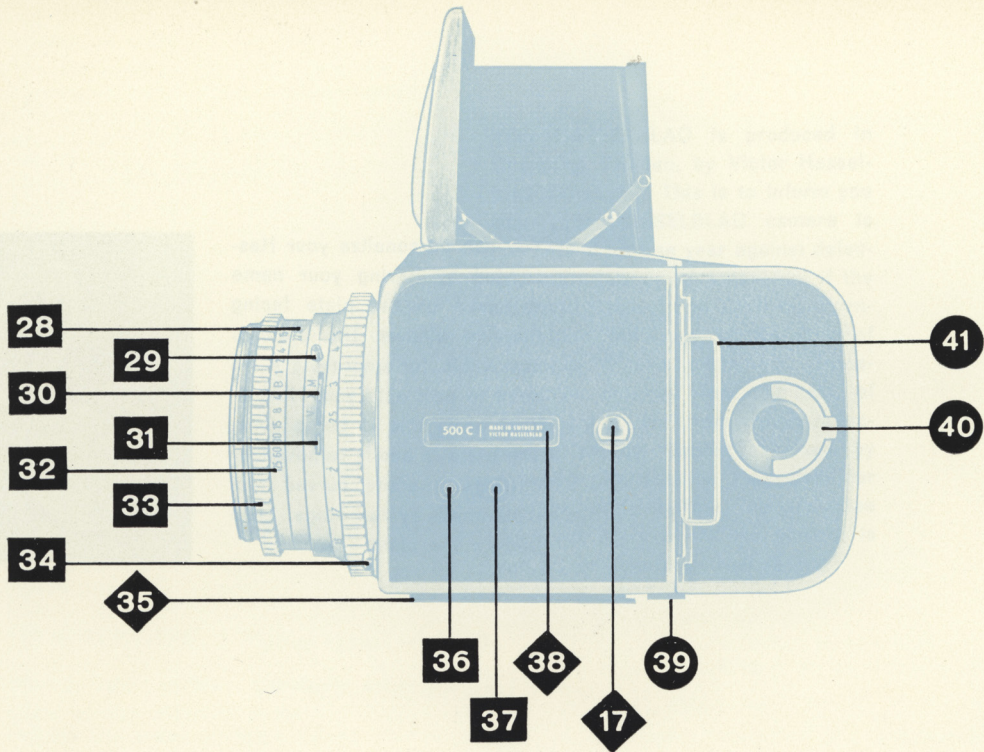

- 28 Diaphragm scale
- 29 Synchronizer contact for M and X
- 30 Bar for synchronization and self release
- 31 Catch for M X V
- 32 Speed scale
- 33 Speed setting ring for time setting, diaphragm and exposure value
- 34 Lens catch
- 35 Quick-socket for tripod
- 36 Auxiliary shutter contact
- 37 Cable bearer
- 38 Sports viewfinder socket
- 39 Locking hooks
- 40 Spool holder catch
- 41 Magazine slide

Your HASSELBLAD is produced in Göteborg, Sweden, by Victor Hasselblad Aktiebolag. This is to inform you that your HASSELBLAD camera is guaranteed for one year against defective materials or workmanship, if the enclosed Registration Card is returned within ten days of the date of purchase of the equipment. Transportation charges for shipment of equipment to and from the manufacturer's service center assumed by customer. No liability is assumed for damaged or faulty film. The guarantee does not apply where the camera is subject to abnormal treatment.

