

H A S S E L B L A D

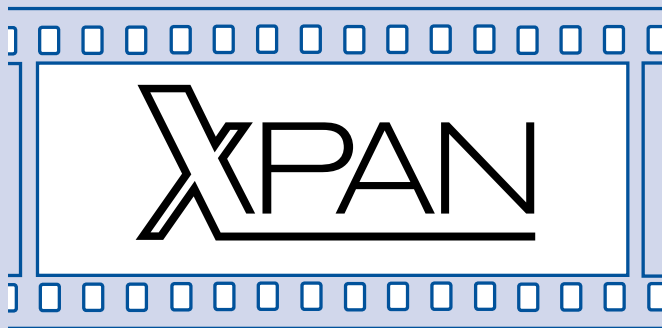

Instruction manual

ENG

XPAN

– a new way of seeing

Thank you for choosing a Hasselblad XPan. This camera incorporates an innovative dual format facility providing a 24x65 mm format – full panorama – as well as a conventional 24x36 mm format on the same film. This means you can have all the convenience and advantages of the 35 mm format but can produce an image with one side wider than the 6x6 cm format. Put simply – medium-format panorama quality from a 35 mm camera while still providing the option of the conventional format! The XPan was voted as “European Professional Camera of the Year 1999 - 2000”.

It follows on in the well-established Hasselblad tradition of superb craftsmanship founded on intensive development which has helped create the world famous name. The quality and reliability of Hasselblad equipment was clearly witnessed when it was chosen by NASA for the lunar missions.

The Hasselblad XPan is a feature-packed and highly professional tool. It includes both automatic facilities and total manual override for complete control to suit all situations and working methods. Auto exposure, auto bracketing, coupled rangefinder and pre-wind are just some of the advantageous features.

The camera body is robustly built from aluminium and titanium for the long working-life expected from such a camera. The interchangeable Hasselblad lenses are made to the most exacting standards producing excellent coverage and ‘razor’ sharpness for top quality images. Digital technology controls a host of functions making camera use simplicity itself so you can concentrate more on composition and image making.

This instruction manual describes in detail how to operate your XPan, so please read it carefully. If you have a query please do not hesitate to contact your dealer – we want you to be 100% satisfied! Your dealer can also provide you with the latest in news and technical developments from Hasselblad. A quarterly magazine – FORUM – is published with the emphasis on photographic imagery featuring photographers from all over the world to provide you with inspiration! XPan images now regularly appear. Our internet site – www.hasselblad.com – is a source of general and technical information concerning Hasselblad products while XPan has its own specific site – www.xpan.com. You can also e-mail us – info@hasselblad.se – for further inquiries.

We are sure you have made a wise choice with this exciting camera. Hasselblad have provided the possibility, it's now up to you to create the images.

We wish you good luck and look forward to seeing the results!



Contents

- 4 Contents
- 5 Introduction

- 6 Parts & components
- 7 Parts description

- 8 GETTING STARTED**
- 8 Attaching the strap
- 8 Loading the batteries
- 8 Battery check
- 8 Power

- 9 LENSES**
- 9 Lens case
- 9 Attaching lenses
- 9 Removing lenses
- 10 Lens cap
- 10 Lens components
- 10 Filters
- 10 Lens shade
- 11 Focusing
- 11 Rangefinder focusing

- 12 Depth-of field

- 12 FILM**
- 12 Film speed (ISO) setting
- 13 Film loading
- 14 Exposure counter

- 14 VIEWFINDER**
- 15 Changing the viewfinder eyepiece

- 15 FORMAT**
- 15 Standard and panorama

- 16 EXPOSURE CONTROL**
- 16 Automatic
- 18 Manual
- 18 Exposure compensation
- 19 Auto-bracketing

- 21 FILM ADVANCE**

- 21 GENERAL**
- 21 LCD illumination
- 21 Close-range photography
- 21 Film plane index
- 22 Self-timer
- 22 Infrared photography
- 23 Flash
- 23 Cable release
- 23 Mid-roll rewind
- 23 Exposure history
- 24 Film processing

- 24 ACCESSORIES**

- 26 TIPS & REMINDERS**
- 28 Viewfinder eyepiece selection
- 29 Troubleshooting
- 30 Technical specifications
- 33 Equipment care, service and guarantee

Hasselblad XPan

Become familiar with the various components on the camera by checking them against figs 1–3 and the component list. Avoid touching the lens surfaces and take care regarding the focal plane shutter and format blind when opening the camera back.

Begin by loading the batteries so that you can go through all the camera's functions. The XPan is a very simple camera to operate following well-established routines and most photographers should be able to successfully operate it straight away without any problems.

The mode selector switch is the main ON/OFF control which activates the camera. Information is provided by two LCD panels and an LED display in the viewfinder. Read quickly through the main items in this manual for a general overview of the information system and the mechanics of the camera. Then read again more carefully the relevant sections to gain a firmer understanding of individual

procedures. Fluency in operation of the camera will allow you to concentrate more on picture taking.

In the text, the main LCD on the back of the camera is referred to as 'M/d' and the small exposure counter LCD as 'EC/d'.

Positions of components and orientation are described in relation to the camera as seen when taking a photograph, i.e. with the lens at the front, unless otherwise stated.

The relevant illustrations are indicated by the figures beside the small headings in the text.

Please read 'Film processing' before sending your exposed film to a film laboratory.

Parts & Components

1

1. Film speed (ISO) dial index
2. Film speed (ISO) dial lock
3. Film speed (ISO) dial
4. Lens release button
5. PC flash terminal
6. Viewfinder window
7. Self-timer lamp
8. Bright frame illumination window
9. Rangefinder window
10. Hot shoe

2

11. Format selector knob
12. Format selector release button
13. Viewfinder eyepiece
14. Cable release socket
15. Strap lug
16. Film type window

17. Camera back release catch
18. Tripod socket
19. Battery compartment cover
20. Main LCD display panel (M/d)
21. AEB button
22. LCD illumination button
23. Mid-roll rewind button

3

24. Shutter speed selector dial
25. Shutter speed selector lock
26. Shutter speed selector index
27. Film plane index
28. Shutter release button
29. Exposure compensation dial index
30. Exposure compensation dial
31. Exposure counter LCD (EC/d)
32. Shooting mode selector
33. Shooting mode selector lever

Parts Description

The following is a concise introductory description of the major parts of the camera (the figures refer to the illustrations 1–3). Details of functions and procedures can be found under the appropriate sections and headings further on in this manual. See the main index for details.

2. **Film speed (ISO) dial index lock** – releases selector from automatic (DX) film speed setting.
3. **Film speed (ISO) dial** – for automatic (DX) and manual film speed setting.
5. **PC flash terminal** – for flash connection via cord.
7. **Self-timer lamp** – countdown timer for shutter release when set at self-timer mode.
10. **Hot shoe** – accessory shoe with direct contact for flash units.
11. **Format selector knob** – for standard and panorama format.
14. **Cable release socket** – for vibration-free or remote shutter-release.
16. **Film type window** – for confirmation of whether camera is loaded and film type.

17. **Main LCD display panel** – main information panel. (Referred to in the text as ‘M/d’)
21. **AEB button** – auto-bracketing mode.
22. **LCD illumination button** – information and exposure LCD illumination.
23. **Mid-roll rewind button** – for rewinding film before completion.
24. **Shutter speed selector dial** – for manual or automatic shutter modes.
25. **Shutter speed selector lock** – releases selector from automatic setting.
27. **Film plane index** – for critical focusing distance measurement.
28. **Shutter release button** – for camera activation when pressed half way and shutter release when pressed completely.
30. **Exposure compensation dial** – for rapid exposure variations from normal exposure settings.
31. **Exposure counter LCD** – indicates number of unexposed frames left on film and format indication. (Referred to in the text as ‘EC/d’)
32. **Shooting mode selector** – for choice between S, C and self-timer modes.

Getting Started

Attaching the strap

4

With the buckle and retainer already attached to the strap, pass the strap end first through the strap lug on the camera, then through the retainer and finally back through the buckle again. Allow at least 2–3 cm of loose strap beyond the buckle. See the illustration for details.

Loading the batteries

5, 6

Set the shooting mode selector to 'OFF'. Unscrew the battery compartment cap – situated on the baseplate – counter-clockwise several turns by inserting a small coin or similar in the groove. Insert two fresh batteries (Lithium CR2- 3V) with the terminals positioned as in the illustration. Replace the cap and screw clockwise several turns until secure.

The camera is wholly battery dependent and so it will not function in any way if the batteries have been omitted, are exhausted or have been fitted incorrectly. Always use fresh batteries and do not mix old with

new. Please discard used batteries in an environmentally correct way.

Battery check

7

Set the shooting mode selector to S, C or \odot . The M/d will indicate the battery status by the following icons:

- The battery capacity is adequate.*
- The batteries are low. The camera will function but replace batteries soon.*
- Flashing battery icon. The batteries are exhausted and the camera will not function.*

The battery check icon is always visible when the camera is in active mode. Check battery status regularly.

Power

8, 9, 10, 11

ON

Set the shooting mode selector to S, C or \odot .

- S – single exposure mode*
- C – continuous exposure mode*
- \odot – self-timer mode*

Without film in the camera, the M/d will display an ISO symbol, the manually set ISO rating (or '100' in the case of an automatic DX setting) and a battery icon, see fig. 9 for example. When loaded with film, however, the

EC/d will also display a figure that shows the number of unexposed frames left on the film (fig. 10).

When the shutter release button is pressed halfway down, the 'ISO' symbol disappears and a 'Tv' symbol appears (time value) together with the selected shutter speed (fig.11). After ten seconds of no response, the 'ISO' symbol appears again, replacing the 'Tv' symbol.

OFF

- Set the shooting mode selector to 'OFF'
- All indications on both LCD's disappear.

POWER SAVE

After three minutes of no response from the camera controls, all indications on the LCD's will disappear and the camera switches over to stand-by status automatically.

The camera will reactivate when:

- the shooting mode selector is moved from 'OFF' to S, C or \odot .
- the shutter release button is pressed halfway down
- the cable release is operated (see 'Cable release')
- the LCD back light illumination button is pressed
- the camera back is opened or closed
- the AEB (auto bracketing) button is pressed

Lenses

The XPan uses interchangeable bayonet-fitting Hasselblad lenses specifically designed for the XPan. Three lenses are available: a 30mm Aspherical, a 45mm and a 90mm. The following is general user information for both the 45mm and the 90mm lenses. The 30mm lens requires more specific information and is therefore supplied with its own user manual. See the 'Technical Specifications' table towards the end of this manual for further details of all three lenses as well as depth of field tables for the 45 mm and 90 mm lenses. Further information on filters can also be found under 'Accessories' towards the end of this manual.

Lens case

12

The lens case consists of a cover, cover base and an integral rear lens cap. The lens cover is unscrewed approximately 1/8 turn counter-clockwise to remove. The lens can then be unscrewed approximately 1/8 turn counter-clockwise to remove from the base. If, however, you continue to turn the lens counter-clockwise, the rear lens cap will also be released from the base. As the cap is then also free from the lens, take care not to drop it.

Lens cap

13

The lens cap is removed and attached by pinching inwards the two projections on the rim of the cap to release its grip.



Always replace the camera body protective cover and the lens caps when camera and lens are separated.

Attaching lenses

14

Firstly, turn the protective cover on the camera body counter-clockwise and remove it. Align the index on the lens with the index on the camera body. Gripping the lens by the knurled attachment ring, turn the lens clockwise, when seen from the front, until it clicks and locks into position. The camera automatically adjusts the frame in the viewfinder to match the focal length of the chosen lens.

Removing lenses

15

Gripping the lens by the knurled attachment ring, turn the lens in a counter-clockwise direction while depressing the lens release button.



Always grip the lens by the attachment ring when attaching and removing and not by the aperture ring, focusing ring or lens shade.

Lens components

16

1. Aperture scale
2. Aperture index
3. Focusing ring
4. Lens attachment alignment index
5. Distance scale
6. Depth-of-field scale
7. Central index
8. Infra red index
9. Attachment ring

Filters

Standard screw-threaded M49 mm filters should be used. The use of two or more filters together may produce problems with vignetting and lens shade attachment except with dedicated Hasselblad M 49 mm filters described below. As the XPan has a TTL exposure system, filter factors – the amount of exposure increase necessary for each filter – can in general be ignored as they are automatically taken into account. Tests or alternative exposures should be made in special cases, however, to ensure the required result.

Three dedicated Hasselblad filters are available. A UV/Sky for general purposes and two centre filters (with respectively 30mm and 45mm/90mm fitting) for critical applications using transparency film. Each filter

can also be combined with one additional dedicated Hasselblad filter or a filter with a narrow, low-profile ring.

See under 'Accessories' for further information about dedicated UV/Sky and Centre filters for Hasselblad XPan lenses.



When using filters and a hand-held meter, be sure to include any filter factors in the exposure calculations.

Lens shade

17,18

Match the red index on the rear of the XPan lens shade (see illustration) with the red index on the lens. Turn the lens shade (bayonet fitting) counter-clockwise (when seen from behind the camera) until it clicks into place. XPan lens shades have been specifically designed for XPan lenses; other types of lens shade are not recommended. The XPan lens shade is designed so that it should be removed first before a filter or lens cap is attached, changed or removed.



When an XPan lens shade is fitted, there is a partial blocking of view in the bottom right of the viewfinder image. However, this in no way affects the results.

Focusing

The lens is focused by turning the rubber covered focusing ring that surrounds the lens barrel. Focusing can be either visual, via the viewfinder/rangefinder system, or manual. For the former see 'Rangefinder focusing'. For manual focusing align the chosen distance on the distance scale against the lens central index.

Rangefinder focusing

19,20

The rangefinder is a coupled-type in the form of a small, bright rectangle in the centre of the field-of-view frame in the viewfinder that provides a superimposed 'ghosted' image of a central part of the subject (fig 19). The lens is turned until the 'ghosted' image coincides with the subject image (fig 20) producing a sharp focus setting for that particular distance from the camera. You may find that subjects containing few or no lines or sharp contrasts in the image are more difficult to focus. Try pointing the camera to other areas of the subject containing vertical lines or contrast changes that are approximately the same distance away from the camera, focus at those points and then return to your original composition. You may also find it easier to turn the camera on its side if there are only horizontal lines within the image, for example, when pho-

tographing a near horizon. Alternatively, the distance can be estimated and the distance scale on the lens aligned accordingly against the central index.

 *Look directly into the viewfinder and not from an angle otherwise it can result in inaccurate focusing.*

Depth-of-field

21

Depth-of-field – the amount of acceptable sharpness produced at a given aperture and focus setting – can be calculated as in the following example:

The aperture has been set at f/11 and the focus at 3 metres. By reading across from the relevant aperture markings on the depth-of-field scale on either side of the central index to the focusing distance scale, you can see the extent of the sharp zone. In this example the depth-of-field ranges from approx. 2 m to 7 m.

There are two tables at the end of the illustration section of this manual that describe the depth-of-field produced by the various combinations of aperture settings and focus settings regarding 45mm and 90mm lenses. For example, when focused at 2 m and set at f/8, the depth-of-field extends from 1.61 to 2.66 m with the 45 mm lens and from 1.89 to 2.13 with the 90 mm lens. See separate user manual for 30mm depth-of-field table.

Film

Film speed (ISO) setting

22

If you want to expose the film at the recommended speed (ISO/ASA/DIN) and the film has a DX code strip on it (a large pattern consisting of exposed metal surfaces) then set 'DX' on the film speed dial against the index on the camera body with the shooting mode selector set at 'OFF'. The 'ISO' symbol appears on the M/d and the corresponding ISO rating is indicated after loading the film.

If, however, the 'ISO' symbol appears together with '100' flashing, this is caused by one of the following:

- *There is no film in the camera.*
- *A film without a DX code has been loaded.*
- *A film with an abnormal DX code has been loaded.*

If there is no DX code strip on the cassette or you want to alter the recommended ISO rating of the film, manually set the 'ISO' dial. Do this by pressing the film speed dial lock while turning the dial to the required value. The dial remains locked only at the 'DX' setting and so it can be freely adjusted from any other setting without

having to depress the lock button again. The dial can be set at 1/3 intervals from ISO25 through 3200 and the selection will be visible on the M/d. Proceed to load the camera as described below.

 *Make a manual ISO setting before using an un-coded cassette, otherwise the camera will not load the film.*

 *If you make a manual ISO setting do not forget to make the appropriate changes afterwards for the next film.*

Film loading

23, 24, 25

In subdued lighting, lift the camera back release catch as in the illustration and push upwards. The camera back will now be released.

 *Be careful not touch the shutter or format blinds with your fingers or let a film cassette drop onto them!*

With the shooting mode selector set at 'OFF', insert a 35 mm film cassette into the film compartment as in the illustration. Note which way round the cassette is inserted. Tilt the 'top' of the cassette a little at first so that the cassette is seated securely in the compartment. Pull out just

enough – but no more – film leader to align the tongue of the film against the green 'film tip' index line so that it rests on the take-up spool. Ensure the film is laying down flat against the shutter housing and the cassette opening is pulled down accordingly. If the film bows upwards it may pull the film tip back and away from the index position. Carefully close the camera back. Press the left part of the back towards the main camera body until you hear a click to ensure it is locked. The film is automatically withdrawn completely from the cassette, set at the first frame and the camera power turned off.

 *If a non-DX film has been loaded while the ISO selector was set at DX then it will not be wound forward and the camera will not operate. Turn the shooting mode selector to 'OFF' and manually set the ISO dial.*

 *Load the camera with the mode setting at 'OFF'*

While the film is being withdrawn, the M/d will show the film speed while the EC/d will count down the exposures. When the film has been completely withdrawn from the cassette, both LCD's will go off. On reactivating the camera, the EC/d will indicate the number of

exposures remaining.



The number of exposures remaining will depend on the format setting. Therefore with a new 36 exposure cassette, for instance, the counter will show 36 exposures at standard format but only 21 at panorama format.



If the exposure counter does not show how many exposures are remaining, it is an indication of a fault. Open the camera back and re-align the tip of the film with the take-up spool.



If the exposure counter flashes, it is an indication of a fault. Rewind the film and reload the camera.



The camera will appear to operate normally even if it is empty. However, no figures will be visible in the EC/d and of course no information can be seen in the film type window!

Exposure counter

26

The EC/d indicates the number of unexposed frames remaining, automatically changing after every exposure. It also takes into account the chosen format setting automatically. This means that by switching the format selector knob back and forth, you can see

how many frames are remaining in either format at any time. The figure '1' indicates the last frame and when that has been exposed the camera automatically rewinds the remainder of the film into the cassette. When the motor stops, the exposure counter will indicate 'E' (empty).

Viewfinder

The viewfinder is a coupled rangefinder type with the additional feature of automatic field-of-view frame change according to the focal length of the lens and chosen format. The field-of-view frame also moves automatically to compensate for parallax error when photographing close subjects. The 90 mm lens produces a larger rangefinder double-image compared to the 45 mm lens.

The viewfinder eyepiece is interchangeable to suit individual eyesight.

Changing the viewfinder eyepiece

27

The standard dioptre of the viewfinder eyepiece is -1.0. Five other strengths are available: +2D, +0.5D, -2D, -3D and -4D. The eyepieces simply slides in and out of the viewfinder frame, clicking into position. It can be released by inserting a thin object in the notch at the bottom of the frame.

Please refer to the 'Viewfinder eyepiece selection' table towards the end of this manual for a detailed description of choice.

Format

Standard

28a

For the standard 35 mm format (24 mm x 36 mm) turn the format selector knob to align the indexes (counterclockwise if already set at the panorama format) while keeping the centre button depressed. The viewfinder will automatically display the correct format framing and the exposure counter will indicate the number of frames remaining at that chosen format.

Panorama

28b

From the standard format, turn the format selector knob clockwise while keeping the centre button depressed and align the indexes to the panorama format. The letter 'P' will be visible on the top of the dial. Again the viewfinder will automatically display the correct format framing and the exposure counter will indicate the number of frames remaining though now for the panorama format. The EC/d also displays a 'P' in the top left of the window.



Ensure you turn the knob as far as it will go to the stop position when selecting the panorama format.



A flashing 'P' in the EC/d together with a locked shutter release indicates that either the format selector knob is not positioned correctly or that you have switched from standard to panorama format when only one standard sized unexposed frame remained on the film.

Exposure Control

Exposure control can be automatic (aperture priority) or manual. Aperture priority means that the camera automatically chooses a shutter speed to match the aperture that you have set. The TTL exposure meter provides a centre-weighted, average reading and measures the light at the shutter plane. A red LED display in the form of symbols inside the viewfinder indicate the exposure reading status. A warning '!' symbol also indicates that the lens cap may still be in place.

The pattern of the sensitive area remains the same for both the normal and panorama formats. It occupies a central area of approximately 20 x 30 mm and is suitable for readings with the camera in both the horizontal and vertical positions. Normal photographic precautions and practices apply when taking an exposure reading in either manual or automatic mode with regard to the tonal value of the chosen metered area, the effect of bright skies in landscapes, the contrast range of the scene, back light situations, etc.

Automatic

29, 30

1. If set within the manual speed range, turn the shutter speed selector dial to align 'A' against the index on the camera body. It will click into position.
2. Press the shutter release button half way to activate the meter.
3. Adjust the aperture setting according to the signals in the viewfinder to ensure the exposure will be within the metering range as in the table.



Ensure you check this information when using automatic mode in case the lighting conditions are beyond the range of the meter/camera settings for the sensitivity of the film in use. This might happen when using a fast film in very bright conditions or a slow film in poor lighting conditions, for example.



In automatic mode, the longest exposure possible is 4 seconds.

Holding the shutter release button half way down will lock the exposure reading. When the shutter release button returns to its normal position, the camera continues to measure light for approximately 10 seconds. The M/d will also show the Tv value (shutter speed) for that particular exposure setting in 1/2 EV steps.

A
U
T
O

(30a)		= beyond metering range (too dark)
(30b)		= calculated exposure time of more than 2 seconds (open the aperture until the ● symbol appears)
(30c)		= correct exposure
(30d)		= calculated exposure time of less than 1/1000 second (close the aperture until the ● symbol appears)
(30e)		= beyond metering range (too light)

M
A
N
U
A
L

(31a)		= beyond metering range (too dark)
(31b)		= more than 1EV underexposure
(31c)		= between 0.5 EV and 1EV underexposure
(31d)		= correct exposure
(31e)		= between 0.5 EV and 1EV overexposure
(31f)		= more than 1EV overexposure
(31g)		= beyond metering range (too light)

1. If set at 'A', depress the shutter speed control lock button. At the same time, turn the shutter speed control to any desired shutter speed except 'A' or 'B' by aligning it against the index. You can then turn the shutter speed control without having to press the lock button again. It remains locked only at the 'A' setting. Be sure to set the dial at a specific speed and not in between two speeds as this will cause exposure errors.
2. Press the shutter release button half way to activate the meter.
3. Adjust the aperture and/or shutter speed controls until the ● symbol appears in the viewfinder for correct exposure, or as in the table.

The M/d will also indicate the Tv (shutter speed) setting. A flashing Tv signal, fig 32, indicates exposure beyond the range of the film.

 in the M/d = *outside exposure range*

In certain situations a preferable exposure may be obtained – technically or creatively – by overriding the suggested exposure. There are two alternative ways to do this in automatic mode, the choice of method depending on the type of scene. Where there are large, bright areas – a landscape with large white clouds for example – point the camera down towards foreground tones and press the release button half way to lock the exposure. While maintaining the pressure on the button, return to the desired composition and press the button all the way down for exposure.

In situations where this method is not possible – there are no suitable areas to make a reading from or where you are taking several pictures in quick succession, for example – use the exposure compensation dial instead. Marked in half EV steps, it will provide you with the desired amount of correction automatically.

For example, if you want to photograph a dark figure against a dominant light background, the exposure suggested (averaged TTL meter reading) will produce an underexposed image. By setting an exposure compensation of + 1.5, for example, the result will be more natural. A common situation is a 'back lit' subject – an interior where a figure is standing in front of a window, for instance, or against snow, a sandy beach, silhouetted against a sky, etc,

where the background is very light while a much smaller but important part of the image is comparatively much darker.

The opposite situation can also be corrected where, for example, a light coloured object is positioned in front of a very dark background. In this case an averaged TTL meter reading will suggest a reading that would produce an overexposed image. A decrease compensation of -1.5, for example, can be applied producing a background tone that was closer to the original and darkening the object to a more 'natural' tone. Similar situations might be an object placed in sunlight against a background in shadow, for example.

The amount of compensation required will differ from case to case dependant on the situation and the desired effect.

 Do not forget to re-set the exposure compensation dial back to zero after use.

 Check regularly that the exposure compensation dial has not been unintentionally changed.

The auto-bracketing function allows you to make a series of increased and decreased exposures in rapid succes-

sion to ensure an optimal exposure without having to alter the settings after each exposure. This is particularly useful when using reversal film that inherently has little tolerance for exposure error. It under- and overexposes (by altering the shutter speed) using the chosen exposure setting as standard providing three separate exposures. Half or full EV step variations can be made. Proceed as follows:

1. Set the film transport mode to 'S' or 'C'.
2. Depress the 'AEB' button located below the M/d panel. The 'AEB' symbol will appear in the square in the M/d (fig.35). '± 0.5' will also appear, replaced by '± 1' if depressed one more time and finally a return to neutral if pressed for a third time. These figures show the amount of exposure variation you can choose from for the three frame sequence.
3. Determine the exposure as normal in manual or 'automatic' mode.
4. Press the shutter release button (or remote release) and keep it pressed until the three frames have been exposed.

The exposures will consecutively be: standard, under, over. They are also indicated in the M/d as follows (assuming 0.5 EV is your choice of variation for this example) :

Exposure #1 displays '± 0.5' (standard)

Exposure #2 displays '-0.5' (under)

Exposure #3 displays '+0.5' (over)

The bracketing function will automatically be deactivated when the camera is turned off and will have to be reactivated when switched on again. The function can also be turned off by pressing the AEB button again.

 If you release the pressure on the shutter release button (or remote release) too soon, the operation will not complete. When depressed again, the sequence will carry on from where it stopped. That is to say, if you release the pressure after the first exposure for example, the two final exposures remain programmed in the camera. Therefore, when you depress the release again (assuming you have not turned off the AEB mode or the camera), the first exposure will be underexposed by 0.5EV and the exposure after that, overexposed by 0.5EV. The information concerning the remaining frames remains in the camera even if it has gone into the standby mode but the AEB symbol and the figures will be visible again in the M/d when the camera is reactivated.



Pay attention to the information in the M/d when working in the AEB mode and try to remember to cancel this mode after use either by pressing the AEB button again or by turning off the camera. Failure to do so can cause frames to be incorrectly exposed as you may have inadvertently continued an interrupted sequence or started a new one.



The standard exposure will include any exposure compensation you have set either by using the exposure compensation dial or via the ISO dial.



The shutter will lock and the M/d will indicate a flashing 'AEB' '±' and a number when the bracketing function is activated if only one or two unexposed frames remain on the film.



The shutter will lock and a flashing 'P' will appear in the EC/d if the format is changed while the camera is set at 'AEB'.



Do not forget to remove the lens cap when making an exposure !

Film advance

The film is advanced automatically to the next frame with consistent spacing between frames regardless of format. This resetting of the frame position can be heard when the format selector is moved.

When the mode dial is set at 'S', one exposure is made. When the mode dial is set at 'C', consecutive exposures are made as long as the release button remains depressed. In the C mode the exposure rate is 3 frames/s in the standard format and 2 frames/s in the panorama format.



If only one unexposed frame is left on the film to cover the standard format and the format selector is switched to 'panorama', the shutter will lock and a 'P' will flash as a warning.

General

LCD illumination

36

When the ambient lighting conditions are too dark to read the LCD information panels, press the LCD back light illumination button located below the M/d panel, as in the illustration. The panels will be illuminated and remain so until the camera remains inactive for a period of five seconds. The lighting will then go out automatically. The button also has a toggle function so you can turn the lighting off simply by pressing button again.

Close-range photography

The viewfinder has an integral parallax compensation facility. This automatically moves the position of the bright frame in the viewfinder in accordance with the focusing distance to ensure correct framing of the subject.

Film plane index

The film plane index is situated on the top plate of the camera to the left of the flash hot shoe. This provides the most accurate mark for distance measurement from the subject.

Self timer

37, 38

1. Set the main selector dial to the self timer icon as in the illustration.
2. A self timer icon appears in the M/d panel.
3. Press the shutter release button.
4. The self timer lamp, located on the front of the camera to the right of the viewfinder window, lights up for seven seconds and flashes for three seconds as a countdown indication.
5. The shutter will then fire, the film will advance and the self-timer will be reset.

Even if the self-timer operation has started, you can stop it simply by turning the mode switch back to 'S' 'C' or 'OFF'.



When set in the automatic mode, do not stand in front of the camera when pressing the release button as this could adversely affect the exposure reading.



The exposure reading is fixed at the time of pressing the shutter release button, even in AE mode. Check, therefore, to see that there has been no change in the lighting conditions during the ten second delay before exposure.

Infrared photography

39

Infrared (IR) rays (wavelengths longer than 800 nm) form an image on a plane further away from the lens than the image plane for visible light. To compensate for this difference you have to align the chosen distance against the red IR index and not the normal central index. Proceed as follows:

1. Focus as usual.
2. Note the distance on the focusing scale that is opposite the central index line on the lens.
3. Now rotate the focusing ring to set this distance opposite the red IR index spot instead of the central index line.

The illustration shows a lens focused at approx. 4 metres for infrared film. See specific film instruction leaflet for details of filters, film storage, handling and development.



Please make tests with your choice of infrared film before use. High speed black and white infrared film, for example, can be slightly fogged on the edge of the film frame by the film transport emitter/sensor system.

Flash

40

There is flash sync at all speeds from B to 1/125 via the PC flash socket or hot shoe connector. Please see your flash unit's user manual for further information.

When the panorama format is selected, the flash should be adjusted to cover the field of view. With the 45 mm lens you should choose an angle that would normally be suitable for a 25 mm lens in the 35 mm format. With the 90 mm lens you should choose an angle that would normally be suitable for a 50 mm lens in the 35 mm format.

Cable release

41

A variety of remote releases can be attached to the XPan which has a standard cable release port. Any type of release is suitable on condition that the final connector is mechanical and standard, as in the illustration.

The use of a cable release activates the camera (including the exposure meter) and fires the shutter immediately. In Auto mode you can see what shutter speed was chosen by the camera on the M/d; in Manual mode press the shutter release button half way to activate the exposure meter and adjust the settings before making an exposure with a cable release.



When the shutter speed is set at 'B', the drain on the batteries is substantial. The maximum exposure time at this setting is 270 seconds.

Mid-roll rewind

42

Normally the film is automatically rewound into the cassette after the last frame has been exposed. To remove the film beforehand, however, you must press the mid-roll rewind button located below the M/d panel. The button is recessed to prevent unintentional use, so use the tip of a ball-point pen or similar to access it.

Exposure history

The total number of exposures taken with the camera can be checked on the M/d. With the camera turned off, depress the AEB button and keep it depressed while you switch the shooting mode selector to 'S'.

Each unit signifies ten exposures. You may find that even a brand new camera indicates around 200 exposures taken. This is a result of testing during manufacture and is not a sign of used equipment.

This facility is a handy check to see whether the camera should be serviced.

If you have panorama format exposures or a mixture of standard and panorama format exposures on the same roll of film, be sure to use a film processing laboratory that is aware of the situation and is qualified to handle such cases. Normal consumer film processing facilities are not suitable as their systems cannot allow for the mix of formats and will cut the film incorrectly. Films containing only standard format images, however, remain unaffected and you may use a normal consumer lab.

The lab stickers are provided as a convenient way of informing or reminding the film lab of the situation. Ensure that the sticker covers the film type bar code and the DX code strip on the cassette. Additional stickers are available from your Hasselblad dealer. You may of course mark the cassettes very clearly in some other way to ensure that the film is cut manually.



Always check with the laboratory first to avoid problems.

Further information about panorama format printing and the location of suitable processing labs can be obtained from your local Hasselblad dealer.

Accessories

The XPan is supplied with a front protective cap, a Quick-coupling plate XPan (together with a hex wrench/Allen key and fixing bolt), a spirit-level and a strap. At the end of this manual you will find a list containing the optional accessories available for the XPan, some of which are described below. Various flash guns can be attached to the hot shoe and flash brackets can be attached via the tripod screw on the baseplate. Remote releases – cable, pneumatic or electric – can be attached via the cable release socket.

Quick-coupling plate

The Quick-coupling plate XPan (44408) allows you to use the Hasselblad Tripod quick-coupling S (45144) – an optional accessory available from the conventional Hasselblad range – for rapid and secure attachment to a tripod and is only necessary for use in this case.

The plate is supplied together with a fixing bolt and a hexagonal 'Allen key' wrench. Align the plate along the length of the camera's baseplate and screw the bolt

clockwise into the tripod socket a few turns. Ensure the alignment pin on the plate matches its respective socket in the camera baseplate and continue to screw the bolt until it is securely attached.

Spirit-level

44, 45

The dual-directional spirit-level simply fits into the flash hot-shoe and provides a check for both horizontal and vertical photography. This can be particularly useful when photographing buildings, for example. In these cases the use of a tripod or stable camera support is particularly recommended.

Ensure, however, that it is fitted correctly; see illustrations. Note the difference depending on whether the camera is in the horizontal or the vertical position. Check that the spirit-level has been pushed all the way into the shoe as far as it will go. Remember that the spirit level is intended to be an aid in levelling and cannot guarantee complete accuracy. Check the image carefully in the viewfinder.

UV-Sky filter

The UV-Sky filter XPan (54460) is designed for use with the Hasselblad 4/45mm and the Hasselblad 4/90mm lenses. The filter absorbs some of the ultra-violet rays

present in light which cause the appearance of haze, particularly noticeable in photography at high altitudes, for example. The use of a UV-Sky filter can reduce this effect somewhat and also cause a slight warming of tone on colour film.

The filter can safely be left on the lens for most photographic applications as it provides some protection for the lens' front element not only against dust and rain etc but also against scratches and accidental damage.

The filter is multi-coated to ensure high anti-reflection quality. No degradation in MTF is seen and there is no shift in focus.

Centre filter XPan for 45mm

The Centre filter XPan for 45 mm (54453) is designed for use mainly with the Hasselblad 4/45-mm lens (24015).

The 45 mm lens is free from vignetting with panorama format images at lens aperture settings smaller than f/8. However, natural light fall-off (a basic law of physics) reduces the exposure at the corners of the image by roughly 1 f-stop.

This light fall-off at the corners causes visible effects in critical photography when using transparency film. When using negative film, however, natural light fall-off present in traditional optical printing set-ups (most

film labs and mini-labs) automatically compensates for this to a greater extent in the print. Therefore, when using negative film and with the lens stopped down, there may be no need to use a centre filter.

The only way to eliminate light fall-off at the corners is to reduce the amount of exposure at the centre of the image. The Centre filter XPan works by a concentration of neutral density at the centre and a progressive reduction of density towards the outer edge. The effect at the centre of the filter corresponds to a 1 f-stop reduction in exposure.

The filter is multi-coated to ensure high anti-reflection quality. No degradation in MTF is seen and there is no shift in focus.

Tips & Reminders

- Photographers normally used to working with SLR cameras should particularly check that the lens cap has been removed when making exposures. A flashing red warning appears in the viewfinder.
- Take care if using other types of lens shade or filter holders. As the XPan does not have a TTL viewing system it will be difficult to judge effects and possible vignetting. They may also obscure the rangefinder optics and cause visual focusing difficulties through the viewfinder.
- Regularly check that the controls are set correctly before you take a photograph. For example, you may have set the camera at ASA/ISO override for a previous film and have forgotten to reset the Auto DX code setting. Or perhaps you have inadvertently moved the exposure compensator dial or forgotten to reset it.
- When using the panorama format, ensure that you compose accurately, or at least allow a margin for error. If you decide to crop an image later, to level a horizon for instance, you may be forced to mask off slightly more than normal compared to a similar correction in the standard format, owing to the panorama format's greater length.

- If you open the camera back by mistake before you have finished the film, you will only have lost the last exposed frame and the unexposed frames. The exposed frames have already been wound back into the cassette as the XPan starts by withdrawing all of the film first and progressively rewinding it frame by frame.
- Make a habit of turning off the camera when not in use. The power save function will put the camera in stand-by mode automatically after three minutes of inactivity but it may reactivate if something presses against it; in a camera bag for example.
- Check battery status regularly and always keep some spare batteries in your camera bag.
- At very low temperatures, the batteries may not provide sufficient power for the camera. Keep some spare batteries in your pocket, for example, to keep them warm. These can then be exchanged and be used alternately while the cold batteries are being warmed.
- The dependable working range for the camera is -10°C – $+40^{\circ}\text{C}$.
- The LCD's may look dark at temperatures around 60°C and react slowly at very low temperatures. This is quite normal and does not signify a fault.
- When using using a combination of the 45mm lens, panorama format and transparency film, the natural

light decrease appears as slight light fall-off for critical applications. This is quite natural and is not due to lens vignetting for a stopped-down lens. To minimize this effect use an aperture of f/8 or smaller and avoid under-exposure. The effect can be completely eliminated by using the Centre filter XPan for 45mm (54453).

- Remember that it is roughly the central 20 x 30 mm area that is used in light metering. This is particularly important when using the panorama format if the scene contains a wide range of lighting or tonal contrasts.
- When objects are very close to the lens, remember that their position in relation to the background will also be subject to parallax and therefore, dependent on distance, will not be exactly as seen in the viewfinder. This effect is mainly of concern with the 30mm lens.
- Landscapes can often include a great deal of sky in wide-angle photography. If pale in tone or with large white clouds for example, such skies can affect the exposure meter sufficiently to cause under-exposure of the image. Dependant on the desired effect, take an exposure reading from a more appropriate part of the subject, excluding most of the sky, or use an external exposure meter.

Viewfinder eyepiece selection

The table below provides the choice of correction eyepieces available in connection with an eyeglass prescription. Firstly, decide which eye you would normally use for viewing. Then check your prescription bearing in mind that in ophthalmic terms O.D stands for the right eye and O.S stands for the left eye. In the table, read off the appropriate eyepiece that is alongside your prescription figures.

If your cylindrical eyeglass prescription is more than 0.5 dioptres, it is recommended that you always wear your eyeglasses for viewing and focusing.

Please note that the eyepiece, including the correction glass holder, is constructed from a plastic material to minimise the risk of scratching eyeglass lenses.

Ophthalmology prescription SPHERICAL	Recommended eyepiece	
	Power	Code no.
+ 3.0 - + 2.5	+ 2	54436
+ 2.25 - + 1	+ 0.5	54433
+ 0.75 - - 0.5	- 1 (std)	54439
- 0.75 - - 1.5	- 2	54430
- 1.75 - - 2.5	- 3	54427
- 2.75 - - 3.75	- 4	54424

Troubleshooting

Your XPan is a fully professional camera and should provide many years of service particularly if the advice is followed under 'Equipment Care, Service and Guarantee'. If a problem arises, however, check back in this manual to the relevant section first taking particular note of the specific warnings. Then check the table below to see if you can solve it. Refer to a Hasselblad Authorised Service Centre if the problem persists.

Problem	Possible cause / solution
Camera does not react when the release button is pressed.	<ul style="list-style-type: none">• Mode selector in 'OFF' position.• Batteries omitted or exhausted.
You cannot attach the lens.	<ul style="list-style-type: none">• Ensure lens indexes are aligned.
You cannot remove the lens.	<ul style="list-style-type: none">• Depress lens release button while turning lens.
New film has not wound on to first frame.	<ul style="list-style-type: none">• Film tip incorrectly positioned before closing camera back.• ISO setting at DX position with a non-DX coded film cassette.
Whole film under/overexposed.	<ul style="list-style-type: none">• Manual film speed (ISO) dial set incorrectly.• Exposure compensation dial not set at zero.
Some frames unexposed.	<ul style="list-style-type: none">• Lens cap not removed.

Technical Specifications – XPan

Camera type:	Coupled rangefinder with interchangeable lenses.
Design:	Aluminium and titanium camera body.
Viewfinder:	Bright frame viewfinder (ambient light), automatic parallax compensation, automatic standard/ panoramic switch over via format selector dial, automatic bright frame switch-over according to lens fitted, integral LED exposure metering indications. Field of view 85% or more.
Focusing:	Lens helicoid interlocked to coupled rangefinder.
Film transport:	Pre-wind type, automatic positioning according to format, automatic wind-on, automatic rewind. Single-frame and continuous.
Film type:	35 mm
Format:	24x36 mm and 24x65 mm.
Frames per film:	36, 24 and 12 frames in standard format or 21, 13 and 6 frames in panorama format from 36 exp, 24 exp and 12 exp cassettes respectively.

Exposure counter:	LCD. Automatic, shows number of frames remaining. Illuminated. Panorama format indication.
Shutter:	Focal plane shutter, B (max 270s) – 1 / 1000 s, flash synchro from B – 1/125 s. Activated by button or cable release socket. 1EV step control on manual, 1/12 EV step control on automatic, self-timer with 10 s delay.
Exposure control:	TTL measured at shutter plane, centre weighted averaging system, aperture priority automatic/ manual switch over, $\pm 1/3$ EV accuracy, 4EV(f 4) – EV19(f 22) (ISO 100).
Exposure compensation:	± 2 EV at 1/2EV step intervals.
Auto bracket:	0.5EV or 1.0EV step intervals. Order: standard, under, over.
Film speed:	Auto DX setting and manual setting. ISO25 – 3200 sensitivity.
LCD information:	Illuminated. ISO, Tv, Auto bracket, self-timer, battery check, total exposure counter.
Batteries:	CR2 x 2 (6v total).
External dimensions:	Camera body only: 51 mm L x 166 mm W x 82 mm H. (2.04 x 6.64 x 3.28") 45 mm lens: 47 mm L (1.88"), \varnothing 60 mm. 90 mm lens: 73 mm L (2.92"), \varnothing 60 mm.

Weight:

Body only: 720 g (25.2oz) without batteries. 30 mm lens : 310 g (10.85oz).
45 mm lens: 235 g (8.23oz). 90 mm lens : 365 g (12.78oz).

Lenses:

Hasselblad 5.6/30 mm Aspherical lens:
bayonet fitting, f 5.6 – f 22, 8 components, 10 elements, focusing range 0.7 – ∞ m, filter Ø58 mm. Angle of view-diag./hor.72°/62°(standard format) 98°/94° (panorama format) ≈17 mm lens in 35 mm camera terms when camera set at panorama format.

Hasselblad 4/45 mm lens:
bayonet fitting, f 4 – f 22, 6 components, 8 elements, focusing range 0.7 – ∞ m, filter Ø49 mm. Angle of view-diag./hor.51°/47°(standard format) 74°/71° (panorama format) ≈25 mm lens in 35 mm camera terms when camera set at panorama format.

Hasselblad 4/90 mm lens:
bayonet fitting, f 4 – f 22, 7 components, 9 elements, focusing range 1.0 – ∞ m, filter Ø49 mm. Angle of view-diag./hor.27°/23°(standard format) 42°/40° (panorama format) ≈50 mm lens in 35 mm camera terms when camera set at panorama format.

Equipment Care, Service and Guarantee

EQUIPMENT CARE

The Hasselblad XPan is designed to withstand the rigours of professional use in most environments. To avoid the possibility of damage however, it should be protected from the following:

Extremes of temperature. High temperatures can have an adverse effect on both film and equipment. Try to avoid frequent and severe temperature changes. Be particularly careful in humid environments. Corrosion of electrical contacts may occur in these situations if sufficient care is not taken. Allow the equipment to acclimatize before disassembly. Try to ensure the storage conditions in such environments are as dry as possible.

Dust and grit. You should take care to prevent dust and grit from getting into your equipment. In coastal areas take measures to protect your equipment from sand and salt water spray. Dust on the lens glass can be removed with a blower brush or very soft lens brush if necessary. Smears on the lens glass should be treated with great caution. In some cases they may be removed with a high quality lens cleaning solution on a tissue but be careful not to scratch the lens or touch any of the glass surfaces with your fingers. If in any doubt, do not attempt to clean lens

glass surfaces yourself but allow a "Hasselblad Authorized Service Center" to treat them.

Impact. Your equipment can be damaged by severe physical shocks so practical protective precautions should be taken. When not in use, try to make a habit of storing your camera equipment in some form of protective case or bag to avoid accidental damage.

Loss. Hasselblad equipment is much sought after and you should take obvious steps to prevent theft. Never leave it visible in an unattended car, for example. Separate and specific camera insurance cover should be considered by professional users.

SERVICE

You should return your equipment to a service centre for occasional checking and preventive maintenance to ensure optimal reliability. If your camera is used constantly and intensively, periodic check-ups every six months are recommended at one of the "Hasselblad Authorized Service Centers". They have the expert staff and specialised equipment necessary to ensure that your equipment remains in perfect working order.

GUARANTEE

Provided that you bought your equipment from an authorised Hasselblad outlet, it is covered by an international guarantee for one year. The guarantee document and a registration card are supplied with the camera. Keep the guarantee document carefully, but fill in the registration card and return it to your Hasselblad distributor.

<u>HASSELBLAD XPAN CAMERA</u>	14010
<i>supplied with the following equipment:</i>	
Front protective cap, XPan	54415
Quick-coupling plate, XPan (with hex wrench)	44408
Strap, XPan	54403
Spirit-level, XPan	54418
Batteries (2 x CR2)	

<u>HASSELBLAD XPAN KIT</u>	14450
<i>Complete camera with supplied equipment as 14010, plus Hasselblad 4/45 mm lens (complete with supplied equipment as 24015) plus Lens shade, XPan 54406.</i>	

<u>HASSELBLAD 5.6/30 MM ASPHERICAL LENS</u>	24013
<i>supplied with the following equipment:</i>	
Viewfinder XPan 30 mm	54472
fitted with a 'neutral' correction lens	54482
Lens shade XPan 30 mm	54407
Centrefilter XPan for 30 mm	54451
Lens pouch	58408
Viewfinder pouch XPan 30 mm	54463
Front lens cap for XPan	54410
Rear lens cap XPan	54412

OPTIONAL ACCESSORIES – XPAN 30

Correction lens, XPan 30, – 4	54476
Correction lens, XPan 30, – 2.5	54479
Correction lens, XPan 30, – 1 (neutral)	54482
Correction lens, XPan 30, + 0.5	54485
Correction lens, XPan 30, + 2	54488

<u>HASSELBLAD 4/45 MM LENS</u>	24015
<i>supplied with the following equipment:</i>	
Front lens cap, XPan	54409
Rear lens cap, XPan (integral)	54412
Protective lens cover, XPan	54421

<u>HASSELBLAD 4/90 MM LENS</u>	24019
<i>supplied with the following equipment:</i>	
Front lens cap, XPan	54409
Rear lens cap, XPan (integral)	54412
Protective lens cover, XPan	54421

OPTIONAL ACCESSORIES

Lens shade, XPan (for 45 and 90 mm)	54406
Centre filter XPan for 45 mm	54453
UV-Sky filter XPan	54460
Correction lens, XPan, – 4	54424
Correction lens, XPan, – 3	54427
Correction lens, XPan, – 2	54430
Correction lens, XPan, – 1 (neutral)	54439
Correction lens, XPan, +0.5	54433
Correction lens, XPan, +2	54436

Catalogue no:

14010
14450

Hasselblad reserve the right to make changes in the published specifications without prior notice.

All rights reserved. No part of this material may be reproduced, stored in a retrieval system, or transmitted, in any form or by any means, electronic, mechanical, photocopy, recording, or otherwise, without the prior written permission of the company.

Copyright © 2000, Victor Hasselblad AB



H A S S E L B L A D

Victor Hasselblad AB
Box 220, SE - 401 23 Göteborg, Sweden
www.hasselblad.com

HASSELBLAD

XPAN

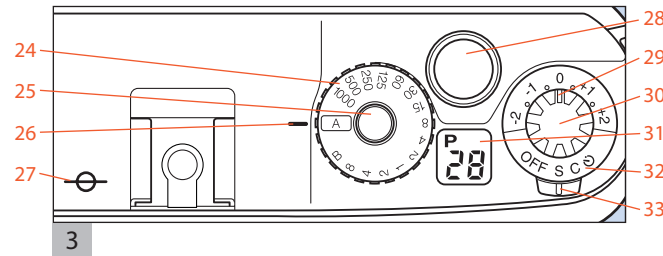
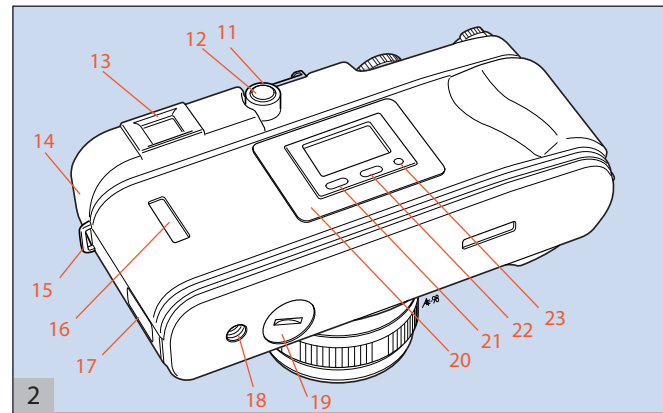
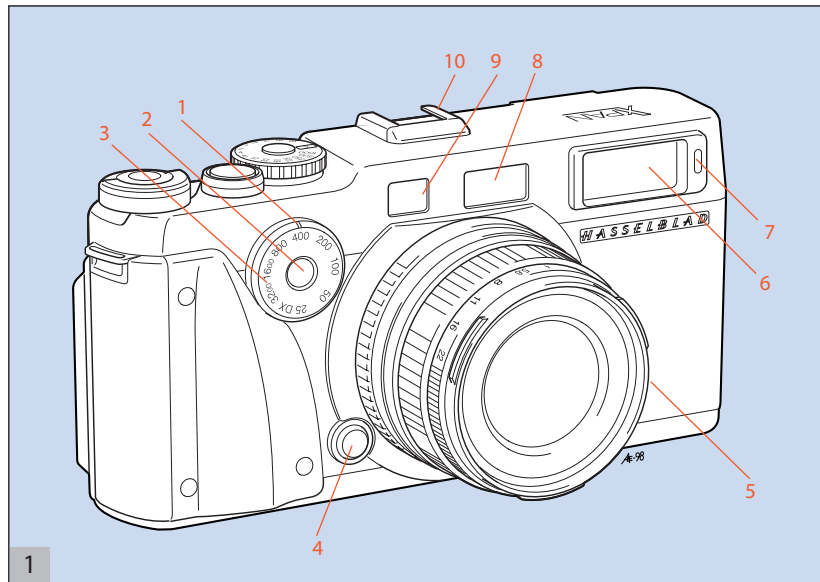

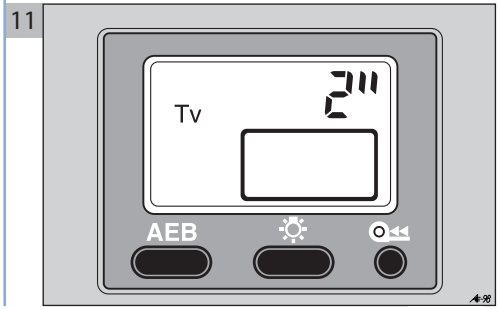
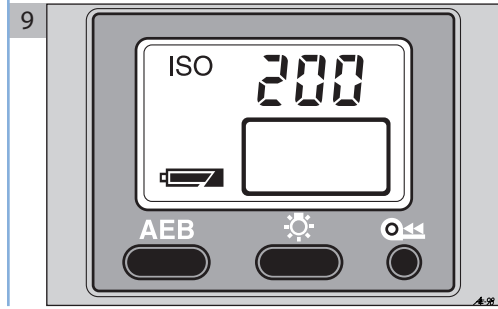
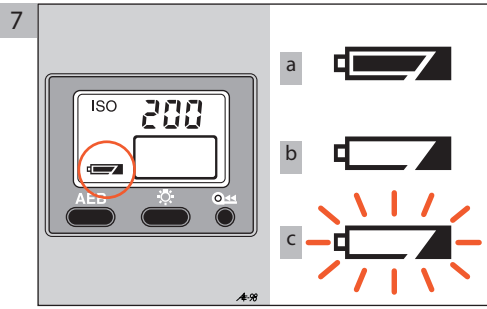
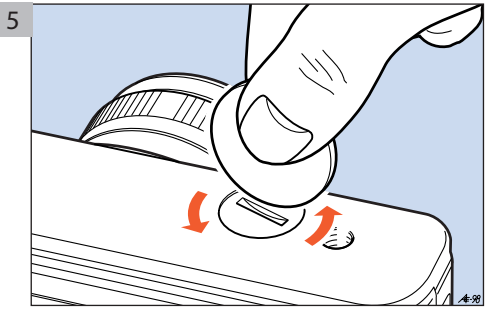
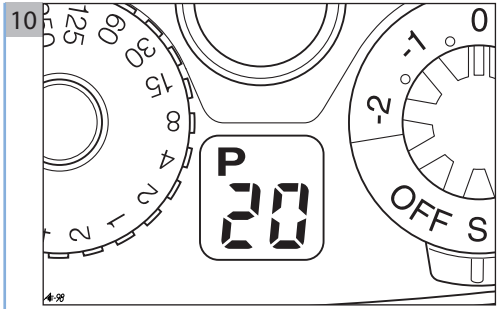
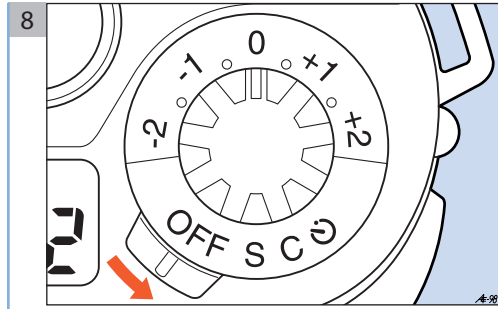
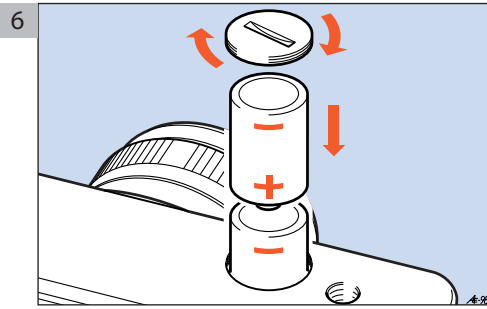
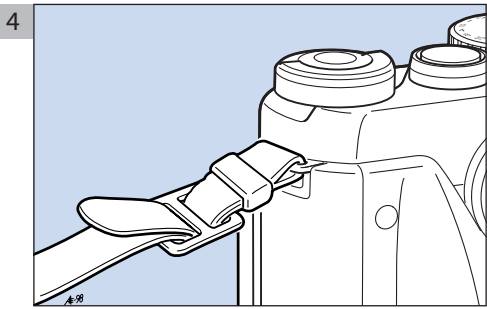

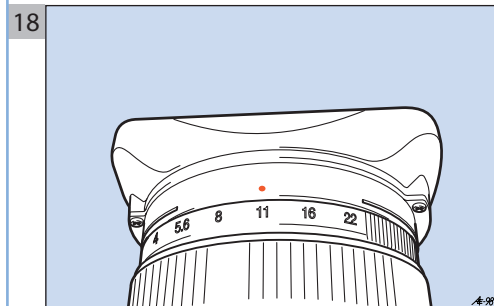
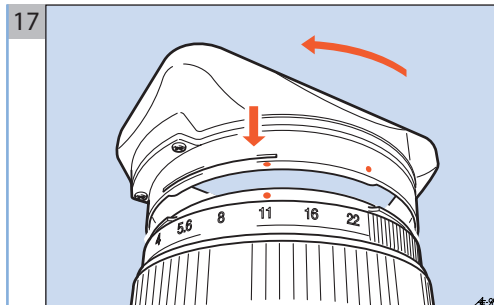
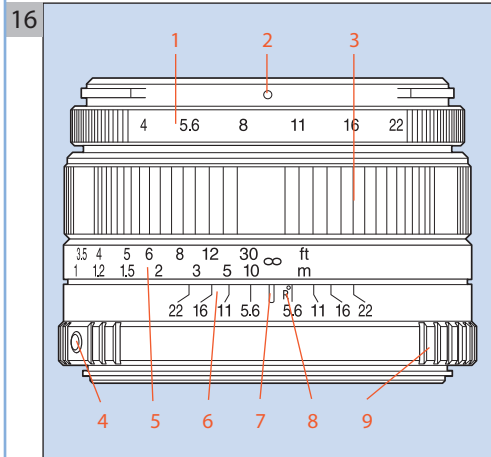
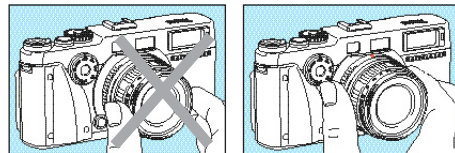
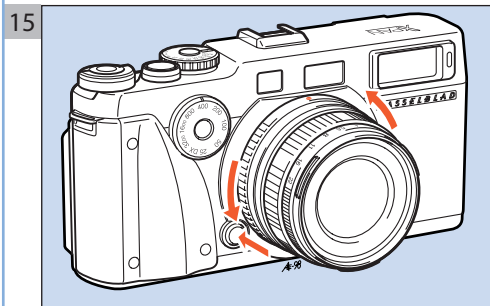
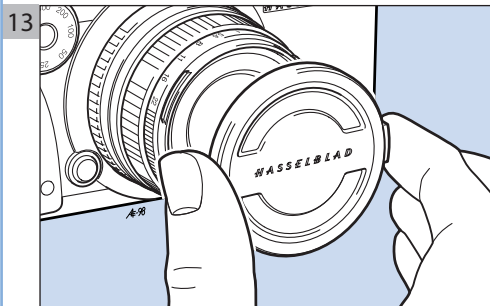
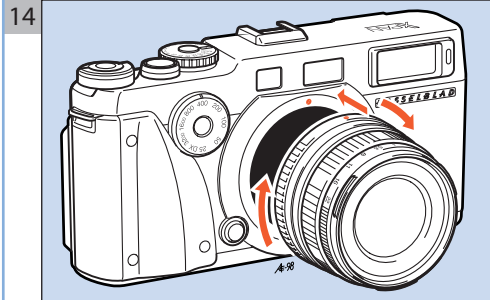
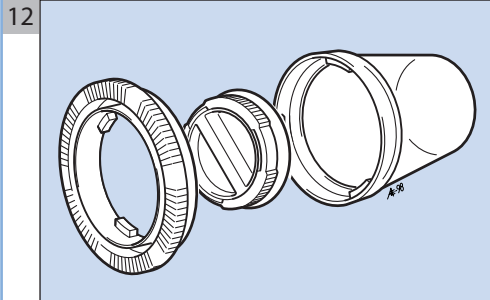

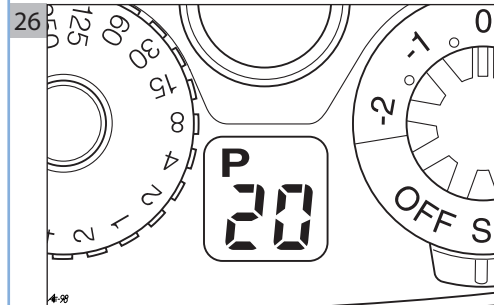
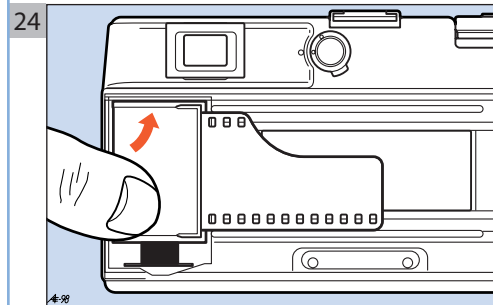
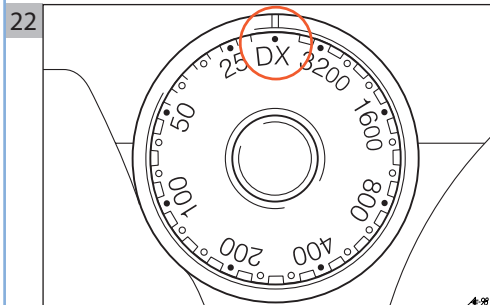
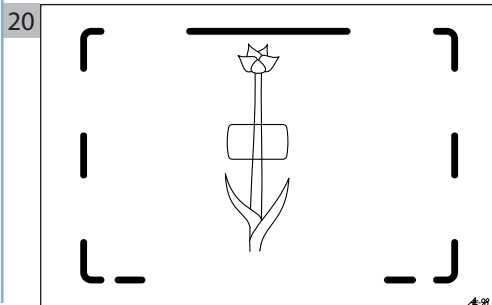
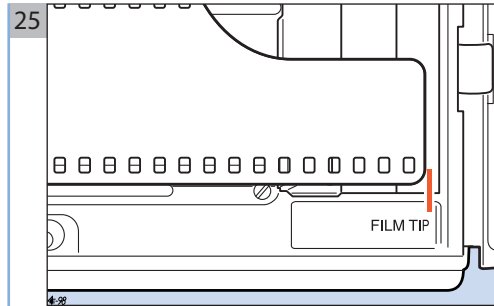
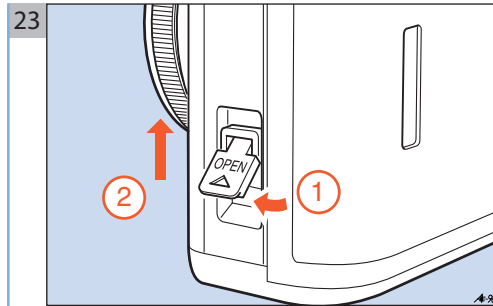
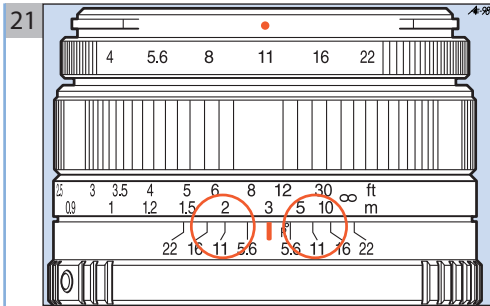
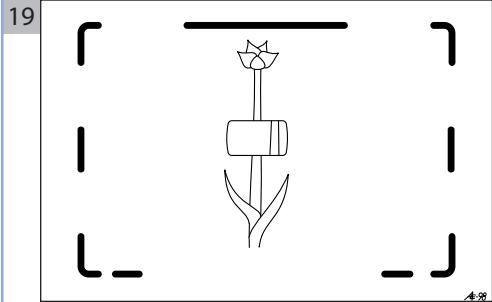

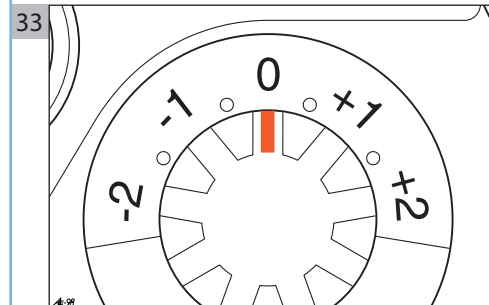
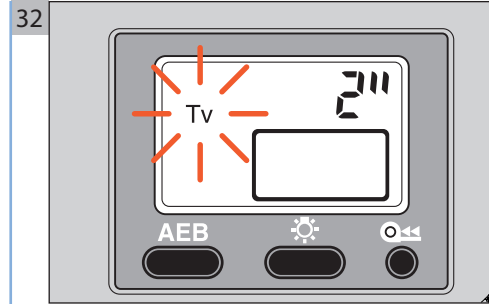
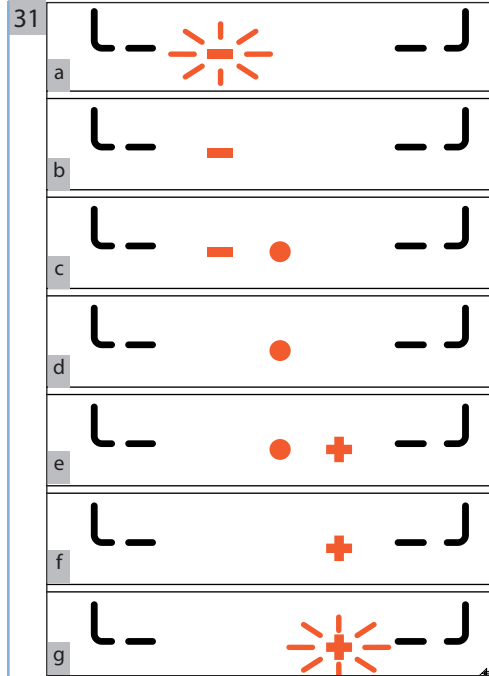
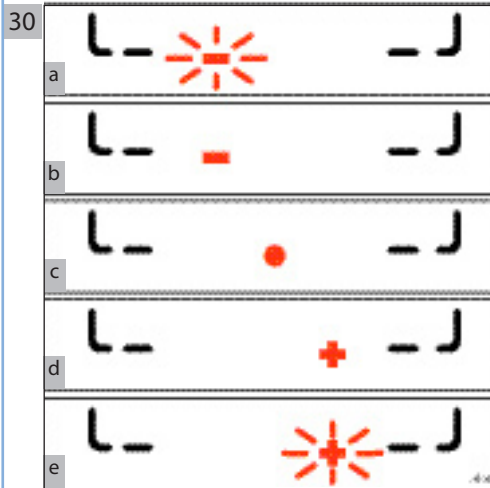
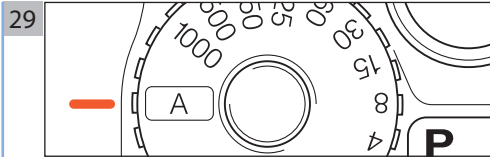
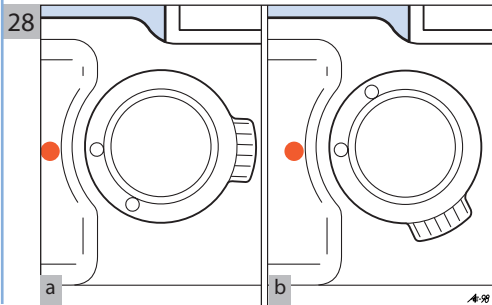
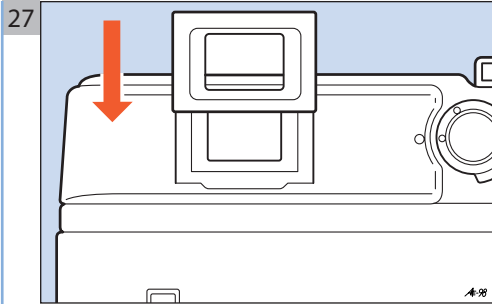

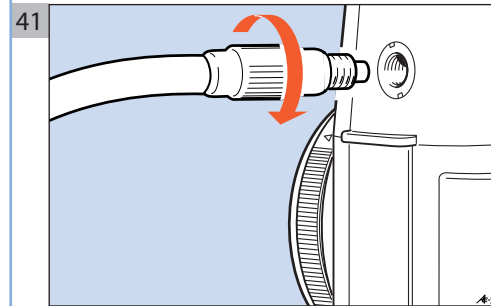
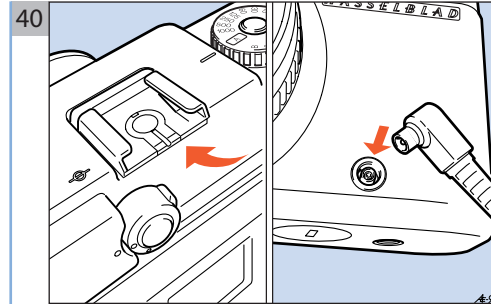
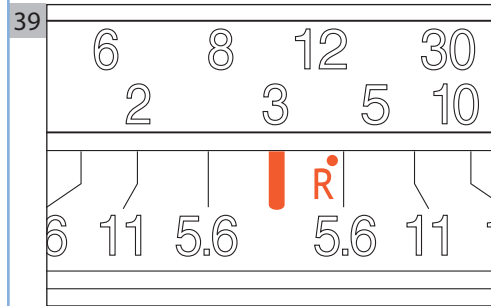
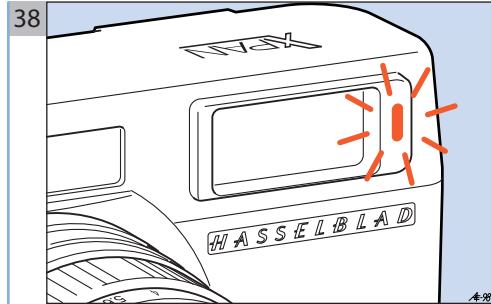
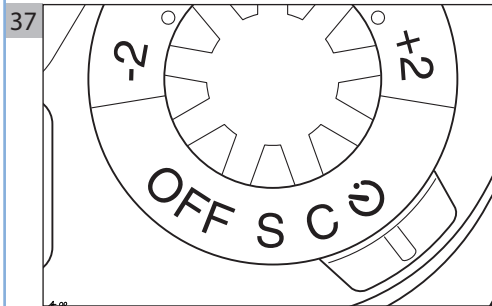
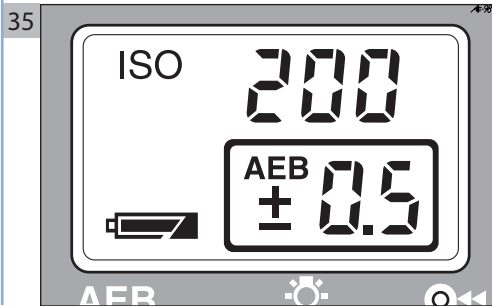
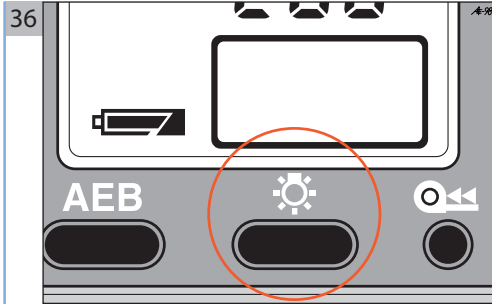
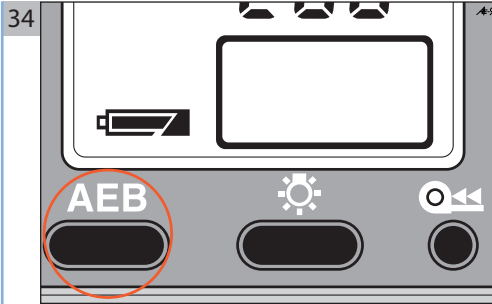

42

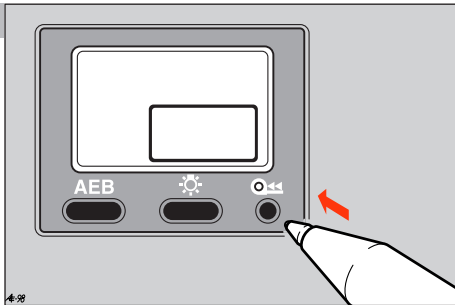

43

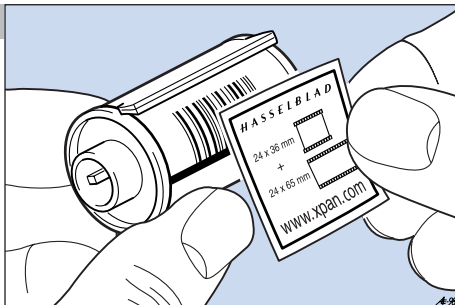

44

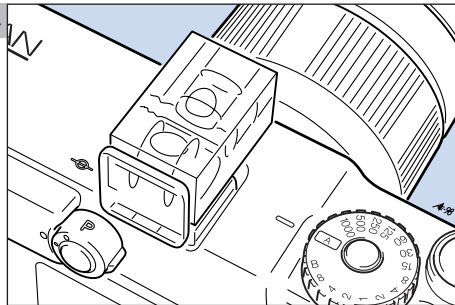

45

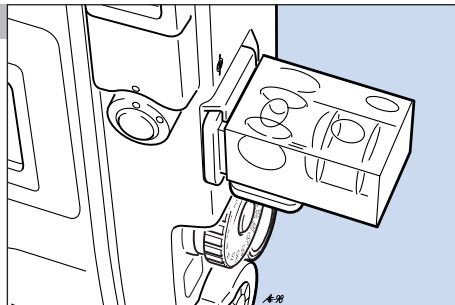

		0.7 m	0.8 m	1.0 m	1.2 m	1.5 m	2.0 m	3.0 m	5.0 m	10 m	∞
Hasselblad 4 / 45 mm	f 4	0.67–0.73	0.77–0.84	0.95–1.06	1.12–1.29	1.38–1.65	1.78–2.28	2.53–3.70	3.79–7.35	6.09–28.3	15.3–∞
	f 5.6	0.66–0.74	0.75–0.85	0.92–1.09	1.09–1.33	1.33–1.72	1.70–2.42	2.37–4.10	3.45–9.14	5.24–∞	10.9–∞
	f 8	0.65–0.76	0.73–0.88	0.90–1.13	1.05–1.40	1.27–1.83	1.61–2.66	2.18–4.83	3.06–13.9	4.39–∞	7.71–∞
	f 11	0.63–0.79	0.71–0.92	0.86–1.20	1.00–1.51	1.20–2.02	1.49–3.09	1.96–6.50	2.64–56.0	3.57–∞	5.47–∞
	f 16	0.61–0.83	0.68–0.98	0.81–1.31	0.94–1.69	1.11–2.37	1.35–4.00	1.72–12.7	2.22–∞	2.82–∞	3.89–∞
	f 22	0.58–0.90	0.64–1.08	0.76–1.50	0.86–2.03	1.00–3.14	1.19–6.92	1.47–∞	1.81–∞	2.19–∞	2.76–∞
Hasselblad 4 / 90 mm	f 4			0.99–1.01	1.18–1.22	1.47–1.53	1.94–2.06	2.87–3.15	4.63–5.43	8.61–11.9	59.8–∞
	f 5.6			0.98–1.02	1.17–1.23	1.45–1.55	1.92–2.09	2.81–3.21	4.49–5.64	8.14–12.9	42.5–∞
	f 8			0.97–1.03	1.16–1.24	1.44–1.57	1.89–2.13	2.74–3.31	4.31–5.95	7.56–14.8	30.2–∞
	f 11			0.96–1.04	1.14–1.26	1.41–1.60	1.84–2.19	2.65–3.46	4.08–6.47	6.87–18.5	21.5–∞
	f 16			0.95–1.06	1.12–1.29	1.38–1.65	1.78–2.28	2.53–3.70	3.80–7.37	6.09–28.8	15.3–∞
	f 22			0.93–1.09	1.09–1.33	1.33–1.72	1.71–2.42	2.38–4.10	3.46–9.20	5.25–136	10.8–∞