

www.butkus.us

Mamiya NC1000

Instructions

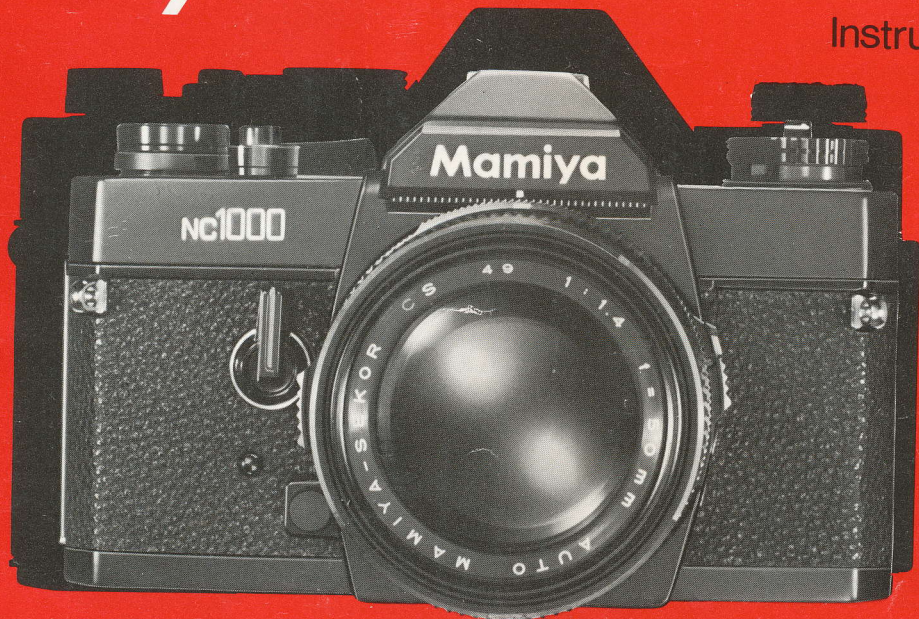

The Mamiya NC 1000 is an innovative 35mm bayonet-mount automatic SLR camera which has been developed with Mamiya's superior technology and long experience as a leading manufacturer of professional medium-format cameras.

This new camera offers the ultimate in handling ease because of its compact size and light weight. Moreover, the open-aperture metering system assures that the large, brilliant viewfinder always remains bright, and the exposure automation system is of the popular shutter-speed priority type, in which the camera meter automatically selects the correct aperture in accordance with the shutter speed selected by the user.

The NC 1000 is designed to meet the needs of the amateur and professional photographer alike. To further enhance its remarkable capabilities, a wide range of accessories are available including an adaptor which allows stop-down metering and diaphragm automation with the TL, DTL, SX series and other universal thread (42mm) mount lenses.

Every care has been taken to assure that your Mamiya camera will provide you with years of trouble-free service. However, to avoid possible mishandling, be sure to read this instruction manual carefully before using your new camera.

Contents

www.butkus.us

Nomenclature	1
Outline of Automatic Exposure (AE) operation	3
Inserting Batteries	5
Battery Check and Exposure Meter Switch	6
Loading Film	7
Setting the Film Speed	9
Setting the AE Button	9
Setting the Shutter Speed	10
Focusing	11
Determining of Correct Exposure	12
Holding the Camera Correctly	13
Unloading the Film	14
Using the Self-Timer	15
Using Flash	16
Interchanging Lenses	18
Advanced Technique	
Depth-of-Field	20
Manual Exposure	21
Correct Exposure in Unusual Lighting	21
Using Infrared Film	23
Stopped-Down Metering	24
Multiple-Exposures	25
Mamiya-Sekor CS Lenses	26
Accessories	27
Care of the Camera	32
Specifications	33

Nomenclature

1. Exposure Counter
2. Meter OFF Button
3. Film Advance Lever
4. Shutter Release Button
5. Hot-Shoe with Safety Cover
6. Film Plane Reference Mark
7. Film Rewind Knob and Back Cover Release

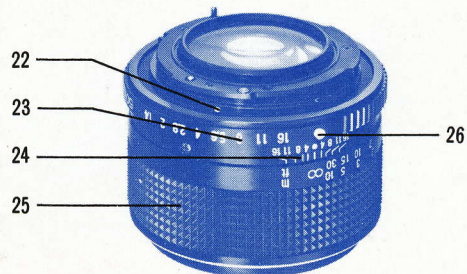
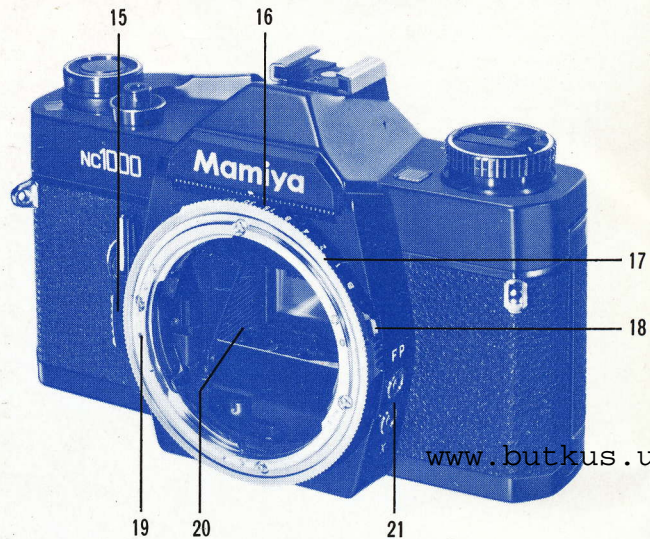
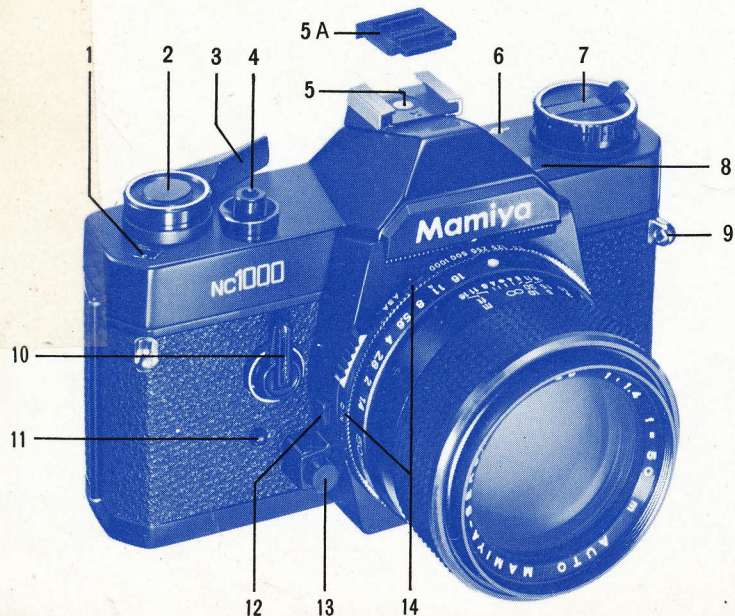

- | | | |
|-----------------------------------|--------------------------------------------|----------------------------------------------------------|
| 8. Battery Check Lamp | 15. Shutter Speed Ring Flange | 22. Alignment Dot for Lens Mounting (lens) |
| 9. Neck Strap Eyelet | 16. Shutter Speed Ring | 23. Aperture Ring |
| 10. Self-Timer Lever | 17. Film Speed Ring | 24. Depth-of-Field Scale and Central Index Mark (orange) |
| 11. Self-Timer Activating Button | 18. Film Speed Ring Lock Button | 25. Focusing Ring |
| 12. Lens Release Button | 19. Alignment Dot for Lens Mounting (body) | 26. AE Button |
| 13. Depth-of-Field Preview Button | 20. Mirror | 27. Battery Check Button |
| 14. ASA/DIN Windows | 21. Flash Sync Terminals (X and FP) | |

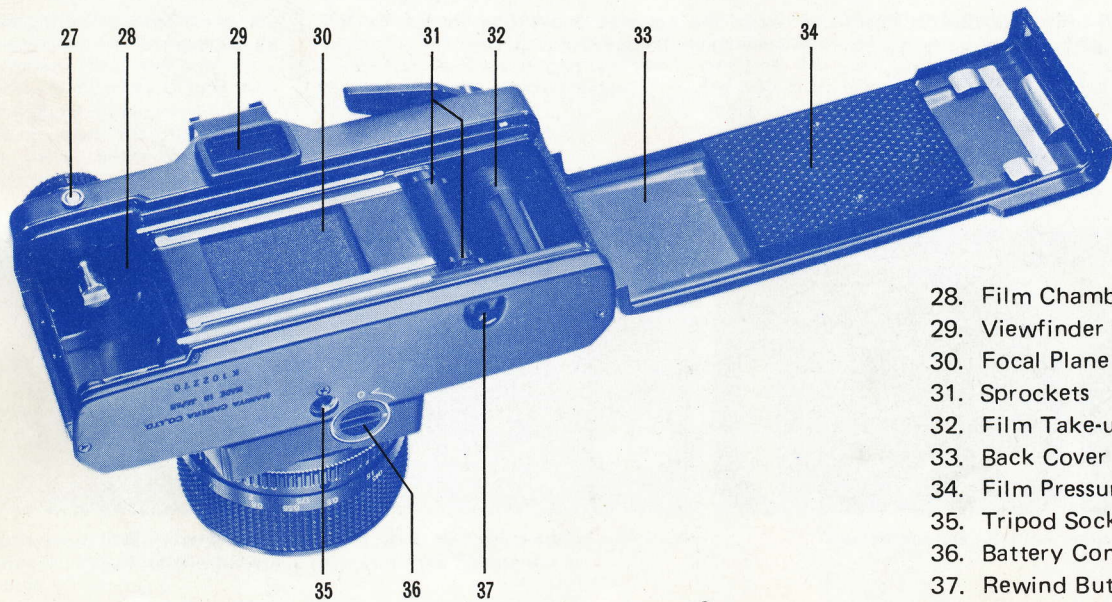

- 28. Film Chamber
- 29. Viewfinder Eyepiece
- 30. Focal Plane Shutter
- 31. Sprockets
- 32. Film Take-up Spool
- 33. Back Cover
- 34. Film Pressure Plate
- 35. Tripod Socket
- 36. Battery Compartment Cover
- 37. Rewind Button

Outline of "AE" (Automatic Exposure) Operation

The procedure appearing below in sketch form is designed for future use to serve as a quick review of the operating procedure which is explained in detail on the following pages. It is also designed for immediate reference by those already well acquainted with sophisticated 35mm SLR's.

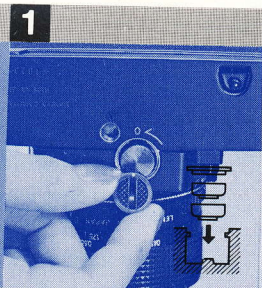

1 Insert the batteries and check voltage by pushing the Battery Check Button.

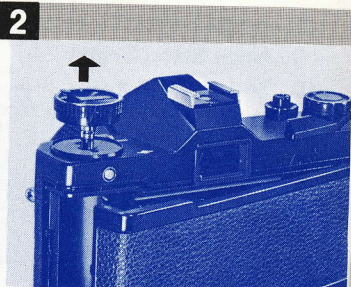
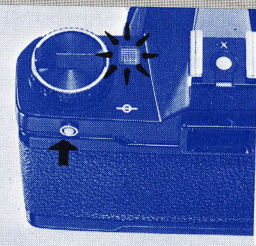

2 Lift up on Rewind Knob to open Back Cover.

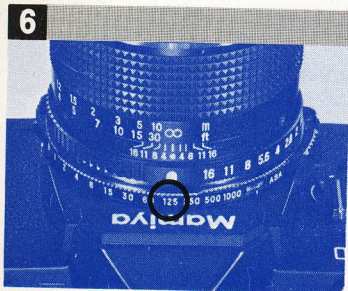

6 Set the appropriate Shutter Speed behind the Central Index Mark.



7 Focus the lens.

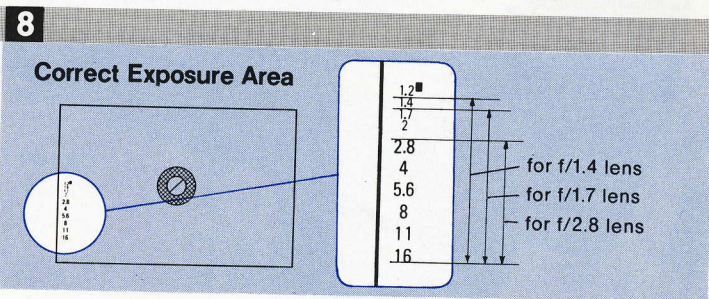

8 Check to see that the Indicator Needle lies in the correct exposure area in the viewfinder.

3

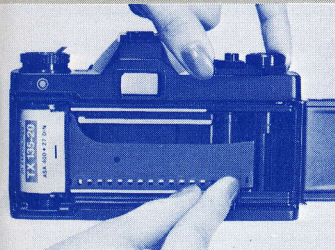

Load film and insert the tip of the film leader into the Take-up Spool and advance film with the Film Advance Lever, making sure that both the upper and lower Sprockets are engaged in the film perforations before firmly closing the Back Cover.

4

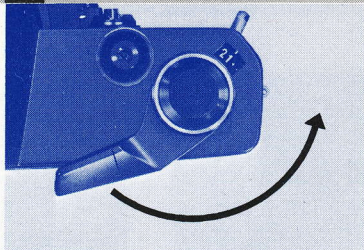

Shoot blank exposures by advancing the film and depressing the Shutter Release Button until the Exposure Counter indicates "1" (one).

5



Set the Film Speed by turning the Film Speed Ring while depressing the Lock Button until the ASA/DIN number of the film being used appears in the window.

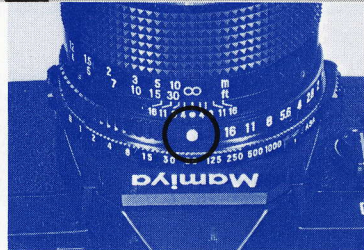

Set the Aperture Ring to "AE" by rotating until it locks into place with the orange "AE" button aligned with the Central Index Mark.

9



Compose the image and gently depress the Shutter Release Button.

10

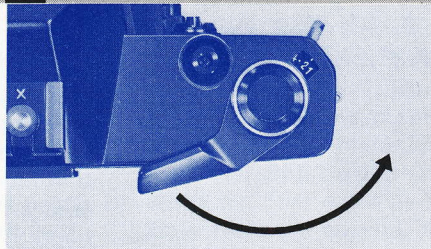

Advance the film to the next frame.

11

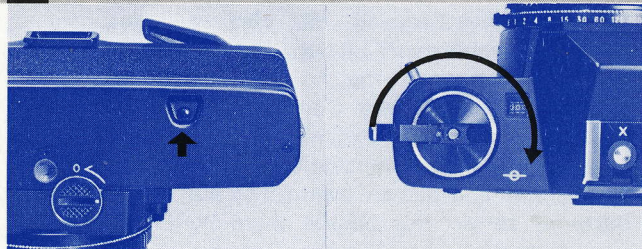

Rewind the film after the entire roll has been exposed.

Inserting Batteries

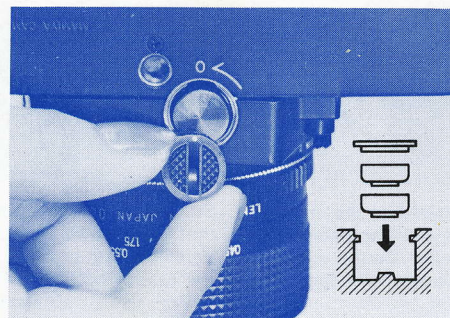
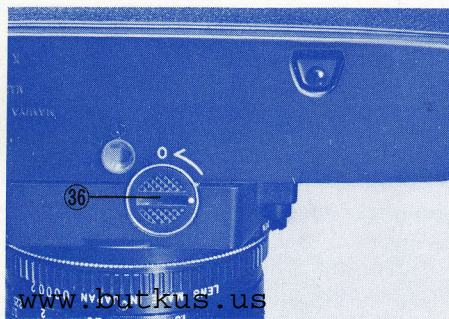

Remove the Battery Compartment Cover (36) by rotating it a quarter-turn counterclockwise with a fingertip or coin. Insert two 1.5V silver-oxide batteries (Eveready S-76, Mallory MS-76 or equivalent) into the Battery Compartment with the + (positive) side facing the Battery Compartment Cover (it has a plus sign indicated as a reminder on its underside). Perspiration, grease and dirt are harmful to the batteries so do not handle them by your fingertips when inserting into the battery compartment. Batteries should be wiped with a soft, dry cloth or

tissue before insertion. After inserting batteries, replace the Battery Compartment Cover, aligning its white dot with the "O" (open) symbol indicated on the camera, and lock cover into place by rotating it a quarter-turn (90°) clockwise.

Precautions

1. Do not use 1.3V mercury batteries which are similar in size and shape. Even if a battery fits into the chamber, if it is not a silver-oxide battery, proper functioning of the camera cannot be guaranteed.
2. When the camera is not used for a long period of time, remove the batteries and store them in a cool, dry place. Be careful so that the plus and minus sides are not accidentally touching and shorted.
3. When replacing batteries, properly dispose of the used batteries immediately as they are potentially dangerous. Silver-oxide batteries are explosive and should never be thrown into a fire.
4. To assure consistent performance and the utmost accuracy, your Mamiya camera is equipped with an electronic shutter. However, when the batteries are exhausted, or there are no batteries in the Battery Compartment, the focal-plane shutter will function normally only at B (bulb), and when the Shutter Speed Ring is set to any shutter speed other than B, a speed of approximately 1/1000 sec. will result. Of course, the metering system will not operate at this time.

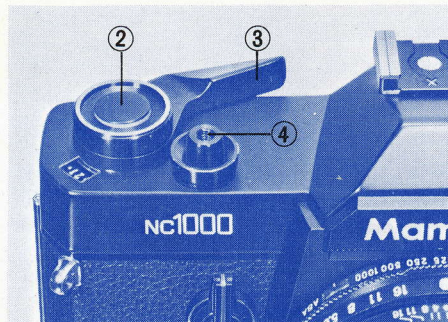
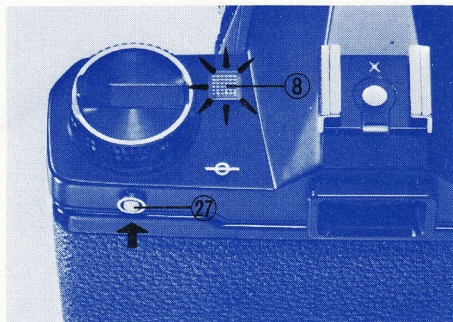

Battery Check

After inserting the batteries, check their voltage by pushing the Battery Check Button (27). If the Battery Check Lamp (8) illuminates, it indicates the batteries are in good condition. Battery condition should also be checked when the camera has not been used for a long period of time. When the Battery Check Lamp fails to light, remove the batteries and wipe with a soft, dry cloth to assure good contact. Failure of the Battery Check Lamp to light after wiping the bat-

teries indicates they must be replaced with fresh batteries.

Exposure Meter Switch

When the Film Advance Lever (3) is slightly pulled away from the camera (about 1/2 in. or 1.5cm) to its click-stop, the exposure meter is activated. To turn off the meter, merely depress the Meter OFF Button (2).

When the Film Advance Lever is pulled away from the camera, the Meter OFF Button will "pop" up, exposing an orange rim which serves as a reminder that the exposure meter is turned on.

★ On the NC 1000, depressing the Meter OFF Button simultaneously turns off the exposure meter and locks the Shutter Release Button (4) preventing the possibility of an accidental exposure.

Loading Film

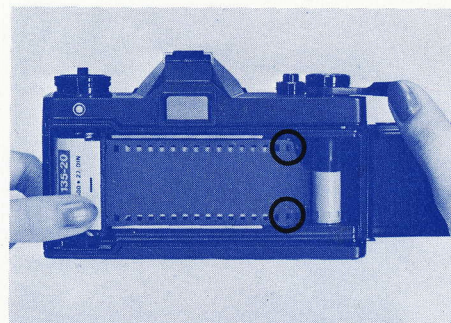
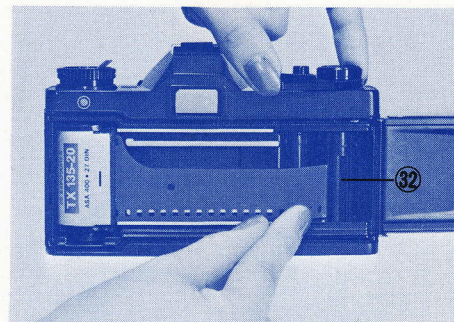
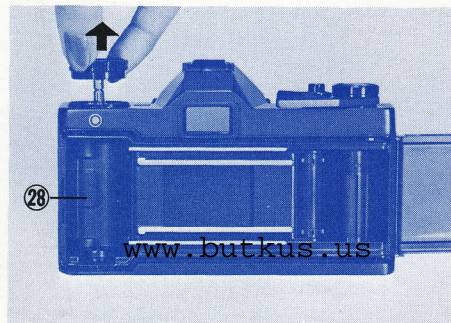

Avoid direct sunlight when loading and unloading film. Pull up on the Film Rewind Knob (7) to open the Back Cover (33), and drop a 35mm film cartridge into the film chamber (28), locking the cartridge into place by pushing down on the Film Rewind Knob. If the Film Rewind Knob does not return flush with the camera top, rotate it while gently pushing downward until it recesses flush.

Insert the film leader into one of the slots in the Film Take-up Spool (32). The arrow appearing on the Film Take-up Spool indicates the direction in which it revolves.

Wind the film until both the upper and lower sprockets (31) are engaged in the film perforations. If the Film Advance Lever stops advancing, free it by depressing the Shutter Release Button (4). Before securely closing the Back Cover, take up all the slack in the film by gently rotating the Film Rewind Knob clockwise.

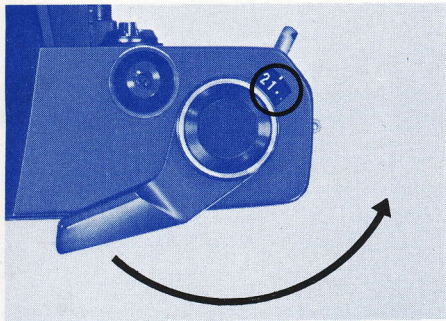

Move the Film Advance Lever as far as it will go and then depress the Shutter Release Button. Repeat the above procedure until the Exposure Counter indicates 1 (one). The camera is now loaded and ready to use.

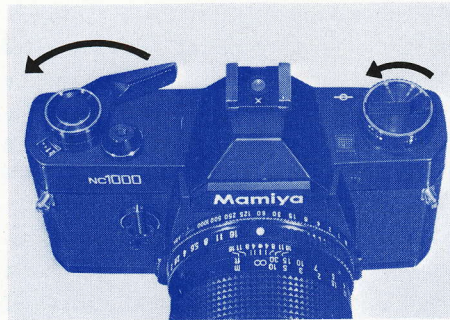

Each time the film is advanced and the shutter cocked, the Exposure Counter advances one number, informing the user of the number of frames the film has been advanced. When the Back Cover is opened, the Exposure Counter automatically returns to "S" (start).

As the film is advanced, the Film Rewind Knob should revolve counter-clockwise. If it does not, it indicates there is slack in the film, or the film is not being advanced at all.

Turn the Film Rewind Knob clockwise to take-up the slack, then depress the Shutter Release Button and wind the film again. If the Film Rewind Knob still does not turn, open the back and check the film loading.

Setting the Film Speed



Before taking pictures, be sure to adjust the camera to the film speed of the film being used. To do so, turn the Shutter Speed Ring (16) while depressing the Film Speed Ring Lock Button (18) until the correct ASA or DIN number (as indicated on the film information sheet) appears in the appropriate window (14). When setting the film speed, hold the knurled portion of the Film Speed Ring (17) with one hand and depress the Film Speed Ring Lock Button with the other hand.

The correct values of the dots appearing between the ASA and DIN numbers are indicated by the smaller numbers in the table below.

ASA	25	32	40	50	64	80	100	125	160	200	250	320	400	500	650	800	1000	1600	3200			
DIN	15	16	17	18	19	20	21	22	23	24	25	26	27	28	29	30	31	32	33	34	35	36

Setting the AE Button

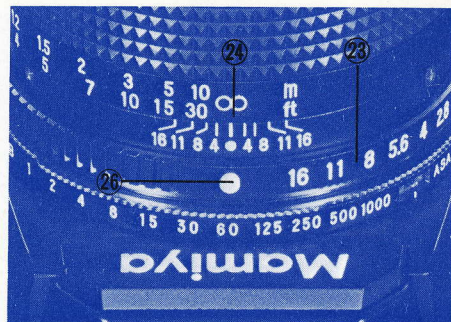

When using the automatic exposure (AE) system of your camera, be sure to set the Aperture Ring (23) of the lens to the AE position. To do so, rotate the Aperture Ring until the orange AE Button (26) is aligned with the similarly colored Central Index Mark (24). When set to the AE position, the Aperture Ring will lock into place.

Caution:

Automatic exposure is not possible when the Aperture Ring is NOT set to the AE position.

Do not set the Aperture Ring to the AE position while depressing the Depth-of-Field Preview Button. If you turn the Aperture Ring forcefully, the AE mechanism of the lens will be damaged though the Aperture Ring will be stopped just prior to reaching the AE position. (When operating the camera to see the depth-of-field in the viewfinder, be especially careful to avoid the operation described above.)

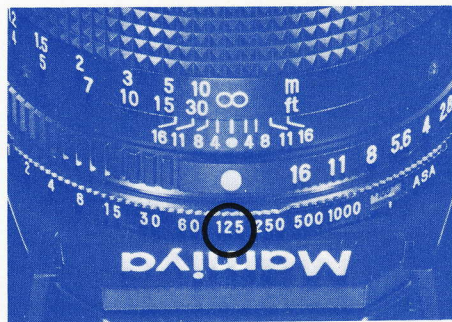

The shutter speed plays a very important role in determining the sharpness of your pictures. Therefore, as a general rule, use as fast a shutter speed as the prevailing lighting conditions allow. For sharp pictures, do not use shutter speeds longer than 1/30 sec. (1/15 to 1 sec., or longer) unless the camera is mounted on a sturdy tripod and the shutter is tripped with a cable release.

To select a shutter speed, rotate the Shutter Speed Ring (16) until the desired shutter speed is aligned with the Central Index Mark.

The numerals on the Shutter Speed Ring indicate fractions of a second; thus, "500" represents 1/500 second. For an exposure time of longer than 1 second, the Shutter Speed Ring is set to "B" (bulb). In this position, the shutter will remain open for as long as the Shutter Release Button is depressed.

For general purpose photography, you may find it useful to set the Shutter Speed Ring to the speed indicated in the following table.

Lighting Condition	Shutter Speed
Outdoors, Sunny	1/250 or 1/125 sec.
Cloudy or in the shade	1/125 or 1/60 sec.
Twilight or interiors	1/30 sec.

Focusing



1. While looking through the viewfinder, adjust the Focusing Ring until the most important part of the subject appears sharp.

2. Extremely accurate focusing is simplified by the split-image rangefinder spot located in the center of the focusing screen. Its wedge is set at a 45° angle, making it possible to use either horizontal or vertical lines of the subject for precise focusing. The split-image rangefinder spot is surrounded by a microprism collar which fractures the image whenever it goes slightly out-of-focus; consequently, it is an invaluable aid for pinpoint focusing accuracy.

3. The outer ground glass area (which surrounds the microprism collar) can also be used for focusing.

Since the camera is an SLR, the photographer always sees in the viewfinder exactly what will appear on the film, regardless of the lens or accessory being used.

Moreover, simply depressing the Depth-of-Field Preview Button after setting the Aperture Ring to the desired F-stop will allow one to preview the Depth-of-Field and appearance of out-of-focus images.



Viewfinder Information

- Rangefinder Spot
- Microprism Collar
- Matte Area
- Stop-Down Metering Index Mark
- Indicator Needle
- Aperture Scale

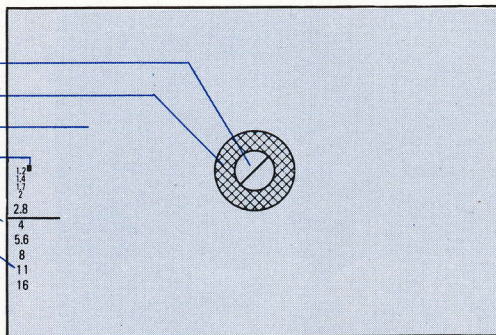

Pull the Film Advance Lever slightly away from the camera to its click-stop position and look through the viewfinder to check that the Exposure Meter Indicator Needle is located within the correct exposure area before releasing the shutter.

● Correct Exposure Area

The correct exposure area is anywhere between the upper edge of the numeral corresponding with the maximum aperture and the lower edge of the numeral

of the minimum aperture of the lens being used.

For example, when using an $f/1.4$ lens and the Indicator Needle points anywhere between the upper edge of 1.4 and lower edge of 16 on the aperture scale in the viewfinder, correct exposure will be obtained.

When using an $f/1.7$, $f/2$, or $f/2.8$ lens, the upper edge of the respective numeral on the aperture scale in the viewfinder is the upper limit of the correct exposure. When using an $f/3.5$ lens, the

lower edge of 2.8 is the upper limit of the correct exposure.

If the Indicator Needle moves beyond the upper limit, underexposure will result, so adjust the Shutter Speed Ring to a slower shutter speed until the Indicator Needle drops into the correct exposure area.

If the Indicator Needle lies below the lower limit, this indicates overexposure, and the Shutter Speed Ring should be adjusted to a faster shutter speed until the Indicator Needle enters into the correct exposure area.

Aperture Scale:

The Aperture Scale is found on the left-hand side of the focusing screen area. The Exposure Meter Indicator Needle moves up and down in this area, indicating the aperture automatically selected by the camera when the Aperture Ring of the lens is set to the AE position.

Holding the Camera Correctly

Stop-Down Metering Index:

This index is the small rectangular area found beside 1.2 on the Aperture Scale. For manual stop-down metering, the Indicator Needle is aligned with this index. Details appear later in this text.



Support the camera in the palm of the left hand with the thumb and forefinger gripping the Focusing Ring. The palm of the right hand should fit against the right side of the camera body with the forefinger resting near the Shutter Release Button and the thumb on the camera back.

Look through the viewfinder with the camera resting against the forehead to help steady it and the left elbow held in against the body.

As a general rule, the camera should not be handheld at shutter speeds slower than 1/30 second. This becomes particularly important when using lenses of longer than normal focal length, where it may be necessary to use even faster speeds to eliminate camera movement. At speeds slower than 1/30 sec., a tripod is a must for optimum sharpness.

Caution:

★ During automatic exposure (AE) operation, be careful not to inadvertently apply pressure to the Meter OFF Button while releasing the shutter, otherwise incorrect exposure may result.

★ When attaching the camera to a tripod that has a long attachment screw, adjust the screw to less than 3/16 inch (4.5mm) to prevent damage to the interior of the camera body.

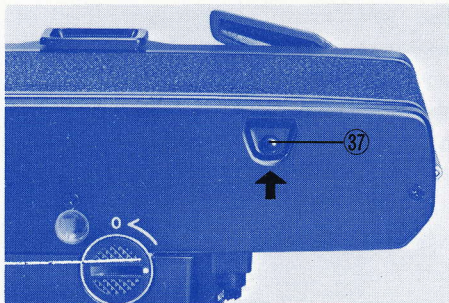

After exposing a roll of film, it must be rewound into its cartridge, for if the Back Cover of the camera were to be opened without first rewinding, anywhere from a few frames to the entire roll may be ruined.

To rewind the film, push in on the Rewind Button (37) and gently rotate the Rewind Knob (7) with its fold-away Rapid Rewind Crank in the direction of the arrow (clockwise). To avoid damaging the film, do not rewind the film too rapidly nor apply excessive force. After the tip of the

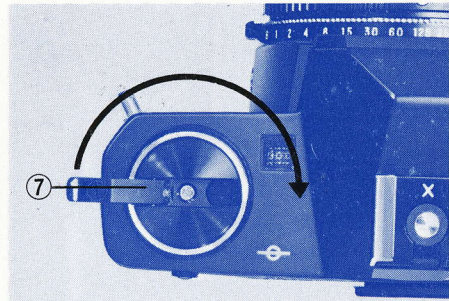

film leader separates from the Take-up Spool, there will be less tension upon the Rewind Knob and this indicates it is safe to open the Back Cover.

To prevent the possibility of fogging the first few frames, do not unload the film in direct, bright light nor rewind the film completely into its cartridge, but leave part of the film leader protruding to prevent light from leaking in between the felt lips of the cartridge.

Using the Self-Timer

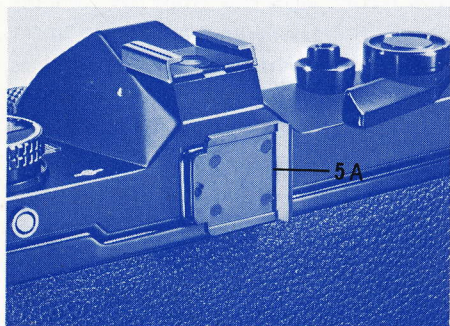
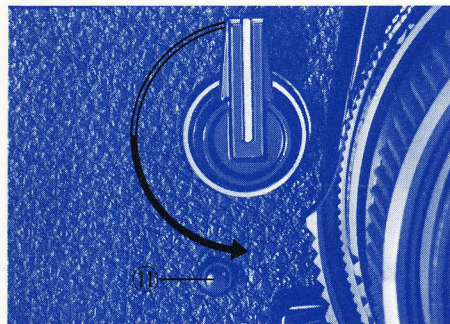

The Self-Timer provides a method of taking delayed action pictures, allowing a photographer to get into his own photographs!

When ready to take a picture, rotate the Self-Timer Lever (10) counter-clockwise and push the Self-Timer Activating Button (11) to start the Self-Timer.

Rotating the Self-Timer Lever as far as it will go (180°) will result in a shutter release delay of approximately 9 seconds. The time delay is adjustable by rotating the Self-Timer Lever in a 90 to 180° arc. However, when rotated to an angle of less than 90° , the Self-Timer will not start.

The Self-Timer Lever may be set either before or after the film is advanced. Starting the self-timer before the film is advanced, however, will not result in releasing the shutter.

Even after setting the self-timer, it can be by-passed as often as desired

by releasing the shutter with the Shutter Release Button.

Caution:

When using the self-timer in the automatic exposure (AE) mode, be sure to attach the Hot Shoe Safety Cover (5A) (which also doubles as a viewfinder cover) to the Viewfinder Eyepiece (29) to prevent extraneous light from entering the eyepiece, possibly causing underexposure.

When using the self-timer, be sure the Film Advance Lever is at its click-stop position, protruding slightly from the camera. If the lever is flush with the camera top, the meter is turned off.

If the self-timer is started with the Film Advance Lever flush with the camera top, the shutter will not release because pushing the Meter OFF Button not only turns off the meter, but also locks the shutter release mechanism. In the event that the self-timer is

accidentally started with the Film Advance Lever flush with the camera top, pull the lever out to its click-stop position and then reset the self-timer; there will be no need to push the Self-Timer Activating Button again because the self-timer will start as soon as pressure is released from the Self-Timer Lever.

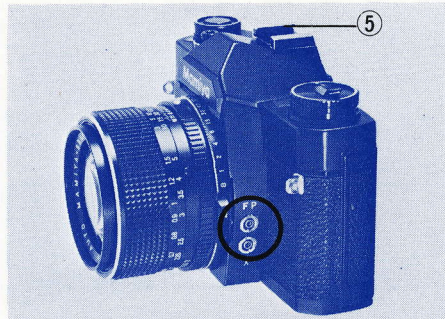

Your camera is provided with two flash Sync Terminals: FP for synchronization with FP class flash bulbs, and X for synchronization with electronic flash units.

Compact electronic flash units designed for cordless operation may be attached to the Hot-Shoe (5) after its Safety Cover is removed. For a large flash unit used with a bracket, or for a compact electronic flash unit without provision for cordless operation, attach the flash synchronization cord to the

appropriate Sync Terminal.

Caution:

When using flash units with synchronization cords, an electrical charge is present in the "Hot Shoe". Therefore, keep the Safety Cover (5A) in place to prevent the possibility of a light electrical shock while the cord is connected. The Hot-Shoe Safety Cover, as explained in the previous section, USING THE SELF-TIMER, also doubles as a viewfinder eyepiece cover.

Flash Synchronization Chart

The shaded areas of the Flash Synchronization Chart indicate the usable shutter speeds with the various types of flash illumination. For example, when using electronic flash, the Shutter Speed Ring should be set to 1/60 sec. or slower (1/60 to 1 sec., B).

FLASH TERMINAL	SHUTTER SPEEDS										
	1/1000	1/500	1/250	1/125	1/60	1/30	1/15	1/8	1/4	1/2	1
FP	FP Class										
							M Class				
X						Electronic Flash					
							FP Class · M Class				
							MF Class				

● Exposure for Flash Photography

In flash photography, exposure is determined by the guide number of the flashbulb or electronic flash unit.

The guide number represents a relationship between the power of the flash and the speed of the film. Flashbulb guide numbers can be found on their package. Guide numbers for electronic flash units are found in the manufacturers specifications.

Once you've found the correct shutter speed for your type of flash, (see Flash Synchronization Chart), you can

compute the correct lens opening by this formula.

$$\begin{aligned} & \text{GUIDE NUMBER} \div \text{CAMERA-} \\ & \text{TO-SUBJECT DISTANCE} \\ & = \text{APERTURE} \end{aligned}$$

If the flash you are using has a guide number of 56, for example, and if, after focusing, you determine from the lens barrel Distance Scale that the subject is 7 feet away, divide 56 by 7. The answer is 8, therefore the correct aperture is f/8 ($56/7=8\{f/8\}$).

Not only is flash the most effective

light source for indoor photography and for shooting in dimly-lit places, but it's also an effective tool for back-lighting outdoor portraits and filling in shadows outdoors.

Remember that when flash is used as a supplemental light source, exposure must be based on the light from the main light source (such as the sun).

Remember, also when shooting with electronic flash, the Shutter Speed Ring must be set to 1/60 sec. or slower (1/60 – 1 sec., B).

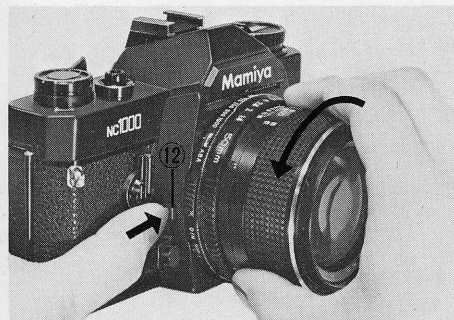

To remove the lens from your camera, push in on the Lens Release Button (12), securely grip the lens by the lens barrel, give it a short (approximately 45°) twist counterclockwise, and after the lens stops, merely lift it straight out of the bayonet mount.

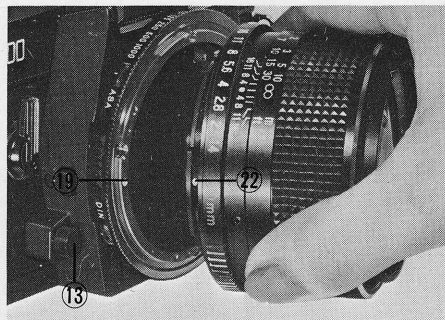

Attach the lens to the camera as follows: while matching the red Alignment Dots (19 & 22), seat the lens in the bayonet mount, giving it a short (approx. 45°) twist clockwise until it comes to a stop with a click, locking into place.

Caution:

- ★ Do not apply pressure to the Depth-of-Field Preview Button (13) while interchanging lenses, as it may cause damage to the diaphragm automation pin on the lens.
- ★ When the lens is removed, protect the mirror chamber of the camera from dirt, and never touch the mirror. If dirt particles must be removed from the mirror chamber, use a blower or soft brush.
- ★ Protect your camera body and lens by using lens and body caps.

Advanced Technique



In order to meet almost every photographic need, the Mamiya NC 1000 includes a variety of features. Mastery of these features will not only lead to better pictures, but will open up the doors to new photographic possibilities as well.

When the camera is focused on an object, an area in front of and behind the object will also be in acceptably sharp focus.

The distance between the nearest and farthest points in sharp focus is called DEPTH-OF-FIELD.

Each time the aperture is changed, the depth-of-field changes also. As the lens is stopped down towards f/16, depth-of-field increases, and as the lens is opened up towards f/1.4 or f/1.7, it decreases.

The depth-of-field will appear in the viewfinder as it will appear in the finished picture. By changing the focus while the lens diaphragm is stopped down, you can select the area of sharpness in your photograph.

Knowing how to use depth-of-field allows the photographer to use the principle of "selective focus" to give softer focus to unwanted foreground and background subjects. This could

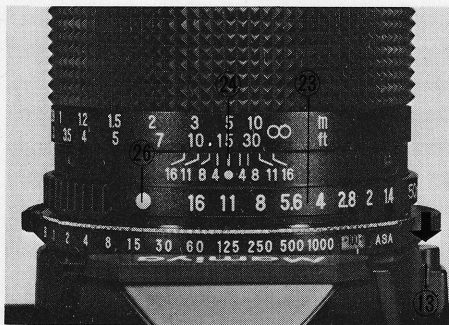

mean the difference between a snapshot and a much more successful photograph.

To preview the depth-of-field push in on the AE Button (26) and rotate the Aperture Ring (23) until the same F-number indicated by the Exposure Meter Indicator Needle is aligned with the Central Index Mark (24).

Next, push the Depth-of-Field Preview Button (13) as far as possible and the diaphragm of the lens will stop down to the previously selected aperture,

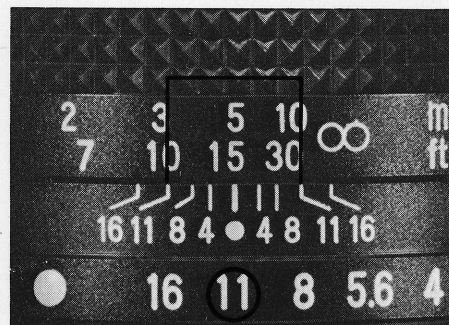

making it possible to preview the depth-of-field. Releasing your finger from the Depth-of-Field Preview Button will return the diaphragm to its maximum aperture. After this is done, you can take a picture. However, it is better to return the Aperture Ring to the AE position immediately after previewing the depth-of-field to minimize the possibility of future error.

If the focusing screen is not sufficiently bright, because of a dark subject or small aperture, to clearly distinguish

the depth-of-field, you can determine the approximate depth-of-field by referring to the Depth-of-Field Scale (24) on the lens barrel.

For example, if the standard (50mm) lens is focused at 15 feet, one of the marks representing $f/11$ appears at the 10 foot mark and the other at the 30 foot mark. This means that in a photograph focused at 15 feet with the diaphragm set at $f/11$, everything between 10 and 30 feet will be in acceptably sharp focus.

The automatic exposure system can be disengaged at any time by pushing the AE Button to unlock the Aperture Ring and rotating it to the desired aperture. Even when in the manual mode, the Exposure Meter Indicator Needle continues to indicate correct exposure so that it may be used as a reference point to assist the photographer who deliberately wishes to over or underexpose for special effects. For example, when the Indicator Needle indicates $f/8$, the photographer can overexpose two stops by manually setting the Aperture Ring to $f/4$; similarly, he can underexpose two stops by setting the Aperture Ring to $f/16$ instead of $f/8$.

Your Mamiya camera automatically computes correct exposure in most photographic situations. However, in unusual circumstances such as when the background area is large and much brighter or darker than the subject, it is best to make an exposure adjustment to lighten or darken the principal area of interest.

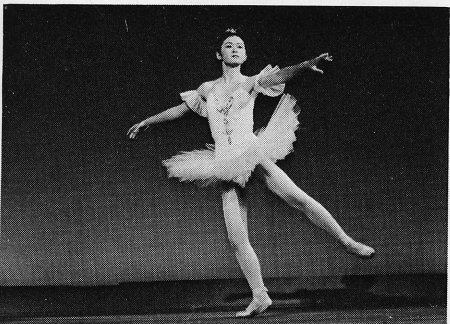

● AE Correction for a Bright Background

When the background is exceptionally bright, as when the subject is strongly back-lit, underexposure of the subject will normally occur and this will render the subject excessively dark. To prevent this from happening, tilt the camera so that the bright background or bright light source is not included in the viewfinder and then press the Shutter Release Button slightly (about 1mm) to lock the exposure in place. After the Indicator Needle locks, re-

compose the image in the viewfinder while maintaining pressure on the Shutter Release Button. Then, apply additional pressure to the Shutter Release Button to trip the shutter and take the picture.

When you desire to have a brightly back-lit subject appear as a silhouette, do not make the exposure correction suggested above, but simply compose and shoot.

● AE Correction for a Dark Background

When the background is very dark in relation to the subject, as when photographing a stage performer standing in a spotlight against a dark curtain, overexposure will normally occur, washing out (overexposing) the subject. To correct for this type of situation, move very close to the subject, excluding the dark background from the viewfinder, and lock the exposure into place by

slightly depressing the shutter release button. While maintaining pressure on the shutter release button to "hold" the correct exposure, back away from the subject, recompose, and shoot.

If it is not possible to approach the subject, take an exposure measurement from a similarly lighted subject (such as one's own hand), lock the exposure, recompose, and shoot.

Using Infrared Film

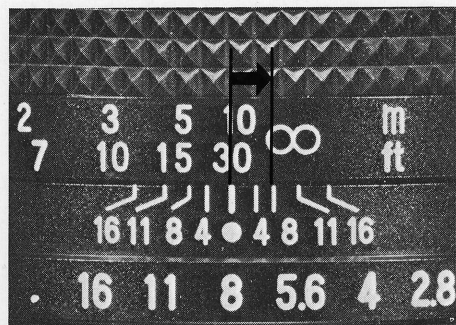

When using black and white infrared film it is necessary to make a focusing adjustment in order to achieve accurate focus. This focusing adjustment is particularly important when:

- a) using non-wide-angle lenses
- b) taking close-ups
- c) shooting at wide apertures

● Focusing Adjustment Procedure

1. The red dot or line on the right side of the Central Index Mark is the Infrared Index Mark.

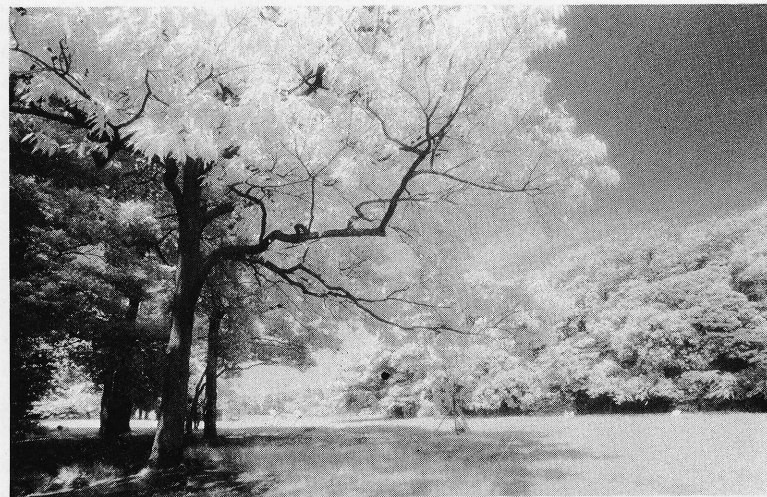

2. After focusing in the usual manner, check the distance on the distance scale that is aligned with the Central Index Mark of the lens, and then make a focusing adjustment by turning the focusing ring slightly in the direction indicated by the arrow in the accompanying photograph so that the dis-

tance previously indicated on the Central Index Mark is now aligned with the Infrared Index Mark.

★ For information regarding the proper filter and exposure, refer to the data sheet packed with the film.

★ A focusing adjustment is not required with color infrared film.

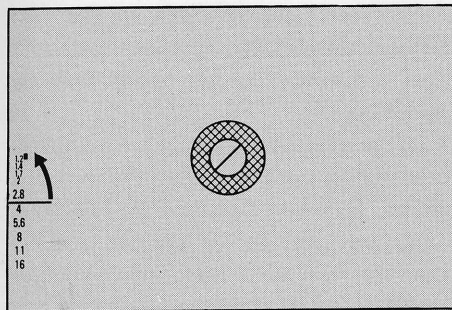

When an Auto Mamiya-Sekor CS lens is attached to the camera, stop-down metering is not possible. However, stop-down metering is used on the following occasions:

1. When an accessory, such as Auto Bellows is placed between the camera body and lens.
2. When lenses for the TL, DTL, SX series or any other universal (42mm) thread lenses are mounted on the Mamiya NC 1000 using the P (Praktica) Mount Adapter.
3. When preset lenses are used.

In the stop-down metering method, there is no relationship between the F-number indicated by the Exposure Meter Indicator Needle and the aperture required to achieve correct exposure. When stop-down metering is necessary, proceed as follows:

1. Focus on the subject and, while pushing the Depth-of-Field Preview Button (13) as far as possible rotate the Aperture Ring until the Indicator Needle comes to rest at the Stop-Down Metering Index Mark (found beside 1.2 on the Aperture Scale). Correct exposure is now set and the picture is ready to be taken. (When using preset lenses, there is no need to manipulate the Depth-of-Field Preview Button.)
2. If the Indicator Needle cannot be aligned with the Stop-Down Metering Index Mark by rotating the Aperture Ring, change to another shutter speed. If the Indicator Needle lies below the Stop-Down Metering Index, change to

a faster shutter speed. Conversely, when the Indicator Needle lies above the index, change to a slower shutter speed. It is not necessary for the Indicator Needle to be perfectly centered in the Stop-Down Metering Index Mark, for when the Indicator Needle enters any area of the index, it indicates that the camera has been adjusted within the range of correct exposure.^o

3. After adjusting for correct exposure, the usual practice is to remove one's finger from the Depth-of-Field Preview Button before releasing the shutter so that composition and focus can be rechecked at the maximum aperture. However, it is perfectly acceptable to release the shutter while the Depth-of-Field Preview Button is still held.

Multiple-Exposures

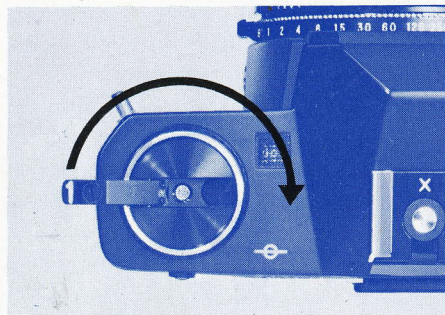

The NC 1000 camera is protected from accidental double exposures under normal picture taking situations, however, you can make multiple (double) exposures for special effects as follows.

1. Take your first picture in the usual manner.
2. Rotate the Film Rewind Knob clockwise until it stops to take up slack in the film.
3. Wind the Film Advance Lever while holding the Film Rewind Knob so that the knob will not be moved, simultaneously keeping the Rewind Button depressed.
4. Depress the Shutter Release Button for second exposure. Repeat the above steps if you wish, for as many times as you wish. The Exposure Counter advances as many numbers as the Film Advance Lever is wound.

★ If you take up slack in the film before releasing the first exposure, the film movement in the camera will be minimized.

★ The next frame might be slightly overlapped with the multiple exposed frame, so when finishing the multiple-exposures, put on the lens cap or cover the lens with your hand, trip the Shutter Release Button, and advance one blank shot of film.

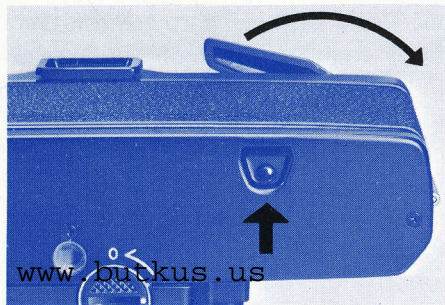

Mamiya-Sekor CS Lenses

www.butkus.us

Lens	Construction		Angle of View	Minimum Aperture	Diaphragm	Minimum Focusing Distance	Filter Size	Lens Hood	Weight
	Groups	Elements							
28mm f/2.8	7	8	75°	16	AE	1 ft. or 0.3m	49mm	Screw-in	6 oz. (170g)
35mm f/2.8	6	6	63°	16	AE	1.5 ft. or 0.4m	49mm	Screw-in	5.4 oz. (150g)
50mm f/1.4	6	7	47°	16	AE	1.5 ft. or 0.45m	49mm	Screw-in	7.3 oz. (205g)
50mm f/1.7	5	6	47°	16	AE	1.5 ft. or 0.45m	49mm	Screw-in	5.2 oz. (145g)
Macro 50mm f/3.5	4	5	47°	16	AE	0.75 ft. or 0.22m	49mm	Screw-in	7.4 oz. (210g)
135mm f/2.8	4	5	18°	16	AE	5 ft. or 1.5m	52mm	Built-in	11.1 oz. (315g)
200mm f/3.5	4	4	12°	16	AE	7.5 ft. or 2.3m	58mm	Built-in	17.3 oz. (490g)

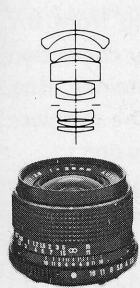

28mmf/2.8

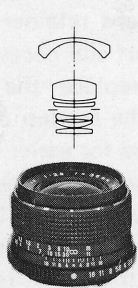

35mmf/2.8

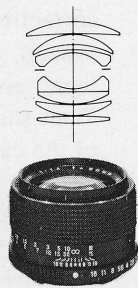

50mmf/1.4

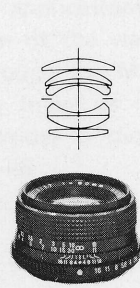

50mmf/1.7

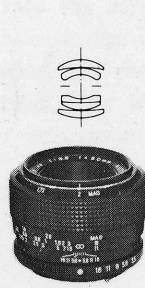

Macro
50mmf/3.5



135mmf/2.8



200mmf/3.5

Accessories

● Filters

A series of five high quality filters have been designed to maintain the high performance of Mamiya-Sekor CS lenses. They come in 49, 52, and 58mm sizes, and in the following types: SY48 (Y2), SO56 (O2), SL39 (UV), YG, SL-1B (Skylight).

● Lens Hoods

Lens hoods play an important role in minimizing stray light, a source of internal reflections which can lead to the formation of ghost images and the reduction of contrast. In order to enjoy your Mamiya-Sekor CS lenses to the fullest, lens hoods should always be used with the lenses for which they were specifically designed.

Screw-in lens hoods are available for the 28mm and 35/50mm lenses. Telephoto lenses have built-in retractable lens hoods.

● Diopter Correction Lenses

Many near and farsighted persons have difficulty looking through a camera viewfinder while wearing glasses, but they can not focus accurately without them. This common problem can be corrected by using a diopter correction lens that mounts easily over the viewfinder eyepiece with the separately available Adapter and Rubber Eyecup. Diopter correction lenses are available in strengths of +3, +2, +1, -1, -2, and -3.

To attach a correction lens merely unscrew (counterclockwise) the diopter correction lens retainer ring from the eyecup, insert the necessary correction lens, and replace the retainer ring. Then slide the eyecup on the eyepiece of the camera for easier focusing.

Before actually purchasing a Diopter Correction Lens at your Mamiya Dealer, be sure to attach it to the camera and try viewing through it to assure correct matching with your eyesight.

● Rubber Eye-cup with Adapter

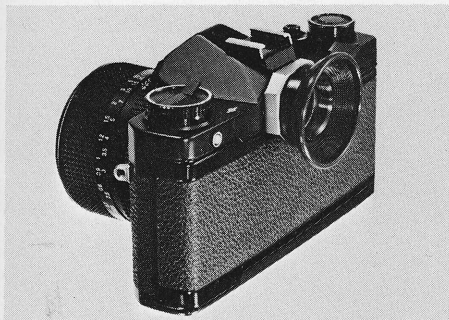

The Rubber Eyecup also helps to prevent unwanted light from entering the viewfinder from the back and sides while viewing.

● Magnifier

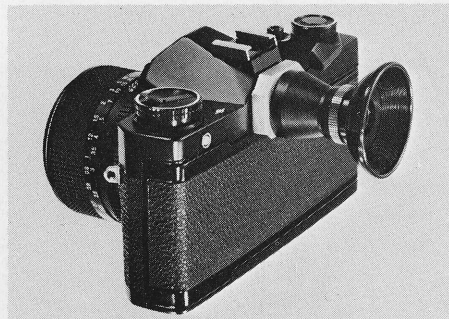

The Magnifier is a useful aid for critical focusing as required in copy work, close-up photography, and similar applications. Only the center portion of the viewfinder image is visible through the Magnifier, and the size of the image is doubled. The Magnifier provides a diopter adjustment of +5 to -5.

● Angle Finder



The Angle Finder is useful for low angles and copy work. The Angle Finder has click stops every 90° , but freely rotates a full 360° and has built-in diopter corrections of -4 to +4. Furthermore, the image seen through the Angle Finder is bright, unreversed, and laterally correct for ease of operation.

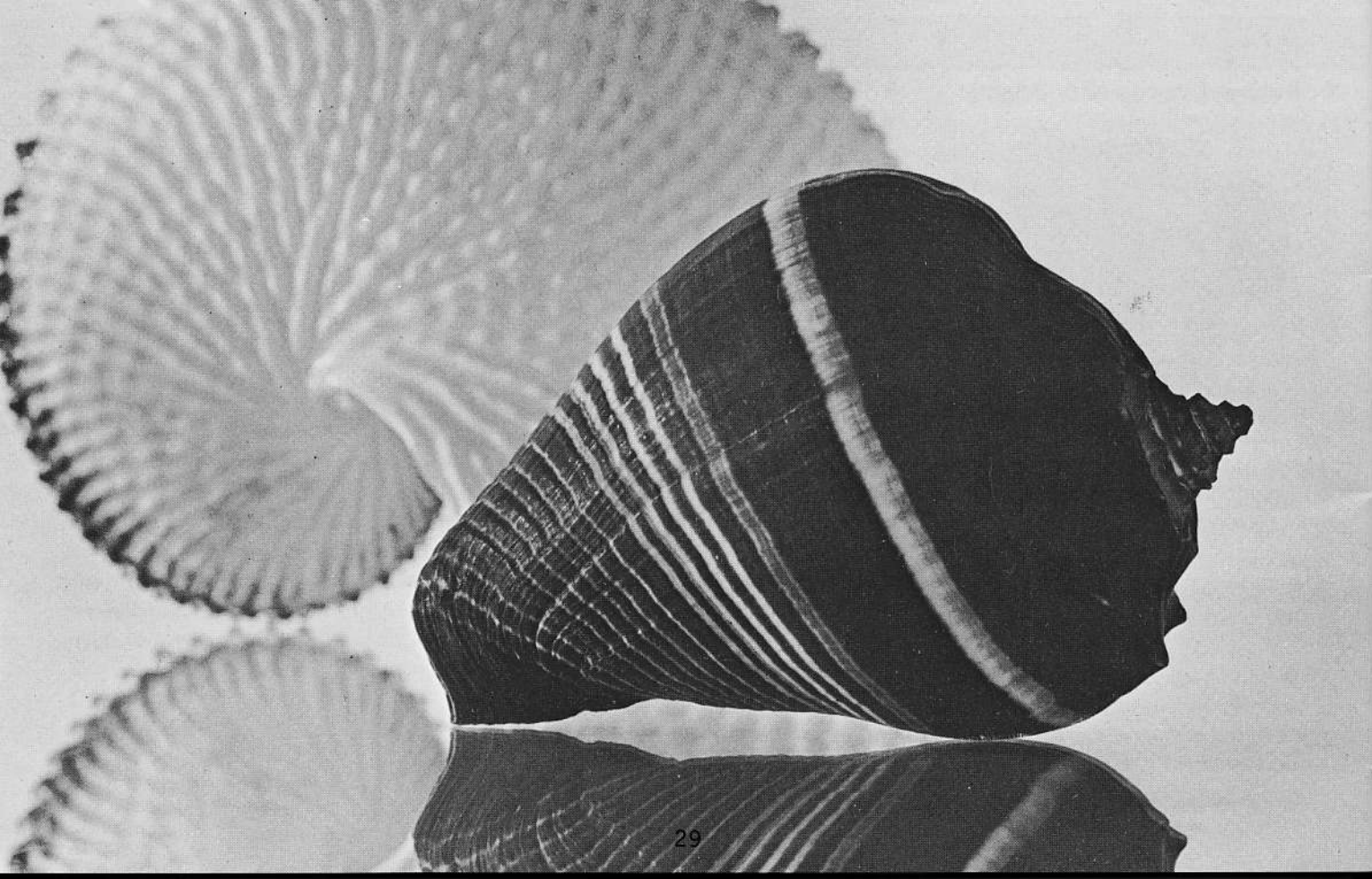

● Auto Extension Tube Set

A set of three tubes, of different lengths, which are mounted between the camera body and lens. They may be used singly or in combination for close-up photography at various magnifications. Diaphragm automation of the lens is retained, allowing focusing and composing of the subject at the maximum aperture.



● Auto Bellows

A versatile bellows unit to introduce the photographer to the exciting world of photomacrography. This deluxe unit has rack and pinion control for the bellows extension and allows precise adjustments in magnification. Moreover, after the unit is placed close enough to the subject for the image

to be in focus, fine focusing can then be carried out by the Focusing Rail of the unit which moves the camera body. Additional features include a double cable release for diaphragm automation and provision for mounting the lens reversed for large magnifications.



Accessories

● Slide Copier

Used with the bellows unit, the slide copying attachment is mounted in front of the lens to allow the photographer to copy slides and film strips. It has a slide stage that moves in any direction to make it easy to crop mounted slides for better composition and a removable film tray to facilitate copying long rolls of 35mm film.

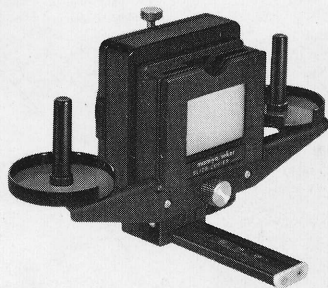

● Bellows Stand

The bellows stand is actually a stage for photographing small objects. The platform rotates to allow for the best positioning of the subject with small clips to hold it in place. The surface of the stage itself has a reflectance of approximately 18%, ideal for exposure measurements. A clear glass stage is provided to allow for backlighting and incident light measurement.

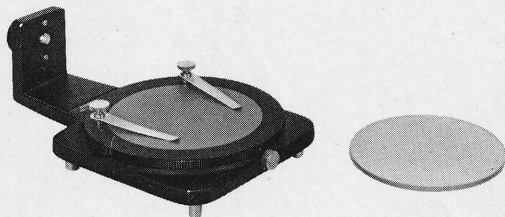

● P (Praktica) Mount Adapter

This adapter permits using lenses for the TL, DTL, SX, series and other universal (42mm) screw mount lenses on the Mamiya NC 1000. Correct exposure is easily determined by aligning the Exposure Meter Indicator Needle with the Stop-Down Metering Index Mark. Moreover, diaphragm automation, where applicable, is fully retained with this adapter.

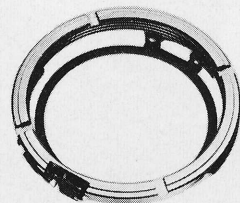

Care of the Camera

● Cleaning:

Use a blower or camel hair brush to clean the entire film compartment before loading film into the camera. Never use your breath to blow dust or dirt from the compartment as the moisture can corrode the precision working parts.

To clean the lens surface, wipe **VERY GENTLY** in a circular motion with a quality lens tissue. In severe cases you can use a very small amount of lens cleaning solution, again wiping in a circular motion. **NEVER RUB THE LENS TO REMOVE DIRT OR GRIT!** If the dirt will not come loose with a brush or blower, take the camera to a factory approved service technician. Never touch the lens with your fingers or any material other than a lens tissue. Dirt on the reflex mirror will not affect your photograph.

● Storage:

Store your camera in its case with the lens set to infinity and protected by its lens cap. Be sure to turn off the meter when storing the camera (this will also give the added protection of locking the Shutter Release Button).

If the camera will not be used for an extended period of time, remove the batteries.

Never store the camera in areas where the temperature exceeds 100 degrees F or goes below freezing (32 degrees F).

Protect the camera against moisture by using a desiccant. Never expose the camera to direct sunlight for extended periods of time.

Avoid areas where prolonged exposure to salt water or briny air is possible.

Specifications

Camera Type:

Ultra compact, shutter speed priority AE (Automatic Exposure) 35mm SLR with manual override.

Film and Negative Size:

35mm film, 24mm x 36mm.

Standard Lenses:

Auto Mamiya-Sekor CS Multi-Coated 50mm f/1.4 (7 elements in 6 groups, AE, automatic diaphragm, 47° angle of view, 49mm filter size).

Auto Mamiya-Sekor CS Multi-Coated 50mm f/1.7 (6 elements in 5 groups, AE, automatic diaphragm, 47° angle of view, 49mm filter size).

Lens Mount:

Mamiya Bayonet (three-flange, 49mm diameter) Mount.

Shutter:

Electronically controlled rubberized silk focal plane shutter with range of 1/1000 – 1 sec., B (bulb).

Self-Timer:

Variable time delay of approximately 4–9 sec.; has its own Activating Button and can be by-passed.

Sync Terminals:

FP, X, and a Hot-Shoe for cordless flash operation.

Exposure Meter:

Ultra sensitive center-weighted CdS meter with exposure measurement range of EV 2–18 (100 ASA, f/1.4 lens).

Coupling:

With Mamiya-Sekor CS lenses in AE mode: ASA, shutter speed, and lens maximum aperture.

With Mamiya-Sekor CS lenses in manual mode: ASA, shutter speed, and lens maximum aperture. Working aperture is directly read from viewfinder Aperture Scale and manually set.

With preset lenses: ASA and shutter speed. Exposure measurement is by zero-method stop-down metering.

Film Speed Range:

ASA, 25–3200; DIN 15–36.

Viewfinder:

Large, brilliant pentaprism SLR viewing. Exposure Meter Indicator Needle, Aperture Scale, and Stop-Down Metering Index Mark visible in viewfinder. Magnification of 0.94X with 50mm lens at infinity. Three-way focusing: Central rangefinder wedge at 45° angle surrounded by a microprism collar which is located in a matte field, with finely-grooved Fresnel lens for even illumination.

Mirror:

Quick-return mirror, coated for increased reflectance.

Film Advance Lever:

Single-action type with short 130° throw and stand-off angle of 15°, double-exposure prevention, and with Meter OFF Button incorporated into lever (Meter OFF Button also doubles as Shutter Release Button Lock).

Exposure Counter:

Additive type with automatic reset.

Power Source:

Two 1.5V silver oxide batteries (Eveready S-76, Ray-O-Vac RS-76, Mallory MS-76 or equivalent) supply the power for the electronic shutter and exposure meter.

Dimensions and Weight:

Body only	5 11/32" x 3 17/64" x 1 31/32" (136 x 83 x 50mm) 18 oz. (510g)
With f/1.4 lens	5 11/32" x 3 17/64" x 3 1/2" (136 x 83 x 89mm) 25.3 oz. (715g)
With f/1.7 lens	5 11/32" x 3 17/64" x 3 3/16" (136 x 83 x 81mm) 23.2 oz. (655g)

NOTE: Because we are always striving to improve our products, specifications are subject to change without notice.