



MINOLTA

www.butkus.us

OWNER'S MANUAL

CLE

E

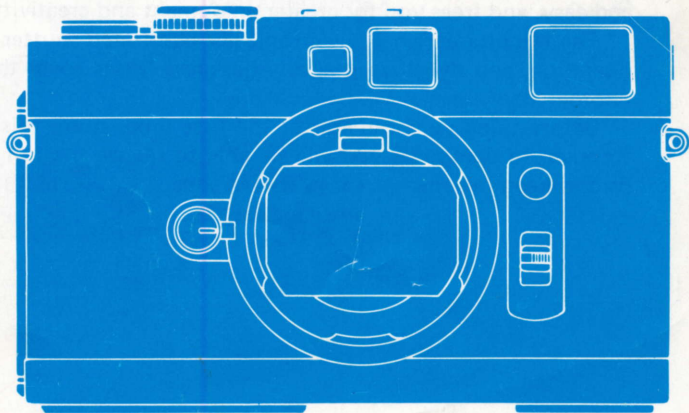



This manual is for reference and historical purposes, all rights reserved.

This page is copyright© by M. Butkus, NJ.

This page may not be sold or distributed without the expressed permission of the producer

I have no connection with any camera company

On-line camera manual library

This is the full text and images from the manual. This may take 3 full minutes for the PDF file to download.

If you find this manual useful, how about a donation of \$3 to: M. Butkus, 29 Lake Ave., High Bridge, NJ 08829-1701 and send your e-mail address so I can thank you. Most other places would charge you \$7.50 for a electronic copy or \$18.00 for a hard to read Xerox copy.

This will allow me to continue to buy new manuals and pay their shipping costs.

It'll make you feel better, won't it?

**If you use Pay Pal or wish to use your credit card,
click on the secure site on my main page.**

PayPal Name Lynn@butkus.org

Your new, lightweight and compact Minolta CLE is the world's first rangefinder camera with interchangeable lenses and TTL automatic and manual-exposure systems.

The patented Minolta TTL off-the-film metering system forms the heart of the CLE's aperture-priority automation and provides exceptional exposure accuracy.

Features such as the exclusive Touch Switch/shutter release that activates the meter and the finder's LED shutter-speed display makes taking photographs with the CLE fast and easy, and frees you for greater enjoyment and creativity.

The Minolta designed, electronically controlled shutter assures you of smooth, quiet operation, and the three specially designed lenses cover the range most widely used by photographers.

Before using your camera for the first time, study this manual carefully all the way through. In doing this you will be able to realize the full potential of your camera. Be sure to keep this manual for later reference.

CONTENTS

NAMES OF PARTS	2	OPERATION	24
PREPARATION AND BASICS	4	AUTOMATIC	24
BATTERIES	4	Automatic-exposure adjustment	26
Installing batteries	4	MANUAL	27
Battery check	6	"B" Setting	28
Cold-weather operation	6	DEPTH OF FIELD	29
ATTACHING AND REMOVING		Depth-of-field scale	29
LENSES	7	INFRARED INDEX	30
To attach	7	FLASH OPERATION	31
To remove	8	Automatic operation with the Minolta	
MAIN POWER SWITCH	9	Auto Electroflash CLE	31
TOUCH SWITCH/SHUTTER		With Minolta X-series Auto	
RELEASE	10	Electroflashes	32
SETTING FILM SPEED	10	With other flash units	34
LOADING AND REWINDING FILM ..	12	ACCESSORIES	36
VIEWFINDER	17	SPECIFICATIONS	41
FOCUSING	18	CARE AND STORAGE	44
HOLDING THE CAMERA	20		
SELF-TIMER	22		

www.butkus.us

NAMES OF PARTS



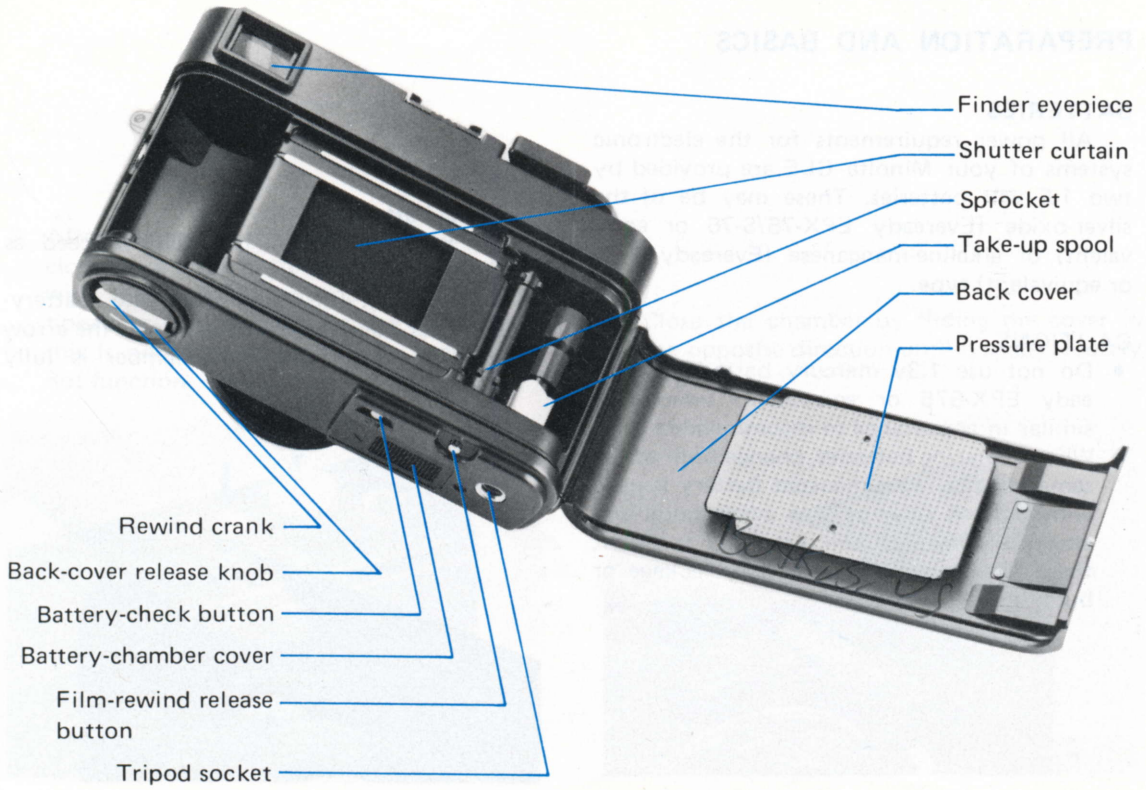

Finder eyepiece

Shutter curtain

Sprocket

Take-up spool

Back cover

Pressure plate

Rewind crank

Back-cover release knob

Battery-check button

Battery-chamber cover

Film-rewind release
button

Tripod socket

PREPARATION AND BASICS

BATTERIES

All power requirements for the electronic systems of your Minolta CLE are provided by two 1.5 volt batteries. These may be of the silver-oxide (Eveready EPX-76/S-76 or equivalent) or alkaline-manganese (Eveready A-76 or equivalent) type.

CAUTIONS

- Do not use 1.3v mercury batteries (Eveready EPX-675 or equivalent) which are similar in appearance to recommended cells.
- When replacing batteries, change both at the same time. If an exhausted battery is used with a fresh one, or if a silver-oxide and alkaline-manganese cell are used together, there is a possibility of battery leakage or bursting.

Installing batteries

To properly install batteries, proceed as follows:

1. Press down on and slide the battery-chamber cover in the direction of the arrow until it stops and the chamber is fully uncovered.

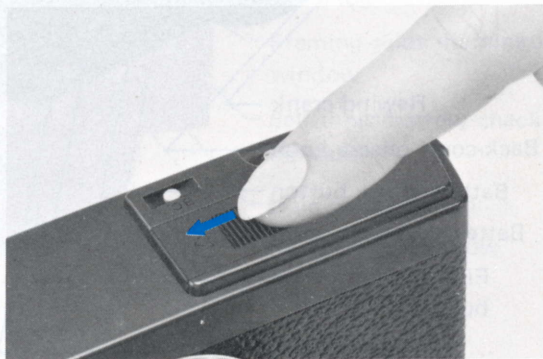

2. After wiping the terminals with a clean dry cloth, insert the batteries into the chamber with their negative and positive ends positioned as indicated inside the chamber. If this is not done correctly, the camera will not function.

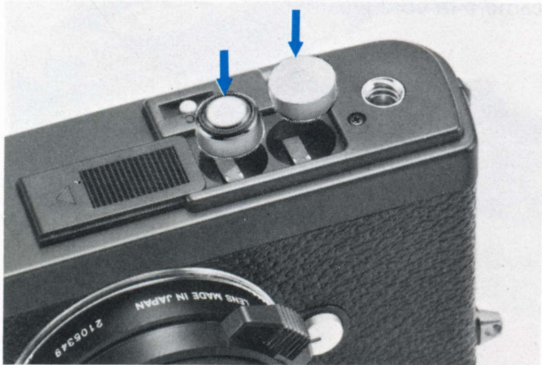

3. Close the chamber by sliding the cover in the opposite direction until it snaps securely into place.

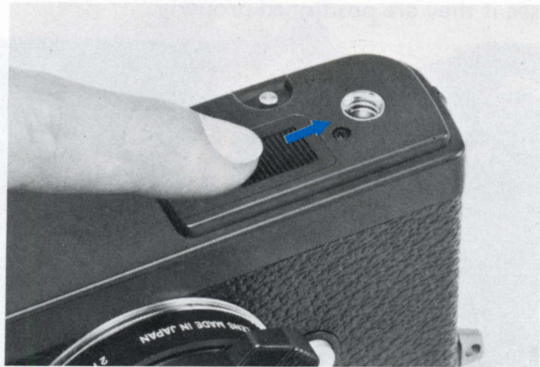

Battery check

To check battery strength, press the gray battery-check button on the bottom of the camera. If the red LED self-timer/battery-check indicator lights, the batteries are serviceable. If the indicator does not light, replace the batteries, or if they have just been installed, check to see if they are positioned properly.

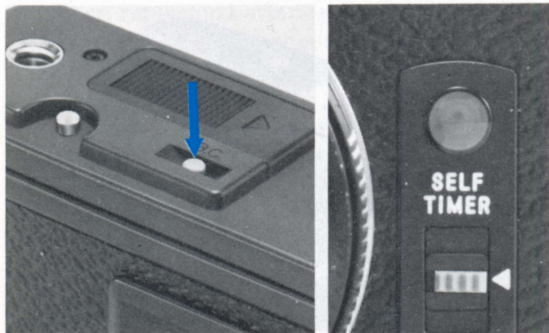

Cold-weather operation

Batteries by nature tend to lose power as temperatures drop. While the alkaline-manganese batteries will meet all requirements under normal conditions, for heavy sustained cold-weather operation (approx. -10°C) it is recommended that silver-oxide type batteries (Eveready EPX-76/S-76 or equivalent) be used.

Regardless of which battery type used, remember to always use fresh batteries and keep a spare set with you when using your camera in cold-weather.

ATTACHING AND REMOVING LENSES

To Attach

1. Remove the body cap from the camera by depressing and holding down the lens-release button. Turn the cap to the left, and lift it out of the camera body.



2. Remove the rear lens cap by turning it counterclockwise.

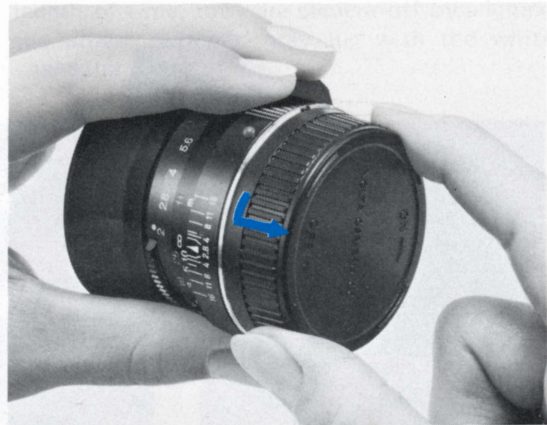

3. Align the raised red dot on the lens with the red index line on the release button, insert the lens into the body and turn it to the right. An audible click will be heard when the lens is securely mounted.



To Remove

1. Grip the rear of the lens and press and hold down the lens-release button. Turn the lens as far as it will go to the left, and lift it out from the body.



MAIN POWER SWITCH

Located on the front of the camera is a three-position slide switch that turns power from the batteries on or off, and sets the self-timer (See p.22).

To move the switch, place your finger on the raised gray lug and slide it towards the lens. The switch can now be slid up or down to the desired position.

The switch locks into place at the "ON" and off (indicated by a white triangular index) positions, but does not lock when set at "SELF-TIMER."

To prevent battery drain or accidental exposures when the camera is not being used for any length of time, turn the camera off by aligning the power switches' gray lug with the white triangular index.

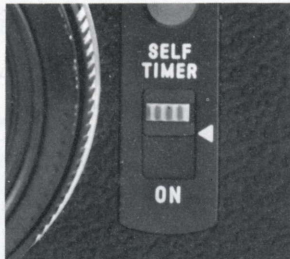

TOUCH SWITCH/SHUTTER RELEASE

Finger contact with the touch switch/shutter release activates the camera's electronic shutter and when the shutter-speed/function selector is set at "A," powers the electronic exposure control and LED circuits. If proper contact with the switch is not possible (i.e., while wearing gloves or when fingers are dry), slight pressure on the switch will also activate the camera's electronic circuits.

Depressing the touch switch/shutter release all the way down fires the camera.

NOTE

Wipe off any dust or dirt that may accumulate on the touch switch with a clean, dry cloth. This will insure proper contact and operation.

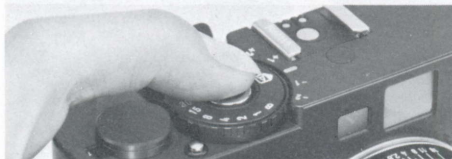

SETTING FILM SPEED

Each film has an ASA or DIN exposure-index number to indicate its sensitivity to light. For correct exposure, the camera's meter must be set for the exposure index of the film in use.

To do this, lift up on the knurled ring of the shutter-speed/function selector and turn it until the proper ASA indication appears in the center

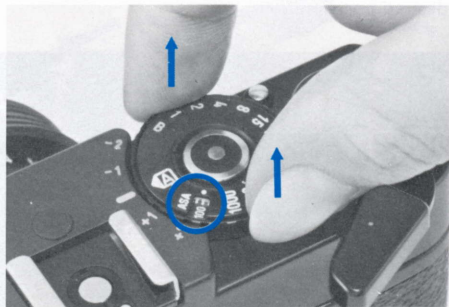

of the film-speed window and locks in that position when the ring is released. Marks between the numbered graduations indicate ASA numbers as shown in the following ASA/DIN table.

ASA		DIN			
25		15	•	250	25
•	32	16	•	320	26
•	40	17	400		27
50		18	•	500	28
•	64	19	•	640	29
•	80	20	800		30
100		21	•	1000	31
•	125	22	•	1250	32
•	160	23	1600		33
200		24			

Located on the back cover of the camera is a convenient ASA/DIN conversion table and memo holder. The memo holder can be used to hold a film-box end as a reminder of the film in use.



LOADING AND REWINDING FILM

To open the camera back and load a film cartridge, proceed as follows:

1. Unfold the rewind crank and pull the back-cover release knob all the way out.
2. Turn the release knob in the direction of the arrow until the back cover springs open.

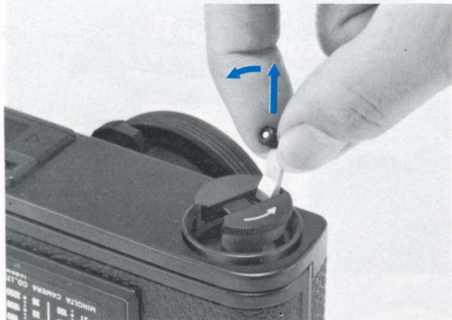

3. Leaving the knob pulled out, position a film cartridge in the chamber with the projecting-spool end toward the bottom of the camera. Then push the back-cover release knob all the way in, rotating it if necessary.

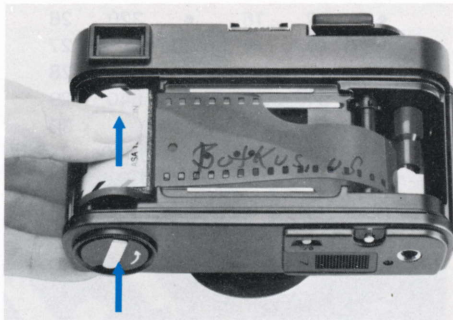

4. Insert the end of the film leader as shown into one of the slots in the take-up spool so that the tooth is engaged with a sprocket hole near the end of the leader. Make sure the end of the leader does not project from another slot between tabs on the spool.

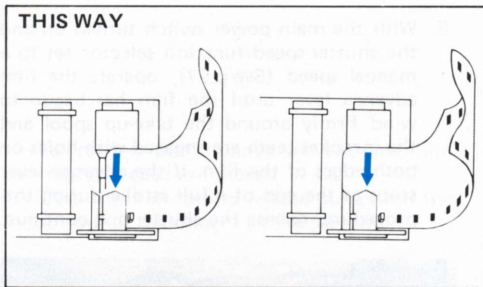
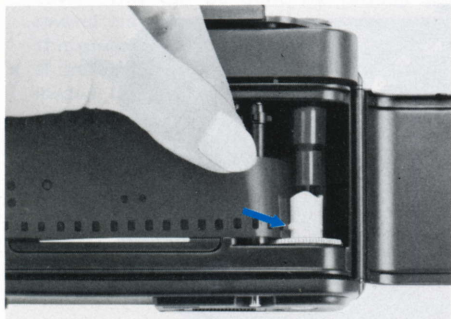

NOT THIS WAY

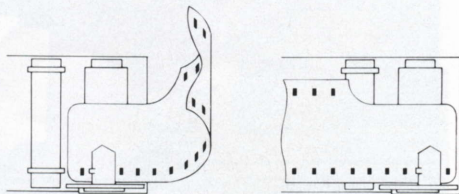

5. With the main power switch turned on and the shutter-speed/function selector set to a manual speed (See p.27), operate the film advance lever until the film has begun to wind firmly around the take-up spool and the sprocket teeth are engaged with holes on both edges of the film. If the advance lever stops at the end of a full stroke during this procedure, release the shutter and continue.

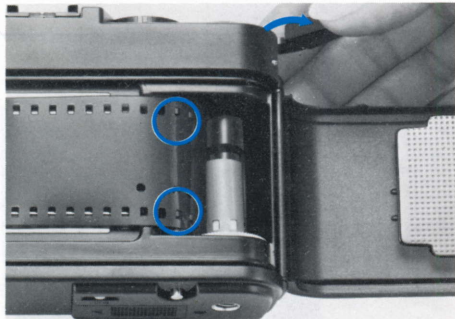

6. Close the camera back and push in on it until it clicks shut.
7. A red "S" should now appear in the center of the frame-counter window. Advance film and release the shutter until "1" appears in the center of the window.



NOTES

- To check if film is loaded correctly, watch the rewind crank when you advance the film. If it turns when the film is advanced, the camera is properly loaded. If it does not turn, repeat steps 1 through 6.
- When the camera has not been used for a period of time, check to see if there is film in the camera before you open the back cover. This can be done by turning the rewind crank in the direction of the arrow. If it turns freely the camera is not loaded.
- If the camera is fired without film being loaded, the shutter speed will be slower than indicated by the LED's in the viewfinder. This is a result of the direct-metering system reading from the film-pressure plate which is of low-reflectance, and does not indicate a camera malfunction.

To rewind and remove an exposed film cartridge, proceed as follows:

1. Press the film-rewind release button on the bottom of the camera all the way in.

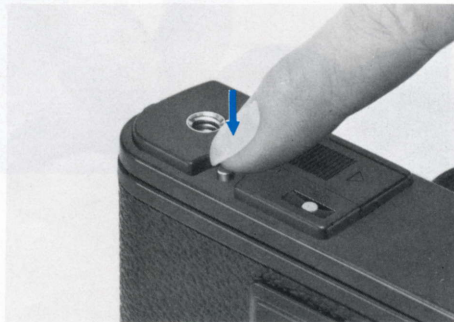

2. Unfold the rewind crank and turn it in the direction of the arrow. When tension on the crank disappears and it turns freely, the film is fully rewound.
3. Pull the back-cover release knob all the way out, and turn it in the direction of the arrow until the back cover springs open. Remove the film cartridge.



www.butkus.us

NOTES

- The film counter automatically resets itself when the back cover is opened.
- Film should be loaded and unloaded in subdued light — at least shaded from direct sunlight by the body.
- When the advance lever stops and resists further movement at the end of a film, never attempt to force it farther.



VIEWFINDER

When you look through the viewfinder of your Minolta CLE, you will observe the following items:

- A. LED shutter-speed indicators and scale
- B. LED over-/under-range indicators
- C. Rangefinder field
- D. Framing guides for 90mm focal-length lens
- E. Framing guides for 40mm focal-length lens
- F. Framing guides for 28mm focal-length lens

For further operational details, see the following sections on focusing and camera operation.

NOTES

- The 28mm framing guides are always visible in the viewfinder, regardless of lens attached. They are also visible when no lens is fixed to the camera. The 40mm and 90mm framing guides are visible only when their respective focal-length lenses are attached.
- Viewfinder framing guides are coupled with the lens-focusing movement for automatic parallax compensation.

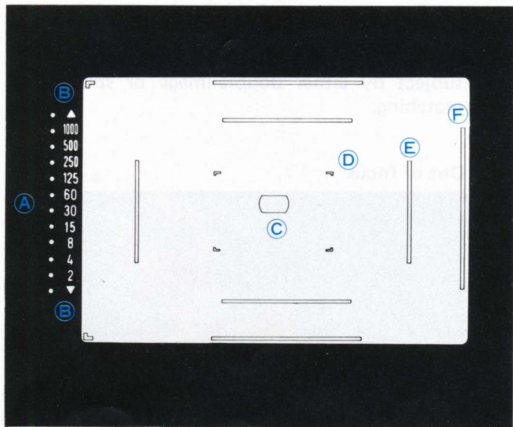

The rangefinder field appears in the center of the viewfinder as a bright and sharply outlined area. You can use it to focus on a subject by either double-image or split-image matching.

Out of focus



For double-image (coincidence) focusing, for instance on a highlight in the eye of a person, observe the subject through the finder and turn the lens focusing ring until the two images fuse into one.

In focus



For split-image focusing, sight an edge or other clear outline and turn the lens focusing ring until the broken outline appears continuous in the rangefinder field. This is the more accurate and therefore the preferable method of focusing.

Out of focus

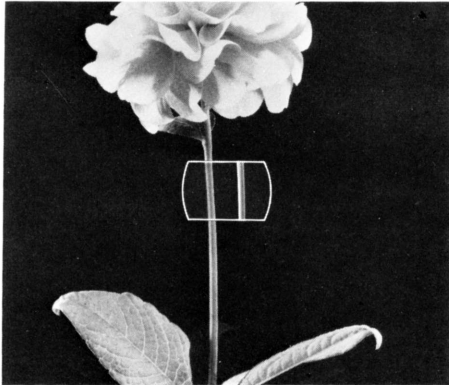

In focus

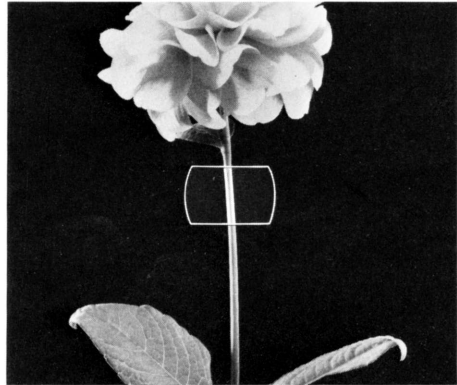

HOLDING THE CAMERA

For a steady three-point support, grip the camera with the right hand so that the index finger is on the touch switch/shutter-release and the thumb against the film-advance lever. Use the left hand to either support the lens from below for rapid focusing and aperture adjustment, or to grip the left side of the camera. In addition, press the camera to your forehead for extra support.



For vertical shots, simply turn the camera 90°. Keep the same grip on the camera as for horizontal shots.

When the shutter is released, it should be done with a slow, steady pressure, never a quick jab. Holding your breath at the time of release, with the camera or hands holding it firmly steadied against your face or body, will help prevent blurred pictures.



When conditions call for exposure times too long for hand-holding the camera, it should be mounted on a tripod using the built-in socket on the bottom of the camera, and the shutter tripped with a Minolta electronic Remote Cord (p.38) or standard cable release. Either can be screwed into the threaded remote-release socket on the side of the camera body.

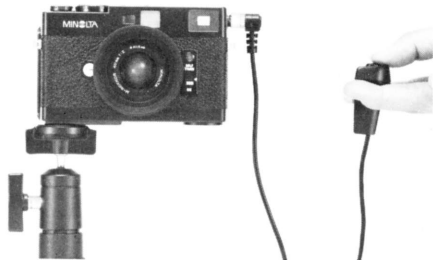

Your Minolta CLE has a built-in electronic self-timer that will delay shutter release for approx. 10 seconds. Operation of the self-timer is as follows:

1. Advance film, adjust focus and make necessary camera settings.
2. Move the main power switch to the "SELF-TIMER" position (p.9).



3. Depress the shutter release to start the timer cycle. The red LED self-timer/battery-check indicator will begin to blink, indicating the timer cycle has started. Approx. 2.5 seconds before the exposure is made, the LED indicator will blink faster to alert you.

NOTES

- The self-timer will not operate when the shutter-speed/function selector is set at "B" (bulb).
- When finished using the timer, be sure to move the main power switch from the "SELF-TIMER" setting.



OPERATION

AUTOMATIC

In its automatic mode, your Minolta CLE is a aperture-priority automatic exposure-control camera that steplessly controls shutter speed in accordance with set lens aperture and metered light conditions.

To use your camera's automatic exposure control, proceed as follows:

1. After setting film speed (p.10) and turning the main power switch on (p.9), turn the

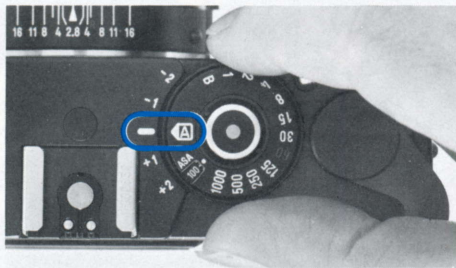

shutter-speed/function selector to align the "A" with the white index line. At this point the selector will lock into position to prevent accidental movement.

2. Set desired lens opening by turning the aperture ring on the lens barrel.
3. Look through the viewfinder and focus on and compose your subject or scene.



4. Place your finger on the touch switch/shutter release to activate the camera's metering system and confirm the automatically selected shutter speed by the LED indicator lights.

If one LED indicator lights, the automatically set shutter speed will be exactly or approx. as indicated. If two LED's are lit, set shutter speed will be between the speeds indicated.

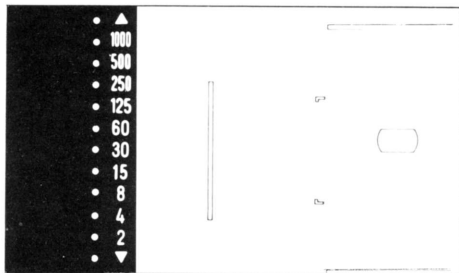

If either of the over-/under-range indicator lights, open up or close down the lens accordingly until an LED indicator within the coupled metering range lights up. The coupled metering range varies according to the speed of the film in use. The following table illustrates the coupled range of the CLE's meter for various film speeds.

ASA Film Speed	Coupled Metering Range
From 25 to 100 ASA	1/2 to 1/1000 sec.
200 ASA	1/4 to 1/1000 sec.
400 ASA	1/8 to 1/1000 sec.
800 ASA	1/15 to 1/1000 sec.
1600 ASA	1/30 to 1/1000 sec.

5. If indicated shutter speed is within range, press the shutter release all the way down to make the exposure.

Automatic-exposure adjustment

To deliberately give more or less exposure while in automatic mode, set the shutter-speed/function selector as follows:

Depress the Auto-setting release and move the shutter-speed/function selector so that the "A" is on the side having plus (+) numbers to produce more exposure, or on the side having minus (-) numbers to produce less exposure. The numbers indicate the amount of adjustment in stops or EV steps (i.e., "+1" indicates one more stop or double the normal automatic exposure, and "+2" means two stops or four times more exposure: "-1" is one stop less or one half the exposure, and "-2" produces two stops' less or one quarter the normal exposure). The shutter-speed/function selector will lock at

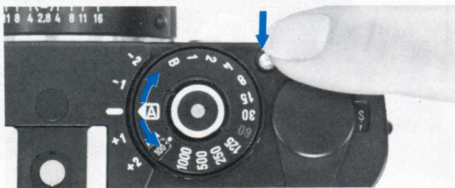

the normal automatic setting and there are click-stops at each half-stop setting.

The "A" may be set at intermediate positions between +2 and -2.

Always return the shutter-speed/function selector to "A" (normal automatic operation) after using exposure-adjustment settings.

NOTES

- The CLE's automatic exposure system will not operate when the "A" on the shutter-speed/function selector is moved outside the range of exposure adjustment.
- When using R60 filter, set the "A" on the shutter-speed/function selector at +1/2.

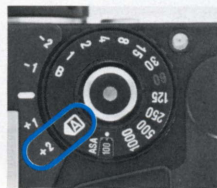
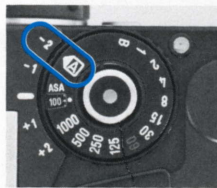

"B" Setting

Turning the shutter-speed/function selector to align "B" with the white index line sets the camera for making "bulb" exposures. At this setting the shutter will open when the shutter release is pressed and remain open until it is released. This allows taking exposures longer than 1 sec. for night scenes or special effects.

With fresh silver-oxide batteries, a continuous exposure up to four hours long can be made if ambient temperature is 20 to 30°C. Continuous exposure time will be shorter in cold weather or with alkaline-manganese batteries.

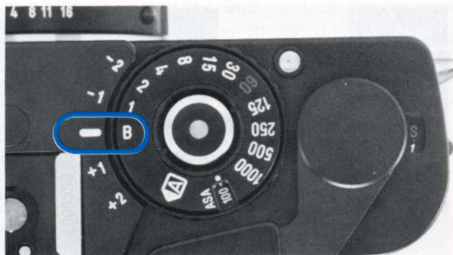

Use of a tripod and remote release are recommended when making bulb exposures. If a tripod is used, do not use excessive force when attaching the camera to the tripod.

If a standard cable release is used instead of the electronic Minolta Remote Cord, do not let any metal part of the cable release touch any metal part of the camera, as this will close the shutter and end the exposure.

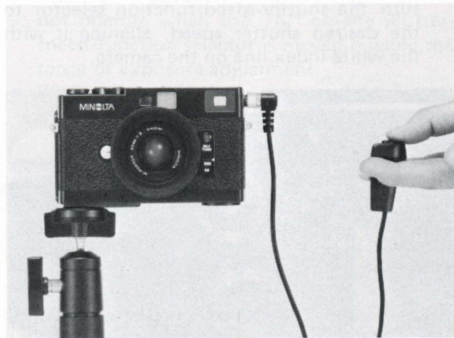

DEPTH OF FIELD

The distance behind and in front of the focused distance within which the image appears acceptably sharp is called the depth of field.

It extends a greater distance behind the focused distance than in front and is determined by three factors: the aperture size, the

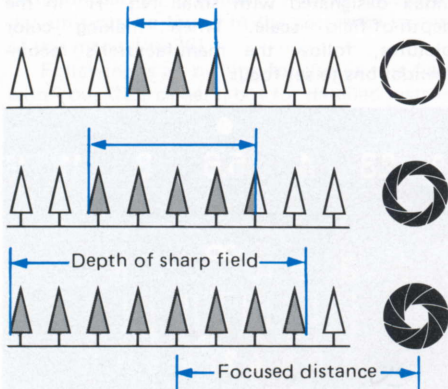

distance at which the lens is focused, and the focal length of the lens in use. Depth of field increases as the lens is stopped down (e.g., $f/2$ to $f/16$) and becomes greater the farther from the camera the lens is focused. It decreases as the lens is opened up (e.g. $f/16$ to $f/2$) and the closer to the camera the lens is focused. Depth of field is greater for short focal-length lenses than for telephoto's at the same focused distance and aperture. It is at its least for any given lens in normal mounting when the lens is at maximum aperture and at minimum focusing distance.

Depth-of-field scale

The near and far limits of acceptable sharpness can be determined from the depth-of-field scale on the lens barrel. With the lens focused at a given point, the image will be in satisfactory focus from the nearer value to the farther value on the distance scale indicated by the depth-of-field scale marks for the aperture to be used.

For example, if a 40mm lens is focused at 3m (about 10 ft.) and the aperture is f/8, the appropriate graduations to left and right of the index on the depth-of-field scale indicate acceptable sharpness from about 2m to 5.8m (approx. 7 to 19 ft.).

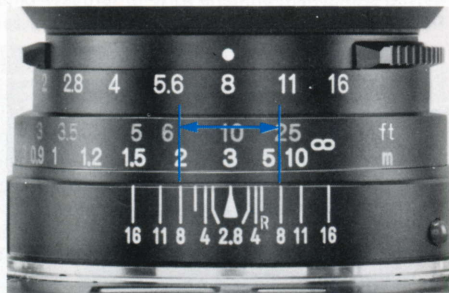

INFRARED INDEX

For proper focus when taking pictures with infrared radiation, first focus on your subject with visible light as described above, then attach a red filter (R60 or O56) and turn the focusing ring to the right to align the point of proper focus on the distance scale with the index designated with small red "R" in the depth-of-field scale. When making color pictures, follow the manufacturer's recommendations to set focus.



FLASH OPERATION

Automatic operation with Minolta Auto Electroflash CLE

The specially designed Auto Electroflash CLE utilizes your camera's metering system for extremely accurate flash exposure, and its dedicated functions electronically eliminate common setting problems. Further details on this unit can be found in the accessory section of this manual (p.36).

Following is an outline for use of this flash with your CLE camera, but for detailed instructions, refer to its owner's manual:

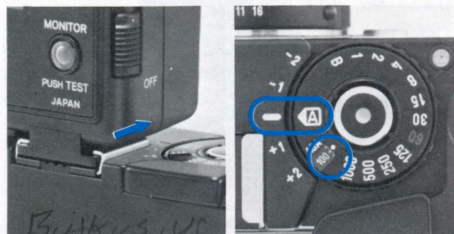

1. Slide flash into the camera's hot shoe.
2. Set camera and flash for ASA of film being used, and turn on camera and flash power switches. Set the camera's shutter-speed/function selector to the automatic setting "A."
3. Set desired lens aperture. The metering system of your camera allows selecting any lens opening.
4. Focus on your subject and determine distance from the lens scale.

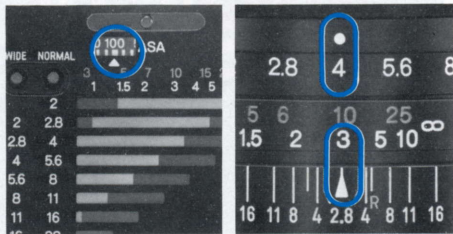

5. Check if flash-to-subject distance is within the automatic operating range for your set lens aperture, using the indicators and scales on the back of the flash.
6. If subject is within range, check monitor lamp on the flash or in the camera viewfinder to see if unit is charged and ready to fire.
7. Release the shutter to take the picture.

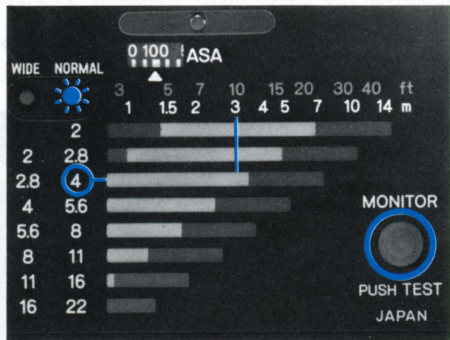

With Minolta X-series Auto Electroflashes

Any of the Minolta X-series flash units can be used on the CLE, with full use of their dedicated functions. Use of these units with the CLE is the same as described in their manuals for use with Minolta XD and XG cameras, except for the flash-ready signal in the viewfinder. Operation is as follows:



1. Slide the flash into the CLE's hot shoe.
2. Set the camera for automatic operation (p.24).
3. Set camera and flash for the ASA of the film in use.
4. Turn flash and camera power switches on.
5. Set flash for automatic operation and set lens aperture according to flashes' owner's manual.
6. Check monitor lamp to confirm that flash is charged and ready to fire.

NOTE

When the flash is charged and ready to fire, the monitor lamp lights and the "60" LED indicator in the viewfinder will blink when you place your finger on the touch switch. However, if the camera's meter selects a shutter speed higher than "60", the LED will not blink and the flash will not fire. If the shutter is released, the exposure will be made in the normal automatic exposure mode. If the "60" LED lights but does not blink, the flash may or may not fire depending on lighting conditions.

7. Release the shutter to take the picture.

NOTES

- When shutter is released with "60" LED blinking, X-sync. is automatically set.
- If the shutter is released before the flash has recycled, exposure will be made in the normal automatic mode.
- When changing from flash operation to normal automatic operation, turn the flash power switch off.
- The flash will also fire if a manual shutter speed from "B" to "60" is set. If a manual speed above "60" is set, the flash will not fire.
- In manual mode no LED indicators will light or blink in the viewfinder.

With other flash units

Other flash units can be used with the CLE as long as they have a hot shoe contact. The CLE camera has no provision for cord-type flash units.

To use other flashes:

1. Attach the flash to the hot shoe of the camera.
2. Set the shutter speed manually (p.27) according to the following table:

Type of flash	Synchronized speed range in seconds – In manual mode
Electronic flash ("strobe")	1 through 1/60, and B
Class M, MF, or FP flashbulbs	1 through 1/15, and B

3. Set lens aperture according to guide number of the flash, or according to the unit's owner's manual.
4. Turn flash and camera on, and check monitor lamp on the flash to confirm when it is charged and ready to fire.
5. Release the shutter to take the picture.





ACCESSORIES

Auto Electroflash CLE

Expressly designed to provide flash-exposure capability to the CLE camera, the Minolta Auto Electroflash CLE with a guide number of 14, perfectly complements your camera in both form and function.

Slipping this sophisticated, yet lightweight and extremely compact flash into the CLE's hot shoe forms a direct interface between the flashes' circuitry and the camera's patented Minolta TTL off-the-film metering. This results in exceptionally accurate flash exposures at any available lens aperture setting.

Dedicated-flash features that automatically set X-sync. at the time of shutter release, confirm flash readiness in the viewfinder, and switch the camera between automatic-flash and normal auto-exposure modes, eliminate most common errors and make taking flash pictures fast and easy.

A built-in wideangle diffuser that provides flash coverage for the CLE's 28mm lens, a special circuit that reduces power to the capacitor after recycling to minimize power drain,

and a bracket contact switch that turns the flash off when it is removed from the camera are features that further enhance this versatile and exclusive flash.



M-Rokkor Interchangeable Lenses

Three lightweight and very compact lenses have been designed and are available for the CLE camera. With focal lengths and speeds of 28mm f/2.8, 40mm f/2, and 90mm f/4, these exceptionally sharp lenses cover the most widely used photographic range.

Each lens is coated by the exclusive Minolta Achromatic process for maximum light transmission and contrast, bayonets quickly and securely to the camera, and has a lens hood that either screws or bayonets onto the lens.

In addition, when any of the lenses are mounted the finder's framing guides are automatically changed to indicate the proper viewing field.



Remote Cord S and L

These electronic remote cords allow instant and vibration-free release of the CLE's shutter. Each securely screws into the remote-release socket on the side of the camera, and greatly facilitates use of the camera on a tripod.

The Remote Cord S is 50cm (approx. 20 in.) long, and the Remote Cord L is 5m (approx. 16-1/2 ft.) in length, which permits remote-location release of the CLE's shutter.



Filters

Minolta 40.5mm-diameter filters are invaluable for light correction and for obtaining various photographic effects. Made of solid glass, ground optically flat in Minolta's own factories to give maximum image quality, each of the eight available filters is mounted in satin-finish metal rings and coated by the exclusive Minolta Achromatic process for maximum light transmission and clarity.



For black-and-white photography, L37 (UV), Y52 (yellow), O56 (orange), and R60 (red) filters are available. For color photography, 1B (skylight), A12 (amber), and B12 (blue) filters are available. There is also a ND 4X (neutral density) filter compatible to either type of photography.

Eyepiece Corrector Vn

To correct the viewfinder for individual eyesight, nine eyepiece lenses (No. 1 to No. 9) can be fitted to the CLE. The No. 1 through No. 5 lenses provided far-sighted correction, and the No. 6 through No. 9 lenses adjust for near-sightedness.



Mini Tripod TR-1

Perfect for table-top support of your compact CLE, the Mini Tripod TR-1 offers great flexibility. It features a locking ball head and rotating socket that allows either vertical or horizontal positioning of the CLE over a full 360° range.

Its light weight and compact size permits easy carrying and storage, as well as its use as a chest pod.



Shoulder Case CLE

Besides the standard case, a specially designed shoulder case is available for the CLE system. This attractive and sturdy case can accommodate your CLE camera, Auto Electroflash CLE, lenses, and other accessories, conveniently and safely.



SPECIFICATIONS

- Type: Compact 35mm rangefinder camera with lens interchangeability, focal-plane shutter, and aperture-priority automatic-exposure control with Minolta Direct (off-the-film-plane) Metering
- Lens mount: Leitz-Minolta CL bayonet type for M-Rokkor interchangeable lenses, 30° rotating angle; cam follower to operate superimposed-image focusing and automatic parallax correction, coupling to automatically change field of view for lens mounted (normal lens: 40mm f/2).
- Auto-exposure control: Special low-voltage, low-current microprocessor circuit, actuated by contact or pressure on shutter-release "touch switch," varies shutter speed continuously and steplessly toward proper exposure according to metering indication at aperture, film speed, and exposure-adjustment set.
Auto-exposure range: EV 3 to 18 (e.g., 1/2 sec. at f/2 to 1/1000 sec. at f/16 at ASA 100 with 40mm f/2 lens)
- Metering: Stop-down TTL off-the-film-plane type by single silicon photo cell with lens-mirror arrangement located in base of camera, measurement for continuous light made from reflective pattern on surface of first curtain for speeds above 1/60 sec. or combination curtain/film surface below 1/60 sec., film surface only for autoflash with dedicated Auto Electroflash CLE
- Shutter: Electronically controlled horizontal-traverse focal-plane type with electromagnetic release; automatic speeds 1/1000 to 1/2 sec. steplessly, manual settings 1/1000 to 1 sec. in steps plus "B" (bulb)
- Film-speed range: ASA 25 to 1600, set by lifting and turning collar on shutter-speed/function selector

Auto-exposure

adjustment: Up to ± 2 EV continuous adjustment of continuous-light and autoflash exposure with 1/2-EV click stop and lock at "A" (zero setting)

Focusing: Rangefinder with central rangefield area that can also function as horizontally oriented split-image spot; superimposed-image and automatic parallax correction coupled to mechanism which follows cam on lens

Viewfinder: Bright-frame type with sliding mask to automatically adjust framing for 40mm and 90mm lenses; stepless shutter speeds indicated by 10 light-emitting diodes, LED over-/under-range indicators; LED at "60" position also blinks as flash-ready signal with special CLE and Minolta X-series Auto Electroflashes; field of view: 85% at 3m with 40mm lens; magnification: 0.58X; effective base length: 28.9mm (actual base length: 49.6mm); power: -0.52D

Flash sync.: Hot shoe for X sync.; electronic flash synchronizes below 1/60 sec. in AE mode, at 1/60 sec. and below for manual settings, will not fire at speeds above 1/60 sec.; Class MF, M and F flashbulbs synchronize at 1/15 sec. and below; special contact receives signal from camera-control contact of Auto Electroflash CLE and X-series units to cause "60" LED in finder to blink when flash capacitor charged with camera at marked auto speeds below 1/60 sec. and set shutter for fixed 1/60 sec. when released; second special contact sends signal from Direct Metering System to Auto Electroflash CLE to control flash duration.

Film advance: By lever with 130° stroke after 30° unengaged movement, film-advance release button for rewinding; advancing-type frame counter

Self-timer: Electronic, activated by pushing shutter-release button with main power switch set to "SELF-TIMER" position, approx. 10 sec. delay time; LED indicator on front of camera blinks to indicate timer on, doubling rate in last 2.5 sec.

Power: Two 1.5v "button" cells, silver-oxide (Eveready EPX-76/S-76 of equivalent) or alkaline-manganese (Eveready A-76 or equivalent) type, contained in camera base power both auto-exposure control and shutter operation when main power switch at "ON;" battery check by LED indicator on front of camera when "B.C." button on bottom of camera is pushed; shutter will not release when voltage too low for proper operation.

Other: 4-slot take-up spool; memo holder and ASA-DIN conversion table on back cover; tripod-socket depth: 5.9mm

Size and weight: 124.5 x 77.5 x 32mm (4-7/8 x 3-1/32 x 1-5/16 in.)
375g (13-7/8 oz.) without power cells

Accessories: M-Rokkor interchangeable lenses, exclusive Auto Electroflash CLE, 50cm (20 in.) Remote Cord S, 5m (16 ft.) Remote Cord L, Minolta L37 (UV) Y52, 1B (skylight), O56, R60, A12, B12, ND4X, 40.5mm-diameter filters, Eyepiece Corrector Vn No. 1 through No. 9 (-4 through +3 diopters), Mini Tripod TR-1, Shoulder Case CLE, Camera Case CLE

Specifications subject to change without notice

CARE AND STORAGE

- As with all high-precision instruments, no part of your CLE should ever be forced at any time. If operation is not as you think it should be, carefully restudy the applicable instructions or consult an authorized Minolta service representative.
- Always keep your camera in its case with the lens capped when not in use.
- Never subject your camera to shock, high heat and/or humidity, water, or harmful chemicals or gases.
- Never lubricate any part of the body or lens.
- Always use a body cap when a lens is not installed on the body. Keep lenses, properly capped front and rear, in their cases when not in use.
- Never touch the shutter curtains or anything inside the front of the body with the fingers. These parts and the inside of the back should be dusted with a soft brush from time to time as necessary, with particular care never to exert pressure on the shutter curtains.
- Never touch lens or other glass surfaces with the fingers. If necessary, remove loose matter from them with a blower lens brush. Use special photographic lens tissue or a soft clean cloth to remove smudges or fingerprints with a gentle circular motion. Only if absolutely necessary, the tissue may be moistened very slightly with not more than one drop of a satisfactory quick-evaporating fluid cleaner specially compounded for photographic lenses. Such fluids must never be dropped directly on the glass surface.
- External camera and lens-barrel — but not glass — surfaces may be wiped with a soft, silicone-treated cloth.
- Never leave the shutter cocked when the camera is to be stored overnight or longer. It is advisable to operate the film advance and release the shutter once or twice from time to time during extended storage.
- Camera should never be put or left in glove compartment or other places in motor vehicles or elsewhere where it may be subject to relatively high temperatures.

- If the camera is not to be used for more than two weeks, the batteries should be removed.
- If the camera is to be stored for a long period of time, body and lens should be returned to their original packing and kept in a cool, dry place away from dust or chemicals, preferably in airtight container with a drying agent such as silica gel.
- Always keep your camera lens capped when not taking pictures. Because there is a possibility of the shutter curtain burning if the camera is turned towards the sun without the lens capped.
- Under extremely cold conditions, the camera may not operate properly. Therefore, keep the camera in a warm place, such as in a pocket or under your coat, when it is used in cold weather. Do not subject the camera to abrupt changes in temperature, as this could cause condensation to form on the inside of the camera.

Minolta Camera Co., Ltd.
Minolta Corporation

Head Office
Los Angeles Branch
Chicago Branch
Atlanta Branch

Minolta Canada Inc.
Head Office
Montreal Branch
Vancouver Branch

Minolta Camera Handels-
gesellschaft m.b.H.
Minolta France S.A.
Minolta (UK) Ltd.

Minolta Vertriebsgesellschaft
m.b.H.
Minolta Nederland B.V.

Minolta (Schweiz) GmbH
Minolta Hong Kong Limited

Minolta Singapore (Pte) Ltd.

30, 2-Chome, Azuchi-Machi, Higashi-Ku, Osaka 541, Japan

101 Williams Drive, Ramsey, New Jersey 07446, U.S.A.
3105 Lomita Boulevard, Torrance, CA 90505, U.S.A.
3000 Tollview Drive, Rolling Meadows, IL 60008, U.S.A.
5904 Peachtree Corners East, Norcross, GA 30071, U.S.A.

1344 Fewster Drive, Mississauga, Ontario L4W 1A4, Canada
7575 Trans Canada Hwy., Montreal, Quebec, H4T 1V6, Canada
1620 W. 6th Avenue, Vancouver, B.C., V6J1R3, Canada

Kurt-Fischer Strasse 50, D-2070 Ahrensburg, West Germany
357 bis, rue d'Estienne d'Orves 92700 Colombes, France
1-3 Tanners Drive, Blakelands, Milton Keynes,
Buckinghamshire MK14 5EW, England

Seidengasse 19, A-1072 Wien, Austria
Zonnebaan 39, Postbox 264, 3600 AG, Maarssebroek-Maarsse,
The Netherlands

Riedhof V, Riedstrasse 6, 8953 Dietikon-Zurich, Switzerland
Oriental Centre Ground Floor, 67-71 Chatham Road South,
Kowloon, Hong Kong

5th Floor, Chiat Hong Bldg. 110, Middle Road, Singapore 0718