

[www.butkus.us](http://www.butkus.us)

**A suggestion:** Unfold and hang up in your studio

# **Sinar F**

## **Operating instructions**

**SINAR LTD SCHAFFHAUSEN CH-8245 FEUERTHALEN**  
Telephone 053/5 45 27

Other instruction books available: SINAR-p and -c, The SINAR Shutter, The SINARSIX,  
The Rapid Adapter, The four-lens unit

Enclosed leaflets: SINAR-f fE, The systematic system (accessories) ZE,  
SINAR codes (order codes and order form) BE



This manual is for reference and historical purposes, all rights reserved.

**This page is copyright© by M. Butkus, NJ.**

This page may not be sold or distributed without the expressed permission of the producer

I have no connection with any camera company

On-line camera manual library

This is the full text and images from the manual. This may take 3 full minutes for the PDF file to download.

**If you find this manual useful, how about a donation of \$3 to: M. Butkus, 29 Lake Ave., High Bridge, NJ 08829-1701 and send your e-mail address so I can thank you. Most other places would charge you \$7.50 for a electronic copy or \$18.00 for a hard to read Xerox copy.**

**This will allow me to continue to buy new manuals and pay their shipping costs.**

**It'll make you feel better, won't it?**

**If you use Pay Pal or wish to use your credit card,  
click on the secure site on my main page.**

PayPal Name Lynn@butkus.org

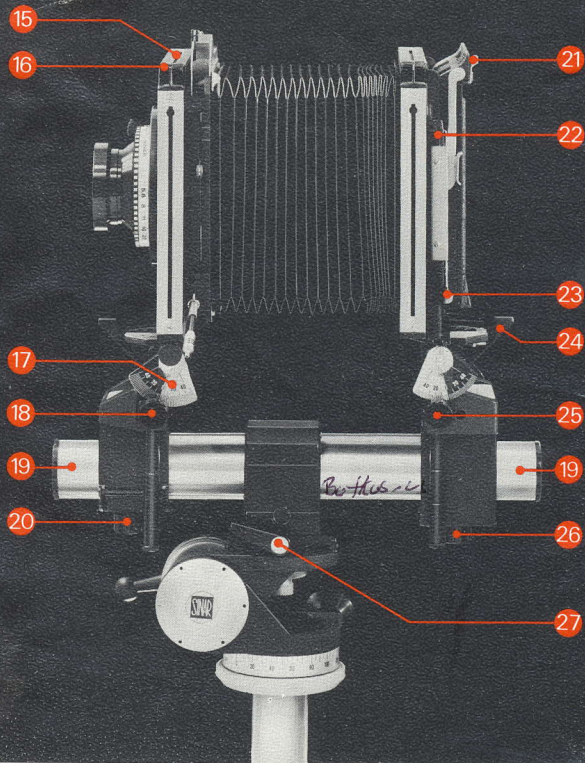
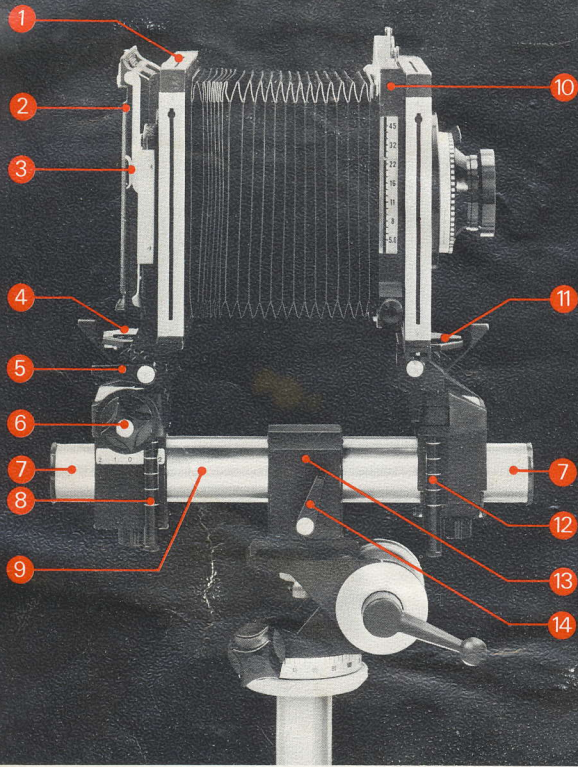

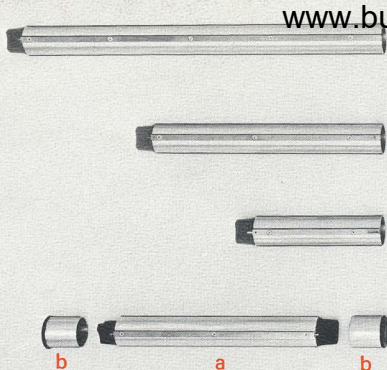
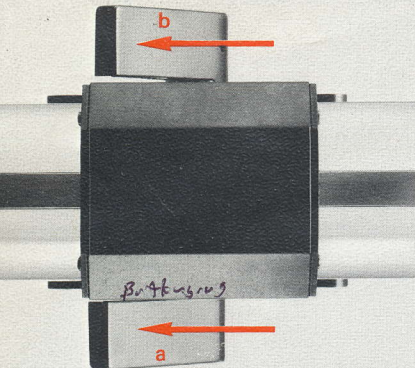

**1** Moving the lever (a) in the direction of the arrow firmly locks the camera on the pan-and-tilt head. Moving the lever (b) in the direction of the arrow locks the camera after balancing and vertical alignment.

**2** The basic rail unit (a) remains on the camera. After unscrewing the caps (b), extension rail lengths of 6, 12 or 18 inches can be screwed on to either end.

**5** With the clamping screw fully unscrewed, the hinged collar of the lens standard can be opened to lift the standard off the base rail.

**6** Engagement stops of the cross front movement: the **white** dot is the centre position for the 4 × 5 inch and 9 × 12 cm format. The **red** dot is the centre position when the standard is used as the lens standard for the SINAR-c with the 8 × 10 inch / 18 × 24 cm back. For the vertical engagement stops see items 8 and 12 overleaf.

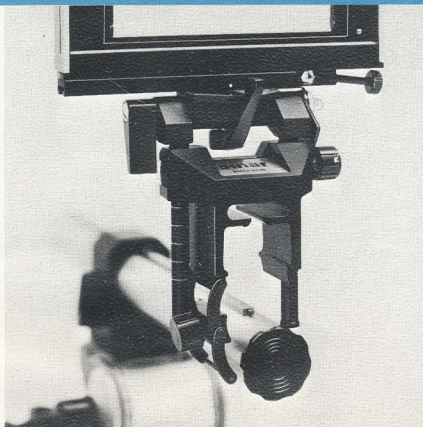

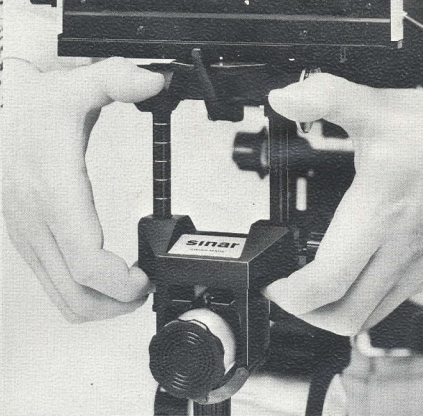
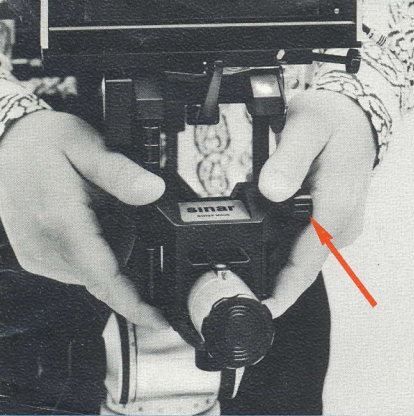

**3** Locking screw for the vertical rise and fall. Note the correct hold to operate the movement.

**4** The correct hold when lowering the standard.

**7** Locking strips for the lens boards, bellows, back, SINAR shutter etc. Insert these upright.

**8** Filter holder and lens hood. These are attached to the filter holder rod as shown.

- The red dots on the format frame and filter holder must line up.
- The bellows is kept detachable at the lens side by the bellows holder I. Release this when using extreme parallel displacements at short extensions.

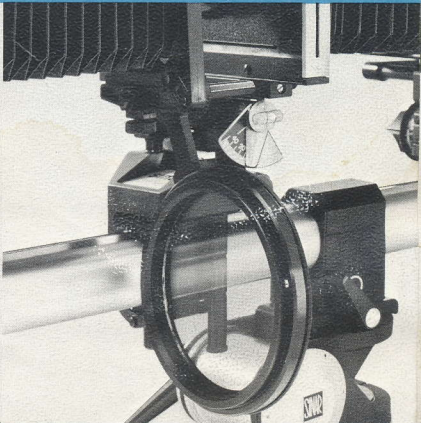
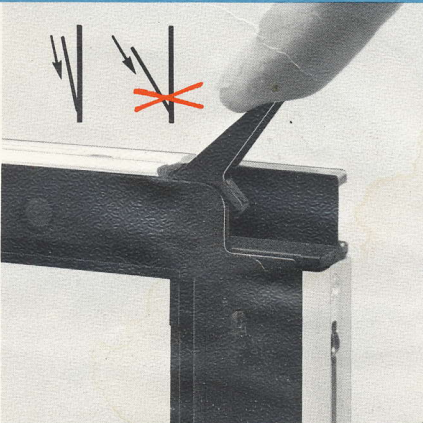



### Setting up the camera

Set up the tripod firmly, with the third leg to the front. First extend the tripod legs before extending the centre column; this provides greater stability.

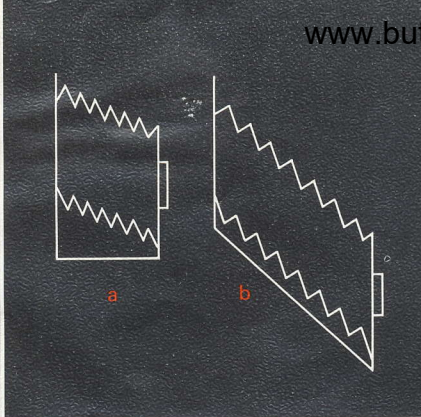

### Parallel displacements

Parallel displacement of the lens and camera back is possible either by direct movement (a) or by indirect adjustment (b). The latter is particularly suitable for long extensions, as the base rail remains lined up with the shooting direction and the centre of gravity of the camera is low. This arrangement permits also extreme displacements without complication as the SINAR-f still swings without yawing in this position.

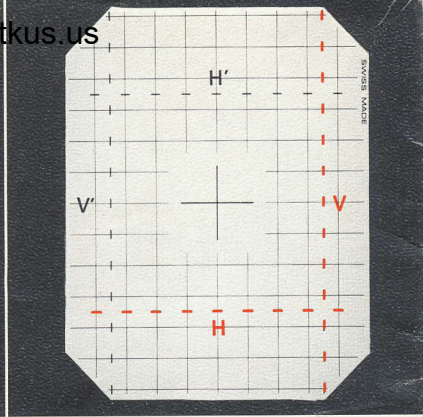

### Swings and tilts for sharpness control in depth

To simplify the control of sharpness distribution in depth, the SINAR-f has unique aids which are based on the proved SINAR two-point focusing principle with great effective base length from one edge of the image to the other. The horizontal tilt axes H and H' as well as the vertical swing axes V and V' are marked on the focusing screen.

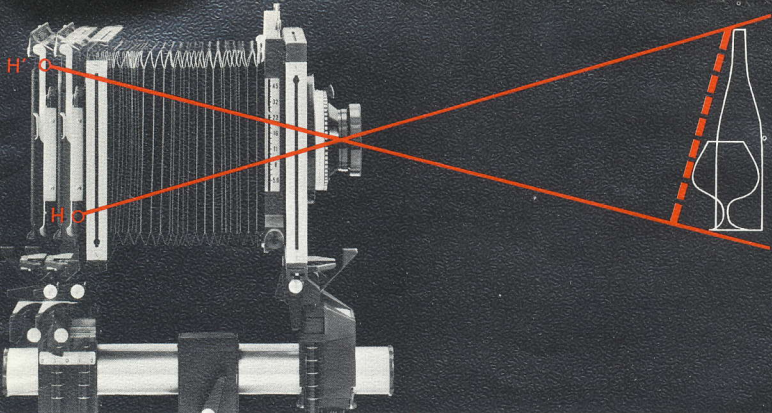

For sharpness control in depth as shown, first focus sharply in the H axis, then in the H' axis (or along V and V' as appropriate). The fine focusing knob of the SINAR-f carries an angle indicator which shows the required tilt angle and direction from the difference between the two focus settings.

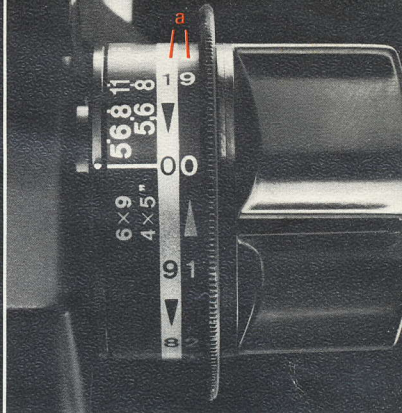

The angle indicator is coupled with the fine focusing drive. The scales (a) show the required degree of tilt. If you have to turn the knob forward (in the direction of the arrow pointing towards the lens, **reducing** the camera extension) the black scale applies; where refocusing involves turning the knob backwards (in the direction of the arrow pointing towards the focusing screen, **increasing** the camera extension) use the white scale.

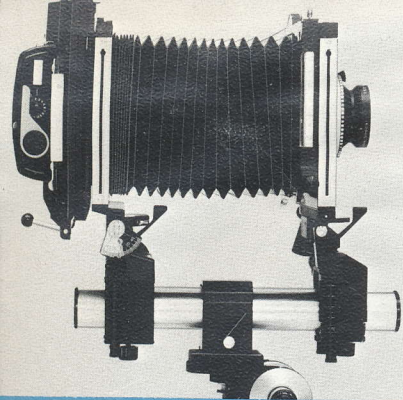

**9** The SINAR Rapid Adapter can be used with the SINAR-f with lenses from 135 mm onwards. In this case reverse the camera back through 180° as shown.

**10** The binocular magnifier provides a brighter screen image; two-eyed viewing facilitates image assessment. The light holder screens off stray light and is also suitable for spectacle wearers. The 2½-times magnifier swings in or out while you are viewing – so your eye remains adapted to the image brightness.

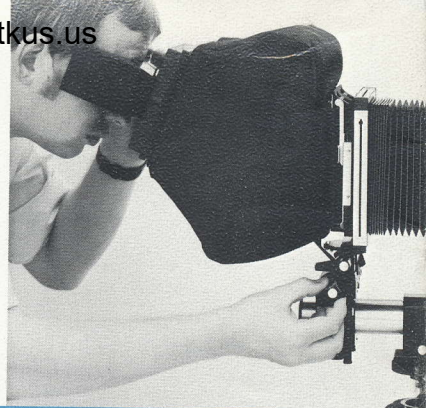

**13** With the SINAR-handy accessories, hand-held shots are also possible with SINAR-f.

Hand grip with cable release for between-lens shutters.

Order code No. 513.21

Hand grip with cable release for the SINAR shutter

Order code No. 513.31

Finder shoe for direct optical finders

Order code No. 531.61

Two-way spirit level

Order code No. 531.71

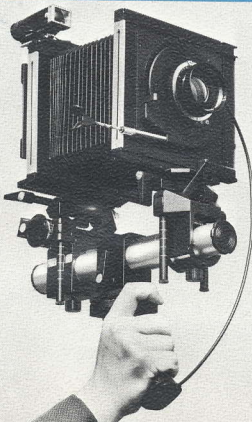

**14 / 15** The SINAR-f easily

1. Remove all external
2. Push the two stop
- Disengage the h
3. Fully raise the le
4. Unlock the tilt m
- down the back
5. Release the tilt
- tighten again.

SINAR Rapid Adapter can be used with the SINAR-f with lenses from 135 mm onwards. In the reverse the camera back can be rotated 180° as shown.

The ocular magnifier provides a larger screen image; two-viewing facilitates image alignment. The light holder shields off stray light and is suitable for spectacle wear. The 2½-times magnifier can be swung in or out while you are viewing – so your eye is adapted to the image distance.

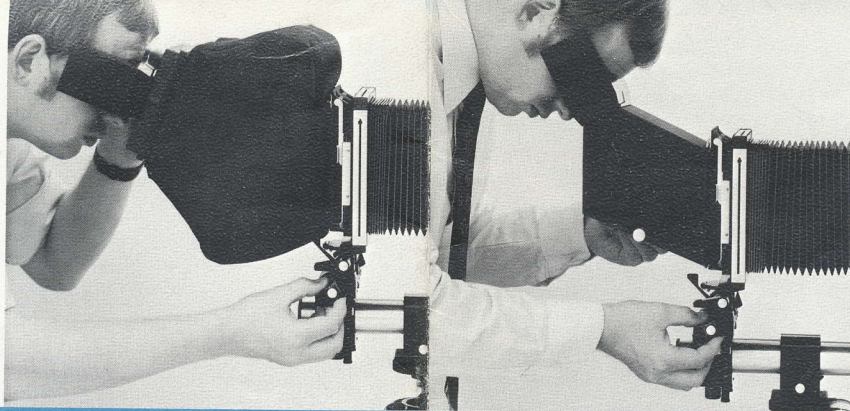

**11** The binocular viewfinder shows the image. The camera is mounted into the patented rail system.

**12** In the wide-angle view, the lens board can be swung out. The lens board remains flat for image sharpness.

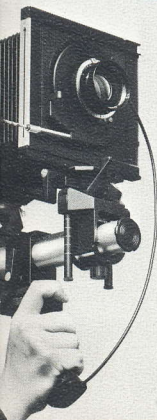

## 14 / 15

The SINAR-f easily folds up. Proceed as follows:

1. Remove all extension units from the base rail.
2. Push the two standards to the outside ends of the base rail. Disengage the bellows at the lens standard.
3. Fully raise the lens standard.
4. Unlock the tilt movement of the rear standard and fully fold down the back onto the rail. Tighten the tilt lock.
5. Release the tilt lock of the lens standard, fold back and tighten again.



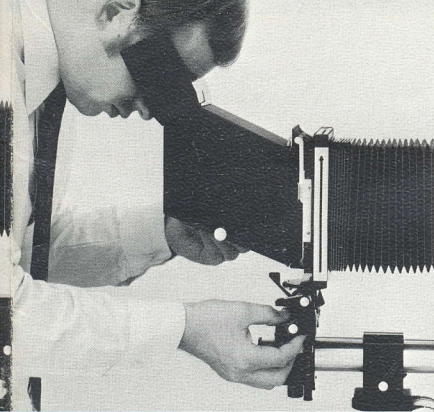

# 11

The binocular reflex shows an upright screen image. This again is brilliant right into the corners thanks to the patented pivoting mirror.

[www.burkus.us](http://www.burkus.us)

# 12

In the SINAR tradition, the SINAR-f ideally copes with wide-angle applications. Lenses of focal lengths from 65 mm can be used without recessed lens boards. The rail clamp can remain between the standards. Pull the wide angle bellows out flat for infinity focusing.

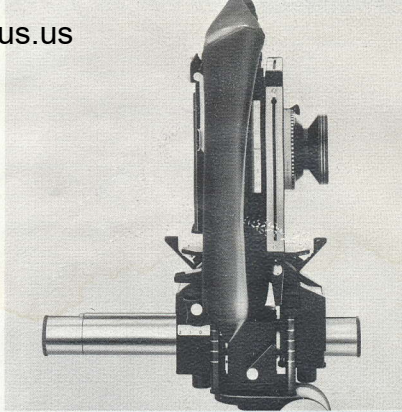

ily folds up. Proceed as follows:

ension units from the base rail.

standards to the outside ends of the base rail.

bellows at the lens standard.

lens standard.

movement of the rear standard and fully fold

onto the rail. Tighten the tilt lock.

lt lock of the lens standard, fold back and

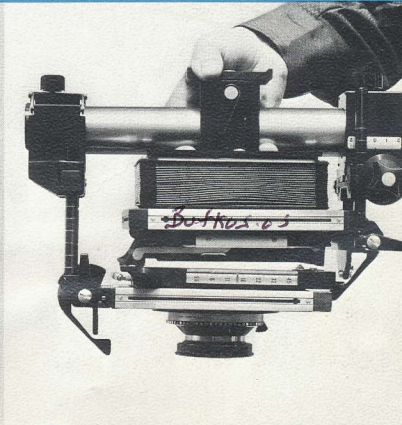
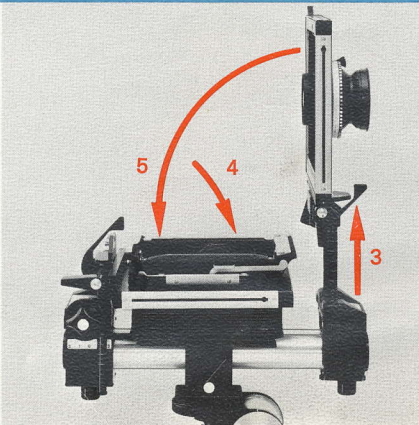

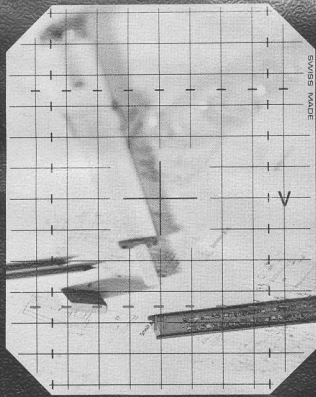
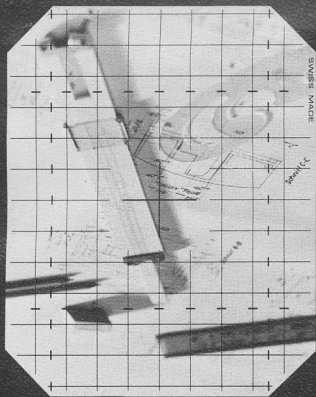

## Procedure for sharpness in depth by tilting or swinging

Carry out the steps in the sequence indicated

Set all camera movements to zero, including the fine focusing adjustment. Focus in the centre of the image with the coarse focusing adjustment, leaving the fine focusing drive at zero.

1. Focus the image as precisely as possible on a point along the H (V) axis with the fine focusing drive. If the main subject point to be focused is not exactly on the H or V axis, simply assume the second focusing point H' (or V') as displaced by the same amount. Deviations are not too critical, and can where necessary be covered by a second readjustment and final compensation.
2. Set the angle indicator to zero. (Push the scale collar S slightly away from the focusing knob to avoid changing the setting of the latter.)

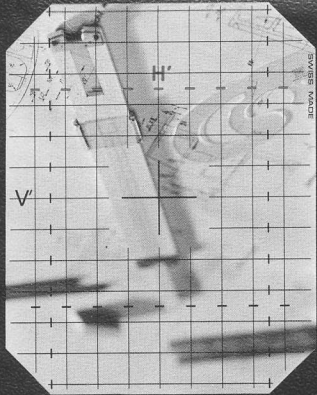

3. Focus on the opposite axis H' (or V'). First of all note the direction in which you turn the knob away from the zero engagement stop to get the subject sharp in the H' (or V') line. If the direction of turning the knob **reduces** the camera extension (in the direction of the arrow pointing towards the lens) use the black scale; if the turning direction **increases** the camera extension (in the direction of the arrow pointing to the focusing screen) use the white scale.

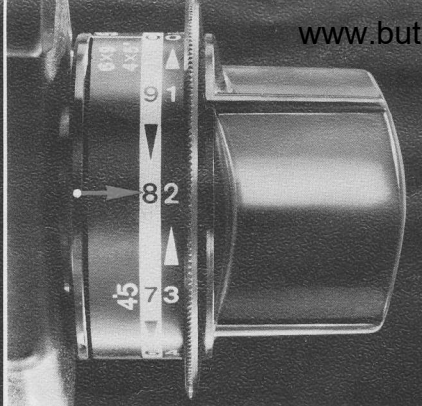

4. Read the value of the required tilt angle on the appropriate scale. In our example this is 8° and, as the movement of the knob increased the extension, use the white scale.\*

\* One full turn of the knob, with the latter turning past the engagement stop, is equivalent to 10°. This must be added to the angle value obtained. For instance, one full turn = 10° + 8° = angle of tilt 18°.

www.butkus.us

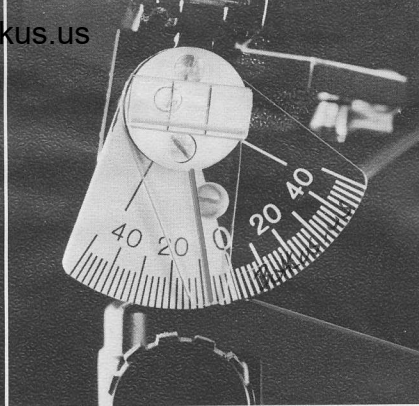

5. Set the tilt angle shown (in this case on the white scale for increased extension) on the tilt scale of the required standard\*\* in the white or black direction as indicated in steps 3 and 4.

\*\* A tilt of the rear standard at the same time changes the perspective of the image. Tilting the lens standard does not change the perspective, but the tilt is limited by the angle of view of the lens.

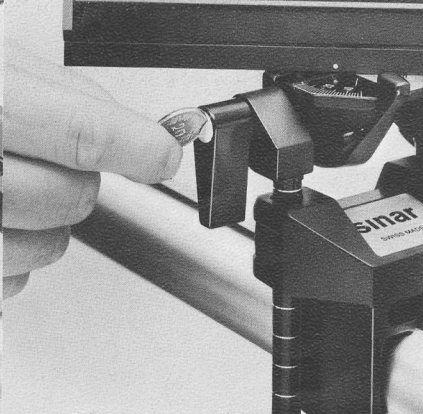
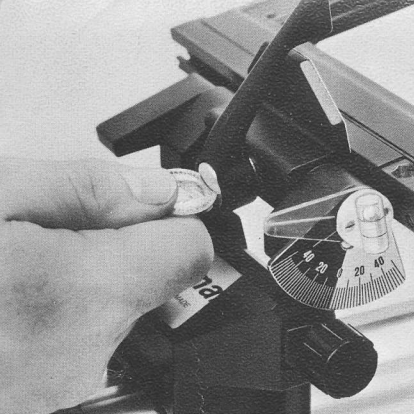

**16** Readjusting the clamping levers. Tilt the standard towards the inside of the camera. Unscrew the screw with a coin. Pull out the lever and readjust along the rack. Tighten the screw again.

**17** Swing the standard. Unscrew the screw with a coin. Pull off the lever from the hexagonal bolt and reset. Tighten the screw again.

**20** Your SINAR-f takes the unique SINAR/COPAL behind-lens shutter (order code No. 521.31) with speeds from  $1/60$  to 8 seconds. It provides standardised exposure times and operation, plus automation of the SINAR-f with over 150 lenses (see leaflet ZE).

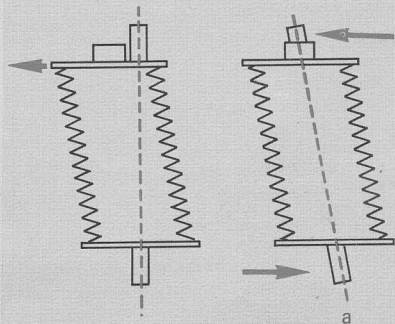
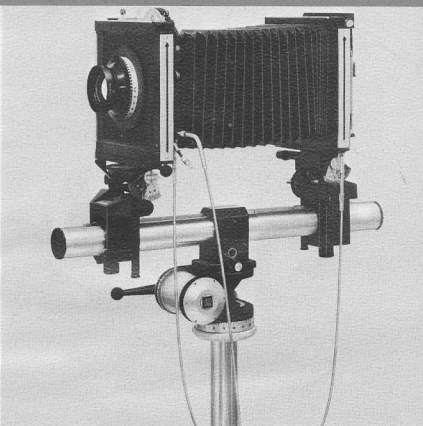

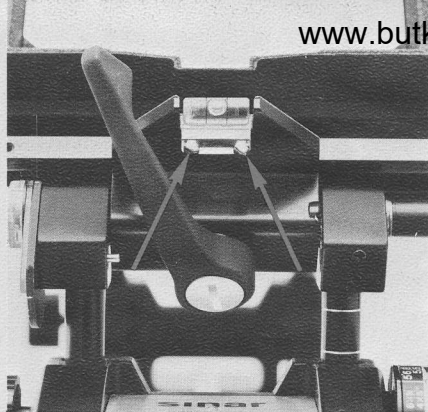
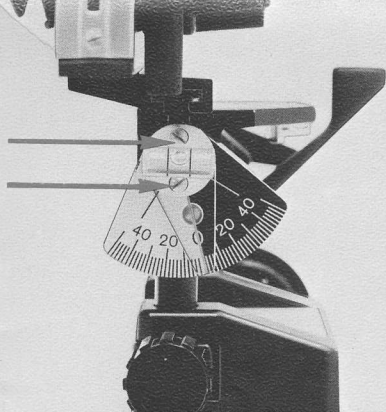

18

**Realigning the spirit level.** If a spirit level should go out of adjustment in time, you can easily reset it. Fully slack off the lower screw and slightly release the upper screw, then align the spirit level and scale index and tighten the screw again.

19

This spirit level can be adjusted by tightening or slacking off one of the two small screws with a spring washer underneath.

21

**Lateral displacement when using the automatic film holder coupling.** When the automatic cable is fitted with the film holder upright and you want to shift the back to the right, carry out this adjustment by moving the lens standard to the left (and not by moving the back to the right). Alternatively, use the indirect parallel displacement to the left as shown in (a).

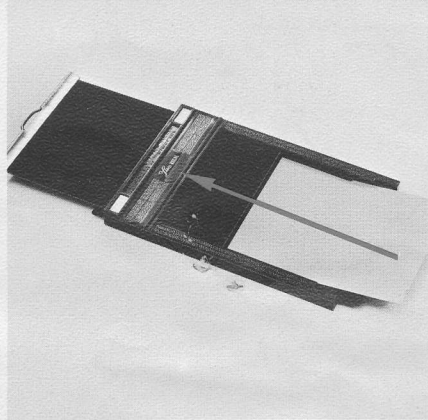

22

### Double sheet film holders

These are easy to load. However, please note:

- Always push sheet films **fully** into the bottom to avoid loss of sharpness and light leaks.
- To ensure optimum film flatness store the films in a dry place. Considerable temperature changes have to be avoided.
- After withdrawing the film holder slide, gently tap the focusing screen to release any stresses in the film.



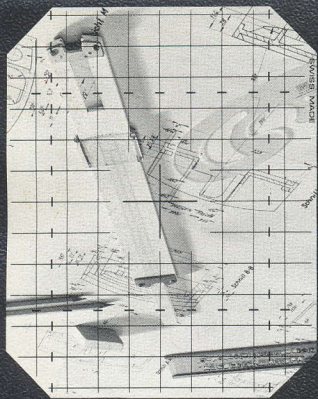

6. Now reset the overall sharpness by movement of the rear standard (image standard).

Final tilt or swing corrections are simplest to carry out on the rear standard. A tilt correction of a few degrees is vital for optimum sharpness, but does not noticeably affect the image perspective unless absolute parallelity of subject lines is important.

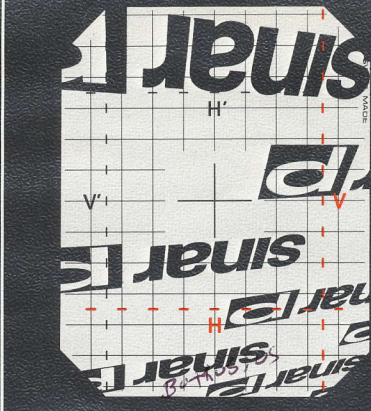

### Simultaneous sharpness control in two directions

First adjust the sharpness distribution between H and H'. Then adjust the sharpness distribution between V and V'. As the standards of the SINAR-f do not yaw during swinging even when the camera is inclined, two-way sharpness control poses no problems.

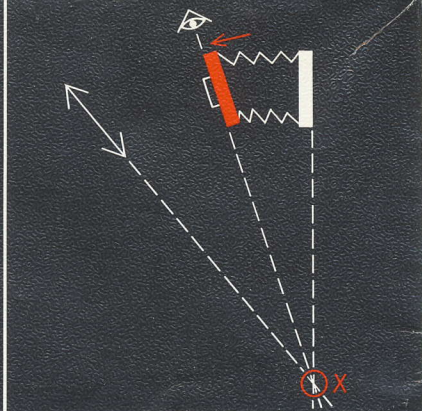

### Sharpness control at close range by tilting the lens

With close-ups even slight changes in the position of the lens standard affect critical sharpness. In this case adjust the lens tilt first by visual sighting as shown, so that the planes of the subject, the lens standard and the image plane meet in a common point.

## The depth of field scale

By using the appropriate tilts and swings according to the coincidence-of-planes principle, you can sharply focus on inclined subject planes even at the full lens aperture.

Increased **depth of field** in front of and behind such a plane depends, however, on stopping down. To indicate the extent of stopping down required, the SINAR-f has two depth of field scales for  $2\frac{1}{4} \times 3\frac{1}{4}$  inch /  $6 \times 9$  cm and for  $4 \times 5$  inch /  $9 \times 12$  cm picture formats respectively.\*

However, it is always best to aim at optimum sharpness distribution in depth first by using the **swing and tilts**. The depth of field scale of the SINAR-f is then used as follows – provided the lens was first focused precisely at the maximum aperture:

\* The depth of field scales are based on the following circles of confusion:

$$\begin{aligned} \text{size } 2\frac{1}{4} \times 3\frac{1}{4}'' / 6 \times 9 \text{ cm} &= 0,075 \text{ mm} \\ \text{size } 4 \times 5'' / 9 \times 12 \text{ cm} &= 0,10 \text{ mm} \end{aligned}$$

### Close-up depth of field

The depth of field scales apply to normal focusing distances up to infinity.

For close-ups, however, the aperture for a given depth of field **can be larger** than shown on the scales. This is useful in view of the greatly increased exposures required at greater camera extensions.

Scale of reproduction	Correction to aperture shown on scale
1:4	Open lens by $\frac{2}{3}$ stop
1:2	Open lens by $1\frac{1}{3}$ stops
1:1	Open lens by 2 stops
3:1	Open lens by 4 stops

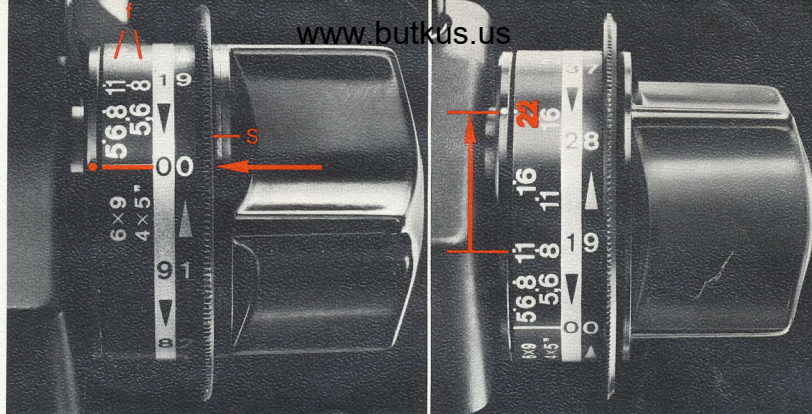

1. First focus on the most important **distant** point (shortest extension) of the subject to be sharp. Push the scale ring S in the direction of the arrow and move the aperture index f opposite the zero mark (engagement stop).
2. Now focus with the fine focusing drive on the nearest significant point required sharp (increased camera extension). Read off the working aperture to be used for the required depth of field and image size on the aperture scale opposite the zero index (f/22 in the example; set this on the lens).
3. Finally turn the focusing knob back to the intermediate value of the **working aperture obtained** for this is the optical centre for the depth of field established. (In our example: the working aperture was f/22 and the focusing centre point is then at a position equal to half this value, i.e. f/11).

## The operating controls

1. Image or focusing screen standard
2. Film holder and focusing screen frame
3. Focusing screen frame lock. To release: depress and push upwards
4. Swing scale (about vertical axis)
5. Tilt clamping lever (horizontal axis)
6. Fine focusing drive with depth of field scale and scale collar
7. End screw cap of base rail
8. Vertical displacement scale with three engagement stops:  
Bottom stop: optical axis of SINAR-f  
Centre stop: optical axis when used with the SINAR-p and SINAR-c  
Top stop: optical axis of SINAR-p and SINAR-c with the 8 × 10 inch / 18 × 24 cm back
9. Base rail (can be extended)
10. **Accessory item:** The SINAR Auto-Aperture Shutter
11. Swing scale (vertical axis)
12. See 8
13. Rail clamp
14. Locking knob to hold the camera in the rail clamp
15. Lens standard
16. Locking strips
17. Tilt scale (about horizontal axis)
18. Locking screw of vertical displacement
19. End screw cap of base rail
20. Locking screw of coarse displacement
21. Attachment system for focusing screen accessories, e.g. the binocular magnifier or binocular reflex magnifier
22. Image plane index
23. Lock for accessories like roll film holders, Polaroid sheet film holders, film pack adapters, etc. (after removal of the focusing screen frame)
24. Locking lever for swings (about vertical axis) and lateral displacement (slightly release lever for swings, release more for lateral displacement)
25. Locking screw of vertical displacement
26. Locking screw of coarse displacement
27. Eccentric locking lever for the pan-and-tilt head movement

You can convert the SINAR-f at any time into the SINAR-c or the SINAR-p. The spare standards now become multi-purpose standards of the SINAR system for increased camera extensions, to support the bellows lens hood, or the SINAR mirror, or can act as a subject stage for copying small objects and for macrophotography.

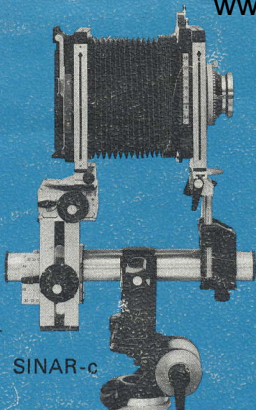

SINAR-c

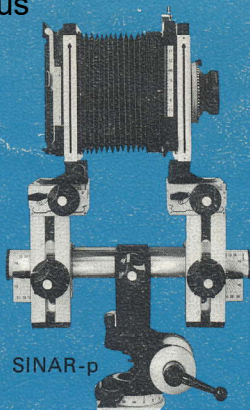

SINAR-p

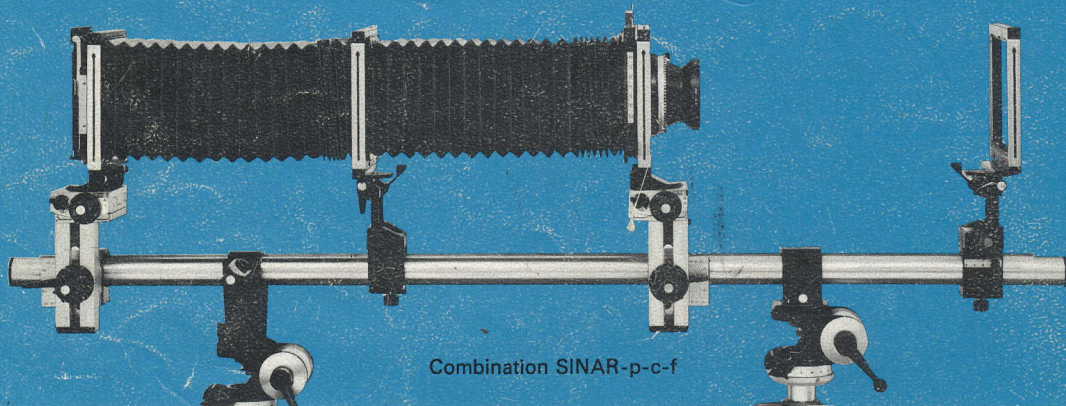

Combination SINAR-p-c-f