



**PLEASE CHECK FOR CHANGE INFORMATION
AT THE REAR OF THIS MANUAL.**

**1503
TIME DOMAIN
REFLECTOMETER**

INSTRUCTION MANUAL

**Tektronix, Inc.
P.O. Box 500
Beaverton, Oregon 97077**

Serial Number _____

070-1865-01
Product Group 27

First Printing OCT 1975
Revised AUG 1982

Copyright ©1975, 1980 Tektronix, Inc. All rights reserved.
Contents of this publication may not be reproduced in
any form without the written permission of Tektronix, Inc.

Products of Tektronix, Inc. and its subsidiaries are
covered by U.S. and foreign patents and/or pending
patents.

TEKTRONIX, TEK, SCOPE-MOBILE, and  are
registered trademarks of Tektronix, Inc. TELEQUIP-
MENT is a registered trademark of Tektronix U.K.
Limited.

Printed in U.S.A. Specification and price change
privileges are reserved.

TABLE OF CONTENTS

	Page		Page
LIST OF ILLUSTRATIONS	ii	Section 3 THEORY OF OPERATION	3-1
OPERATORS SAFETY SUMMARY	iv	Section 4 CALIBRATION PROCEDURE	4-1
SERVICE SAFETY SUMMARY	v	Performance Check	4-2
		Adjustment Procedure	4-4
Section 1 SPECIFICATION	1-1	Section 5 MAINTENANCE	5-1
Section 2 OPERATING INSTRUCTIONS	2-1	Section 6 OPTIONS	6-1
		Section 7 REPLACEABLE ELECTRICAL PARTS	7-1
		Section 8 DIAGRAMS AND ILLUSTRATIONS	8-1
		Section 9 REPLACEABLE MECHANICAL PARTS	9-1

WARNING

THE FOLLOWING SERVICE INSTRUCTIONS ARE FOR USE BY QUALIFIED PERSONNEL ONLY. TO AVOID PERSONAL INJURY, DO NOT PERFORM ANY SERVICING OTHER THAN THAT CONTAINED IN OPERATING INSTRUCTIONS UNLESS YOU ARE QUALIFIED TO DO SO.

LIST OF ILLUSTRATIONS

Fig. No.		Page	Fig. No.		Page
2-1	1503 Time Domain Reflectometer	2-1	5-9	Detail of Plug-in Compartment Seal	5-10
2-2	Battery connector polarity	2-2	5-10	Detail of BNC Connector and Washer	5-10
2-3	Front panel controls	2-3	5-11	Detail of Pushbuttons and Their Shafts	5-10
2-4	Test pulse at reference line	2-4	5-12	Detail of Subpanel Screwhole Sealing	5-11
2-5	TDR display of R_L vs Z_0	2-7	5-13	Detail of Fuseholder Installation	5-11
2-6	X-Y Output Module strap	2-7	5-14	Detail of Fuseholder Caps	5-12
2-7	Open Tip and Ring	2-9	5-15	Application of Sealant to Battery Meter	5-12
2-8	Loading Coil	2-9	5-16	Alignment of Battery Meter	5-12
2-9	Shorted tip and ring	2-10	5-17	Application of Sealant to FOCUS and INTENSITY Controls	5-12
2-10	Building-out network	2-10			
2-11	67-ohm splice at 4000 feet	2-11	5-18	Application of Sealant to FINE Control Bushing	5-13
2-12	Split and re-split pair	2-12			
2-13	Bridge top at 4000 feet	2-13	5-19	Application of Sealant to FINE Control Nut	5-13
3-1	Simplified Block diagram	3-1	5-20	Installation of Distance Meter	5-13
3-2	Sampling diagram	3-2	5-21	Application of Sealant to ZERO REFERENCE Control Bushing	5-14
3-3	Timing diagram	3-4			
3-4	Sampling Circuit timing	3-7	5-22	Application of Sealant to ZERO REFERENCE Control Nut	5-14
3-5	Functional block diagram of the Slow Ramp Generator	3-8	5-23	Application of Sealant to RECORD Toggle-switch Bushing	5-14
3-6	Block diagram of 1503 Power Supply	3-10	5-24	Application of Sealant to RECORD Toggle-switch Nut	5-15
3-7	Chart Recorder logic	3-12			
3-8	X-Y Output Module strap	3-13	5-25	Installation of Rubber Cap-seal on RECORD toggle-switch	5-15
4-1	Power Supply test points and adjustment location	4-5	5-26	Application of Sealant to the 0-dB SET Control Bushing	5-15
4-2	Sampling Efficiency Pulse	4-7			
4-3	First Blow-by Compensation Adjustments	4-8	5-27	Detail Showing Lubrication and Sealing for the Variable Resistor	5-15
4-4	Second Blow-by Compensation Adjustments	4-8	5-28	Lubrication of the O-rings and Sealing for the Cam-switches	5-16
4-5	Fast Ramp test point	4-9			
4-6	External Calibration connection	4-10	5-29	Installation of the POWER SWITCH	5-16
4-7	Fast Ramp test point	4-11	5-30	Lubrication of POSITION Control Knobs	5-17
4-8	External Calibration connection	4-12	5-31	Installation of Knob on Shaft	5-17
4-9	X-Y Output Module strap	4-13	5-32	Lubrication of ZERO REFERENCE Knob	5-17
5-1	DC protection link location	5-2	5-33	Installation of Knob on ZERO REFERENCE Control	5-17
5-2	Transistor and IC lead configuration	5-3			
5-3	Rear view of the HV board	5-4	5-34	Lubrication of FOCUS and INTENSITY Control Knobs	5-18
5-4	Power Transformer wiring	5-5			
5-5	Subpanel, Identification of Parts	5-7	5-35	Sealing of Battery Pack Screwholes	5-18
5-6	Rubber Seals, Edge Sealing for Subpanel	5-8	5-36	Application of Dielectric Type Compound	5-18
5-7	Detail of Implosion Shield Sealing	5-8	5-37	Detail of Front Panel Jacks	5-19
5-8	Front Panel, Identification of Parts for Assembly Steps 8 through 26	5-9	5-38	Detail of X-Y Module Thumbscrews	5-19
			5-39	Sealing of Latch Assembly Screwholes	5-20

LIST OF ILLUSTRATIONS (cont)

Fig. No.		Page
Option		
1-1	Front-panel controls	6-1
Option		
1-2	6-2
Option		
1-3	6-3

OPERATORS SAFETY SUMMARY

The general safety information in this part of the summary is for both operating and servicing personnel. Specific warnings and cautions will be found throughout the manual where they apply, but may not appear in this summary.

TERMS

In This Manual

CAUTION statements identify conditions or practices that could result in damage to the equipment or other property.

WARNING statements identify conditions or practices that could result in personal injury or loss of life.

As Marked on Equipment

CAUTION indicates a personal injury hazard not immediately accessible as one reads the marking, or a hazard to property including the equipment itself.

DANGER indicates a personal injury hazard immediately accessible as one reads the marking.

SYMBOLS

In This Manual



This symbol indicates where applicable cautionary or other information is to be found.

As Marked on Equipment



DANGER — High voltage.



Protective ground (earth) terminal.



ATTENTION — refer to manual.

Power Source

This product is intended to operate from a power source that will not apply more than 250 volts rms between the

supply conductors or between either supply conductor and ground. A protective ground connection by way of the grounding conductor in the power cord is essential for safe operation.

Grounding the Product

This product is grounded through the grounding conductor of the power cord. To avoid electrical shock, plug the power cord into a properly wired receptacle before connecting to the product input or output terminals. A protective ground connection by way of the grounding conductor in the power cord is essential for safe operation.

Danger Arising From Loss of Ground

Upon loss of the protective-ground connection, all accessible conductive parts (including knobs and controls that may appear to be insulating) can render an electric shock.

Use the Proper Power Cord

Use only the power cord and connector specified for your product.

Refer cord and connector changes to qualified service personnel.

Use the Proper Fuse

To avoid fire hazard, use only the fuse of correct type, voltage rating and current rating as specified in the parts list for your product.

Refer fuse replacement to qualified service personnel.

Do Not Remove Covers or Panels

To avoid personal injury, do not remove the product covers or panels. Do not operate the product without the covers and panels properly installed.

SERVICE SAFETY SUMMARY

FOR QUALIFIED SERVICE PERSONNEL ONLY

Refer also to the preceding Operators Safety Summary.

Do Not Service Alone

Do not perform internal service or adjustment of this product unless another person capable of rendering first aid and resuscitation is present.

Use Care When Servicing With Power On

Dangerous voltages exist at several points in this product. To avoid personal injury, do not touch exposed connections and components while power is on.

Disconnect power before removing protective panels, soldering, or replacing components.

Power Source

This product is intended to operate from a power source that will not apply more than 250 volts rms between the supply conductors or between either supply conductor and ground. A protective ground connection by way of the grounding conductor in the power cord is essential for safe operation.

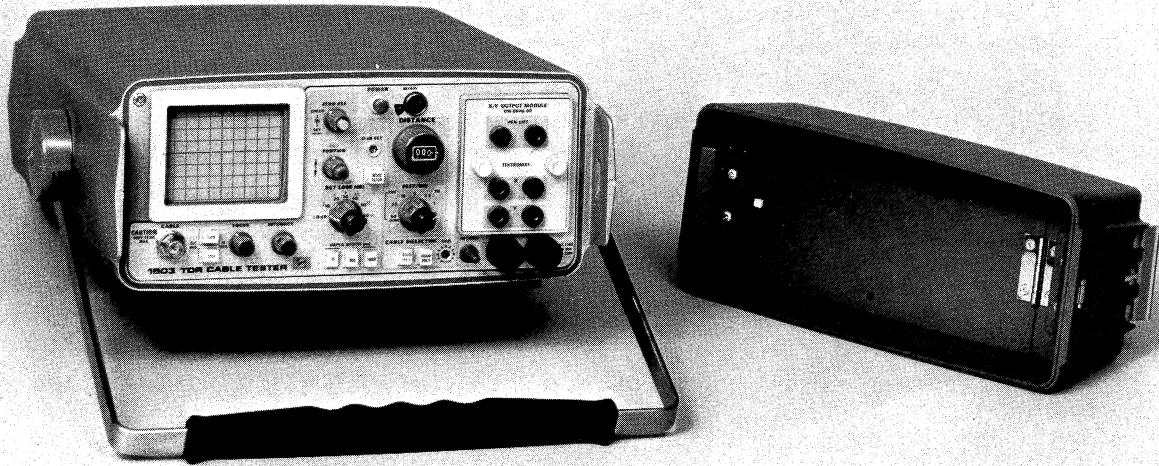

1865-01A

1503 Time Domain Reflectometer.

SPECIFICATION

General Information

The TEKTRONIX 1503 is a portable Time Domain Reflectometer which uses pulse techniques to test cables and provides a visual display of cable faults. The test pulses are transmitted via the CABLE output jack. Reflections are received at the same jack and displayed on the cathode-ray tube (crt).

NOTE

All distances are shown in feet followed by metres in parenthesis. Metric units are not direct conversions from the measurements shown in feet, but represent the calibrated ranges of the metric option 1503. Multiplier settings for the metric options are indicated in the same manner.

Calibrated distance controls allow an operator to examine up to 50,000 feet (10,000 metres) of cable. Up to 7,500 feet (1,500 metres) of cable can be examined with the multiplier control at X10 (X1) from which 50 to 5000 feet (10 metres to 1000 metres) can be displayed across the 10-division horizontal (X-axis) crt scale with an additional 0 to 2500 feet (0 to 500 metres) of distance covered by the DISTANCE dial. Up to 50,000 feet (10,000 metres) of cable can be examined when the multiplier control is at X100 (X10) of which 500 to 50,000 feet (100 to 10,000 metres) can be examined across the crt face. With the FEET/DIV (METRES/DIV) control set at 50, (100) and X100 (X10) up to 50,000 feet (10,000 metres) of cable can be displayed on the crt screen, but in this position the DISTANCE dial is disabled. The horizontal crt scale is calibrated in distance units from 5 feet (1 metre) per division to 5000 feet (1000 metres) per division in a 1-2.5-5 sequence. Distance calibration accuracy on the crt scale is within $\pm 2\%$ of indication.

There are three externally selectable dielectric constants. Two of these are calibrated for foamed polyethylene (FOAM POLY) and solid polyethylene (SOLID POLY). The third is obtained by "default" conditions; both pushbuttons depressed or both pushbuttons released. When both pushbuttons (FOAM POLY and SOLID POLY) are depressed or released, the effective dielectric constant is variable, being controlled by a

screwdriver adjustment labeled "VAR". The fully clockwise position of the "VAR" control sets the dielectric constant for air.

Vertical (Y-axis) deflection of the crt beam is proportional to the amplitude of the reflected signal. The vertical scale is a linear representation of the return pulse and is ordinarily calibrated so that two divisions represent "0 dB" when the reference level is set to "0 dB". The dB reference level is selectable in 7 calibrated steps from 0 dB to 60 dB plus a 0 to 18 dB vernier adjustment.

The transmitted pulse is an impulse signal of approximately 5 V into a 50 Ω , 75 Ω , 93 Ω , or 125 Ω load. Half-sine shaped pulse durations of 10 ns, 100 ns, or 1000 ns are selectable from the front panel. Durations are measured at the half amplitude points.

The 1503 plug-in compartment will accept either the X-Y Output Module or the TEKTRONIX Y-T Chart Recorder. The X-Y Output Module is a standard accessory for the 1503 and provides an interface for an X-Y recorder. The TEKTRONIX Y-T Chart Recorder is an optional accessory. This recorder uses a heated stylus to record on 4 cm wide, heat-sensitive chart paper. The chart recording length represents the entire crt screen and is controlled by the 1503.

The 1503 is a ruggedized portable instrument that can be used in the field as well as in the laboratory. The 1503 meets requirements for a Type III, Class 3, Style A instrument as specified in MIL-T-28800. The 1503 has a ruggedized case that provides protection when the instrument is stored in exposed areas. When the instrument is not being used, the accessories, including the Operators manual, may be packed in the instrument cover and latched tightly on the front of the instrument. Table 1-1 indicates which accessories may be placed in the cover of the 1503.

The characteristics given in Table 1-2 apply over an ambient temperature range from -15°C to $+55^{\circ}\text{C}$ after the instrument has been calibrated at $+25^{\circ}\text{C}$, $\pm 5^{\circ}\text{C}$.

Table 1-1
STANDARD ACCESSORIES FOR THE 1503

Accessory	Tektronix Part Number
2 Replacement Fuses (ac—for front panel)	159-0032-00 (for 115 Vac) or 159-0029-00 (for 230 Vac)
1 Power Cord	161-0066-00
1 Viewing Hood	016-0297-00
1 50 Ω BNC Terminator	011-0123-00
1 X-Y Output Module	016-0606-00
1 Filter, Mesh (crt)	378-0055-00
1 Operators Handbook	070-1864-00
1 Instruction Manual	070-1865-00
1 Cable Assembly	012-0671-00
1 Calculator, TDR Cable Tester	003-0700-01

Table 1-2
ELECTRICAL CHARACTERISTICS

Characteristics	Performance Requirements	Supplemental Information
Impulse		
Width	Selectable: 10 ns, 100 ns, 1000 ns	Measured at half amplitude point.
Accuracy	±20%	
Amplitude		
Terminated	5 V ±20%	
Unterminated	10 V ±20%	
Shape	1/2 sine	
Termination		50 Ω, 75 Ω, 93 Ω ±1%. 125 Ω ±3%.
Jitter	0.2 division maximum	At 5 ft/div (1 m/div)
Graticule Deflection		
Deflection		
Range	+6 to -18 dB	From deflection reference; linear scale on graticule. 0 dB=2 div, displayed signal ≥0.1 div.
Accuracy	±3%	
Deflection Reference	0 to 60 dB	7 steps, 10 dB increments.
Accuracy	±0.1 dB	
Variable	0 to 18 dB	Additive to step increments. Fully clockwise is 18 dB ±2.0 dB.

Table 1-2 (cont)

Characteristics	Performance Requirements	Supplemental Information
Displayed Noise		With proper termination, 10 ns pulse, and pulse completely off-screen.
Aberrations	−30 dB peak-to-peak	Within first three test pulse widths after test pulse.
Random	−80 dB rms	Beyond first three test pulse widths after test pulse.
Low Noise Operation		
Random	−86 dB rms	Three test pulse widths after initial test pulse.
Test Line Conductor		
Coupling		AC coupled
Maximum Input		±400 V (dc + peak ac at maximum frequency of 440 Hz).
Distance Control		
Range	0 to 50,000 feet (0 to 10,000 metres)	
Scales	5 ft/div to 500 ft/div (1 m/div to 100 m/div)	@ X10 (X1) 7 steps, 1-2.5-5 sequence. At 5000 ft/div (1000 m/div) (FIND), the DISTANCE dial is disabled.
Accuracy	±2%	Of display screen from 2nd to tenth graticule line.
Scale Multipliers	X10 and X100 (X1 and X10)	
Accuracy	±2%	From 2nd to tenth graticule line.
Distance Dial		
Range	0 to 2,500 feet (0 to 500 metres) 0 to 25,000 feet (0 to 5,000 metres)	At X10 setting (At X1 setting) At X100 settings (At X10 settings)
Accuracy	2% of reading, ±2 ft @ X10, (±0.2 metres @ X1) ±20 ft @ X100, (±2 metres @ X10)	
Dielectric Scales		
Solid Poly	$V_p/V_{air} = 0.66$	Used where velocity of propagation is 65.9% C (C=speed of light.)
Foam Poly	$V_p/V_{air} = 0.81$	Where velocity of propagation is 81% C.

Table 1-2 (cont)

Characteristics	Performance Requirements	Supplemental Information																		
VAR	$V_p/V_{air} = 0.31$ to 1.0	Activated when both SOLID POLY and FOAM POLY buttons released; or both depressed calibrated for air when VAR control set to Full cw position.																		
Sweep	40 Hz within +0 Hz, -10 Hz	Noise Filter switch "out".																		
Sweep (Chart Recorder Mode)	20 sec/sweep nominal	Varies and is dependent on chart recorder.																		
Chart Tracking	$\pm 2\%$ from 2nd to tenth graticule line																			
Line Voltage	117 Vac $\pm 20\%$, 48 to 410 Hz or 234 Vac $\pm 20\%$, 48 to 410 Hz																			
Line Power	5 W average																			
Battery Pack Operation	At least 5 hours	C size, 9 cell +20°C to +25°C charge and discharge temperature.																		
Full Charge Time		16 hours																		
Typical Charge Capacity Charge Temperature		<table border="1"> <thead> <tr> <th colspan="3">Discharge Temperature</th> </tr> <tr> <th>-15°C</th> <th>+20°C to +25°C</th> <th>+55°C</th> </tr> </thead> <tbody> <tr> <td>0°C</td> <td>40%</td> <td>60%</td> <td>50%</td> </tr> <tr> <td>+20°C to +25°C</td> <td>65%</td> <td>100%</td> <td>85%</td> </tr> <tr> <td>+40°C</td> <td>40%</td> <td>65%</td> <td>55%</td> </tr> </tbody> </table>	Discharge Temperature			-15°C	+20°C to +25°C	+55°C	0°C	40%	60%	50%	+20°C to +25°C	65%	100%	85%	+40°C	40%	65%	55%
Discharge Temperature																				
-15°C	+20°C to +25°C	+55°C																		
0°C	40%	60%	50%																	
+20°C to +25°C	65%	100%	85%																	
+40°C	40%	65%	55%																	
External Recorder Interface for X-Y Recorders																				
Horizontal	0.1 V/div	Source impedance 10 k Ω																		
Vertical	0.09 to 0.13 V/div (adjustable)	Source impedance 10 k Ω																		
Pen Lift																				
Mode 1																				
Source	$V_s = 5$ V Nominal with $R_s = 10$ k Ω																			
Sink	≤ 10 mA	$V_{out} \leq 0.5$ V																		
Mode 2 (inverted Mode 1)																				
Source	$V_s = 5$ V Nominal with $R_s = 10$ k Ω																			
Sink	≤ 0.5 mA	$V_{out} \leq 0.6$ V																		

Table 1-2 (cont)

Characteristics	Performance Requirements	Supplemental Information
Y-T Plug-In Chart Recorder Interface Vertical	0.2 V/div nominal	Source impedance 200 Ω (switched) The TEKTRONIX Chart Recorder, 016-0506-03 is designed to operate with the 1503. The chart uses a heat sensitive stylus to record on 4 cm chart paper. Chart recording length is controlled by the 1503.
Temperature Operating	-15°C to +55°C	At temperatures other than 20°C—25°C, the battery efficiency becomes restricted.
Non-Operating	-62°C to +85°C	With batteries removed. If stored with batteries storage range is -40°C to +55°C.
Humidity	To 100%	
Altitude Operating	10,000 feet	
Non-Operating	50,000 feet	
Vibration	3.0 g, 5 to 55 Hz, Test time 45 min	
Shock, Mechanical Shock, Pulse	15 g, 1/2 sine shock waveform of 11 ms duration. Total of 18 shocks	
Bench Handling Operating	4 drops each face at 4 inches or 45° with opposite edge as pivot	Case on
Non-Operating	4 drops each face at 4 inches or 45° with opposite edge as pivot. Satisfactory operation after drops	Case off
Transit Drop	12 inch drop	
Water Resistance Operating	Splash-proof and drip-proof with cover off and instrument operating.	
Non-Operating	Watertight with three feet of water above top of the case for 1 hour	Cover on
Salt Atmosphere Structural Parts	Withstand 48 hours exposed to 20% solution without corroding	

Table 1-2 (cont)

Characteristics	Performance Requirements	Supplemental Information
Explosive Atmosphere	Operation does not cause ignition of an ambient-explosive-gaseous mixture with air	
Sand and Dust	Operates after non-operating, cover removed, exposed to dust test of MIL-STD-810, Method 510, Proc. I	
Washability	Capable of being washed	
Electromagnetic Compatibility Electromagnetic Interference (EMI)	Meets requirements specified in Table X of MIL-T-28800A	CE01, CS01, CS02, CS06, RE02 (limited to 1 GHz), and RS03, (limited to 1 GHz).
Fungus Inert	Materials used are fungus inert	

Table 1-3

PHYSICAL CHARACTERISTICS

Characteristics	Performance Requirements	Supplemental Information
Weight		
With Panel Cover and Accessories	18.0 pounds (8.2 kg)	
Without Panel Cover and Accessories	16.0 pounds (7.3 kg)	
Height	5.0 inches (12.7 cm)	
Width		
With Handle	12.4 inches (31.5 cm)	
Without Handle	11.8 inches (29.9 cm)	
Depth		
Including Panel Cover	16.5 inches (41.9 cm)	
Handle Extended	18.7 inches (47.4 cm)	

OPERATING INSTRUCTIONS

This section of the manual contains the basic information required for the operation of the 1503 Time Domain Reflectometer. Included is a brief description of the purpose of each front panel control, general operating information, care of the instrument, and basic applications.

FRONT COVER AND HANDLE

The watertight front cover protects the front panel when the instrument is not in use and the cover is latched in place. Special operating instructions are printed on the lid. A canister containing silica gel is mounted on the rear of the instrument to reduce the moisture inside the case.

The cover is released from the unit by pulling forward on the side latches. To secure the cover over the front panel, place the cover into the grooved portion of the front panel and push the latches backward towards the instrument. If the unit is accidentally left on, it will be turned off when the cover is secured over the front panel.

The handle is a friction disc design and will rotate 325°. When the handle is turned so that it is beneath the unit, it will serve as a stand (see Fig. 2-1).

POWERING THE 1503

This equipment has a 3-wire power cord with a 3-contact plug for connection to the power source and to protective ground. The plug protective-ground contact connects (through the cord protective-ground conductor) to the accessible metal parts of the equipment. For electric-shock protection, insert this plug into an outlet that has a securely grounded protective-ground contact.

CAUTION

Do not use this unit with a power inverter that produces a square wave output because power inverters may damage circuitry.

For confirmation that the outlet ground contact is securely grounded, refer to qualified service personnel.

The 1503 operates from the battery supply for a minimum of 5 hours (including 20 chart recordings). If a TEKTRONIX Y-T Chart Recorder is used, the 5 hours operating time will decrease by about 3 minutes for each recording made beyond the 20 specified.



1865-02A

Fig. 2-1. 1503 Time Domain Reflectometer.

Charging the Battery

The battery pack can be charged at any temperature between 0°C and +40°C. It can be operated at any temperature between -15°C and +55°C. For maximum charge capacity, the cells should be charged at +20°C to +25°C.

The battery pack is fully charged in 16 hours when connected to an ac power source and the unit is switched off. The 1503 may be operated while the battery pack is charging, but the charging time will increase. The batteries will not overcharge if the charger is left on longer than 16 hours. Therefore, the 1503 can remain connected to an ac source without damaging the batteries. Approximately once a month or every 15 charge-discharge cycles, the batteries should be charged for approximately 24 hours. Approximately 30 minutes of operating time can be expected from a 1 hour partial charge. For longest battery life, the full 16 hour charge should be completed in preference to a partial charge.

A battery can be damaged by reverse charging. This can occur if an individual cell becomes completely discharged and the current from the other cells flow in a reverse direction through the discharged cell. Such a case can develop due to cell aging, partial charging, or if a cell is replaced. The battery charger uses SCR protection circuits to prevent accidental reverse charging. The SCR protection circuits automatically shut off the instrument whenever battery voltage falls below about 10 V. Do not leave the POWER switch on when the instrument has shut itself down because it will continue to discharge the battery at a slower rate.

A 12 V dc power supply may be substituted for the 1503 battery pack by removing the pack from the unit and connecting the power supply to the terminals inside the battery pack compartment.



When substituting a dc power supply or external battery for the battery pack, be sure the polarity is correct. See Fig. 2-2.

The power pack can be stored at any temperature between -40°C and +55°C with the battery cells either fully or partially charged. The self-discharge rate of the cells increases with increased temperature. A fully charged battery will lose about 50% of its charge in 3 to 4 months if stored at +20°C to +25°C. Therefore, the battery pack should be completely recharged before using if it has been stored without power supplied to its charging circuit for more than a month.

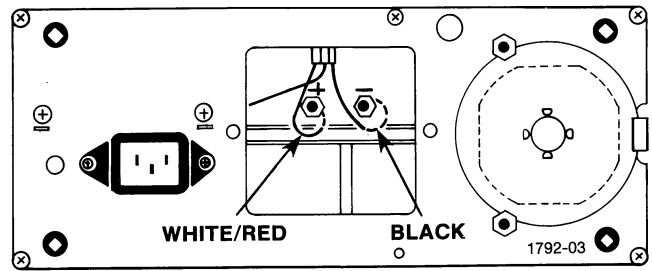

Fig. 2-2. Battery connector polarity.

230 V Operation

The battery charger is factory wired for 115 V ac or 230 V ac if Option 6 is ordered. The standard 115 V ac unit can be changed to 230 V ac operation by rewiring the line transformer. Refer voltage changes to qualified service personnel only.



When the 1503 is wired for 230 V ac, be sure that the two front-panel fuses are changed and the proper plug is installed on the ac cable. Refer to the parts list for the correct parts.

Front Panel Controls (See Fig. 2-3)

- | | |
|------------------------|---|
| 1. CABLE | Precision bnc connector used to transmit the impulse signal into the test cable and receive the reflected signal. |
| 2. Impedance selectors | Two push buttons used to select the 1503 output impedance. 50 Ω pushed in, selects 50 Ω impedance. 75 Ω pushed in, selects 75 Ω impedance. Both pushed in, selects 125 Ω impedance. Both out, selects 93 Ω impedance. |
| 3. FOCUS | Controls sharpness of crt display. |
| 4. INTENSITY | Controls brightness of crt display. |
| 5. POSITION/FINE | Vertical position controls for crt display. |
| 6. ZERO REF CHECK | Push button to check horizontal reference location of test impulse signal on crt. |

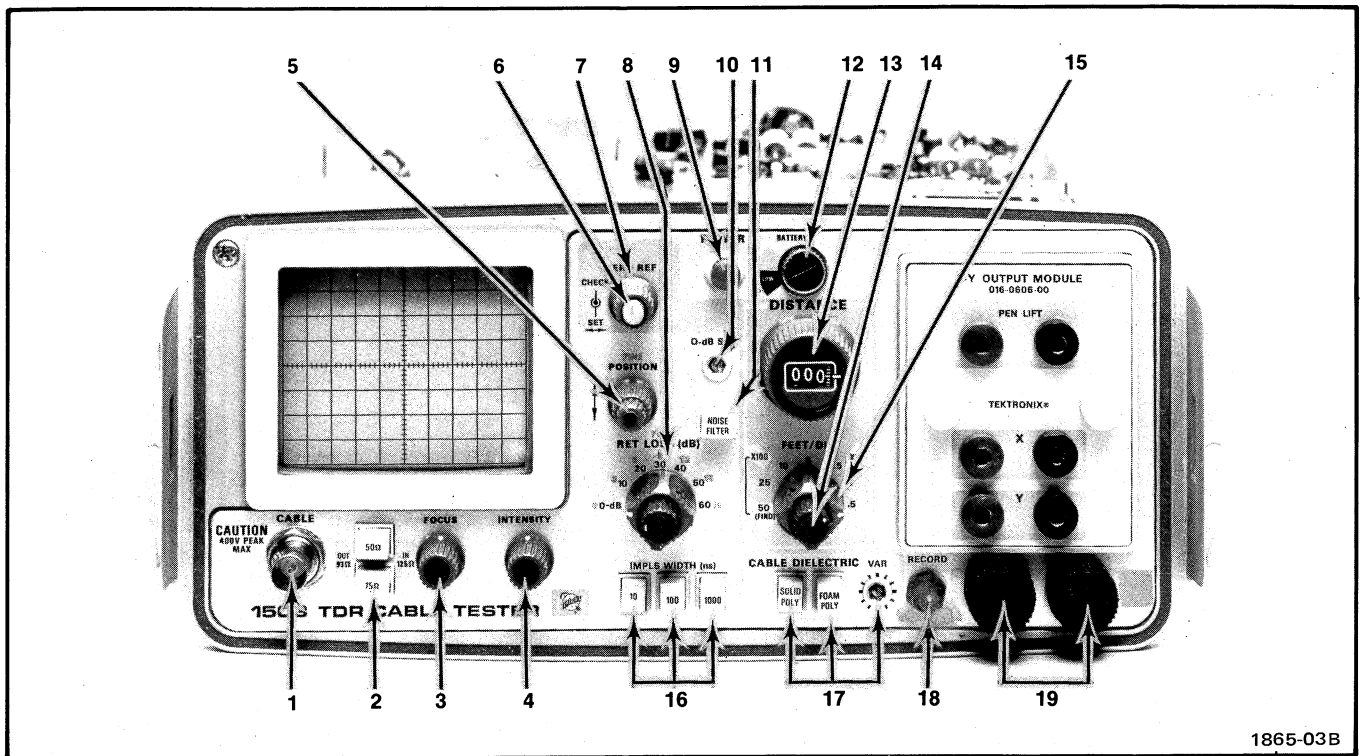

Fig. 2-3. Front-panel controls.

- | | | | |
|-----------------------|---|----------------------------|--|
| 7. ZERO REF SET | Horizontal pulse position control for crt display. Sets test signal edge to a vertical reference line on the crt when the DISTANCE dial is at 000 or ZERO REF CHECK button is pushed. | 13. DISTANCE | Indicates the distance from 1503 to a point on the test cable; 0 to 2500 feet (0 to 500 metres) at X100 (X10). Disabled when the FEET/DIV (METRES/DIV) control is set to 50 (100) and the multiplier is set to X100 (X10). |
| 8. RET LOSS (dB) FINE | Selects dB reference level of the reflected signal. 0-dB to 60-dB in seven calibrated steps. FINE adds 0—18 dB to selected steps. | 14. X10 (X1)
X100 (X10) | Two-position switch for X10 (X1) or X100 (X10) multiplier. Affects both DISTANCE dial and FEET/DIV (METRES/DIV) control. |
| 9. POWER | Pull-on, push-off switch. Does not affect battery charging circuits. | | |
| 10. 0-dB SET | Screwdriver adjust for 0-dB reference level. Used to set amplitude of test pulse. | 15. FEET/DIV (METRES/DIV) | Selects horizontal deflection factor.
X10 (X1) = 5 to 500 feet/div (1 to 100 metres/div).
X100 (X10) = 50 to 5000 feet/div (10 to 1000 metres/div). |
| 11. NOISE FILTER | Reduces displayed noise. Display sweep rate is reduced by a factor of ten. | | |
| 12. BATTERY | Indicates relative charge of power pack. | 16. IMPLS WIDTH | Selects width of test impulse for 10, 100, or 1000 ns. |

Operating Instructions—1503

17. **CABLE DIELECTRIC** Two push buttons and a screwdriver adjust. Selects proper velocity of propagation. VAR control is activated when both buttons are pressed or released. VAR control is set to air when fully clockwise. VAR control has reference marks every 30° to indicate relative propagation constants.
18. **RECORD** Two-position toggle switch. Used to start an X-Y Recorder or TEKTRONIX Y-T Chart recorder. Push up and hold momentarily to pre-heat stylus; then release to start Chart recorder.
19. **AC LINE FUSES** Protection fuses for the battery charger circuits.

Plug-in Modules

1. **X-Y OUTPUT MODULE** The standard plug-in module for the 1503. Used to interface to an external X-Y chart recorder.
- X, Y and PEN LIFT** Three dual sets of front-panel jacks are used to supply horizontal, vertical, and pen lift information to an external X-Y Recorder.
2. **Y-T CHART RECORDER** An optional Tektronix Chart Recorder which replaces the X-Y OUTPUT MODULE.
- STYLUS POSITION** Screwdriver adjustment to adjust stylus to the same level as the crt display when the RECORD switch is in RECORD position.

OPERATIONAL CHECKOUT

1. Use the step-by-step procedure for an operational check of the 1503. First set the controls as follows:

FOCUS	Midrange
INTENSITY	Fully clockwise
ZERO REF	Fully clockwise
RET LOSS (dB)	0 dB
DISTANCE	000
NOISE FILTER	Out
FEET/DIV	5
(METRES/DIV)	(10)

X10-X100	X10
(X1-X10)	(X1)
CABLE DIELECTRIC	SOLID POLY
IMPLS WIDTH	100
50/75 Ω	50 Ω

2. Adjust the INTENSITY & FOCUS control for a clear bright trace.
3. Adjust the POSITION control to set the trace on the horizontal center line.
4. Attach the 50 Ω terminator to the CABLE connector.
5. Turn the ZERO REF SET button ccw until the test pulse leading edge is located on a vertical reference line. The vertical reference line may be any vertical line you choose on the crt graticule. Adjust the 0-dB SET control for a two division display.

NOTE

Always use the leading edge at the base line of the pulse for setting reference. (See Fig. 2-4.)

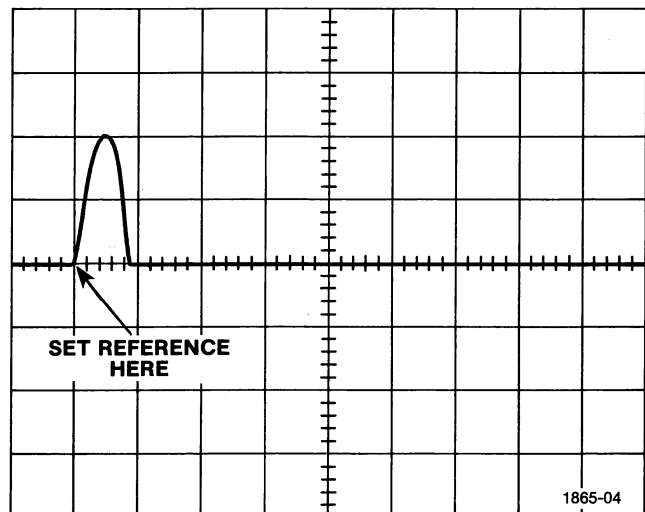

Fig. 2-4. Test pulse at reference line.

6. Adjust the ZERO REF SET button throughout its range to see that the test pulse edge can be set on any vertical graticule line. Set the test pulse edge on the vertical reference line.

7. Set the DISTANCE dial to 010, press the ZERO REF CHECK button and check that the test pulse edge returns

to the vertical reference line of the graticule. Reset the DISTANCE dial to 000.

8. Change the RET LOSS control to 10-dB and adjust the POSITION control so that the horizontal baseline is on the bottom crt graticule line.

9. Press the NOISE FILTER button and check for a reduction in displayed noise as well as a reduction in scan rate. Reset the RET LOSS switch to 0-dB, release the NOISE FILTER button (by depressing a second time).

10. Press IMPLS WIDTH (ns) 1000 and check for a 9 division (within 20%) wide pulse.

11. Press IMPLS WIDTH (ns) 10 and set FEET/DIV (METRES/DIV) to .5 (1) and check for a slightly greater than one division wide pulse.

12. Lift up and hold the RECORD switch. Check that a bright spot appears at left edge of the crt.

13. Release the RECORD switch. The spot will slowly trace the waveform. When the scan is complete the 1503 will automatically return to its normal mode.

Connecting a Test Cable to the 1503



Voltages up to 400 V may be expected on long twisted-pair lines. These voltages may be present on the front panel of the 1503. The optional isolation transformer (013-0169-00) is recommended to avoid electrical shock to the user.



Voltages higher than 400 V peak or lower voltages at frequencies higher than 400 Hz may damage the Pulser and/or Sampler circuits of the 1503.

Connect cables, to be tested by the 1503, to the CABLE connector on the front panel. Cables of any impedance may be tested by adjusting the 0-dB SET control and/or using other than 2 crt divisions as the 0-dB reference. However, tests at long ranges may be degraded.

Table 2-1

OPTIONAL ACCESSORIES FOR THE 1503

Accessories	Tektronix Part Number
Adapter Assembly, Isolation Transformer	013-0169-00
Terminator, 75 Ω BNC	011-0102-00
Connector, BNC Female-to-Clip Leads	013-0076-00
Adapter, Camera (Extension)	016-0327-01
Chart Recorder	016-0506-03
Chart paper	006-1658-00 or 01
Connector, BNC Female-to-GR	017-0063-00
Connector, BNC Male-to-GR	017-0064-00
Adapter, 50/125 Ω	017-0090-00
Adapter, 50/75 Ω	017-0091-00
Adapter, 50/93 Ω	017-0092-00
Connector, BNC Female-to-UHF	103-0015-00
Connector, BNC Female-to-Dual Banana Plug	103-0090-00
Connector, BNC Male-to-Male	103-0029-00
Connector, BNC Male-to-UHF Female	103-0032-00
Connector, BNC Male-to-Dual Binding Post	103-0035-00
Connector, BNC Male-to-N Female	103-0058-00
Connector, BNC Female-to-Dual Banana Plug	103-0090-00

Locating a Discontinuity in a Cable

The DISTANCE dial and the FEET/DIV (METRES/DIV) control make it possible to evaluate cables as long as 50,000 feet (10,000 metres), subject to their transmission quality. The entire length can be displayed directly on the crt if desired. If a chart recorder is used, only that portion of the trace seen on the crt will be recorded on the graph.

To check cables using only the crt display, the FEET/DIV (METRES/DIV) control and the X10-X100 (X1-X10) control must be set so that the crt display window is longer than the cable. For example, if the cable is 1500 feet (500 metres) long, set the FEET/DIV (METRES/DIV) control to 25 (10) and the multiplier control to X10 (X10).

Operating Instructions—1503

This setting of the FEET/DIV (METRES/DIV) control assures that the return signal will appear in the display window. Measure the distance between the test pulse start and the return pulse start.

To more accurately locate the discontinuity, set the FEET/DIV (METRES/DIV) control to a lower setting. (The return pulse does not need to be in the display window.) Adjust ZERO REF SET button so that the test pulse rise is set at a convenient vertical reference graticule line. The ZERO REF SET control may have to be readjusted when changing the FEET/DIV (METRES/DIV) control.

NOTE

Always use the leading edge at the base line of the test/return pulses for setting the reference. (See Fig. 2-4.)

Now turn the DISTANCE dial clockwise until the return pulse is located on the reference graticule line. The reading on the DISTANCE dial times the multiplier gives the length from the CABLE connector to the discontinuity.

NOTE

The dB reference may have to be increased to observe the reflection.

The CABLE DIELECTRIC push buttons allow the 1503 to accurately locate discontinuities in cables with various relative propagation velocity constants (V_p). The SOLID POLY button is calibrated to check solid polyethylene dielectric which has a V_p of 0.66. The FOAM POLY button is calibrated to check foam polyethylene which has a V_p of 0.81. When both buttons are either in or out, the effective dielectric is variable from 0.31 to 1.00 and is controlled by the screwdriver adjustment control VAR. In the fully clockwise position it is calibrated for air dielectrics (V_p 1.00).

Evaluating a Discontinuity

The RET LOSS control determines the vertical deflection that can be seen on the crt, or recorded on a graph if a chart recorder is used. The control is calibrated to measure the dB loss of the return pulse amplitude relative to the test pulse amplitude. The screwdriver adjustment, 0-dB SET, is used to set the amplitude (number of crt graticule divisions) of the test pulse. The RET LOSS control is then adjusted so that the return pulse amplitude is the same as the 0-dB reference amplitude. The return loss in dB is then read directly from the RET LOSS control settings.

The mathematical definition of RET LOSS is $20 \log \rho$; where ρ , the reflection coefficient rho, is given by:

$$\rho = \frac{Z_L - Z_0}{Z_L + Z_0}$$

where Z_0 is the cable impedance and Z_L is the impedance of the discontinuity, assuming no cable loss.

Fig. 2-5 shows the two parts of a TDR display appropriately labeled to identify the test and return voltage signals. When the return loss = ∞ dB, the cable is terminated by a resistance equal to its characteristic impedance (Z_0), since a perfectly matched cable ($R_L = Z_0$) gives no reflection. When the return loss equals 0 dB with a positive return pulse, the cable has an open termination ($R_L = \infty \Omega$). When the return loss equals 0 dB with a negative return pulse, then the cable is terminated with a short ($R_L = 0 \Omega$).

NOTE

Care must be taken to account for cable loss which is assumed to be zero in the example shown in Fig. 2-5. Actual discontinuities are shown later in this section.

Cables with a characteristic impedance other than 50, 75, 93, or 125 Ω can be evaluated by adjusting the 0-dB SET control to correct the test pulse for two divisions then proceed as normal. Positive or negative re-reflections will be observed, however, due to the impedance mis-match.

The NOISE FILTER button can be used to reduce the noise displayed on the crt. The reduction in noise is accomplished by changing the time constant of the R-C filter and is accompanied by a slowing of the sweep rate.

1503 ACCESSORIES

Plug-ins

The 1503 plug-in compartment will accept either the X-Y OUTPUT MODULE (provided as a standard accessory) or the TEKTRONIX Y-T Chart Recorder (Part Number 016-0506-03) which is supplied with Option 4 instruments.

Using an X-Y Recorder

The X-Y OUTPUT MODULE may be wired for either a positive or negative pen lift signal. Before using the X-Y OUTPUT MODULE, be sure that the pen lift circuit on the etched circuit board is properly connected. Fig. 2-6 shows the proper connection for either a positive or negative pen lift signal.

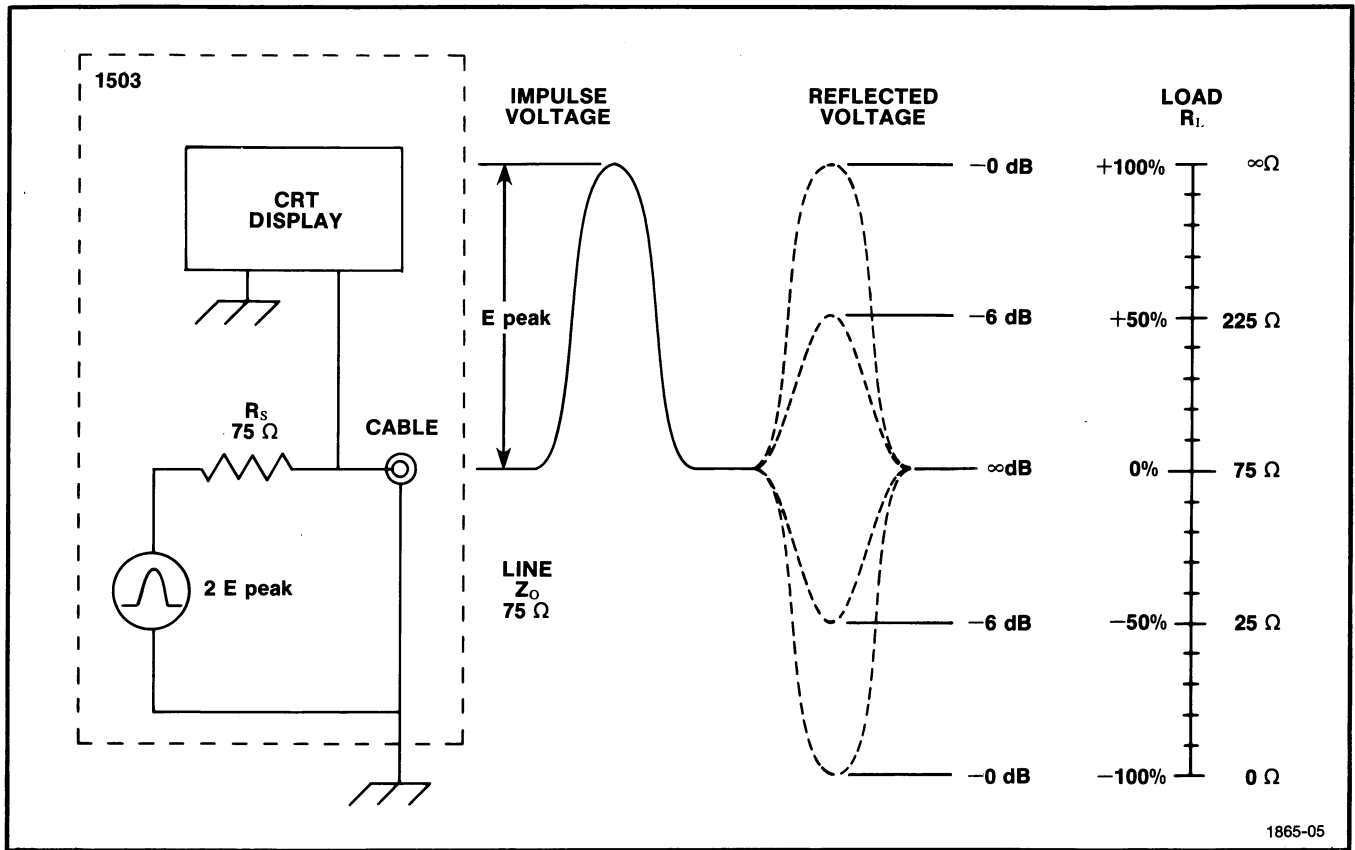

Fig. 2-5. TDR display of R_L vs Z_o .

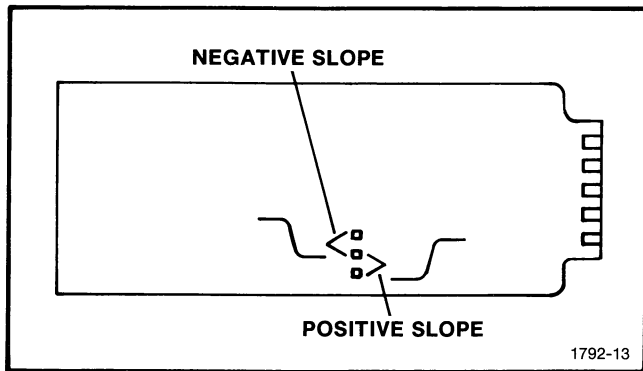

Fig. 2-6. X-Y Output Module strap.

An X-Y recorder can be used with the 1503 by connecting it to the X-Y OUTPUT MODULE when it is plugged into the 1503. Connect the X, Y, and PEN LIFT inputs of the recorder to the corresponding jacks of the X-Y OUTPUT MODULE. See the manual provided with the recorder for further information on its use.

Mesh Filter for the crt

A mesh filter is provided with the 1503 which makes viewing of the crt easier when the unit is being used in the sunlight. This filter is placed over the crt by sliding it onto the slots of the crt bezel.

Viewing Hood

Another accessory provided with the 1503 for light shading is a viewing hood. This unit can be installed over the crt by sliding it down over the crt bezel sides. The mesh filter must be removed before the viewing hood will connect to the crt bezel.

Using a Camera with the 1503

If a Camera Adapter is attached to the crt bezel of the 1503, a C-30B/31B camera can be used to take photographs of the crt display.

Operating Instructions—1503

Nominal C-30B/31B camera settings are:

<i>f</i> /stop	5.6-11
time	1 s
magnification	1.2 (fixed at 0.5 in C-31B)
focus	as necessary

Battery Care

To charge the batteries, connect the 1503 to a suitable ac power source. The battery pack will be fully charged in 16 hours. Approximately 30 minutes of operating time can be expected from a one hour partial charge. The batteries will not overcharge if left on longer than 16 hours so the 1503 can remain connected to an ac source without damaging the batteries.

Reverse charging a battery can damage it. Reverse charging can occur if an individual cell becomes discharged before the others. Such a case can develop due to cell aging, partial charging, or if a cell is replaced. If a cell becomes completely discharged, it is possible for it to become reverse charged by the current from the stronger cells. The battery charger is designed, using SCR protection circuits, to prevent deep discharge. The SCR protection circuits automatically shut off the instrument whenever battery voltage falls below about 10 V. Do not leave the POWER switch on when the protection circuit has shut down the instrument because there is still a slight drain on the battery.

To obtain longer battery life, the full 16 hour charge should be completed in preference to a partial charge cycle whenever possible. In addition, approximately once a month or every 15 charge-discharge cycles (whichever occurs first), the batteries should be charged for approximately 24 hours.

The battery pack can be charged at any temperature between 0°C and +40°C and discharged (operated) at any temperature between -20°C and +55°C, but for maximum charge capacity, the cells should be charged at +20°C to +25°C. For more information refer to the Specification section of the Instruction Manual.

The power pack can be stored at any temperature between -40°C and +55°C with the battery cells either fully or partially charged. The self-discharge rate of the cells increases with increased temperature. A fully charged battery will lose about 50% of its charge in 3 to 4 months if stored at +20°C to +25°C. Therefore the battery pack should be completely recharged if it has been stored for more than a month.

The 1503 has been made with a ruggedized case that is suitable to provide protection when stored in exposed areas. When the instrument is not being used, the accessories, including the Operators Handbook, should be packed in the instrument cover and the cover latched on the front of the instrument.

Instrument Storage

The 1503 can be stored in temperatures between -62°C and +85°C, but if the temperature is below -40°C or exceeds +55°C, the batteries must be removed and stored in a location where the temperature is between -40°C and +55°C.

MEASUREMENT EXAMPLES

This section shows diagrams and results of checking telephone-type twisted pair lines with the 1503. Errors in impedance matching are the most misleading to the user and must be understood for proper evaluation of the crt display. The notes with each diagram are very condensed. Refer to TEKTRONIX application note on testing telephone long lines for more detail.

WARNING

Voltages up to 400 V may be expected on long twisted pair lines. These voltages may be present on the front panel of the 1503. The optional isolation transformer (013-0169-00) is recommended to avoid electrical shock to the user.

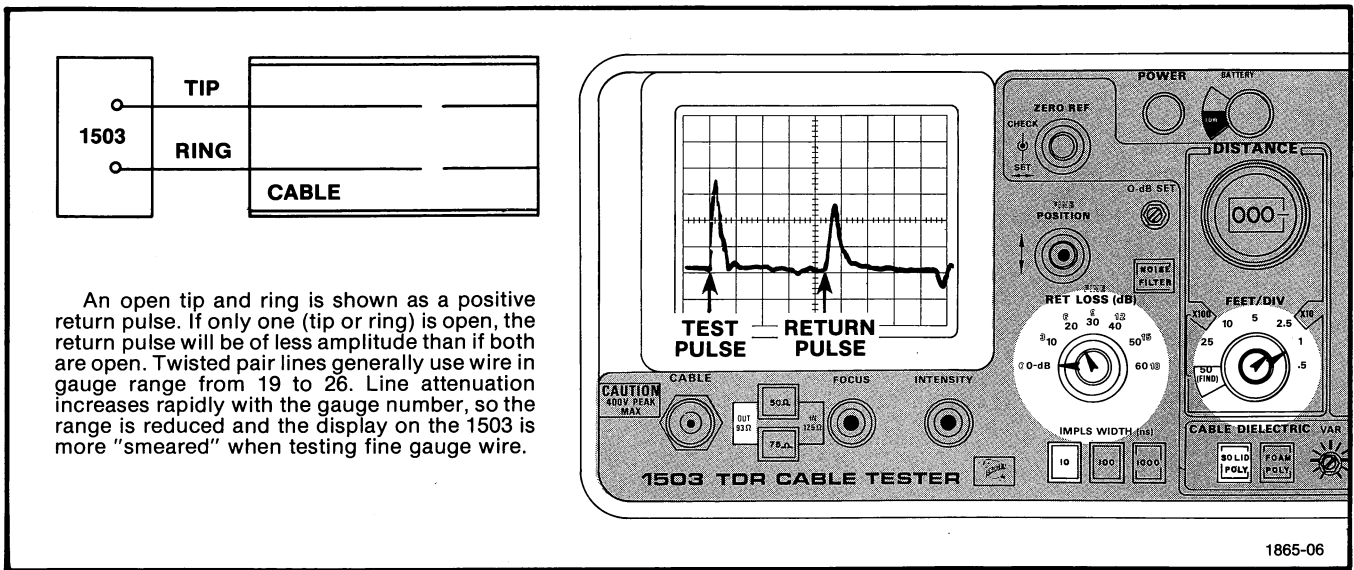

Fig. 2-7. Open Tip and Ring.

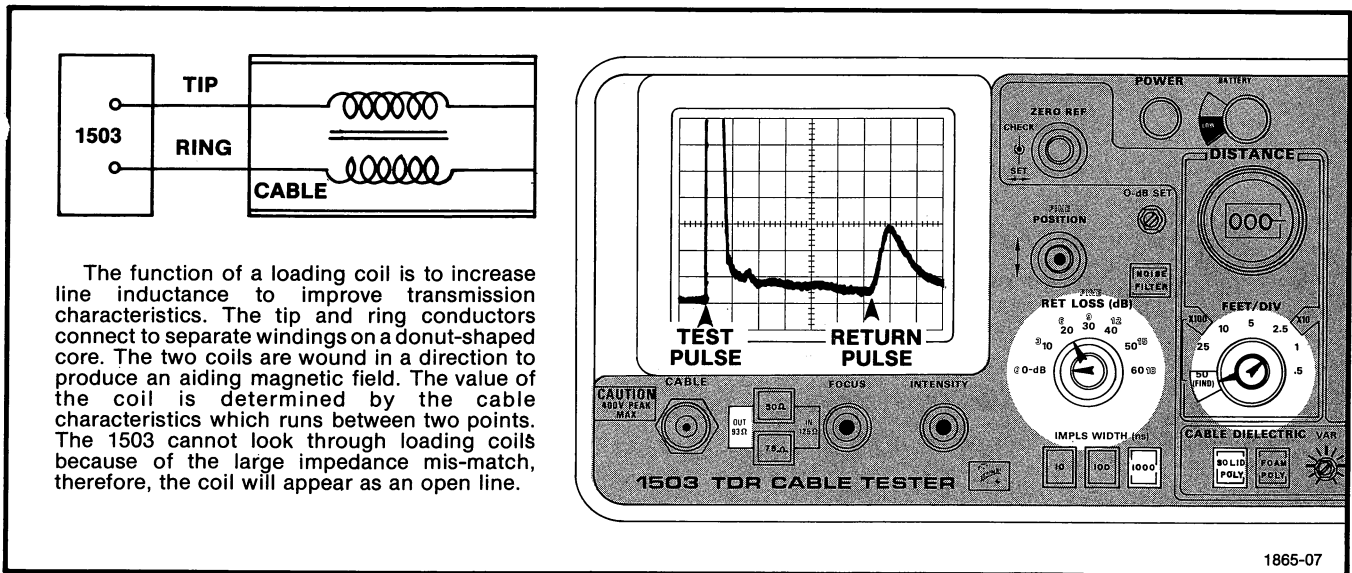

Fig. 2-8. Loading Coil.

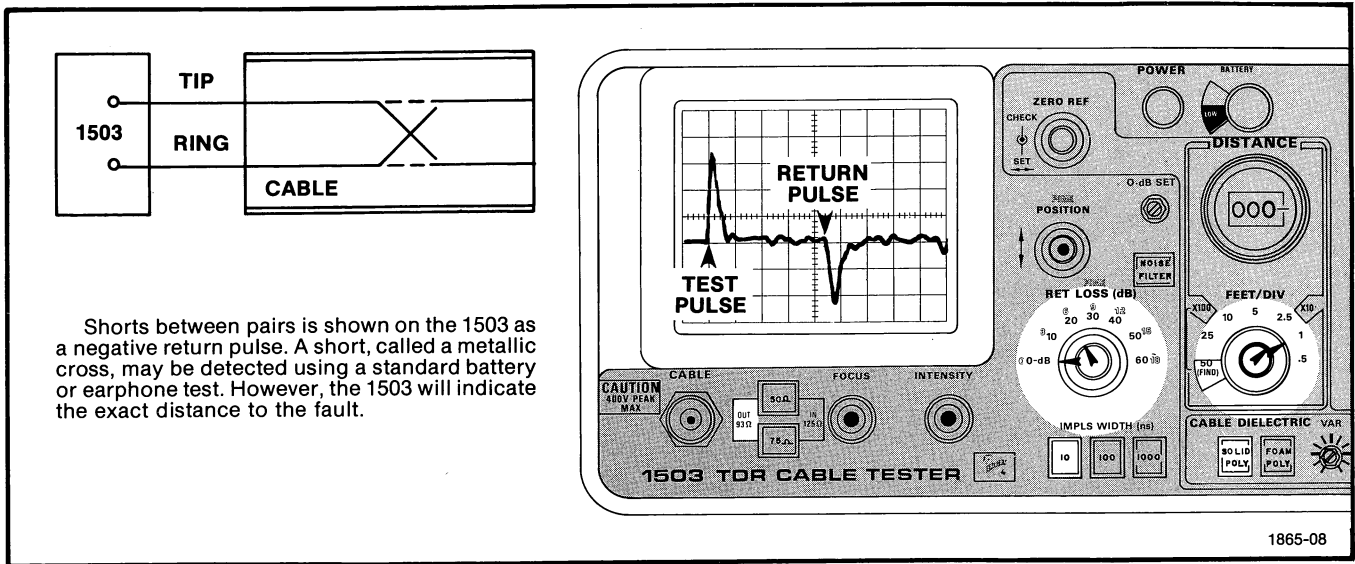

Fig. 2-9. Shorted Tip and Ring.

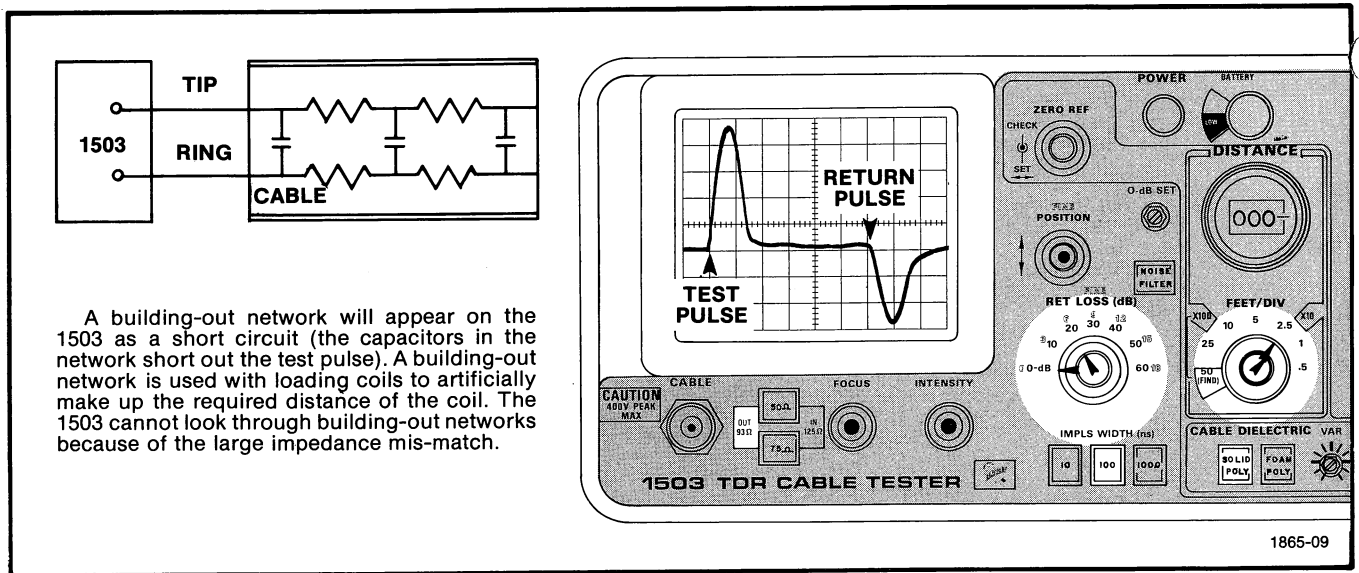

Fig. 2-10. Building-out network.

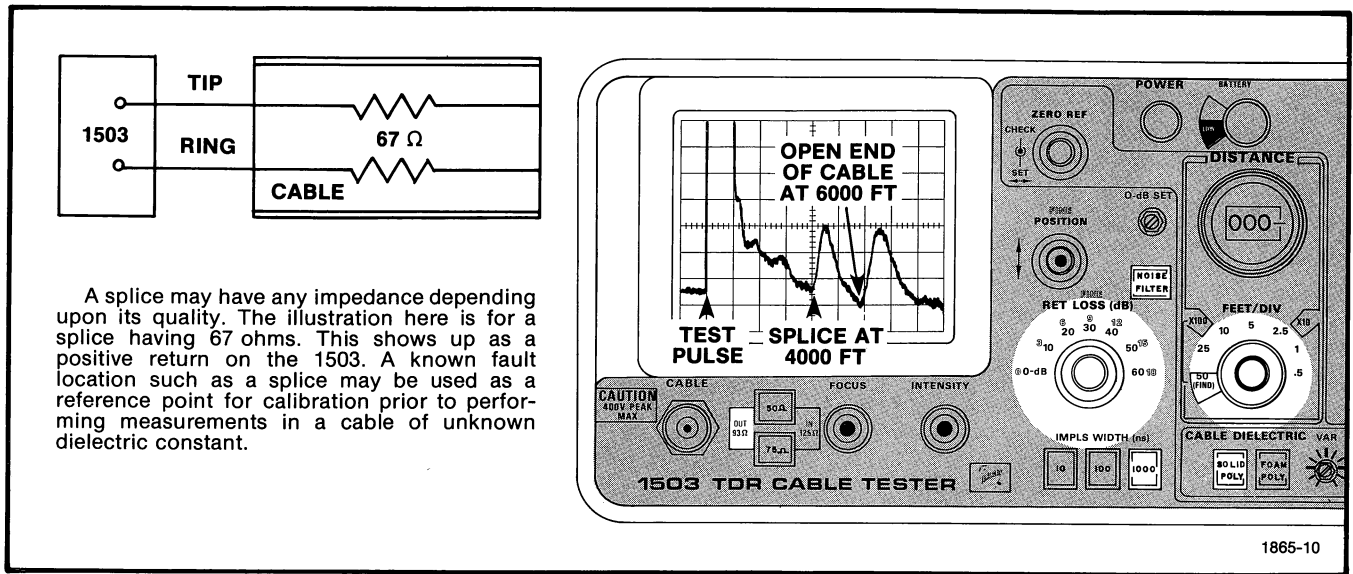
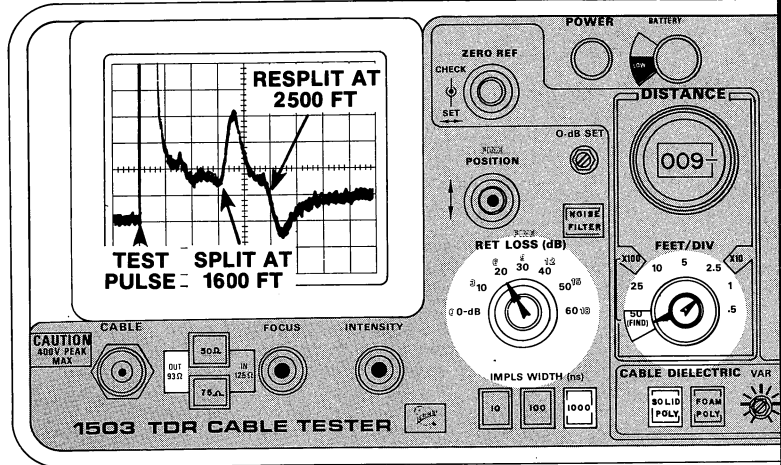
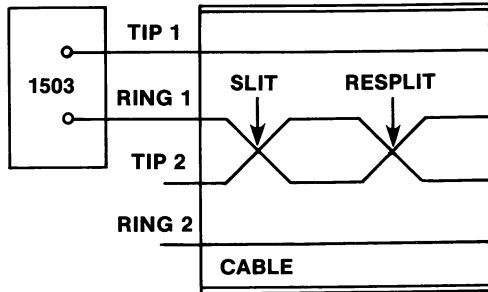
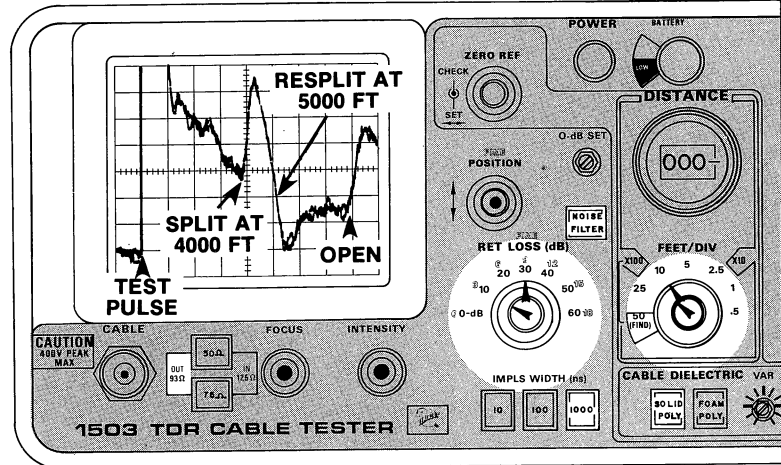

Fig. 2-11. 67-ohm splice at 4000 feet.



A split occurs at a splice when the tip or ring of one cable is accidentally spliced to the tip or ring of another cable pair. The 1503 crt will show a discontinuity similar to that of a splice at the point where the conductors are separated. A decrease in capacitance will be indicated by a positive return pulse. If a re-split (restoration to normal condition) occurs in a subsequent splice, the return pulse will appear with the opposite polarity of that shown for the split.



1865-11

Fig. 2-12. Split and re-split pair.

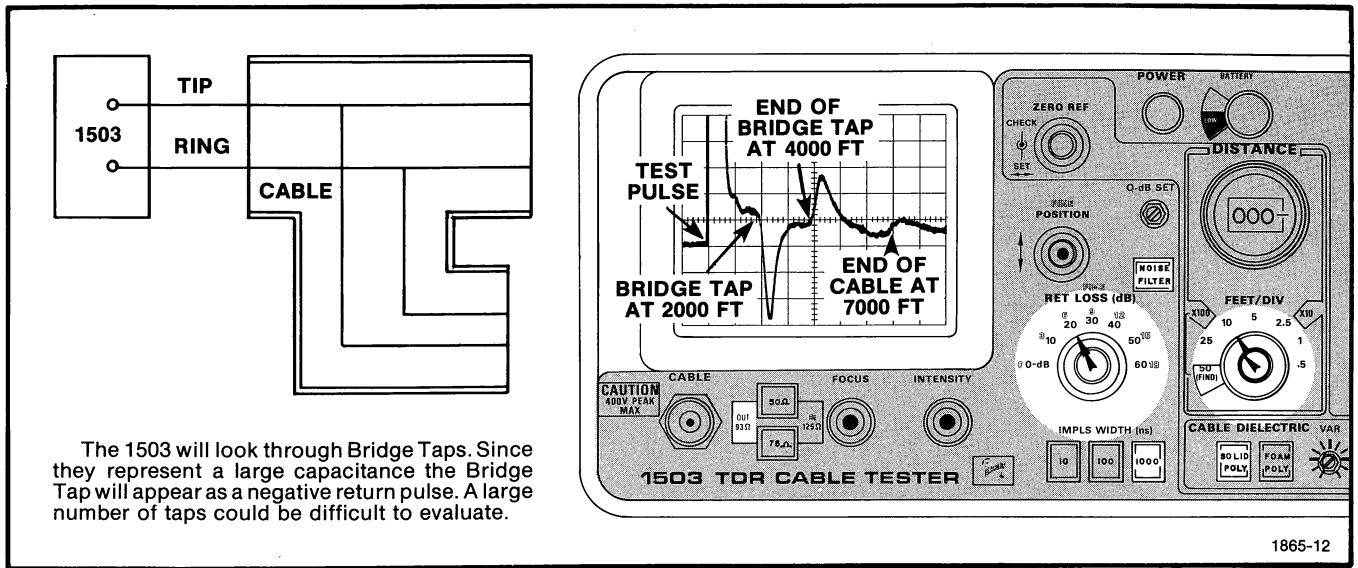

Fig. 2-13. Bridge tap at 4000 feet.

1
2
3
4
5
6
7
8
9
10
11
12
13
14
15
16
17
18
19
20
21
22
23
24
25
26
27
28
29
30
31
32
33
34
35
36
37
38
39
40
41
42
43
44
45
46
47
48
49
50
51
52
53
54
55
56
57
58
59
60
61
62
63
64
65
66
67
68
69
70
71
72
73
74
75
76
77
78
79
80
81
82
83
84
85
86
87
88
89
90
91
92
93
94
95
96
97
98
99
100

THEORY OF OPERATION

This section describes the circuits of the 1503 using a combination of block and circuit diagrams on pull-outs at the back of this manual. The components being described can be found in the circuit diagrams. A cross reference table for each schematic is located on the fold-out page with the schematic.

Circuit Operation

The 1503 uses pulse techniques to check cable conditions. The Pulser circuits transmit the pulses down the cable under test. The Sampler circuits sample the reflections and provide the vertical signal for display on the crt.

Block Diagrams

There are two block diagrams that show the overall functions of the 1503; Fig. 3-1, a simplified version, and the main block diagram located on a pull-out page.

Sequential equivalent-time sampling is used to develop a display. Two ramps are generated, a fast ramp and a slow ramp. The fast ramp is compared to the slow ramp or a fixed reference to generate trigger pulses for the Sampler and the Pulser Generator respectively. These comparisons are made by the Pulser and Sampler Comparators.

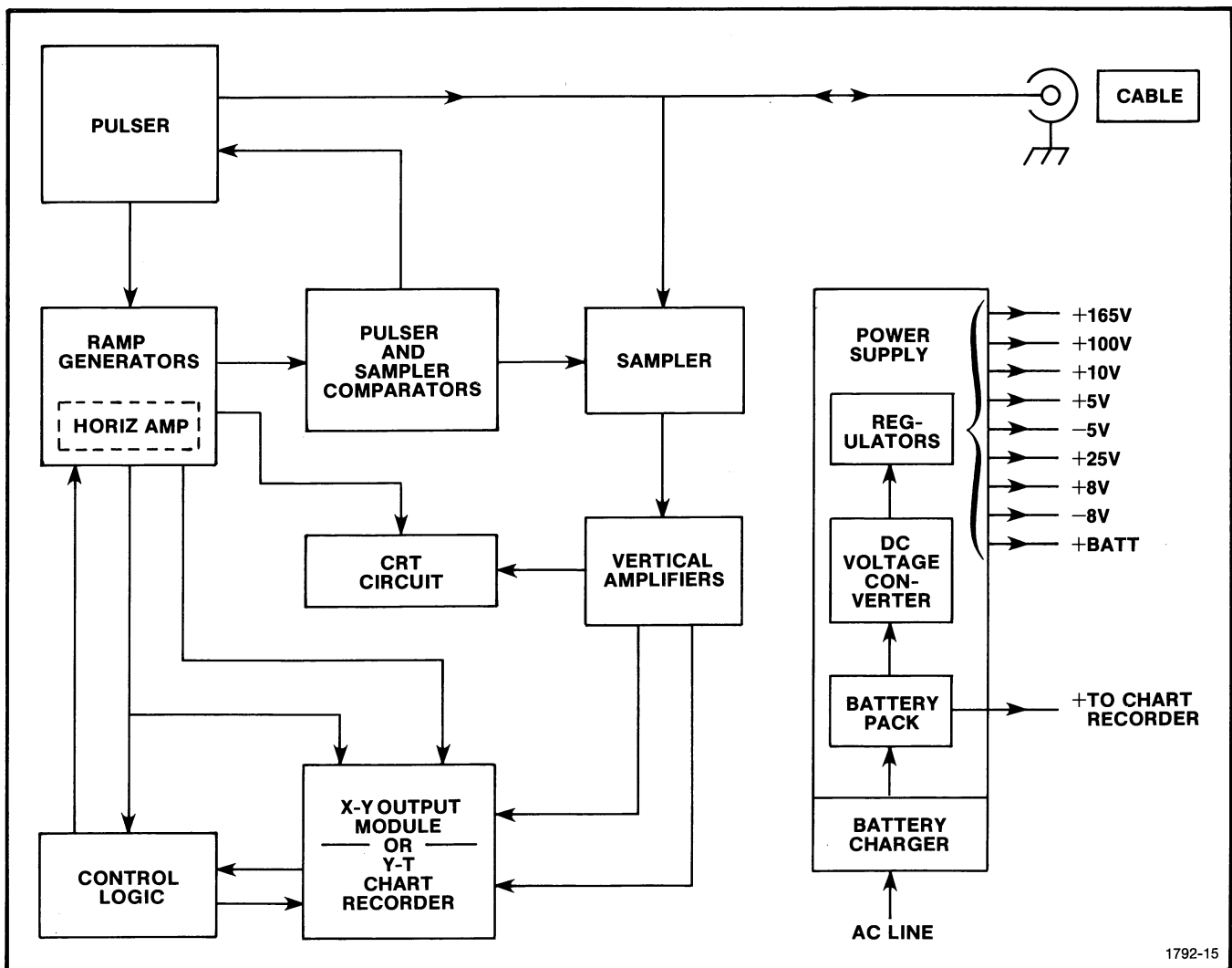

Fig. 3-1. Simplified Block diagram.

A short time after the Pulser Generator transmits the test pulse into the cable under test, depending on the amplitude of the slow and fast ramps, a sampling trigger from the Sampler Comparator causes the Sampler to sample-and-hold the voltage level appearing at the input connector at that time. This voltage sample is amplified and sent to the crt Vertical amplifiers.

The Slow Ramp Generator provides the horizontal sweep for the crt and, combined with the vertical sample, provides a display of the sampled value. Sampling triggers taken later during the next fast ramp time, cause an additional sample to be displayed next to the first one, until a line of dots is formed across the crt, (Fig. 3-2).

The amplified vertical sample and slow ramp signals are also sent to X-Y Interface connectors. These signals, along with a pen lift control signal, provide the information for driving external X-Y recorders.

If the TEKTRONIX Y-T Chart Recorder is used, the amplified vertical signals from the Sampler are applied to the writing stylus drive circuits. The speed of the chart paper is controlled by the holes along the edge of the chart paper passing between a phototransistor and a light emitting diode. These provide digital information to the Control Logic to control the speed of the slow ramp and match the speed of the chart paper. Thus, the trace and grid on the chart recording matches the trace and graticule displayed on the crt.

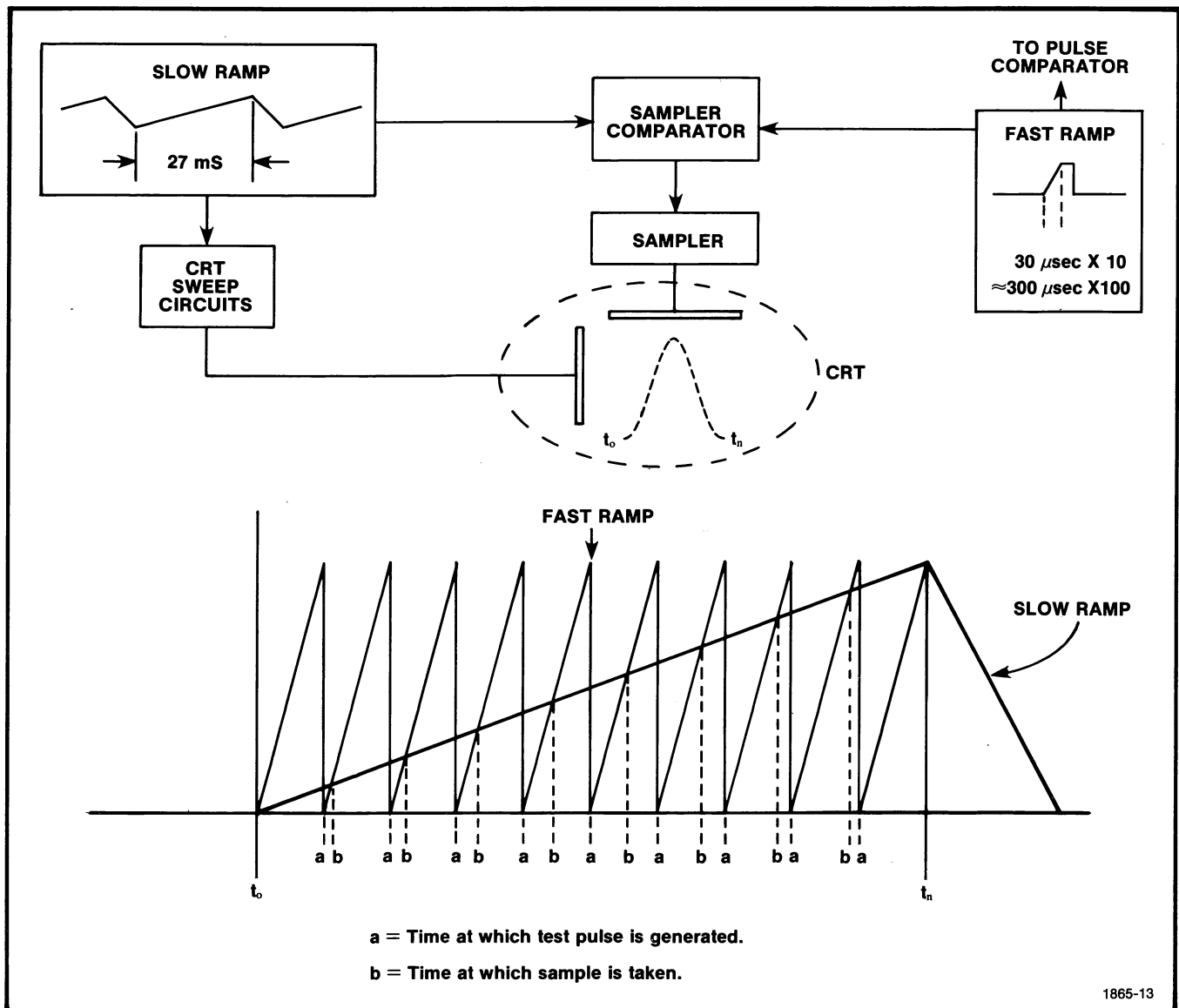

Fig. 3-2. Sampling diagram.

When the slow horizontal scan of the crt has been completed, the vertical input is automatically disconnected and the slow ramp is released to scan at its own speed. The chart paper continues to run until the entire recorded data is outside the chart recorder.

DETAILED CIRCUIT DESCRIPTION

Time Base Generator (Diagram 1)

The Time Base Generator circuits consist of an Inverter/Attenuator, Fast Ramp Generator, and the Timing and Control Logic.

Inverter/Attenuator. The slow ramp signal, is a free running saw tooth generated on the vertical amp/slow ramp board, and entering diagram 1A at P24 in the upper left corner. This signal also goes out to the output amplifier and is the horizontal sweep for the crt. The slow ramp is attenuated by selecting the gain of U1219B with S1215F to provide a calibrated feet per division display on the crt in seven steps: .5, 1, 2.5, 5, 10, 25, and 50 FEET/DIV. This attenuated signal is applied to the inverting input of U1219A through R1216 (FT/DIV CAL). The gain of U1219A as related to the slow ramp is varied by R1216 to provide FT/DIV scale calibration.

The output of U1219A, TP1312, contains a dc level which is obtained from the combined settings of the DISTANCE dial and the ZERO REF SET. The output from the DISTANCE dial also goes to S0151 ZERO REF CHECK. This switch will ground the DISTANCE dial output when pressed and provide a zero reference for checking the setting of the ZERO REF SET potentiometer.

The signal at TP1312 (ORANGE) is a variable amplitude slow ramp whose dc offset is variable by ZERO REF SET and the DISTANCE dial. This signal is applied to the sampler comparator on diagram 1B.

Fast Ramp Generator. The fast ramp generator is basically a constant current integrator consisting of Q1235 and charging capacitors C1238 and C1227. The current for Q1235 is determined by R1137 and R1127. The voltage across these resistors is the 10 volt supply and the base voltage of Q1235 plus the drop across the base-emitter junction of Q1235. The base voltage of Q1235 is the base voltage of Q1142 minus the voltage of the base-emitter junction of Q1142. Thus the two base-emitter voltages of Q1142 and Q1235 cancel each other and compensate for temperature caused changes in base-emitter voltage.

The current through Q1235 will flow when its base is pulled toward ground. When Q1246 is turned off R1135

will pull the base of Q1235 towards +10 V and thus no voltage will exist across R1137 or R1127 and no current will be drawn, conserving battery power between samples.

When Q1247 is turned on, Q1236 will be turned off and Q1235 will be turned on. The current will flow charging C1238 and C1227. The voltage across C1238 will increase linearly with the current. The linear fast ramp is applied to the base of Q1247, which provides a power gain of the fast ramp signal (−2 V to +3.5 V ramp) to drive the comparators, see diagram 1B. It also sends a voltage back to Q1142, through C1243 to compensate for the base current of Q1247.

The resistors R1356, R1357, R1355, and R1353 form voltage dividers whose outputs are selected by S1156 and S1252 (CABLE DIELECTRIC) to set the slope of the fast ramp, keeping ZERO REF SET and DISTANCE calibrated and setting the calibration for FOAM, POLY or Variable cable dielectrics.

Timing and Control Logic

Timing and control of the 1503 Pulser and Sampler circuits begins with the clock signal at U1667C pin 10. The clock runs at a pulse repetition rate of 180 ms, see Fig. 3-3. The clock can be turned off and an external calibration signal inserted at the connector indicated by EXT CAL on the main board.

Fast Ramp Timing. The clock signal is differentiated by C1762 and R1761 and clamped to −5 V by CR1563. The differentiated signal at pin 6 of both U1663 and U1667 will be a positive-going spike occurring at the rising edge of the clock signal. This spike sets the R-S flip-flop so that the output at pin 4 of U1663 goes low. This negative transition is coupled to the delay circuit Q1565 through C1563, turning Q1565 off during the time that C1563 is charging. This holds pin 13 of U1663D high forcing its output at pin 11 to remain low even though pin 12 is low. When C1563 has charged to the point where Q1565 turns back on, the level at pin 13 of U1663D drops to about −4 Volts. The output at pin 11 of U1663D then goes high about 20 ms after the first rising transition of the clock signal.

The output signal from U1663 is coupled to the gate of Q1246, turning it on. It is also coupled through OR gate Q1663C to the base of Q1236, turning it off. This starts the fast ramp by allowing C1238/C1227 to charge.

When the voltage of the rising Fast Ramp at the junction of R1676 and R1663 crosses the reset threshold of U1663A pin 1, the R-S flip-flop will reset, so that its output pin 4 goes high. This high is coupled through U1663D, to the gate of Q1246 and through U1663C to the base of Q1236.

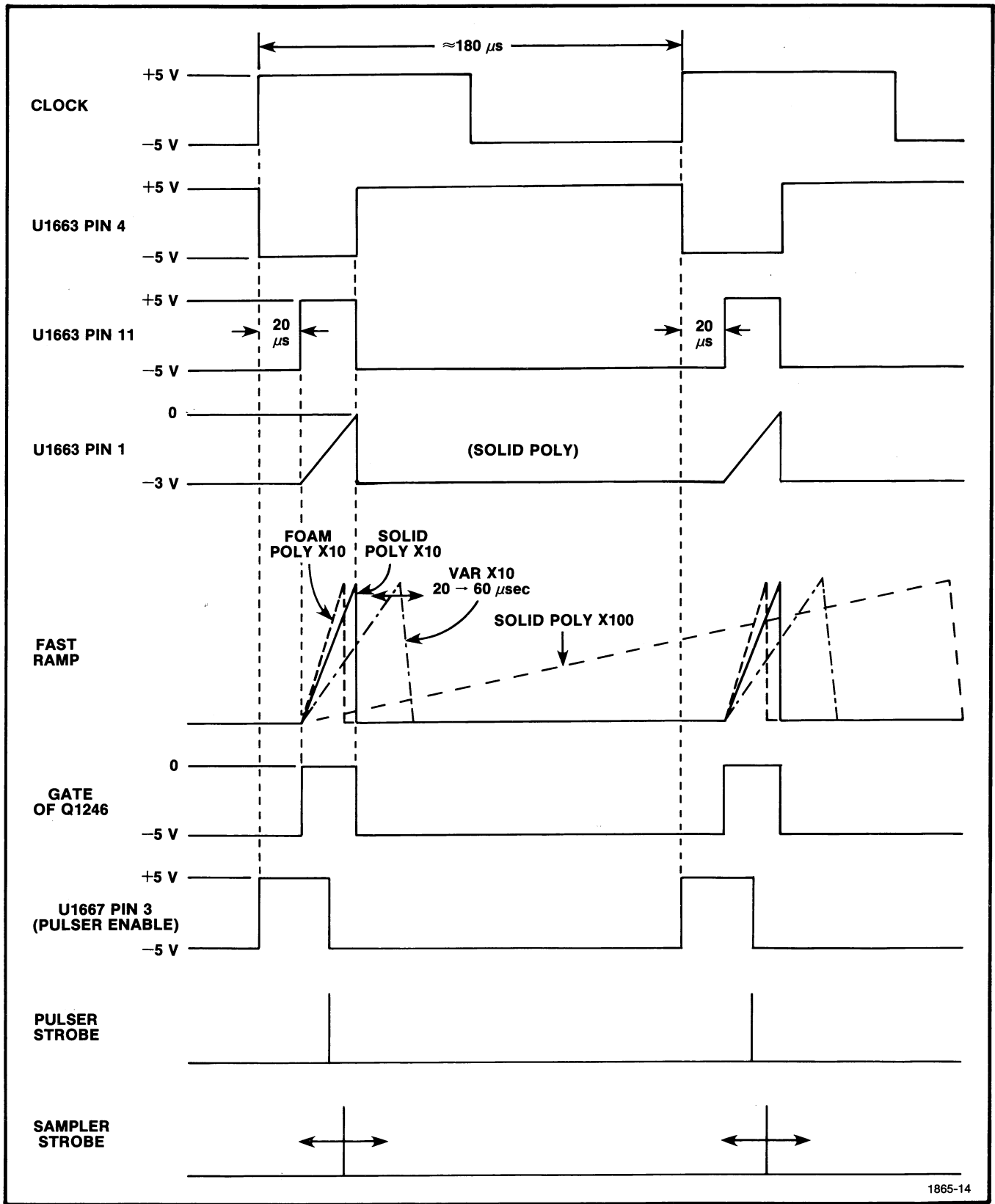

1865-14

Fig. 3-3. Timing diagram.

Q1246 turns off, stopping the fast ramp rise. Q1236 turns on, discharging C1238/C1227. The fast ramp then returns to the level set by Q1332. The next rising transition of the clock signal begins the cycle over again. Rising transitions of the clock signal have no effect during the time of the fast ramp.

The time that C1238/C1277 take to charge determines the length of the fast ramp, see Fig. 3-3. This time is changed by the multiplier switch S1215R and the CABLE DIELECTRIC pushbuttons S1156 and S1252.

Pulser Enable. R-S flip-flop comprised of U1667A and U1667B is used to enable the power to the pulse generator through Q1657 (Diagram 2). It is also used to reset the Pulser strobe generator, Q1556 and Q1551. Pulser power is enabled 20 ms before the fast ramp starts to ensure that the pulser circuits are stable. The Pulser strobe from CR1654 resets R-S flip-flop U1667A and U1667B. This is necessary to save battery power.

Pulser/Sampler (Diagram 1)

The circuits contained on the Pulser/Sampler portion of the main board consist of a Pulser and a Sampler comparator and the Pulser Generator and Sampling circuits.

Both comparators are identical, except the Pulser Comparator is referenced to a dc level and the Sampler Comparator is referenced to the slow ramp signal. They are both essentially current comparators. In the Pulser Comparator the voltage at the emitter of Q1559 is compared to the voltage at the cathode of CR1755. The current that flows through Q1559 is the difference between those two voltages divided by the value of R1655 and R1755. CR1558 is a 1 milliamp tunnel diode and together with Q1558 forms a fast switch. When the current through Q1559 reaches 1 milliamp CR1558 will fire. The switch will change state and the output at the collector of Q1558 will change from -5 V to $+5$ V. The transition is about 30 ns. This causes the generation of one test pulse. The switch will remain in this state until the current through tunnel diode (CR1558) has dropped below its valley point. This occurs when the fast ramp is reset.

The Sampler Comparator works the same, except the time at which the comparator fires is delayed due to its being referenced to a slowly increasing voltage (the slow ramp). Thus the sampling point is slewed by the level of the slow ramp (see Fig. 3-2).

Pulse Generator

The Pulse generator consists of a current source Q1435 and various inductors and capacitors selected by IM-PULSE WIDTH (S1343). The current source is turned on causing energy to be stored in the selected inductor. The pulser strobe causes Q1435 to turn off which results in an induced pulse whose frequency is determined by the selected inductor/capacitor parallel resonant circuits. The voltage at the collector of Q1435 will swing negative once but will be clamped to zero as it attempts to go positive. The strobe that turns off Q1435 also resets flip-flop U1667A and U1667B and turns off the current source.

Q1556 and Q1551 comprise a pseudo SCR circuit which is triggered by the pulse from the comparator circuit Q1558 and CR1556. When the SCR fires it turns Q1435 off in approximately 2 ns. The trigger from the comparator is also sent to U1667 pin 2, an RS flip-flop, through CR1654 resetting the flip-flop which turns off Q1657, thus keeping the current source Q1435 off.

When Q1435 is turned off the collector voltage will tend to ring due to the energy in the inductor/capacitor circuit and swing negative and positive with respect to ground. Clamping diode CR1434 and Q1436 prevent any positive excursion of the voltage. Due to the clamping action all energy from the inductor/capacitor circuit is dissipated and only one negative-going half-sine pulse is generated.

This pulse is applied through C1447 to the output stage Q1637. The output stage is basically a class B common-emitter amplifier which is biased to about $+24$ V. The emitter goes to the $+25$ V supply through a network of resistors. These resistors provide the required gain to output the pulse voltage (0-5 V) into the selected characteristic impedance. The output of the Pulse amplifier Q1637 is sent to the CABLE connector through dc blocking capacitor C1715.

CR1639, R1646, and C1647 form a clamping circuit to prevent high positive transient voltages from damaging Q1637 and the sampling circuits. Voltages above $+25$ V will forward bias CR1639 causing it to conduct and charge C1647. When the voltage is removed, the excess voltage drains through the $+25$ V supply; returning the charge on C1647 to its quiescent level of $+25$ V.

The clock signal from U1667 pin 10 is rectified by CR1647 and CR1648 and regulated by VR1649 to -9 V across C1648. Any fast-transient negative-going voltages on the CABLE will be clamped to about -9 V.

Slow transient positive or negative voltages, less than 400 V and less than 400 Hz, will be blocked by the reactance of C1715 and the selected output resistance.

Sampler

The sampler circuits receive the test pulse and the reflected pulse from the Pulse Generator and the CABLE connector via a coaxial cable. The cable has a ferrite bead isolator. The R1791, R1733, and R1734 provide impedance matching for the cable. Capacitors C1741 and C1742 compensate for a dc component of the pulse train.

First Sampling Gate. During the period in which the gate diodes are forward biased by the strobe pulse capacitors C1697 and C1793 appear in parallel and are charged to a portion of the input signal level at that instant. The amplifier U1795 is too slow to respond. After several hundred nanoseconds the amplifier realizes that its input/output levels are not in the correct proportion and the output begins to move to correct the situation causing charge redistribution between C1793 and C1697. Closer look at the amplifier shows that is a non-inverting amplifier with positive feedback by means of C1697. The gain of the feedback loop is varied from 1 to .62 by R1693 in conjunction with R1692 and the forward gain is 1.62, set by the same resistors for an equivalent loop gain variation of 1 to 1.62. The final state of charge on each of the capacitors C1793 and C1697 is determined by their values and the loop gain. The output voltage thus may be varied by R1693 to produce an output equal to 1.62 times the true input before sampling. This results in an equivalent sampling efficiency of 100%.

First Blow-by Compensation. Blow-by results from energy feeding through the junction capacitance of the sampling diodes even though they are turned off. The first blow-by compensation is accomplished by R1796 and R1793. These resistors feed a portion of the input signal into the inverting input of operational amplifier U1795. This cancels the blow-by voltage at the output of U1795. The amount of compensation depends upon the setting of R1796.

Second Sampling Gate. Q1594 and U1503 comprise the second sampling gate. Second sampling is required to reduce the effect of unbalanced leakage current in the first sampling gate diodes. The output of the sampler comparator Q1578 is used to turn the gate on for about 8 ms, allowing C1593, the second memory capacitor, to charge to the level of the sampled signal. U1503 amplifies the level stored on C1593 and provides the discharge path for C1593 between charge times. Fig. 3-4 illustrates the timing of the second sampling circuits.

Second Blow-by Compensation. Blow-by resulting from gate-drive energy feeding through the gate to source capacitance of the second sampling gate is compensated for by feeding a portion of the drive signal into the inverting input of U1503. This portion is obtained through R1597, C1595, and R1406. The amount of the first sampled signal sent to U1503 is determined by the setting of R1406.

Log Amplifier. Amplifier U1695B in conjunction with R1603 and R2126 is used to amplify the sampled signal logarithmically from 0 to 18 dB providing the FINE dB loss control.

Slow Ramp Generator (Diagram 3)

Integrator. An inverting amplifier circuit with a FET input is used as an integrator. Integrator capacitor C2356 is connected between the collector of Q2345 and the inverting input (gate of Q2246A). A negative current applied to the inverting input through R2353 results in a linear rising voltage at the output (see the waveform shown in Fig. 3-5). This output voltage will continue to rise until it reaches an internal comparison level of 4.1 V. The bi-level comparator output then switches to a higher output level to close the FET switch, Q2257. It also changes its comparison level to -0.1 V. This allows a positive current to be applied to the input of the integrator through R2251. The positive current is ≈ 13 times larger than the negative current and causes the output voltage of the integrator to decrease linearly. After a short period of time, the integrator output voltage approaches this comparison voltage of -0.1 V and causes the positive current into the integrator to be turned off. At this time the comparator level is switched back to the 4.1 V level and the cycle starts over.

The rise and fall time of the slow ramp can be varied by changing the integrating capacitance values. In the normal 40 Hz scan a value of $0.0013 \mu\text{F}$ is used. When NOISE FILTER switch S2254 is activated, the scan frequency is reduced by approximately 7 times by paralleling a capacitance value of $0.01 \mu\text{F}$ to the original $0.0013 \mu\text{F}$. For recording (X-Y or chart) purposes, a value of $1 \mu\text{F}$ is used. (Q2248 acts as a FET switch and is controlled by the Record Logic.)

Bi-Level Comparator. During the positive going sequence of the Slow Ramp Generator, Q2161 is saturated and Q2166 is off. The emitter voltage of Q2161 and Q2166 is 4.1 V. This voltage is controlled by a resistor divider, R2267 and R2158. The collector (output of the comparator) of Q2166 is at a -5 V level because the transistor is not conducting. The anode of CR2159 has to rise to 4.1 V in order to turn off Q2161.

When Q2161 turns off, its collector level will decrease, which causes Q2166 to be turned on and saturated. The emitter voltage output switches to -0.1 V. Q2161 remains off until the anode voltage of CR2159 goes to -0.1 V, which restarts the cycle.

The comparator can be forced into the retrace cycle by a $+5$ V signal at the anode of CR2262.

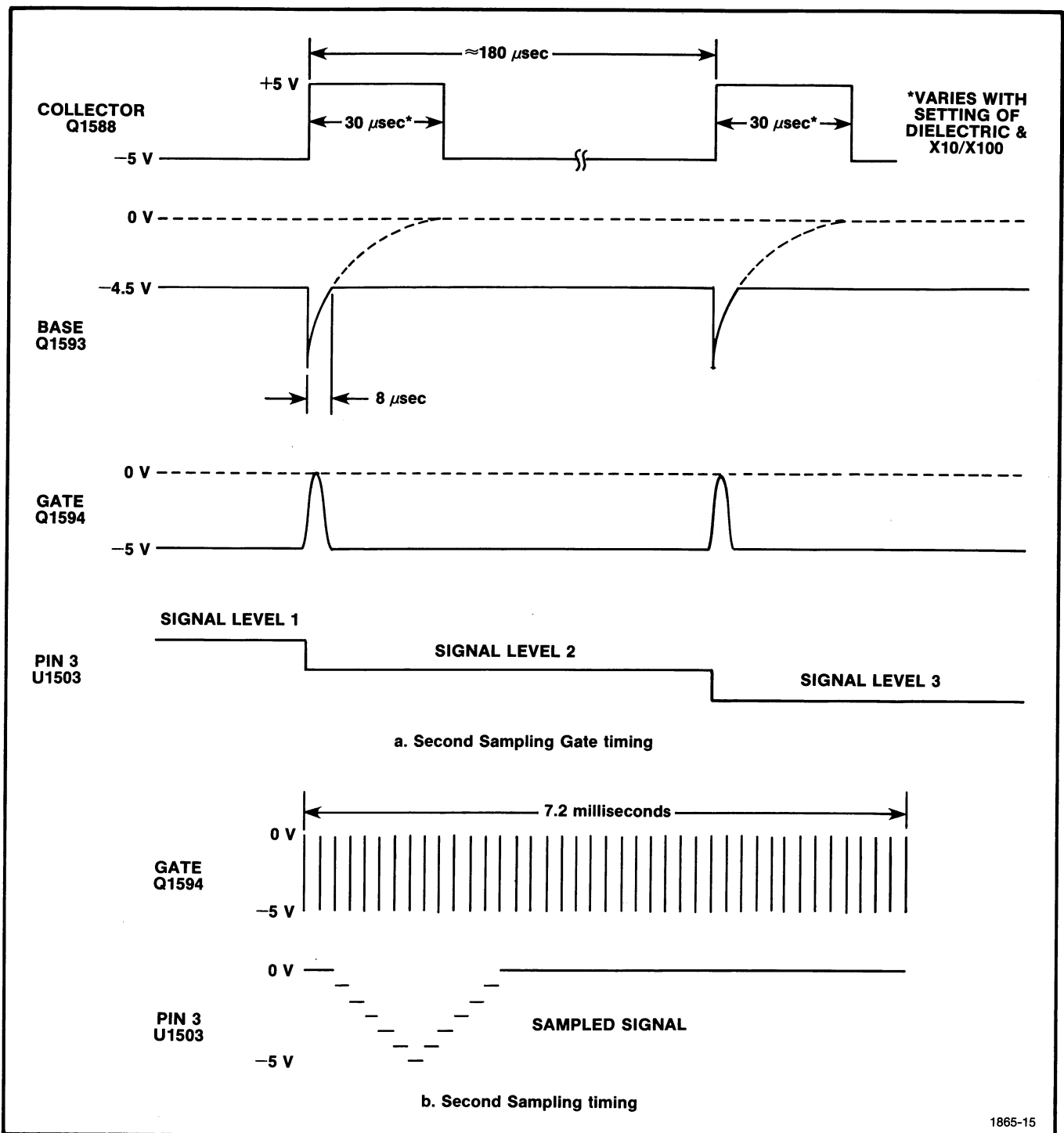

Fig. 3-4. Sampling Circuit timing.

Retrace Signal Amplifier. The retrace signal amplifier uses an input FET (Q2258) to drive amplifier Q2259. The output voltage is +5 V during retrace and -5 V during the scan cycle. The output is used for Chart Recorder Logic and Record Logic.

Current Sources. The positive and negative currents for the retrace sweep are generated by applying +5 V and -5 V to the high value resistors R2251 and R2353 respectively.

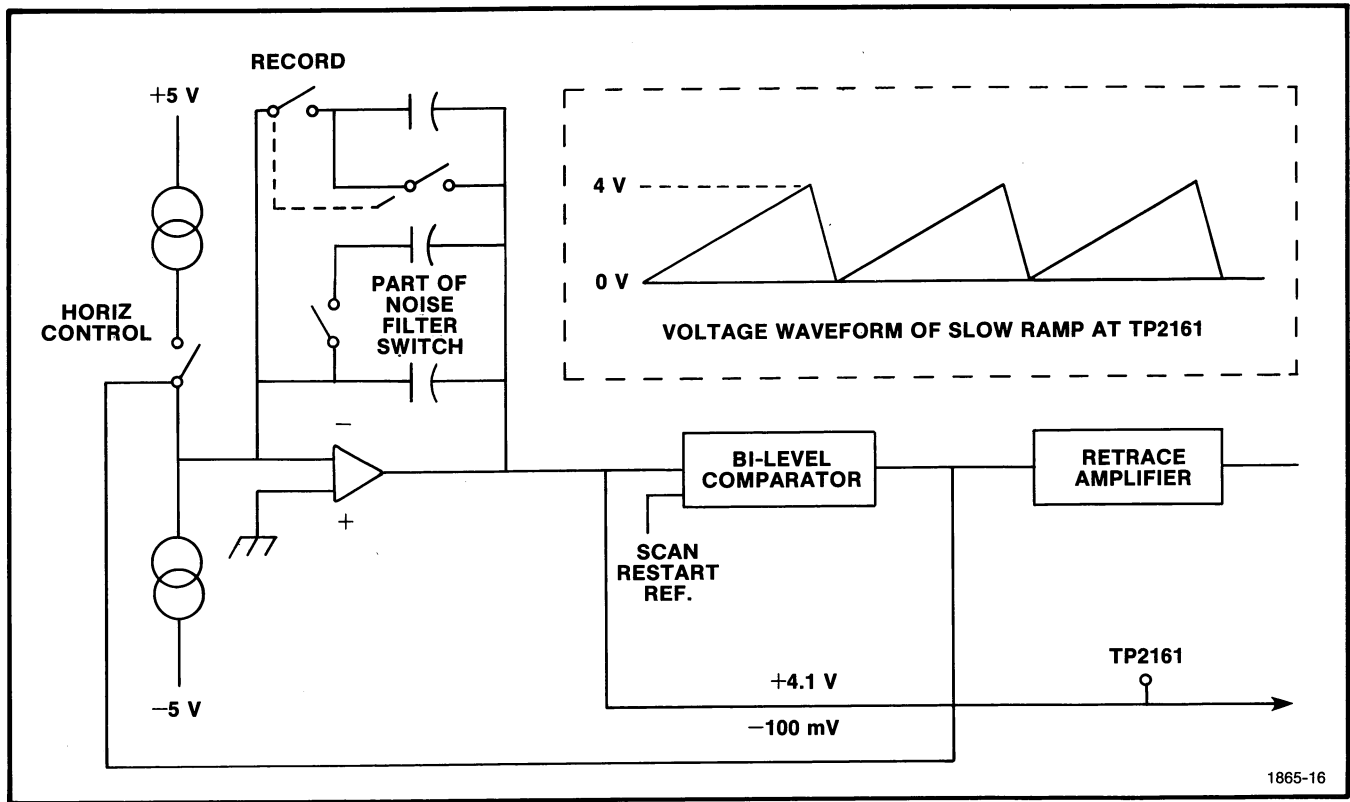

Fig. 3-5. Functional block diagram of the Slow Ramp Generator.

X-Y Recorder Logic

The X-Y Recorder Logic consists of multivibrator U2332B and U2332D; gates U2332A and U2332C (and multiplex switches U3223A and U3223B on diagram 4).

During the normal mode of 1503 operation, the output of the multivibrator (PEN LIFT: TP2157, yellow) is low and Q2248 is not conducting. Pin 10 of U2332C is low and Q2249 is not conducting. By pressing RECORD switch S0481B, the RECORD line goes high, the multivibrator changes level, and TP2157 becomes high (+5 V). This turns on Q2248. The output of U2332A (pin 3) goes low, and the output of U2332C (pin 10) goes high. This turns Q2249 on. Q2249 and Q2248 keep C2356 discharged and the output of the Slow Ramp remains at 0 V. By releasing the RECORD switch, the output of U2332C goes low, which turns Q2249 off, but, Q2248 stays on. This starts the Slow Ramp Generator scanning at a much slower rate due to C2352 being added to the circuit. When the scan cycle ends, the output of retrace amplifier Q2259 goes high, causing multivibrator U2332D and B to be reset. This sets the Recorder Logic back to the normal mode of operation.

The components CR2324, R2324, and C2325 are used to ensure that the Recorder Logic is in the normal mode of operation when the power supply switch is turned on.

Horizontal Output Amplifier (Diagram 4)

The Horizontal Output Amplifier consists of Q3221, Q3118, Q3113, and Q3114. This amplifier amplifies the 0-4 V, slow ramp signal into a differential voltage of approximately 150 V as well as shifting the output level to an average voltage of 85 V. The amplifier gain is approximately 37 and is achieved with a differential transistor amplifier, Q3221 and Q3118. The gain is controlled by the ratio of resistance R3122 or R3121, to the parallel values of resistors R3217 plus R3116, and resistors R3216 plus R3212. R3217 is variable to adjust for crt deflection factor tolerances. The differential amplifier uses Q3113 and Q3114 as a current mirror current source. The thermally stable current is set by R3112, R3114, and R3115. R3213 is used for horizontal positioning.

Vertical Amplifier (Diagram 4)

The Vertical Amplifier circuit contains selectable gain amplifier U2136 with positioning control, variable gain amplifier U2143 to calibrate the instrument for different cable impedances, retrace logic, and a vertical output amplifier.

Selectable Gain Amplifier. This circuit consists of operational amplifier U2136, and a bank of resistors for

gain selection. The required resistors are selected by switch S2126 (RET LOSS). The resistors are selected to provide a logarithmically varying gain.

The operational amplifier is connected as a voltage follower. The non-inverting input receives its signal from the log amplifier through R2138 and the positioning signal from amplifier U2131 through R2137. High-frequency noise is filtered by 0.001 μ F capacitor C2137. Additional noise filtering can be obtained by activating the NOISE FILTER switch, S2254, which adds a 0.1 μ F capacitor, C2241, to the circuit and reduces the horizontal sweep rate.

Positioning. Vertical trace positioning is accomplished by offsetting the dc level of the input vertical signal. Operational amplifier U2131 provides the dc offset voltage. U2131 is controlled by R0251A (POSITION) and R0251B (FINE).

Variable Gain Amplifier. The Variable Gain Amplifier consists of U2143 with variable gain provided by R0263. The incoming voltage is attenuated approximately 50% by R2233 and R2144. The output voltage is approximately 200 mV per division. The variable gain control has a range of approximately 5 times and is set by the values of R0263 and R2142. The output goes through the Retrace Logic to the Vertical Output Amplifier.

Retrace Logic. The Retrace Logic consists of Gate U3123C, inverter Q3137, controllable oscillator U3123A and U3123D, and analog switches U3223C and U3223D.

The only time the vertical signal is applied to the vertical output amplifier is during the forward scanning cycle. During the retrace cycle, an offset voltage is applied to the vertical output amplifier.

During the slow ramp's forward scan cycle, the retrace signal is negative, as is pin 2 of U3123A. This causes the output of U3123D to be low. Pin 6 of U3223C is also high, while pin 12 of U3223D is low, and the vertical signal passes through the analog gate to the output amplifier.

During the retrace cycle, the output of U3123D is low and pin 6 of U3223C is low while pin 12 of U3223D is high. This allows the output of U3123D to be passed to the vertical output amplifier. This causes the beam to be deflected below the crt viewing area.

Vertical Output Amplifier. The Vertical Output amplifier consists of Q3236, Q3232, Q3139, and Q3235. The mode of operation is identical to that of the Horizontal Output

Amplifier. In the Vertical Output Amplifier the amplifier gain is approximately 80. Capacitor C3233 is added to increase high frequency response.

Display Circuits

The display circuit contains the High Voltage Supply, which provides the voltage for the FOCUS control, INTENSITY control, and the cathode of the crt and the crt biasing network. The crt, which provides a display of the conditions of the cable being checked, is also shown in the circuit.

High Voltage. The high voltage circuit consists of: an oscillator, formed by transistors Q4149 and Q4145; transformer T4241; a high voltage multiplier circuit consisting of CR4323, CR4313, CR4311, and CR4211, and a resistor divider string consisting of R4114, R4126, R4222, R4129, R4221, INTENSITY control R0442, and FOCUS control R0432.

The self-starting oscillator is formed by R4148 and R4145 and transformer T4241. The transformer has a separate feedback winding (pins 9, 10, 11) which ac couples the voltage to the bases of the transistors Q4149 and Q4145. R4146 and R4141, along with the 0.001 μ F capacitors C4135 or C4134, establish a time-constant sufficient to prevent saturation and establish the oscillator frequency.

Winding 7-8 of the transformer provides a 0.6-V rms signal for the crt filament. This winding is high voltage insulated. Winding 4-6 provides a 500-V square wave that is used to generate the high voltage. The high voltage multiplier circuit converts the 500 V to 2000 V. The resistor divider string is connected between the 2000 V and the 1000 V taps of the multiplier circuit. This provides the voltages for correct biasing of the crt. The FOCUS and INTENSITY controls are part of this divider string. A 150 V zener diode, VR4117, is used to stabilize the cathode to grid potential.

Power Supply

The Power Supply consists of a line selector, transformer T0389, a battery charger network, battery pack BT0369, and the dc to dc voltage converters. The battery charger network contains SCR switch Q6157, SCR triggering circuit Q6143, Q6244, and Q6241, operational amplifier U6138, and current reference resistor R6131.

The dc voltage converters contains an Anti-Deep-Discharge circuit (Q6548, Q6549, and Q6547); a primary regulator (Q6552, Q6557, and VR6459); a duty-cycle controlled oscillator (Q6458, Q6445, C6551, R6545); a fly-back switch (Q6435 and Q6349); and fly-back transformer

Theory of Operation—1503

T6535. The secondary output windings of T6535 provide the +165 V, +100 V, +25 V, +10 V, +8 V, -8 V, +5 V, and -5 V supplies. The +10 V, +5 V, and -5 V circuits have secondary regulation circuitry. See Fig. 3-6 for a simplified block diagram of the power supply.

Battery Charger. Line transformer T0389 in conjunction with full wave rectifier CR6157 provides battery charge current. The battery charge current is regulated for an average current of 150 mA (independent of battery load).

A reference voltage of approximately 50 mV is created across reference resistor R6132. This voltage is created by R6135 and VR6134. The battery load and charge current are always fed through R6131 and the charger will try to maintain an average current of 150 mA into the battery. This is done by comparing the voltages across two reference resistors (R6132 and R6131) using operational amplifier U6138. Depending upon the battery charge current, the output of the operational amplifier will provide more or less current into the current source input Q6244. With every new cycle, a current (of the same magnitude as the input current) will be released by Q6241 to charge capacitor C6147. This current will be increased or decreased to maintain an average of +50 mV across R6131. The voltage across C6147 builds up every cycle until it reaches the firing threshold level of the programmable unijunction transistor (PUT) Q6143. At this moment, a triggered pulse occurs at the cathode of the PUT, which in turn fires SCR Q6157. When this occurs, a portion

of the full-wave rectifier output provides a charge current for the battery during the remainder of the cycle. During this same period, C6147 gets discharged through the anode of the PUT. The point at which the triggering occurs is determined by how fast C6147 becomes charged to the reference voltage of about 4.5 V and the charging speed is determined by the average current to the battery.

Because the charge current and load currents are in the form of pulses, averaging (integration) is performed at the output of operational amplifier U6138 by a 15 μ F capacitor C6233. Zener diode VR6235 provides level shifting. Battery pack BT0369 consists of nine nickel-cadmium C cells. CR6234 prevents reverse biasing of C6233.

NOTE

For proper operation, the battery pack must be in place at all times during operation of the instrument.

DC Voltage Converter. The controllable oscillator is an astable multivibrator (Q6458 and Q6445). The collector of Q6445 is high for 8 μ s and low during the remainder of the period. The 8 μ s period is set by C6551 and R6545 in parallel with R6449 and R6457. The low voltage duration at the output is controlled by the primary regulation voltage of Q6552, R6454, and C6451. Diode CR6452, R6451, and R6453 protect against base-emitter reverse breakdown voltage.

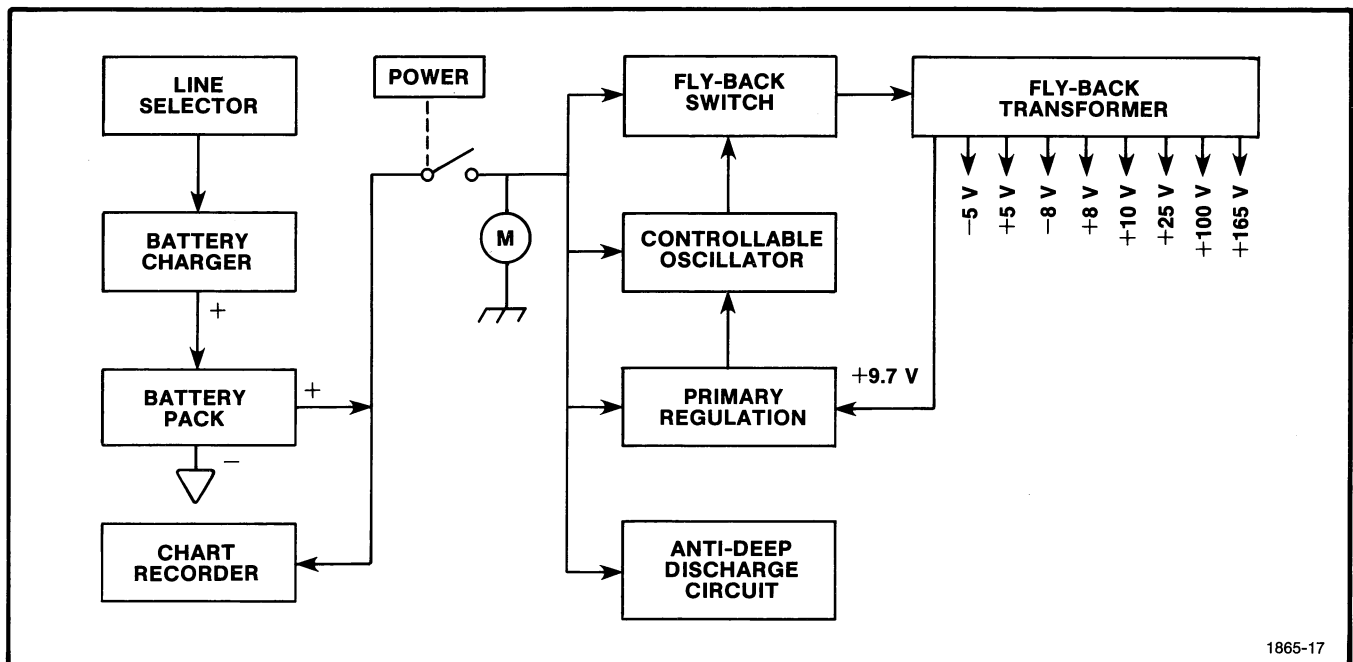

Fig. 3-6. Block diagram of 1503 Power Supply.

The output of the astable multivibrator is connected to the fly-back switching circuitry consisting of Q6349 (a Darlington emitter follower) and Q6435 (a high current switch). Q6435 conducts when the output of the multivibrator is high, so a magnetic field builds up in fly-back transformer T6535 by way of windings 5-6 during the 8 μ s period. When Q6435 turns off, the field collapses and the stored energy is transferred to the secondary windings. Diodes CR6347, CR6441 and CR6442 prevent Q6435 from saturating, causing the switch-off time to be faster. To reduce the base drive energy, a voltage source that is lower than the battery pack is used. This is supplied from terminal 3 of T6535 through diode CR6446.

The +25 V (pre-regulated) supply is used to control the primary regulation. (It is also used for the high voltage circuitry and the pulse generator.) A voltage tap is provided by way of R6358 and Q6357 to create 9.7 V as a reference voltage for the primary regulator network. This voltage is compared against the combined voltage of 9.1 V zener diode VR6459 and the base-emitter junction of Q6557. Depending on the voltage level of the 25 V supply, Q6557 conducts more or less. The amplified collector voltage is fed to astable multivibrator Q6458 and Q6445 by way of emitter-follower Q6552. This controls the duty cycle of the astable multivibrator.

Anti-Deep-Discharge Circuit. The Anti-Deep-Discharge circuit prevents the battery pack from going into deep discharge, which could permanently damage the batteries. Q6549 and Q6547 are connected as an SCR network. When fired, both transistors fully conduct, which forces the collector of Q6557 to ground. This reduces the input voltage to the input of the astable multivibrator, and turns it off, disabling the dc voltage converter.

The SCR network is triggered when Q6548 conducts. This happens when the battery voltage drops below 10 V. The +10 V power supply is used as reference voltage by way of CR6546 and R6539. To reset this SCR network, the battery voltage must be removed by turning off the front panel POWER switch. The batteries must be charged or replaced (unless ac power is to be used) before further operation of the instrument. To allow quick discharge of C6443, when the power switch is off, and reset the SCR latch quickly, R0165 is connected between ground and C6443 by switch S0165.

CAUTION

When the Anti-Deep-Discharge circuit is operating, the voltage circuits are turned off, but there is still a small amount of current drawn from the batteries. This will further discharge the batteries (at a slower rate) if the POWER switch is not turned off.

Voltage Regulators. The +165 V, +100 V, +8 V and -8 V supplies are not individually adjustable. R6358 is used to adjust the +25 V supply to the correct output voltage. The +10 V regulator provides a 10 V reference for the +5 V and -5 V regulators.

The 5.1 V zener diode, VR6417, is used in a bridge configuration to provide a reference voltage for the +10 V supply. R6518, R6513, R6413, and R6514 are part of this bridge network. The bridge outputs are fed into operational amplifier U6515, which drives series regulator Q6427. Zener diode VR6419 is used as a start-up circuit. Capacitor C6416 provides additional power supply filtering.

Q6331 is the series regulator for the +5 V power supply. The +5 V is referenced against the output of the divider, R6225 and R6231, which in turn is driven by the +10 V supply. The output of U6236 drives the series regulator in a voltage follower mode.

The -5 V power supply uses Q6227 as a series regulator. U6222 is used as a controlled current source and the minus voltage connection (-V) is connected to the base of the series regulator. Part of the no-load amplifier current is shunted by R6222 and the load current fluctuations are used to control Q6227. R6223 is a current limiter.

Control Logic (Diagram 5)

The Logic board is used only with the TEKTRONIX Y-T Chart Recorder. This board can be removed without affecting the operation of the 1503. However, if this board is removed, the RECORD switch would have to be connected to the Vertical board by connecting the cable from the RECORD switch to P28 on the Vertical board.

The Logic board consists of pulse shaper, U5166A, U5166B, U5166C, and U5166D; binary counter U5147; a horizontal correction network; Chart Recorder Logic for controlling the paper drive motor; stylus heat; a Chart Recorder power switch; and an anti-bounce record circuit.

Pulse Shaper. The Pulse Shaper is made up of U5166A, U5166B, U5166C and U5166D. When the paper is moving, a square wave signal (CHART SPEED SENS) is generated by the holes in the paper passing between a light-emitting diode and a photo-sensitive transistor. The resultant small pulses are shaped to a clean square wave by a high gain amplifier circuit, U5166B and U5166C. The output signal is capacitor-coupled by C5167 to one-shot multivibrator U5166A and U5166D. This one-shot produces an output signal at TP5145 (violet test point) which is a positive going pulse approximately 10 ms wide. This (clock) pulse

Theory of Operation—1503

is connected to binary counter U5147; and to the end of the paper motion sensor network, R5148.

Counter. The 7-stage binary counter is an integrated circuit U5147. The binary outputs are connected to an R, 2R resistor ladder network, which together with U5117 forms a digital-to-analog converter. Outputs Q1 and Q7 are connected to AND gate U5252B so that it recognizes the count number 65. Q2 clocks multivibrator U5127B at count 2. (The signal from U5127B starts the slow ramp.)

Horizontal Correction Network. The Horizontal Correction network compares the output of the digital-to-analog converter, with the inverted slow ramp signal. U5227 inverts the slow ramp signal.

The digital-to-analog output and inverted slow ramp signal are connected to inverting amplifier U5117, which performs summation and amplification simultaneously. This signal is fed to the Slow Ramp Generator by way of R5118 and will speed up or slow down the Slow Ramp Generator to synchronize it with the paper speed of the Strip Chart Recorder.

Chart Recorder Logic. The logic control signal that is received through pin 2 of P53 is shaped into a narrow impulse (negative going) by U5156B and U5156C. This impulse occurs at the trailing edge of the logic control signal and latches bi-stable multivibrator U5252A and U5252C. Pin 9 of U5252A goes positive, turns on Q5266 which pulls the motor control line to ground, causing the paper drive motor to start rotating. The paper drive motor is turned off at a count of 65 by U5252B. A second signal is capable of turning the motor off. This occurs when the end of the paper is reached and the output from the pulse shaper is stopped. This causes C5249 to discharge and unlatch the multivibrator.

The multivibrator is initially latched when the inverted control signal from pin 4 of U5156B charges C5249. The impulse from pulse shaper U5166A and U5166D keeps C5249 charged. The multivibrator latch (output of pin 10) disables the reset of the counter and turns Q5144 on. This locks out the logic control input line.

Stylus heat control comes from Q5239, which is turned on by flip-flop U5127A. This flip-flop is energized by PEN LIFT signal from the Vertical board. The RETRACE signal

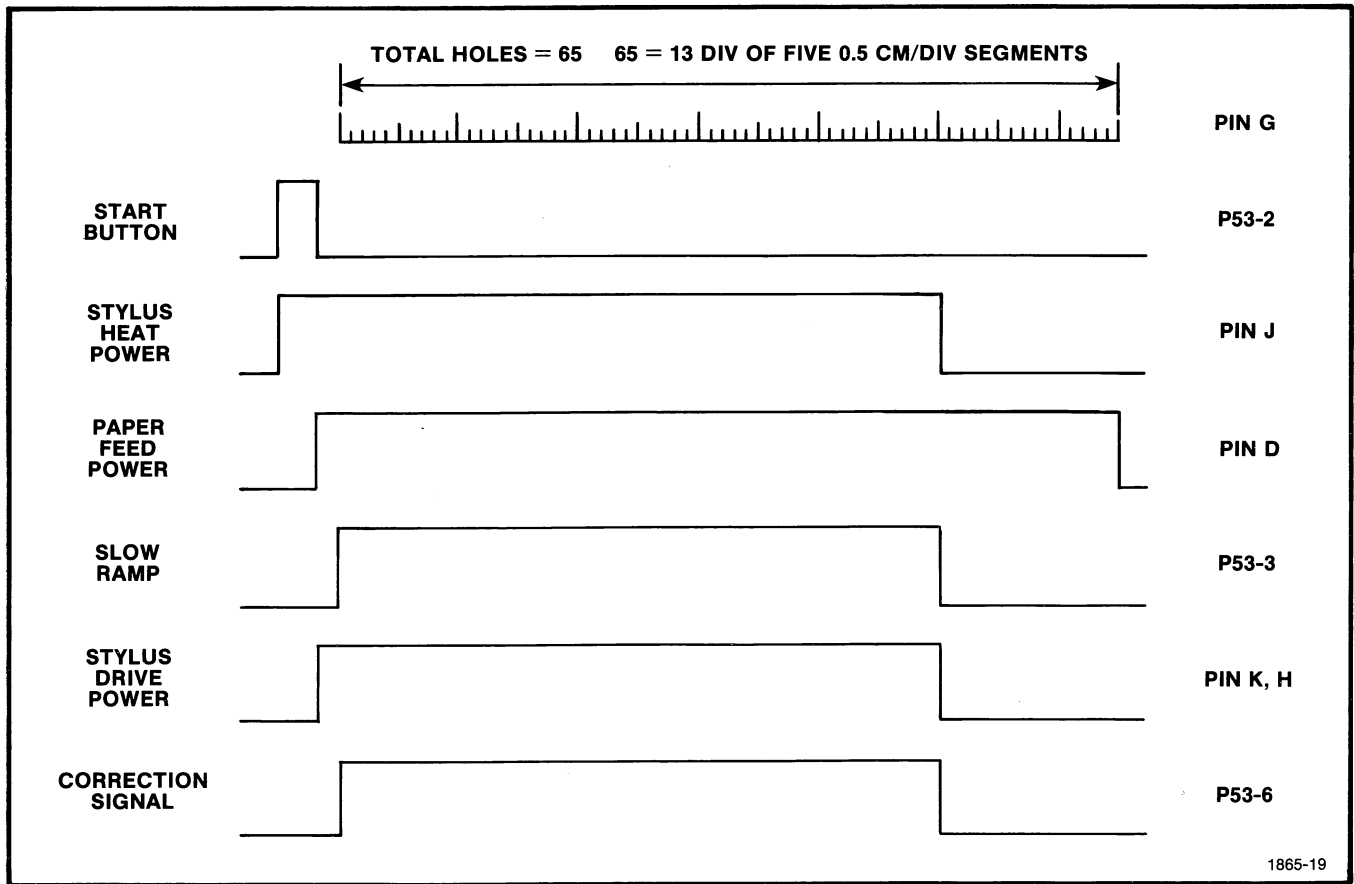

Fig. 3-7. Chart Recorder logic.

turns the stylus heat off. This signal brings the flip-flop back to its original state (where pin 1 is low). The "Q" output also controls the chart pen motor power switch as well as providing the "J" input to flip-flop U5127B.

U5127B controls the start of the Slow Ramp Generator and controls the horizontal correction signal disable network (Q5112) and the power switch to the chart pen drive. The Slow Ramp Generator starts when Q2 of the Counter goes high. The output "Q" of U5127A enables U5127B to be clocked by Q2. When clocked, the pin 15 output of U5127B raises the HORIZ CONTROL line, while the pin 14 output enables the horizontal correction circuit by means of Q5112. The Q output of U5127A enables the heat and pen drive power when high.

Q5237 and Q5229 act as a dc level shift amplifier between flip-flop U5127B and the Slow Ramp Generator, which is on the Vertical board. Q5226 senses when the chart recorder is plugged in.

Chart Recorder Power Switch. The plus or minus 8 V to drive the stylus movement is applied to the Strip Chart Recorder through two electronic switches, Q5273 and Q5277. Q5179 parallels Q5273 to provide more current in the +8 V line. These switches are driven by the same signal that is used to control stylus heat switch Q5239. This signal is passed through Q5173 and Q5279 to the switches.

Anti-Bounce Record. This circuit, consisting of U5156A and Q5156D, removes switching transients from the RECORD switch. The output of this circuit goes to the Vertical board to control the X-Y Record Logic. The Record Logic in turn provides the logic control signal that is received through pin 2 of P53 on the Logic board. If the Logic board is removed from the TDR unit, the harmonica connector from the RECORD switch should be connected to P28 on the Vertical board.

X-Y Output Module

The X-Y Output Module provides an electrical interface between the 1503 and an external X-Y Chart Recorder. Three signals, PEN LIFT, X Output, and Y Output are provided for use by the external Chart Recorder.

The switching mechanisms for the outputs are solid state devices, therefore care should be taken when connecting loads to them. See the specifications listed in the Characteristics section of this manual.

Pen Lift. The Pen Lift signal level changes when the RECORD switch is activated. The normal level is either $0.0\text{ V} \pm 0.5\text{ V}$ or $5\text{ V} + 0$ or -1 V , depending on how the terminal link of the X-Y Output Module board is connected (positive or negative slope, see Fig. 3-9). When the RECORD switch is activated, the level will change from 0 V to 5 V or from 5 V to 0 V . The driving capability of this signal source is given in the Characteristic section of this manual.

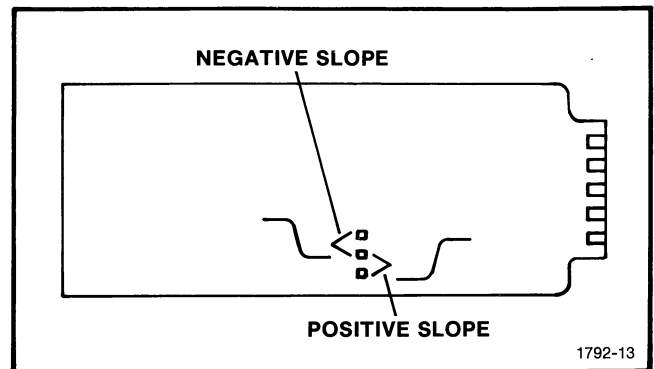

Fig. 3-8. X-Y Output Module strap.

Diode CR7247 is used to clamp the negative voltage swing to -0.6 V . Q7242 provides the capabilities for the operation of units with a positive pen lift or a ground return path.

X Output. The X output is proportional to the horizontal position of the crt beam along the crt face. This signal is a ramp of approximately 20 s duration and raises at a rate of 0.1 V for each division of horizontal travel across the crt. This 0.1 V per division scale factor is set by a voltage divider network comprised of R7138, R7129 and R7122. C7132 is used to reduce noise. Source impedance is less than 13 K (9.4 K minimum).

Y Output. The Y output is proportional to the vertical deflection on the crt. The scale factor (volts output per division of crt deflection) is adjustable, from 0.09 V per division to 0.13 V per division (factory set for 0.1 V/div), by variable resistor R7225. The source impedance of this signal is less than $11\text{ k}\Omega$ ($8\text{ k}\Omega$ minimum) and is determined by R7234, R7224 and R7225. C7232 is used to reduce noise.



CALIBRATION PROCEDURE

PERFORMANCE CHECK PROCEDURE

Calibration Interval

To ensure accuracy, check the calibration of the 1503 every 1000 hours of operation, or every six months if used infrequently. Before complete calibration, thoroughly clean and inspect this instrument.

Tektronix Field Services

Tektronix, Inc. provides complete instrument repair and recalibration at local Field Service Centers and Factory Service Centers. Contact your local Tektronix Field Office or representative for further information.

Using this Procedure

Performance Check. The performance check of this instrument can be made by performing all steps of the performance check. The 1503 can be checked for basic operation by using a cable of known length, impedance, and dielectric, but an accurate check requires removing the case and using the performance check. Whenever the case is removed, it must be resealed using the procedure listed at the end of the Calibration Procedure to maintain watertight integrity.

Partial Calibration. A partial calibration step is often desirable after replacing components. To prevent unnecessary recalibration of other steps, be sure the instrument settings are correct by referring to previous steps.

Complete Calibration. Completion of each step in this procedure ensures that this instrument is correctly adjusted and performing within all given tolerances.

NOTE

When other equipment is substituted, control settings or calibration set up may need to be altered to meet the requirements of the substituted equipment.

Preliminary Procedure

Remove the battery pack from the rear of the 1503 case. Remove the front cover of the 1503.

Loosen the four screws at the rear of the case and set the unit face up. Push down on the handle to break the seal; then place it face down on a flat surface. Take hold of the sides of the case and pull to remove the case from the unit.

Remove the EMI shields from the top and bottom of the unit. Place the battery pack in the rear of the 1503, taking care that the polarity is correct. Connect the ac power cord to the ac outlet, at the rear of the unit, and to a 115 V ac (230 V ac for Option 6) power source.

WARNING

Extreme caution must be used when operating the 1503 with the covers removed. Up to 170 V may be encountered in exposed areas.

Pull the POWER switch to turn the unit on and allow 20 minutes warm-up before proceeding with the calibration.

Table 4-1

LIST OF TEST EQUIPMENT REQUIREMENTS

Description	Performance Requirements	Applications	Example
Power Module		Must be used with all TM 500 plug-ins	TEKTRONIX TM 503 or TM 504
Digital Voltmeter	Range 0-200 V, $\pm 0.1\%$ accuracy	Voltage Measurements	TEKTRONIX DM 505 or DM 502A
Pulse Generator	0.1 ms, 0 to 5 V Output, External Trigger	Timing	TEKTRONIX PG 501
Sinewave Oscillator	200 Hz, 0-10 V into 50 Ω	Vertical Attenuation	TEKTRONIX FG 503
Oscilloscope	5 MHz Bandwidth, 10 mV/Div Vertical Sensitivity	Horizontal	TEKTRONIX SC 501
Step Attenuator	0-50 dB, 0.5% accuracy	Vertical Attenuation	TEKTRONIX 2701 Attenuator
50 Ω Termination (feed through)	50 $\Omega \pm 2\%$	General	Tektronix Part No. 011-0049-01
Adapter bnc female-to-bnc female		General	Tektronix Part No. 103-0028-00
Coaxial Cables (2 required)	50 Ω , 42 inch bnc connectors	General	Tektronix Part No. 012-0057-01
75 Ω Termination	75 $\Omega \pm 2\%$	Vertical Check	Tektronix Part No. 011-0055-00

PERFORMANCE CHECK

1. Vertical Attenuation Check

Control Settings:

RET LOSS	0 dB
NOISE FILTER	Out
0-dB SET	Clockwise
Distance Dial	000
FEET/DIV	0.5
(METRES/DIV)	(1)
CABLE DIELECTRIC	Both Out
VAR	Clockwise

a. Disconnect P21 from the Vert Amp/Slow Ramp board.

b. Connect the sine-wave output from the FG 503 through the 2701 attenuator to P21 on the Vert Amp board. It may be necessary to ground the chassis of the 1503 to the FG 503.

c. Set the FG 503 to a 200 Hz sine wave.

d. Set the 1503 RET LOSS to 0 dB. Set the 0-dB SET fully cw, set the 2701 to 0 dB, and set the FG 503 for a 6 division display.

e. The crt should display a sine wave for each of the following settings of the 1503 RET LOSS switch and the 2701 attenuator switch:

RET LOSS	2701 ATTEN	Display
0 dB	0 dB	6 div ± 0.2 div
10 dB	10 dB	6 div ± 0.2 div
20 dB	20 dB	6 div ± 0.2 div
30 dB	30 dB	6 div ± 0.2 div
40 dB	40 dB	6 div ± 0.2 div
50 dB	50 dB	6 div ± 0.2 div
60 dB	60 dB	6 div ± 0.2 div

f. Remove the test leads and replace P21.

2. Display Noise Check

- a. Set RET LOSS to 0 dB.
- b. Connect the 50 Ω terminator to the CABLE connector and press the 50 Ω impedance button.
- c. Set FEET/Div to 5, multiplier to X100, and press the 1000 ns IMPLS WIDTH button.
- d. Set 0 dB SET control for a 2 division display.
- e. Set the IMPLS WIDTH to 10 ns. Turn the ZERO REF SET control fully clockwise.
- f. Set the RET LOSS to 78 dB and adjust the POSITION controls so the base line is located on the crt center line.
- g. Check that the peak-to-peak noise is not greater than 3 divisions (-80 dB rms). Ignore occasional spikes.
- h. Push the NOISE FILTER button in and check that the peak-to-peak noise is less than 1.5 divisions (-86 dB rms).

3. X10 Timing Check

- a. Set the RET LOSS to 20 dB and the multiplier to X10. Set FEET/DIV to 50.
- b. Connect the TG 501 Time Mark Generator through a 50 Ω terminator to the CABLE connector on the 1503. Set the TG 501 to 1 μ s marks.
- c. Connect the + TRIGGER OUT from the TG 501 to the TRIG/DURATION IN on the PG 501 pulse generator. Set the PG 501 PERIOD control to EXT TRIG, the DURATION control to 0.1 ms and the -OUTPUT control to 5 V into 50 Ω (10 V into 1 M Ω).
- d. Connect the -OUTPUT from the PG 501 to the EXT CAL terminals on the Main Board (see Fig. 4-6).
- e. Set the 1503 ZERO REF SET so that the test pulse is off screen (left) and there is one time-mark per graticule line.
- f. Check for 8 time marks in 7.9 divisions.

4. DISTANCE Dial Check

- a. Set the FEET/DIV switch to 5 feet.
- b. Turn the ZERO REF SET control clockwise, stopping when the last time-mark pulse is seen before the fully clockwise stop on the control is reached. Set the leading edge of the marker on the second graticule line from the left.
- c. Set the DISTANCE dial to 050.
- d. Check that the leading edge of the second pulse seen as the DISTANCE dial is turned lines up on the second graticule line from the left.
- e. Check that when the DISTANCE dial is turned from 050 to 100, 150, 200, and 250 that each marker pulse is located on the reference line within $\pm 2\%$ of the dial reading, ± 1 digit.

5. Check Cable Dielectric Settings

- a. Set the FEET/DIV switch to 5 feet and the multiplier to X10. Select 1 μ s markers from the TG 501.
- b. Press the SOLID POLY dielectric button and position a time mark on the second graticule line from the left with the ZERO REF SET control.
- c. Check that the two markers are 6.46-6.72 divisions apart.
- d. Press the FOAM POLY dielectric button.
- e. Check for 7.94-8.26 division between the two pulses.
- f. Switch back to AIR dielectric (both buttons out).

6. Check X100 Timing

- a. Set the FEET/DIV switch to 5 feet and the multiplier to X100. Set the TG 501 for 1 μ s markers.
- b. Check for eight markers in 7.84-8.16 divisions.
- c. Remove the cables from the 1503. Replace the EXT CAL connector.

ADJUSTMENT PROCEDURE

Introduction

Use this Adjustment Procedure to restore the 1503 to original performance requirements. This adjustment Procedure need not be performed unless the instrument fails to meet the Performance Requirements of the electrical characteristics listed in the Specification section, or if the Performance Check procedure cannot be completed satisfactorily. If the instrument has undergone repairs, the Adjustment Procedure is recommended.

Satisfactory completion of all adjustment steps in this procedure ensures that the instrument will meet the Performance Requirements.

Test Equipment Required

The test equipment (or equivalent) listed in Table 4-1 is required for adjustment of the 1503. Specifications given for the test equipment are the minimum necessary for accurate adjustment. All test equipment is assumed to be correctly calibrated and operating within specifications.

If other test equipment is substituted, calibration setup may need to be altered to meet the requirements of the equipment used.

POWER SUPPLY

Control Settings. Preset the front panel controls as follows:

ZERO REF SET	Fully cw
POSITION	Midrange
RET LOSS (dB)	0
NOISE FILTER	Out
0-dB SET	cw
DISTANCE Dial	000
FEET/DIV	.5
(METRES/DIV)	(1)
MULTIPLIER	X10
FOCUS and INTENSITY	Adjust for clear bright trace
CABLE DIELECTRIC	
SOLID POLY	Out
FOAM POLY	Out
VAR	Fully cw

Place the DM 501 Digital Multimeter in the TM 503 Power Module. Plug in the TM 503 to an ac power source and pull the PWR switch on.

Set the DM 501 RANGE/FUNCTION control to 200 DC VOLTS. Connect the test leads to the HI and LO INPUT terminals.

1. Voltage Measurements

a. Connect the lead from the DM 501 LO terminal to TP6332 (black test point) on the 1503 Power Supply board.

b. Connect the lead from the DM 501 HI terminal to TP6256, Fig. 4-1, (red test point).

c. ADJUST—R6358 (HV ADJ) so the voltmeter reads $+25\text{ V} \pm 0.25\text{ V}$.

d. Move the HI test lead to TP6411 (violet test point).

e. Change the DM 501 RANGE/FUNCTION switch to 20 V dc.

f. ADJUST—R6514 (+10 ADJ) so the voltmeter reads $+10\text{ V} \pm 0.1\text{ V}$.

g. Move the HI test lead to TP6227 (green test point).

h. CHECK—That the voltmeter reads $+5\text{ V} \pm 0.25\text{ V}$.

i. Move the HI test lead to TP6218 (orange test point).

j. CHECK—That the voltmeter reads $-5\text{ V} \pm 0.25\text{ V}$.

k. Change the DM 501 RANGE/FUNCTION switch to 200 V dc.

l. Move the HI test lead to connector P66 Pin 6.

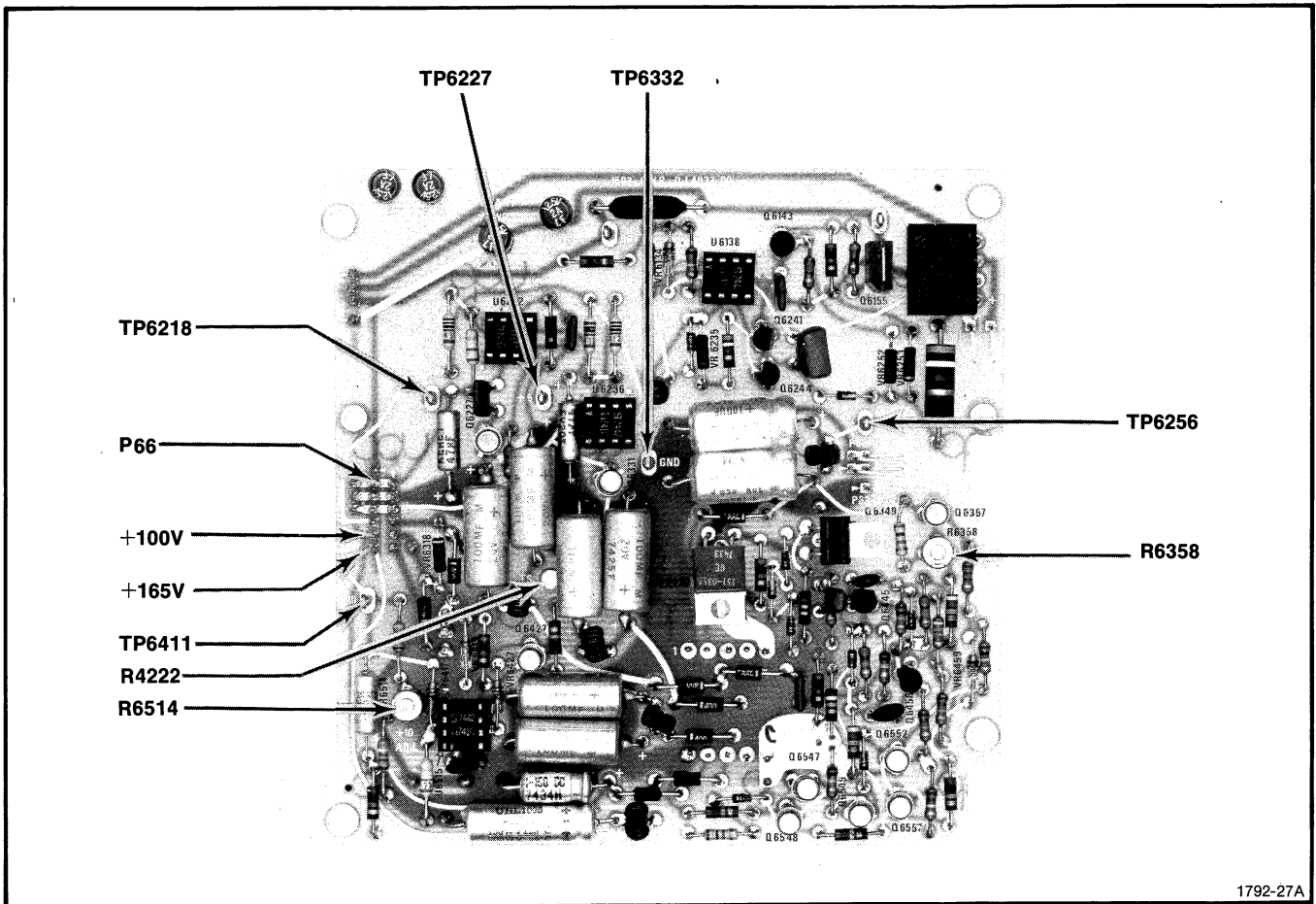

Fig. 4-1. Power Supply test points and adjustment location.

m. CHECK—That the voltmeter reads $+100\text{ V} \pm 10\text{ V}$.

n. Move the HI test lead to P66 Pin 7.

o. CHECK—That the voltmeter reads $+165\text{ V} \pm 10\text{ V}$.

p. Remove the voltmeter test leads.

The following parts q through t apply to instruments of SN B071995 and below. Proceed to parts u through y for instruments of SN B071996 and up.

q. Set the INTENSITY control fully cw and note display.

r. CHECK—For maximum intensity without trace blooming.

s. ADJUST—R4222 (INTENSITY LIMIT) for maximum intensity without trace blooming. The adjustment is located on the HIGH VOLTAGE board and adjusted through the hole in the POWER SUPPLY board (See Fig. 4-1).

t. Set INTENSITY for normal trace brightness.

The following parts u through y apply to instruments of SN B071996 and up.

u. Connect the voltmeter between TP4243 and TP4251 (see Output Amp-High Voltage Component pull-out page for test point locations).

v. Set the INTENSITY control fully cw.

w. CHECK—For a voltmeter reading of $95\text{ mV} \pm 5\text{ mV}$.

**Calibration Procedure—1503
Adjustment Procedure**

x. ADJUST—R4222 (INTENSITY LIMIT) for a voltmeter reading that is inside the range of 90 mV to 100 mV. The adjustment is located on the HIGH VOLTAGE board and adjusted through the hole in the POWER SUPPLY board (see Fig. 4-1). Check for maximum intensity without trace blooming.

y. Set INTENSITY for normal trace brightness.

DISPLAY

Control Settings. Preset the front panel controls as follows:

RET LOSS 0 dB
NOISE FILTER Out
0-dB SET Clockwise
DISTANCE Dial 000
FEET/DIV .5
(METRES/DIV) (1)
Multiplier X10 (X1)
CABLE DIELECTRIC Both out
VAR Clockwise

2. Trace Focus and Astigmatism

a. Attach the 50 Ω termination to the CABLE connector.

b. With the ZERO REF SET control, set the pulse near mid screen.

c. Set the trace with the POSITION control on the center of the graticule.

d. ADJUST—R3242 (AST is located on the OUTPUT AMPS board) and the front panel FOCUS control until the clearest possible trace, both vertically and horizontally, is obtained.

3. Trace Rotation

a. Turn the ZERO REF SET fully clockwise so that just the horizontal base line is located on the horizontal center line.

b. CHECK—That the trace aligns with the crt horizontal center graticule line.

c. ADJUST—R3143 (ROT is located on the OUTPUT AMPS board) so that the trace aligns with the crt horizontal center graticule line.

4. Trace Geometry

a. Move the trace with the POSITION controls so that it is located three divisions below the horizontal center line.

b. CHECK—That the trace aligns with the graticule line (has no bow).

c. Move the trace with the POSITION controls so that it is located three divisions above the horizontal center line.

d. CHECK—That the trace aligns with the graticule line (has no bow).

e. ADJUST—R3248 (GEO is located on the OUTPUT AMPS board) for the least possible bow in the two positions; three divisions above and three divisions below the horizontal center line.

f. Recheck the trace rotation and focus.

VERTICAL

Control Settings

RET LOSS	0 dB
NOISE FILTER	Out
0 dB SET	Clockwise
DISTANCE Dial	000
FEET/DIV	.5
(METRES/DIV)	(1)
Multiplier	X10 (X1)
CABLE DIELECTRIC	Both out
VAR	Clockwise

5. Vertical Attenuation Check

a. Disconnect P21 from Vert Amp/Slow Ramp board.

b. Connect the sine wave output through the 2701 attenuator from the FG 503 to P21 on the VERT AMP board. It may be necessary to ground the chassis of the 1503 to the FG 503.

c. Set the FG 503 to a 200 Hz sine wave.

d. Set the 1503 RET LOSS to 0 dB, set the 0-B SET fully cw. Set the 2701 to 0 dB, and set the FG 503 VAR ATTEN for a six division display.

e. CHECK—The crt should display a sine wave for each of the following settings of the RET LOSS switch on the 1503 and the STEP ATTENUATOR switch on the 2701 attenuator:

RET LOSS	2701 ATTEN	DISPLAY
0 dB	0 dB	6 div ± 0.2 div
10 dB	10 dB	6 div ± 0.2 div
20 dB	20 dB	6 div ± 0.2 div
30 dB	30 dB	6 div ± 0.2 div
40 dB	40 dB	6 div ± 0.2 div
50 dB	50 dB	6 div ± 0.2 div
60 dB	60 dB	6 div ± 0.2 div

f. Remove the test leads from the VERT AMP board and replace P21.

g. To the CABLE input, connect a 42-inch coaxial cable, a female to female adapter, a second 42-inch coaxial cable, to a 75 Ω termination.

h. Press in the 50 Ω and 75 Ω impedance buttons, set RET LOSS to 0 dB and IMPLS WIDTH to 10, and set 0-dB SET for a one division display.

i. Set the fine RET LOSS control to 18 dB and check for an eight division display. If the display is not eight divisions, ± 1 division, select the value of R1603 between 1.5K and 1.8M.

j. Set the fine RET LOSS control to 0 dB and remove the termination and cables.

6. Vertical Gain Check

a. Set RET LOSS to 0 dB.

b. Set 0-dB SET control counterclockwise and note amplitude of test pulse.

c. Set 0-dB SET control clockwise.

d. CHECK—Test pulse amplitude should be at least four times greater than that at the counterclockwise position.

7. Sampling Efficiency and Blow-by

a. Connect the 50 Ω terminator to the CABLE connector and press the 50 Ω impedance button.

b. Set RET LOSS to 0 dB, FEET/DIV to five feet, multiplier to X100, and press the 1000 ns IMPLS WIDTH button.

c. Set 0-dB SET control for a two division display.

d. Press the 100 ns IMPLS WIDTH button and ADJUST R1693—SAMPLING EFFICIENCY—so the peak of the pulsing display does not rise above two graticule divisions (see Fig. 4-2).

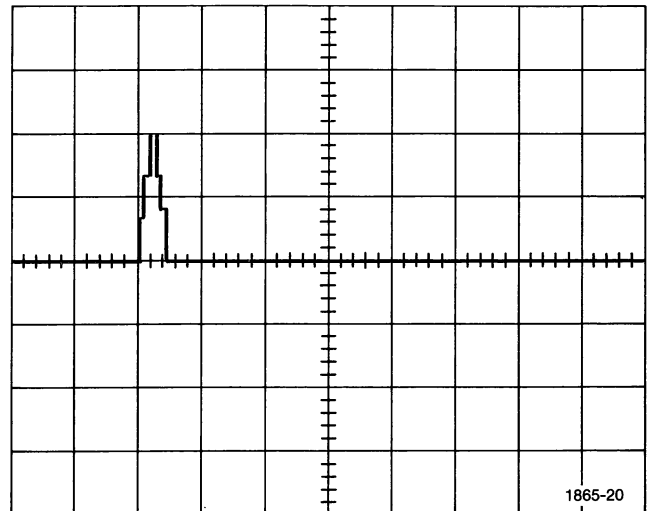

Fig. 4-2. Sampling Efficiency Pulse.

e. Set the RET LOSS switch to 60 dB.

f. ADJUST—R1796 1st BLOW-BY COMP for a straight base line (no positive or negative pulse) at approximately 2000 feet before the test pulse (see Fig. 4-3a).

g. With the ZERO REF SET control, move the pulse off screen to the right. Set RET LOSS to 78 dB. (Set the fine RET LOSS control to 18 dB.)

h. ADJUST—R1406 2nd BLOW-BY for minimum noise on the base line (see Fig. 4-4a).

i. Set RET LOSS to 30 dB, IMPLS WIDTH to 1000 ns, and center the leading edge of the pulse on the vertical center line.

**Calibration Procedure—1503
Adjustment Procedure**

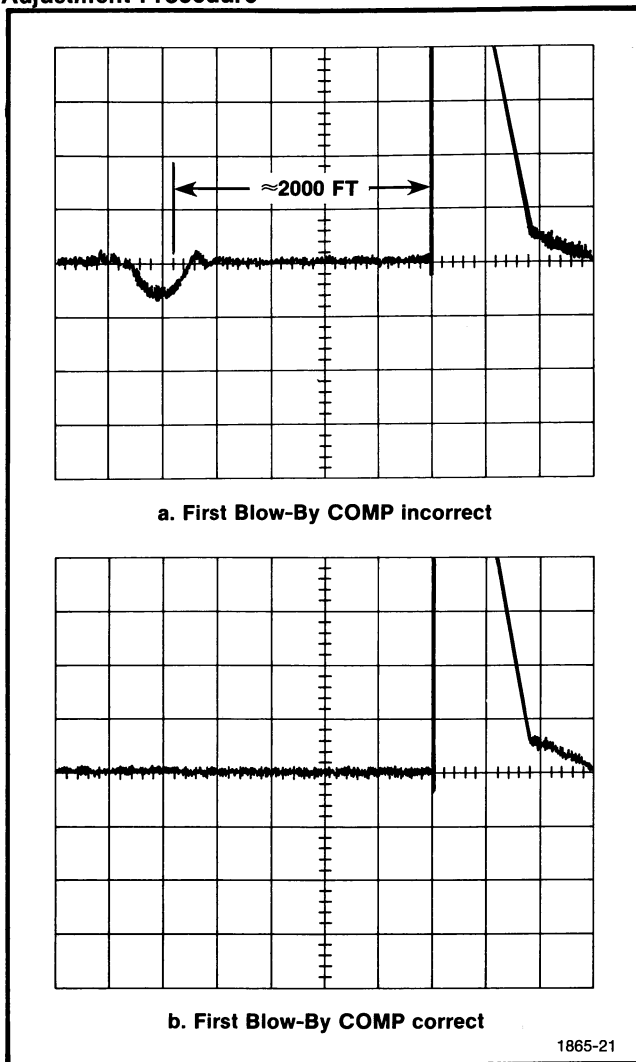

Fig. 4-3. First Blow-by Compensation Adjustments.

j. CHECK—The trailing edge of the pulse should not be greater than two divisions (see Fig. 4-4b).

8. Check Display Noise

a. Set IMPLS WIDTH to 10 ns. Turn the ZERO REF SET control fully counterclockwise.

b. Set the RET LOSS to 78 dB and adjust the POSITION controls so the base line is located on the crt center line.

c. CHECK—That the peak-to-peak noise is not greater than three division (78 dB rms). Ignore occasional spikes.

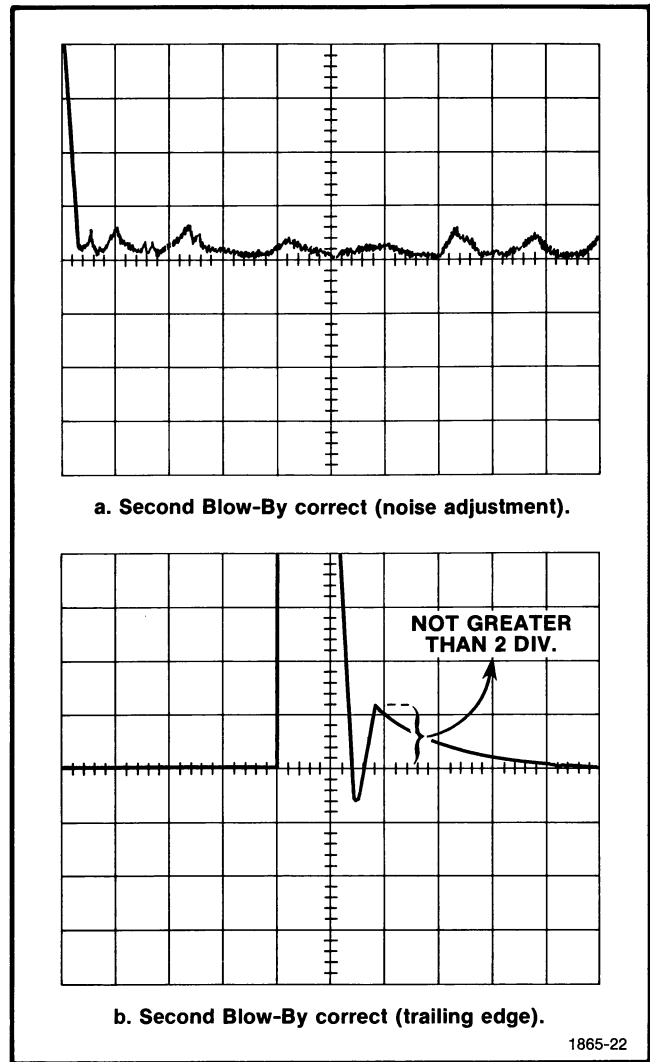

Fig. 4-4. Second Blow-by Compensation Adjustments.

d. Push the NOISE FILTER button in and check that the peak-to-peak noise is less than 1.5 divisions (84 dB rms).

**HORIZONTAL—STANDARD VERSION
(See Step 17 for metric version)**

Control Settings

RET LOSS	0 dB
NOISE FILTER	Out
0-dB SET	Clockwise
DISTANCE Dial	000
FEET/DIV	50
Multiplier	X100
CABLE DIELECTRIC	Both out
VAR	Clockwise

9. FAST RAMP

a. Connect the test oscilloscope test probe to the front lead of C1238 (see Fig. 4-5).

b. CHECK—For a peak-to-peak amplitude of 6 V, ± 0.2 V. Ramp should begin at an approximate -2 V level and ramp should end at an approximate $+4$ V.

c. ADJUST—R1676 (RAMP PEAK) for a peak-to-peak amplitude of 6 V, ± 0.2 V with the ramp beginning at an approximate -2 V level and ramp ending at an approximate $+4$ V level (see Fig. 4-5).

d. Remove the test probe.

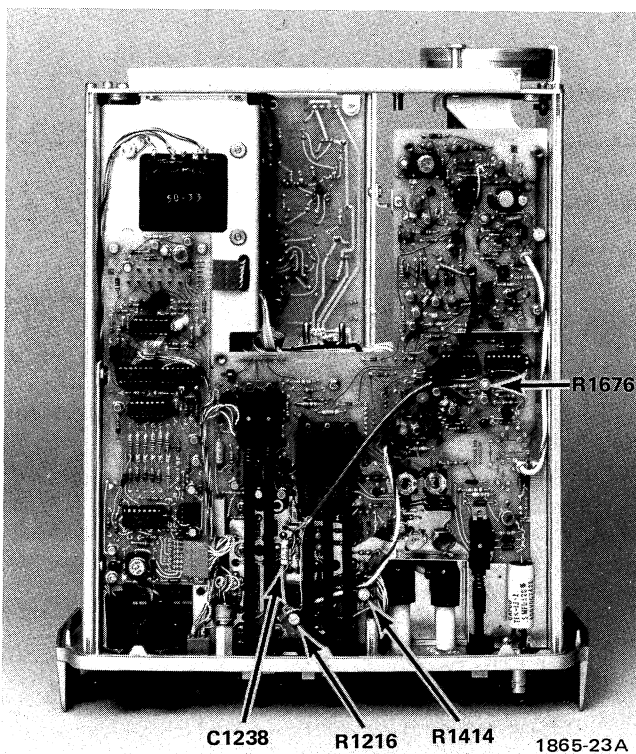

Fig. 4-5. Fast Ramp test point.

10. Timing

a. Set RET LOSS to 20 dB and the multiplier to X10.

b. Connect the TG 501 Time Mark Generator through a 50- Ω terminator to the CABLE connector on the 1503. Set the TG 501 to 1 μ s marks.

c. Connect + TRIGGER OUT from TG 501 to TRIG/DURATION IN on PG 501 Pulse Generator. Set PG 501 PERIOD to EXT TRIG, DURATION to 0.1 ms, and - OUTPUT control to 5 V into 50 Ω (10 V into 1 M Ω).

d. Connect the - OUTPUT from the PG 501 to the EXT CAL terminals on the Main Board (see Fig. 4-6).

e. Set the 1503 ZERO REF SET so that the test pulse is off screen. (left) and the time marks are set one per graticule line.

f. CHECK—For 8 time marks in 7.9 divisions.

g. ADJUST—R1216 (FT/DIV CAL) for eight time marks in 7.9 divisions (see Fig. 4-5).

11. DISTANCE Dial

a. Set the FEET/DIV switch to 5 feet.

b. Turn the ZERO REF SET control clockwise, stopping when the last time mark pulse is seen before fully clockwise is reached and set its leading edge on the second graticule line from the left.

c. Set the DISTANCE dial to 050.

d. CHECK—That the leading edge of the second pulse, seen as the DISTANCE dial is turned, lines up on the second graticule line from the left.

e. ADJUST—R1414 DIST CAL to position the leading edge of the pulse on the second graticule line (see Fig. 4-5). Check that the pulse is at the same point on the graticule when the ZERO REF CHECK button is pressed.

f. CHECK—That when turning the DISTANCE dial from 050 to 100, 150, 200, and 250 that each marker pulse is located on the reference line within ± 1 digit of the dial.

12. Cable Dielectrics

a. Set the FEET/DIV switch to five feet, multiplier to X10. Select 1 μ s markers.

b. Press the SOLID POLY dielectric button and position a time mark on the second graticule line from the left with the ZERO REF SET control.

c. CHECK—That the two markers are 6.39-6.79 divisions apart.

d. Press the FOAM POLY dielectric button.

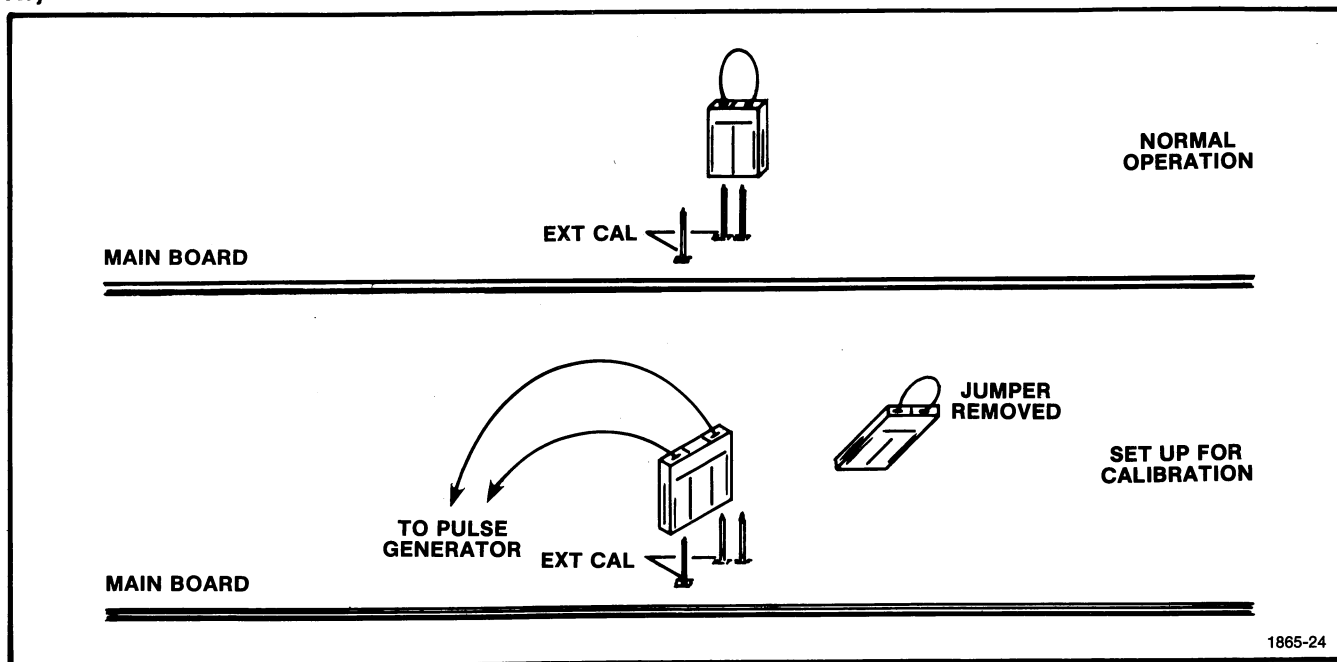

Fig. 4-6. External Calibration connection.

e. CHECK—For 7.9-8.3 divisions between the two pulses.

f. Switch back to AIR (both out).

13. X100 Timing

a. Set the FEET/DIV switch to five feet and the multiplier to X100. Set the TG 501 for 1 μ s markers.

b. CHECK—For one marker per division $\pm 2\%$.

c. Remove cables from the 1503. Replace the EXT CAL connector.

14. X100 Position

a. Set IMPLS WIDTH for 100 ns pulse, RET LOSS to 0 dB.

b. With ZERO REF SET position the pulse leading edge on the graticule center line.

c. CHECK—That the pulse start remains at the center line when switching from X100 to X10.

d. ADJUST—R1132 while in the X10 position so that the pulse remains at the center line when switching between X10 and X100.

15. ZERO REF SET

a. Set FEET/DIV to 50, multiplier to X10, and IMPLS WIDTH to 1000.

b. Rotate ZERO REF SET fully counterclockwise and then fully clockwise.

c. CHECK—The leading edge of the pulse should move at least past the second vertical graticule line from the left.

HORIZONTAL—METRIC VERSION (See Step 9 for Standard Version)

Control Settings

RET LOSS	0 dB
NOISE FILTER	Out
0-dB SET	2 div pulse
DISTANCE Dial	000
METRES/DIV	50
Multiplier	X10
CABLE DIELECTRIC	Both out
VAR	Fullyclockwise

16. FAST RAMP

a. Connect the test oscilloscope test probe to the front lead of C1238 (see Fig. 4-7).

b. CHECK—For a peak-to-peak amplitude of 6 V \pm 0.2 V. Ramp should begin at an approximate -2 V level and ramp should end at an approximate $+4$ V level.

c. ADJUST—R1676 (RAMP PEAK) for a peak-to-peak amplitude of 6 V \pm 0.2 V with the ramp beginning at an approximate -2 V level and ramp ending at an approximate $+4$ V level (see Fig. 4-7).

d. Remove the test probe.

17. Horizontal Gain and OFFSET

a. Use the POSITION controls to center the trace on the graticule.

b. Set R3217 (HORIZ—located on the OUTPUT AMPS board) to the counterclockwise stop.

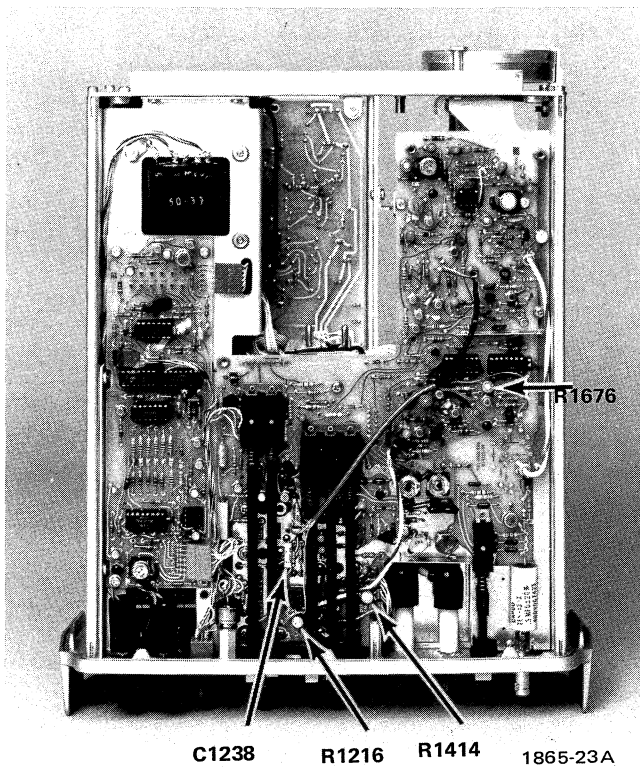

Fig. 4-7. Fast Ramp test point.

c. ADJUST—R3221 (H POS—located on the OUTPUT AMPS board) to center the trace on the graticule.

d. ADJUST—R3217 (HORIZ) so that the retrace at the start of the sweep is just off the graticule area and the trace covers all ten divisions of the graticule.

18. Timing

a. Set RET LOSS to 20 dB, and the multiplier to X1.

b. Connect the TG 501 Time Mark Generator through a 50 Ω terminator to the CABLE connector on the 1503. Set the TG 501 to 1 μ s marks.

c. Connect + TRIGGER OUT from the TG 501 to TRIG/DURATION IN on the PG 501 Pulse Generator. Set the PG 501 PERIOD to EXT TRIG, DURATION to 0.1 ms, and $-$ OUTPUT control to 5 V into 50 Ω (10 V into 1 M Ω).

d. Connect the $-$ OUTPUT from the PG 501 to the EXT CAL terminals on the 1503 Main Board (see Fig. 4-8).

e. Set the 1503 ZERO REF SET so that the test pulse is off screen (left) and the time marks are set one per graticule line. Use the VARIABLE PULSE DURATION control on the PG 501 to obtain stable time marks.

f. CHECK—Each time mark should align with every third graticule line.

g. ADJUST—R1216 FT/DIV CAL for one mark per every third division.

19. DISTANCE Dial

a. Set the METRES/DIV switch to 10 metres.

b. Turn the ZERO REF SET control clockwise, stopping when the last time mark pulse is seen before fully clockwise is reached and set its leading edge on the second graticule line from the left.

c. Set the DISTANCE dial to 150.

d. CHECK—That the leading edge of the second time mark pulse, as seen as the DISTANCE dial is turned, lines up on the second graticule line from the left.

e. ADJUST—R1414 DIST CAL to position the leading edge of the time mark pulse on the second graticule line. Check that the pulse is at the same point on the graticule when the ZERO REF CHECK button is pressed.

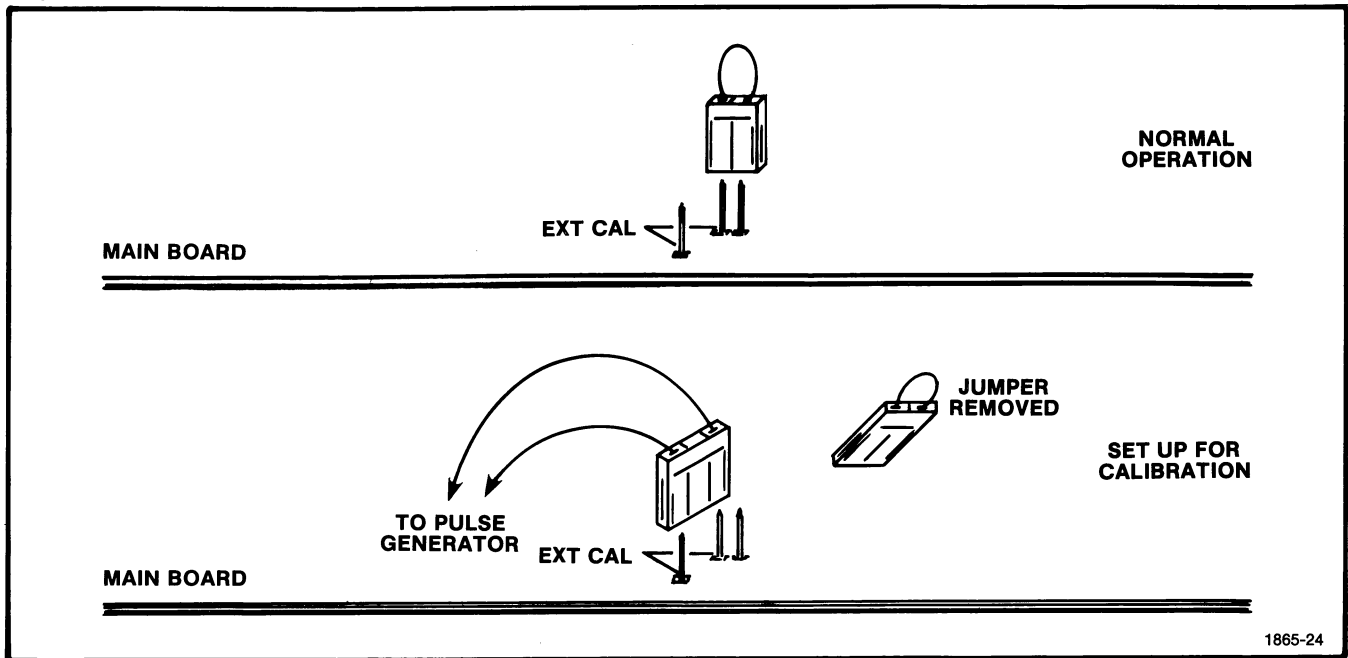

1865-24

Fig. 4-8. External Calibration connection.

f. CHECK—That when turning the DISTANCE dial from 150 to 300 and 450 that each marker pulse is located on the reference line within ± 1 digit of the dial.

20. Cable Dielectrics

a. Set the METRES/DIV switch to 25, the multiplier to X1, and select $1 \mu\text{s}$ markers.

b. Select SOLID POLY dielectric and position a time marker on the second graticule line from the left using the ZERO REF SET control.

c. CHECK—That the markers are 3.75-4.15 division apart.

d. Select the FOAM POLY dielectric.

e. CHECK—For 4.66-5.06 divisions between pulses.

f. Switch the CABLE DIELECTRIC buttons back to AIR (both out).

21. X10 Timing

a. Set the METRES/DIV switch to five metres, and the multiplier to X10. Set the TG 501 for $1 \mu\text{s}$ markers.

b. CHECK—For one marker every third division $\pm 2\%$.

c. Remove cables from the 1503. Replace the EXT CAL connector.

22. X1 Position

a. Set IMPLS WIDTH for 1000 ns pulse and RET LOSS to 0 dB.

b. With ZERO REF SET position the pulse leading edge on the graticule center line.

c. CHECK—That the pulse start remains at the center line when switching from X10 to X1.

d. ADJUST—R1132 while in the X1 position so that the pulse remains at the center line when switching between X1 and X10.

X-Y OUTPUT MODULE

Control Settings

RET LOSS	0 dB
NOISE FILTER	Out
0-dB SET	2 div pulse
DISTANCE Dial	000
FEET/DIV	.5

(METRES/DIV)	(1)
Multiplier	X10 (X1)
CABLE DIELECTRIC	SOLID POLY
IMPLS WIDTH	10

Connect the 50 Ω terminator to the 1503 CABLE connector.

23. Pen Lift Signal

a. Set the Digital Multimeter RANGE/FUNCTION control to 20 on the DC VOLTS scale.

b. Place the terminal connection link of the OUTPUT MODULE board on the negative slope terminals (see Fig. 4-9).

c. Connect the lead from the DVM HI terminal to the X-Y OUTPUT MODULE PEN LIFT red terminal and the lead from the DVM LO terminal to the X-Y OUTPUT MODULE PEN LIFT black terminal.

d. CHECK—That the DVM shows approximately +5 V.

e. Momentarily push the RECORD switch to RECORD, then release the switch. Check that the voltage goes to +0.5 V or less and returns to approximately +5 V at the end of the sweep.

f. Move the terminal connection link to the positive slope terminals on the X-Y OUTPUT MODULE board.

g. CHECK—That the DVM reads approximately 0.5 V.

h. Push the RECORD switch to RECORD and check that the DVM reads +4 V or greater, then returns to approximately 0.5 V at the end of the sweep.

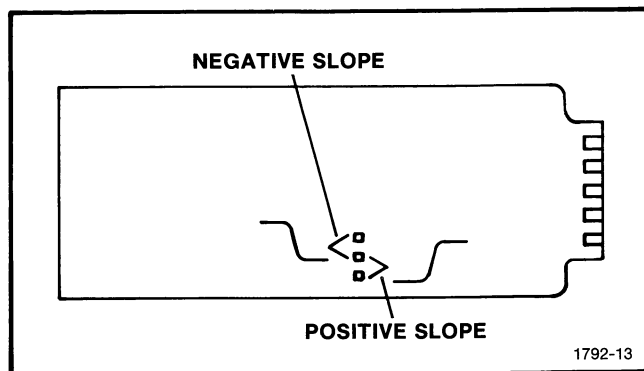

Fig. 4-9. X-Y Output Module strap.

24. Y OUTPUT

a. Move the test leads from the PEN LIFT terminals to the corresponding Y terminals of the X-Y OUTPUT MODULE.

b. Set IMPLS WIDTH to 100 ns and turn ZERO REF SET completely clockwise.

c. Push and hold the RECORD switch to RECORD and adjust the POSITION controls so that the DVM reads 0.0 V.

d. Turn ZERO REF SET slowly counterclockwise and check that the DVM rises to approximately +0.4 V. Release the RECORD switch.

e. ADJUST—R7225 (on X-Y OUTPUT MODULE board) until the DVM peaks at +0.4 V while holding the RECORD switch to RECORD and slowly rotating the ZERO REF SET control.

f. The dot on the left side of the crt should move one division for each 0.1 V read on the DVM.

25. X OUTPUT

a. Move the test leads to the X terminals.

b. Press the RECORD switch.

c. CHECK—That the voltage reads from 0 to 1 V (100 mV/div) as the dot moves across the screen.

REPLACING THE CASE ON THE 1503

To replace the case on the 1503, proceed as follows:

1. Remove any termination and adapters from the CABLE connector.

2. Remove the battery pack and power cord from the back of the 1503.

3. Place the EMI shields on the top and bottom of the 1503.

4. Stand the 1503 on its face. Lubricate the surface of the rubber seals around the edge of the subpanel with a waterproof lubricant.

**Calibration Procedure—1503
Adjustment Procedure**

5. Slide the case over the back of the unit, until it has reached the subpanel.

6. Tighten the four screws on the back of the case until the case is aligned with the groove at the back of the subpanel.

7. Make sure the case is in the groove; then, using a torque screwdriver, tighten the four screws to eight inch-pounds.

NOTE

If the screws are tightened more than eight inch-pounds, the case may crack. If the screws are not tightened equally to the required torque, the water-tight integrity of the case may be compromised.

8. Place the battery pack in its compartment and tighten the two screws (finger tight is sufficient).

9. Place the power cord and the rest of the accessories in the front cover storage compartment and latch it closed.

10. Place the front cover over the front cover panel and close the latches.

MAINTENANCE

NOTE

It is recommended that the 1503 be serviced at a Tektronix Service Center. The instrument should be serviced by a technician skilled in sampling and pulse techniques.

This section of the manual provides information used for preventive maintenance, corrective maintenance, and troubleshooting the 1503. The physical location of all circuit components on the circuit boards are shown on the circuit diagram pullout.

Preventive Maintenance

Preventive maintenance consists of cleaning, visual inspection, lubrication, etc. Preventive maintenance performed on a regular basis will help improve the reliability of the instrument. The severity of the environment to which the 1503 is subjected determines the frequency of needed maintenance. A convenient time to perform preventive maintenance is preceding recalibration of the instrument.

Cleaning

Accumulation of dirt in the instrument can cause overheating and component breakdown. Dirt on components acts as an insulating blanket and prevents efficient heat dissipation. It also provides an electrical conduction path.

NOTE

To remove the instrument cabinet, see Preliminary Procedure at the beginning of the Calibration procedure. When the cabinet is removed, the water-tight feature may be compromised when the case is reinstalled. See the instructions at the end of the Calibration procedure on replacing the case on the 1503.

Interior. The 1503 is constructed so that the interior of the instrument is protected from dust.

Therefore, the interior of the 1503 should not require cleaning unless the unit has been left with the front cover removed and the plug-in compartment empty. The best way to clean the interior is to blow off the accumulated dust with low-pressure air. Remove any dirt that remains with a soft brush or a cloth dampened with a mild

detergent and water solution. A cotton-tipped applicator is useful for cleaning in narrow spaces on circuit boards.

CAUTION

Avoid the use of chemical cleaning agents which might damage the plastics used in this instrument. Avoid chemicals which contain benzene, toluene, xylene, acetone or similar solvents.

Exterior. The cabinet exterior can be washed with soap and water and rinsed with clear water. Loose dust accumulated on the front panel is best removed with a small brush or a soft cloth dampened with a mild detergent and water solution. Abrasive cleaners should not be used on the front panel.

CRT Implosion Shield. The face of the crt can be cleaned by using ISOPROPYL ALCOHOL applied and wiped very gently dry with KENDALL "NEBRIL" non-woven wipes.

Lubrication

The reliability of potentiometers, switches and other moving parts can be maintained if they are kept properly lubricated. However, too much lubricant is as detrimental as too little lubricant. A lubrication kit containing the necessary lubricants and instructions is available from Tektronix, Inc.

Visual Inspection

Prior to recalibration, the 1503 should be inspected for such defects as broken connections, damaged circuit boards, improperly seated transistors or pin connectors, frayed cable shields and heat-damaged components.

The corrective procedures for most visible defects are obvious. Particular care should be taken if heat-damaged components are found. Overheating usually indicates other trouble in the instrument, so it is important that the cause of overheating be corrected to prevent recurrence of the damage.

Semiconductor Checks

Periodic checks of the semiconductors in the 1503 are not recommended. The best check of semiconductor performance is actual operation in the instrument. More details on checking semiconductor operation are given under troubleshooting.

Recalibration

To ensure accurate measurements, check the calibration of the 1503 after each 1000 hours of operation or every six months if used infrequently. In addition, replacement of components may necessitate recalibration of the affected circuits. The calibration procedure can be helpful in localizing troubles in the instrument. Problems may be found or corrected by recalibration.

Servicing the Battery

The battery pack should be inspected every six months or every 500 hours of operation, whichever occurs first. The entire battery pack should be replaced if venting or corrosion has occurred.

TROUBLESHOOTING

The following information is provided to facilitate troubleshooting of the 1503. Information contained in other sections of this manual should be used along with the following information to aid in locating defective components. An understanding of the circuit operation is helpful in locating troubles. See the Circuit Description section for information.

Troubleshooting Aids

Diagrams. Circuit diagrams and corresponding circuit boards are located on foldout pages at the rear of the manual. Section 7 contains the Electrical Parts List. From these schematics and parts lists, the component number, location, electrical characteristics and Tektronix, Inc. part number can be cross-referenced. The components that are located on the front panel are shown on the circuit diagrams with their front-panel titles enclosed in a block. Additional aids for troubleshooting can be found in the Calibration section of this manual.

COMPONENT REMOVAL AND REPLACEMENT

Fuses

All ac line fuses are located on the front panel. All dc protection links and spares are located on the Power Supply board inside the instrument. Remove the 1503 from its case. Remove the aluminum shield from the top of

the unit. The fuses are upright plug-in types located near the center of the instrument (see Fig. 5-1).

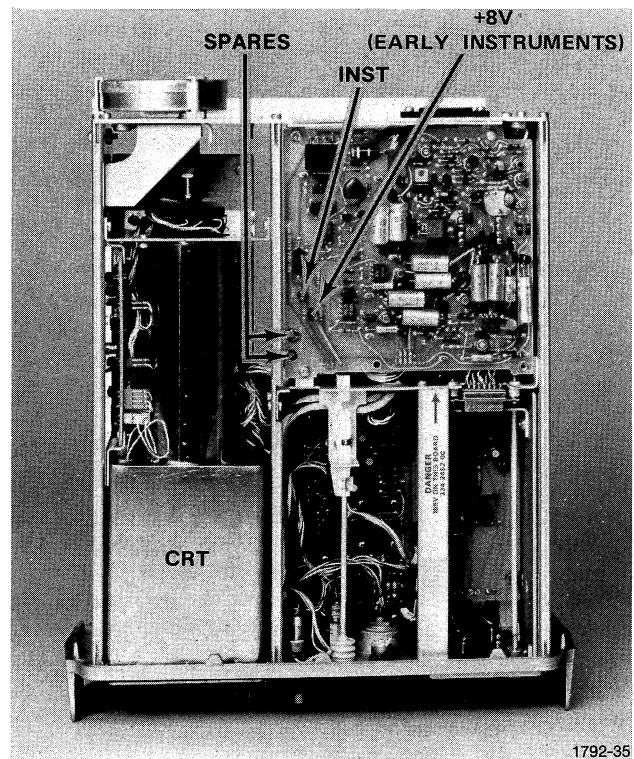

Fig. 5-1. DC protection link location.

Transistor and Integrated Circuits

See Fig. 5-2 for the lead configurations of the transistors and integrated circuits used in the 1503.

Circuit Board Replacement

Most of the components mounted on the circuit boards can be replaced without removing the boards from the instrument. An exception is the HV circuit board which is located underneath the Power Supply board. If a circuit board is damaged beyond repair, the entire assembly (including all soldered-on-components) can be replaced. The number is given in the Electrical Parts List for the completely wired board. Note the position of all plugs and connectors to make replacement easy.

Use the following procedure to remove a circuit board. Follow the inverse procedure to replace boards.

Power Supply Boards

1. Remove the four screws.

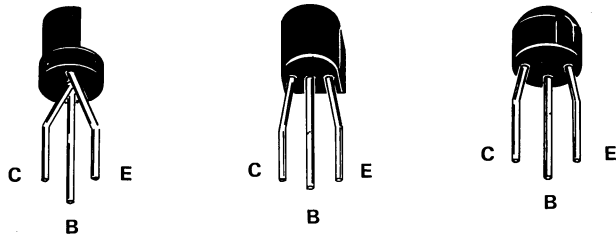

Plastic-Cased Transistors

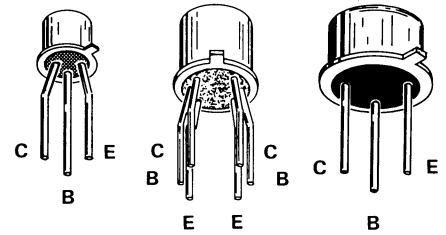

Metal Cased Transistors

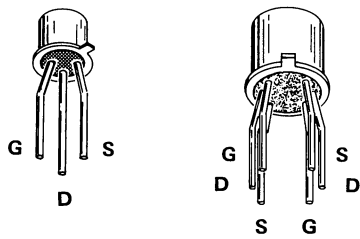

FET's

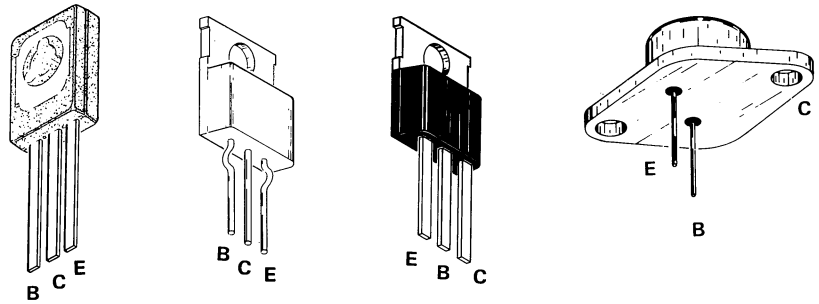

Power Transistors

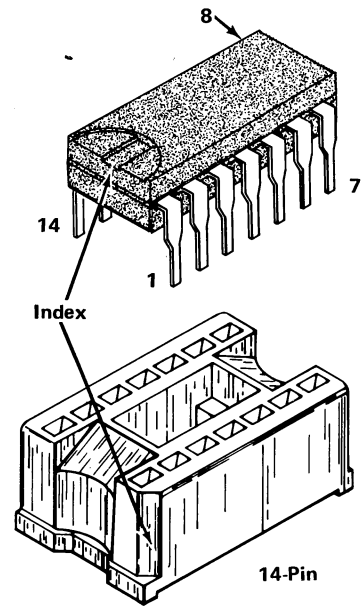
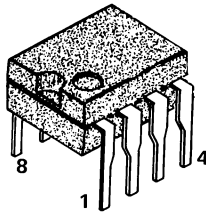
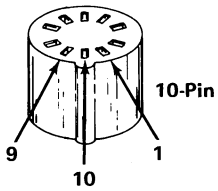
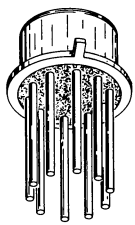

Integrated Circuits

(1206) 1792-36

Fig. 5-2. Transistor and integrated-circuit lead configuration.

Maintenance—1503

2. Remove the pin connectors to P1, P2, and P3 near the rear edge of the board.

3. Carefully lift the rear of the board until the pin connectors underneath come into view.

4. Remove the pin connectors from the bottom of the board and lift it out of the chassis.

HV Board

1. Remove the Power Supply board following the previous procedure.

DANGER

2 kV may be present on the HV Board from charged capacitors.

2. Discharge the possible 2 kV potential by placing a short between point A, Fig. 5-3 and ground. This point is accessible by removing the Battery Pack and turning the 1503 upside down.

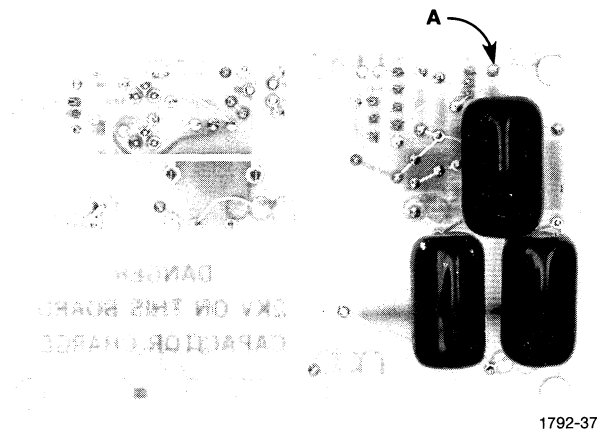

1792-37

Fig. 5-3. Rear view of the HV board.

3. Remove the pin connectors.

4. Remove the four screws holding the board in the chassis.

5. Lift the HV board out of the chassis.

Power Cord Conductor Identification

Conductor	Color	Alternate Color
Ungrounded (Line)	Brown	Black
Grounded (Neutral)	Blue	White
Grounding (Earthing)	Green-Yellow	Green-Yellow

Power Transformer

1. Remove the Power Supply and the HV boards from the chassis using the previous procedures.

2. Unsolder the two leads on the bottom of the Power Transformer.

3. Remove the four bolts holding the transformer in place. The ground wire and lug on the bottom will come off when the bolt and nut are removed.

4. Lift the Power Transformer out of the chassis.

Output Amplifier Board

1. Remove the four pin connectors from the top of the Output Amps board.

2. Remove the four screws holding the board in the chassis.

3. Lift the board out of the hole in the side of the chassis.

Logic Board

1. Remove the three pin connectors from the Logic board.

2. Remove the four screws holding it in the chassis.

3. CAREFULLY lift on the rear of the Logic board to pull the board off the ten feed-thru pins which are mounted on the chassis. Lift the board off the chassis when clear of the pins.

4. Use care when replacing the board to prevent bending the pins or the pin connectors on the board.

Vertical Amp/Slow Ramp Board

Removal of the main board and the Vertical Amp/Slow Ramp board requires removal of some front panel controls. This will destroy the water-tight seals, and special techniques are required to replace the components and preserve the seals. The removal of these boards should be done at a Factory Service Center.

Cathode-Ray Tube Replacement

To replace the crt, proceed as follows:

WARNING

Use care when handling a crt. Protective clothing and safety glasses should be worn. Avoid striking it on any object which might cause it to crack or implode. When storing a crt, place it in a protective carton or set it face down in a protected location on a smooth surface with a soft mat under the faceplate to protect it from scratches.

1. Remove the Battery Pack from the 1503.
2. Remove the pin connectors from the top of the Output Amps board.
3. Remove the four screws holding the crt socket bracket to the frame.
4. Remove the screw bracing the rear of the crt socket.
5. Slide the entire assembly (crt, socket, bracket, and crt shield) to the rear about 1/4 inch. Lift straight up on the entire assembly, clearing the tabs on the front panel casting.
6. Set the assembly on top of the 1503 with the socket wiring still attached.
7. Remove the rubber gasket from around the crt face.
8. Unplug the socket from the crt.
9. Carefully remove the crt from the shield, guiding the two-wire pin connector through the hole in the shield as the crt comes out the front.
10. The Trace Rotation Yoke (L0234) can now be removed and installed on the new crt. Position of the Yoke

is not critical. Make sure it is tight against the neck of the crt and fastened with tape.

11. Install the crt reversing the above procedure. Use care when tightening the screw bracing the crt from the rear of the chassis.

230/115 Volt Line Selector. The line selector is composed of the input transformer's terminals and can be wired for either 115 V or 230 V. It is factory wired for 115 V. If 230 V operation is required, remove the wire straps from lugs 1-2 and 3-4 of T0389 then connect a strap from lug 2 to lug 3. See Fig. 5-4.

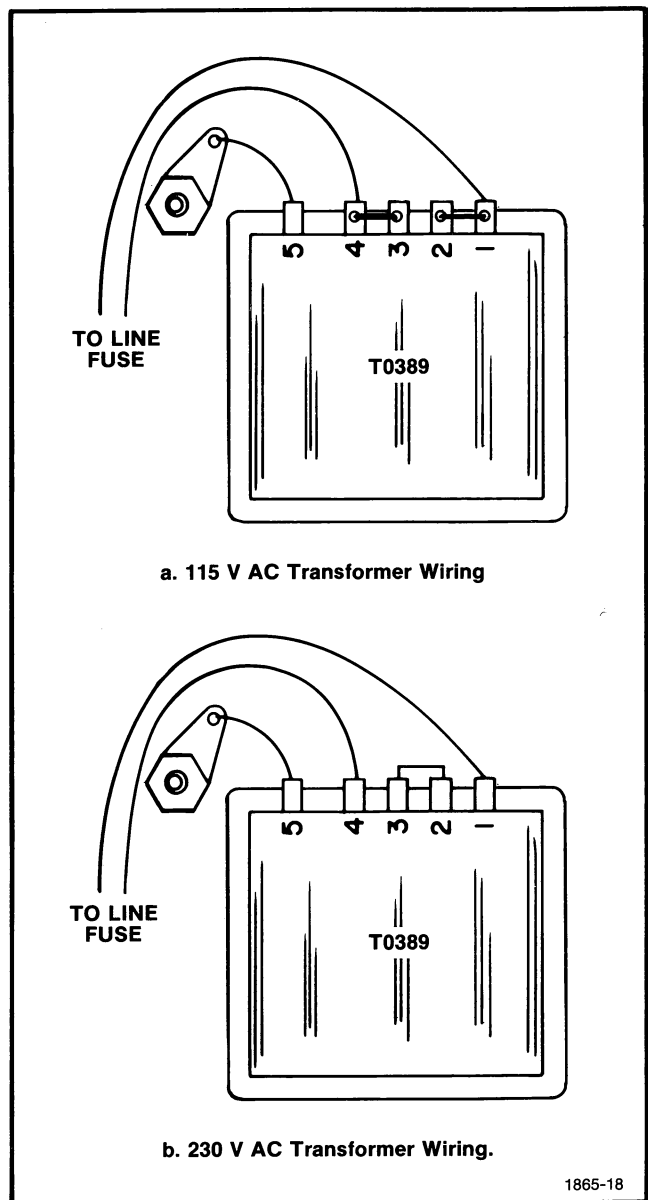

Fig. 5-4. Power transformer wiring.

CAUTION

If the instrument is wired for 230 V operation, be sure that the two front panel fuses are changed to the proper slow-blow fuses described in the parts list.

Water-tight Seals

The 1503 may be operated in any weather (rain, snow, dust, etc.). To prevent moisture and dust from getting inside the instrument, special seals are used around the pushbuttons, crt, power switches, and rotary controls. Removal of any of the components on the front panel will require special resealing procedures to retain their water-tight integrity. We recommend that the instrument be returned to a Tektronix Factory Service Center to have this resealing done, if water-tight resealing is required. Sealing instructions are included in this section, however.

The gaskets installed in the slots around the front panel casting where the case and front cover fit, should be

replaced at regular intervals (six to eight months depending on locality and use).

In order to maintain the water-tight integrity of the 1503, it is important to visually inspect the water-tight seals periodically. Seals around the X-Y Output Module, the battery pack and the front cover seal on the front panel should be checked regularly to see that they have not become damaged. The clam shell seal on the back of the front-panel casting and the seals around the front-panel controls and connectors should be inspected when the cabinet has been removed for maintenance, calibration purposes, or if a leak is suspected.

CAUTION

Anytime the cabinet has been removed from the 1503 or when any front panel controls or connectors have been removed from the front panel, the water-tight integrity of the 1503 will be jeopardized.

RESEALING PROCEDURES

MATERIALS REQUIRED

Tektronix Part No.	Description	Notes
006-2302-00	Dow Corning No. 3144 Adhesive Sealant	This Room Temperature Vulcanizing agent (RTV) is used to form watertight gaskets. (After application, allow 24 hours curing time.)
252-0199-00	Dow Corning No. 3140 Coating	This RTV agent is used where the application requires a sealant more fluid than the No. 3144 sealant. (Allow 24 hour curing time.)
006-0315-00	Dow Corning No. 4 Silicone Dielectric Compound	This compound is used in the Battery Pack assembly.
006-2475-00	Dow Corning No. 1204 Primer	Used as a primer for No. 3144 sealant applications.
006-2207-00	General Electric No. G-661 Silicone grease	Used as a waterproof lubricant.
006-0500-00	Acetone	Cleaning Agent.
006-0034-00	Isopropyl Alcohol	Cleaning Agent.

ASSEMBLY PROCEDURES

NOTE

In the following assembly steps, the part being discussed is identified by its location in the Replaceable Mechanical Parts list (MPL) of the Instruction Manual.

1. Preparation of the Subpanel for further assembly (see Fig. 5-5)

- a. SUBPANEL, FRONT
MPL Item 3-26.
- b. Procedure
 1. Clean entire Subpanel with isopropyl alcohol.

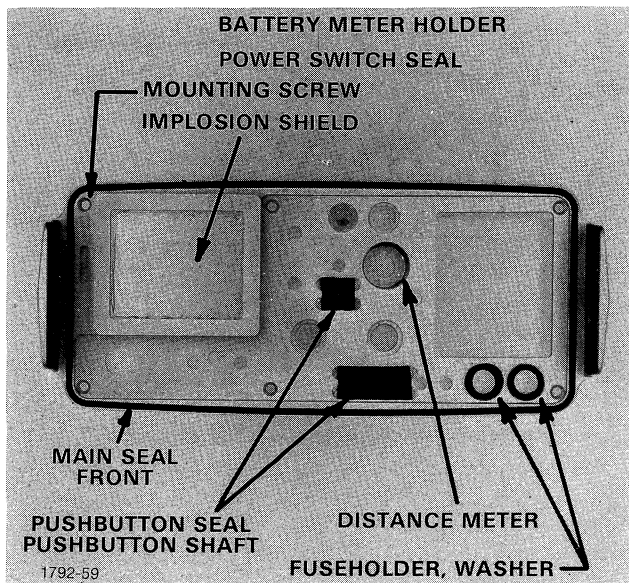

Fig. 5-5 Subpanel, identification of parts for steps 1 through 7.

2. Install the Holder for the Battery Level Indicator in the Subpanel

- a. HOLDER
MPL Item 2-57.
- b. Procedure
 1. Insert the holder into the Subpanel.
 2. This item does not require the application of a sealing compound.

3. Install the seal for the Power Switch in the Subpanel

- a. SEAL, SWITCH
MPL Item 2-55.
- b. Procedure
 1. Clean mating surface of seal with acetone.
 2. Coat mating surface of seal with No. 3144 sealant.
 3. Install seal in Subpanel.

4. Install washers for the Fuseholders in the Subpanel

- a. WASHER, FLAT (2 ea.)
MPL Item 2-51.
- b. Procedure
 1. Clean the washers with acetone.
 2. Coat the mating surfaces of the washers with No. 3144 sealant.
 3. Insert the washers in the Subpanel.

5. Install the Pushbutton seals in the Subpanel

- a. SEAL, PUSHBUTTON
MPL Item 2-53, MPL Item 2-54, and MPL Item 2-52.
- b. Procedure
 1. Clean mating surfaces of seals with acetone.
 2. Coat mating surfaces with No. 3144 Sealant.
 3. Install seals in subpanel.

6. Installation of rubber seals in two grooves located on the outer (see Figs. 5-5 and 5-6) edges of the front and rear sides of the Subpanel

- a. SEAL, RUBBER (2 ea.)
MPL Item 2-58.

b. Procedure

1. Clean the rubber seals with acetone.

2. Apply a film of No. 3140 sealant to the inner surface of each groove. See Fig. 5-6. Do not apply the sealant to the other surfaces of the grooves. No. 3140 is more fluid than No. 3144 and can be applied with a hypodermic type applicator.

3. Place a seal in each groove. Trim each seal to a length such that its ends butt together. Apply a film of No. 3140 sealant to the butt joint.

4. Before installing the instrument in a cabinet, lubricate the outer edges of the seals as shown in Fig. 5-6.

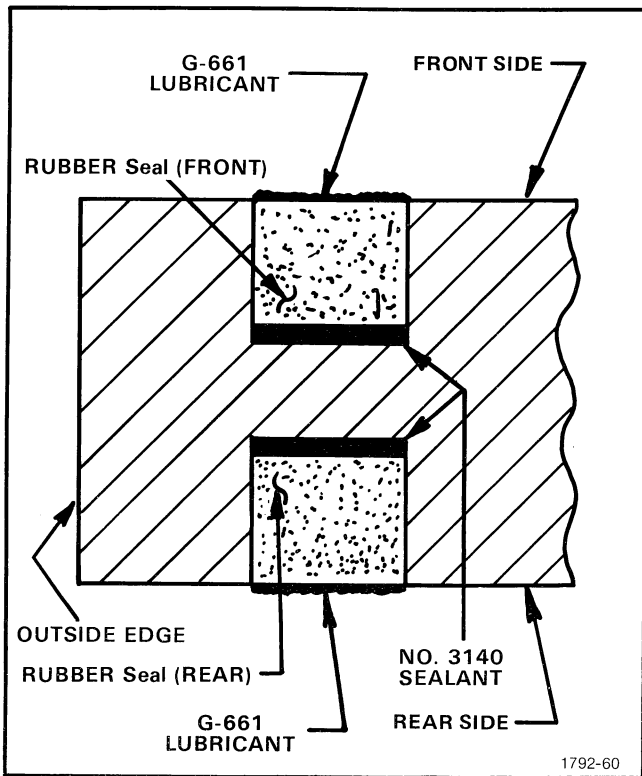

Fig. 5-6. Rubber Seals, edge sealing for subpanel.

7. Install the implosion shield and its retainer on the Subpanel (see Figs. 5-5 and 5-7)

- a. SHIELD, IMPLOSION
MPL Item 2-91.

- b. RETAINER
MPL Item 2-90.

c. Procedure

1. Clean the retainer and the implosion shield mounting area of the Subpanel with acetone.

2. Remove the protective paper from the implosion shield.

3. Position the shield on the Subpanel and form a continuous bead of No. 3144 sealant, approximately .090 inch in diameter, around the shield/Subpanel interface.

4. Position the retainer over the bead of sealant and press into place.

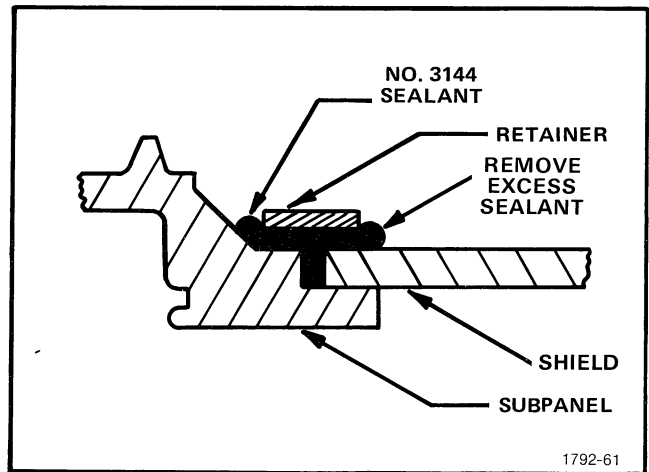

Fig. 5-7. Detail of implosion shield sealing.

NOTE

1. Pressing the retainer should cause some of the sealant to appear outside the retainer area, see Fig. 5-7. Failure of the sealant to appear at any point around the retainer is an indication of inadequate sealing.

2. When performing this step, assure that the shield makes flush contact with the subpanel, see Fig. 5-7.

5. After a curing time of approximately 4 hours, use a small wooden dowel, such as a Q-tip handle, and remove the excess sealant that is visible between the shield and retainer.

8. Preparation of Front Panel for assembly (see Fig. 5-8)

a. FRONT PANEL

MPL Item 2-49 and (Option 5) MPL Item 2-49.

b. Procedure

1. Clean mating surface of front panel with acetone.
2. Coat mating surface of panel with No. 1204 primer. Allow 2 hour curing time.

2. Apply No. 3144 sealant to mating surface of seal.
3. Position seal on rear side of Front Panel.
4. Allow 2 hour curing time. Inspect seal bond, and remove any excess sealant. Allow an additional 22 hour curing time.

NOTE

Be sure seal is bonded securely to edge of panel as well as rear surface of panel.

9. Bonding of Plug-in Compartment seal to Front Panel (see Fig. 5-9)

a. SEAL, PLUG-IN

MPL Item 2-50.

b. Procedure

1. Clean mating surfaces of seal with acetone.

10. Bonding of washer to BNC type connector that is located on the Main Circuit Board Assembly (see Fig. 5-10)

a. CONNECTOR, RECEPTACLE

MPL Item 2-170.

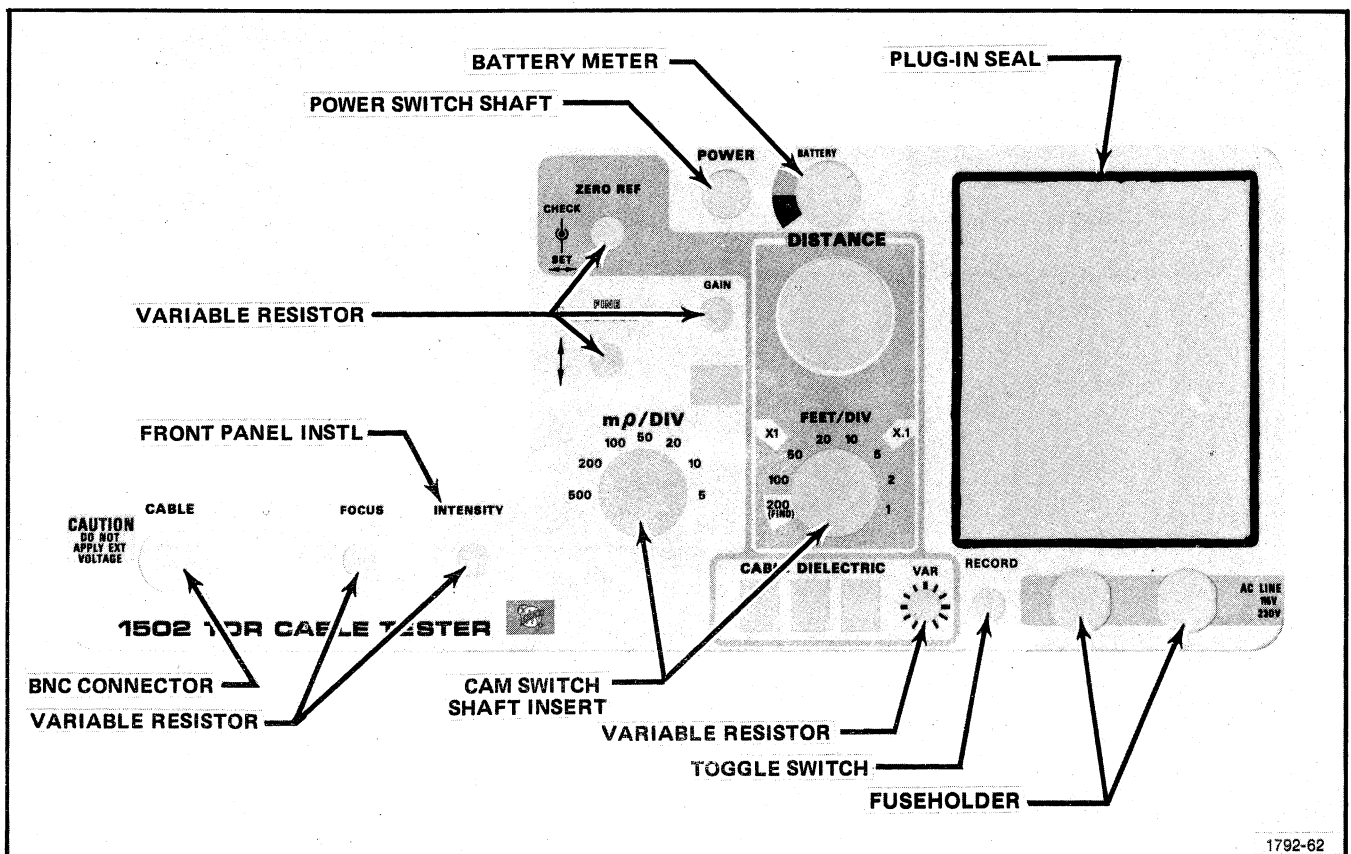

Fig. 5-8. Front Panel, identification of parts for assembly steps 8 through 26.

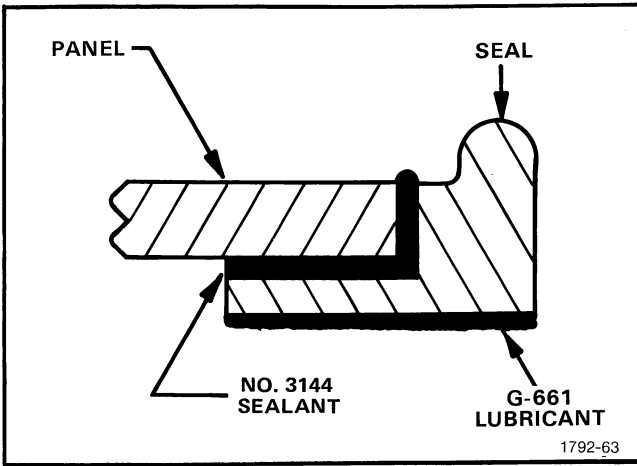

Fig. 5-9. Detail of Plug-In Compartment seal.

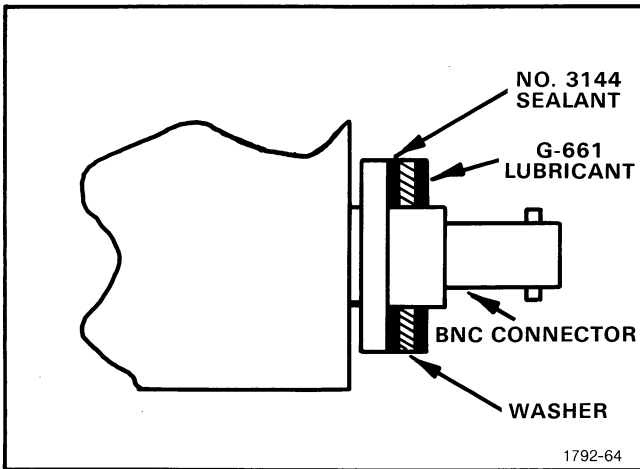

Fig. 5-10. Detail of BNC Connector and Washer.

- b. WASHER, FLAT SPONGE
MPL Item 2-94.

c. Procedure

1. Clean mating surfaces of BNC Connector and Washer with acetone. Allow to dry.

2. Apply No. 1204 Primer to mating surface of BNC connector. Allow 2 hour curing time.

3. Coat mating surface of washer with No. 3144 sealant.

4. Assemble washer on BNC connector.

11. Install pushbuttons and their shaft assemblies (see Fig. 5-11)

a. PUSHBUTTONS

MPL Item 2-7, MPL Item 2-8, MPL Item 2-9, MPL Item 2-10, MPL Item 2-11, MPL Item 2-12, MPL Item 2-13, and MPL Item 2-14.

b. EXTENSION SHAFT

MPL Item 2-97 (8 ea.).

c. Procedure

1. Clean the mating surfaces of each shaft with isopropyl alcohol.

2. Insert the shafts into the pushbutton seals. See Fig. 5-11.

3. Apply bead of No. 3144 sealant to each shaft/seal interface.

4. Install pushbuttons in their respective locations.

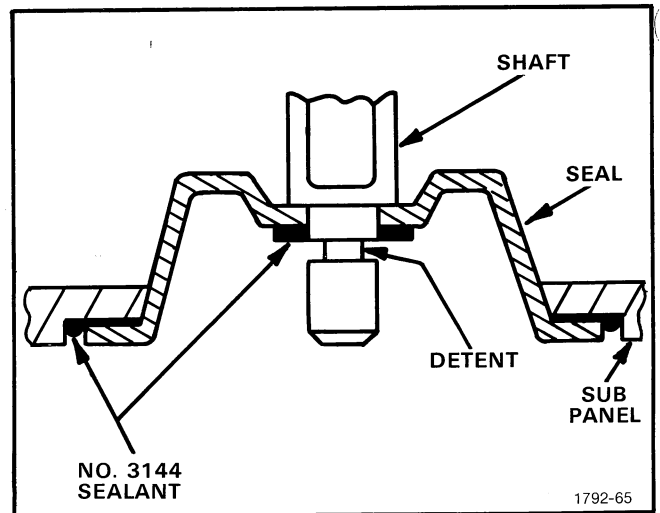

Fig. 5-11. Detail of Pushbuttons and their Shafts.

12. Attach Subpanel to the three Frame Sections (see Fig. 5-12)

a. FRAME SECTIONS

Left, MPL Item 3-115; Center, MPL Item 3-116; Right, MPL Item 3-117.

b. SCREWS

1. MPL Item 3-27 (1 ea.), MPL item 3-28 (5 ea.).

c. Procedure

1. Fill the countersunk screw holes on the Subpanel with No. 3144 sealant. See Fig. 5-12.

2. Attach the Subpanel to the three Frame sections. The decorative screw is installed in the upper-left corner of the subpanel.

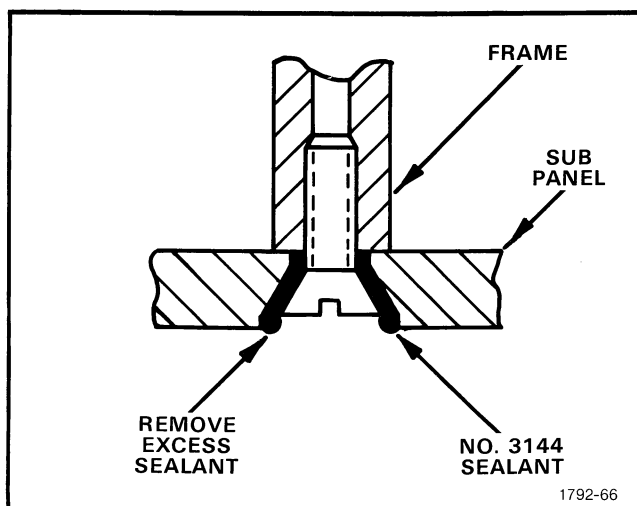

Fig. 5-12. Detail of Subpanel screwhole sealing.

13. Install Front Panel on Subpanel

a. Procedure

1. Apply G-661 lubricant to the rear surface of the Plug-in Seal, and to the two Fuse Holder Seals.

2. Place Front Panel on the Subpanel.

14. Install Fuseholders in Front Panel (see Fig. 5-13)

a. FUSEHOLDERS

MPL Item 2-26.

b. Procedure

1. Install the two Fuseholders as shown in Fig. 5-13.
2. Tighten the retaining nut on the fuseholder until the Front Panel is pulled flush with the Subpanel.



Do not overtighten.

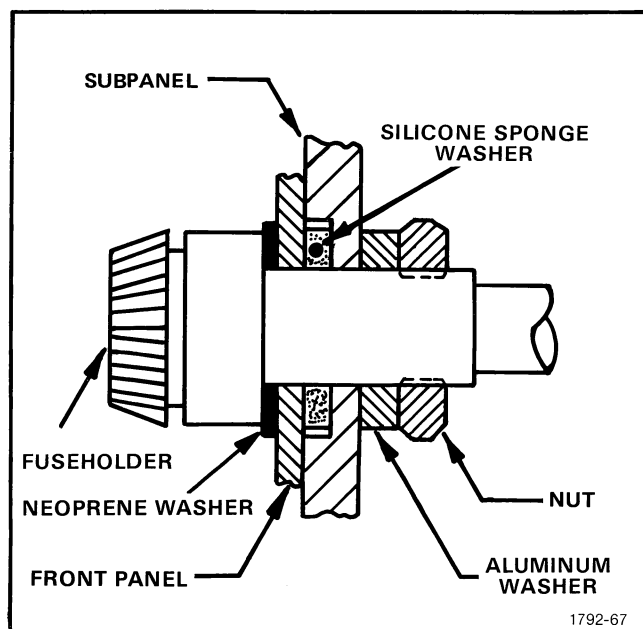

Fig. 5-13. Detail of Fuseholder installation.

15. Install Fuseholder Caps (see Fig. 5-14)

a. WASHERS

MPL Item 2-27.

b. Procedure

1. Clean washers and Fuseholder Caps with isopropyl alcohol.

2. Apply No. 3144 sealant to one surface of a washer and place the washer in one of the Fuseholder Caps. Repeat for the other washer and cap.

3. Insert the caps in the Fuseholders and press to ensure the washers are fully seated.

4. Remove the caps, inspect, and remove any excess sealant.

5. Apply a film of G-661 lubricant to exposed surface of washer.

6. Insert fuse (see Electrical Parts list for correct value) into cap and install cap with fuse in the Fuseholder.

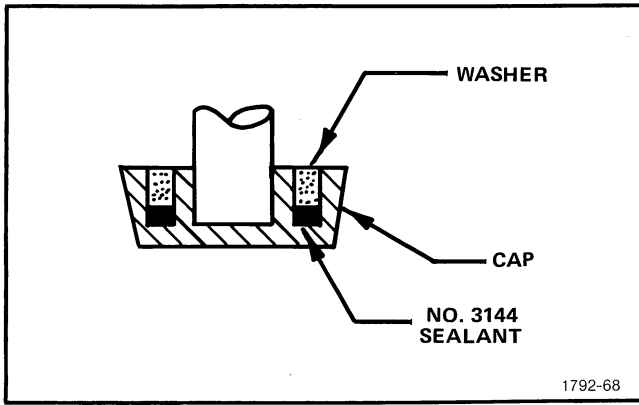

Fig. 5-14. Detail of Fuseholder Caps.

16. Install Battery Meter (see Fig. 5-15 and 5-16)

a. METER

MPL Item 2-56.

b. Procedure

1. Apply a thin bead of No. 3144 sealant to the junction of the bezel and meter canister (see Fig. 5-15).

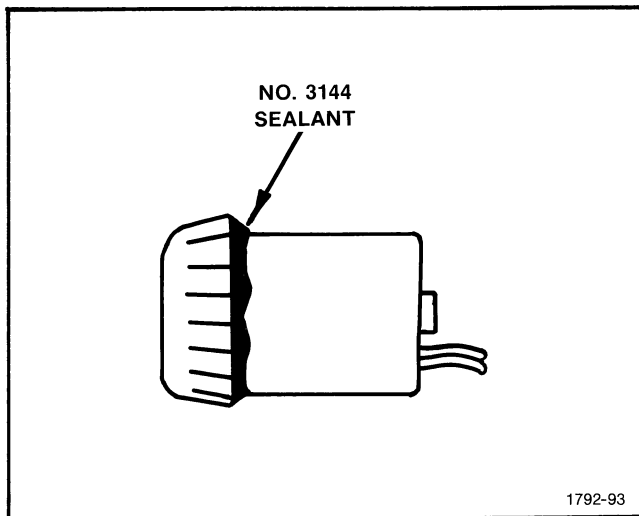

Fig. 5-15. Application of sealant to Battery Meter.

2. Install Meter in Front Panel with markings aligned as shown in Fig. 5-16.

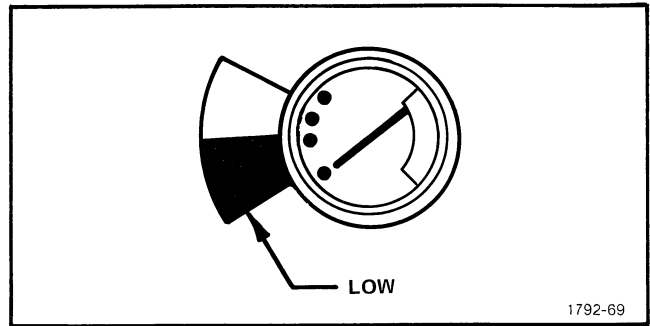

Fig. 5-16. Alignment of Battery Meter.

17. Install the FOCUS and INTENSITY controls (see Fig. 5-17)

a. RESISTOR, VARIABLE (2 ea.)

MPL Item 2-40 and Item 2-43.

These two variable resistors are used for FOCUS and INTENSITY control and are listed in the Electrical Parts list.

b. Procedure

1. Unscrew the bushing part of the resistor assembly and pack the barrel/shaft interface with G-661 lubricant.
2. Screw the bushing into the resistor assembly.
3. Form a bead of No. 3144 sealant around the fillet area of the bushing.
4. Use the washers and nuts supplied and install these two controls in the Front Panel.

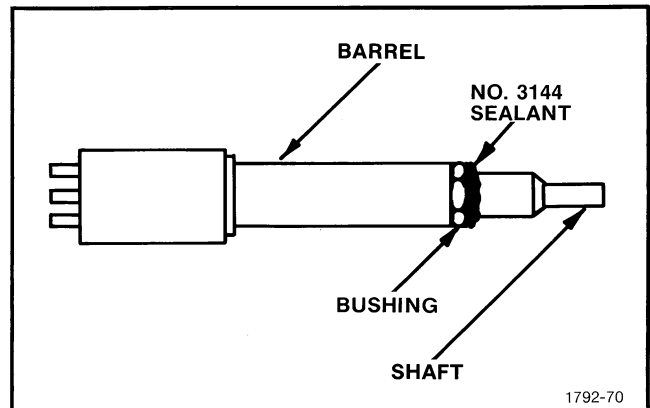

Fig. 5-17. Application of sealant to FOCUS and INTENSITY controls.

18. Install FINE POSITION control (see Fig. 5-18 and 5-19)

a. RESISTOR, VARIABLE

MPL Item 2-32.

The part number for this variable resistor is listed in the Electrical Parts list.

b. Procedure

1. Form a bead of No. 3144 sealant around the bushing threads as shown in Fig. 5-18.

2. Install nut on bushing as shown in Fig. 5-19.

3. Form a bead of No. 3144 sealant at the interface of the nut and bushing as shown in Fig. 5-19.

4. Use washer and nut supplied and install the control in the Front Panel.

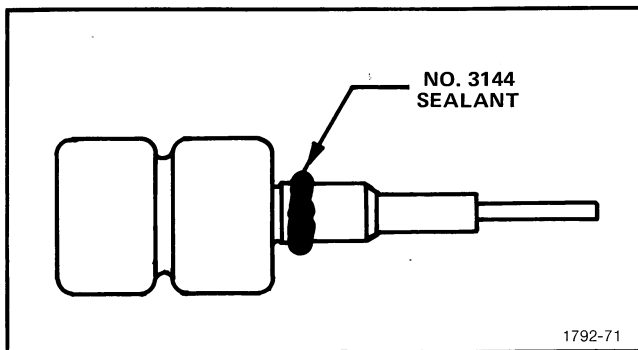

Fig. 5-18. Application of sealant to FINE control bushing.

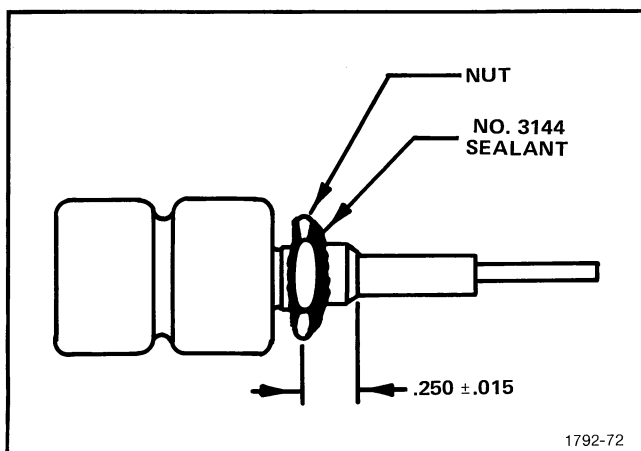

Fig. 5-19. Application of sealant to FINE control nut.

19. Install the DISTANCE METER in the Front Panel (see Fig. 5-20)

a. RESISTOR, VARIABLE

MPL Item 2-46.

This variable resistor is listed in the Electrical Parts list as the Distance Meter.

b. Procedure

1. Insert the resistor assembly in the Front Panel.

2. Form a bead of No. 3144 sealant at the interface of the resistor assembly and the Front Panel. The bead should include the threads and anti-rotation lug.

3. Use the flat-washer, lock-washer, and nut to secure the resistor assembly to the Front Panel.

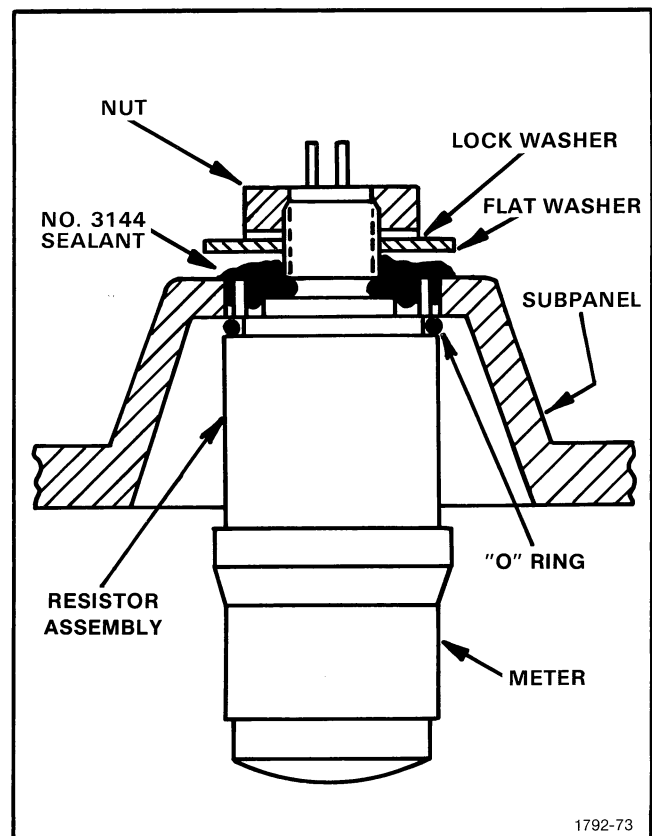

Fig. 5-20. Installation of Distance Meter.

20. Install the ZERO REFERENCE control in the Front Panel (see Figs. 5-21 and 5-22)

a. RESISTOR, VARIABLE

MPL Item 2-49.

This variable resistor is listed in the Electrical Parts list.

b. Procedure

1. Form a bead of No. 3144 sealant around the threads of the bushing as shown in Fig. 5-21.

2. Flatten or remove the anti-rotation lug on the resistor housing.

3. Install nut as shown in Fig. 5-22.

4. Form a bead of No. 3144 sealant around the nut/bushing interface.

5. Use attaching hardware and install resistor in Front Panel.

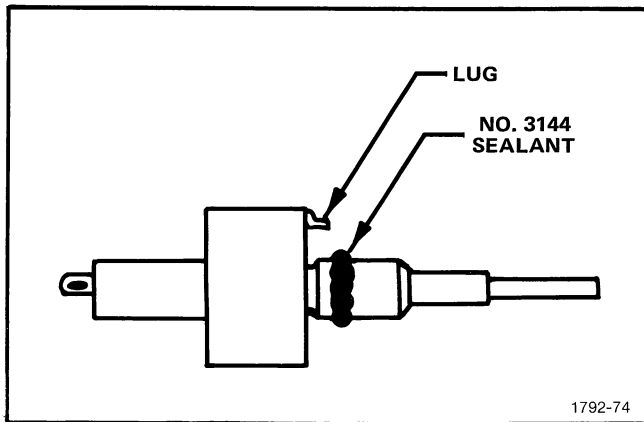

Fig. 5-21. Application of sealant to ZERO REFERENCE control bushing.

21. Install the Record control (see Figs. 5-23, 5-24, 5-25)

a. SWITCH, TOGGLE

MPL Item 2-23.

b. CAP, TOGGLE SWITCH, SEAL

MPL Item 2-24.

c. Procedure

1. Form a bead of No. 3144 sealant around the bushing/switch body interface as shown in Fig. 5-23.

2. Install nut that was supplied with the switch, as shown in Fig. 5-24.

3. Form a bead of No. 3144 sealant around the bushing/nut interface as shown in Fig. 5-24.

4. Use attaching hardware and install the toggle switch in the Front Panel.

5. Install the cap-seal on the toggle switch (see Fig. 5-25).

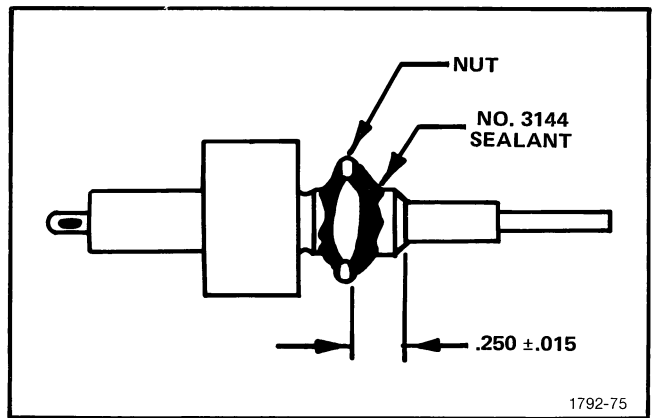

Fig. 5-22. Application of sealant to ZERO REFERENCE control nut.

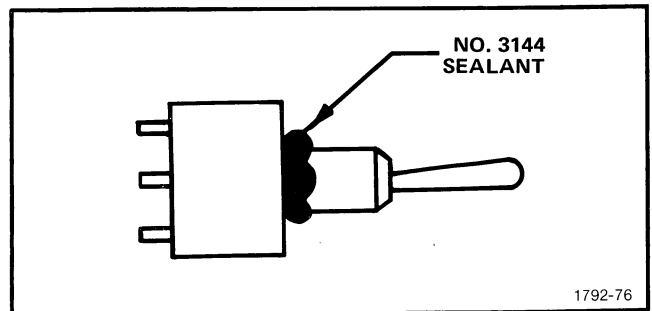

Fig. 5-23. Application of sealant to RECORD toggle-switch bushing.

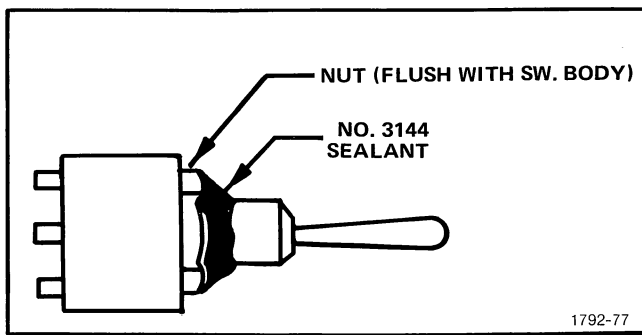

Fig. 5-24. Application of sealant to RECORD toggle-switch nut.

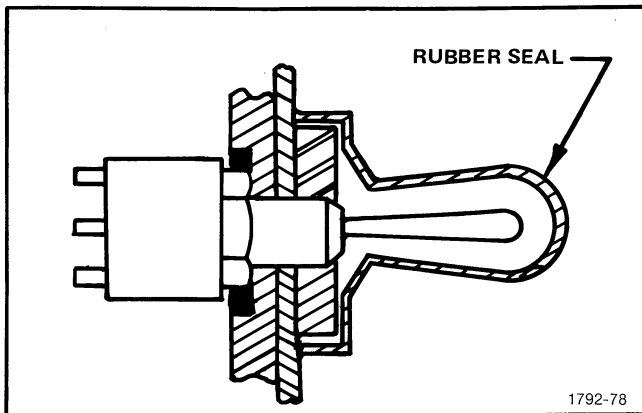

Fig. 5-25. Installation of rubber Cap-Seal on RECORD toggle-switch.

22. Install the VAR control and the 0-dB SET control (see Figs. 5-26 and 5-27)

a. RESISTOR, VARIABLE

MPL Item 2-19 (VAR control), MPL Item 2-35 (0-dB SET control).

b. Procedure

1. Partially unscrew Hex spacer nut and form a bead of No. 3144 sealant around the bushing threads as shown in Fig. 5-26.
2. Re-tighten the Hex spacer nut.
3. Pack the Shaft/Threaded Bushing interface with G-661 lubricant as shown in Fig. 5-27.
4. Form a bead of No. 3144 sealant on the end of the Hex space nut as shown in Fig. 5-27.
5. Install the resistor in the Front Panel.

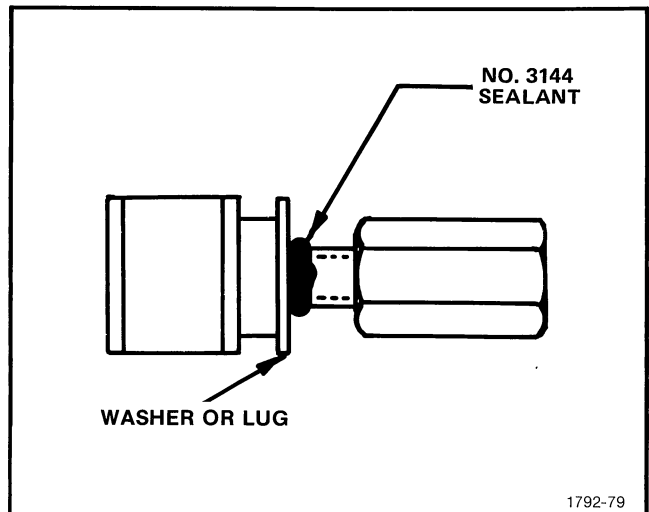

Fig. 5-26. Application of sealant to the 0-dB SET control bushing.

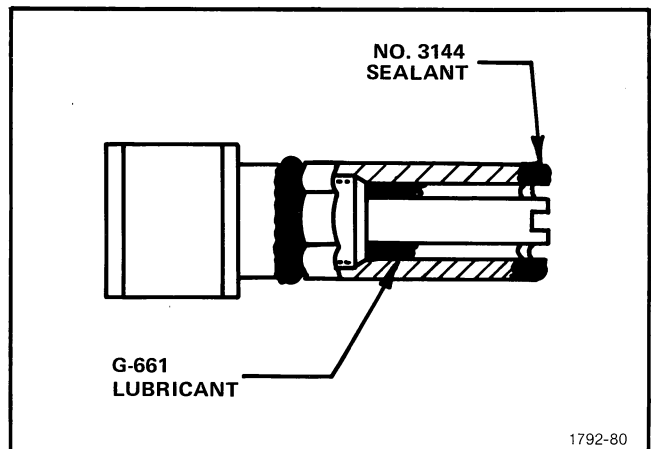

Fig. 5-27. Detail showing lubrication and sealing for the variable resistor.

23. Partial installation procedure for Main Circuit Board Assembly

a. MAIN CIRCUIT BOARD ASSY.

Not shown in MPL as separate item.

b. Procedure

1. Lubricate washer on BNC connector with G-661 lubricant.
2. Insert Main Circuit Board Assembly into instrument chassis engaging pushbutton shafts with their respective switches. (Take care not to damage pushbutton seals.)

3. Do not install Main Circuit Board holding screws at this point.

24. Install cam switch inserts (see Fig. 5-28)

- a. INSERT, SHAFT SEAL (2 ea.)
MPL Item 2-100.
- b. PACKING (O-ring, 2 ea.)
MPL Item 2-101.
- c. Procedure
 1. Apply G-661 lubricant to O-ring and install as shown in Fig. 5-28.
 2. Form a bead of No. 3144 sealant around the fillet area of the insert.
 3. Install the two inserts in the Front Panel. Tighten until snug, then back off 2° to 3°. Remove any excess sealant.

25. Finish installation procedure for Main Circuit Board Assembly

- a. Procedure
 1. Install washer and nut on BNC connector. Tighten nut to a torque reading of 20 ± 3 inch-pounds.
 2. Install Main Circuit Board holding screws.

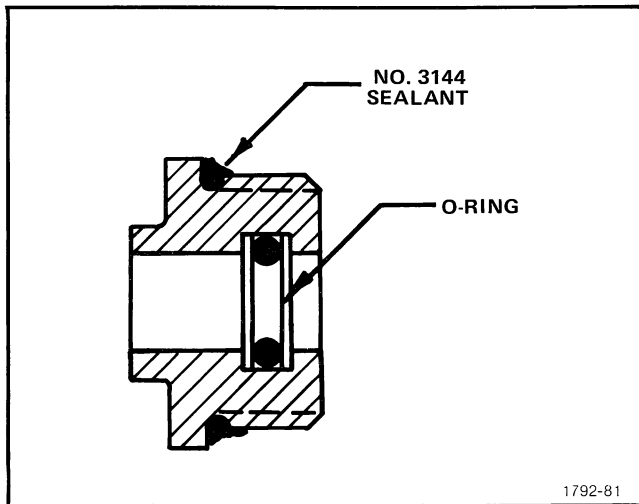

Fig. 5-28. Lubrication of the O-rings and sealing for the cam-switches.

26. Install Power Switch Shaft into Front Panel (see Fig. 5-29)

- a. EXTENSION-SHAFT
MPL Item 2-17.
- b. BUSHING
MPL Item 2-18.
- c. Procedure
 1. Insert the bushing into the Power Switch Seal that was previously installed in the Front Panel.
 2. Apply G-661 lubricant to the detent area of the Power Switch Shaft.
 3. Install as shown in Fig. 5-29.

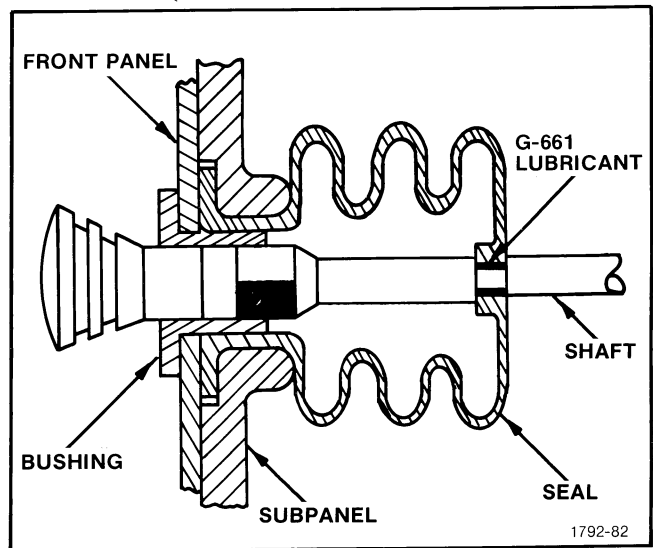

Fig. 5-29. Installation of the POWER switch.

27. Installation of the POSITION knob and the FINE POSITION knob (see Figs. 5-30 and 5-31)

- a. KNOB, POSITION
MPL Item 2-4.
- b. KNOB, FINE POSITION
MPL Item 2-2.
- c. Procedure
 1. Apply G-661 lubricant to the POSITION knob as shown in Fig. 5-30.

2. Assemble the POSITION knob and the FINE POSITION knob on the control shafts as shown in Fig. 5-31.

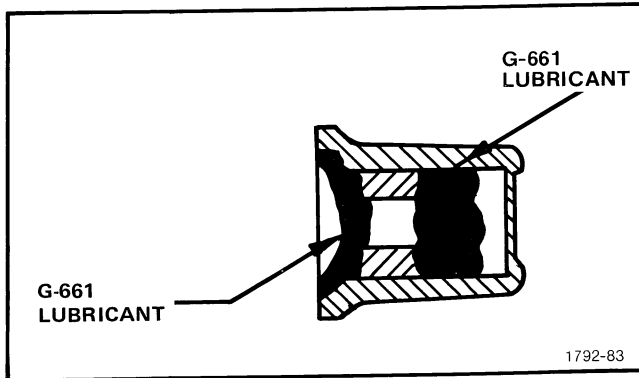

Fig. 5-30. Lubrication of POSITION control knob.

2. Actuate the pushbutton several times. Remove any excess lubricant.

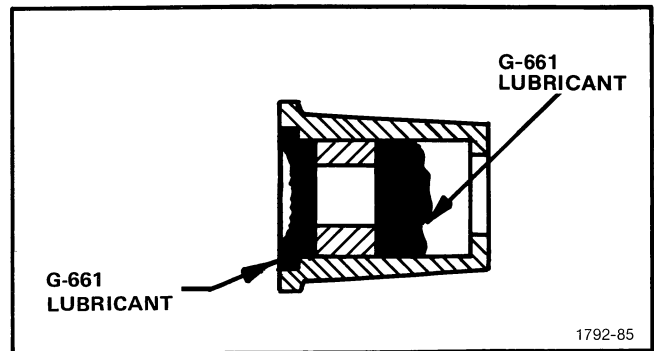

Fig. 5-32. Lubrication of ZERO REFERENCE knob.

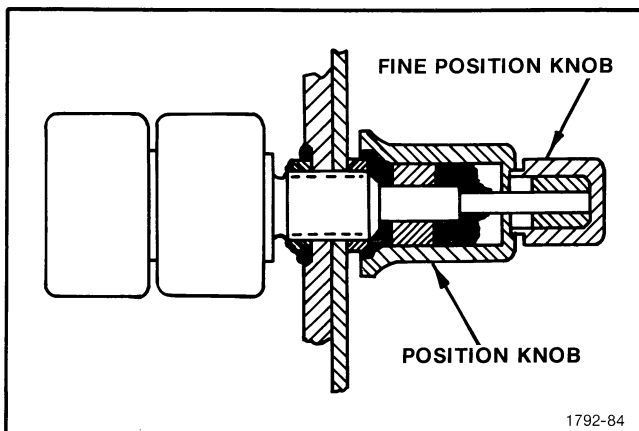

Fig. 5-31. Installation of knob on shaft.

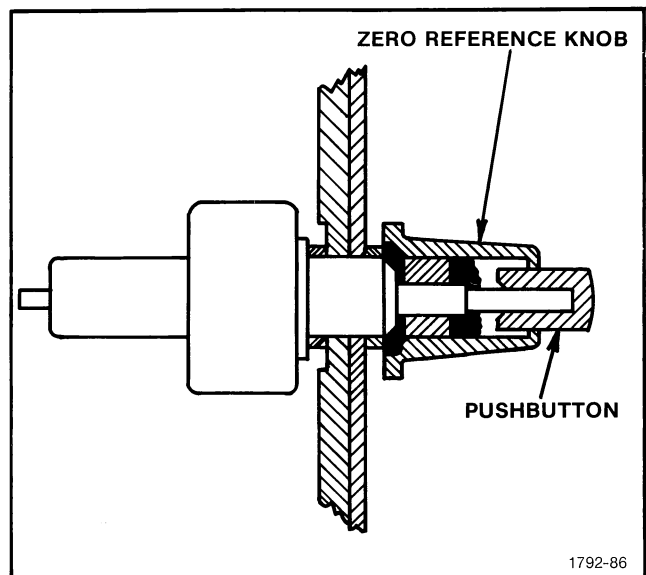

Fig. 5-33. Installation of knob on ZERO REFERENCE control.

28. Installation of the ZERO REFERENCE knob and the zero reference CHECK pushbutton (see Figs. 5-32 and 5-33)

- a. KNOB, ZERO REFERENCE
MPL Item 2-4 (same as FINE POSITION knob).
- b. PUSHBUTTON
MPL Item 2-3.
- c. Procedure
 1. Apply G-661 lubricant to the ZERO REFERENCE knob as shown in Fig. 5-32.
 2. Assemble the knob and pushbutton on the control shafts as shown in Fig. 5-33.

29. Install the FOCUS and INTENSITY knobs (see Fig. 5-34)

- a. KNOB, 2 ea.
MPL Item 2-1.
- b. Procedure
 1. Apply G-661 lubricant to both knobs as shown in Fig. 5-34.
 2. Install the knobs on the shafts of the FOCUS and INTENSITY controls.

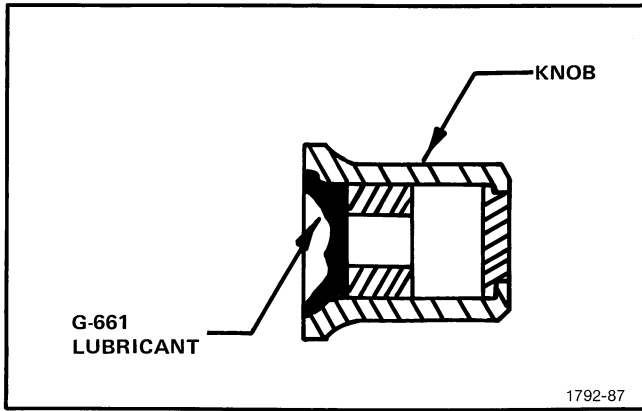

Fig. 5-34. Lubrication of FOCUS and INTENSITY control knobs.

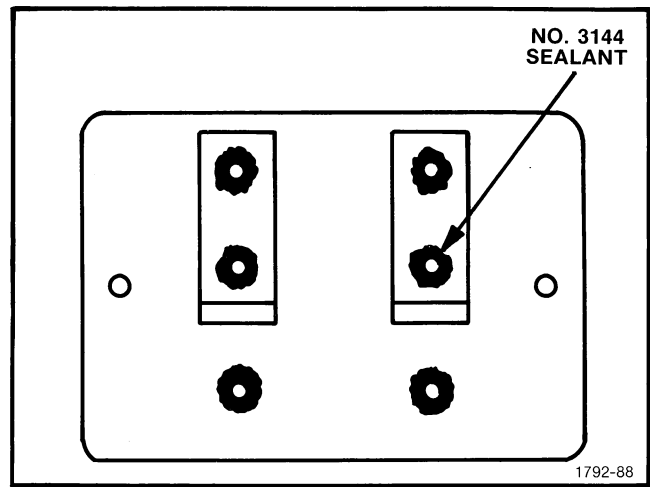

Fig. 5-35. Sealing of Battery Pack screwholes.

30. Watertight sealing procedures for the Battery Pack (see Figs. 5-35 and 5-36)

- a. BATTERY PACK
MPL Item 2-30.
- b. PANEL
Not shown in MPL.
- c. HEAT SINKS
Not shown in MPL.
- d. GASKET
Not shown in MPL.
- e. Procedure

1. Clean Panel with isopropyl alcohol.
2. Form a bead of No. 3144 sealant in and around each of the six screw holes in the Panel. See Fig. 5-35.
3. Apply a film of Dow Corning No. 4. Compound to the mating surfaces of the heat sinks and the Panel and join as shown in Fig. 5-36.
4. Clean the gasket with acetone.
5. Apply a film of No. 3144 sealant to the gasket and attach it to the Panel as shown in Fig. 5-36.

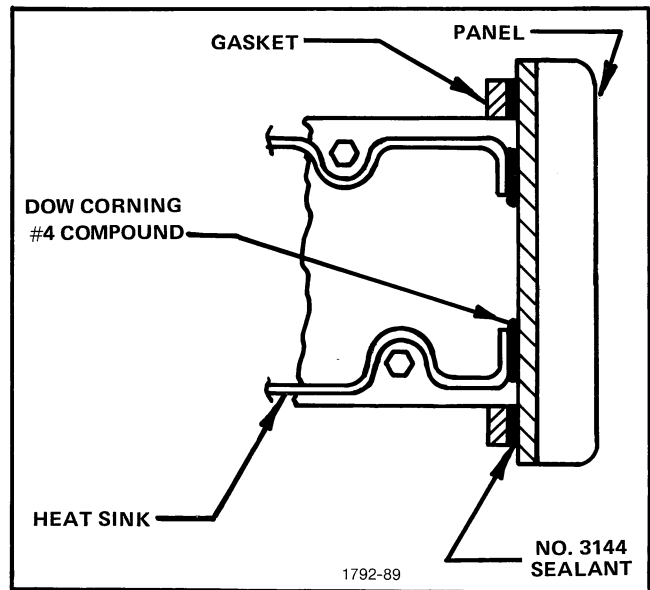

Fig. 5-36. Application of dielectric type compound.

31. Watertight sealing procedures for the Front Panel jacks of the X-Y Output Module, 016-0606-00, (see Fig. 5-37)

- a. FRONT PANEL
MPL Item 3-13.
- b. SUB PANEL
MPL Item 3-14.
- c. JACK, TIP: BLACK
MPL Item 3-5.

- d. JACK, TIP: RED
MPL Item 3-6.

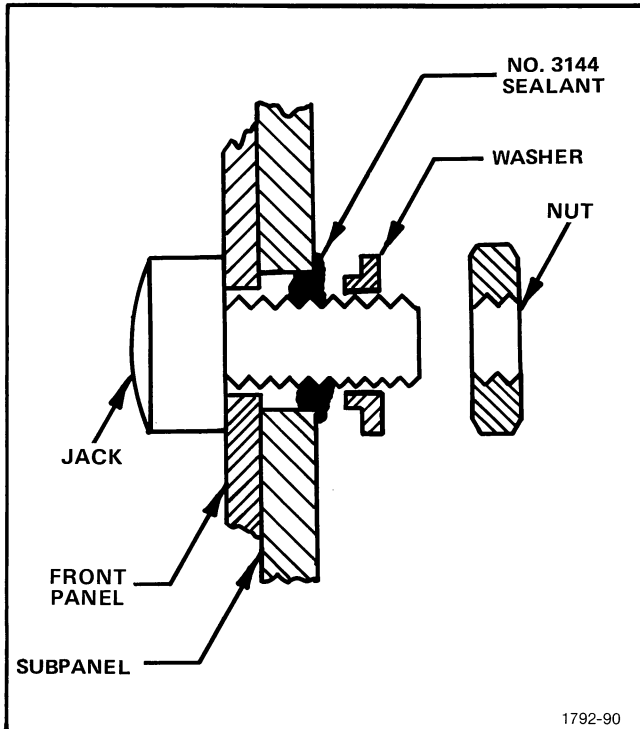

Fig. 5-37. Detail of front-panel jacks.

- e. Procedure
 1. Clean the mating surface of the Subpanel with isopropyl alcohol.
 2. Align the Front Panel over the Subpanel and insert one of the jacks in its respective position.
 3. Form a bead of No. 3144 Sealant around the Jack/Subpanel interface as shown in Fig. 5-37.
 4. Use the supplied washer and nut to secure the jack in position.
 5. Repeat Steps 3 and 4 for the remaining five jacks.

32. Preparation of the Thumbscrews that are used for securing the X-Y Output Module (see Fig. 5-38)

- a. PACKING (O-ring)
MPL Item 3-10.

- b. PIN, (shaft)
MPL Item 3-8.

- c. KNOB
MPL Item 3-7.

- d. Procedure
 1. Insert one of the Pins (shaft) through the Front Panel and Subpanel.
 2. Apply G-661 lubricant to the O-ring.
 3. Position the O-ring on the shaft as shown in Fig. 5-38.
 4. Place the knob on the shaft and tighten the setscrew.
 5. Repeat procedure for the second thumbscrew.

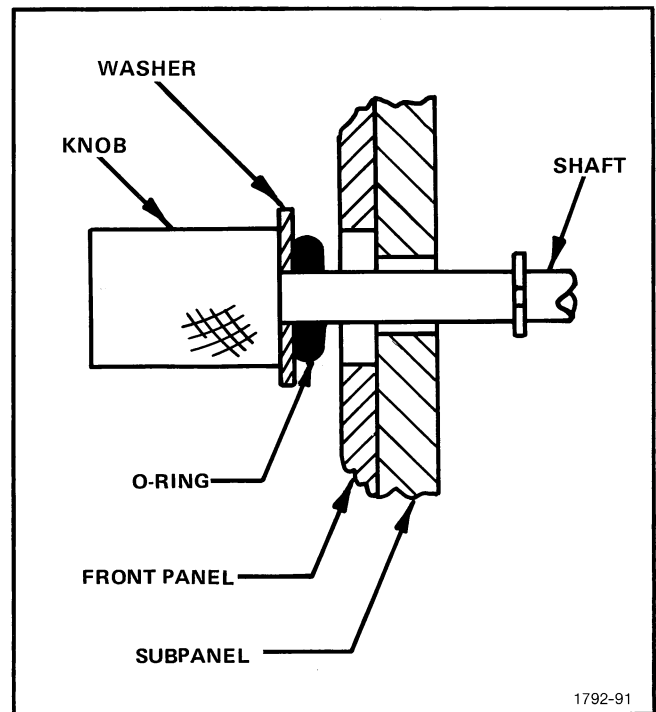

Fig. 5-38. Detail of X-Y Module thumbscrews.

33. Attach Latch Assemblies (2 ea.) to the Front Cover (see Fig. 5-39)

- a. COVER, FRONT
MPL Item 1-29.

- b. LATCH ASSY.
MPL Item 1-0.

- c. Procedure
 1. Clean mating surfaces of Front Cover and Latch Assembly with isopropyl alcohol.

 2. Apply No. 3144 sealant to the two screw-holes in each Latch Assembly as shown in Fig. 5-39.

 3. Attach the two Latch Assemblies to the Front Cover.

REMINDER: Don't forget to lubricate surface of rubber seals around edge of subpanel with G-661 lubricant before installing instrument in cabinet and attaching front cover.

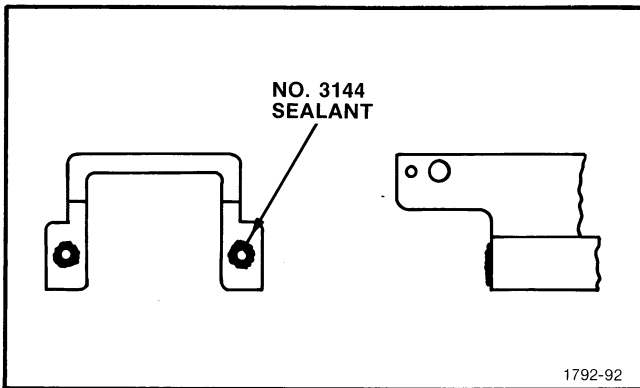

Fig. 5-39. Sealing of latch-assembly screwholes.

Distance Indicator Knob Replacement

If it is necessary to attach a knob shell/lens assembly to the DISTANCE indicator, form a bead of No. 3144

adhesive sealant (Tektronix Part No. 006-1171-00) at the interface of the DISTANCE indicator and the knob shell.

REPACKAGING FOR SHIPMENT

If the Tektronix instrument is to be shipped to a Tektronix Service Center for service or repair, attach a tag showing: owner (with address) and the name of an individual at your firm that can be contacted, complete instrument serial number and a description of the service required.

Save and re-use package in which your instrument was shipped. If the original packaging is unfit for use or not available, repackage the instrument as follows:

1. Obtain a carton of corrugated cardboard having inside dimensions of no less than six inches more than the instrument dimensions; this will allow for cushioning. Refer to the following table for carton test strength requirements.

2. Surround the instrument with polyethylene sheeting to protect the finish of the instrument.

3. Cushion the instrument on all sides by tightly packing dunnage or urethane foam between carton and instrument, allowing three inches on all sides.

4. Seal carton with shipping tape or industrial stapler.

SHIPPING CARTON TEST STRENGTH

Gross Weight (lb)	Carton Test Strength (lb)
0-10	200
10-30	275
30-120	375
120-140	500
140-160	600

OPTIONS

Option 1 provides discrete cable dielectric (relative propagation velocity) selections from 0.2 to 1.0 in .01 increments.

Option 4 provides a chart recorder for self-contained hard copy capability.

Option 5 provides metric calibration and metric front-panel notation.

Option 76 provides a crt with P7 phosphor, which is excellent for long-persistence display requirements.

POWER CORD OPTIONS

Option A1: 220 V/16 A, Universal Europe, 161-0132-00.

Option A2: 240 V/13 A, United Kingdom, 161-0133-00.

Option A3: 240 V/10 A, Australian, 161-0135-00.

Option A4: 240 V/15 A, North American, 161-0134-00.

Option A5: 250 V/6 A, Swiss, 161-0154-00.

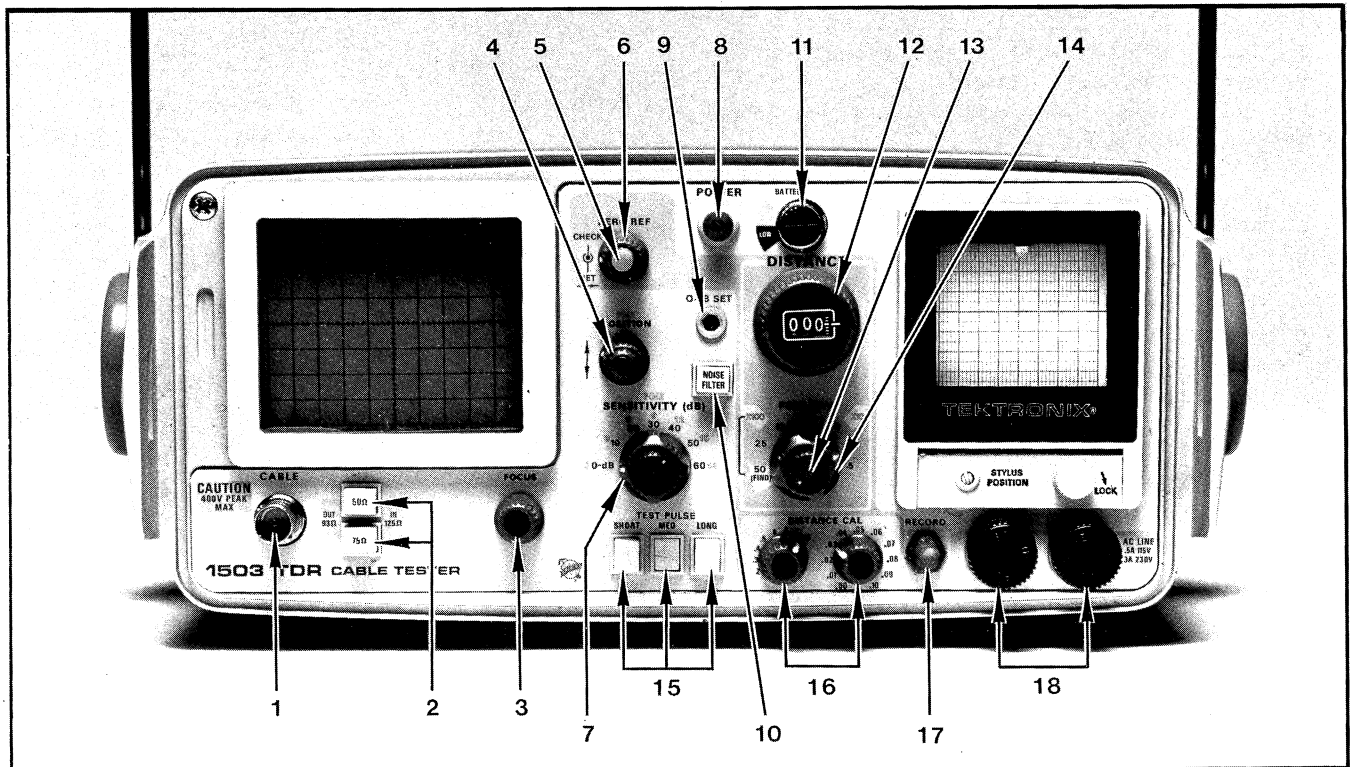

Fig. Option 1-1. Front-panel controls.

OPTION 1

1503 OPTION 1 differs from the 1503 standard model as follows:

1. The two front-panel CABLE DIELECTRIC pushbuttons have been replaced by two rotary DISTANCE CAL switches; the VAR adjustment has been deleted. To make these changes a PC Board (PC 9) has been added. See Fig. Option 1-2.

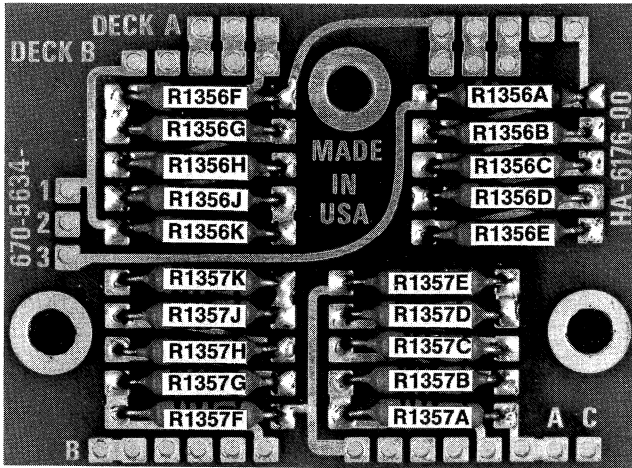

Fig. Option 1-2

2. The INTENSITY function has been removed and factory set; the FOCUS control has been relocated. A change in the High Voltage Board has been made accordingly. See Fig. Option 1-3.

3. RET LOSS (dB) has been renamed SENSITIVITY (dB).

4. IMPLS WIDTH has been redefined as TEST-PULSE, and the pushbuttons have been marked SHORT, MED, and LONG, instead of 10, 100, 1000.

Front-Panel Controls

1. CABLE Precision bnc connector used to transmit the impulse signal into the test cable and receive the reflected signal.
2. Impedance selectors Two push buttons used to select the 1503 output impedance. 50 Ω pushed in, selects 50 Ω impedance. 75 Ω pushed in, selects 75 Ω impedance. Both pushed in,

selects 125 Ω impedance. Both out, select 93 Ω impedance.

3. FOCUS Controls sharpness of crt display.
4. POSITION/FINE Vertical position controls for crt display.
5. ZERO REF CHECK Push button to check horizontal reference location of test impulse signal on crt.
6. ZERO REF SET Horizontal pulse position control for crt display. Sets test signal edge to a vertical reference line on the crt when the DISTANCE dial is at 000 or ZERO REF CHECK button is pushed.
7. SENSITIVITY (dB) Selects dB reference level of the reflected signal. 0—60 dB in seven calibrated steps. FINE adds 0—18 dB.
8. POWER Push-pull, off-on switch. Does not affect battery charging circuits.
9. 0 dB SET Screwdriver adjust for 0 dB reference level. Used to get amplitude of test pulse.
10. NOISE FILTER Reduces displayed noise. Display sweep rate is reduced by a factor of ten.
11. BATTERY Indicates relative charge of power pack.
12. DISTANCE Indicates the distance from 1503 to a point on the test cable; 0 to 25000 feet (0 to 500 metres) at X100 (X10). Disabled when the FEET/DIV (METRES/DIV) control is set to 50 (100) and the multiplier is set to X100 (X10).

PARTIAL TIME BASE GENERATOR

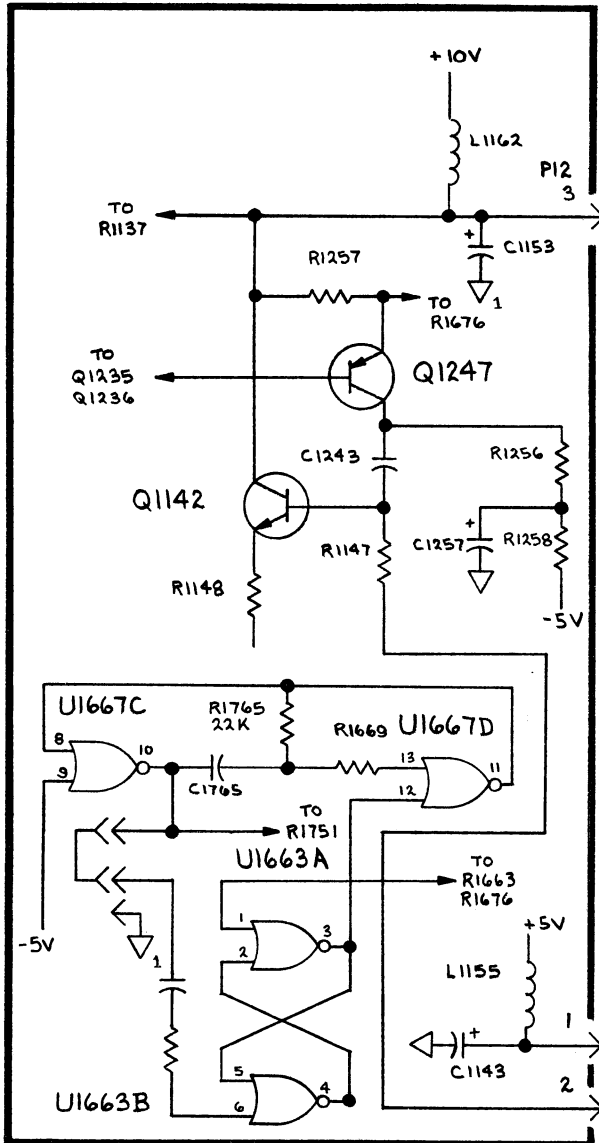

1503 OPTION 1

DISTANCE CAL. BOARD

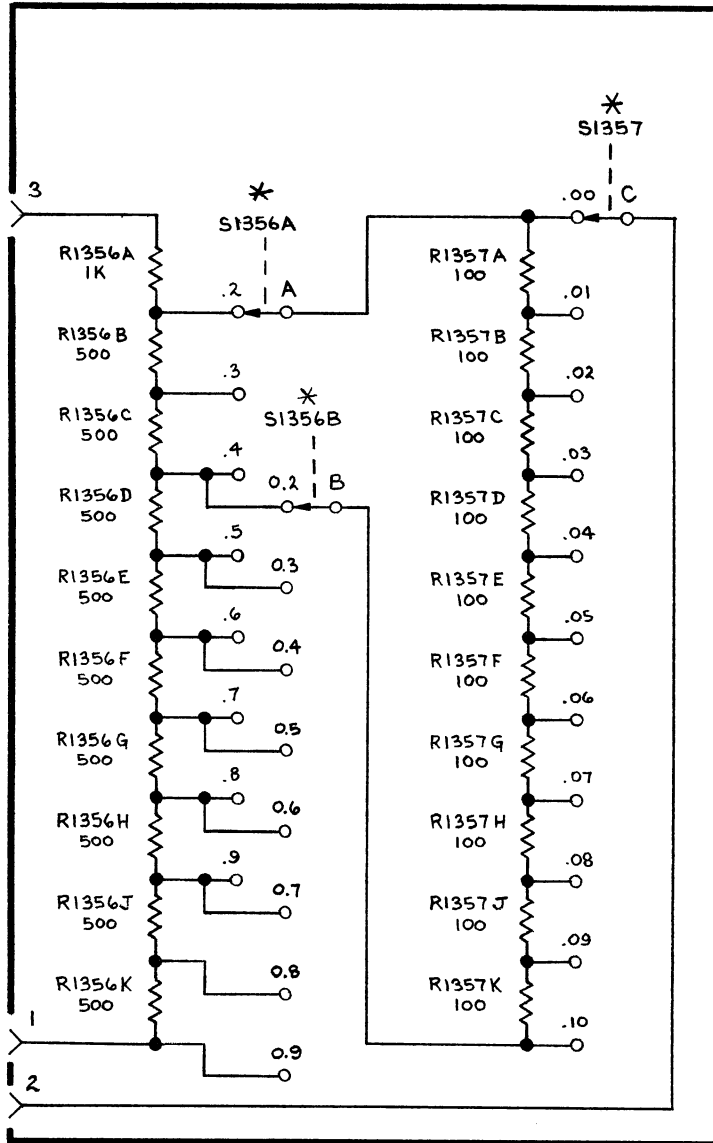

* SWITCHES
S1356A & B
AND S1357
LOCATED ON
FRONT PANEL

P/O HIGH VOLT. BOARD

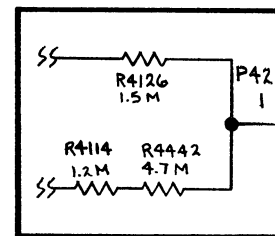

Fig. Option 1-3

Options—1503

- 13. X10 (X1)
X100 (X10) Two-position switch for X10 (X1) or X100 (X10) multiplier. Affects both DISTANCE dial and FEET/DIV (METRES/DIV) control.
- 14. FEET/DIV
(METRES/DIV) Selects horizontal deflection factor.
X10 (X1) = 5 to 500 feet/div (1 to 100 metres/div).
X100 (X10) = 50 to 5000 feet/div (10 to 1000 metres/div).
- 15. TEST PULSE Selects duration of test impulse; SHORT (10 ns), MED (100 ns), or LONG (1000 ns).
- 16. DISTANCE CAL Two rotary switches, providing direct calibration in terms of propagation velocity, expressed as a fraction of C (speed of light). The right switch provides settings from 00 to .01 in increments of .01 C. The left switch provides settings from .2 to .9 in increments of .1 C. The cable Vp factor is found by adding the two switch settings.
- 17. RECORD Two-position toggle switch. Used to start an X-Y Recorder or TEKTRONIX Y-T Chart recorder. Push up and hold momentarily to pre-heat stylus then release to start Chart recorder.
- 18. AC LINE
FUSES Protection fuses for the battery charger circuits.

CALIBRATION

Calibrate OPTION 1 according to the Calibration Procedure in the 1503 Instruction Manual, with the following exceptions:

Under control settings in all sections of the manual Calibration Procedure (Power Supply, Display, Vertical and Horizontal-Standard Version), change:

- (from)
- CABLE DIELECTRIC. Both Out
- VAR Clockwise
- (to)
- DISTANCE CAL Both Clockwise
(.9 and .1 = 1.0)

Replace parts q through y of the Power Supply portion of the manual Calibration Procedure with the following parts q through s.

q. Connect the voltmeter between TP4243 and TP4251 (see Output Amp-High Voltage Component pull-out page for test point locations).

r. CHECK—For a voltmeter reading of 60 mV ±5 mV.

s. ADJUST—R4222 (INTENSITY LIMIT) for a voltmeter reading that is inside the range of 55 mV to 65 mV. The adjustment is located on the HIGH VOLTAGE board and adjusted through the hole in the POWER SUPPLY board (see Fig. 4-1). Check for optimum trace brightness without blooming.

12. DISTANCE CAL

a. Set the FEET/DIV switch to five feet, multiplier to X10. Select 1 μs markers.

b. With the ZERO REF SET, position the display so that the leading edge of one time marker is on the first graticule line and the corresponding point of the next time marker is on the last graticule line (10 div).

c. Use the following table to check the DISTANCE CAL switches:

Switch Setting		Div Between
Left	Right	Markers, +0.4% to -3.6%
.9	.1	10
.9	.09	9.9
.9	.08	9.8
.9	.07	9.7
.9	.06	9.6
.9	.05	9.5
.9	.04	9.4
.9	.03	9.3
.9	.02	9.2
.9	.01	9.1
.9	.00	9.0
.8	.1	9.0
.7	.1	8.0
.6	.1	7.0
.5	.1	6.0
.4	.1	5.0
.3	.1	4.0
.2	.1	3.0

REPLACEABLE ELECTRICAL PARTS

PARTS ORDERING INFORMATION

Replacement parts are available from or through your local Tektronix, Inc. Field Office or representative.

Changes to Tektronix instruments are sometimes made to accommodate improved components as they become available, and to give you the benefit of the latest circuit improvements developed in our engineering department. It is therefore important, when ordering parts, to include the following information in your order: Part number, instrument type or number, serial number, and modification number if applicable.

If a part you have ordered has been replaced with a new or improved part, your local Tektronix, Inc. Field Office or representative will contact you concerning any change in part number.

Change information, if any, is located at the rear of this manual.

SPECIAL NOTES AND SYMBOLS

X000 Part first added at this serial number
00X Part removed after this serial number

ITEM NAME

In the Parts List, an Item Name is separated from the description by a colon (:). Because of space limitations, an Item Name may sometimes appear as incomplete. For further Item Name identification, the U.S. Federal Cataloging Handbook H6-1 can be utilized where possible.

ABBREVIATIONS

ACTR	ACTUATOR	PLSTC	PLASTIC
ASSY	ASSEMBLY	QTZ	QUARTZ
CAP	CAPACITOR	RECP	RECEPTACLE
CER	CERAMIC	RES	RESISTOR
CKT	CIRCUIT	RF	RADIO FREQUENCY
COMP	COMPOSITION	SEL	SELECTED
CONN	CONNECTOR	SEMICOND	SEMICONDUCTOR
ELCTLT	ELECTROLYTIC	SENS	SENSITIVE
ELEC	ELECTRICAL	VAR	VARIABLE
INCAND	INCANDESCENT	WW	WIREWOUND
LED	LIGHT EMITTING DIODE	XFMR	TRANSFORMER
NONWIR	NON WIREWOUND	XTAL	CRYSTAL

CROSS INDEX—MFR. CODE NUMBER TO MANUFACTURER

Mfr. Code	Manufacturer	Address	City, State, Zip
0000M	SONY/TEKTRONIX CORPORATION	P O BOX 14, HANEDA AIRPORT	TOKYO 149, JAPAN
00853	SANGAMO ELECTRIC CO., S. CAROLINA DIV.	P O BOX 128	PICKENS, SC 29671
01002	GENERAL ELECTRIC COMPANY, INDUSTRIAL AND POWER CAPACITOR PRODUCTS DEPARTMENT	JOHN STREET	HUDSON FALLS, NY 12839
01121	ALLEN-BRADLEY COMPANY	1201 2ND STREET SOUTH	MILWAUKEE, WI 53204
01295	TEXAS INSTRUMENTS, INC., SEMICONDUCTOR GROUP	P O BOX 5012, 13500 N CENTRAL EXPRESSWAY	DALLAS, TX 75222
02735	RCA CORPORATION, SOLID STATE DIVISION	ROUTE 202	SOMERVILLE, NY 08876
03508	GENERAL ELECTRIC COMPANY, SEMI-CONDUCTOR PRODUCTS DEPARTMENT	ELECTRONICS PARK	SYRACUSE, NY 13201
03888	KDI PYROFILM CORPORATION	60 S JEFFERSON ROAD	WHIPPANY, NJ 07981
04222	AVX CERAMICS, DIVISION OF AVX CORP.	P O BOX 867, 19TH AVE. SOUTH	MYRTLE BEACH, SC 29577
04713	MOTOROLA, INC., SEMICONDUCTOR PROD. DIV.	5005 E MCDOWELL RD, PO BOX 20923	PHOENIX, AZ 85036
07263	FAIRCHILD SEMICONDUCTOR, A DIV. OF FAIRCHILD CAMERA AND INSTRUMENT CORP.	464 ELLIS STREET	MOUNTAIN VIEW, CA 94042
09353	C AND K COMPONENTS, INC.	103 MORSE STREET	WATERTOWN, MA 02172
12697	CLAROSTAT MFG. CO., INC.	LOWER WASHINGTON STREET	DOVER, NH 03820
12969	UNITRODE CORPORATION	580 PLEASANT STREET	WATERTOWN, MA 02172
14099	SEMTECH CORP.	652 MITCHELL RD.	NEWBURY PARK, CA 91320
14552	MICRO SEMICONDUCTOR CORP.	2830 E FAIRVIEW ST.	SANTA ANA, CA 92704
14752	ELECTRO CUBE INC.	1710 S. DEL MAR AVE.	SAN GABRIEL, CA 91776
14936	GENERAL INSTRUMENT CORP., SEMICONDUCTOR PRODUCTS GROUP	P.O. BOX 600, 600 W. JOHN ST.	HICKSVILLE, NY 11802
15238	ITT SEMICONDUCTORS, A DIVISION OF INTER NATIONAL TELEPHONE AND TELEGRAPH CORP.	P.O. BOX 168, 500 BROADWAY	LAWRENCE, MA 01841
17856	SILICONIX, INC.	2201 LAURELWOOD DRIVE	SANTA CLARA, CA 95054
18324	SIGNETICS CORP.	811 E. ARQUES	SUNNYVALE, CA 94086
19396	ILLINOIS TOOL WORKS, INC. PAKTRON DIV.	900 FOLLIN LANE, SE	VIENNA, VA 22180
24138	INTERNATIONAL ELECTRONIC CORP.	316 S SERVICE RD, HUNTINGTON STA	MELVILLE, L.I., NY 11746
24546	CORNING GLASS WORKS, ELECTRONIC COMPONENTS DIVISION	550 HIGH STREET	BRADFORD, PA 16701
27014	NATIONAL SEMICONDUCTOR CORP.	2900 SEMICONDUCTOR DR.	SANTA CLARA, CA 95051
28480	HEWLETT-PACKARD CO., CORPORATE HQ.	1501 PAGE MILL RD.	PALO ALTO, CA 94304
32997	BOURNS, INC., TRIMPOT PRODUCTS DIV.	1200 COLUMBIA AVE.	RIVERSIDE, CA 92507
33096	COLORADO CRYSTAL CORPORATION	2303 W 8TH STREET	LOVELAND, CO 80537
34430	MONSANTO COMMERCIAL PRODUCT, CO. FABRICATOR PRODUCTS DIV.	BOX 3790, 611 EAST CERRITOS AVE.	ANAHEIM, CA 92803
50434	HEWLETT-PACKARD COMPANY	640 PAGE MILL ROAD	PALO ALTO, CA 94304
51642	CENTRE ENGINEERING INC.	2820 E COLLEGE AVENUE	STATE COLLEGE, PA 16801
56289	SPRAGUE ELECTRIC CO.	87 MARSHALL ST.	NORTH ADAMS, MA 01247
59660	TUSONIX INC.	2155 N FORBES BLVD	TUCSON, AZ 85705
71400	BUSSMAN MFG., DIVISION OF MCGRAW- EDISON CO.	2536 W. UNIVERSITY ST.	ST. LOUIS, MO 63107
71590	CENTRALAB ELECTRONICS, DIV. OF GLOBE-UNION, INC.	P O BOX 858	FORT DODGE, IA 50501
72982	ERIE TECHNOLOGICAL PRODUCTS, INC.	644 W. 12TH ST.	ERIE, PA 16512
73138	BECKMAN INSTRUMENTS, INC., HELIPOT DIV.	2500 HARBOR BLVD.	FULLERTON, CA 92634
75042	TRW ELECTRONIC COMPONENTS, IRC FIXED RESISTORS, PHILADELPHIA DIVISION	401 N. BROAD ST.	PHILADELPHIA, PA 19108
75915	LITTELFUSE, INC.	800 E. NORTHWEST HWY	DES PLAINES, IL 60016
78488	STACKPOLE CARBON CO.		ST. MARYS, PA 15857
80009	TEKTRONIX, INC.	P O BOX 500	BEAVERTON, OR 97077
81073	GRAYHILL, INC.	561 HILLGROVE AVE., PO BOX 373	LA GRANGE, IL 60525
83508	GRANT PULLEY AND HARDWARE CO.	HIGH ST.	WEST NYACK, NY 10994
84411	TRW ELECTRONIC COMPONENTS, TRW CAPACITORS	112 W. FIRST ST.	OGALLALA, NE 69153
90201	MALLORY CAPACITOR CO., DIV. OF P. R. MALLORY AND CO., INC.	3029 E. WASHINGTON STREET P. O. BOX 372	INDIANAPOLIS, IN 46206
91418	RADIO MATERIALS COMPANY, DIV. OF P.R. MALLORY AND COMPANY, INC.	4242 W BRYN MAWR	CHICAGO, IL 60646
91637	DALE ELECTRONICS, INC.	P. O. BOX 609	COLUMBUS, NE 68601

Ckt No.	Tektronix Part No.	Serial/Model No. Eff	Dscont	Name & Description	Mfr Code	Mfr Part Number
CIRCUIT BOARD ASSEMBLIES						
A1	670-3866-00	B010100	B082958	CKT BOARD ASSY:MAIN	80009	670-3866-00
A1	670-3866-01	B082959		CKT BOARD ASSY:MAIN	80009	670-3866-01
A1	670-4388-00	B010100	B082958	CKT BOARD ASSY:MAIN (OPTION 5 ONLY)	80009	670-4388-00
A1	670-4388-01	B082959		CKT BOARD ASSY:MAIN (OPTION 5 ONLY)	80009	670-4388-01
A2	670-3895-00	B010100	B029999	CKT BOARD ASSY:VERT AMPL/SLOW RAMP	80009	670-3895-00
A2	670-3895-01	B030000	B082958	CKT BOARD ASSY:VERT AMPL/SLOW RAMP	80009	670-3895-01
A2	670-3895-02	B082959		CKT BOARD ASSY:VERT AMPL/SLOW RAMP	80009	670-3895-02
A3	670-3130-00	B010100	B069999	CKT BOARD ASSY:OUTPUT AMPLIFIER	80009	670-3130-00
A3	670-3130-02	B070000	B082958	CKT BOARD ASSY:OUTPUT AMPLIFIER	80009	670-3130-02
A3	670-3130-03	B082959	B094379	CKT BOARD ASSY:OUTPUT AMPLIFIER	80009	670-3130-03
A3	670-3130-04	B094380		CKT BOARD ASSY:OUTPUT AMPLIFIER	80009	670-3130-04
A4	670-3010-00	B010100	B069999	CKT BOARD ASSY:SWEEP GEN	80009	670-3010-00
A4	670-3010-01	B070000	B082958	CKT BOARD ASSY:SWEEP GEN	80009	670-3010-01
A4	670-3010-02	B082959		CKT BOARD ASSY:SWEEP GEN	80009	670-3010-02
A5	670-3513-00	B010100	B019999	CKT BOARD ASSY:CHART RECORDER LOGIC	80009	670-3513-00
A5	670-3513-01	B020000	B082958	CKT BOARD ASSY:CHART RECORDER LOGIC	80009	670-3513-01
A5	670-3513-02	B082959		CKT BOARD ASSY:CHART RECORDER LOGIC	80009	670-3513-02
A6	670-3520-00	B010100	B020245	CKT BOARD ASSY:POWER	80009	670-3520-00
A6	670-3520-01	B020246	B082958	CKT BOARD ASSY:POWER	80009	670-3520-01
A6	670-3520-02	B082959		CKT BOARD ASSY:POWER	80009	670-3520-02
A7	670-3865-00	B010100	B082958	CKT BOARD ASSY:X-Y PLUG IN (016-0606-00 ONLY)	80009	670-3865-00
A7	670-3865-01	B082959		CKT BOARD ASSY:X-Y PLUG IN (016-0606-00 ONLY)	80009	670-3865-01
A8	670-5634-00			CKT BOARD ASSY:CABLE VP FACTOR (OPTION 1 ONLY)	80009	670-5634-00
A9	670-6592-00	XB090000		CKT BOARD ASSY:POWER FUSE JACK	80009	670-6592-00
A10	670-0364-00	XB093410		CKT BOARD ASSY:RESISTANCE SOCKET (NO ELECTRICAL PARTS)	80009	670-0364-00
A1	670-3866-00	B010100	B082958	CKT BOARD ASSY:MAIN	80009	670-3866-00
A1	670-3866-01	B082959		CKT BOARD ASSY:MAIN	80009	670-3866-01
A1	670-4388-00	B010100	B082958	CKT BOARD ASSY:MAIN (OPTION 5 ONLY)	80009	670-4388-00
A1	670-4388-01	B082959		CKT BOARD ASSY:MAIN (OPTION 5 ONLY)	80009	670-4388-01
C1143	290-0114-00			CAP., FXD, ELCTLT: 47UF, 20%, 6V	56289	150D476X0006B2
C1153	290-0134-00			CAP., FXD, ELCTLT: 22UF, 20%, 15V	56289	150D226X0015B2
C1227	285-0598-00			CAP., FXD, PLSTC: 0.01UF, 5%, 100V (OPTION 5 ONLY)	01002	61F10AC103
C1238	285-0650-00			CAP., FXD, PLSTC: 0.027UF, 5%, 100V	56289	192P27352
C1238	285-0719-00			CAP., FXD, PLSTC: 0.015UF, 5%, 100V (OPTION 5 ONLY)	84411	663UW-15351
C1243	283-0198-00			CAP., FXD, CER DI: 0.22UF, 20%, 50V	72982	8121N083Z5U0224M
C1249	281-0623-00	XB040710		CAP., FXD, CER DI: 650PF, 5%, 500V	04222	7001-1362
C1257	290-0530-00			CAP., FXD, ELCTLT: 68UF, 20%, 6V	90201	TDC686M006NLF
C1321	283-0203-00			CAP., FXD, CER DI: 0.47UF, 20%, 50V	72982	8131M058Z5U0474M
C1324	290-0530-00			CAP., FXD, ELCTLT: 68UF, 20%, 6V	90201	TDC686M006NLF
C1331	290-0530-00			CAP., FXD, ELCTLT: 68UF, 20%, 6V	90201	TDC686M006NLF
C1422	290-0530-00			CAP., FXD, ELCTLT: 68UF, 20%, 6V	90201	TDC686M006NLF
C1434	290-0530-00			CAP., FXD, ELCTLT: 68UF, 20%, 6V	90201	TDC686M006NLF
C1447	283-0203-00			CAP., FXD, CER DI: 0.47UF, 20%, 50V	72982	8131M058Z5U0474M
C1456	290-0517-00			CAP., FXD, ELCTLT: 6.8UF, 20%, 35V	56289	196D685X0035KA1
C1459	283-0104-00			CAP., FXD, CER DI: 2000PF, 5%, 500V	72982	811-565B202J
C1503	283-0103-00			CAP., FXD, CER DI: 180PF, 5%, 500V	59660	831-518-Z5D0181J
C1505	290-0530-00			CAP., FXD, ELCTLT: 68UF, 20%, 6V	90201	TDC686M006NLF

Replaceable Electrical Parts—1503

Ckt No.	Tektronix Part No.	Serial/Model No. Eff	Dscont	Name & Description	Mfr Code	Mfr Part Number
C1508	290-0530-00			CAP., FXD, ELCTLT: 68UF, 20%, 6V	90201	TDC686M006NLF
C1525	290-0114-00			CAP., FXD, ELCTLT: 47UF, 20%, 6V	56289	150D476X0006B2
C1531	283-0023-00			CAP., FXD, CER DI: 0.1UF, +80-20%, 12V	91418	MX0104Z1205R5
C1534	283-0625-00			CAP., FXD, MICA D: 220PF, 1%, 500V	00853	D105F221F0
C1536	290-0559-00			CAP., FXD, ELCTLT: 22UF, 20%, 35V	90201	TDC226M035WLG
C1538	283-0694-00			CAP., FXD, MICA D: 2240PF, 0.5%, 300V	00853	D193F2241E0
C1548	283-0193-00			CAP., FXD, CER DI: 510PF, 2%, 100V	72982	8121N130C0G0511G
C1554	290-0530-00			CAP., FXD, ELCTLT: 68UF, 20%, 6V	90201	TDC686M006NLF
C1556	283-0115-00			CAP., FXD, CER DI: 47PF, 5%, 200V	59660	805-519-COG0470J
C1558	283-0047-00			CAP., FXD, CER DI: 270PF, 5%, 500V	72982	0831522Z5D00271J
C1563	283-0060-00			CAP., FXD, CER DI: 100PF, 5%, 200V	72982	855-535U23101J
C1565	283-0154-00			CAP., FXD, CER DI: 22PF, 5%, 50V	72982	8111B061COG220J
C1574	283-0047-00			CAP., FXD, CER DI: 270PF, 5%, 500V	72982	0831522Z5D00271J
C1577	283-0047-00			CAP., FXD, CER DI: 270PF, 5%, 500V	72982	0831522Z5D00271J
C1578	290-0517-00			CAP., FXD, ELCTLT: 6.8UF, 20%, 35V	56289	196D685X0035KA1
C1585	290-0530-00			CAP., FXD, ELCTLT: 68UF, 20%, 6V	90201	TDC686M006NLF
C1586	290-0530-00			CAP., FXD, ELCTLT: 68UF, 20%, 6V	90201	TDC686M006NLF
C1593	285-0598-00			CAP., FXD, PLSTC: 0.01UF, 5%, 100V	01002	61F10AC103
C1595	283-0023-00			CAP., FXD, CER DI: 0.1UF, +80-20%, 12V	91418	MX0104Z1205R5
C1596	283-0115-00			CAP., FXD, CER DI: 47PF, 5%, 200V	59660	805-519-COG0470J
C1601	283-0000-00			CAP., FXD, CER DI: 0.001UF, +100-0%, 500V	59660	831-519-Z5U-102P
C1605	290-0530-00			CAP., FXD, ELCTLT: 68UF, 20%, 6V	90201	TDC686M006NLF
C1607	290-0530-00			CAP., FXD, ELCTLT: 68UF, 20%, 6V	90201	TDC686M006NLF
C1647	290-0517-00			CAP., FXD, ELCTLT: 6.8UF, 20%, 35V	56289	196D685X0035KA1
C1648	290-0559-00			CAP., FXD, ELCTLT: 22UF, 20%, 35V	90201	TDC226M035WLG
C1654	290-0530-00			CAP., FXD, ELCTLT: 68UF, 20%, 6V	90201	TDC686M006NLF
C1673	283-0115-00			CAP., FXD, CER DI: 47PF, 5%, 200V	59660	805-519-COG0470J
C1677	283-0115-00			CAP., FXD, CER DI: 47PF, 5%, 200V	59660	805-519-COG0470J
C1686	283-0032-00			CAP., FXD, CER DI: 470PF, 5%, 500V	72982	0831085Z5E00471J
C1687	283-0107-00			CAP., FXD, CER DI: 51PF, 5%, 200V	72982	8121B232COG0510J
C1697	283-0175-00			CAP., FXD, CER DI: 10PF, 5%, 200V	72982	8101B210COG0100J
C1698	283-0103-00			CAP., FXD, CER DI: 180PF, 5%, 500V	59660	831-518-Z5D0181J
C1701	290-0530-00			CAP., FXD, ELCTLT: 68UF, 20%, 6V	90201	TDC686M006NLF
C1706	290-0530-00			CAP., FXD, ELCTLT: 68UF, 20%, 6V	90201	TDC686M006NLF
C1715	285-0537-00			CAP., FXD, PPR DI: 0.5UF, 20%, 400V	14752	650B1B1E504
C1741	283-0203-00			CAP., FXD, CER DI: 0.47UF, 20%, 50V	72982	8131M058Z5U0474M
C1742	283-0209-00			CAP., FXD, CER DI: 1UF, 20%, 50V	51642	UC35050Z5U105MPS
C1743	290-0517-00			CAP., FXD, ELCTLT: 6.8UF, 20%, 35V	56289	196D685X0035KA1
C1762	283-0193-00			CAP., FXD, CER DI: 510PF, 2%, 100V	72982	8121N130C0G0511G
C1765	283-0114-00			CAP., FXD, CER DI: 0.0015UF, 5%, 200V	72982	805-509B152J
C1775	283-0159-00			CAP., FXD, CER DI: 18PF, 5%, 50V	72982	8111B065COG0180J
C1783	283-0107-00			CAP., FXD, CER DI: 51PF, 5%, 200V	72982	8121B232COG0510J
C1793	283-0076-00			CAP., FXD, CER DI: 27PF, 10%, 500V	56289	40C287A2
CR1358	152-0141-02			SEMICONV DEVICE: SILICON, 30V, 150MA	01295	1N4152R
CR1432	152-0141-02			SEMICONV DEVICE: SILICON, 30V, 150MA	01295	1N4152R
CR1433	150-1000-00			LT EMITTING DIO: RED, 650NM, 40MA MAX	34430	MV-50
CR1434	152-0333-00			SEMICONV DEVICE: SILICON, 55V, 200MA	07263	FDH-6012
CR1463	152-0141-02			SEMICONV DEVICE: SILICON, 30V, 150MA	01295	1N4152R
CR1556	152-0457-00			SEMICONV DEVICE: SILICON, 25V	28480	5082-2068
CR1557	152-0322-00	XB083169		SEMICONV DEVICE: SILICON, 15V, HOT CARRIER	50434	5082-2672
CR1558	152-0169-00			SEMICONV DEVICE: TUNNEL, 1MA, 10PF	03508	IN3712
CR1561	152-0141-02			SEMICONV DEVICE: SILICON, 30V, 150MA	01295	1N4152R
CR1563	152-0141-02			SEMICONV DEVICE: SILICON, 30V, 150MA	01295	1N4152R
CR1564	152-0141-02			SEMICONV DEVICE: SILICON, 30V, 150MA	01295	1N4152R
CR1572	152-0322-00	XB083169		SEMICONV DEVICE: SILICON, 15V, HOT CARRIER	50434	5082-2672
CR1574	152-0169-00			SEMICONV DEVICE: TUNNEL, 1MA, 10PF	03508	IN3712
CR1581	152-0141-02			SEMICONV DEVICE: SILICON, 30V, 150MA	01295	1N4152R
CR1582	152-0141-02			SEMICONV DEVICE: SILICON, 30V, 150MA	01295	1N4152R
CR1639	152-0107-00			SEMICONV DEVICE: SILICON, 400V, 400MA	01295	G727
CR1647	152-0141-02			SEMICONV DEVICE: SILICON, 30V, 150MA	01295	1N4152R

Ckt No.	Tektronix Part No.	Serial/Model No. Eff	Dscont	Name & Description	Mfr Code	Mfr Part Number
CR1648	152-0141-02			SEMICON D DEVICE:SILICON,30V,150MA	01295	1N4152R
CR1654	152-0141-02			SEMICON D DEVICE:SILICON,30V,150MA	01295	1N4152R
CR1659	152-0141-02			SEMICON D DEVICE:SILICON,30V,150MA	01295	1N4152R
CR1673	152-0141-02			SEMICON D DEVICE:SILICON,30V,150MA	01295	1N4152R
CR1688	152-0457-00			SEMICON D DEVICE:SILICON,25V	28480	5082-2068
CR1689	152-0457-00			SEMICON D DEVICE:SILICON,25V	28480	5082-2068
CR1696	152-0457-00			SEMICON D DEVICE:SILICON,25V	28480	5082-2068
CR1735	152-0107-00			SEMICON D DEVICE:SILICON,400V,400MA	01295	G727
CR1752	152-0141-02			SEMICON D DEVICE:SILICON,30V,150MA	01295	1N4152R
CR1755	152-0141-02			SEMICON D DEVICE:SILICON,30V,150MA	01295	1N4152R
CR1792	152-0457-00			SEMICON D DEVICE:SILICON,25V	28480	5082-2068
L1155	108-0598-00			COIL, RF:200UH	80009	108-0598-00
L1162	108-0598-00			COIL, RF:200UH	80009	108-0598-00
L1433	108-0598-00			COIL, RF:200UH	80009	108-0598-00
L1441	108-0215-00			COIL, RF:1.1UH	80009	108-0215-00
L1449	108-0598-00			COIL, RF:200UH	80009	108-0598-00
L1541	108-0833-00			COIL, RF:10.2UH	80009	108-0833-00
L1546	108-0832-00			COIL, RF:FIXED,88UH POT CORE	80009	108-0832-00
L1555	108-0598-00			COIL, RF:200UH	80009	108-0598-00
L1753	108-0598-00			COIL, RF:200UH	80009	108-0598-00
L1774	276-0647-00			CORE, EM: TOROID, FERRITE	78488	57-0126
Q1142	151-0302-00			TRANSISTOR:SILICON,NPN	07263	S038487
Q1235	151-0301-00			TRANSISTOR:SILICON,PNP	27014	2N2907A
Q1236	151-0302-00			TRANSISTOR:SILICON,NPN	07263	S038487
Q1246	151-1078-00			TRANSISTOR:SILICON,JFE,N-CHANNEL	17856	J2133
Q1247	151-0216-00			TRANSISTOR:SILICON,PNP	04713	SPS8803
Q1332	151-0221-00			TRANSISTOR:SILICON,PNP	04713	SPS246
Q1435	151-0188-00			TRANSISTOR:SILICON,PNP	04713	SPS6868K
Q1436	151-0301-00			TRANSISTOR:SILICON,PNP	27014	2N2907A
Q1551	151-0441-00			TRANSISTOR:SILICON,NPN	04713	SRF501
Q1556	151-0221-00			TRANSISTOR:SILICON,PNP	04713	SPS246
Q1558	151-0131-00	B010100	B083168	TRANSISTOR:GERMANIUM,PNP	04713	2N964
Q1558	151-0188-00	B083169		TRANSISTOR:SILICON,PNP	04713	SPS6868K
Q1559	151-0441-00			TRANSISTOR:SILICON,NPN	04713	SRF501
Q1565	151-0333-00			TRANSISTOR:SILICON,NPN,SEL FROM MPS918	04713	SPS1752
Q1571	151-0301-00			TRANSISTOR:SILICON,PNP	27014	2N2907A
Q1573	151-0441-00			TRANSISTOR:SILICON,NPN	04713	SRF501
Q1575	151-0441-00	B010100	B049999	TRANSISTOR:SILICON,NPN	04713	SRF501
Q1575	151-0302-00	B050000		TRANSISTOR:SILICON,NPN	07263	S038487
Q1578	151-0131-00	B010100	B083168	TRANSISTOR:GERMANIUM,PNP	04713	2N964
Q1578	151-0188-00	B083169		TRANSISTOR:SILICON,PNP	04713	SPS6868K
Q1588	151-0302-00			TRANSISTOR:SILICON,NPN	07263	S038487
Q1593	151-0302-00			TRANSISTOR:SILICON,NPN	07263	S038487
Q1594	151-1078-00			TRANSISTOR:SILICON,JFE,N-CHANNEL	17856	J2133
Q1637	151-0450-00			TRANSISTOR:SILICON,PNP,SEL FROM 2N5583	80009	151-0450-00
Q1657	151-1078-00			TRANSISTOR:SILICON,JFE,N-CHANNEL	17856	J2133
Q1658	151-0441-00	B010100	B049999	TRANSISTOR:SILICON,NPN	04713	SRF501
Q1658	151-0302-00	B050000		TRANSISTOR:SILICON,NPN	07263	S038487
Q1678	151-0221-00			TRANSISTOR:SILICON,PNP	04713	SPS246
Q1772	151-0302-00			TRANSISTOR:SILICON,NPN	07263	S038487
Q1775	151-0441-00			TRANSISTOR:SILICON,NPN	04713	SRF501
R1115	321-0976-04			RES.,FXD,FILM:602 OHM,0.1%,0.125W	91637	HFF188D60202B
R1117	321-0973-04			RES.,FXD,FILM:60.2K OHM,0.1%,0.125W	91637	MFF1816D60201B
R1118	321-0604-00			RES.,FXD,FILM:30K OHM,0.25%,0.125W	91637	MFF1816D30001C
R1127	321-0170-00			RES.,FXD,FILM:576 OHM,1%,0.125W	91637	MFF1816G576ROF
R1132	311-1337-00			RES.,VAR, NONWIR:25K OHM,10%,0.50W	73138	89-129-1
R1135	315-0473-00			RES.,FXD,CMPSN:47K OHM,5%,0.25W	01121	CB4735

Replaceable Electrical Parts—1503

Ckt No.	Tektronix Part No.	Serial/Model No. Eff	Dscont	Name & Description	Mfr Code	Mfr Part Number
R1137	321-0262-03			RES., FXD, FILM: 5.23K OHM, 0.25%, 0.125W	91637	MFF1816G52300F
R1147	315-0103-00			RES., FXD, CMPSN: 10K OHM, 5%, 0.25W	01121	CB1035
R1148	315-0223-00			RES., FXD, CMPSN: 22K OHM, 5%, 0.25W	01121	CB2235
R1158	321-0155-00			RES., FXD, FILM: 402 OHM, 1%, 0.125W	91637	MFF1816G402ROF
	-----			(NOT USED IN OPTION 1)		
R1216	311-1268-00			RES., VAR, NONWIR: 10K OHM, 10%, 0.50W	32997	3329P-L58-103
R1218	315-0223-00			RES., FXD, CMPSN: 22K OHM, 5%, 0.25W	01121	CB2235
R1227	321-0603-00			RES., FXD, FILM: 15K OHM, 0.25%, 0.125W	91637	MFF1816D15001C
R1228	321-0268-03			RES., FXD, FILM: 6.04K OHM, 0.25%, 0.125W	91637	MFF1816D60400C
R1228	321-0277-03			RES., FXD, FILM: 7.5K OHM, 0.25%, 0.125W	24546	NC55C7501C
	-----			(OPTION 5 ONLY)		
R1229	321-0239-03			RES., FXD, FILM: 3.01K OHM, 0.25%, 0.125W	91637	MFF1816D30100C
R1249	315-0273-00			RES., FXD, CMPSN: 27K OHM, 5%, 0.25W	01121	CB2735
R1256	315-0471-00			RES., FXD, CMPSN: 470 OHM, 5%, 0.25W	01121	CB4715
R1257	315-0103-00			RES., FXD, CMPSN: 10K OHM, 5%, 0.25W	01121	CB1035
R1258	315-0101-00			RES., FXD, CMPSN: 100 OHM, 5%, 0.25W	01121	CB1015
R1313	315-0333-00			RES., FXD, CMPSN: 33K OHM, 5%, 0.25W	01121	CB3335
R1314	315-0223-00			RES., FXD, CMPSN: 22K OHM, 5%, 0.25W	01121	CB2235
R1317	315-0243-00			RES., FXD, CMPSN: 24K OHM, 5%, 0.25W	01121	CB2435
	-----			(OPTION 5 ONLY)		
R1317	315-0563-00			RES., FXD, CMPSN: 56K OHM, 5%, 0.25W	01121	CB5635
R1319	315-0473-00			RES., FXD, CMPSN: 47K OHM, 5%, 0.25W	01121	CB4735
R1328	315-0101-00			RES., FXD, CMPSN: 100 OHM, 5%, 0.25W	01121	CB1015
R1336	315-0101-00			RES., FXD, CMPSN: 100 OHM, 5%, 0.25W	01121	CB1015
R1337	321-0227-00			RES., FXD, FILM: 2.26K OHM, 1%, 0.125W	91637	MFF1816G22600F
R1338	321-0235-00			RES., FXD, FILM: 2.74K OHM, 1%, 0.125W	91637	MFF1816G27400F
R1353	321-0243-00			RES., FXD, FILM: 3.32K OHM, 1%, 0.125W	91637	MFF1816G33200F
	-----			(NOT USED IN OPTION 1)		
R1354	315-0223-00			RES., FXD, CMPSN: 22K OHM, 5%, 0.25W	01121	CB2235
R1355	321-0221-00			RES., FXD, FILM: 1.96K OHM, 1%, 0.125W	91637	MFF1816G19600F
	-----			(NOT USED IN OPTION 1)		
R1356	321-0280-00			RES., FXD, FILM: 8.06K OHM, 1%, 0.125W	91637	MFF1816G80600F
	-----			(NOT USED IN OPTION 1)		
R1357	321-0272-00			RES., FXD, FILM: 6.65K OHM, 1%, 0.125W	91637	MFF1816G66500F
	-----			(NOT USED IN OPTION 1)		
R1406	311-1275-00			RES., VAR, NONWIR: 1M OHM, 10%, 0.50W	32997	3329P-L58-105
R1414	311-1270-00			RES., VAR, NONWIR: 12K OHM, 10%, 0.5W	32997	3329P-L58-253
R1421	315-0362-00			RES., FXD, CMPSN: 3.6K OHM, 5%, 0.25W	01121	CB3625
R1424	315-0821-00			RES., FXD, CMPSN: 820 OHM, 5%, 0.25W	01121	CB8215
R1431	315-0512-00			RES., FXD, CMPSN: 5.1K OHM, 5%, 0.25W	01121	CB5125
R1436	315-0200-00			RES., FXD, CMPSN: 20 OHM, 5%, 0.25W	01121	CB2005
R1457	315-0471-00			RES., FXD, CMPSN: 470 OHM, 5%, 0.25W	01121	CB4715
R1462	315-0222-00			RES., FXD, CMPSN: 2.2K OHM, 5%, 0.25W	01121	CB2225
R1477	315-0103-00			RES., FXD, CMPSN: 10K OHM, 5%, 0.25W	01121	CB1035
R1486	315-0103-00			RES., FXD, CMPSN: 10K OHM, 5%, 0.25W	01121	CB1035
R1496	315-0101-00			RES., FXD, CMPSN: 100 OHM, 5%, 0.25W	01121	CB1015
R1502	315-0105-00			RES., FXD, CMPSN: 1M OHM, 5%, 0.25W	01121	CB1055
R1506	315-0103-00			RES., FXD, CMPSN: 10K OHM, 5%, 0.25W	01121	CB1035
R1507	315-0101-00			RES., FXD, CMPSN: 100 OHM, 5%, 0.25W	01121	CB1015
R1508	315-0332-00			RES., FXD, CMPSN: 3.3K OHM, 5%, 0.25W	01121	CB3325
R1509	315-0101-00			RES., FXD, CMPSN: 100 OHM, 5%, 0.25W	01121	CB1015
R1532	315-0152-00			RES., FXD, CMPSN: 1.5K OHM, 5%, 0.25W	01121	CB1525
R1533	315-0102-00			RES., FXD, CMPSN: 1K OHM, 5%, 0.25W	01121	CB1025
R1544	315-0223-00			RES., FXD, CMPSN: 22K OHM, 5%, 0.25W	01121	CB2235
R1543	315-0102-00			RES., FXD, CMPSN: 1K OHM, 5%, 0.25W	01121	CB1025
R1545	315-0103-00			RES., FXD, CMPSN: 10K OHM, 5%, 0.25W	01121	CB1035
R1547	315-0470-00			RES., FXD, CMPSN: 47 OHM, 5%, 0.25W	01121	CB4705

Ckt No.	Tektronix Part No.	Serial/Model No. Eff	Dscont	Name & Description	Mfr Code	Mfr Part Number
R1552	315-0103-00			RES.,FXD,CMPSN:10K OHM,5%,0.25W	01121	CB1035
R1557	315-0223-00			RES.,FXD,CMPSN:22K OHM,5%,0.25W	01121	CB2235
R1562	315-0223-00			RES.,FXD,CMPSN:22K OHM,5%,0.25W	01121	CB2235
R1563	315-0304-00			RES.,FXD,CMPSN:300K OHM,5%,0.25W	01121	CB3045
R1576	315-0473-00			RES.,FXD,CMPSN:47K OHM,5%,0.25W	01121	CB4735
R1577	315-0102-00			RES.,FXD,CMPSN:1K OHM,5%,0.25W	01121	CB1025
R1582	315-0331-00	B010100	B010128	RES.,FXD,CMPSN:330 OHM,5%,0.25W	01121	CB3315
R1582	315-0221-00	B010129		RES.,FXD,CMPSN:220 OHM,5%,0.25W	01121	CB2215
R1584	315-0101-00			RES.,FXD,CMPSN:100 OHM,5%,0.25W	01121	CB1015
R1587	315-0101-00			RES.,FXD,CMPSN:100 OHM,5%,0.25W	01121	CB1015
R1588	315-0103-00			RES.,FXD,CMPSN:10K OHM,5%,0.25W	01121	CB1035
R1589	315-0223-00			RES.,FXD,CMPSN:22K OHM,5%,0.25W	01121	CB2235
R1592	315-0204-00			RES.,FXD,CMPSN:200K OHM,5%,0.25W	01121	CB2045
R1597	315-0473-00			RES.,FXD,CMPSN:47K OHM,5%,0.25W	01121	CB4735
R1599	315-0822-00			RES.,FXD,CMPSN:8.2K OHM,5%,0.25W	01121	CB8225
R1602	315-0101-00			RES.,FXD,CMPSN:100 OHM,5%,0.25W	01121	CB1015
R1603	315-0822-00			RES.,FXD,CMPSN:8.2K OHM,5%,0.25W	01121	CB8225
R1604	315-0101-00			RES.,FXD,CMPSN:100 OHM,5%,0.25W	01121	CB1015
R1606	315-0101-00			RES.,FXD,CMPSN:100 OHM,5%,0.25W	01121	CB1015
R1608	315-0103-00			RES.,FXD,CMPSN:10K OHM,5%,0.25W	01121	CB1035
R1633	321-0085-00			RES.,FXD,FILM:75 OHM,1%,0.125W	91637	MFF1816G75R00F
R1634	321-0094-00			RES.,FXD,FILM:93.1 OHM,1%,0.125W	91637	MFF1816G93R10F
R1635	321-0107-00			RES.,FXD,FILM:127 OHM,1%,0.125W	91637	MFF1816G127R0F
R1641	321-0068-00			RES.,FXD,FILM:49.9 OHM,1%,0.125W	91637	MFF1816G49R90F
R1643	315-0472-00			RES.,FXD,CMPSN:4.7K OHM,5%,0.25W	01121	CB4725
R1646	315-0472-00			RES.,FXD,CMPSN:4.7K OHM,5%,0.25W	01121	CB4725
R1651	315-0332-00			RES.,FXD,CMPSN:3.3K OHM,5%,0.25W	01121	CB3325
R1661	315-0102-00			RES.,FXD,CMPSN:1K OHM,5%,0.25W	01121	CB1025
R1663	315-0104-00			RES.,FXD,CMPSN:100K OHM,5%,0.25W	01121	CB1045
R1655	321-0169-00			RES.,FXD,FILM:562 OHM,1%,0.125W	91637	MFF1816G562R0F
R1664	315-0333-00			RES.,FXD,CMPSN:33K OHM,5%,0.25W	01121	CB3335
R1672	315-0392-00			RES.,FXD,CMPSN:3.9K OHM,5%,0.25W	01121	CB3925
R1673	315-0103-00			RES.,FXD,CMPSN:10K OHM,5%,0.25W	01121	CB1035
R1674	315-0103-00			RES.,FXD,CMPSN:10K OHM,5%,0.25W	01121	CB1035
R1669	315-0274-00			RES.,FXD,CMPSN:270K OHM,5%,0.25W	01121	CB2745
R1676	311-1273-00			RES.,VAR, NONWIR:200K OHM,10%,0.5W	32997	3329P-L58-204
R1677	315-0104-00			RES.,FXD,CMPSN:100K OHM,5%,0.25W	01121	CB1045
R1683	315-0103-00			RES.,FXD,CMPSN:10K OHM,5%,0.25W	01121	CB1035
R1687	317-0270-00			RES.,FXD,CMPSN:27 OHM,5%,0.125W	01121	BB2705
R1688	317-0270-00			RES.,FXD,CMPSN:27 OHM,5%,0.125W	01121	BB2705
R1692	315-0822-00			RES.,FXD,CMPSN:8.2K OHM,5%,0.25W	01121	CB8225
R1693	311-1267-00			RES.,VAR, NONWIR:5K OHM,10%,0.50W	32997	3329P-L58-502
R1694	315-0153-00			RES.,FXD,CMPSN:15K OHM,5%,0.25W	01121	CB1535
R1701	315-0101-00			RES.,FXD,CMPSN:100 OHM,5%,0.25W	01121	CB1015
R1724	321-0089-00			RES.,FXD,FILM:82.5 OHM,1%,0.125W	91637	MFF1816G82R50F
R1725	321-0149-00			RES.,FXD,FILM:348 OHM,1%,0.125W	91637	MFF1816G348R0F
R1731	321-0122-00			RES.,FXD,FILM:182 OHM,1%,0.125W	91637	MFF1816G182R0F
R1733	322-0097-00			RES.,FXD,FILM:100 OHM,1%,0.25W	75042	CEBT0-1000F
R1734	321-0076-00			RES.,FXD,FILM:60.4 OHM,1%,0.125W	91637	MFF1816G60R40F
R1743	315-0102-00			RES.,FXD,CMPSN:1K OHM,5%,0.25W	01121	CB1025
R1751	315-0103-00			RES.,FXD,CMPSN:10K OHM,5%,0.25W	01121	CB1035
R1752	315-0223-00			RES.,FXD,CMPSN:22K OHM,5%,0.25W	01121	CB2235
R1754	315-0472-00			RES.,FXD,CMPSN:4.7K OHM,5%,0.25W	01121	CB4725
R1755	315-0271-00			RES.,FXD,CMPSN:270 OHM,5%,0.25W	01121	CB2715
R1761	315-0102-00			RES.,FXD,CMPSN:1K OHM,5%,0.25W	01121	CB1025
R1762	315-0104-00			RES.,FXD,CMPSN:100K OHM,5%,0.25W	01121	CB1045
R1765	315-0513-00	B010100	B040709	RES.,FXD,CMPSN:51K OHM,5%,0.25W	01121	CB5135

Replaceable Electrical Parts—1503

Ckt No.	Tektronix Part No.	Serial/Model No. Eff	Dscont	Name & Description	Mfr Code	Mfr Part Number
R1765	315-0223-00	B040710		RES., FXD, CMPSN:22K OHM, 5%, 0.25W	01121	CB2235
R1773	315-0223-00			RES., FXD, CMPSN:22K OHM, 5%, 0.25W	01121	CB2235
R1774	315-0511-00			RES., FXD, CMPSN:510 OHM, 5%, 0.25W	01121	CB5115
R1781	315-0102-00			RES., FXD, CMPSN:1K OHM, 5%, 0.25W	01121	CB1025
R1782	315-0102-00			RES., FXD, CMPSN:1K OHM, 5%, 0.25W	01121	CB1025
R1783	315-0566-00			RES., FXD, CMPSN:56M OHM, 5%, 0.25W	01121	CB5665
R1784	317-0270-00			RES., FXD, CMPSN:27 OHM, 5%, 0.125W	01121	BB2705
R1785	317-0270-00			RES., FXD, CMPSN:27 OHM, 5%, 0.125W	01121	BB2705
R1791	321-0068-00			RES., FXD, FILM:49.9 OHM, 1%, 0.125W	91637	MFF1816G49R90F
R1793	315-0473-00			RES., FXD, CMPSN:47K OHM, 5%, 0.25W	01121	CB4735
R1796	311-1267-00			RES., VAR, NONWIR:5K OHM, 10%, 0.50W	32997	3329P-L58-502
S1156	263-0011-08			SWITCH, PB ASSY:1 PUSH, 10MM, 2CONTACTS (NOT USED IN OPTION 1)	80009	263-0011-08
S1252	263-0011-07			SWITCH, PB ASSY:1 PUSH, 10MM, 1CONTACT (NOT USED IN OPTION 1)	80009	263-0011-07
S1624	263-0010-00			SWITCH PB ASSY:1 PUSH, 7.5MM, W/2 CONTACTS	80009	263-0010-00
S1625	263-0011-00			SWITCH, PB ASSY:1 PUSH, 10 MM, W/4 CONTACTS	80009	263-0011-00
T1686	120-0544-00			XFMR, TOROID:	80009	120-0544-00
U1219	156-0158-00	B010100	B072079	MICROCIRCUIT, LI:DUAL OPERATIONAL AMPLIFIER	18324	MC1458N
U1219	156-0158-04	B072080		MICROCIRCUIT, LI:DUAL OPERATIONAL AMPLIFIER	01295	N99320JG
U1503	156-0686-00			MICROCIRCUIT, LI:OPNL AMPL, HIGH IMPEDANCE	02735	CA3130S
U1663	156-0349-00			MICROCIRCUIT, DI:QUAD 2-INPUT NOR GATE	27014	CD4001CJ
U1667	156-0349-00			MICROCIRCUIT, DI:QUAD 2-INPUT NOR GATE	27014	CD4001CJ
U1695	156-0158-00	B010100	B072079	MICROCIRCUIT, LI:DUAL OPERATIONAL AMPLIFIER	18324	MC1458N
U1695	156-0158-04	B072080		MICROCIRCUIT, LI:DUAL OPERATIONAL AMPLIFIER	01295	N99320JG
U1795	156-0335-00	B010100	B082958	MICROCIRCUIT, LI:OP AMPL, FET INPUT	27014	LH0042CH
U1795	156-1149-01	B082959		MICROCIRCUIT, LI:OPER AMPL, JFET, BURN-IN	27014	LF351N/A+
VR1649	152-0438-00			SEMICONV DEVICE:ZENER, 3W, 9.1V, 5%	12969	UZ1364

Ckt No.	Tektronix Part No.	Serial/Model No. Eff	Dscont	Name & Description	Mfr Code	Mfr Part Number
A2	670-3895-00	B010100	B029999	CKT BOARD ASSY:VERT AMPL/SLOW RAMP	80009	670-3895-00
A2	670-3895-01	B030000	B082958	CKT BOARD ASSY:VERT AMPL/SLOW RAMP	80009	670-3895-01
A2	670-3895-02	B082959		CKT BOARD ASSY:VERT AMPL/SLOW RAMP	80009	670-3895-02
C2137	283-0000-00			CAP., FXD, CER DI:0.001UF,+100-0%,500V	59660	831-519-Z5U-102P
C2138	290-0530-00			CAP., FXD, ELCTLT:68UF,20%,6V	90201	TDC686M006NLF
C2146	283-0111-00			CAP., FXD, CER DI:0.1UF,20%,50V	72982	8121-N088Z5U104M
C2147	290-0530-00			CAP., FXD, ELCTLT:68UF,20%,6V	90201	TDC686M006NLF
C2158	283-0340-00			CAP., FXD, CER DI:45PF,5%,1000V	72982	898-000 A 450J
C2229	290-0530-00			CAP., FXD, ELCTLT:68UF,20%,6V	90201	TDC686M006NLF
C2232	290-0530-00			CAP., FXD, ELCTLT:68UF,20%,6V	90201	TDC686M006NLF
C2241	283-0111-00			CAP., FXD, CER DI:0.1UF,20%,50V	72982	8121-N088Z5U104M
C2325	290-0534-00			CAP., FXD, ELCTLT:1UF,20%,35V	56289	196D105X0035HA1
C2345	290-0512-00	XB030000		CAP., FXD, ELCTLT:22UF,20%,15V	56289	196D226X0015KA1
C2349	283-0115-00			CAP., FXD, CER DI:47PF,5%,200V	59660	805-519-C0G0470J
C2351	283-0204-00			CAP., FXD, CER DI:0.01UF,20%,50V	72982	8121N061Z5U0103M
C2352	285-1056-00			CAP., FXD, PLSTC:1UF,2%,50V	14752	650B1A105G
C2356	283-0624-00			CAP., FXD, MICA D:1300PF,2%,500V	00853	D195F132G0
CR2159	152-0141-02			SEMICONV DEVICE:SILICON,30V,150MA	01295	1N4152R
CR2216	152-0141-02			SEMICONV DEVICE:SILICON,30V,150MA	01295	1N4152R
CR2217	152-0141-02			SEMICONV DEVICE:SILICON,30V,150MA	01295	1N4152R
CR2262	152-0141-02			SEMICONV DEVICE:SILICON,30V,150MA	01295	1N4152R
CR2324	152-0141-02			SEMICONV DEVICE:SILICON,30V,150MA	01295	1N4152R
CR2341	152-0141-02			SEMICONV DEVICE:SILICON,30V,150MA	01295	1N4152R
CR2344	152-0141-02	XB030000		SEMICONV DEVICE:SILICON,30V,150MA	01295	1N4152R
CR2358	152-0141-02			SEMICONV DEVICE:SILICON,30V,150MA	01295	1N4152R
Q2161	151-0410-00			TRANSISTOR:SILICON,PNP	80009	151-0410-00
Q2162	151-0410-00			TRANSISTOR:SILICON,PNP	80009	151-0410-00
Q2246	151-1054-00			TRANSISTOR:SILICON,JFE,N-CHANNEL,DUAL	80009	151-1054-00
Q2248	151-1022-00			TRANSISTOR:FET,N-CHAN,SI,F1782,TO-18	80009	151-1022-00
Q2249	151-1022-00			TRANSISTOR:FET,N-CHAN,SI,F1782,TO-18	80009	151-1022-00
Q2257	151-1022-00			TRANSISTOR:FET,N-CHAN,SI,F1782,TO-18	80009	151-1022-00
Q2258	151-1022-00			TRANSISTOR:FET,N-CHAN,SI,F1782,TO-18	80009	151-1022-00
Q2259	151-0410-00			TRANSISTOR:SILICON,PNP	80009	151-0410-00
Q2341	151-0410-00			TRANSISTOR:SILICON,PNP	80009	151-0410-00
Q2342	151-0410-00			TRANSISTOR:SILICON,PNP	80009	151-0410-00
Q2345	151-0410-00			TRANSISTOR:SILICON,PNP	80009	151-0410-00
R2137	315-0623-00			RES.,FXD,CMPSN:62K OHM,5%,0.25W	01121	CB6235
R2138	315-0203-00			RES.,FXD,CMPSN:20K OHM,5%,0.25W	01121	CB2035
R2139	315-0153-00			RES.,FXD,CMPSN:15K OHM,5%,0.25W	01121	CB1535
R2142	315-0123-00			RES.,FXD,CMPSN:12K OHM,5%,0.25W	01121	CB1235
R2144	315-0393-00			RES.,FXD,CMPSN:39K OHM,5%,0.25W	01121	CB3935
R2146	315-0103-00			RES.,FXD,CMPSN:10K OHM,5%,0.25W	01121	CB1035
R2149	316-0186-00			RES.,FXD,CMPSN:18M OHM,10%,0.25W	01121	CB1861
R2157	315-0473-00	B010100	B010128	RES.,FXD,CMPSN:47K OHM,5%,0.25W	01121	CB4735
R2157	315-0333-00	B010129		RES.,FXD,CMPSN:33K OHM,5%,0.25W	01121	CB3335
R2158	321-0422-00			RES.,FXD,FILM:243K OHM,1%,0.125W	91637	MFF1816G24302F
R2166	315-0185-00			RES.,FXD,CMPSN:1.8M OHM,5%,0.25W	01121	CB1855
R2220	315-0105-00			RES.,FXD,CMPSN:1M OHM,5%,0.25W	01121	CB1055
R2221	321-0766-06			RES.,FXD,FILM:4.053K OHM,0.25%,0.125W	91637	MFF1816C40530C
R2222	321-0770-03			RES.,FXD,FILM:4.204K OHM,0.25%,0.125W	91637	MFF1816D42040C
R2223	321-0931-03			RES.,FXD,FILM:1.11K OHM,0.25%,0.125W	91637	MFF1816D11100C
R2224	321-0193-03			RES.,FXD,FILM:1K OHM,0.25%,0.125W	91637	MFF1816D10000C
R2225	315-0330-00			RES.,FXD,CMPSN:33 OHM,5%,0.25W	01121	CB3305
R2226	321-0749-06			RES.,FXD,FILM:450 OHM,0.25%,0.125W	91637	MFF1816C450R0C
R2227	321-0912-03			RES.,FXD,FILM:408 OHM,0.25%,0.125W	24546	NC55C4080C
R2228	321-0781-06			RES.,FXD,FILM:400K OHM,0.25%,0.125W	91637	MFF1816C40002C
R2229	321-0289-00			RES.,FXD,FILM:10K OHM,1%,0.125W	91637	MFF1816G10001F

Replaceable Electrical Parts—1503

Ckt No.	Tektronix Part No.	Serial/Model No. Eff	Dscont	Name & Description	Mfr Code	Mfr Part Number
R2233	315-0393-00			RES., FXD, CMPSN: 39K OHM, 5%, 0.25W	01121	CB3935
R2235	315-0330-00			RES., FXD, CMPSN: 33 OHM, 5%, 0.25W	01121	CB3305
R2236	315-0104-00			RES., FXD, CMPSN: 100K OHM, 5%, 0.25W	01121	CB1045
R2237	315-0104-00			RES., FXD, CMPSN: 100K OHM, 5%, 0.25W	01121	CB1045
R2242	315-0333-00			RES., FXD, CMPSN: 33K OHM, 5%, 0.25W	01121	CB3335
R2247	315-0105-00			RES., FXD, CMPSN: 1M OHM, 5%, 0.25W	01121	CB1055
R2251	315-0155-00			RES., FXD, CMPSN: 1.5M OHM, 5%, 0.25W	01121	CB1555
R2258	315-0223-00			RES., FXD, CMPSN: 22K OHM, 5%, 0.25W	01121	CB2235
R2266	315-0105-00			RES., FXD, CMPSN: 1M OHM, 5%, 0.25W	01121	CB1055
R2267	321-0318-00			RES., FXD, FILM: 20K OHM, 1%, 0.125W	91637	MFF1816G20001F
R2311	315-0682-00	B010100	B029999	RES., FXD, CMPSN: 6.8K OHM, 5%, 0.25W	01121	CB6825
R2311	315-0682-00	B030000		RES., FXD, CMPSN: 6.8K OHM, 5%, 0.25W	01121	CB6825
R2321	321-1399-06			RES., FXD, FILM: 142K OHM, 0.25%, 0.125W	91637	MFF1816C14202C
R2322	321-0996-03			RES., FXD, FILM: 99K OHM, 0.25%, 0.125W	24546	NC55C9902C
R2323	321-0679-00			RES., FXD, FILM: 34K OHM, 0.5%, 0.125W	91637	MFF1816D34001D
R2324	315-0224-00			RES., FXD, CMPSN: 220K OHM, 5%, 0.25W	01121	CB2245
R2325	321-0622-00			RES., FXD, FILM: 37.96K OHM, 0.25%, 0.125W	91637	MFF1816D37961C
R2326	321-1283-03			RES., FXD, FILM: 8.76K OHM, 0.25%, 0.125W	91637	MFF1816D87600C
R2337	315-0104-00			RES., FXD, CMPSN: 100K OHM, 5%, 0.25W	01121	CB1045
R2345	315-0103-00	XB030000		RES., FXD, CMPSN: 10K OHM, 5%, 0.25W	01121	CB1035
R2346	315-0105-00			RES., FXD, CMPSN: 1M OHM, 5%, 0.25W	01121	CB1055
R2347	315-0105-00			RES., FXD, CMPSN: 1M OHM, 5%, 0.25W	01121	CB1055
R2348	315-0105-00			RES., FXD, CMPSN: 1M OHM, 5%, 0.25W	01121	CB1055
R2353	325-0199-00			RES., FXD, FILM: 24M OHM, 2%, 0.25W	03888	PVC60-G24004G
R2354	315-0272-00			RES., FXD, CMPSN: 2.7K OHM, 5%, 0.25W	01121	CB2725
R2355	315-0223-00			RES., FXD, CMPSN: 22K OHM, 5%, 0.25W	01121	CB2235
R2361	321-0321-00			RES., FXD, FILM: 21.5K OHM, 1%, 0.125W	91637	MFF1816G21501F
R2363	321-0321-00			RES., FXD, FILM: 21.5K OHM, 1%, 0.125W	91637	MFF1816G21501F
S2254	260-1445-02			SWITCH, PUSH: DPDT, W/8 POLES/SPRING	80009	260-1445-02
U2131	156-0067-00	B010100	B072079	MICROCIRCUIT, LI: OPERATIONAL AMPLIFIER	02735	85145
U2131	156-0067-12	B072080		MICROCIRCUIT, LI: OPERATIONAL AMPLIFIER	01295	UA741CJG
U2136	156-0067-00	B010100	B072079	MICROCIRCUIT, LI: OPERATIONAL AMPLIFIER	02735	85145
U2136	156-0067-12	B072080		MICROCIRCUIT, LI: OPERATIONAL AMPLIFIER	01295	UA741CJG
U2143	156-0067-00			MICROCIRCUIT, LI: OPERATIONAL AMPLIFIER	02735	85145
U2332	156-0350-00	B010100	B082958	MICROCIRCUIT, DI: QUAD 2-INPUT NAND GATE	80009	156-0350-00
U2332	156-0350-02	B082959		MICROCIRCUIT, DI: QUAD 2 INPUT NAND GATE, SEL	80009	156-0350-02
VR2212	152-0149-00	B010100	B029999	SEMICONV DEVICE: ZENER, 0.4W, 10V, 5%	04713	SZG35009K3
VR2212	152-0149-00	B030000		SEMICONV DEVICE: ZENER, 0.4W, 10V, 5% (SELECTED)	04713	SZG35009K3

Ckt No.	Tektronix Part No.	Serial/Model No. Eff	Dscont	Name & Description	Mfr Code	Mfr Part Number
A3	670-3130-00	B010100	B069999	CKT BOARD ASSY:OUTPUT AMPLIFIER	80009	670-3130-00
A3	670-3130-02	B070000	B082958	CKT BOARD ASSY:OUTPUT AMPLIFIER	80009	670-3130-02
A3	670-3130-03	B082959	B094379	CKT BOARD ASSY:OUTPUT AMPLIFIER	80009	670-3130-03
A3	670-3130-04	B094380		CKT BOARD ASSY:OUTPUT AMPLIFIER	80009	670-3130-04
C3132	283-0067-00			CAP., FXD, CER DI:0.001UF, 10%, 200V	59660	835-515-Z5D0102K
C3219	283-0116-00			CAP., FXD, CER DI:820PF, 5%, 500V	72982	801-547B821J
C3226	283-0116-00			CAP., FXD, CER DI:820PF, 5%, 500V	72982	801-547B821J
C3233	283-0114-00			CAP., FXD, CER DI:0.0015UF, 5%, 200V	72982	805-509B152J
C3241	290-0534-00			CAP., FXD, ELCTLT:1UF, 20%, 35V	56289	196D105X0035HA1
C3246	290-0534-00			CAP., FXD, ELCTLT:1UF, 20%, 35V	56289	196D105X0035HA1
Q3113	151-0341-00			TRANSISTOR: SILICON, NPN	07263	S040065
Q3114	151-0341-00			TRANSISTOR: SILICON, NPN	07263	S040065
Q3118	151-0279-00			TRANSISTOR: SILICON, NPN	01295	SGC2622
Q3137	151-0341-00			TRANSISTOR: SILICON, NPN	07263	S040065
Q3139	151-0341-00			TRANSISTOR: SILICON, NPN	07263	S040065
Q3221	151-0279-00			TRANSISTOR: SILICON, NPN	01295	SGC2622
Q3232	151-0279-00			TRANSISTOR: SILICON, NPN	01295	SGC2622
Q3235	151-0341-00			TRANSISTOR: SILICON, NPN	07263	S040065
Q3236	151-0279-00			TRANSISTOR: SILICON, NPN	01295	SGC2622
R3112	321-0280-00	B010100	B069999	RES., FXD, FILM:8.06K OHM, 1%, 0.125W	91637	MFF1816G80600F
R3112	321-0251-00	B070000	B094379	RES., FXD, FILM:4.02K OHM, 1%, 0.125W	91637	MFF1816G40200F
R3112	321-0263-00	B094380		RES., FXD, FILM:5.36K OHM, 1%, 0.125W	91637	MFF1816G53600F
R3114	321-0251-00	B010100	B069999	RES., FXD, FILM:4.02K OHM, 1%, 0.125W	91637	MFF1816G40200F
R3114	321-0222-00	B070000	B094379	RES., FXD, FILM:2K OHM, 1%, 0.125W	91637	MFF1816G20000F
R3114	321-0178-00	B094380		RES., FXD, FILM:698 OHM, 1%, 0.125W	91637	MFF1816G698R0F
R3115	321-0251-00	B010100	B069999	RES., FXD, FILM:4.02K OHM, 1%, 0.125W	91637	MFF1816G40200F
R3115	321-0222-00	B070000	B094379	RES., FXD, FILM:2K OHM, 1%, 0.125W	91637	MFF1816G20000F
R3115	321-0178-00	B094380		RES., FXD, FILM:698 OHM, 1%, 0.125W	91637	MFF1816G698R0F
R3116	321-0306-00	B010100	B069999	RES., FXD, FILM:15K OHM, 1%, 0.125W	91637	MFF1816G15001F
R3116	321-0277-00	B070000		RES., FXD, FILM:7.5K OHM, 1%, 0.125W	91637	MFF1816G75000F
R3121	315-0474-00	B010100	B069999	RES., FXD, CMPSN:470K OHM, 5%, 0.25W	01121	CB4745
R3121	321-0420-00	B070000		RES., FXD, FILM:232K OHM, 1%, 0.125W	91637	MFF1816G23202F
R3122	315-0474-00	B010100	B069999	RES., FXD, CMPSN:470K OHM, 5%, 0.25W	01121	CB4745
R3122	321-0420-00	B070000		RES., FXD, FILM:232K OHM, 1%, 0.125W	91637	MFF1816G23202F
R3124	315-0203-00			RES., FXD, CMPSN:20K OHM, 5%, 0.25W	01121	CB2035
R3126	315-0123-00	B010100	B069999	RES., FXD, CMPSN:12K OHM, 5%, 0.25W	01121	CB1235
R3126	321-0267-00	B070000		RES., FXD, FILM:5.9K OHM, 1%, 0.125W	91637	MFF1816G59000F
R3131	315-0103-00			RES., FXD, CMPSN:10K OHM, 5%, 0.25W	01121	CB1035
R3133	315-0754-00	B010100	B069999	RES., FXD, CMPSN:750K OHM, 5%, 0.25W	01121	CB7545
R3133	321-0440-00	B070000		RES., FXD, FILM:374K OHM, 1%, 0.125W	91637	MFF1816G37402F
R3134	315-0754-00	B010100	B069999	RES., FXD, CMPSN:750K OHM, 5%, 0.25W	01121	CB7545
R3134	321-0440-00	B070000		RES., FXD, FILM:374K OHM, 1%, 0.125W	91637	MFF1816G37402F
R3135	321-0308-00	B010100	B069999	RES., FXD, FILM:15.8K OHM, 1%, 0.125W	91637	MFF1816G15801F
R3135	321-0279-00	B070000		RES., FXD, FILM:7.87K OHM, 1%, 0.125W	91637	MFF1816G78700F
R3136	315-0104-00			RES., FXD, CMPSN:100K OHM, 5%, 0.25W	01121	CB1045
R3138	315-0104-00			RES., FXD, CMPSN:100K OHM, 5%, 0.25W	01121	CB1045
R3139	321-0251-00	B010100	B069999	RES., FXD, FILM:4.02K OHM, 1%, 0.125W	91637	MFF1816G40200F
R3139	321-0222-00	B070000		RES., FXD, FILM:2K OHM, 1%, 0.125W	91637	MFF1816G20000F
R3142	315-0102-00			RES., FXD, CMPSN:1K OHM, 5%, 0.25W	01121	CB1025
R3143	311-1556-00			RES., VAR, NONWIR:50K OHM, 20%, 0.50W	73138	91-78-0
R3146	321-0251-00	B010100	B069999	RES., FXD, FILM:4.02K OHM, 1%, 0.125W	91637	MFF1816G40200F
R3146	321-0222-00	B070000		RES., FXD, FILM:2K OHM, 1%, 0.125W	91637	MFF1816G20000F
R3148	315-0204-00			RES., FXD, CMPSN:200K OHM, 5%, 0.25W	01121	CB2045
R3149	315-0224-00			RES., FXD, CMPSN:220K OHM, 5%, 0.25W	01121	CB2245
R3212	321-0325-00	B010100	B069999	RES., FXD, FILM:23.7K OHM, 1%, 0.125W	91637	MFF1816G23701F
R3212	321-0297-00	B070000		RES., FXD, FILM:12.1K OHM, 1%, 0.125W	91637	MFF1816G12101F

Replaceable Electrical Parts—1503

Ckt No.	Tektronix Part No.	Serial/Model No. Eff	Dscont	Name & Description	Mfr Code	Mfr Part Number
R3213	311-1556-00	B010100	B069999	RES.,VAR, NONWIR:50K OHM,20%,0.50W	73138	91-78-0
R3213	311-1557-00	B070000		RES.,VAR, NONWIR:25K OHM,20%,0.50W	73138	91-79-0
R3216	321-0325-00	B010100	B069999	RES.,FXD,FILM:23.7K OHM,1%,0.125W	91637	MFF1816G23701F
R3216	321-0297-00	B070000		RES.,FXD,FILM:12.1K OHM,1%,0.125W	91637	MFF1816G12101F
R3217	311-1557-00	B010100	B069999	RES.,VAR, NONWIR:25K OHM,20%,0.50W	73138	91-79-0
R3217	311-1559-00	B070000		RES.,VAR, NONWIR:10K OHM,20%,0.50W	73138	91-81-0
R3219	315-0102-00			RES.,FXD,CMPNS:1K OHM,5%,0.25W	01121	CB1025
R3225	315-0104-00			RES.,FXD,CMPNS:100K OHM,5%,0.25W	01121	CB1045
R3226	315-0102-00			RES.,FXD,CMPNS:1K OHM,5%,0.25W	01121	CB1025
R3229	315-0105-00			RES.,FXD,CMPNS:1M OHM,5%,0.25W	01121	CB1055
R3233	315-0363-00	B010100	B069999	RES.,FXD,CMPNS:36K OHM,5%,0.25W	01121	CB3635
R3233	321-0313-00	B070000		RES.,FXD,FILM:17.8K OHM,1%,0.125W	91637	MFF1816G17801F
R3234	315-0183-00	B010100	B069999	RES.,FXD,CMPNS:18K OHM,5%,0.25W	01121	CB1835
R3234	321-0284-00	B070000		RES.,FXD,FILM:8.87K OHM,1%,0.125W	91637	MFF1816G88700F
R3237	311-1554-00			RES.,VAR, NONWIR:200K OHM,20%,0.50W	73138	91-76-0
R3238	315-0183-00	B010100	B069999	RES.,FXD,CMPNS:18K OHM,5%,0.25W	01121	CB1835
R3238	321-0284-00	B070000		RES.,FXD,FILM:8.87K OHM,1%,0.125W	91637	MFF1816G88700F
R3242	311-1554-00			RES.,VAR, NONWIR:200K OHM,20%,0.50W	73138	91-76-0
R3248	311-1554-00			RES.,VAR, NONWIR:200K OHM,20%,0.50W	73138	91-76-0
R3249	315-0204-00			RES.,FXD,CMPNS:200K OHM,5%,0.25W	01121	CB2045
U3123	156-0350-00	B010100	B082958	MICROCIRCUIT,DI:QUAD 2-INPUT NAND GATE	80009	156-0350-00
U3123	156-0350-02	B082959		MICROCIRCUIT,DI:QUAD 2 INPUT NAND GATE,SEL	80009	156-0350-02
U3223	156-0289-00			MICROCIRCUIT,DI:QUAD BILATERAL SWITCH	07263	74LS95(PC OR DC)

Ckt No.	Tektronix Part No.	Serial/Model No. Eff	Dscont	Name & Description	Mfr Code	Mfr Part Number
A4	670-3010-00	B010100	B069999	CKT BOARD ASSY:SWEEP GEN	80009	670-3010-00
A4	670-3010-01	B070000	B082958	CKT BOARD ASSY:SWEEP GEN	80009	670-3010-01
A4	670-3010-02	B082959		CKT BOARD ASSY:SWEEP GEN	80009	670-3010-02
C4118	283-0068-00			CAP., FXD, CER DI:0.01UF,+100-0%,500V	56289	19C241
C4119	285-1093-00			CAP., FXD, PLSTC:0.027UF,0.1%,200V	19396	51-17243
C4128	283-0068-00			CAP., FXD, CER DI:0.01UF,+100-0%,500V	56289	19C241
C4134	283-0000-00			CAP., FXD, CER DI:0.001UF,+100-0%,500V	59660	831-519-Z5U-102P
C4135	283-0000-00			CAP., FXD, CER DI:0.001UF,+100-0%,500V	59660	831-519-Z5U-102P
C4312	285-1093-00			CAP., FXD, PLSTC:0.027UF,0.1%,200V	19396	51-17243
C4321	285-1093-00			CAP., FXD, PLSTC:0.027UF,0.1%,200V	19396	51-17243
C4328	285-0644-00			CAP., FXD, PLSTC:0.033UF,20%,600V	56289	410P33306
CR4151	152-0141-02			SEMICONV DEVICE:SILICON,30V,150MA	01295	1N4152R
CR4156	152-0141-02			SEMICONV DEVICE:SILICON,30V,150MA	01295	1N4152R
CR4211	152-0429-00			SEMICONV DEVICE:SILICON,5000V,10MA	14099	SA3282
CR4311	152-0429-00			SEMICONV DEVICE:SILICON,5000V,10MA	14099	SA3282
CR4313	152-0429-00			SEMICONV DEVICE:SILICON,5000V,10MA	14099	SA3282
CR4323	152-0429-00			SEMICONV DEVICE:SILICON,5000V,10MA	14099	SA3282
Q4145	151-0273-00	B010100	B020245	TRANSISTOR:SILICON,NPN	80009	151-0273-00
Q4145	151-0347-00	B020246	B069999	TRANSISTOR:SILICON,NPN	56289	2N5551
Q4145	151-0136-03	B070000		TRANSISTOR:SILICON,NPN,SEL	80009	151-0136-03
Q4149	151-0273-00	B010100	B020245	TRANSISTOR:SILICON,NPN	80009	151-0273-00
Q4149	151-0347-00	B020246	B069999	TRANSISTOR:SILICON,NPN	56289	2N5551
Q4149	151-0136-03	B070000		TRANSISTOR:SILICON,NPN,SEL	80009	151-0136-03
R4114	315-0106-00	B010100	B020231	RES., FXD, CMPSN:10M OHM,5%,0.25W	01121	CB1065
R4114	315-0125-00	B020232	B069999	RES., FXD, CMPSN:1.2M OHM,5%,0.25W	01121	CB1255
R4114	315-0625-00	B070000		RES., FXD, CMPSN:6.2M OHM,5%,0.25W	01121	CB6255
R4122	315-0470-00			RES., FXD, CMPSN:47 OHM,5%,0.25W	01121	CB4705
R4123	315-0470-00			RES., FXD, CMPSN:47 OHM,5%,0.25W	01121	CB4705
R4126	315-0225-00	B010100	B020231	RES., FXD, CMPSN:2.2M OHM,5%,0.25W	01121	CB2255
R4126	315-0155-00	B020232	B069999	RES., FXD, CMPSN:1.5M OHM,5%,0.25W	01121	CB1555
R4126	315-0474-00	B070000		RES., FXD, CMPSN:470K OHM,5%,0.25W	01121	CB4745
R4129	315-0475-00			RES., FXD, CMPSN:4.7M OHM,5%,0.25W	01121	CB4755
R4141	315-0472-00			RES., FXD, CMPSN:4.7K OHM,5%,0.25W	01121	CB4725
R4145	315-0105-00			RES., FXD, CMPSN:1M OHM,5%,0.25W	01121	CB1055
R4146	315-0472-00			RES., FXD, CMPSN:4.7K OHM,5%,0.25W	01121	CB4725
R4148	315-0105-00			RES., FXD, CMPSN:1M OHM,5%,0.25W	01121	CB1055
R4221	315-0475-00			RES., FXD, CMPSN:4.7M OHM,5%,0.25W	01121	CB4755
R4222	311-1257-00			RES., VAR, NONWIR:5M OHM,20%,0.50W	32997	3386F-T04-505
R4245	315-0102-00			RES., FXD, CMPSN:1K OHM,5%,0.25W	01121	CB1025
R4442	315-0475-00			RES., FXD, CMPSN:4.7M OHM,5%,0.25W	01121	CB4755
	-----			(OPTION 1 ONLY)		
T4241	120-0975-00	B010100	B069999	XFMR, PWR, SDN/SU:HIGH VOLTAGE POT CORE	80009	120-0975-00
T4241	120-0975-01	B070000		TRANSFORMER, RF:HIGH VOLTAGE POT CORE	80009	120-0975-01
VR4117	152-0247-00			SEMICONV DEVICE:ZENER,0.4W,150V,5%	04713	SZG275K1RL

Replaceable Electrical Parts—1503

Ckt No.	Tektronix Part No.	Serial/Model No. Eff	Dscont	Name & Description	Mfr Code	Mfr Part Number
A5	670-3513-00	B010100	B019999	CKT BOARD ASSY:CHART RECORDER LOGIC	80009	670-3513-00
A5	670-3513-01	B020000	B082958	CKT BOARD ASSY:CHART RECORDER LOGIC	80009	670-3513-01
A5	670-3513-02	B082959		CKT BOARD ASSY:CHART RECORDER LOGIC	80009	670-3513-02
C5116	283-0198-00			CAP., FXD, CER DI:0.22UF, 20%, 50V	72982	8121N083Z5U0224M
C5117	283-0054-00			CAP., FXD, CER DI:150PF, 5%, 200V	59660	855-535U2J0 151J
C5131	290-0524-00	B010100	B019999X	CAP., FXD, ELCTLT:4.7UF, 20%, 10V	90201	TDC475M010EL
C5159	283-0203-00			CAP., FXD, CER DI:0.47UF, 20%, 50V	72982	8131M058Z5U0474M
C5167	283-0004-00			CAP., FXD, CER DI:0.02UF, +80-20%, 150V	91418	SP203Z151-4R9
C5219	283-0111-00			CAP., FXD, CER DI:0.1UF, 20%, 50V	72982	8121-N088Z5U104M
C5249	283-0111-00			CAP., FXD, CER DI:0.1UF, 20%, 50V	72982	8121-N088Z5U104M
C5253	283-0154-00			CAP., FXD, CER DI:22PF, 5%, 50V	72982	8111B061C0G220J
C5263	283-0110-00			CAP., FXD, CER DI:0.005UF, +80-20%, 150V	56289	19C242B
C5266	283-0010-00			CAP., FXD, CER DI:0.05UF, +100-20%, 50V	56289	273C20
C5276	283-0346-00			CAP., FXD, CER DI:0.47UF, +80-20%, 100V	72982	8131-M100F474Z
CR5162	152-0141-02			SEMICONV DEVICE:SILICON, 30V, 150MA	01295	1N4152R
CR5243	152-0141-02			SEMICONV DEVICE:SILICON, 30V, 150MA	01295	1N4152R
CR5244	152-0141-02			SEMICONV DEVICE:SILICON, 30V, 150MA	01295	1N4152R
CR5245	152-0141-02			SEMICONV DEVICE:SILICON, 30V, 150MA	01295	1N4152R
CR5254	152-0141-02			SEMICONV DEVICE:SILICON, 30V, 150MA	01295	1N4152R
Q5112	151-1078-00	B010100	B019999	TRANSISTOR:SILICON, JFE, N-CHANNEL	17856	J2133
Q5112	151-1022-00	B020000		TRANSISTOR:FET, N-CHAN, SI, F1782, T0-18	80009	151-1022-00
Q5114	151-0301-00			TRANSISTOR:SILICON, PNP	27014	2N2907A
Q5144	151-0301-00			TRANSISTOR:SILICON, PNP	27014	2N2907A
Q5173	151-0126-00			TRANSISTOR:SILICON, NPN	04713	ST1046
Q5179	151-0301-00			TRANSISTOR:SILICON, PNP	27014	2N2907A
Q5226	151-0301-00			TRANSISTOR:SILICON, PNP	27014	2N2907A
Q5229	151-0301-00			TRANSISTOR:SILICON, PNP	27014	2N2907A
Q5237	151-0302-00			TRANSISTOR:SILICON, NPN	07263	S038487
Q5239	151-0302-00			TRANSISTOR:SILICON, NPN	07263	S038487
Q5266	151-0302-00			TRANSISTOR:SILICON, NPN	07263	S038487
Q5273	151-0301-00			TRANSISTOR:SILICON, PNP	27014	2N2907A
Q5277	151-0260-00			TRANSISTOR:SILICON, NPN	80009	151-0260-00
Q5279	151-0301-00			TRANSISTOR:SILICON, PNP	27014	2N2907A
R5112	315-0104-00			RES., FXD, CMPSN:100K OHM, 5%, 0.25W	01121	CB1045
R5116	315-0105-00			RES., FXD, CMPSN:1M OHM, 5%, 0.25W	01121	CB1055
R5118	316-0186-00			RES., FXD, CMPSN:18M OHM, 10%, 0.25W	01121	CB1861
R5119	315-0105-00			RES., FXD, CMPSN:1M OHM, 5%, 0.25W	01121	CB1055
R5121	315-0104-00			RES., FXD, CMPSN:100K OHM, 5%, 0.25W	01121	CB1045
R5122	315-0104-00			RES., FXD, CMPSN:100K OHM, 5%, 0.25W	01121	CB1045
R5126	315-0105-00			RES., FXD, CMPSN:1M OHM, 5%, 0.25W	01121	CB1055
R5128	315-0105-00			RES., FXD, CMPSN:1M OHM, 5%, 0.25W	01121	CB1055
R5130	321-0644-00			RES., FXD, FILM:100K OHM, 0.25%, 0.125W	91637	MFF1816C10002C
R5131	315-0335-00			RES., FXD, CMPSN:3.3M OHM, 5%, 0.25W	01121	CB3355
R5132	321-0756-03			RES., FXD, FILM:50K OHM, 0.25%, 0.125W	91637	MFF1816D50001C
R5134	321-0644-00			RES., FXD, FILM:100K OHM, 0.25%, 0.125W	91637	MFF1816C10002C
R5135	321-0756-03			RES., FXD, FILM:50K OHM, 0.25%, 0.125W	91637	MFF1816D50001C
R5136	321-0756-03			RES., FXD, FILM:50K OHM, 0.25%, 0.125W	91637	MFF1816D50001C
R5137	321-0756-03			RES., FXD, FILM:50K OHM, 0.25%, 0.125W	91637	MFF1816D50001C
R5138	321-0644-00			RES., FXD, FILM:100K OHM, 0.25%, 0.125W	91637	MFF1816C10002C
R5139	321-0644-00			RES., FXD, FILM:100K OHM, 0.25%, 0.125W	91637	MFF1816C10002C
R5141	315-0104-00			RES., FXD, CMPSN:100K OHM, 5%, 0.25W	01121	CB1045
R5148	315-0104-00			RES., FXD, CMPSN:100K OHM, 5%, 0.25W	01121	CB1045
R5155	315-0104-00			RES., FXD, CMPSN:100K OHM, 5%, 0.25W	01121	CB1045
R5158	315-0105-00			RES., FXD, CMPSN:1M OHM, 5%, 0.25W	01121	CB1055
R5161	315-0104-00			RES., FXD, CMPSN:100K OHM, 5%, 0.25W	01121	CB1045
R5163	315-0105-00			RES., FXD, CMPSN:1M OHM, 5%, 0.25W	01121	CB1055
R5166	315-0104-00			RES., FXD, CMPSN:100K OHM, 5%, 0.25W	01121	CB1045

Ckt No.	Tektronix Part No.	Serial/Model No. Eff	Dscont	Name & Description	Mfr Code	Mfr Part Number
R5167	315-0105-00			RES., FXD, CMPSN: 1M OHM, 5%, 0.25W	01121	CB1055
R5168	315-0105-00			RES., FXD, CMPSN: 1M OHM, 5%, 0.25W	01121	CB1055
R5171	315-0333-00			RES., FXD, CMPSN: 33K OHM, 5%, 0.25W	01121	CB3335
R5177	315-0102-00			RES., FXD, CMPSN: 1K OHM, 5%, 0.25W	01121	CB1025
R5178	315-0102-00			RES., FXD, CMPSN: 1K OHM, 5%, 0.25W	01121	CB1025
R5211	321-0318-02			RES., FXD, FILM: 20K OHM, 0.5%, 0.125W	91637	CMF55116D20001D
R5216	321-0306-01			RES., FXD, FILM: 15K OHM, 0.5%, 0.125W	91637	MFF1816G15001D
R5221	315-0104-00			RES., FXD, CMPSN: 100K OHM, 5%, 0.25W	01121	CB1045
R5222	315-0105-00			RES., FXD, CMPSN: 1M OHM, 5%, 0.25W	01121	CB1055
R5223	321-0345-00			RES., FXD, FILM: 38.3K OHM, 1%, 0.125W	91637	MFF1816G38301F
R5225	315-0104-00			RES., FXD, CMPSN: 100K OHM, 5%, 0.25W	01121	CB1045
R5229	315-0104-00			RES., FXD, CMPSN: 100K OHM, 5%, 0.25W	01121	CB1045
R5231	321-0756-03			RES., FXD, FILM: 50K OHM, 0.25%, 0.125W	91637	MFF1816D50001C
R5232	321-0644-00			RES., FXD, FILM: 100K OHM, 0.25%, 0.125W	91637	MFF1816C10002C
R5233	315-0473-00			RES., FXD, CMPSN: 47K OHM, 5%, 0.25W	01121	CB4735
R5234	321-0644-00			RES., FXD, FILM: 100K OHM, 0.25%, 0.125W	91637	MFF1816C10002C
R5235	321-0644-00			RES., FXD, FILM: 100K OHM, 0.25%, 0.125W	91637	MFF1816C10002C
R5236	315-0104-00			RES., FXD, CMPSN: 100K OHM, 5%, 0.25W	01121	CB1045
R5237	315-0104-00			RES., FXD, CMPSN: 100K OHM, 5%, 0.25W	01121	CB1045
R5246	315-0104-00			RES., FXD, CMPSN: 100K OHM, 5%, 0.25W	01121	CB1045
R5247	315-0566-00			RES., FXD, CMPSN: 56M OHM, 5%, 0.25W	01121	CB5665
R5248	315-0105-00			RES., FXD, CMPSN: 1M OHM, 5%, 0.25W	01121	CB1055
R5255	315-0104-00			RES., FXD, CMPSN: 100K OHM, 5%, 0.25W	01121	CB1045
R5259	315-0105-00			RES., FXD, CMPSN: 1M OHM, 5%, 0.25W	01121	CB1055
R5263	315-0105-00			RES., FXD, CMPSN: 1M OHM, 5%, 0.25W	01121	CB1055
R5266	315-0473-00			RES., FXD, CMPSN: 47K OHM, 5%, 0.25W	01121	CB4735
R5267	315-0104-00			RES., FXD, CMPSN: 100K OHM, 5%, 0.25W	01121	CB1045
R5268	315-0472-00			RES., FXD, CMPSN: 4.7K OHM, 5%, 0.25W	01121	CB4725
R5269	315-0104-00			RES., FXD, CMPSN: 100K OHM, 5%, 0.25W	01121	CB1045
R5275	315-0561-00			RES., FXD, CMPSN: 560 OHM, 5%, 0.25W	01121	CB5615
U5117	156-0686-00			MICROCIRCUIT, LI: OPNL AMPL, HIGH IMPEDANCE	02735	CA3130S
U5127	156-0525-00	B010100	B082958	MICROCIRCUIT, DI: DUAL J-K MASTER SLAVE F-F	80009	156-0525-00
U5127	156-0525-03	B082959		MICROCIRCUIT, DI: DUAL J-K MASTER SLAVE FF	80009	156-0525-03
U5147	156-0523-00			MICROCIRCUIT, DI: 7-STAGE BINARY COUNTER	80009	156-0523-00
U5156	156-0350-00	B010100	B082958	MICROCIRCUIT, DI: QUAD 2-INPUT NAND GATE	80009	156-0350-00
U5156	156-0350-02	B082959		MICROCIRCUIT, DI: QUAD 2 INPUT NAND GATE, SEL	80009	156-0350-02
U5166	156-0350-00	B010100	B082958	MICROCIRCUIT, DI: QUAD 2-INPUT NAND GATE	80009	156-0350-00
U5166	156-0350-02	B082959		MICROCIRCUIT, DI: QUAD 2 INPUT NAND GATE, SEL	80009	156-0350-02
U5227	156-0067-00	B010100	B072079	MICROCIRCUIT, LI: OPERATIONAL AMPLIFIER	02735	85145
U5227	156-0067-12	B072080		MICROCIRCUIT, LI: OPERATIONAL AMPLIFIER	01295	UA741CJG
U5252	156-0524-00			MICROCIRCUIT, DI: TRIPLE 3-INPUT NAND GATES	80009	156-0524-00

Replaceable Electrical Parts—1503

Ckt No.	Tektronix Part No.	Serial/Model No. Eff	Dscont	Name & Description	Mfr Code	Mfr Part Number
A6	670-3520-00	B010100	B020245	CKT BOARD ASSY:POWER	80009	670-3520-00
A6	670-3520-01	B020246	B082958	CKT BOARD ASSY:POWER	80009	670-3520-01
A6	670-3520-02	B082959		CKT BOARD ASSY:POWER	80009	670-3520-02
C6147	283-0177-00			CAP., FXD, CER DI: 1UF, +80-20%, 25V	56289	273C5
C6219	290-0114-00			CAP., FXD, ELCTLT: 47UF, 20%, 6V	56289	150D476X0006B2
C6224	283-0177-00			CAP., FXD, CER DI: 1UF, +80-20%, 25V	56289	273C5
C6226	283-0177-00			CAP., FXD, CER DI: 1UF, +80-20%, 25V	56289	273C5
C6228	290-0114-00			CAP., FXD, ELCTLT: 47UF, 20%, 6V	56289	150D476X0006B2
C6233	290-0527-00			CAP., FXD, ELCTLT: 15UF, 20%, 20V	90201	TDC156M020FL
C6243	290-0559-00			CAP., FXD, ELCTLT: 22UF, 20%, 35V	90201	TDC226M035WLG
C6246	290-0137-00			CAP., FXD, ELCTLT: 100UF, +75-15%, 30V	56289	109D107C7030T2
C6323	290-0425-00			CAP., FXD, ELCTLT: 100UF, 20%, 20V	90201	THF107M020P1G
C6326	290-0425-00			CAP., FXD, ELCTLT: 100UF, 20%, 20V	90201	THF107M020P1G
C6329	290-0425-00			CAP., FXD, ELCTLT: 100UF, 20%, 20V	90201	THF107M020P1G
C6336	290-0425-00			CAP., FXD, ELCTLT: 100UF, 20%, 20V	90201	THF107M020P1G
C6341	290-0137-00			CAP., FXD, ELCTLT: 100UF, +75-15%, 30V	56289	109D107C7030T2
C6342	283-0142-00	XB020232		CAP., FXD, CER DI: 0.0027UF, 5%, 200V	59660	875-571-Y5E0272J
C6415	290-0701-00			CAP., FXD, ELCTLT: 470UF, 40%, 16VDC	90201	TTX471U0161E1A3P
C6416	290-0134-00			CAP., FXD, ELCTLT: 22UF, 20%, 15V	56289	150D226X0015B2
C6426	290-0701-00			CAP., FXD, ELCTLT: 470UF, 40%, 16VDC	90201	TTX471U0161E1A3P
C6429	290-0425-00			CAP., FXD, ELCTLT: 100UF, 20%, 20V	90201	THF107M020P1G
C6443	290-0701-00			CAP., FXD, ELCTLT: 470UF, 40%, 16VDC	90201	TTX471U0161E1A3P
C6444	283-0107-00			CAP., FXD, CER DI: 51PF, 5%, 200V	72982	8121B232COG0510J
C6447	283-0111-00			CAP., FXD, CER DI: 0.1UF, 20%, 50V	72982	8121-N088Z5U104M
C6451	283-0047-00			CAP., FXD, CER DI: 270PF, 5%, 500V	72982	0831522Z5D00271J
C6455	283-0115-00	XB020246		CAP., FXD, CER DI: 47PF, 5%, 200V	59660	805-519-COG0470J
C6515	283-0000-00			CAP., FXD, CER DI: 0.001UF, +100-0%, 500V	59660	831-519-Z5U-102P
C6525	290-0425-00			CAP., FXD, ELCTLT: 100UF, 20%, 20V	90201	THF107M020P1G
C6527	290-0164-00			CAP., FXD, ELCTLT: 1UF, +50-10%, 150V	56289	500D105F150BA7
C6529	290-0658-00			CAP., FXD, ELCTLT: 4UF, +50-10%, 200V	56289	600D405F200KD4
C6551	283-0077-00			CAP., FXD, CER DI: 330PF, 5%, 500V	59660	831-500B331J
CR6139	152-0400-00			SEMICONV DEVICE: SILICON, 400V, 1A	80009	152-0400-00
CR6157	152-0488-00			SEMICONV DEVICE: SILICON, 200V, 1500MA	04713	SDA317
CR6234	152-0141-02			SEMICONV DEVICE: SILICON, 30V, 150MA	01295	1N4152R
CR6247	152-0141-02			SEMICONV DEVICE: SILICON, 30V, 150MA	01295	1N4152R
CR6346	152-0400-00			SEMICONV DEVICE: SILICON, 400V, 1A	80009	152-0400-00
CR6347	152-0141-02			SEMICONV DEVICE: SILICON, 30V, 150MA	01295	1N4152R
CR6414	152-0400-00			SEMICONV DEVICE: SILICON, 400V, 1A	80009	152-0400-00
CR6438	152-0400-00			SEMICONV DEVICE: SILICON, 400V, 1A	80009	152-0400-00
CR6439	152-0400-00			SEMICONV DEVICE: SILICON, 400V, 1A	80009	152-0400-00
CR6441	152-0141-02			SEMICONV DEVICE: SILICON, 30V, 150MA	01295	1N4152R
CR6442	152-0141-02			SEMICONV DEVICE: SILICON, 30V, 150MA	01295	1N4152R
CR6446	152-0400-00	B010100	B020245X	SEMICONV DEVICE: SILICON, 400V, 1A	80009	152-0400-00
CR6448	152-0141-02			SEMICONV DEVICE: SILICON, 30V, 150MA	01295	1N4152R
CR6452	152-0141-02			SEMICONV DEVICE: SILICON, 30V, 150MA	01295	1N4152R
CR6534	152-0400-00			SEMICONV DEVICE: SILICON, 400V, 1A	80009	152-0400-00
CR6536	152-0586-00			SEMICONV DEVICE: SILICON, 600V, 500MA	14936	RGP10J-011
CR6537	152-0586-00			SEMICONV DEVICE: SILICON, 600V, 500MA	14936	RGP10J-011
CR6546	152-0141-02			SEMICONV DEVICE: SILICON, 30V, 150MA	01295	1N4152R
CR6551	152-0141-02			SEMICONV DEVICE: SILICON, 30V, 150MA	01295	1N4152R
F6112	159-0128-00			FUSE, CARTRIDGE: 2A, 125V, 5 SEC	75915	273002
F6113	159-0128-00			FUSE, CARTRIDGE: 2A, 125V, 5 SEC	75915	273002
F6122	159-0128-00			FUSE, CARTRIDGE: 2A, 125V, 5 SEC	75915	273002
F6123	159-0128-00			FUSE, CARTRIDGE: 2A, 125V, 5 SEC	75915	273002
L6344	108-0598-00			COIL, RF: 200UH	80009	108-0598-00
L6423	108-0598-00			COIL, RF: 200UH	80009	108-0598-00
L6428	108-0598-00			COIL, RF: 200UH	80009	108-0598-00

Ckt No.	Tektronix Part No.	Serial/Model No. Eff	Dscont	Name & Description	Mfr Code	Mfr Part Number
L6532	108-0598-00			COIL, RF: 200UH	80009	108-0598-00
L6538	108-0598-00			COIL, RF: 200UH	80009	108-0598-00
Q6143	151-0508-00			TRANSISTOR: UJT, SI, 2N6027, TO-98	03508	2N6027
Q6155	151-0506-00			SCR: SILICON	03508	C106B2X283
Q6227	151-0302-00			TRANSISTOR: SILICON, NPN	07263	S038487
Q6241	151-0188-00			TRANSISTOR: SILICON, PNP	04713	SPS6868K
Q6244	151-0188-00			TRANSISTOR: SILICON, PNP	04713	SPS6868K
Q6331	151-0302-00			TRANSISTOR: SILICON, NPN	07263	S038487
Q6349	151-0390-00			TRANSISTOR: SILICON, NPN	04713	SPS3414
Q6357	151-0302-00			TRANSISTOR: SILICON, NPN	07263	S038487
Q6427	151-0301-00			TRANSISTOR: SILICON, PNP	27014	2N2907A
Q6435	151-0352-00			TRANSISTOR: SILICON, NPN	03508	X44C282
Q6445	151-0424-00			TRANSISTOR: SILICON, NPN	04713	SPS8246
Q6458	151-0424-00			TRANSISTOR: SILICON, NPN	04713	SPS8246
Q6547	151-0302-00			TRANSISTOR: SILICON, NPN	07263	S038487
Q6548	151-0301-00			TRANSISTOR: SILICON, PNP	27014	2N2907A
Q6549	151-0301-00			TRANSISTOR: SILICON, PNP	27014	2N2907A
Q6552	151-0302-00			TRANSISTOR: SILICON, NPN	07263	S038487
Q6557	151-0302-00			TRANSISTOR: SILICON, NPN	07263	S038487
R6131	308-0463-00			RES., FXD, WW: 0.3 OHM, 1%, 3W	91637	RS2B-KR3000F
R6132	315-0102-00			RES., FXD, CMPSN: 1K OHM, 5%, 0.25W	01121	CB1025
R6133	315-0362-00			RES., FXD, CMPSN: 3.6K OHM, 5%, 0.25W	01121	CB3625
R6134	315-0272-00			RES., FXD, CMPSN: 2.7K OHM, 5%, 0.25W	01121	CB2725
R6135	315-0154-00			RES., FXD, CMPSN: 150K OHM, 5%, 0.25W	01121	CB1545
R6147	315-0272-00			RES., FXD, CMPSN: 2.7K OHM, 5%, 0.25W	01121	CB2725
R6148	315-0101-00			RES., FXD, CMPSN: 100 OHM, 5%, 0.25W	01121	CB1015
R6149	315-0361-00			RES., FXD, CMPSN: 360 OHM, 5%, 0.25W	01121	CB3615
R6214	321-0289-00			RES., FXD, FILM: 10K OHM, 1%, 0.125W	91637	MFF1816G10001F
R6215	321-0260-00			RES., FXD, FILM: 4.99K OHM, 1%, 0.125W	91637	MFF1816G49900F
R6222	315-0821-00	B010100	B029999	RES., FXD, CMPSN: 820 OHM, 5%, 0.25W	01121	CB8215
R6222	315-0181-00	B030000		RES., FXD, CMPSN: 180 OHM, 5%, 0.25W	01121	CB1815
R6223	315-0202-00	B010100	B029999	RES., FXD, CMPSN: 2K OHM, 5%, 0.25W	01121	CB2025
R6223	315-0821-00	B030000	B030499	RES., FXD, CMPSN: 820 OHM, 5%, 0.25W	01121	CB8215
R6223	315-0431-00	B030500		RES., FXD, CMPSN: 430 OHM, 5%, 0.25W	01121	CB4315
R6225	321-0289-00			RES., FXD, FILM: 10K OHM, 1%, 0.125W	91637	MFF1816G10001F
R6231	321-0289-00			RES., FXD, FILM: 10K OHM, 1%, 0.125W	91637	MFF1816G10001F
R6235	315-0391-00			RES., FXD, CMPSN: 390 OHM, 5%, 0.25W	01121	CB3915
R6254	304-0391-00			RES., FXD, CMPSN: 390 OHM, 10%, 1W	01121	GB3911
R6346	315-0101-00	B010100	B020245	RES., FXD, CMPSN: 100 OHM, 5%, 0.25W	01121	CB1015
R6346	315-0471-00	B020246		RES., FXD, CMPSN: 470 OHM, 5%, 0.25W	01121	CB4715
R6356	315-0753-00	B010100	B020245	RES., FXD, CMPSN: 75K OHM, 5%, 0.25W	01121	CB7535
R6356	315-0563-00	B020246		RES., FXD, CMPSN: 56K OHM, 5%, 0.25W	01121	CB5635
R6358	311-1268-00			RES., VAR, NONWIR: 10K OHM, 10%, 0.50W	32997	3329P-L58-103
R6413	321-0352-00	B010100	B020231	RES., FXD, FILM: 45.3K OHM, 1%, 0.125W	91637	MFF1816G45301F
R6413	321-0332-00	B020232		RES., FXD, FILM: 28K OHM, 1%, 0.125W	91637	MFF1816G28001F
R6424	315-0103-00			RES., FXD, CMPSN: 10K OHM, 5%, 0.25W	01121	CB1035
R6426	315-0101-00			RES., FXD, CMPSN: 100 OHM, 5%, 0.25W	01121	CB1015
R6444	307-0103-00			RES., FXD, CMPSN: 2.7 OHM, 5%, 0.25W	01121	CB27G5
R6445	315-0104-00			RES., FXD, CMPSN: 100K OHM, 5%, 0.25W	01121	CB1045
R6447	315-0101-00			RES., FXD, CMPSN: 100 OHM, 5%, 0.25W	01121	CB1015
R6449	315-0513-00			RES., FXD, CMPSN: 51K OHM, 5%, 0.25W	01121	CB5135
R6451	315-0104-00			RES., FXD, CMPSN: 100K OHM, 5%, 0.25W	01121	CB1045
R6453	315-0513-00			RES., FXD, CMPSN: 51K OHM, 5%, 0.25W	01121	CB5135
R6454	315-0433-00			RES., FXD, CMPSN: 43K OHM, 5%, 0.25W	01121	CB4335
R6455	315-0473-00			RES., FXD, CMPSN: 47K OHM, 5%, 0.25W	01121	CB4735
R6456	315-0222-00			RES., FXD, CMPSN: 2.2K OHM, 5%, 0.25W	01121	CB2225

Replaceable Electrical Parts—1503

Ckt No.	Tektronix Part No.	Serial/Model No. Eff	Dscont	Name & Description	Mfr Code	Mfr Part Number
R6457	315-0104-00			RES., FXD, CMPSN:100K OHM, 5%, 0.25W	01121	CB1045
R6459	315-0204-00			RES., FXD, CMPSN:200K OHM, 5%, 0.25W	01121	CB2045
R6513	321-0346-00	B010100	B020231	RES., FXD, FILM:39.2K OHM, 1%, 0.125W	91637	MFF1816G39201F
R6513	321-0332-00	B020232		RES., FXD, FILM:28K OHM, 1%, 0.125W	91637	MFF1816G28001F
R6514	311-1268-00			RES., VAR, NONWIR:10K OHM, 10%, 0.50W	32997	3329P-L58-103
R6517	316-0156-00			RES., FXD, CMPSN:15M OHM, 10%, 0.25W	01121	CB1561
R6518	321-0260-00			RES., FXD, FILM:4.99K OHM, 1%, 0.125W	91637	MFF1816G49900F
R6538	315-0433-00			RES., FXD, CMPSN:43K OHM, 5%, 0.25W	01121	CB4335
R6539	315-0102-00			RES., FXD, CMPSN:1K OHM, 5%, 0.25W	01121	CB1025
R6544	315-0243-00			RES., FXD, CMPSN:24K OHM, 5%, 0.25W	01121	CB2435
R6545	315-0473-00			RES., FXD, CMPSN:47K OHM, 5%, 0.25W	01121	CB4735
R6548	315-0104-00			RES., FXD, CMPSN:100K OHM, 5%, 0.25W	01121	CB1045
R6549	315-0154-00			RES., FXD, CMPSN:150K OHM, 5%, 0.25W	01121	CB1545
R6553	315-0223-00			RES., FXD, CMPSN:22K OHM, 5%, 0.25W	01121	CB2235
R6554	315-0223-00			RES., FXD, CMPSN:22K OHM, 5%, 0.25W	01121	CB2235
R6557	315-0224-00			RES., FXD, CMPSN:220K OHM, 5%, 0.25W	01121	CB2245
R6558	315-0103-00	B010100	B020245	RES., FXD, CMPSN:10K OHM, 5%, 0.25W	01121	CB1035
R6558	315-0102-00	B020246		RES., FXD, CMPSN:1K OHM, 5%, 0.25W	01121	CB1025
T6535	120-0976-00			XFMR, FLYBACK:POT CORE	80009	120-0976-00
U6138	156-0067-00	B010100	B072079	MICROCIRCUIT, LI:OPERATIONAL AMPLIFIER	02735	85145
U6138	156-0067-12	B072080		MICROCIRCUIT, LI:OPERATIONAL AMPLIFIER	01295	UA741CJG
U6222	156-0067-00	B010100	B072079	MICROCIRCUIT, LI:OPERATIONAL AMPLIFIER	02735	85145
U6222	156-0067-12	B072080		MICROCIRCUIT, LI:OPERATIONAL AMPLIFIER	01295	UA741CJG
U6236	156-0067-00	B010100	B072079	MICROCIRCUIT, LI:OPERATIONAL AMPLIFIER	02735	85145
U6236	156-0067-12	B072080		MICROCIRCUIT, LI:OPERATIONAL AMPLIFIER	01295	UA741CJG
U6515	156-0067-00	B010100	B072079	MICROCIRCUIT, LI:OPERATIONAL AMPLIFIER	02735	85145
U6515	156-0067-12	B072080		MICROCIRCUIT, LI:OPERATIONAL AMPLIFIER	01295	UA741CJG
VR6134	152-0243-00			SEMICONV DEVICE:ZENER, 0.4W, 15V, 5%	14552	TD3810983
VR6235	152-0278-00			SEMICONV DEVICE:ZENER, 0.4W, 3V, 5%	04713	SZG35009K20
VR6252	152-0278-00			SEMICONV DEVICE:ZENER, 0.4W, 3V, 5%	04713	SZG35009K20
VR6253	152-0127-00			SEMICONV DEVICE:ZENER, 0.4W, 7.5V, 5%	04713	SZG35009K2
VR6318	152-0265-00			SEMICONV DEVICE:ZENER, 0.4W, 24V, 5%	04713	SZG35009K8
VR6417	152-0195-00			SEMICONV DEVICE:ZENER, 0.4W, 5.1V, 5%	04713	SZ11755
VR6419	152-0175-00			SEMICONV DEVICE:ZENER, 0.4W, 5.6V, 5%	04713	SZG35008
VR6427	152-0195-00			SEMICONV DEVICE:ZENER, 0.4W, 5.1V, 5%	04713	SZ11755
VR6459	152-0306-00			SEMICONV DEVICE:ZENER, 0.4W, 9.1V, 5%	15238	Z5409

Ckt No.	Tektronix Part No.	Serial/Model No. Eff	Dscont	Name & Description	Mfr Code	Mfr Part Number
A7	670-3865-00 -----	B010100	B082958	CKT BOARD ASSY:X-Y PLUG IN (016-0606-00 ONLY)	80009	670-3865-00
A7	670-3865-01 -----	B082959		CKT BOARD ASSY:X-Y PLUG IN (016-0606-00 ONLY)	80009	670-3865-01
C7132	283-0059-00			CAP.,FXD,CER DI:1UF,+80-20%,25V	72982	8131N031Z5U0105Z
C7232	283-0059-00			CAP.,FXD,CER DI:1UF,+80-20%,25V	72982	8131N031Z5U0105Z
CR7247	152-0141-02			SEMICON D DEVICE:SILICON,30V,150MA	01295	1N4152R
Q7242	151-0302-00			TRANSISTOR:SILICON,NPN	07263	S038487
R7122	321-0301-00			RES.,FXD,FILM:13.3K OHM,1%,0.125W	91637	MFF1816G13301F
R7129	321-0288-00			RES.,FXD,FILM:9.76K OHM,1%,0.125W	91637	MFF1816G97600F
R7138	321-0335-00			RES.,FXD,FILM:30.1K OHM,1%,0.125W	91637	MFF1816G30101F
R7146	315-0103-00			RES.,FXD,CMPSN:10K OHM,5%,0.25W	01121	CB1035
R7224	315-0223-00			RES.,FXD,CMPSN:22K OHM,5%,0.25W	01121	CB2235
R7225	311-1559-00			RES.,VAR,NONWIR:10K OHM,20%,0.50W	73138	91-81-0
R7234	315-0113-00			RES.,FXD,CMPSN:11K OHM,5%,0.25W	01121	CB1135
R7244	315-0104-00			RES.,FXD,CMPSN:100K OHM,5%,0.25W	01121	CB1045
R7245	315-0103-00			RES.,FXD,CMPSN:10K OHM,5%,0.25W	01121	CB1035

Replaceable Electrical Parts—1503

Ckt No.	Tektronix Part No.	Serial/Model No. Eff	Dscont	Name & Description	Mfr Code	Mfr Part Number
A8	670-5634-00 -----			CKT BOARD ASSY:CABLE VP FACTOR (OPTION 1 ONLY)	80009	670-5634-00
R1356A	321-0193-03			RES.,FXD,FILM:1K OHM,0.25%,0.125W	91637	MFF1816D10000C
R1356B	321-0612-03			RES.,FXD,FILM:500 OHM,0.25%,0.125W	91637	MFF1816D500ROC
R1356C	321-0612-03			RES.,FXD,FILM:500 OHM,0.25%,0.125W	91637	MFF1816D500ROC
R1356D	321-0612-03			RES.,FXD,FILM:500 OHM,0.25%,0.125W	91637	MFF1816D500ROC
R1356E	321-0612-03			RES.,FXD,FILM:500 OHM,0.25%,0.125W	91637	MFF1816D500ROC
R1356F	321-0612-03			RES.,FXD,FILM:500 OHM,0.25%,0.125W	91637	MFF1816D500ROC
R1356G	321-0612-03			RES.,FXD,FILM:500 OHM,0.25%,0.125W	91637	MFF1816D500ROC
R1356H	321-0612-03			RES.,FXD,FILM:500 OHM,0.25%,0.125W	91637	MFF1816D500ROC
R1356J	321-0612-03			RES.,FXD,FILM:500 OHM,0.25%,0.125W	91637	MFF1816D500ROC
R1356K	321-0612-03			RES.,FXD,FILM:500 OHM,0.25%,0.125W	91637	MFF1816D500ROC
R1357A	321-0097-07			RES.,FXD,FILM:100 OHM,0.1%,0.125W	24546	NE55E1000B
R1357B	321-0097-07			RES.,FXD,FILM:100 OHM,0.1%,0.125W	24546	NE55E1000B
R1357C	321-0097-07			RES.,FXD,FILM:100 OHM,0.1%,0.125W	24546	NE55E1000B
R1357D	321-0097-07			RES.,FXD,FILM:100 OHM,0.1%,0.125W	24546	NE55E1000B
R1357E	321-0097-07			RES.,FXD,FILM:100 OHM,0.1%,0.125W	24546	NE55E1000B
R1357F	321-0097-07			RES.,FXD,FILM:100 OHM,0.1%,0.125W	24546	NE55E1000B
R1357G	321-0097-07			RES.,FXD,FILM:100 OHM,0.1%,0.125W	24546	NE55E1000B
R1357H	321-0097-07			RES.,FXD,FILM:100 OHM,0.1%,0.125W	24546	NE55E1000B
R1357J	321-0097-07			RES.,FXD,FILM:100 OHM,0.1%,0.125W	24546	NE55E1000B
R1357K	321-0097-07			RES.,FXD,FILM:100 OHM,0.1%,0.125W	24546	NE55E1000B
S1356	260-1918-00			SWITCH,ROTARY:DISTANCE CAL,8 POSITION	81073	51SP2201208N
S1357	260-1919-00			SWITCH,ROTARY:DISTANCE CAL,11 POS	81073	51SP3001111N
A9	670-6592-00	XB090000		CKT BOARD ASSY:POWER FUSE JACK	80009	670-6592-00
F9100	159-0124-00	XB090000		FUSE,WIRE LEAD:3A,125V	75915	272003

Ckt No.	Tektronix Part No.	Serial/Model No. Eff	Dscont	Name & Description	Mfr Code	Mfr Part Number
CHASSIS PARTS						
BT0369	016-0595-00	B010100	B089999	BATTERY SET:	80009	016-0595-00
BT0369	016-0595-01	B090000		BATTERY SET:	80009	016-0595-01
C0380	283-0279-00			CAP., FXD, CER DI:0.001UF, 20%, 3000V	59660	878-530 Y5S0102M
C0390	283-0279-00			CAP., FXD, CER DI:0.001UF, 20%, 3000V	59660	878-530 Y5S0102M
CRO282	150-1040-01			LAMP, LED:W/LEADS & DIODE HOLDER	80009	150-1040-01
F0401	159-0029-00	B010100	B049999	FUSE, CARTRIDGE:3AG, 0.3A, 250V, SLOW-BLOW	71400	MDL3/10
F0401	159-0032-00	B050000		FUSE, CARTRIDGE:3AG, 0.5A, 250V, SLOW-BLOW	71400	MDL 1/2
F0401	159-0054-00	B010100	B049999	FUSE, CARTRIDGE:3AG, 0.15A, 250V, SLOW-BLOW (OPTION 6 ONLY)	71400	MDL 15/100
F0401	159-0029-01	B050000		FUSE, CARTRIDGE:BUSSMAN ONLY (OPTION 6 ONLY)	71400	MDL3/10
F0491	159-0029-00	B010100	B049999	FUSE, CARTRIDGE:3AG, 0.3A, 250V, SLOW-BLOW	71400	MDL3/10
F0491	159-0032-00	B050000		FUSE, CARTRIDGE:3AG, 0.5A, 250V, SLOW-BLOW	71400	MDL 1/2
F0491	159-0054-00	B010100	B049999	FUSE, CARTRIDGE:3AG, 0.15A, 250V, SLOW-BLOW (OPTION 6 ONLY)	71400	MDL 15/100
F0491	159-0029-01	B050000		FUSE, CARTRIDGE:BUSSMAN ONLY (OPTION 6 ONLY)	71400	MDL3/10
F0491	159-0172-00	XB083230		FUSE, CARTRIDGE:TYPE C, 13 AMP (OPTION A2 ONLY)	33096	PB1267
L0234	108-0671-01			COIL, TUBE DEFLE:	80009	108-0671-01
M0171	149-0031-00	B010100	B029999	METER, BTRY LVL:0-350UA, 15%, 0.50 DIA, SCALE	24138	P-202
M0171	149-0044-05	B030000		METER, BAT LEVEL:1MA, 345 OHMS, 0.5 DIA W/CONN	80009	149-0044-05
R0151	311-1806-00	B010100	B079999	RES., VAR, NONWIR:500 OHM, 20%, 1W	12697	381S-CM40942
R0151	311-2010-01	B080000	B093425	RES., VAR, WW:PNL, 500 OHM, 5%, 1W, W/SW	80009	311-2010-01
R0151	311-2131-00	B093426		RES., VAR, NONWIR:PNL, 500 OHM, 5%, 1W, W/4SPT	80009	311-2131-00
R0165	315-0102-00			RES., FXD, CMPSN:1K OHM, 5%, 0.25W	01121	CB1025
R0251A, B	311-0678-00			RES., VAR, NONWIR:2 X 50K OHM, 10%, 0.50W	71590	BA211-008
R0252	315-0473-00			RES., FXD, CMPSN:47K OHM, 5%, 0.25W	01121	CB4735
R0262	315-0104-00			RES., FXD, CMPSN:100K OHM, 5%, 0.25W	01121	CB1045
R0263	311-0160-00			RES., VAR, NONWIR:50K OHM, 10%, 0.50W	12697	381-CM30918
R0271	311-1707-00	B010100	B039999	RES., VAR, WW:5K OHM, 5%, 1.5W (OPTION 5 ONLY)	32997	3610S-420-502
R0271	311-1707-02	B040000		RES., VAR, WW:PNL, 5K OHM, 5%, 1.5W, W/KNOB (OPTION 5 ONLY)	80009	311-1707-02
R0271	311-1800-00	B010100	B039999	RES., VAR, WW:PNL, 5K OHM, 5%, 1.5W	32997	3610S-514-502
R0271	311-1800-02	B040000		RES., VAR, WW:PNL, 5K OHM, 5%, 1.5W, W/KNOB	80009	311-1800-02
R0352	315-0473-00			RES., FXD, CMPSN:47K OHM, 5%, 0.25W	01121	CB4735
R0432	311-0690-01	B010100	B020329	RES., VAR, NONWIR:5M OHM, 0.50W	0000M	OBD
R0432	311-1905-00	B020330		RES., VAR, NONWIR:PNL, 5M OHM, 20%, 0.50W	12697	CM412712
R0442	311-0690-01	B010100	B020329	RES., VAR, NONWIR:5M OHM, 0.50W (NOT USED IN OPTION 1)	0000M	OBD
R0442	311-1906-00	B020330		RES., VAR, NONWIR:PNL, 5M OHM, 20%, 0.25W (NOT USED IN OPTION 1)	12697	CM41713
R0472	311-0091-00			RES., VAR, NONWIR:1K OHM, 10%, 0.50W (NOT USED IN OPTION 1)	01121	W-3083E
R2126	311-1005-00			RES., VAR, NONWIR:15K OHM, 10%, 0.50W	12697	382-CM40952
S0151	260-1923-00			SWITCH, PUSH:4PST, 0.4VA, 28V	01121	17M814
S0165	260-0834-00			SWITCH, TOGGLE:DPDT, 5A, 125VAC, 0.25-40 THD	09353	U21-SHZQE
S0481A, B	260-1727-00			SWITCH, TOGGLE:DPDT, 0.4VA AND 20V MAX	09353	7215 SYZ(B)E
S1215	263-1118-00			SW CAM ACTR AS:FEET/DIV	80009	263-1118-00
S1343	263-0013-00			SWITCH, PB ASSY:3 LATCHING, 100MM, W/DETENT	80009	263-0013-00
S1356	260-1918-00			SWITCH, ROTARY:DISTANCE CAL, 8 POSITION (OPTION 1 ONLY)	81073	51SP2201208N

Replaceable Electrical Parts—1503

Ckt No.	Tektronix Part No.	Serial/Model No. Eff	Dscont	Name & Description	Mfr Code	Mfr Part Number
S1357	260-1919-00			SWITCH, ROTARY: DISTANCE CAL, 11 POS	81073	51SP3001111N
S1357	-----			(OPTION 1 ONLY)		
S1624	263-0010-00			SWITCH PB ASSY: 1 PUSH, 7.5MM, W/2 CONTACTS	80009	263-0010-00
S1625	263-0011-00			SWITCH, PB ASSY: 1 PUSH, 10 MM, W/4 CONTACTS	80009	263-0011-00
S2126	263-1125-00			SW CAM ACTR AS: FEET/DIV	80009	263-1125-00
T0389	120-0978-00			XFMR, PWR, STPDN:	80009	120-0978-00
V0235	154-0667-02			ELECTRON TUBE: CRT, P-31	80009	154-0667-02
V0235	154-0067-13	XB020321		ELECTRON TUBE: CRT, P-7	80009	154-0667-03
	-----			(OPTION 76 ONLY)		

DIAGRAMS AND CIRCUIT BOARD ILLUSTRATIONS

Symbols

Graphic symbols and class designation letters are based on ANSI Standard Y32.2-1975.

Logic symbology is based on ANSI Y32.14-1973 in terms of positive logic. Logic symbols depict the logic function performed and may differ from the manufacturer's data.

The overline on a signal name indicates that the signal performs its intended function when it is in the low state.

Abbreviations are based on ANSI Y1.1-1972.

Other ANSI standards that are used in the preparation of diagrams by Tektronix, Inc. are:

- Y14.15, 1966 Drafting Practices.
- Y14.2, 1973 Line Conventions and Lettering.
- Y10.5, 1968 Letter Symbols for Quantities Used in Electrical Science and Electrical Engineering.

American National Standard Institute
1430 Broadway
New York, New York 10018

Component Values

Electrical components shown on the diagrams are in the following units unless noted otherwise:

Capacitors = Values one or greater are in picofarads (pF).
Values less than one are in microfarads (μ F).

Resistors = Ohms (Ω).

— The information and special symbols below may appear in this manual. —

Assembly Numbers and Grid Coordinates

Each assembly in the instrument is assigned an assembly number (e.g., A20). The assembly number appears on the circuit board outline on the diagram, in the title for the circuit board component location illustration, and in the lookup table for the schematic diagram and corresponding component locator illustration. The Replaceable Electrical Parts list is arranged by assemblies in numerical sequence; the components are listed by component number *(see following illustration for constructing a component number).

The schematic diagram and circuit board component location illustration have grids. A lookup table with the grid coordinates is provided for ease of locating the component. Only the components illustrated on the facing diagram are listed in the lookup table. When more than one schematic diagram is used to illustrate the circuitry on a circuit board, the circuit board illustration may only appear opposite the first diagram on which it was illustrated; the lookup table will list the diagram number of other diagrams that the circuitry of the circuit board appears on.

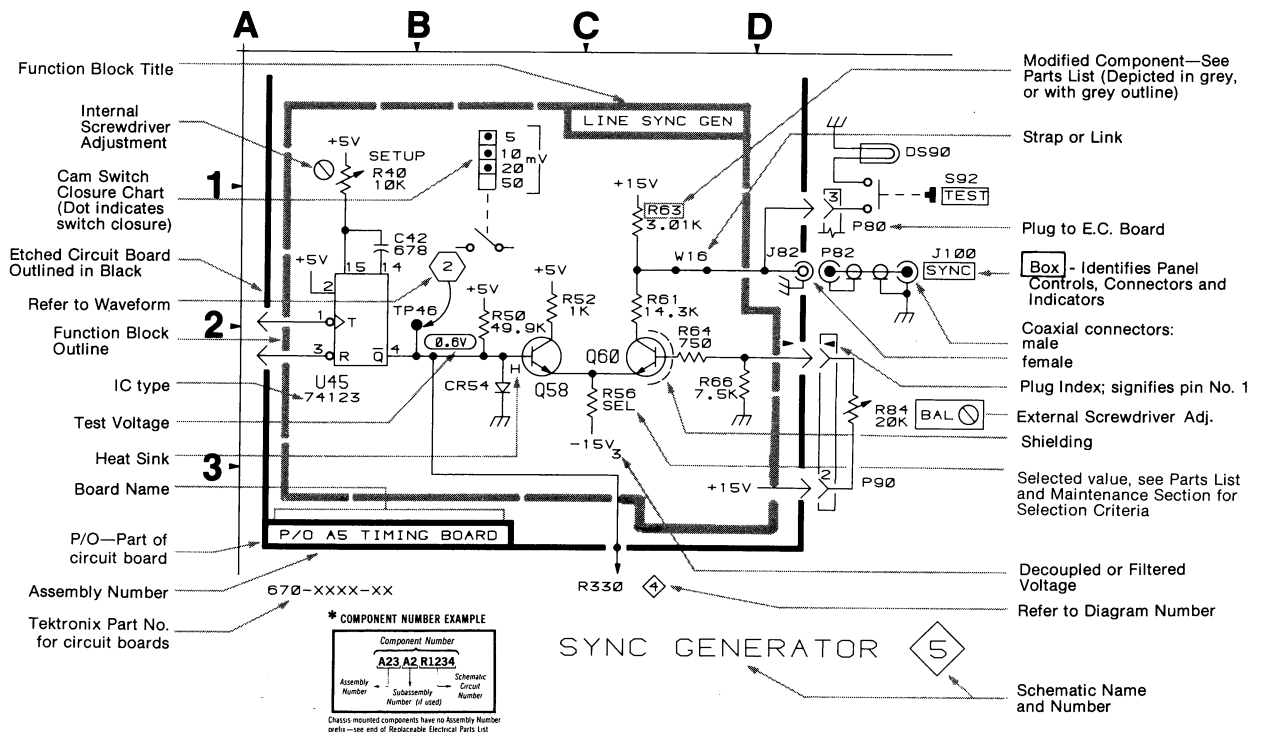

1 | 2 | 3 | 4 | 5 | 6 | 7 | 8 | 9 | 10

A
B
C
D
E
F
G
H

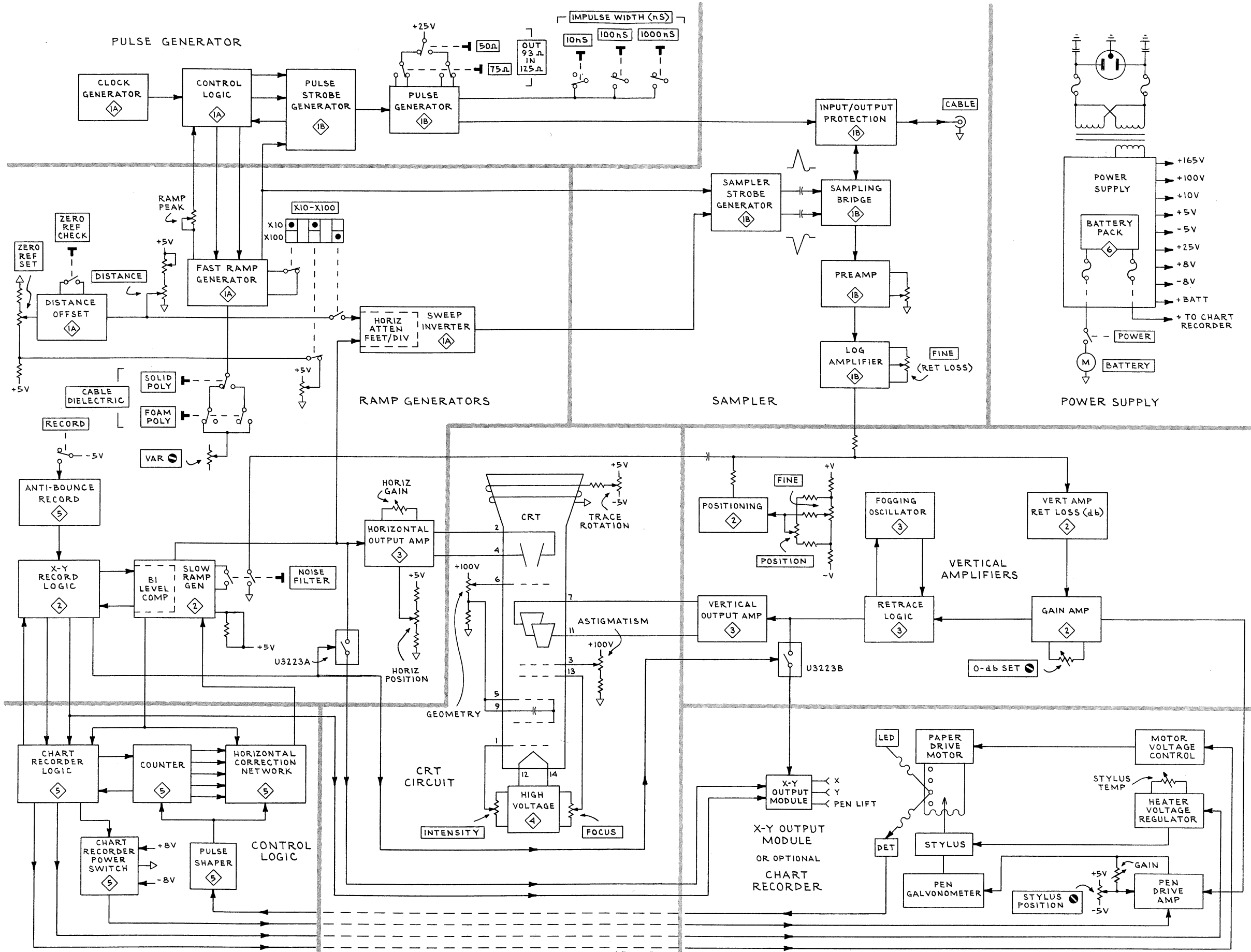

1503

REV B FEB 1980
1865-25

Block Diagram

1503 BLOCK DIAGRAM

CKT NO	GRID LOC	CKT NO	GRID LOC
C1143	D10	R1229	B4
C1153	C7	R1249	E6
C1227	E7	R1256	E9
C1238	E6	R1257	E10
C1243	D9	R1258	E9
C1249	E5	R1313	D4
C1257	E9	R1314	D4
C1321	D4	R1317	E2
C1324	A7	R1319	D4
C1331	B7	R1328	A7
C1422	D4	R1336	B7
C1434	E7	R1337	E7
C1459	G6	R1338	E7
C1563	G4	R1353	C9
C1565	G5	R1354	E6
C1762	F3	R1355	C8
C1765	E3	R1356	C8
		R1357	C9
CR1358	E5	R1414	E2
CR1463	G6	R1421	C1
CR1561	H6	R1424	D1
CR1563	G3	R1462	G6
CR1564	G4	R1477	G5
		R1562	G3
L1155	C10	R1563	G4
L1162	B7	R1576	G5
		R1663	F10
Q1142	D7	R1664	G4
Q1235	D6	R1669	E3
Q1236	E6	R1676	F10
Q1246	E7	R1761	F3
Q1247	E9	R1762	H6
Q1332	E7	R1765	E3
Q1565	G4		
Q1571	G5	S0151	D1
		S1156	C9
R0151	D1	S1252	D9
R0271	E1	S1215F	A3
R0472	C10	S1215R	A6
R1115	B2		
R1117	B2	TP1312	F5
R1118	B3		
R1127	C6	U1219A	D5
R1132	C7	U1219B	C4
R1135	D7	U1663A	F3
R1137	C6	U1663B	G3
R1147	D9	U1663C	E5
R1148	D7	U1663D	G5
R1158	C10	U1667A	H3
R1216	C6	U1667B	G3
R1218	C4	U1667C	E3
R1227	B3	U1667D	E4
R1228	B3		

1 | 2 | 3 | 4 | 5 | 6 | 7 | 8 | 9 | 10

A
B
C
D
E
F
G
H

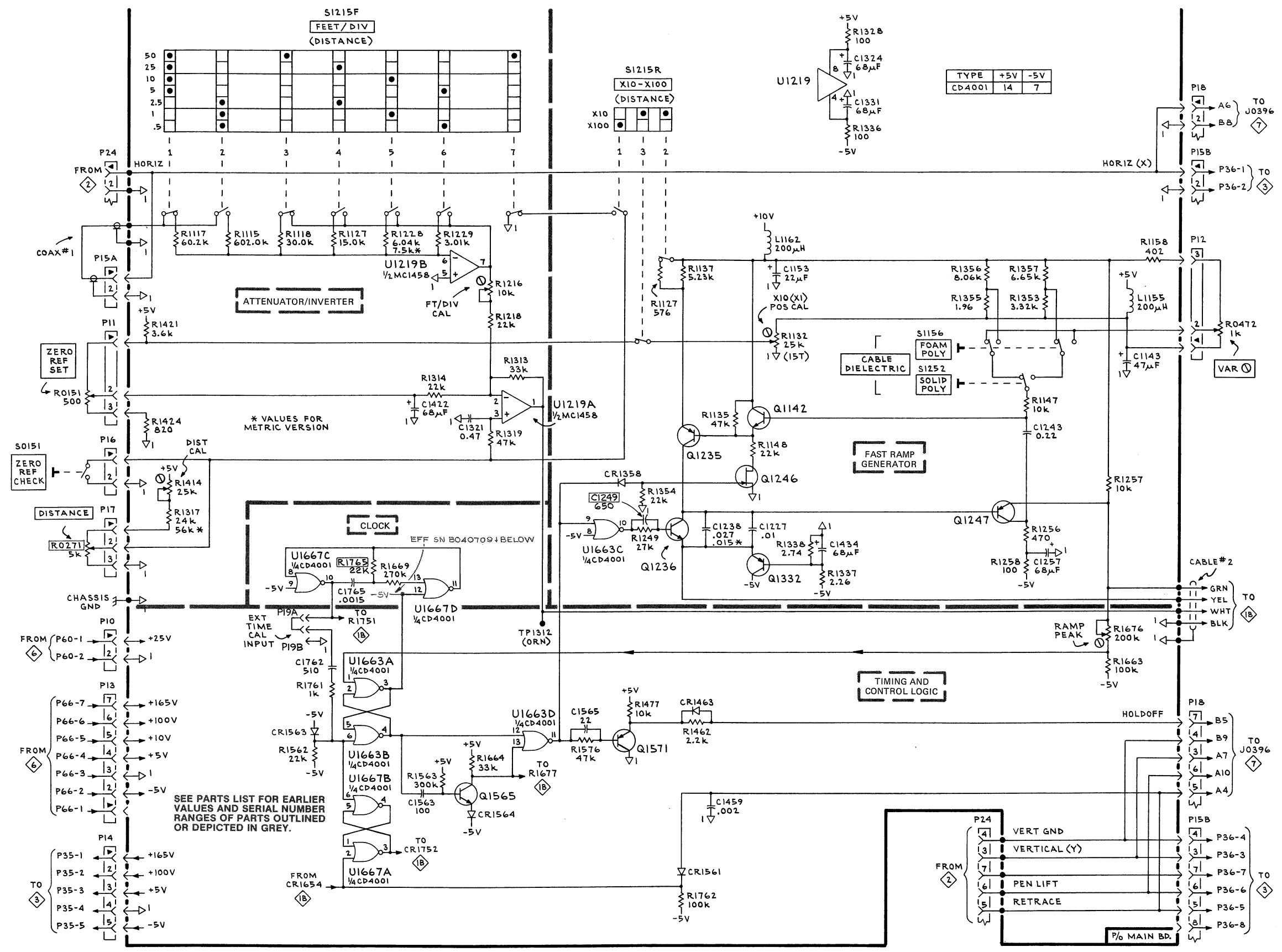

TIME BASE GENERATOR 1

CKT NO	GRID LOC	CKT NO	GRID LOC	CKT NO	GRID LOC
C1358	D15	L1433	A15	R1651	B12
C1447	B16	L1441	B15	R1655	B11
C1456	A13	L1449	A17	R1661	B11
C1503	H16	L1541	C15	R1672	F12
C1505	G16	L1546	D15	R1673	E15
C1508	H15	L1555	A12	R1674	E15
C1525	A15	L1753	C11	R1677	F15
C1531	B15	L1774	D18	R1683	G12
C1534	C15			R1687	E18
C1536	A17	Q1435	B15	R1688	E17
C1548	A13	Q1436	B16	R1692	G18
C1554	A12	Q1551	B13	R1693	G17
C1556	A13	Q1556	A13	R1694	G17
C1558	A11	Q1558	A12	R1701	G18
C1574	E11	Q1559	A11	R1724	C17
C1577	E12	Q1573	F11	R1725	C17
C1578	D16	Q1575	F11	R1731	C17
C1585	G14	Q1578	E12	R1733	C19
C1586	E12	Q1588	G12	R1734	C18
C1593	A15	Q1593	G13	R1743	B19
C1595	G15	Q1594	G15	R1751	B18
C1596	G13	Q1637	B17	R1752	B13
C1601	G19	Q1657	B13	R1754	B11
C1605	G16	Q1658	B11	R1755	B11
C1607	G16	Q1678	E15	R1773	F15
C1647	C20	Q1772	F15	R1774	F15
C1648	B20	Q1775	E15	R1781	E16
C1654	B11	R1406	H15	R1782	E16
C1673	E13	R1431	B16	R1783	E17
C1677	F15	R1436	A15	R1784	E18
C1686	E16	R1457	A13	R1785	E17
C1687	E17	R1486	F11	R1791	E18
C1697	F17	R1496	G13	R1793	G18
C1698	G17	R1502	H15	R1796	G18
C1701	F17	R1506	G16	R2126	H20
C1706	G18	R1507	H15	S1624	B/C17
C1715	B20	R1508	G15	S1625	B/C17
C1741	C18	R1509	G15	S1343A	C14/15
C1742	C19	R1532	B16	S1343B	C14/15
C1743	B19	R1533	B16	S1343C	B14/15
C1775	F16	R1543	B13		
C1783	E17	R1544	B13	T1686	E16
C1793	G18	R1545	A13		
		R1547	B17	TP1587	F11
CR1432	B15	R1552	A13	TP1687	D17
CR1433	A15	R1557	B12	TP1782	F17
CR1434	B15	R1577	C11	U1503	H15
CR1556	A12	R1582	F11	U1695A	G17
CR1557	A12	R1584	E12	U1695B	G19
CR1558	A11	R1587	D15	U1795	G18
CR1572	E12	R1588	F12		
CR1574	E11	R1589	G12	VR1649	B19
CR1581	F11	R1592	G13		
CR1582	F11	R1597	G14		
CR1639	C19	R1599	F16		
CR1647	B19	R1602	G16		
CR1648	B19	R1603	G20		
CR1654	B12	R1604	F16		
CR1659	B11	R1606	F18		
CR1673	E12	R1608	G20		
CR1688	E17	R1633	B17		
CR1689	E18	R1634	B17		
CR1696	E17	R1635	B17		
CR1735	B20	R1641	B17		
CR1752	B13	R1643	A17		
CR1755	B11	R1646	C20		
CR1792	E17				

VERT AMP/SLOW RAMP
COMPONENTS

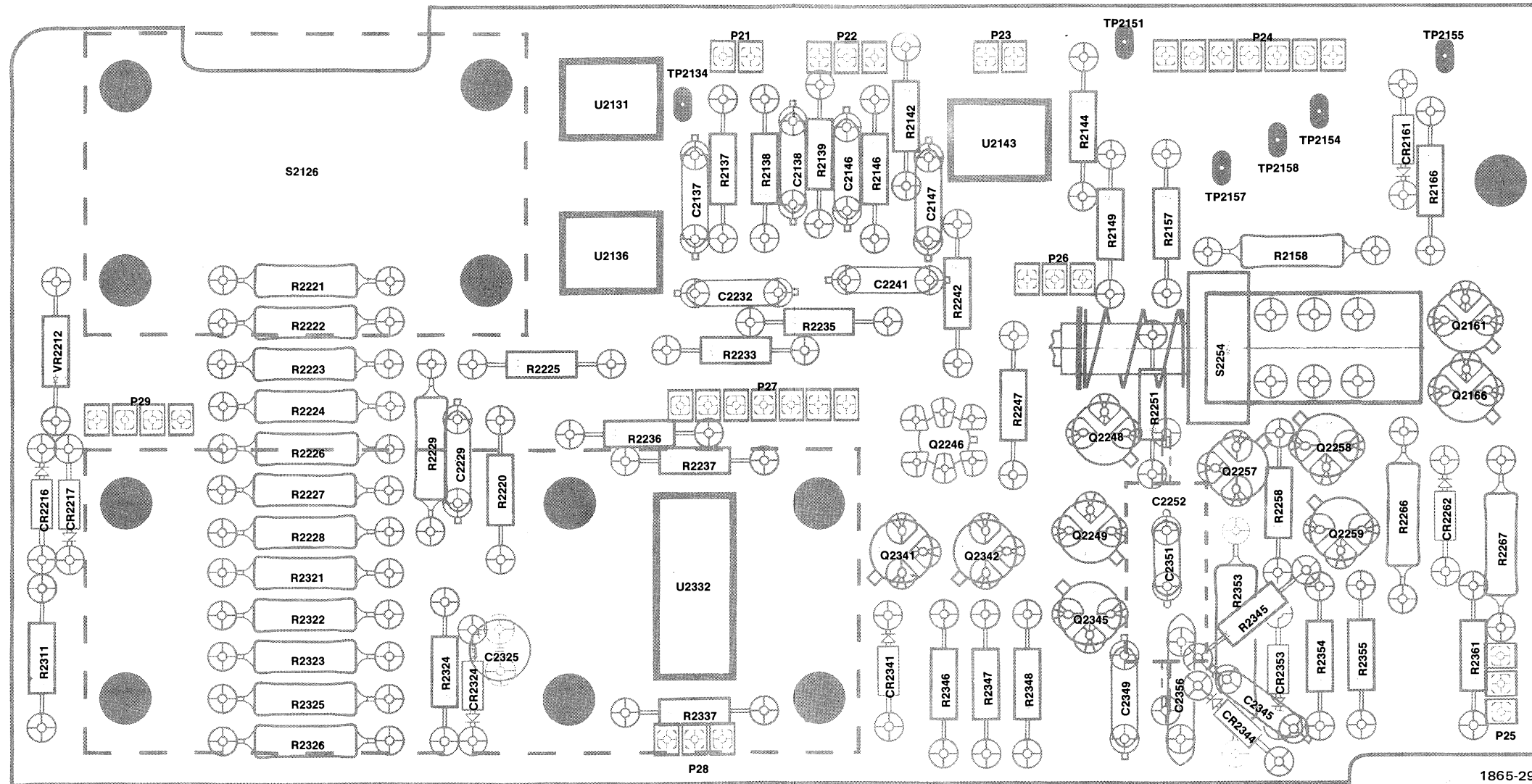

Vertical Amplifier/Slow Ramp Board

REV A FEB 1980

CKT NO	GRID LOC	CKT NO	GRID LOC
C2137	B3		
C2138	A2	R2354	G9
C2146	A2	R2355	H9
C2147	B2	R2361	G5
C2158	G5		
C2229	E2	S0481A	A10
C2232	E2	S2126	A5
C2241	C2	S2254	F2
C2325	C6		
C2349	G4	U2131	A2
C2351	F4	U2136	B3
C2352	F7	U2143	B8
C2356	F6	U2332	D6,E7
CR2159	G4	VR2212	H2
CR2216	H2		
CR2217	H2		
CR2262	G6		
CR2324	C6		
CR2341	D6		
CR2358	D6		
M0171	H1		
Q2161	G5		
Q2166	G5		
Q2246A	G6		
Q2246B	G6		
Q2248	F7		
Q2249	F7		
Q2257	F8		
Q2258	G8		
Q2259	G9		
Q2341	G3		
Q2342	B3		
Q2345	G4		
R0251A	A1		
R0251B	A1		
R0252	A1		
R0262	A1		
R0263	C9		
R0352	B1		
R2137	B2		
R2138	B2		
R2139	A2		
R2142	C8		
R2144	B7		
R2146	B2		
R2149	D8		
R2157	G4		
R2158	G5		
R2220	E3		
R2221	C4		
R2222	C3		
R2223	C5		
R2224	C6		
R2225	D2		
R2226	C7		
R2227	C7		
R2228	B7		
R2229	B4		
R2233	B7		
R2235	E2		
R2236	E7		
R2237	D7		
R2242	G3		
R2247	F7		
R2251	F8		
R2258	H9		
R2266	B6		
R2267	G5		
R2311	H2		
R2321	B7		
R2322	B6		
R2323	B5		
R2324	C6		
R2325	B5		
R2326	B4		
R2337	D7		
R2346	F8		
R2347	F7		
R2348	F8		
R2353	G2		

A
B
C
D
E
F
G
H

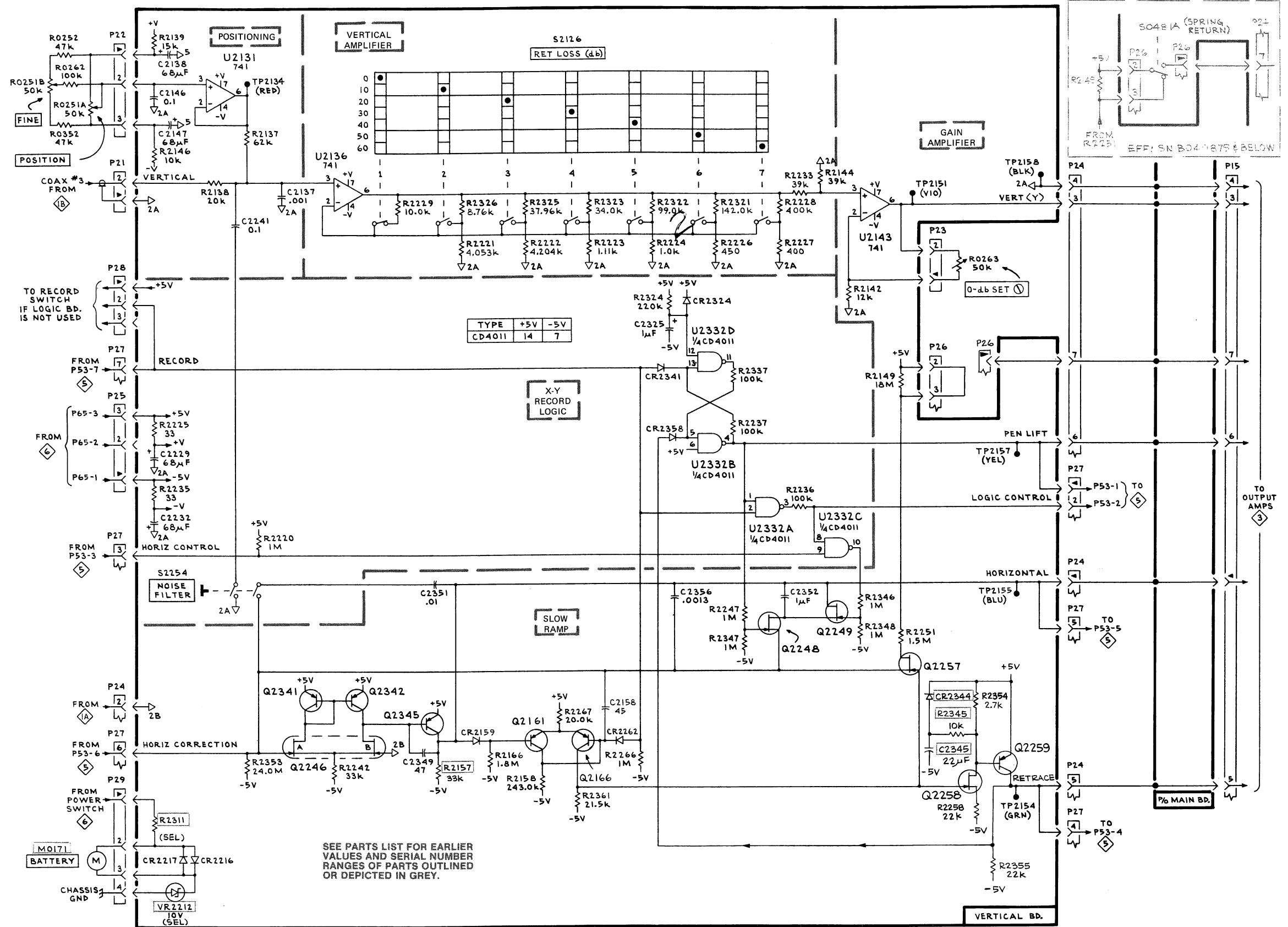

OUTPUT AMP & HIGH VOLTAGE
COMPONENTS

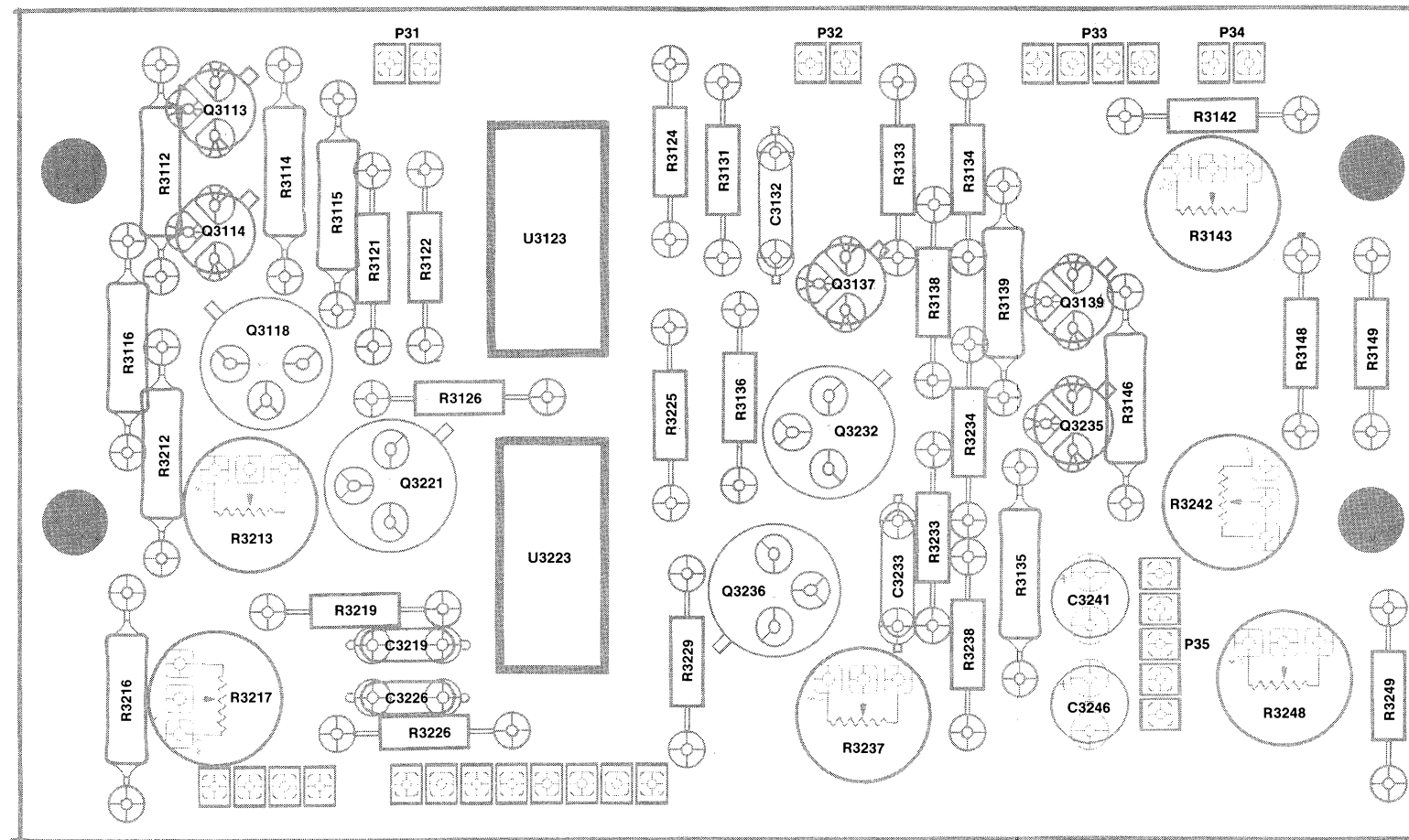

1865-31

Output Amplifier Board

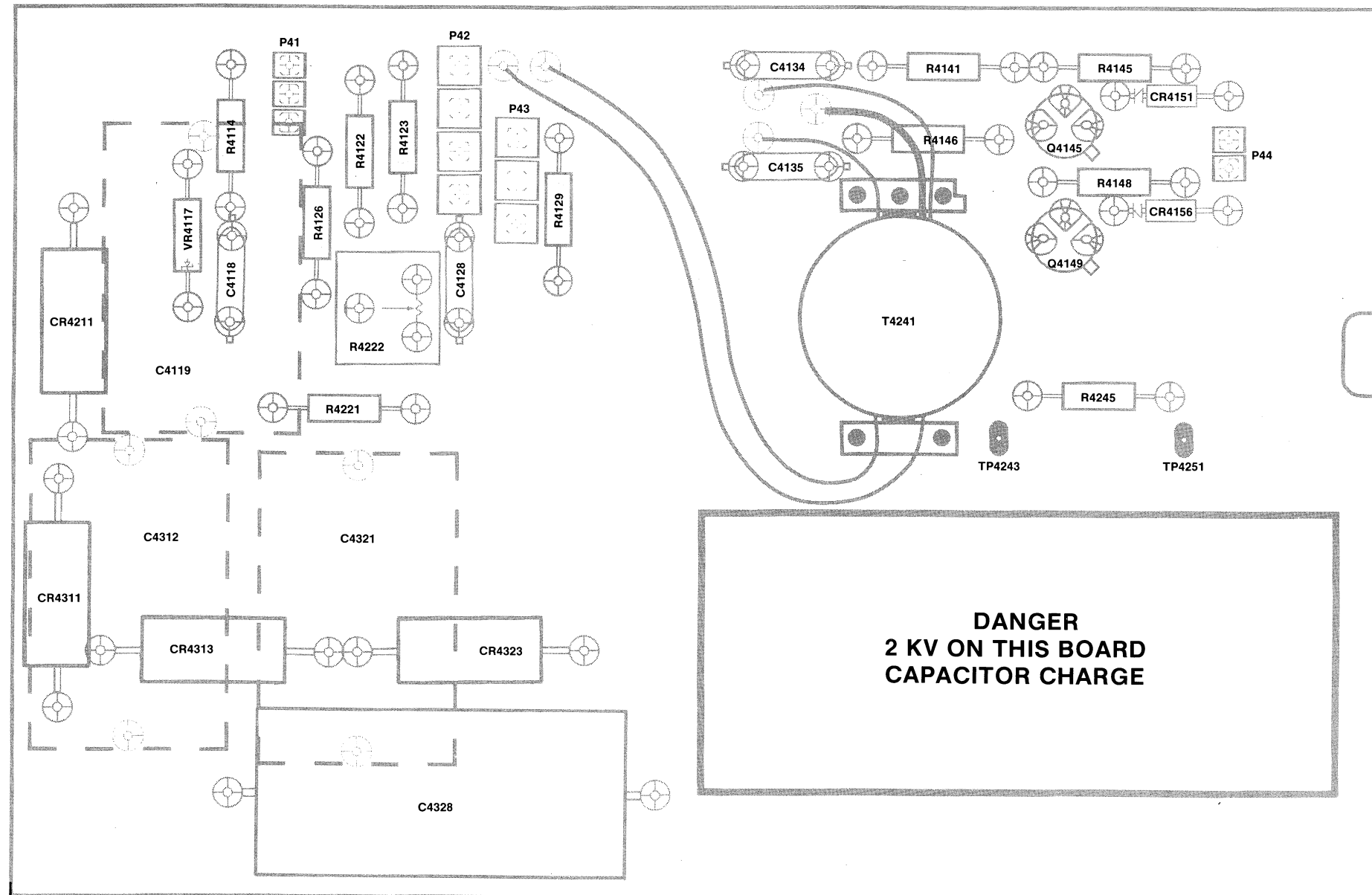

1865-32

High Voltage Board

CKT NO	GRID LOC	CKT NO	GRID LOC
C3132	E3	R4114	G6
C3219	B2	R4122	H6
C3226	D2	R4123	H6
C3233	D6	R4126	G6
C3241	A1	R4129	G6
C3246	A1	R4141	H2
		R4145	H2
C4118	G5	R4146	G2
C4119	G5	R4148	G2
C4128	H6	R4221	F6
C4134	H2	R4222	G6
C4135	G2	R4245	G3
C4312	H4		
C4321	G4		
C4328	H3	T4241	G3
CR4151	H2	TP4243	G4
CR4156	G2	TP4251	G4
CR4211	G5		
CR4311	G5	U3123	E1,E3
CR4313	G4	U3223	C2,D4
CR4323	G4		
		V0235	B9
L0234	B9		
P0230	G9		
Q3113	C5		
Q3114	C6		
Q3118	B6		
Q3137	E2		
Q3139	E5		
Q3221	B6		
Q3232	D6		
Q3235	E6		
Q3236	D6		
Q4145	H2		
Q4149	G2		
R0432	F7		
R0442	G7		
R3112	B5		
R3114	C6		
R3115	C5		
R3116	B6		
R3121	A6		
R3122	A6		
R3124	E3		
R3126	B7		
R3131	E3		
R3133	C6		
R3134	D6		
R3135	E5		
R3136	E2		
R3138	E3		
R3139	E6		
R3142	B10		
R3143	B10		
R3146	E5		
R3148	F10		
R3149	F10		
R3212	B6		
R3213	B7		
R3216	B6		
R3217	B6		
R3219	B2		
R3225	D2		
R3226	D2		
R3229	E1		
R3233	D6		
R3234	E6		
R3237	E2		
R3238	E6		
R3242	F10		
R3248	C10		
R3249	D10		

A
B
C
D
E
F
G
H

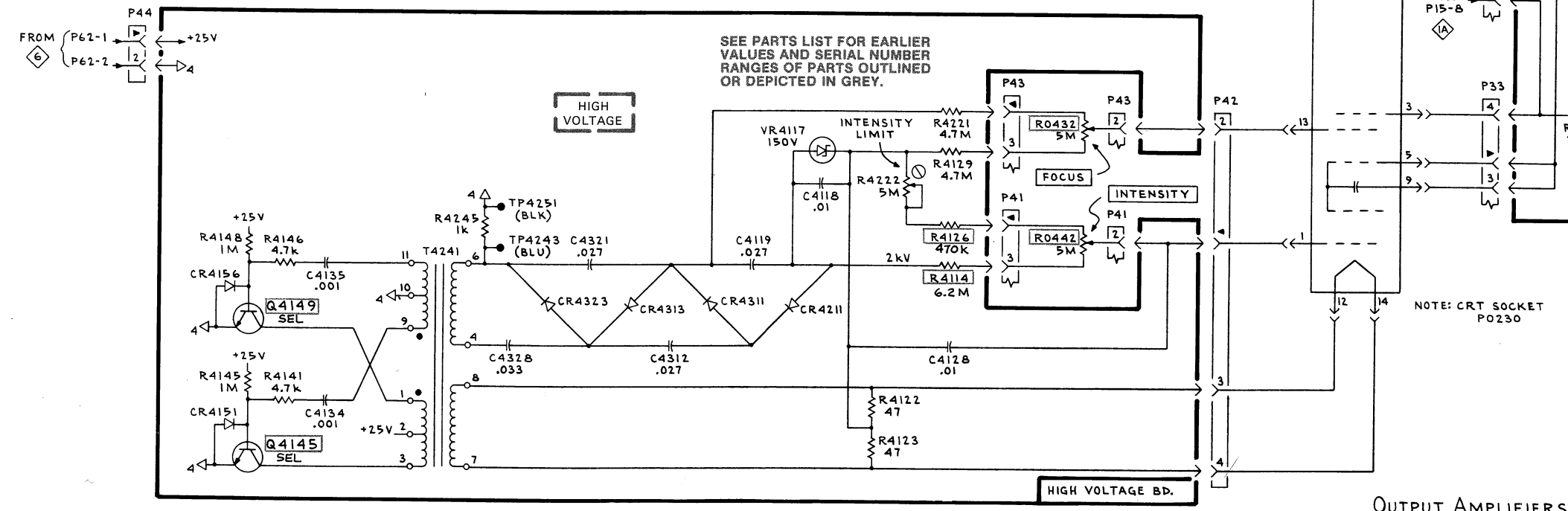
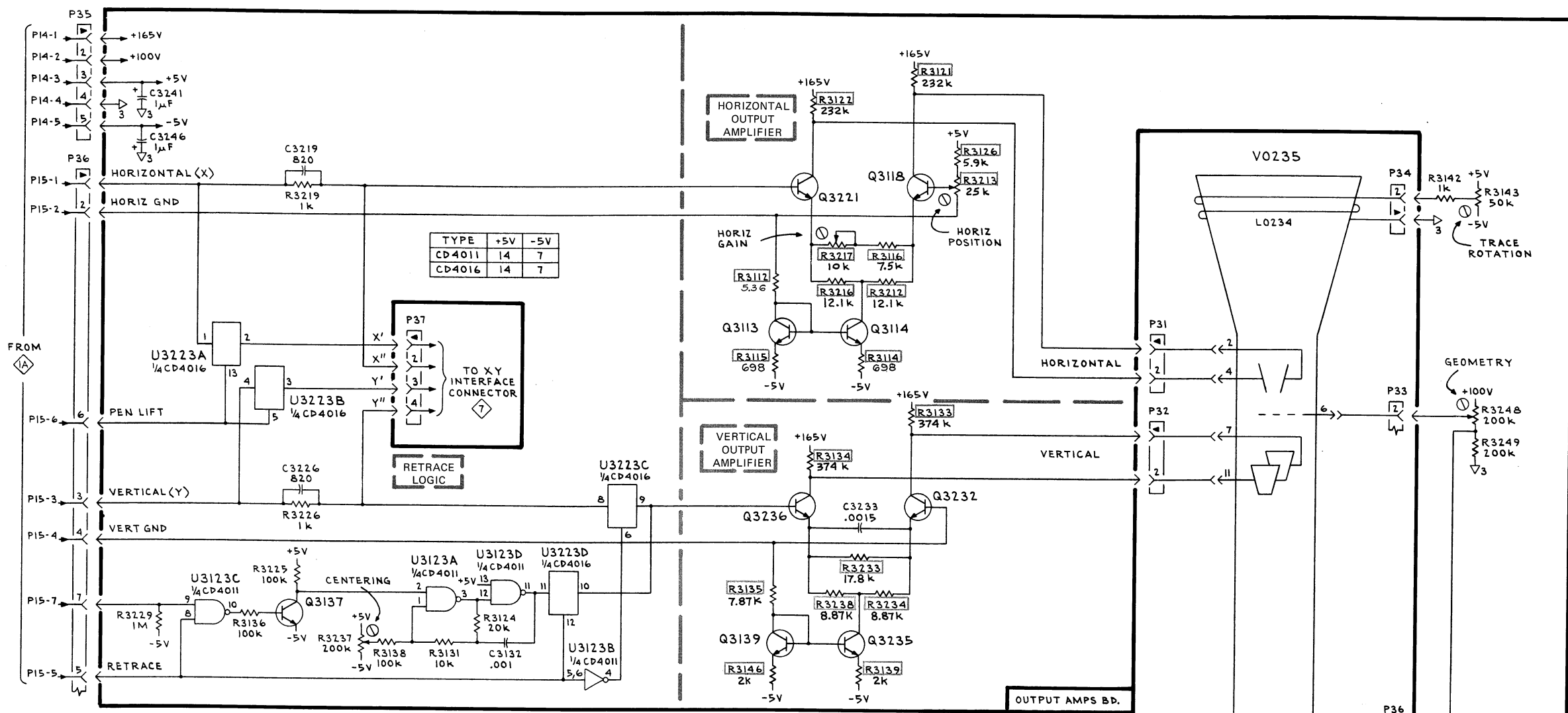

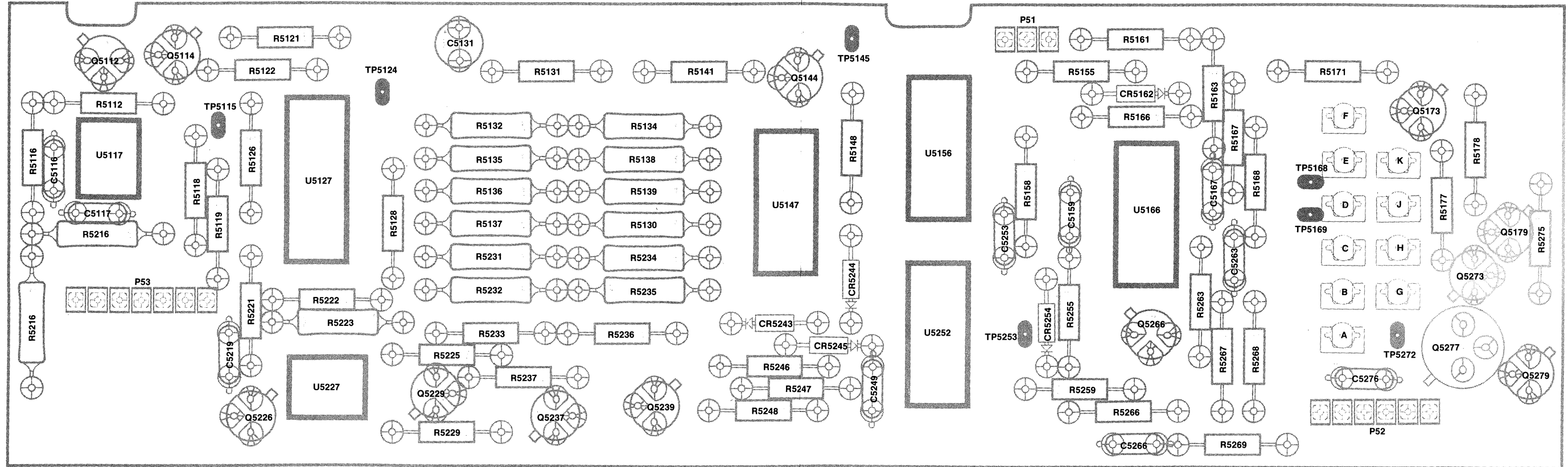

Logic Board

CKT NO	GRID LOC	CKT NO	GRID LOC
C5116	B5	R5259	E7
C5117	B6	R5263	A3
C5131	G7	R5266	E8
C5159	A5	R5267	A2
C5167	A4	R5268	A2
C5219	F2	R5269	A2
C5249	E7	R5275	H9
C5253	F6		
C5263	A3	S0481B	D1
C5266	A2		
C5276	A2	TP5115	B8
		TP5124	F5
CR5162	A4	TP5145	A6
CR5243	E7	TP5168	G9
CR5244	E6	TP5169	E9
CR5245	E6	TP5253	A7
CR5254	A6	TP5272	A2
Q5112	F8	U5117	B6
Q5114	G7	U5127	G5
Q5144	E5	U5147	C4
Q5173	G8	U5156	H2,E6
Q5179	G9	U5166	A3,A5
Q5226	F7	U5227	B3
Q5229	F7	U5252	D5,E8
Q5237	F6		
Q5239	G8		
Q5266	E8		
Q5273	H8		
Q5277	H9		
Q5279	H8		
R5112	B7		
R5116	B5		
R5118	B8		
R5119	G4		
R5121	G6		
R5122	G7		
R5126	G4		
R5128	G5		
R5130	C5		
R5131	B4		
R5132	C6		
R5134	C5		
R5135	C6		
R5136	C6		
R5137	C6		
R5138	C5		
R5139	C5		
R5141	E5		
R5148	D6		
R5155	H2		
R5158	E7		
R5161	H2		
R5163	A4		
R5166	A4		
R5167	A5		
R5168	A3		
R5171	G8		
R5177	G8		
R5178	G9		
R5211	B3		
R5216	B3		
R5221	F2		
R5222	G4		
R5223	B4		
R5225	F6		
R5229	F9		
R5231	D6		
R5232	D6		
R5233	G8		
R5234	D5		
R5235	D5		
R5236	F5		
R5237	F6		
R5246	E6		
R5247	E7		
R5248	E6		
R5255	A5		

I | 2 | 3 | 4 | 5 | 6 | 7 | 8 | 9 | 10

A
B
C
D
E
F
G
H

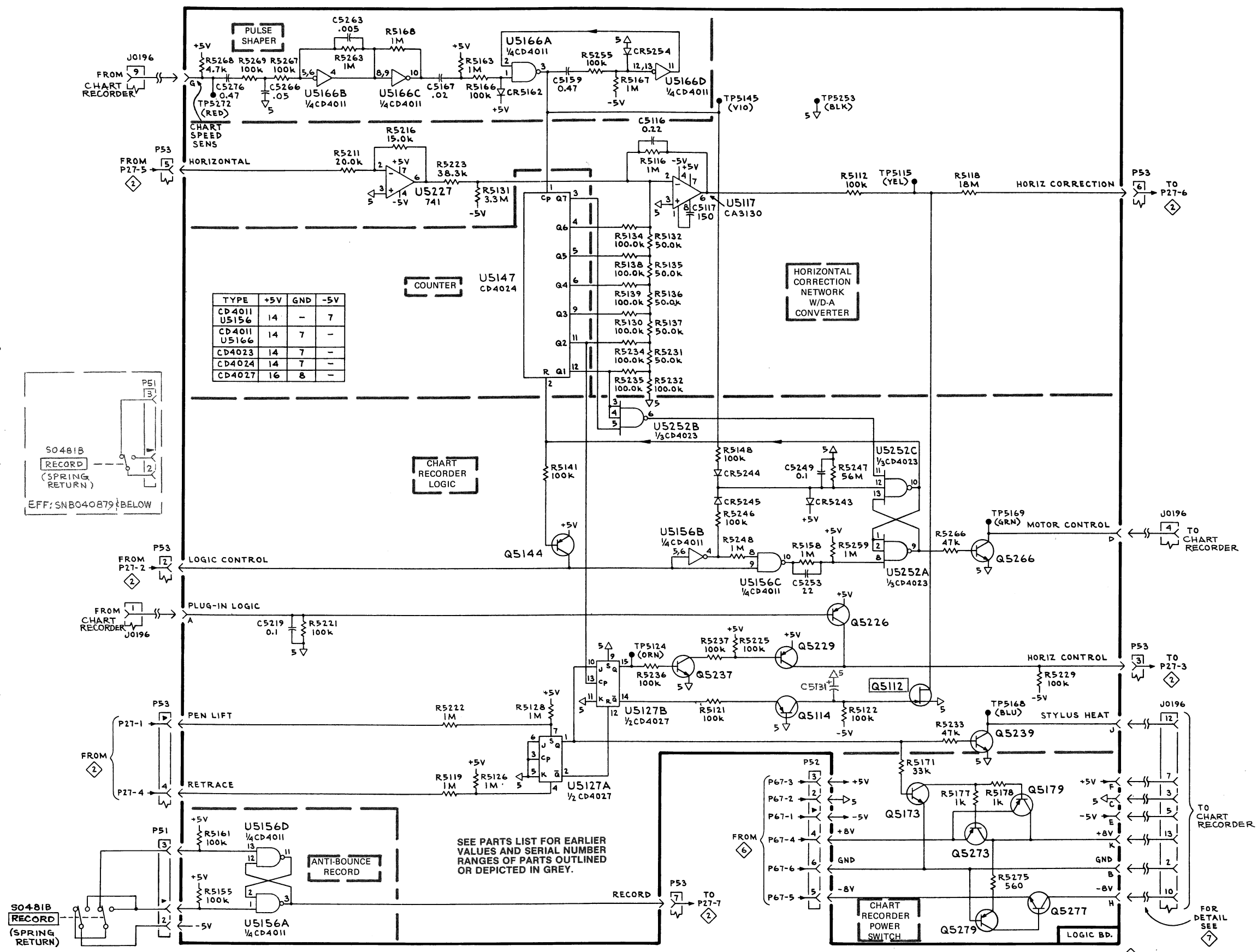

TYPE	+5V	GND	-5V
CD4011	14	-	7
U5156	14	7	-
CD4011	14	7	-
U5166	14	7	-
CD4023	14	7	-
CD4024	14	7	-
CD4027	16	8	-

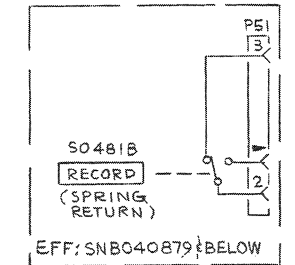

SEE PARTS LIST FOR EARLIER VALUES AND SERIAL NUMBER RANGES OF PARTS OUTLINED OR DEPICTED IN GREY.

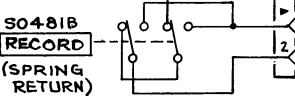

1503

REV. C, NOV 1979

LOGIC 5

LOGIC CIRCUIT 5

POWER SUPPLY COMPONENTS

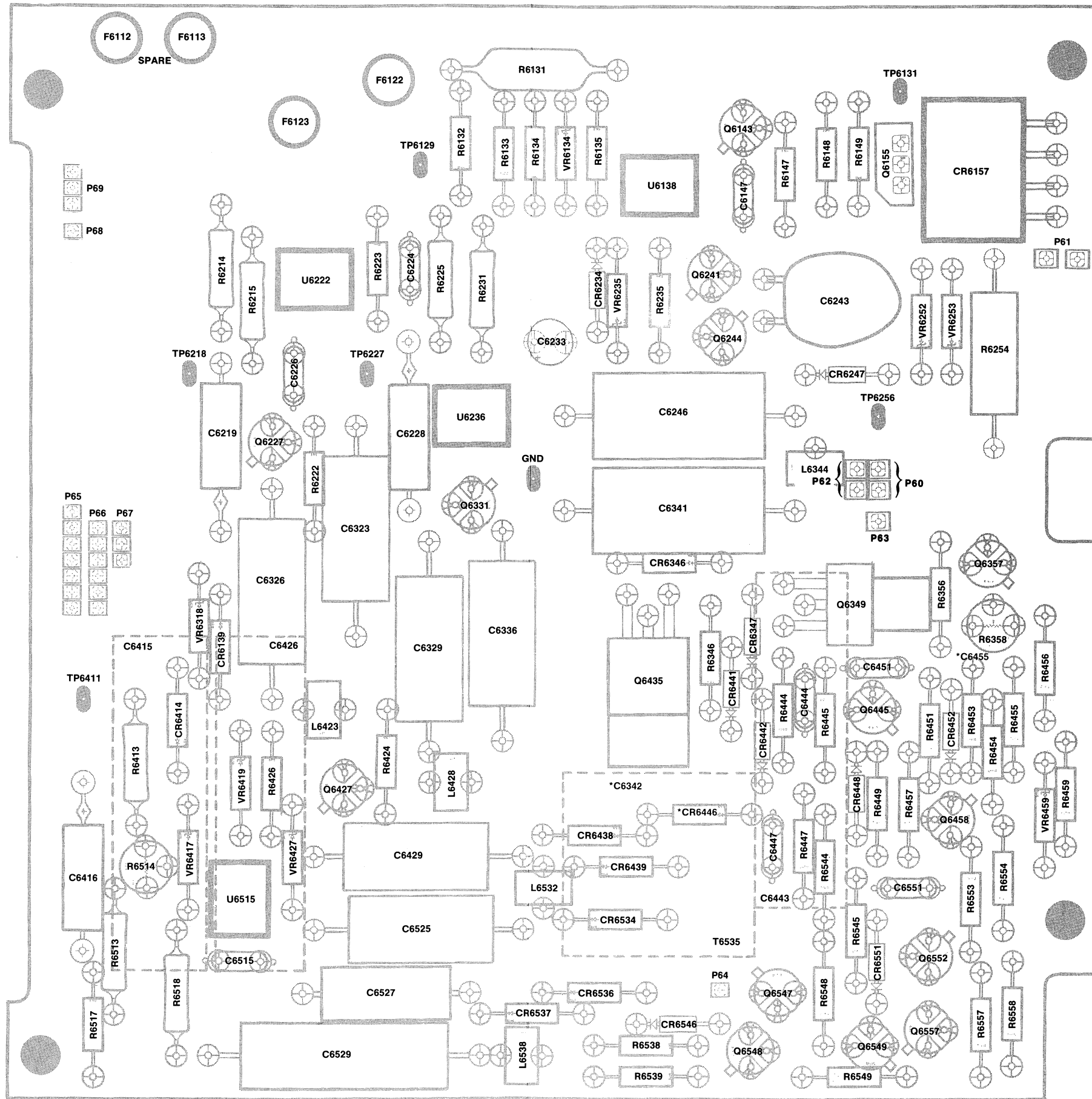

*See Parts List for serial number ranges.

CKT NO	GRID LOC	CKT NO	GRID LOC	CKT NO	GRID LOC
BT0369	F4	L6344	B8	R6518	D8
		L6423	H7	R6538	H1
C0380	D1	L6428	F7	R6539	G1
C0390	C1	L6532	D7	R6544	G5
C6147	D4	L6538	A7	R6545	G4
C6219	H9			R6548	G2
C6224	H8	Q6143	C4	R6549	G1
C6226	H9	Q6155	C5	R6553	G4
C6228	F9	Q6227	H8	R6554	H2
C6233	E3	Q6241	D3	R6557	G1
C6243	D3	Q6244	D3	R6558	H1
C6246	B8	Q6331	F8		
C6323	H7	Q6349	H5	S0165	E5
C6326	H8	Q6357	C7		
C6329	F7	Q6427	D8	T6535	H6
C6336	F7	Q6435	H6		
C6341	B8	Q6445	H5	TP6129	E4
C6342	B7	Q6458	H3	TP6131	E4
C6415	G7	Q6547	H2	TP6218	H9
C6416	D9	Q6548	G1	TP6227	E9
C6426	G7	Q6549	G1	TP6256	B8
C6429	D7	Q6552	H2	TP6411	D9
C6443	G6	Q6557	H1		
C6444	G5			U6138	E3
C6447	H5	R6131	E4	U6222	H8
C6451	G3	R6132	E4	U6236	E8
C6455	C7	R6133	E4	U6515	D8
C6515	D9	R6134	E4		
C6525	D9	R6135	D4	VR6134	D4
C6527	A7	R6147	C4	VR6235	E3
C6529	A7	R6148	C4	VR6252	D4
C6551	H4	R6149	C4	VR6253	D4
		R6214	H9	VR6318	G7
CR6139	F7	R6215	H9	VR6417	D8
CR6157	C3	R6222	H8	VR6419	D8
CR6234	E3	R6223	H8	VR6427	D8
CR6247	D3	R6225	E8	VR6459	H1
CR6346	B7	R6231	E8		
CR6347	G5	R6235	D3		
CR6414	G7	R6254	C4		
CR6438	H7	R6254	C4		
CR6439	F7	R6346	H6		
CR6441	G6	R6356	B7		
CR6442	G6	R6358	C7		
CR6446	H6	R6413	D9		
CR6448	H4	R6424	D8		
CR6452	H3	R6426	D8		
CR6534	D7	R6444	H5		
CR6536	A7	R6445	H5		
CR6537	A7	R6447	G5		
CR6546	G1	R6449	H4		
CR6551	G1	R6451	H3		
		R6453	H3		
F0401	B1	R6454	H2		
F0401	B1	R6455	C7		
F0491	C1	R6456	C8		
F0491	C1	R6457	H4		
F6112	F3	R6459	H1		
F6113	E3	R6513	E9		
F6122	D5	R6514	D9		
F6123	E5	R6517	A7		

A
B
C
D
E
F
G
H

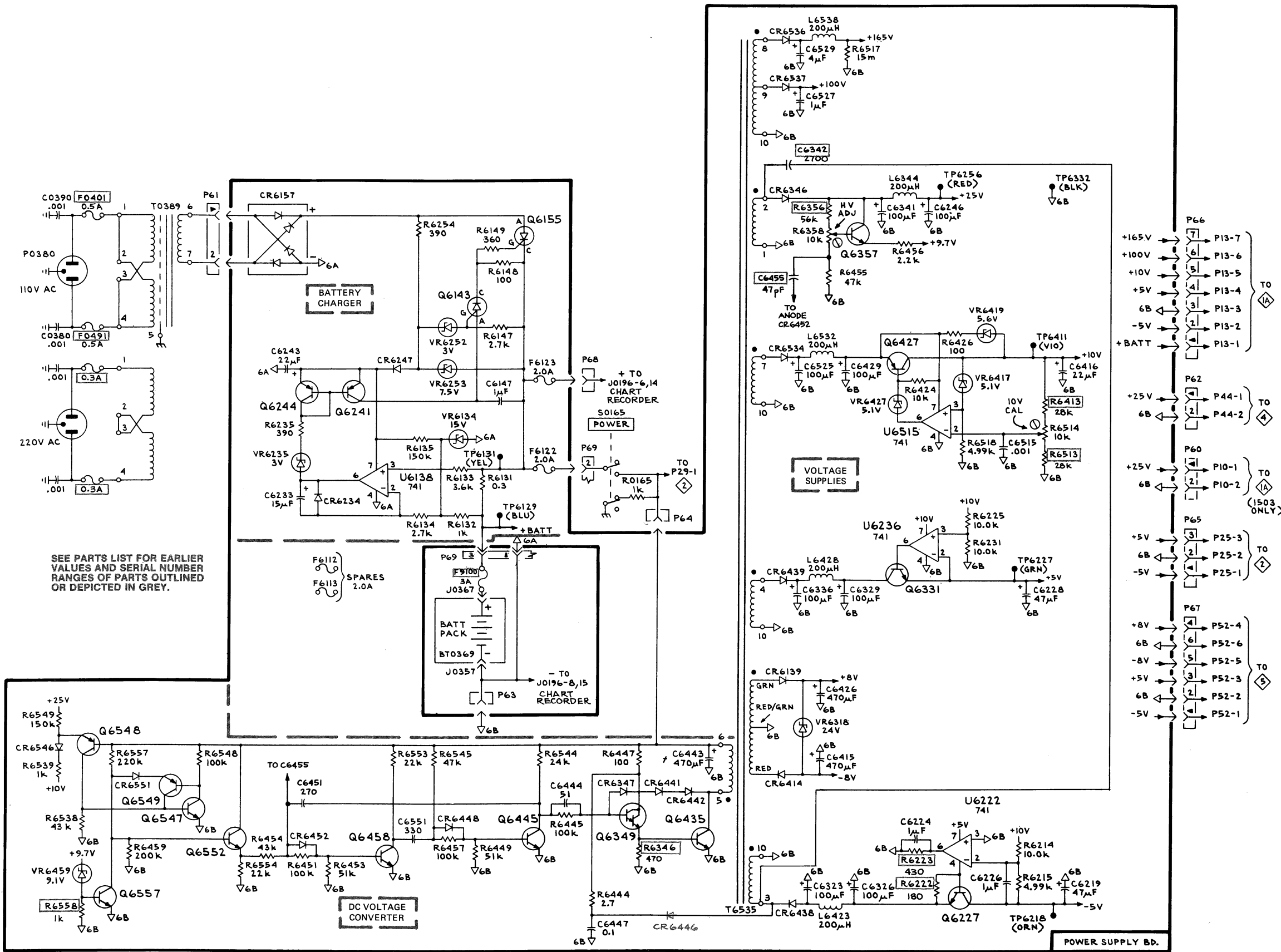

SEE PARTS LIST FOR EARLIER VALUES AND SERIAL NUMBER RANGES OF PARTS OUTLINED OR DEPICTED IN GREY.

F6112
F6113 SPARES 2.0A

POWER SUPPLY CIRCUIT 6

X-Y OUTPUT MODULE
COMPONENTS

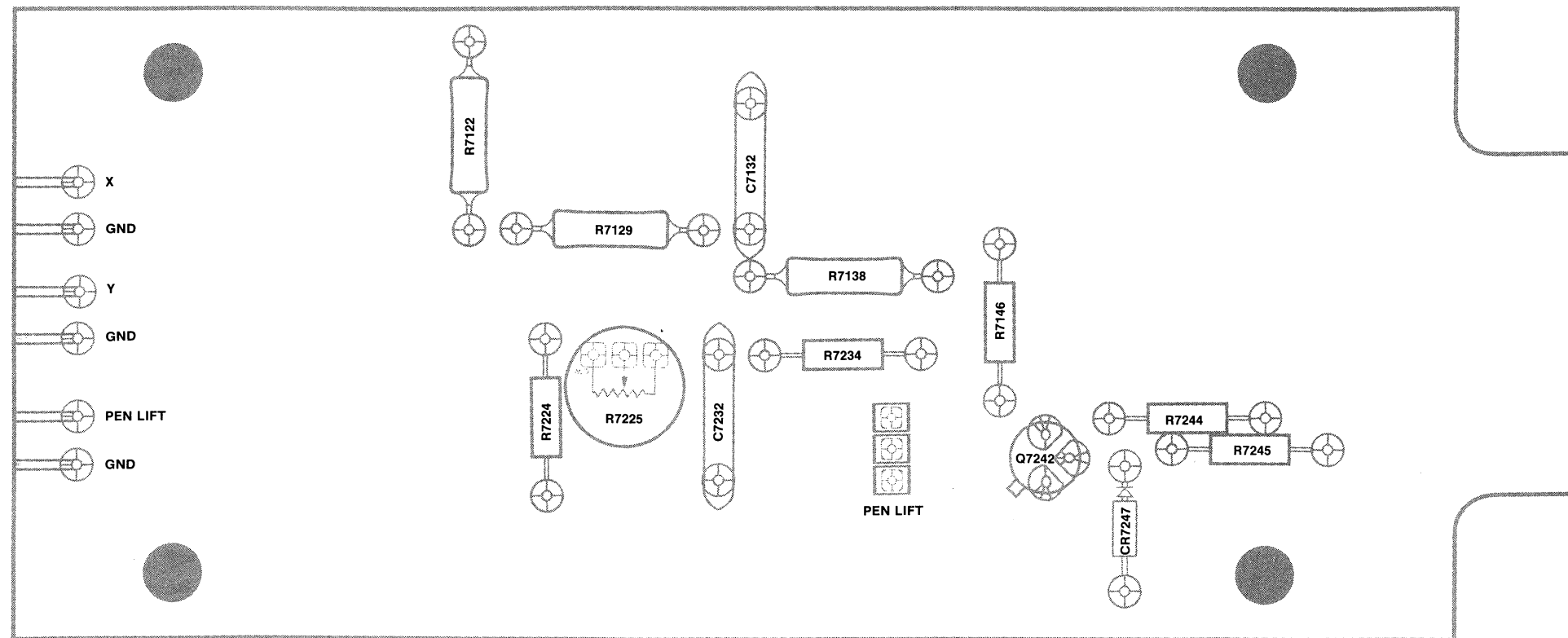

1865-38

X-Y Output Module

CKT NO	GRID LOC
C7132	F6
C7232	E6
CR7247	D6
Q7242	E7
R7122	F7
R7129	F7
R7138	F6
R7146	D6
R7224	E7
R7225	E7
R7234	E6
R7244	E6
R7245	D6

I | 2 | 3 | 4 | 5 | 6 | 7 | 8 | 9 | 10

A
—
B
—
C
—
D
—
E
—
F
—
G
—
H

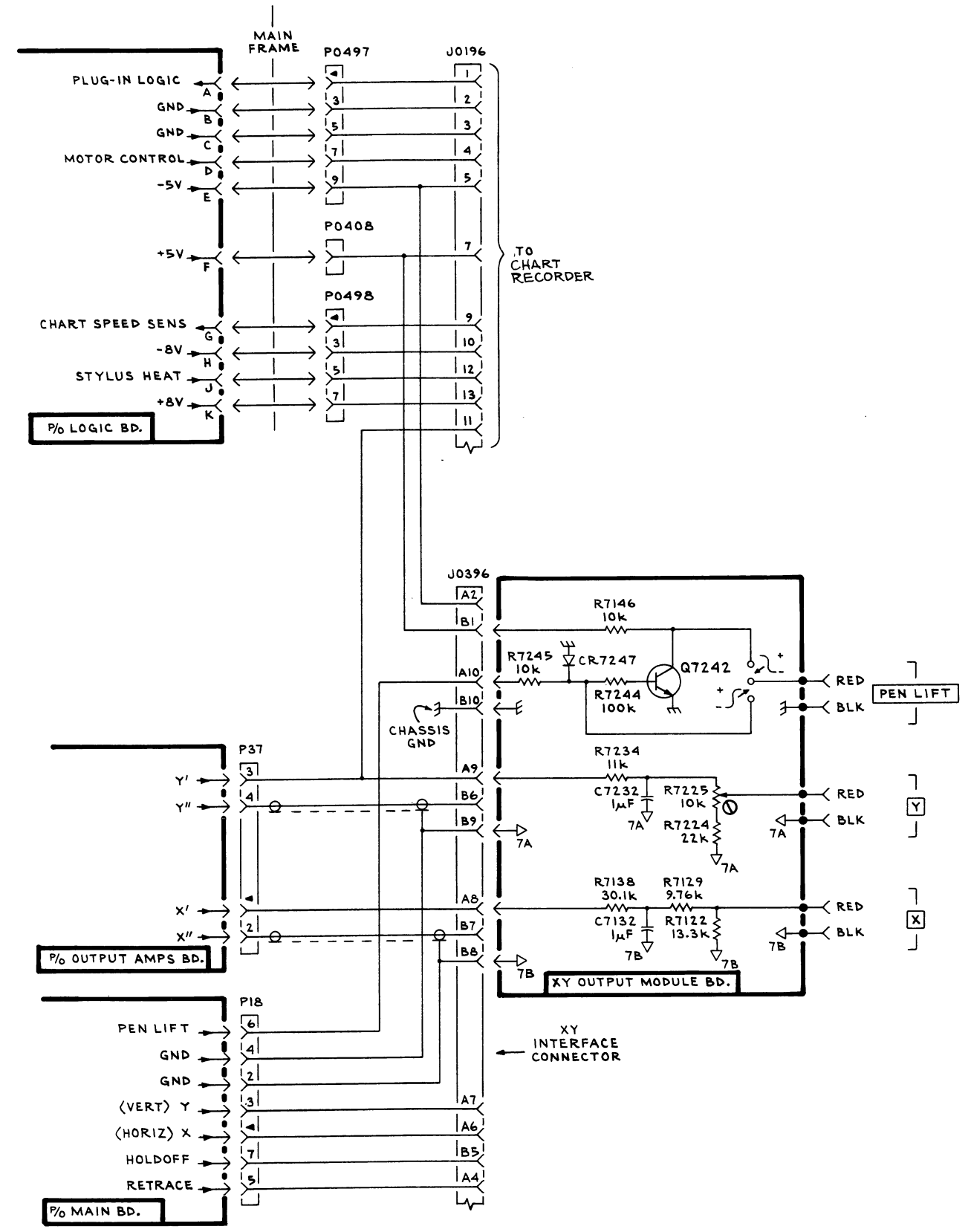

1503

REV. A, FEB. 1978
(1792)1865-39

X-Y OUTPUT MODULE &
CHART RECORDER INTERCONNECT

7

MLL

X-Y OUTPUT MODULE
CIRCUIT

7

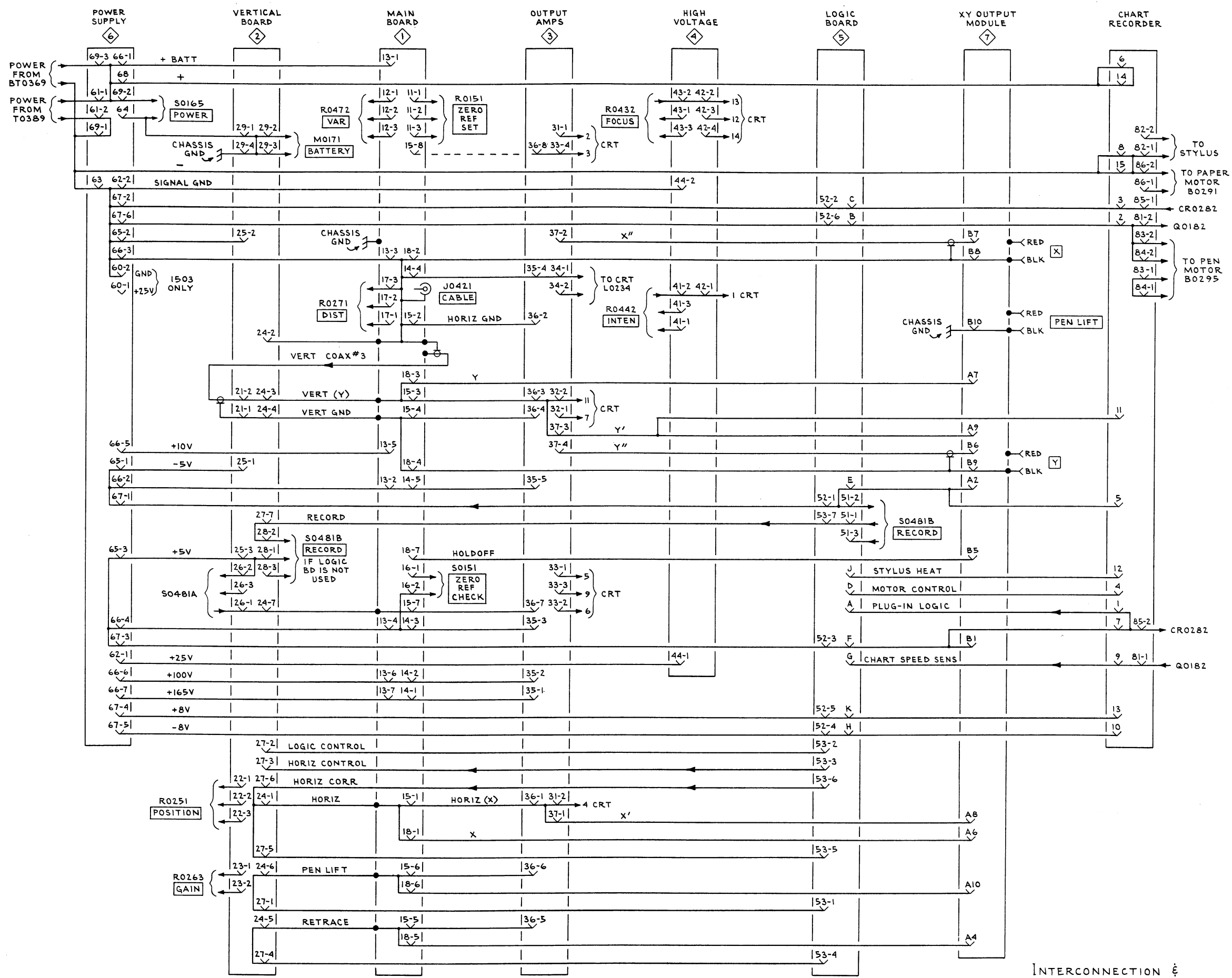

REPLACEABLE MECHANICAL PARTS

PARTS ORDERING INFORMATION

Replacement parts are available from or through your local Tektronix, Inc. Field Office or representative.

Changes to Tektronix instruments are sometimes made to accommodate improved components as they become available, and to give you the benefit of the latest circuit improvements developed in our engineering department. It is therefore important, when ordering parts, to include the following information in your order: Part number, instrument type or number, serial number, and modification number if applicable.

If a part you have ordered has been replaced with a new or improved part, your local Tektronix, Inc. Field Office or representative will contact you concerning any change in part number.

Change information, if any, is located at the rear of this manual.

SPECIAL NOTES AND SYMBOLS

X000 Part first added at this serial number
00X Part removed after this serial number

FIGURE AND INDEX NUMBERS

Items in this section are referenced by figure and index numbers to the illustrations.

INDENTATION SYSTEM

This mechanical parts list is indented to indicate item relationships. Following is an example of the indentation system used in the description column.

```

1 2 3 4 5           Name & Description
Assembly and/or Component
Attaching parts for Assembly and/or Component
    --- * ---
Detail Part of Assembly and/or Component
Attaching parts for Detail Part
    --- * ---
Parts of Detail Part
Attaching parts for Parts of Detail Part
    --- * ---

```

Attaching Parts always appear in the same indentation as the item it mounts, while the detail parts are indented to the right. Indented items are part of, and included with, the next higher indentation. The separation symbol --- * --- indicates the end of attaching parts.

Attaching parts must be purchased separately, unless otherwise specified.

ITEM NAME

In the Parts List, an Item Name is separated from the description by a colon (:). Because of space limitations, an Item Name may sometimes appear as incomplete. For further Item Name identification, the U.S. Federal Cataloging Handbook H6-1 can be utilized where possible.

ABBREVIATIONS

"	INCH	ELCTRN	ELECTRON	IN	INCH	SE	SINGLE END
#	NUMBER SIZE	ELEC	ELECTRICAL	INCAND	INCANDESCENT	SECT	SECTION
ACTR	ACTUATOR	ELECTLT	ELECTROLYTIC	INSUL	INSULATOR	SEMICON	SEMICONDUCTOR
ADPTR	ADAPTER	ELEM	ELEMENT	INTL	INTERNAL	SHLD	SHIELD
ALIGN	ALIGNMENT	EPL	ELECTRICAL PARTS LIST	LPHLDR	LAMPHOLDER	SHLDR	SHOULDERED
AL	ALUMINUM	EQPT	EQUIPMENT	MACH	MACHINE	SKT	SOCKET
ASSEM	ASSEMBLED	EXT	EXTERNAL	MECH	MECHANICAL	SL	SLIDE
ASSY	ASSEMBLY	FIL	FILLISTER HEAD	MTG	MOUNTING	SLFLKG	SELF-LOCKING
ATTEN	ATTENUATOR	FLEX	FLEXIBLE	NIP	NIPPLE	SLVG	SLEEVING
AWG	AMERICAN WIRE GAGE	FLH	FLAT HEAD	NON WIRE	NOT WIRE WOUND	SPR	SPRING
BD	BOARD	FLTR	FILTER	OB	ORDER BY DESCRIPTION	SQ	SQUARE
BRKT	BRACKET	FR	FRAME or FRONT	OD	OUTSIDE DIAMETER	SST	STAINLESS STEEL
BRS	BRASS	FSTNR	FASTENER	OVH	OVAL HEAD	STL	STEEL
BRZ	BRONZE	FT	FOOT	PH BRZ	PHOSPHOR BRONZE	SW	SWITCH
BSHG	BUSHING	FXD	FIXED	PL	PLAIN or PLATE	T	TUBE
CAB	CABINET	GSKT	GASKET	PLSTC	PLASTIC	TERM	TERMINAL
CAP	CAPACITOR	HDL	HANDLE	PN	PART NUMBER	THD	THREAD
CER	CERAMIC	HEX	HEXAGON	PNH	PAN HEAD	THK	THICK
CHAS	CHASSIS	HEX HD	HEXAGONAL HEAD	PWR	POWER	TNSN	TENSION
CKT	CIRCUIT	HEX SOC	HEXAGONAL SOCKET	RCPT	RECEPTACLE	TPG	TAPPING
COMP	COMPOSITION	HLCPS	HELICAL COMPRESSION	RES	RESISTOR	TRH	TRUSS HEAD
CONN	CONNECTOR	HLEXT	HELICAL EXTENSION	RGD	RIGID	V	VOLTAGE
COV	COVER	HV	HIGH VOLTAGE	RLF	RELIEF	VAR	VARIABLE
CPLG	COUPLING	IC	INTEGRATED CIRCUIT	RTNR	RETAINER	W/	WITH
CRT	CATHODE RAY TUBE	ID	INSIDE DIAMETER	SCH	SOCKET HEAD	WSHR	WASHER
DEG	DEGREE	IDNT	IDENTIFICATION	SCOPE	OSCILLOSCOPE	XFMR	TRANSFORMER
DWR	DRAWER	IMPLR	IMPELLER	SCR	SCREW	XSTR	TRANSISTOR

CROSS INDEX—MFR. CODE NUMBER TO MANUFACTURER

Mfr. Code	Manufacturer	Address	City, State, Zip
S3109	C/O PANEL COMPONENTS CORP.	P.O. BOX 6626	SANTA ROSA, CA 95406
000AZ	AIR OIL PROD. CORPORATION	2400 E BURNSIDE	PORTLAND, OR 97214
000BK	STAUFFER SUPPLY	105 SE TAYLOR	PORTLAND, OR 97214
000CY	NORTHWEST FASTENER SALES, INC.	7923 SW CIRRUS DRIVE	BEAVERTON, OR 97005
000EX	O'HARA METAL PRODUCT COMPANY	542 BRANNAN STREET	SAN FRANCISCO, CA 94107
000FW	WESTERN SINTERING CO INC.	2620 STEVENS DRIVE	RICHLAND, WA 99352
0000M	SONY/TEKTRONIX CORPORATION	P O BOX 14, HANEDA AIRPORT	TOKYO 149, JAPAN
00779	AMP, INC.	P O BOX 3608	HARRISBURG, PA 17105
05276	ITT, POMONA ELECTRONICS DIVISION	P O BOX 2767, 1500 E 9TH ST.	POMONA, CA 91766
05574	VIKING INDUSTRIES, INC.	21001 NORDHOFF STREET	CHATSWORTH, CA 91311
06090	RAYCHEM CORPORATION	300 CONSTITUTION DRIVE	MENLO PARK, CA 94025
06540	AMATOM ELECTRONIC HARDWARE, DIV. OF MITE CORP.	446 BLAKE ST.	NEW HAVEN, CT 06515
07322	MINNESOTA RUBBER CO.	3630 WOODDALE AVENUE	MINNEAPOLIS, MN 55416
07707	USM CORP., USM FASTENER DIV.	510 RIVER RD.	SHELTON, CT 06484
08261	SPECTRA-STRIP CORP.	7100 LAMPSON AVE.	GARDEN GROVE, CA 92642
08530	RELIANCE MICA CORP.	342-39TH ST.	BROOKLYN, NY 11232
12327	FREEWAY CORPORATION	9301 ALLEN DRIVE	CLEVELAND, OH 44125
12697	CLAROSTAT MFG. CO., INC.	LOWER WASHINGTON STREET	DOVER, NH 03820
16428	BELDEN CORP.	P. O. BOX 1331	RICHMOND, IN 47374
19209	GENERAL ELECTRIC CO., ELECTRONIC CAPACITOR AND BATTERY PRODUCTS DEPT. BATTERY PRODUCTS SEC.	P. O. BOX 114	GAINESVILLE, FL 32601
22526	BERG ELECTRONICS, INC.	YOUK EXPRESSWAY	NEW CUMBERLAND, PA 17070
22599	ESNA, DIV. OF AMERACE CORPORATION	16150 STAGG STREET	VAN NUYS, CA 91409
22670	G.M. NAMEPLATE, INC.	2040 15TH AVENUE WEST	SEATTLE, WA 98119
24655	GENERAL RADIO CO.	300 BAKER AVE.	CONCORD, MA 01742
24931	SPECIALITY CONNECTOR CO., INC.	2620 ENDRESS PLACE	GREENWOOD, IN 46142
59730	THOMAS AND BETTS COMPANY	36 BUTLER ST.	ELIZABETH, NJ 07207
71126	BRONSON, HOMER D., CO.	250 MAIN ST., P. O. BOX 98	BEACON FALLS, CT 06403
71400	BUSSMAN MFG., DIVISION OF MCGRAW-EDISON CO.	2536 W. UNIVERSITY ST.	ST. LOUIS, MO 63107
71468	ITT CANNON ELECTRIC	666 E. DYER RD.	SANTA ANA, CA 92702
71785	TRW, CINCH CONNECTORS	1501 MORSE AVENUE	ELK GROVE VILLAGE, IL 60007
73743	FISCHER SPECIAL MFG. CO.	446 MORGAN ST.	CINCINNATI, OH 45206
73803	TEXAS INSTRUMENTS, INC., METALLURGICAL MATERIALS DIV.	34 FOREST STREET	ATTLEBORO, MA 02703
74445	HOLO-KROME CO.	31 BROOK ST. WEST	HARTFORD, CT 06110
74970	JOHNSON, E. F., CO.	299 10TH AVE. S. W.	WASECA, MN 56093
75915	LITTELFUSE, INC.	800 E. NORTHWEST HWY	DES PLAINES, IL 60016
76854	OAK INDUSTRIES, INC., SWITCH DIV.	S. MAIN ST.	CRYSTAL LAKE, IL 60014
77250	PHEOLL MANUFACTURING CO., DIVISION OF ALLIED PRODUCTS CORP.	5700 W. ROOSEVELT RD.	CHICAGO, IL 60650
78189	ILLINOIS TOOL WORKS, INC. SHAKEPROOF DIVISION	ST. CHARLES ROAD	ELGIN, IL 60120
78584	STEWART STAMPING CORP.	630 CENTRAL PARK AVE.	YONKERS, NY 10704
79136	WALDES, KOHINOOR, INC.	47-16 AUSTEL PLACE	LONG ISLAND CITY, NY 11101
79807	WROUGHT WASHER MFG. CO.	2100 S. O BAY ST.	MILWAUKEE, WI 53207
80009	TEKTRONIX, INC.	P O BOX 500	BEAVERTON, OR 97077
80126	PACIFIC ELECTRICORD CO.	747 W. REDONDO BEACH,P O BOX 10	GARDENA, CA 90247
83309	ELECTRICAL SPECIALITY CO., SUBSIDIARY OF BELDEN CORP.	213 E. HARRIS AVE. SOUTH	SAN FRANCISCO, CA 94080
83330	SMITH, HERMAN H., INC.	812 SNEDIKER AVE.	BROOKLYN, NY 11207
83385	CENTRAL SCREW CO.	2530 CRESCENT DR.	BROADVIEW, IL 60153
83553	ASSOCIATED SPRING CORP., SEABOARD DIV.	15001 S BROADWAY, P O BOX 231	GARDENA, CA 90248
85471	BOYD, A. B., CO.	2527 GRANT AVENUE	SAN LEANDRO, CA 94579
86445	PENN FIBRE AND SPECIALTY CO., INC.	2032 E. WESTMORELAND ST.	PHILADELPHIA, PA 19134
86928	SEASTROM MFG. COMPANY, INC.	701 SONORA AVENUE	GLENDALE, CA 91201
87308	N. L. INDUSTRIES, INC., SOUTHERN SCREW DIV.	P. O. BOX 1360	STATESVILLE, NC 28677
87664	VAN WATERS AND ROGERS, INC.	P. O. BOX 3200 RINCON ANNEX	SAN FRANCISCO, CA 94119
89663	REESE, J. RAMSEY, INC.	71 MURRAY STREET	NEW YORK, NY 10007
91836	KINGS ELECTRONICS CO., INC.	40 MARBLEDALE ROAD	TUCKAHOE, NY 10707
93410	ESSEX INTERNATIONAL, INC., CONTROLS DIV. LEXINGTON PLANT	P. O. BOX 1007	MANSFIELD, OH 44903
95712	BENDIX CORP., THE ELECTRICAL COMPONENTS DIV., MICROWAVE DEVICES PLANT	HURRICANE ROAD	FRANKLIN, IN 46131
97464	INDUSTRIAL RETAINING RING CO.	57 CORDIER ST.	IRVINGTON, NJ 07111
97539	APM-HEXSEAL CORP.	44 HONECK ST.	ENGLEWOOD, NJ 07631

Fig. & Index No.	Tektronix Part No.	Serial/Model No. Eff Dscont	Qty	1 2 3 4 5	Name & Description	Mfr Code	Mfr Part Number
1-	437-0190-01		1		CAB., TDR ACCESS:	80009	437-0190-01
	105-0684-00	B010100 B082399	2		. LATCH ASSEMBLY:	80009	105-0684-00
	105-0684-01	B082400	2		. LATCH ASSEMBLY:	80009	105-0684-01
					(ATTACHING PARTS)		
-1	211-0510-00		4		. SCREW, MACHINE: 6-32 X 0.375, PNH, STL, CD PL	83385	OBD
	-----				- - - - *		
			1		. LATCH ASSEMBLY INCLUDES:		
-2	367-0212-00	B010100 B082399	1		. . HANDLE, LATCH: 2.108 L, AL	80009	367-0212-00
	367-0212-01	B082400	1		. . HANDLE, LATCH: MOLDING	80009	367-0212-01
					(ATTACHING PARTS)		
-3	214-2350-00		1		. . PIN, STR, HDLS: 0.125 DIA X 2.0 INCH LONG	000BK	OBD
-4	214-2357-00		1		. . PIN, SPRING: 0.375" L X 0.125 OD, STL	22599	52-028-125-0375
					- - - - * - - -		
-5	351-0463-00	B010100 B082399	1		. . GUIDE SHAFT:	80009	351-0463-00
	351-0463-01	B082400	1		. . GUIDE SHAFT: STEEL	80009	351-0463-01
					(ATTACHING PARTS)		
-6	214-1721-00		1		. . PIN, SPRING 0.375 X 0.069	22599	52-012-062-0375
					- - - - * - - -		
-7	214-2352-00		1		. . SPRING, HLCP: 1.0" L X 0.24" OD, MUSIC WIRE	83553	C0240-042-100M
-8	354-0324-00		1		. . RING, RETAINING: E SHAPE, 0.102 ID X 0.270	79136	5133-14-MD
-9	384-1385-00		1		. . EXTENSION SHAFT: 2.274" L X 0.188 OD, STL	80009	384-1385-00
					(ATTACHING PARTS)		
-10	214-2351-00		1		. . PIN, SPRING: 0.375" L X 0.101" OD, STL	22599	52-022-094-0375
					- - - - * - - -		
-11	105-0686-00		1		. . LATCH, COVER:	80009	105-0686-00
					(ATTACHING PARTS)		
-12	214-2349-00		1		. . PIN, STR, HDLS: 0.125 DIA X 1.0 INCH LONG, STL	000BK	OBD
					- - - - * - - -		
-13	361-0762-00		1		. . SPACER, SLEEVE: 0.128 ID X 0.15" L, BRASS	80009	361-0762-00
-14	214-2345-00		1		. . SPR, HLCL, TRSN: 0.665 INCH L X 0.245 OD, SST	80009	214-2345-00
-15	214-2351-00	B010100 B082506X	2		. . PIN, SPRING: 0.375" L X 0.101" OD, STL	22599	52-022-094-0375
-16	426-1271-00	B010100 B082506	1		. . FRAME, LATCH:	80009	426-1271-00
	426-1271-02	B082507	1		. . FRAME, LATCH:	80009	426-1271-02
-17	214-0787-00		1		. . STEM, LATCH: 1.110 X 0.185" WHITE PLSTC	80009	214-0787-00
-18	204-0282-00		1		. . BODY, LATCH: 1.0 X 1.0 X 0.54", BLACK PLSTC	80009	204-0282-00
-19	214-2389-00		2		. . PIN, ACTUATOR: POWER SWITCH	80009	214-2389-00
					(ATTACHING PARTS)		
-20	211-0008-00		2		. SCREW, MACHINE: 4-40 X 0.250, PNH, STL, CD PL	83385	OBD
					- - - - * - - -		
-21	200-1778-00		1		. DOOR, ACCESS: FRONT COVER	80009	200-1778-00
					(ATTACHING PARTS)		
-22	211-0101-00		2		. SCREW, MACHINE: 4-40 X 0.25, 100 DEG, FLH STL	83385	OBD
-23	210-0586-00		2		. NUT PL, ASSEM WA: 4-40 X 0.25, STL CD PL	83385	OBD
					- - - - * - - -		
-24	214-0001-00		1		. HINGE, BUTT: 1.5 X 1.0, BRS	71126	B78
					(ATTACHING PARTS)		
-25	211-0102-00		2		. SCREW, MACHINE: 4-40 X 0.500", FLH, STL	83385	OBD
					- - - - * - - -		
-26	386-3216-00		1		. SUPPORT, HINGE: ACCESS DOOR	80009	386-3216-00
-27	105-0652-00		1		. STRIKE, CATCH: ACCESS DOOR	80009	105-0652-00
					(ATTACHING PARTS)		
-28	211-0102-00		2		. SCREW, MACHINE: 4-40 X 0.500", FLH, STL	83385	OBD
					- - - - * - - -		
-29	200-1759-00		1		. COVER, TDR UNIT: FRONT	80009	200-1759-00
	437-0188-01		1		CAB., TDR UNIT:	80009	437-0188-01
-30	200-1805-00		2		. COV, HDL LATCH:	80009	200-1805-00
					(ATTACHING PARTS)		
-31	213-0739-00		2		. SCREW, MACHINE: 10-32 X 0.375 INCH, HEX HD, STL	83385	OBD
					- - - - * - - -		
-32	210-1231-00		2		. WASHER, FLAT: 0.203 ID X 0.875 OD, STL	86928	5712-82-60-C2
-33	386-3303-01		2		. PLATE, SECURING: HANDLE, STEEL	80009	386-3303-01
-34	107-0035-00		4		. DISC, FRICTION: 0.38 ID X 1.865 OD	80009	107-0035-00
-35	367-0204-01		1		. HANDLE, CARRYING: W/HARDWARE	80009	367-0204-01
-36	334-2468-00		1		. . PLATE, IDENT: MARKED 1502	80009	334-2468-00

Replaceable Mechanical Parts—1503

Fig. & Index No.	Tektronix Part No.	Serial/Model No. Eff Dscont	Qty	1 2 3 4 5	Name & Description	Mfr Code	Mfr Part Number
1-37	437-0188-00		1	.	CAB., TDR UNIT:	80009	437-0188-00
-38	348-0419-00		2	.	FOOT, CABINET: FRONT (ATTACHING PARTS)	80009	348-0419-00
-39	211-0507-00		4	.	SCREW, MACHINE: 6-32 X 0.312 INCH, PNH STL -----*-----	83385	OBD
-40	213-0451-01		4	.	SCREW, EXT, RLV: FOOT, RETAINING (ATTACHING PARTS)	80009	213-0451-01
-41	354-0175-00		4	.	RING, RETAINING: TYPE EXT, U/O 0.188 ID SFT -----*-----	79136	5133-18-MI
	334-2666-00	B010100 B082840	1	.	MARKER, IDENT: MKD 110V	80009	334-2666-00
	334-2666-01	B082841	1	.	MARKER, IDENT: MKD 115VAC	22670	OBD
	334-2667-00	B010100 B082840	1	.	MARKER, IDENT: MARKED 230V	80009	334-2667-00
	-----		-	.	(OPTION 6 ONLY)		
	334-2667-01	B082841	1	.	MARKER, IDENT: MARKED 230VAC	80009	334-2667-01
	-----		-	.	(OPTION 6 ONLY)		
	334-2665-00		1	.	MARKER, IDENT: MARKED CAUTION	80009	334-2665-00
	348-0420-01		2	.	FOOT, CABINET: REAR BLACK POLYURETHANE	80009	348-0420-01
	386-4704-00		2	.	PLATE, REINF: 3.8 X 0.434, STEEL	80009	386-4704-00

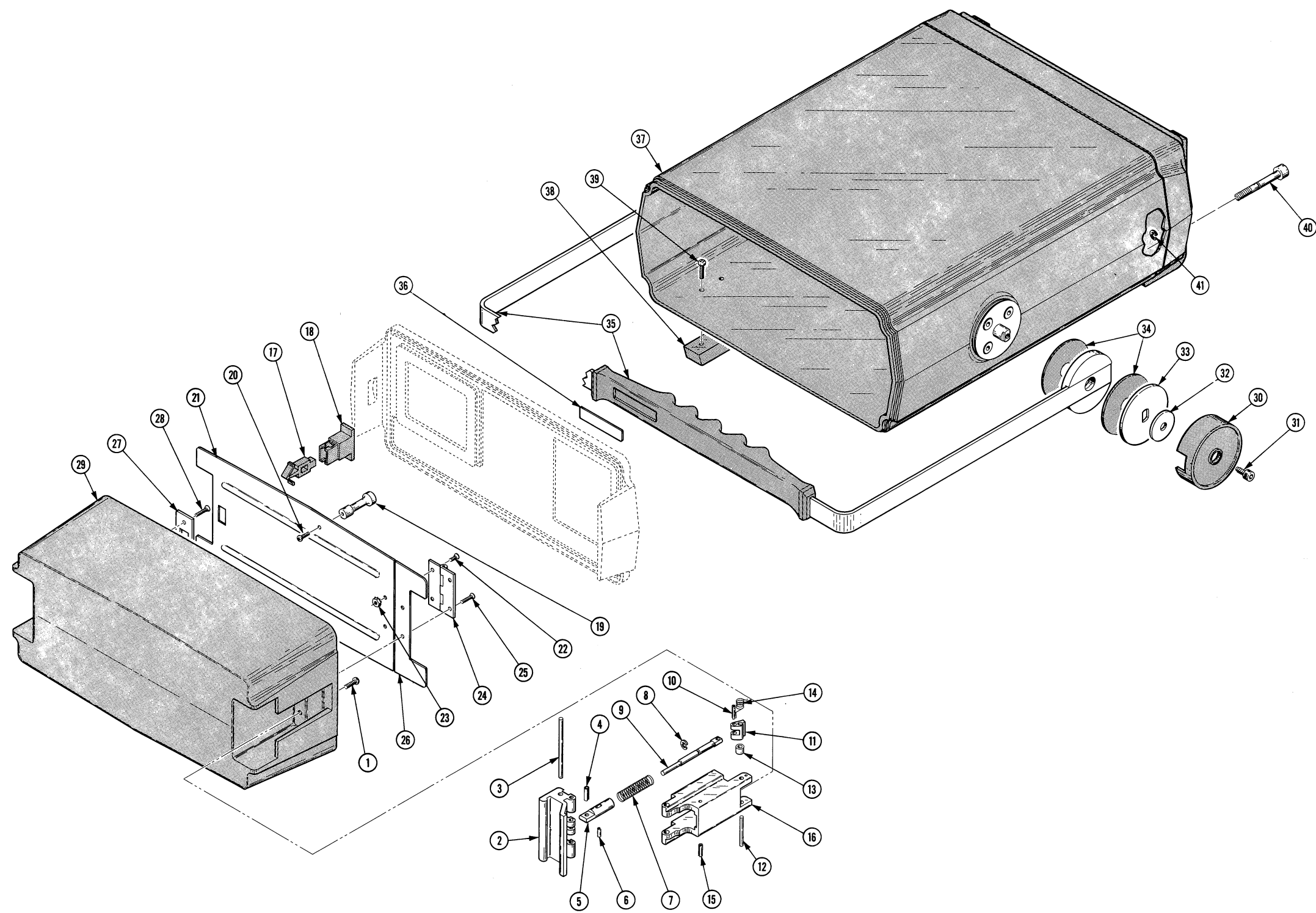

REV A DEC 1980

1503 TIME DOMAIN REFLECTOMETER

FIG. 2 FRONT PANEL, CRT & MAIN/VERTICAL BD ASSEMBLIES

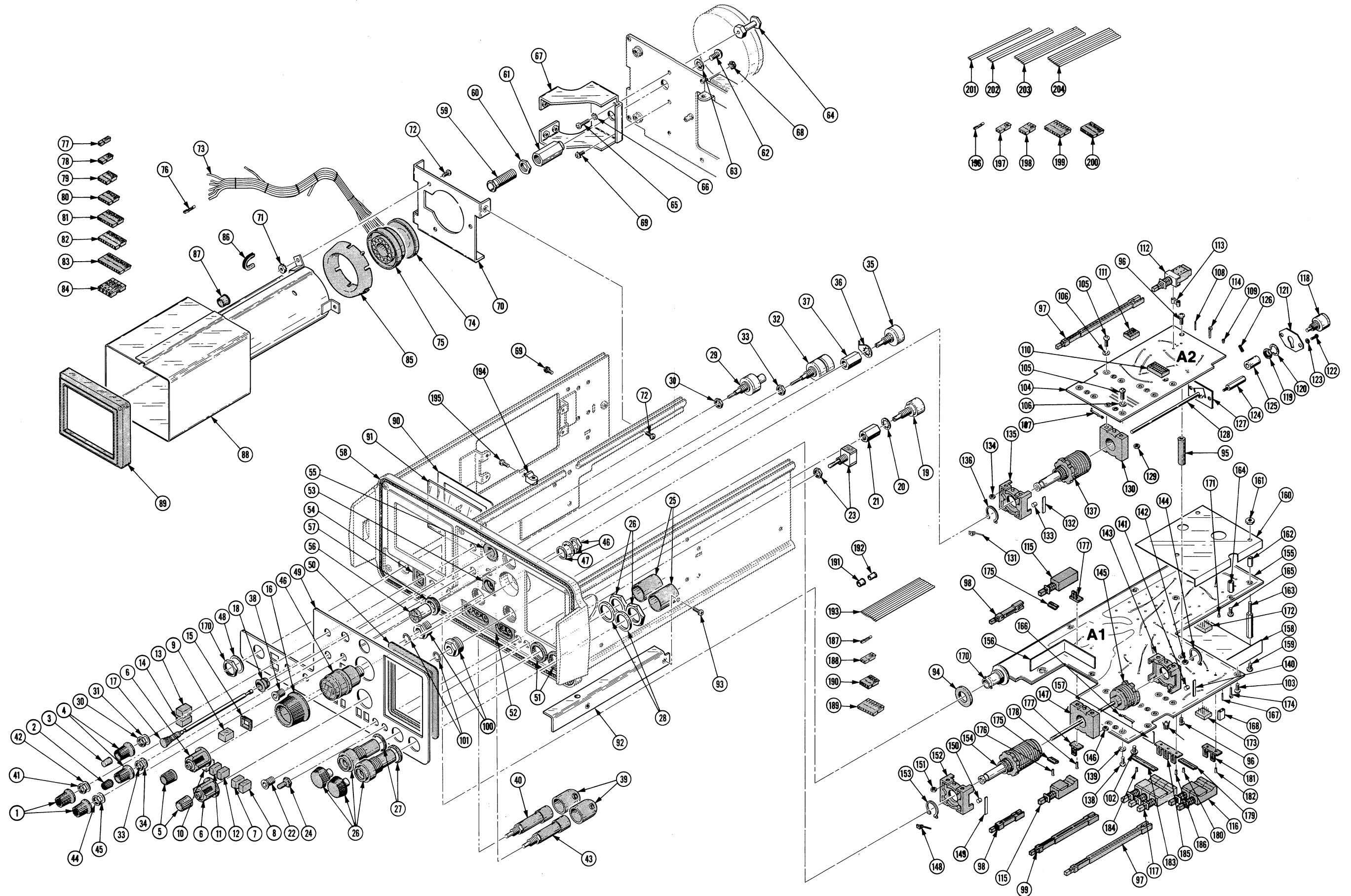

1503 TIME DOMAIN REFLECTOMETER

Fig. & Index No.	Tektronix Part No.	Serial/Model No. Eff Dscont	Qty	1 2 3 4 5	Name & Description	Mfr Code	Mfr Part Number
2-1	366-0494-00		2		KNOB:GRAY WITH SETSCREW	80009	366-0494-00
	213-0153-00		2		. SETSCREW:5-40 X 0.125,STL BK OXD,HEX SKT	000CY	OBD
-2	366-1319-02		1		KNOB:GY,0.79 ID,0.28 OD,0.32 H	80009	366-1319-02
	213-0075-00		1		. SETSCREW:4-40 X 0.094,STL BK OXD,HEX SKT	000BK	OBD
-3	366-1059-00		1		PUSH BUTTON:GRAY	80009	366-1059-00
-4	366-1334-00		2		KNOB:GRAY	80009	366-1344-00
	213-0153-00		2		. SETSCREW:5-40 X 0.125,STL BK OXD,HEX SKT	000CY	OBD
-5	366-1031-00		2		KNOB:RED	80009	366-1031-00
	213-0153-00		2		. SETSCREW:5-40 X 0.125,STL BK OXD,HEX SKT	000CY	OBD
-6	366-1408-00		2		KNOB:GRAY	80009	366-1408-00
	213-0153-00		4		. SETSCREW:5-40 X 0.125,STL BK OXD,HEX SKT	000CY	OBD
-7	366-1620-11		1		PUSH BUTTON:GRAY-SOLID POL	80009	366-1620-11
-8	366-1620-09		1		PUSH BUTTON:GRAY--FOAM POL	80009	366-1620-09
-9	366-1620-02		1		PUSH BUTTON:GRAY--NOISE FILTER	80009	366-1620-02
-10	366-1620-03		1		PUSH BUTTON:GRAY--10	80009	366-1620-03
-11	366-1620-04		1		PUSH BUTTON:GRAY--100	80009	366-1620-04
-12	366-1620-05		1		PUSH BUTTON:GRAY--1000	80009	366-1620-05
-13	366-1620-06		1		PUSH BUTTON:GRAY--50 OHM	80009	366-1620-06
-14	366-1620-07		1		PUSH BUTTON:GRAY--75 OHM	80009	366-1620-07
	366-1620-00		3		PUSH BUTTON:SIL GY,0.43 X 0.326 X 0.253	80009	366-1620-00
	-----		-		(OPTION 2 ONLY)		
-15	426-0681-00		8		FR,PUSH BUTTON:GRAY PLASTIC	80009	426-0681-00
-16	366-1269-00	B010100 B039999	1		KNOB:GY,1.041 OD X0.7 H,ABS	80009	366-1269-00
	366-1269-05	B040000	1		SHELL,KNOB:GY,1.041 OD X0.7 H,PC W/LE	80009	366-1269-05
-17	384-1159-01		1		EXTENSION SHAFT:4.5 INCH LONGW/KNOB	80009	384-1159-01
-18	358-0216-00		1		BUSHING,PLASTIC:0.257 ID X 0.412 INCH OD	80009	358-0216-00
-19	-----		1		RESISTOR,VAR:(SEE R0472 EPL)		
-20	210-0046-00		1		WASHER,LOCK:0.261 ID,INTL,0.018 THK,BRS	78189	1214-05-00-0541C
-21	129-0290-00		1		POST,ELEC-MECH:0.635 INCH LONG,HEX	80009	129-0290-00
					(ATTACHING PARTS)		
-22	358-0342-00		1		BSHG,MACH.THD:0.25 X 32 X 0.352 INCH LONG	80009	358-0342-00
					-----*		
-23	-----		1		SWITCH,TOGGLE:(SEE S0481A,S0481B REPL)		
					(ATTACHING PARTS)		
-24	200-1744-00		1		CAP.,TOGGLE SW:SEAL,25-40 THD	97539	N5040
					-----*		
-25	162-0593-00	B010100 B051371	FT		INS SLV,ELEC:0.5 INCH DIA,BLUE HEAT SHRINK	06090	1004040
	162-0031-00	B051372	FT		INSUL SLVG,ELEC:HEAT SHRINK,0.54 ID	93410	FL25090
-26	352-0362-00		2		FUSEHOLDER: W/MOUNTING HARDWARE	75915	345001
	220-0859-00	XB040839	2		NUT,PLAIN,HEX:5-28 THD X 0.688 HEX,STL	80009	220-0859-00
-27	210-1246-00		2		WASHER,FLAT:0.5 ID X 0.688 OD,STL	80009	210-1246-00
-28	210-1242-00		2		WASHER,FLAT:0.51 ID X 0.688 OD,AL	86928	5712-113-90
-29	-----		1		RES.,VAR,WW:(SEE R0151 REPL)		
					(ATTACHING PARTS)		
-30	210-0583-00	B010100 B093425X	2		NUT,PLAIN,HEX:0.25-32 X 0.312 INCH,BRS	73743	2X20317-402
-31	210-0940-00	B010100 B079999	1		WASHER,FLAT:0.25 ID X 0.375 INCH OD,STL	79807	OBD
	220-0484-00	B080000 B093425X	1		NUT,PLAIN,HEX.:0.25-32 X 0.375 INCH AL	80009	220-0484-00
					-----*		
	-----		-		RESISTOR ASSY INCLUDES:		
	-----		1		. RESISTOR,VAR:(SEE R0151 REPL)		
	210-0583-00		2		. NUT,PLAIN,HEX:0.25-32 X 0.312 INCH,BRS	73743	2X20317-402
	220-0484-00		1		. NUT,PLAIN,HEX.:0.25-32 X 0.375 INCH AL	80009	220-0484-00
	-----		1		. SWITCH,PUSH:(SEE S0151 REPL)		
-32	-----		1		RESISTOR,VAR:(SEE R0251A,R0251B REPL)		
					(ATTACHING PARTS)		
-33	210-0583-00		2		NUT,PLAIN,HEX:0.25-32 X 0.312 INCH,BRS	73743	2X20317-402
-34	210-0940-00		1		WASHER,FLAT:0.25 ID X 0.375 INCH OD,STL	79807	OBD
					-----*		
-35	-----		1		RESISTOR,VAR:(SEE R0263 REPL)		
-36	210-0223-00		1		TERMINAL,LUG:0.25 INCH DIA,SE	86928	A313-136
-37	129-0290-00		1		POST,ELEC-MECH:0.635 INCH LONG,HEX	80009	129-0290-00
					(ATTACHING PARTS)		
-38	358-0342-00		1		BSHG,MACH.THD:0.25 X 32 X 0.352 INCH LONG	80009	358-0342-00
					-----*		

Replaceable Mechanical Parts—1503

Fig. & Index No.	Tektronix Part No.	Serial/Model No. Eff Dscont	Qty	1 2 3 4 5	Name & Description	Mfr Code	Mfr Part Number
2-39	200-1341-00		2		COVER, INS, HV: MOLDE BLACK	80009	200-1341-00
-40	-----		1		RESISTOR, VAR: (SEE R0432 REPL) (ATTACHING PARTS)		
-41	210-0583-00		1		NUT, PLAIN, HEX: 0.25-32 X 0.312 INCH, BRS	73743	2X20317-402
-42	210-0940-00		1		WASHER, FLAT: 0.25 ID X 0.375 INCH OD, STL	79807	OBD
-43	-----		1		RESISTOR, VAR: (SEE R0442 REPL) (ATTACHING PARTS)		
-44	210-0583-00		1		NUT, PLAIN, HEX: 0.25-32 X 0.312 INCH, BRS	73743	2X20317-402
-45	210-0940-00		1		WASHER, FLAT: 0.25 ID X 0.375 INCH OD, STL	79807	OBD
-46	354-0563-00	XB040000	1		PACKING, PREFMD: 0.65 ID X 0.74 OD	000AZ	5-64 N506-65
-47	210-1085-00		1		RESISTOR, VAR: (SEE R0271 REPL), W/HARDWARE		
-48	210-0845-00		1		WASHER, FLAT: 0.375 ID X 0.75 INCH OD, STL	12327	OBD
-49	333-2003-02		1		WASHER, FLAT: 0.500 ID X 0.625 INCH OD, STL	89663	634-R
	333-2123-00	B010100 B040879	1		PANEL, FRONT:	80009	333-2003-02
	-----		1		PANEL, FRONT: W/PLUG-IN SEAL (OPTION 5 ONLY)	80009	333-2123-00
	333-2123-02	B040880	1		PANEL, FRONT:	80009	333-2123-02
	-----		1		(OPTION 5 ONLY)		
	333-2467-01	XB061432	1		PANEL, FRONT:	80009	333-2467-01
	-----		1		(OPTION 1 AND 5 ONLY)		
-50	348-0421-00	B010100 B040879	1		. SEAL, INDICATOR: BATTERY LEVEL	80009	348-0421-00
	-----	B040880	1		. SEAL, INDICATOR: BATTERY LEVEL		
	-----		1		(REPLACEABLE WITH FRONT PANEL ASSY)		
-51	210-1245-00		2		WASHER, FLAT: 0.375 ID X 0.562 OD, STL	85471	OBD
-52	348-0409-04		1		SEAL, PB: 5 BUTTON	80009	348-0409-04
-53	348-0409-01		1		SEAL, PB: 1 BUTTON	80009	348-0409-01
-54	348-0409-02		1		SEAL, PB: 2 BUTTON	80009	348-0409-02
-55	348-0422-00		1		SEAL, SWITCH: POWER	80009	348-0422-00
-56	-----		1		METER, ELEC FREQ: (SEE M0171 REPL)		
-57	352-0243-00		1		HOLDER, INDICATR: BATTERY LEVEL, PLASTIC	80009	352-0243-00
-58	348-0477-00		2		SEAL, RBR STRIP: 0.94 X 28.0 INCH LONG	85471	OBD
-59	213-0738-00		1		SCREW, ADJUSTING: 1.188 INCH LONG	80009	213-0738-00
-60	220-0415-00		1		NUT, PLAIN, HEX: 0.312-32 X 0.013" THK, BRS	73743	2X-28046-402
-61	129-0602-00		1		POST, ELEC-MECH: 1.14" L, 0.438 HEX BRASS (ATTACHING PARTS)	80009	129-0602-00
-62	212-0507-00		1		SCREW, MACHINE: 10-32 X 0.375 INCH, PNH STL	83385	OBD
-63	210-0009-00		1		WASHER, LOCK: EXT, 0.193 ID X 0.40" OD, STL	78189	1110-00
-64	129-0562-00		1		POST, RETAINER: 0.892 INCH LONG X 0.375 HEX (ATTACHING PARTS)	80009	129-0562-00
-65	211-0198-00		1		SCREW, MACHINE: 4-40 X 0.438 PNH, STL, POZ	77250	OBD
-66	210-0003-00		1		WASHER, LOCK: EXT, 0.123 ID X 0.245" OD, STL	78189	1104-00-00-0541C
-67	386-3520-00		1		SUPPORT, CRT: REAR (ATTACHING PARTS)	80009	386-3520-00
-68	210-0586-00		1		NUT, PL, ASSEM WA: 4-40 X 0.25, STL CD PL	83385	OBD
-69	211-0033-00		6		SCR, ASSEM WSHR: 4-40 X 0.312 PNH, STL, CD PL	83385	OBD
-70	386-3153-00		1		SUPPORT, CRT SH: REAR (ATTACHING PARTS)	80009	386-3153-00
-71	210-0586-00		3		NUT, PL, ASSEM WA: 4-40 X 0.25, STL CD PL	83385	OBD
-72	211-0008-00		6		SCREW, MACHINE: 4-40 X 0.250, PNH, STL, CD PL	83385	OBD
-73	136-0644-00		1		SOCKET ASSY: CRT	80009	136-0644-00
-74	386-1316-00		1		. SUPPORT, CRT: REAR	80009	386-1316-00
-75	136-0266-01		1		. SKT, PL-IN ELEKTRN TUBE, 12 CONT, W/LEADS	0000M	OBD
-76	131-0707-00		55		. CONNECTOR, TERM: 22-26 AWG, BRS & CU BE GOLD	22526	47439
	131-0708-00		2		. CONTACT, ELEC: 0.48"L, 28-32 AWG WIRE	22526	47437
	131-0621-00		4		. CONNECTOR, TERM: 22-26 AWG, BRS & CU BE GOLD	22526	46231
-77	352-0171-03		1		. CONN BODY, PL, EL: 1 WIRE ORANGE	80009	352-0171-03
	352-0171-08		1		. CONN BODY, PL, EL: 1 WIRE GRAY	80009	352-0171-08
	352-0171-09		1		. CONN BODY, PL, EL: 1 WIRE WHITE	80009	352-0171-09

Fig. & Index No.	Tektronix Part No.	Serial/Model No. Eff Dscont	Qty	1 2 3 4 5	Name & Description	Mfr Code	Mfr Part Number
2-78	352-0169-01		1		. HLDR TERM CONN:2 WIRE,BROWN	80009	352-0169-01
	352-0169-02		1		. CONN BODY,PL,EL:2 WIRE RED	80009	352-0169-00
-79	352-0162-03		1		. CONN BODY,PL,EL:4 WIRE ORANGE	80009	352-0162-03
	352-0162-07		1		. CONN BODY,PL,EL:4 WIRE VIOLET	80009	352-0162-07
-80	352-0163-04		1		. CONN BODY,PL,EL:5 WIRE YELLOW	80009	352-0163-04
	352-0163-05		1		. CONN BODY,PL,EL:5 WIRE GREEN	80009	352-0163-05
-81	352-0165-08		1		. CONN BODY,PL,EL:7 WIRE GRAY	80009	352-0165-08
	352-0165-09		1		. CONN BODY,PL,EL:7 WIRE WHITE	80009	352-0165-09
-82	352-0166-05		1		. CONN BODY,PL,EL:8 WIRE GREEN	80009	352-0166-05
	352-0166-06		1		. CONN BODY,PL,EL:8 WIRE BLUE	80009	352-0166-06
-83	352-0168-09		1		. CONN BODY,PL,EL:10 WIRE WHITE	80009	352-0168-09
-84	352-0200-02		1		. CONN BODY,PL EL:4 WIRE RED	80009	352-0200-02
-85	386-3113-00		1		SUPPORT,CRT:REAR	80009	386-3113-00
-86	348-0239-00		1		GROMMET,PLASTIC:DK GRAY,U-SHAPE,0.27 ID	80009	348-0239-00
-87	348-0067-00		1		GROMMET,PLASTIC:0.312 INCH DIA	80009	348-0067-00
-88	337-2085-00		1		SHIELD,CRT:	80009	337-2085-00
-89	386-3112-00		1		SUPPORT,CRT:FRONT	80009	386-3112-00
-90	343-0610-00		1		RETAINER,SHLD:IMPLOSION	80009	343-0610-00
-91	337-2206-00		1		SHLD,IMPLOSION:CRT,CLEAR	80009	337-2206-00
-92	407-1589-00		1		BRACKET,ANGLE:PLUG IN GUIDE,ALUMINUM (ATTACHING PARTS)	80009	407-1589-00
-93	211-0008-00		2		SCREW,MACHINE:4-40 X 0.250,PNH,STL,CD PL - - - * - - - -	83385	OBD
-94	210-1251-00		1		WASHER,FLAT:0.5 ID X 0.688 OD,SPONGE	80009	210-1251-00
-95	129-0554-00		1		SPACER,POST:0.975" L W/4-40 THD,PLSTC (ATTACHING PARTS)	80009	129-0554-00
-96	211-0008-00		2		SCREW,MACHINE:4-40 X 0.250,PNH,STL,CD PL - - - * - - - -	83385	OBD
-97	384-1101-00		3		EXTENSION SHAFT:4.14 INCH LONG	80009	384-1101-00
-98	384-1099-00		2		EXTENSION SHAFT:PUSH BUTTON,1.54 INCH LONG	80009	384-1099-00
-99	384-1368-00		3		EXTENSION SHAFT:3.31 INCH L,MOLDED PLASTIC	80009	384-1368-00
	334-2450-00		1		MARKER,IDENT:MKD DANGER 165	80009	334-2450-00
	672-0498-00		1		CKT BOARD ASSY:MAIN-VERT W/CAM SWITCH	80009	672-0498-00
	672-0575-00		1		CKT BOARD ASSY:MAIN-VERT W/CAM SWITCH (OPTION 5 ONLY)	80009	672-0575-00
	-----		-		(ATTACHING PARTS)		
-100	377-0451-00		2		INSERT SFT SEAL:0.625 OD X 0.407,0.562-18	80009	377-0451-00
-101	354-0555-00		2		PACKING,PREFMD:0.25 ID X 0.375 INCH OD	07322	8010-559AN
-102	211-0116-00		2		SCR,ASSEM WSHR:4-40 X 0.312 INCH,PNH BRS	83385	OBD
-103	213-0088-00		1		SCR,TPG,THD CTG:4-24 X 0.25 INCH,PNH STL - - - * - - - -	83385	OBD
	-----		-		MAIN AND VERTICAL BOARD ASSEMBLY INCLUDES:		
-104	-----		1		. CKT BOARD ASSY:VERTICAL(SEE A2 REPL) (ATTACHING PARTS)		
-105	211-0148-01		10		. SCREW,MACHINE:4-40 X 0.312 INCH,PNH,SST	83385	OBD
-106	210-1002-00		10		. WASHER,FLAT:0.125 ID X 0.25 INCH OD,BRS - - - * - - - -	12327	OBD
	-----		-		. CKT BOARD ASSEMBLY INCLUDES:		
-107	131-0604-00		7		. . CONTACT,ELEC:CKT BD SW,SPR,CU BE	80009	131-0604-00
-108	131-0608-00		34		. . TERMINAL,PIN:0.365 L X 0.025 PH BRZ GOLD	22526	47357
-109	136-0252-04	B010100 B082958X	36		. . SOCKET,PIN TERM:U/W 0.016-0.018 DIA PINS	22526	75060-007
-110	136-0269-02	B010100 B082958X	1		. . SKT,PL-IN ELEK:MICROCIRCUIT,14 DIP,LOW CLE	73803	CS9002-14
-111	136-0514-00	B010100 B082958X	3		. . SKT,PL-IN ELEC:MICROCIRCUIT,8 DIP	73803	CS9002-8
-112	-----		1		. . SWITCH,PUSH:(SEE S2254 REPL)		
-113	361-0384-00		2		. . SPACER,PB SW:0.133 INCH LONG	80009	361-0384-00
-114	214-0579-00		6		. . TERM,TEST POINT:BRS CD PL	80009	214-0579-00
	162-0504-00		FT		. . INSUL SLVG,ELEC:0.034 ID,BLACK,0.016 FT L	93410	F5B2011
	162-0510-00		FT		. . INSUL SLVG,ELEC:0.034 ID,RED,0.016 FT L	93410	F5B2021
	162-0516-00		FT		. . INSUL SLVG,ELEC:0.034 ID,YELLOW,0.016 FT L	93410	F5B2041
	162-0520-00		FT		. . INSUL SLVG,ELEC:0.034 ID,GREEN,0.016 FT L	93410	F5B2031
	162-0524-00		FT		. . INSUL SLVG,ELEC:0.034 ID,BLUE,0.016 FT L	93410	F5B2051
	162-0578-00		FT		. . INSUL SLVG,ELEC:0.034 ID,VIOLET,0.016 FT L	93410	F5B1861

Replaceable Mechanical Parts—1503

Fig. & Index No.	Tektronix Part No.	Serial/Model No. Eff	Dscont	Qty	1	2	3	4	5	Name & Description	Mfr Code	Mfr Part Number
2-115	-----	-----		1	ACTR ASSY,PB:(SEE S1624 REPL)		
-116	-----	-----		1	ACTR ASSY,PB:(SEE S1625 REPL)		
-117	-----	-----		1	ACTR ASSY,PB:(SEE S1343 REPL)		
				1	ACTR ASSY,CAM S:(SEE S1215 REPL) (ATTACHING PARTS)		
	211-0148-01			4	SCREW,MACHINE:4-40 X 0.312 INCH,PNH,SST	83385	OBD
	210-1002-00			4	WASHER,FLAT:0.125 ID X 0.25 INCH OD,BRS	12327	OBD
										-----*-----		
				-	ACTUATOR ASSEMBLY INCLUDES:		
-118	311-1005-00			1	RES.,VAR,NONWIR:15K OHM,10%,0.50W	12697	382-CM40952
-119	210-0583-00			1	NUT,PLAIN,HEX:0.25-32 X 0.312 INCH,BRS	73743	2X20317-402
-120	210-0046-00			1	WASHER,LOCK:0.261 ID,INTL,0.018 THK,BRS	78189	1214-05-00-0541C
										-----*-----		
-121	386-1792-00			1	PL,VAR RES MTC:STEEL CD PL (ATTACHING PARTS)	80009	386-1792-00
-122	211-0001-00			2	SCREW,MACHINE:2-56 X 0.25 INCH,PNH STL	87308	OBD
-123	210-0001-00			2	WASHER,LOCK:INTL,0.092 ID X 0.18"OD,STL	78189	1202-00-00-0541C
										-----*-----		
-124	129-0586-00			2	SPACER,POST:0.875 L,W/2-56 THD,BRS	80009	129-0586-00
-125	376-0029-01			1	CPLG,SHAFT,RGD:0.125 SHAFT	80009	376-0029-01
-126	213-0075-00			2	SETScrew:4-40 X 0.094,STL BK OXD,HEX SKT	000BK	OBD
	354-0561-00	XB020311		1	PACKING,PREFMD:0.176 ID X 0.312 OD	000AZ	2-008-N674-7
-127	105-0683-00			1	STOP,ELEC SW:	80009	105-0683-00
-128	384-0313-00			1	EXTENSION SHAFT:0.125 DIA X 3.375 INCH LONG	80009	384-0313-00
-129	210-0406-00			4	NUT,PLAIN,HEX.:4-40 X 0.188 INCH,BRS	73743	12161-50
-130	401-0113-01			1	BEARING,CAM SW:REAR	80009	401-0113-01
-131	131-0963-00			2	CONTACT,ELEC:GROUNDING	000EX	OBD
-132	214-1139-02			2	SPRING,FLAT:GREEN COLORED	80009	214-1139-02
-133	214-1127-00			2	ROLLER,DETENT:0.125 DIA X 0.125,SST	80009	214-1127-00
-134	210-0406-00			4	NUT,PLAIN,HEX.:4-40 X 0.188 INCH,BRS	73743	12161-50
-135	401-0081-02			1	BEARING,CAM SW:FRONT (ATTACHING PARTS)	80009	401-0081-02
-136	354-0391-00			1	RING,RETAINING:0.395"FREE ID X 0.025" STL (ATTACHING PARTS)	97464	3100-43-CD
										-----*-----		
-137	105-0687-00			1	ACTUATOR,SWITCH:CAM SWITCH	80009	105-0687-00
	-----			-	ACTR ASSY,RTRY:(SEE S2126 REPL) (ATTACHING PARTS)		
-138	211-0148-01			6	SCREW,MACHINE:4-40 X 0.312 INCH,PNH,SST	83385	OBD
-139	210-1002-00			6	WASHER,FLAT:0.125 ID X 0.25 INCH OD,BRS	12327	OBD
										-----*-----		
				-	ACTR ASSEMBLY INCLUDES:		
-140	214-1139-00			2	SPRING,FLAT:0.885 X 0.156CU BE GLD CLR	80009	214-1139-00
-141	214-1127-00			2	ROLLER,DETENT:0.125 DIA X 0.125,SST	80009	214-1127-00
-142	210-0406-00			4	NUT,PLAIN,HEX.:4-40 X 0.188 INCH,BRS	73743	12161-50
-143	401-0081-02			1	BEARING,CAM SW:FRONT (ATTACHING PARTS)	80009	401-0081-02
-144	354-0391-00			1	RING,RETAINING:0.395"FREE ID X 0.025" STL (ATTACHING PARTS)	97464	3100-43-CD
										-----*-----		
-145	105-0648-00			1	ACTUATOR,CAM SW:X.1-X1	80009	105-0648-00
-146	210-0406-00			4	NUT,PLAIN,HEX.:4-40 X 0.188 INCH,BRS	73743	12161-50
-147	401-0115-00			1	BEARING,CAM SW:CENTER	80009	401-0115-00
-148	131-0963-00			1	CONTACT,ELEC:GROUNDING	000EX	OBD
-149	214-1139-00			2	SPRING,FLAT:0.885 X 0.156CU BE GLD CLR	80009	214-1139-00
-150	214-1127-00			2	ROLLER,DETENT:0.125 DIA X 0.125,SST	80009	214-1127-00
-151	210-0406-00			4	NUT,PLAIN,HEX.:4-40 X 0.188 INCH,BRS	73743	12161-50
-152	401-0115-00			1	BEARING,CAM SW:CENTER (ATTACHING PARTS)	80009	401-0115-00
-153	354-0391-00			1	RING,RETAINING:0.395"FREE ID X 0.025" STL (ATTACHING PARTS)	97464	3100-43-CD
										-----*-----		
-154	105-0659-00			1	ACTUATOR,SWITCH:CAM SWITCH	80009	105-0659-00
-155	-----			1	CKT BOARD ASSY:MAIN(SEE A1 REPL)		
-156	337-2135-00			1	SHIELD,ELEC:PULSER,SAMPLER,REAR	80009	337-2135-00
-157	337-2157-00			1	SHIELD,ELEC:PULSER SAMPLER	80009	337-2157-00

Fig. & Index No.	Tektronix Part No.	Serial/Model No. Eff Dscont	Qty	1	2	3	4	5	Name & Description	Mfr Code	Mfr Part Number
2-158	337-2313-00		1	SHIELD,ELEC:CIRCUIT CARD, TOP (MOUNTED ON COMPONENT SIDE OF CKT BD) (ATTACHING PARTS)	80009	337-2313-00
-159	211-0008-00		3	SCREW,MACHINE:4-40 X 0.250,PNH,STL,CD PL	83385	OBD
-160	337-2314-00		1	SHIELD,ELEC:CIRCUIT CARD,BOTTOM (ATTACHING PARTS)	80009	337-2314-00
-161	210-0406-00		3	NUT,PLAIN,HEX.:4-40 X 0.188 INCH,BRS	73743	12161-50
-162	166-0233-00		3	SPACER,SLEEVE:0.312 L X 0.129 ID BRS	76854	3-5165-263
-163	129-0605-00		3	POST,ELEC-MECH:0.735 W/4-40 THD,INT/EXT,BRS	80009	129-0605-00
-164	129-0353-00		2	POST,ELEC-MECH:0.188 HEX X 0.385 INCH LONG (ATTACHING PARTS)	80009	129-0353-00
-165	211-0116-00		2	SCR,ASSEM WSHR:4-40 X 0.312 INCH,PNH BRS	83385	OBD
-166	131-0604-00		13	CONTACT,ELEC:CKT BD SW,SPR,CU BE	80009	131-0604-00
-167	131-0608-00		45	TERMINAL,PIN:0.365 L X 0.025 PH BRZ GOLD	22526	47357
	131-0827-00		2	CONTACT,ELEC:0.55 INCH LONG	22526	48283-028
-168	131-0993-00		1	BUS,CONDUCTOR:2 WIRE BLACK	00779	530153-2
-169	131-1003-00		2	CONN,RCPT,ELEC:CKT BD MT,3 PRONG	80009	131-1003-00
-170	131-1691-00		1	CONN,RCPT,ELEC:75K BNC	24931	28JR269-1
-171	136-0252-04	B010100 B061461	86	SOCKET,PIN TERM:U/W 0.016-0.018 DIA PINS	22526	75060-007
	136-0252-04	B061462 B082958X	100	SOCKET,PIN TERM:U/W 0.016-0.018 DIA PINS	22526	75060-007
-172	136-0269-02		2	SKT,PL-IN ELEK:MICROCIRCUIT,14 DIP,LOW CLE	73803	CS9002-14
-173	136-0514-00	B010100 B061461	4	SKT,PL-IN ELEC:MICROCIRCUIT,8 DIP	73803	CS9002-8
	136-0514-00	B061462 B082958X	2	SKT,PL-IN ELEC:MICROCIRCUIT,8 DIP	73803	CS9002-8
-174	214-0579-00		4	TERM,TEST POINT:BRS CD PL	80009	214-0579-00
-175	343-0495-01		2	CLIP,SWITCH:FRONT,7.5 MM,1 UNIT (ATTACHING PARTS)	80009	343-0495-01
-176	210-3050-00		1	EYELET,METALLIC:0.218 L X 0.059 OD,BRS	07707	SE-27
-177	343-0499-01		2	CLIP,SWITCH:REAR,7.5 MM,1 UNIT (ATTACHING PARTS)	80009	343-0499-01
-178	210-3050-00		1	EYELET,METALLIC:0.218 L X 0.059 OD,BRS	07707	SE-27
-179	343-0496-02		1	CLIP,SWITCH:FRONT (ATTACHING PARTS)	80009	343-0496-02
-180	210-3033-00		2	EYELET,METALLIC:0.59 OD X 0.156 INCH LONG	07707	SE-25
-181	343-0497-02		1	CLIP,SWITCH:REAR (ATTACHING PARTS)	80009	343-0497-02
-182	210-3033-00		2	EYELET,METALLIC:0.59 OD X 0.156 INCH LONG	07707	SE-25
-183	343-0496-03		1	CLIP,SWITCH:FRONT,10 MM X 3 UNIT (ATTACHING PARTS)	80009	343-0496-03
-184	210-3033-00		3	EYELET,METALLIC:0.59 OD X 0.156 INCH LONG	07707	SE-25
-185	343-0497-03		1	CLIP,SWITCH:REAR,10 MM X 3 UNIT (ATTACHING PARTS)	80009	343-0497-03
-186	210-3033-00		3	EYELET,METALLIC:0.59 OD X 0.156 INCH LONG	07707	SE-25
-187	131-0707-00		15	CONNECTOR,TERM:22-26 AWG,BRS& CU BE GOLD	22526	47439
-188	352-0169-01		1	HLDR TERM CONN:2 WIRE,BROWN	80009	352-0169-01
	352-0169-05		1	CONN BODY,PL,EL:2 WIRE GREEN	80009	352-0169-05
-189	352-0165-04		1	CONN BODY,PL,EL:7 WIRE YELLOW	80009	352-0165-04
-190	352-0162-09		1	CONN BODY,PL,EL:4 WIRE WHITE	80009	352-0162-09
-191	210-0774-00		1	EYELET,METALLIC:0.152 OD X 0.245 INCH L,BRS	80009	210-0774-00
-192	210-0775-00		1	EYELET,METALLIC:0.126 OD X 0.23 INCH L,BRS	80009	210-0775-00
-193	175-0830-00		FT	WIRE,ELECTRICAL:7 WIRE RIBBON	08261	SS-0726-710610C
	162-0510-00		FT	INSUL,SLVG,ELEC:0.34 ID,RED,0.016 FT L	93410	F5B2021
	162-0520-00		FT	INSUL,SLVG,ELEC:0.34 ID,GREEN,0.016 FT L	93410	F5B2031
	162-0576-00		FT	INSUL,SLVG,ELEC:0.34 ID,ORANGE,0.016 FT L	93410	F5B2071
	162-0578-00		FT	INSUL,SLVG,ELEC:0.34 ID,VIOLET,0.016 FT L	93410	F5B20V1

Replaceable Mechanical Parts—1503

Fig. & Index No.	Tektronix Part No.	Serial/Model No. Eff Dscont	Qty	1	2	3	4	5	Name & Description	Mfr Code	Mfr Part Number
2-194	220-0547-01		2						NUT,BLOCK:0.38 X 0.26 X0.282 (2)4-40 THD (ATTACHING PARTS)	000FW	OBD
-195	211-0101-00		2						SCREW,MACHINE:4-40 X 0.25,100 DEG,FLH STL - - - * - - -	83385	OBD
	198-2257-00		1						WIRE SET,ELEC:	80009	198-2257-00
-196	131-0707-00		37						. CONNECTOR,TERM:22-26 AWG,BRS& CU BE GOLD	22526	47439
	352-0169-02		1						. CONN BODY,PL,EL:2 WIRE RED	80009	352-0169-00
	352-0169-04		1						. CONN BODY,PL,EL:2 WIRE YELLOW	80009	352-0169-04
-198	352-0161-01		1						. CONN BODY,PL,EL:3 WIRE BROWN	80009	352-0161-01
	352-0161-05		2						. CONN BODY,PL,EL:3 WIRE GREEN	80009	352-0161-05
-199	352-0165-03		1						. CONN BODY,PL,EL:7 WIRE ORANGE	80009	352-0165-03
	352-0165-06		1						. CONN BODY,PL,EL:7 WIRE BLUE	80009	352-0165-06
-200	352-0164-02		1						. CONN BODY,PL,EL:6 WIRE RED	80009	352-0164-02
	352-0164-07		1						. HLD,TERM CONN:6 WIRE VIOLET	80009	352-0164-07
-201	175-0825-00		FT						. WIRE,ELECTRICAL:2 WIRE RIBBON	80009	175-0825-00
-202	175-0826-00		FT						. WIRE,ELECTRICAL:3 WIRE RIBBON	80009	175-0826-00
-203	175-0829-00		FT						. WIRE,ELECTRICAL:6 WIRE RIBBON	08261	SS-0626-710610C
-204	175-0830-00		FT						. WIRE,ELECTRICAL:7 WIRE RIBBON	08261	SS-0726-710610C

Fig. & Index No.	Tektronix Part No.	Serial/Model No. Eff Dscont	Qty	1 2 3 4 5	Name & Description	Mfr Code	Mfr Part Number
3-1	337-2194-00		1		SHIELD,ELEC:EMI, TOP	80009	337-2194-00
-2	342-0309-00		1		INSULATOR,FILM:EMI, TOP, PLASTIC	80009	342-0309-00
-3	337-2193-00		1		SHIELD,ELEC:EMI,BOTTOM	80009	337-2193-00
-4	342-0310-00		1		INSULATOR,FILM:EMI,BOTTOM;PLASTIC	80009	342-0310-00
	016-0606-00		1		MODULE:X-Y OUTPUT	80009	016-0606-00
-5	131-1726-00		3		. JACK,TIP:BLACK,W/HARDWARE	83330	256-103
-6	131-1726-01		3		. JACK,TIP:RED,W/HARDWARE	83330	21293-RED
-7	366-1368-00		2		. KNOB:PLUG-IN,SECURING	80009	366-1368-00
			-		. EACH KNOB INCLUDES:		
	213-0076-00		1		. . SETSCREW:2-56 X 0.125 INCH,HEX.SOC STL	74445	OBD
-8	384-1349-00		2		. PIN,STR,THD:0.125 DIA X 6.417" LONG (ATTACHING PARTS)	80009	384-1349-00
-9	210-1011-00		2		. WASHER,NONMETAL:0.13 ID X 0.375 " OD,PLSTC	83309	OBD
-10	354-0538-00		2		. PACKING,PREFMD:0.119 ID X 0.125" OD,NPRN	07322	8006-366Y
-11	210-0803-00		2		. WASHER,FLAT:0.15 ID X 0.032 THK,STL CD PL	12327	OBD
			-		. PIN INCLUDES:		
-12	354-0163-00		1		. . RING,RETAINING:TRUAR,CAD PLATE	79136	5133-12MD
			-		- - - * - - -		
-13	333-2021-00		1		. PANEL,FRONT:	80009	333-2021-00
-14	386-3229-00	B010100 B030819	1		. SUBPANEL,FRONT:	80009	386-3229-00
	386-3229-03	B030820	1		. SUBPANEL,FRONT: (ATTACHING PARTS)	80009	386-3229-03
-15	211-0101-00		4		. SCREW,MACHINE:4-40 X 0.25,100 DEG,FLH STL	83385	OBD
			-		- - - * - - -		
-16	-----		1		. CKT BOARD ASSY:X-Y PLUG-IN(SEE A7 REPL) (ATTACHING PARTS)		
-17	211-0116-00		4		. SCR,ASSEM WSHR:4-40 X 0.312 INCH,PNH BR	83385	OBD
			-		- - - * - - -		
			1		. CKT BOARD ASSY INCLUDES:		
-18	131-0608-00		3		. . TERMINAL,PIN:0.365 L X 0.025 PH BRZ GOLD	22526	47357
-19	131-0993-00		1		. . BUS,CONDUCTOR:2 WIRE BLACK	00779	530153-2
-20	136-0220-00	B010100 B082958X	1		. . SKT,PL-IN ELEK:TRANSISTOR 3 CONTACT,PCB MT	71785	133-23-11-034
-21	407-1633-00		1		. BRACKET,FR SECT:ALUMINUM (ATTACHING PARTS)	80009	407-1633-00
-22	211-0101-00		2		. SCREW,MACHINE:4-40 X 0.25,100 DEG,FLH STL	83385	OBD
			-		- - - * - - -		
-23	220-0547-01		4		. NUT,BLOCK:0.38 X 0.26 X0.282 (2)4-40 THD (ATTACHING PARTS)	000FW	OBD
-24	211-0101-00		4		. SCREW,MACHINE:4-40 X 0.25,100 DEG,FLH STL	83385	OBD
			-		- - - * - - -		
-25	426-1204-00		2		. FRAME SECTION:LEFT AND RIGHT	80009	426-1204-00
	334-1418-00		1		PLATE,INDENT:BLANK	80009	334-1418-00
-26	426-1187-02		1		SUBPANEL,FRONT:	80009	46-1187-02
	426-1495-00		1		FRAME PNL,CAB.:FRONT	80009	426-1495-00
			-		(OPTION 1 ONLY) (ATTACHING PARTS)		
-27	213-0718-00		1		SCR,TPG,THD FOR:6-20 X 0.625 INCH,OVH STL	83385	OBD
-28	213-0227-00		5		SCR,TPG,THD FOR:6-32 X 0.50 DEG,FLH ST	83385	OBD
			-		- - - * - - -		
	337-2206-00	B010100 B083249	1		SHLD,IMPLOSION:CRT,CLEAR	80009	337-2206-00
	337-2206-02	B083250	1		SHLD,IMPLOSION:CRT	80009	337-2206-02
-29	-----		1		CKT BOARD ASSY:OUTPUT AMP(SEE A3 REPL) (ATTACHING PARTS)		
-30	213-0088-00		4		SCR,TPG,THD CTG:4-24 X 0.25 INCH,PNH STL	83385	OBD
			-		- - - * - - -		
			-		CKT BOARD ASSEMBLY INCLUDES:		
-31	136-0252-04	B010100 B082958X	27		. SOCKET,PIN TERM:U/W 0.016-0.018 DIA PINS	22526	75060-007
-32	136-0269-02	B010100 B082958X	2		. SKT,PL-IN ELEK:MICROCIRCUIT,14 DIP,LOW CLE	73803	CS9002-14
-33	131-0608-00		22		. TERMINAL,PIN:0.365 L X 0.025 PH BRZ GOLD	22526	47357
	131-0589-00		5		. TERMINAL,PIN:0.46 L X 0.025 SQ	22526	48283-029
-34	346-0127-00		2		STRAP,TIE DOWN:4.0" L X 0.091" WIDE	59730	TY53M
-35	214-1756-00		1		ACTUATOR,SWITCH:POWER	80009	214-1756-00
-36	-----		1		SWITCH,TOGGLE:(SEE S0165 REPL)		
-37	210-0269-00		1		TERMINAL,LUG:NON LOCKING,0.257" MTG HOLE	78584	905-020
-38	407-1590-00		1		BRACKET,ANGLE:POWER SWITCH,ALUMINUM (ATTACHING PARTS)	80009	407-1590-00
-39	211-0101-00		2		SCREW,MACHINE:4-40 X 0.25,100 DEG,FLH STL	83385	OBD
			-		- - - * - - -		

Replaceable Mechanical Parts—1503

Fig. & Index No.	Tektronix Part No.	Serial/Model No. Eff Dscont	Qty	1	2	3	4	5	Name & Description	Mfr Code	Mfr Part Number
3-40	351-0436-00		1						GUIDE, PL-IN UNI: UPPER RIGHT (ATTACHING PARTS)	80009	351-0436-00
-41	213-0192-00		1						SCR, TPG, THD FOR: 6-32 X 0.50 INCH, PNH STL - - - * - - -	87308	OBD
-42	-----		1						CKT BOARD ASSY: LOGIC (SEE A5 REPL) (ATTACHING PARTS)		
-43	211-0008-00		4						SCREW, MACHINE: 4-40 X 0.250, PNH, STL, CD PL - - - * - - -	83385	OBD
-44	131-0589-00		-						CKT BOARD ASSEMBLY INCLUDES:		
-45	136-0514-00	B010100 B082958X	16						. TERMINAL, PIN: 0.46 L X 0.025 SQ	22526	48283-029
-46	136-0269-02	B010100 B082958X	1						. SKT, PL-IN ELEC: MICROCIRCUIT, 8 DIP	73803	CS9002-8
-47	136-0252-04	B010100 B082958X	4						. SKT, PL-IN ELEC: MICROCIRCUIT, 14 DIP, LOW CLE	73803	CS9002-14
-48	136-0263-04	B010100 B082958X	47						. SOCKET, PIN TERM: U/W 0.016-0.018 DIA PINS	22526	75060-007
-49	136-0260-02	B010100 B082958X	10						. SOCKET, PIN TERM: FOR 0.025 INCH SQUARE PIN	22526	75377-001
-50	214-0579-00		1						. SKT, PL-IN ELEC: MICROCIRCUIT, 16 DIP, LOW CLE	71785	133-51-92-008
	162-0504-00		7						. TERM, TEST POINT: BRS CD PL	80009	214-0579-00
	162-0510-00		FT						. INSUL SLVG, ELEC: 0.034 ID, BLACK, 0.016 FT LONG	93410	F5B2011
	162-0516-00		FT						. INSUL SLVG, ELEC: 0.034 ID, RED, 0.016 FT LONG	93410	F5B2021
	162-0520-00		FT						. INSUL SLVG, ELEC: 0.034 ID, YELLOW, 0.016 FT LONG	93410	F5B2041
	162-0524-00		FT						. INSUL SLVG, ELEC: 0.034 ID, GREEN, 0.016 FT LONG	93410	F5B2031
	162-0576-00		FT						. INSUL SLVG, ELEC: 0.034 ID, BLUE, 0.016 FT LONG	93410	F5B2051
	162-0578-00		FT						. INSUL SLVG, ELEC: 0.034 ID, ORANGE, 0.016 FT LONG	93410	F5B2071
-51	220-0729-00		1						. INSUL SLVG, ELEC: 0.034 ID, VIOLET, 0.016 FT LONG	93410	F5B20V1
			1						NUT BLOCK: 0.25 X 0.471 INCH LONG (ATTACHING PARTS)	80009	220-0729-00
-52	211-0101-00		1						SCREW, MACHINE: 4-40 X 0.25, 100 DEG, FLH STL - - - * - - -	83385	OBD
	334-2452-00		1						MARKER, IDENT: MKD DANGER 165V	80009	334-2452-00
-53	351-0435-00		1						GUIDE, PL-IN: LOVER LEFT (ATTACHING PARTS)	80009	351-0435-00
-54	213-0192-00		1						SCR, TPG, THD FOR: 6-32 X 0.50 INCH, PNH STL - - - * - - -	87308	OBD
-55	131-1165-00		1						CONNECTOR, RCPT, : 15 PIN FEMALE, FLOATING (ATTACHING PARTS)	71468	DAF-15S
-56	211-0034-00		2						SCREW, MACHINE: 2-56 X 0.50 INCH, PNH	83385	OBD
-57	361-0742-00		2						SPACER, SLEEVE: 0.094 ID X 0.2 INCH LONG - - - * - - -	80009	361-0742-00
-58	134-0014-00		2						PLUG, TIP: MALE (ATTACHING PARTS)	74970	023-0026-001
-59	210-0457-00		2						NUT, PL, ASSEM WA: 6-32 X 0.312, STL CD PL	83385	OBD
-60	210-0202-00		2						TERMINAL, LUG: 0.146 ID, LOCKING, BRZ TINNED	78189	2104-06-00-2520N
-61	210-0975-00		2						WSHR, SHOULDERED: 0.14 ID X 0.247" OD, PLSTC	80009	210-0975-00
-62	210-0933-00		2						WASHER, NONMETAL: 0.625" DIA, 0.002 MICA - - - * - - -	08530	OBD
-63	343-0089-00		1						CLAMP, LOOP: LARGE	80009	343-0089-00
-64	343-0213-00		1						CLAMP, LOOP: 0.2 ID, PLASTIC	80009	343-0213-00
-65	348-0064-00		1						GROMMET, PLASTIC: 0.625 INCH DIA	80009	348-0064-00
-66	348-0417-00		1						GROMMET, PLASTIC: 0.75 INCH DIA	80009	348-0417-00
-67	-----		1						CKT BOARD ASSY: POWER (SEE A6 REPL) (ATTACHING PARTS)		
-68	211-0008-00		4						SCREW, MACHINE: 4-40 X 0.250, PNH, STL, CD PL - - - * - - -	83385	OBD
-69	136-0514-00	B010100 B082958X	-						CKT BOARD ASSEMBLY INCLUDES:		
-70	136-0252-04	B010100 B082958X	4						. SKT, PL-IN ELEC: MICROCIRCUIT, 8 DIP	73803	CS9002-8
	136-0352-00		42						. SOCKET, PIN TERM: U/W 0.016-0.018 DIA PINS	22526	75060-007
-71	131-0589-00		8						. CONTACT, ELEC: FOR 0.02 INCH DIAMETER PIN	00779	50462-7
-72	131-0608-00		5						. TERMINAL, PIN: 0.46 L X 0.025 SQ	22526	48283-029
	131-0590-00		21						. TERMINAL, PIN: 0.365 L X 0.025 PH BRZ GOLD	22526	47357
-73	214-0579-00		2						. CONTACT, ELEC: 0.71 INCH LONG	22526	47351
	334-2451-00		7						. TERM, TEST POINT: BRS CD PL	80009	214-0579-00
-74	-----		1						MARKER, IDENT: MKD DANGER 2KV	80009	334-2451-00
			1						CKT BOARD ASSY: SWEEP GEN (SEE A4 REPL) (ATTACHING PARTS)		
-75	211-0116-00		4						SCR, ASSEM WSHR: 4-40 X 0.312 INCH, PNH BRS - - - * - - -	83385	OBD

Fig. & Index No.	Tektronix Part No.	Serial/Model No. Eff Dscont	Qty	1	2	3	4	5	Name & Description	Mfr Code	Mfr Part Number
3-	-----		-						CKT BOARD ASSEMBLY INCLUDES:		
-76	136-0252-04	B010100 B082958X	6						. SOCKET, PIN TERM:U/W 0.016-0.018 DIA PINS	22526	75060-007
-77	131-0589-00		7						. TERMINAL, PIN:0.46 L X 0.025 SQ	22526	48283-029
-78	131-0608-00		5						. TERMINAL, PIN:0.365 L X 0.025 PH BRZ GOLD	22526	47357
-79	214-0579-00		2						. TERM, TEST POINT: BRS CD PL	80009	214-0579-00
-80	129-0541-00		1						POST, ELEC-MECH: 1.53" L W/4-40 THD, NYLON	80009	129-0541-00
	334-2501-00		1						MARKER, IDENT: MKD CAUTION 48 TO 410HZ	80009	334-2501-00
-81	-----		1						XFMR, PWR, STPDN: (SEE T0389 REPL) (ATTACHING PATRTS)		
-82	210-0457-00		1						NUT, PL, ASSEM WA: 6-32 X 0.312, STL CD PL	83385	OBD
-83	210-0202-00		1						TERMINAL, LUG: 0.146 ID, LOCKING, BRZ TINNED	78189	2104-06-00-2520N
-84	211-0529-00		1						SCREW, MACHINE: 6-32 X 1.25 INCHES, PNH STL	83385	OBD
-85	211-0628-00		3						SCREW, MACHINE: 6-32 X 1.125 INCH, PNH, STL	83385	OBD
-86	210-1133-00		4						WASHER, FLAT: 0.142 ID X 0.058 THK, FBR - - - * - - -	80009	210-1133-00
-87	358-0329-00		10						BSHG, FEED THRU: FUSEHOLDER TERM, DELRIN	80009	358-0329-00
-88	131-0513-03		10						TERM, FEEDTHRU: 0.89 L X 0.025 SQ EA END	00779	1-86074-3
-89	131-1360-00		1						CONN, RCPT, ELEC: CKT BD, 10/20 CONTACT (ATTACHING PARTS)	05574	600201-3197
-90	210-0406-00		2						NUT, PLAIN, HEX.: 4-40 X 0.188 INCH, BRS	73743	12161-50
-91	210-0201-00		2						TERMINAL, LUG: 0.12 ID, LOCKING, BRZ TIN PL	86928	OBD
-92	211-0014-00		2						SCREW, MACHINE: 4-40 X 0.50 INCH, PNH STL - - - * - - -	83385	OBD
-93	220-0547-01		1						NUT, BLOCK: 0.38 X 0.26 X 0.282 (2)4-40 THD (ATTACHING PARTS)	000FW	OBD
-94	211-0008-00		1						SCREW, MACHINE: 4-40 X 0.250, PNH, STL, CD PL - - - * - - -	83385	OBD
-95	441-1262-00		1						CHAS, TDR UNIT: MAIN (ATTACHING PARTS)	80009	441-1262-00
-96	211-0008-00		8						SCREW, MACHINE: 4-40 X 0.250, PNH, STL, CD PL - - - * - - -	83385	OBD
-97	256-0570-00		1						SILICA, PULVERIZ: 2.375 INCH DIA (ATTACHING PARTS)	87664	X1009-43G
-98	211-0513-00		1						SCREW, MACHINE: 6-32 X 0.625 INCH, PNH STL	83385	OBD
-99	210-0055-00		1						WASHER, LOCK: SPLIT, 0.145 ID X 0.253 OD, STL	83385	OBD
-100	407-1694-00		1						BRACKET, RTNR: ALUMINUM - - - * - - -	80009	407-1694-00
-101	129-0562-00		1						POST, RETAINER: 0.892 INCH LONG X 0.375 HEX (ATTACHING PARTS)	80009	129-0562-00
-102	211-0097-00		1						SCREW, MACHINE: 4-40 X 0.312 INCH, PNH STL	83385	OBD
	211-0033-00		1						SCR, ASSEM WSHR: 4-40 X 0.312 PNH, STL, CD PL - - - * - - -	83385	OBD
-103	131-1084-01		1						CONNECTOR, RCPT, : 3 BLADE, 6A, 250V, W/0.203 ID (ATTACHING PARTS)	80009	131-1084-01
-104	210-0586-00		2						NUT, PL, ASSEM WA: 4-40 X 0.25, STL CD PL	83385	OBD
-105	211-0012-00		2						SCREW, MACHINE: 4-40 X 0.375, PNH STL CD PL	83385	OBD
-106	210-0994-00		2						WASHER, FLAT: 0.125 ID X 0.25" OD, STL	86928	5702-201-20
-107	361-0764-00		2						SPACER, SLEEVE: 0.135 INCH L X 0.132 ID, BRS - - - * - - -	80009	361-0764-00
-108	220-0547-01		3						NUT, BLOCK: 0.38 X 0.26 X 0.282 (2)4-40 THD (ATTACHING PARTS)	000FW	OBD
-109	211-0101-00		3						SCREW, MACHINE: 4-40 X 0.25, 100 DEG, FLH STL - - - * - - -	83385	OBD
-110	210-0202-00		1						TERMINAL, LUG: 0.146 ID, LOCKING, BRZ TINNED (ATTACHING PARTS)	78189	2104-06-00-2520N
-111	210-0457-00	B010100 B059999	1						NUT, PL, ASSEM WA: 6-32 X 0.312, STL CD PL	83385	OBD
	210-0407-00	B060000	2						NUT, PLAIN, HEX.: 6-32 X 0.25 INCH, BRS	73743	3038-0228-402
-112	211-0507-00		1						SCREW, MACHINE: 6-32 X 0.312 INCH, PNH STL - - - * - - -	83385	OBD
	334-2529-00		1						MARKER, IDENT: MKD CAUTION, BATTERY PACK	80009	334-2529-00
-113	386-3154-01		1						PANEL, REAR: (ATTACHING PARTS)	80009	386-3154-01
-114	213-0192-00		5						SCR, TPG, THD FOR: 6-32 X 0.50 INCH, PNH STL - - - * - - -	87308	OBD

Replaceable Mechanical Parts—1503

Fig. & Index No.	Tektronix Part No.	Serial/Model No. Eff Dscont	Qty	1 2 3 4 5	Name & Description	Mfr Code	Mfr Part Number
3-115	426-1184-00		1		FRAME SECT,TDR:LEFT	80009	426-1184-00
-116	426-1185-00		1		FRAME SECT,TDR:CENTER	80009	426-1185-00
-117	426-1186-00		1		FRAME SECT,TDR:RIGHT	80009	426-1186-00
-118	179-2178-00	B010100 B040879	1		WIRING HARNESS,:FRONT PANEL	80009	179-2178-00
	179-2178-01	B040880	1		WIRING HARNESS,:FRONT PANEL	80009	179-2178-01
-119	131-0707-00		34		. CONNECTOR,TERM:22-26 AWG,BRS& CU BE GOLD	22526	47439
-120	352-0169-03		1		. CONN BODY,PL,EL:2 WIRE ORANGE	80009	352-0169-03
	352-0169-06		1		. CONN BODY,PL,EL:2 WIRE BLUE	80009	352-0169-06
-121	352-0161-01		1		. CONN BODY,PL,EL:3 WIRE BROWN	80009	352-0161-01
	352-0162-02		2		. CONN BODY,PL,EL:4 WIRE RED	80009	352-0162-02
	352-0161-06		1		. CONN BODY,PL,EL:3 WIRE BLUE	80009	352-0161-06
	352-0161-07		1		. CONN BODY,PL,EL:3 WIRE VIOLET	80009	352-0161-07
-122	352-0165-03		1		. CONN BODY,PL,EL:7 WIRE ORANGE	80009	352-0165-03
	352-0165-07		1		. CONN BODY,PL,EL:7 WIRE VIOLET	80009	352-0165-07
	198-2386-00		1		WIRE SET,ELEC:	80009	198-2386-00
	131-0707-00		7		. CONNECTOR,TERM:22-26 AWG,BRS& CU BE GOLD	22526	47439
	131-0621-00		3		. CONNECTOR,TERM:22-26 AWG,BRS& CU BE GOLD	22526	46231
-123	352-0171-04		1		. CONN BODY,PL,EL:1 WIRE YELLOW	80009	352-0171-04
	352-0161-01		1		. CONN BODY,PL,EL:3 WIRE BROWN	80009	352-0161-01
	352-0161-09		1		. CONN BODY,PL,EL:3 WIRE WHITE	80009	352-0161-09
-124	352-0199-03		1		. CONN BODY,PL,EL:3 WIRE ORANGE	80009	352-0199-03
	198-2796-00		1		WIRE SET,ELEC:	80009	198-2796-00
	131-0707-00		9		. CONNECTOR,TERM:22-26 AWG,BRS& CU BE GOLD	22526	47439
	175-0830-00		FT		. WIRE,ELECTRICAL:7 WIRE RIBBON	08261	SS-0726-710610C
	352-0165-04		1		. CONN BODY,PL,EL:7 WIRE YELLOW	80009	352-0165-04
	352-0169-01		1		. HLDR TERM CONN:2 WIRE,BROWN	80009	352-0169-01
	179-2349-00	B010100 B082957	1		WIRING HARNESS,:AC	80009	179-2349-00
	175-2492-00	B082958	1		CA ASSY,SP,ELEC:4,22 AWG,17.0L	80009	175-2492-00
	195-0389-00	XB082959	1		LEAD,ELECTRICAL:18 AWG,4.0 L,5-4	80009	195-0389-00

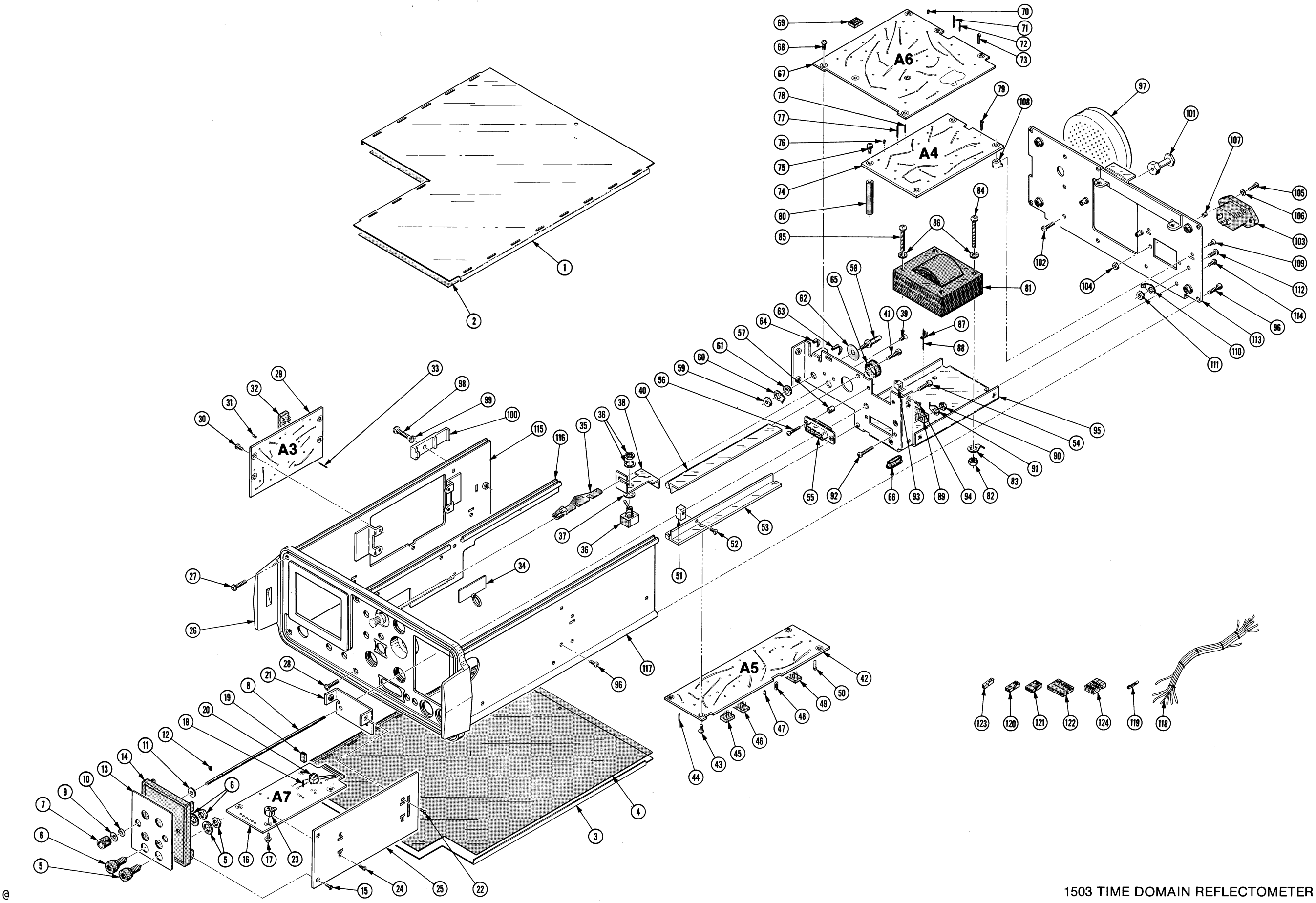

a

1503 TIME DOMAIN REFLECTOMETER

FIG. 3 FRAME & CIRCUIT BOARD ASSEMBLIES

FIG. 4. BATTERY PACK

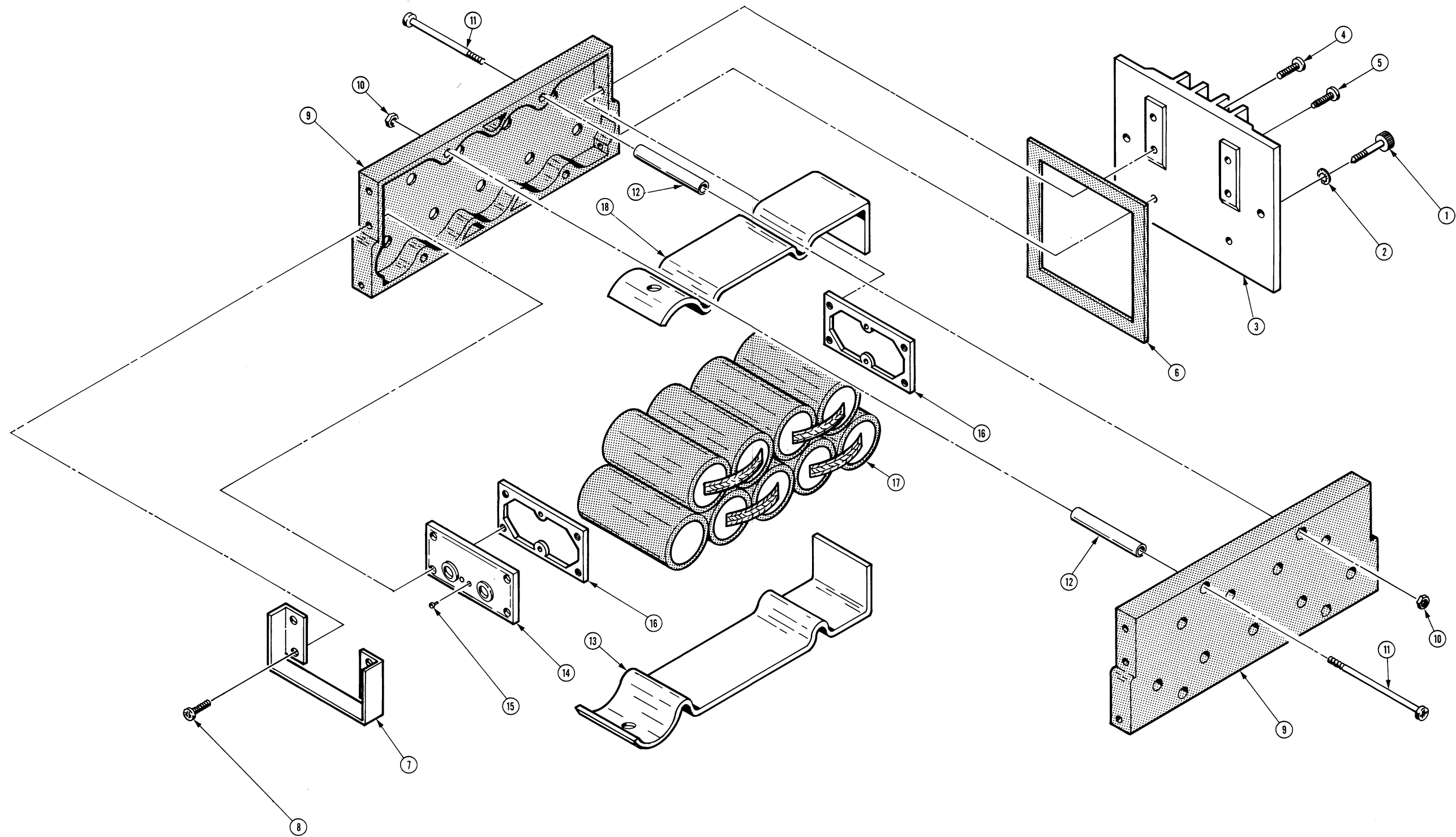

Fig. & Index No.	Tektronix Part No.	Serial/Model No. Eff Dscont	Qty	1 2 3 4 5	Name & Description	Mfr Code	Mfr Part Number
4-	016-0595-00	B010100 B089999	1	.	BATTERY SET:	80009	016-0595-00
	016-0595-01	B090000	1	.	BATTERY SET:	80009	016-0595-01
					(ATTACHING PARTS)		
-1	214-1573-00		2	.	THUMBSCREW:6-32 X 0.656 INCH LONG,SST	06540	6130-SS-0632
-2	210-1160-00		2	.	WASHER,NONMETAL:0.109 ID X 0.25 INCH OD	86445	OBD
					- - - * - - -		
	-----		-	.	BATTERY PACK ASSY INCLUDES:		
-3	333-1990-00		1	.	PANEL,FRONT:	80009	333-1990-00
					(ATTACHING PARTS)		
-4	211-0198-00		4	.	SCREW,MACHINE:4-40 X 0.438 PNH,STL,POZ	77250	OBD
-5	213-0267-00		2	.	SCREW,MACHINE:4-24 X 0.375 INCH,PNH STL	83385	OBD
					- - - * - - -		
-6	348-0432-00		1	.	GASKET:FRONT PANEL	80009	348-0432-00
-7	337-2762-00		1	.	SHIELD,FUSE:ALUMINUM	80009	337-2762-00
					(ATTACHING PARTS)		
-8	211-0008-00		4	.	SCREW,MACHINE:4-40 X 0.250,PNH,STL,CD PL	83385	OBD
					- - - * - - -		
-9	343-0349-01		2	.	CLAMP,BTRY RTNG:W/HOLES	80009	343-0349-01
					(ATTACHING PARTS)		
-10	210-0406-00		4	.	NUT,PLAIN,HEX.:4-40 X 0.188 INCH,BRS	73743	12161-50
-11	211-0194-00		4	.	SCREW,MACHINE:4-40 X 47.5MM,PNH,ST	0000M	211-0194-00
					- - - * - - -		
-12	361-0776-00		4	.	SPACER,SLEEVE:1.248 L X 0.118 ID,NYLON	80009	361-0776-00
-13	214-2344-00		1	.	HEAT SINK,ELEC:BATTERY SUPPLY,LOWER,AL	80009	214-2344-00
-14	-----		1	.	CKT BOARD ASSY:POWER FUSE JACK(SEE A9 REPL)		
-15	136-0352-00		4	.	CONTACT,ELEC:FOR 0.02 INCH DIAMETER PIN	00779	50462-7
-16	386-2435-00		2	.	PLATE,METALLIC:W/TAPS	0000M	386-2435-00
-17	146-0018-01		1	.	BATTERY SET:10.8V,1.5AH,9C CELLS	19209	41B002K33G1
-18	214-2343-00		1	.	HEAT SINK,ELEC:BATTERY SUPPLY,UPPER,AL	80009	214-2343-00



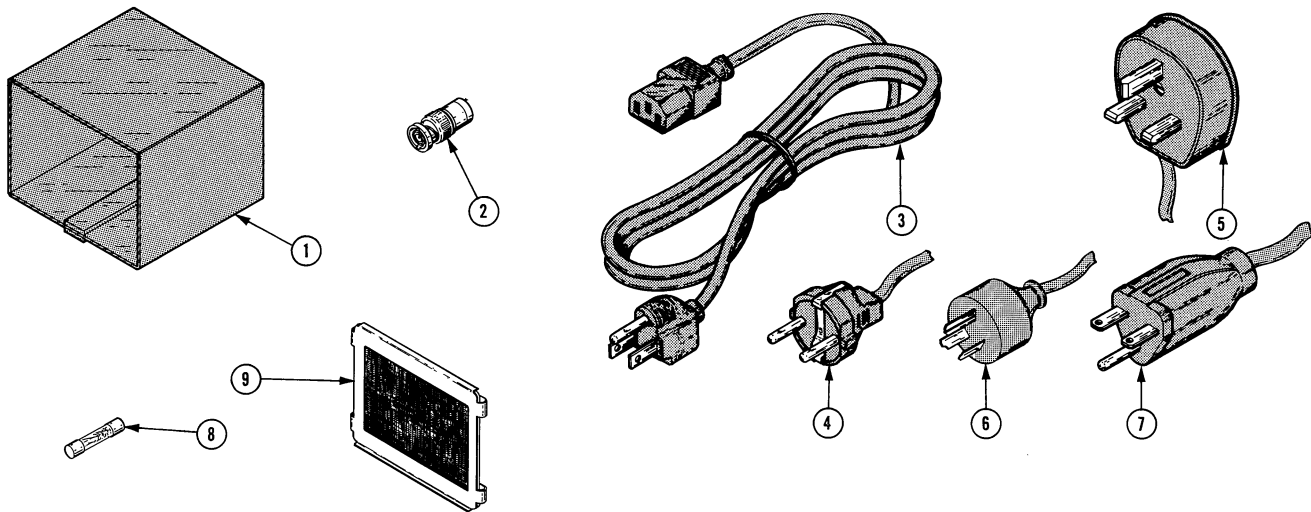

Fig. &
Index
No.

Tektronix
Part No.

Serial/Model No.
Eff Dscont

Qty

1 2 3 4 5

Name & Description

Mfr
Code

Mfr Part Number

STANDARD ACCESSORIES

-1	016-0297-00			1	VISOR,CRT:	80009	016-0297-00
-2	011-0123-00			1	CONNECTOR,PLUG,:50 OHM,BNC	80009	011-0123-00
-3	161-0066-00			1	CABLE ASSY,PWR,:3,18 AWG,115V,98.0 L	16428	KH8481
-4	161-0066-09	XB102860		1	CABLE ASSY,PWR:3,0.75MM SQ,220V,96.0 L - (OPTION A1 EUROPEAN ONLY)	80126	OBD
-5	161-0066-10	XB102860		1	CABLE ASSY,PWR:3,0.75MM SQ,240V,96.0 L - (OPTION A2 UNITED KINGDOM ONLY)	80126	OBD
-6	161-0066-11	XB102860		1	CABLE ASSY,PWR:3,0.75MM,240V,96.0L - (OPTION A3 AUSTRALIAN ONLY)	S3109	OBD
-7	161-0066-12	XB102860		1	CABLE ASSY,PWR:3,18 AWG,240V,96.0 L - (OPTION A4 NORTH AMERICAN ONLY)	80126	OBD
-8	159-0029-00	B010100	B049999	1	FUSE,CARTRIDGE:3AG,0.3A,250V,SLOW-BLOW	71400	MDL3/10
	159-0032-00	B050000		1	FUSE,CARTRIDGE:3AG,0.5A,250V,SLOW-BLOW	71400	MDL 1/2
	159-0054-00	B010100	B049999	1	FUSE,CARTRIDGE:3AG,0.15A,250V,SLOW-BLOW	71400	MDL 15/100
	159-0029-01	B050000		1	FUSE,CARTRIDGE:BUSSMAN ONLY	71400	MDL3/10
-9	378-0055-00			1	FILTER,MESH:CRT	80009	378-0055-00
	016-0606-00			1	MODULE:X-Y OUTPUT	80009	016-0606-00
	070-1864-01			1	MANUAL,TECH:OPERATORS	80009	070-1864-01
	070-1865-01			1	MANUAL,TECH:INSTRUCTION	80009	070-1865-01
	012-0671-02	XB020320		1	CABLE,INTCON:108.0 INCHES L	80009	012-0671-02
	003-0700-01	XB040840		1	RULE,SLIDE:TIME DOMAIN REFLECTOMETER	80009	003-0700-01

OPTIONAL ACCESSORIES

011-0102-00				1	TERMN,COAXIAL:75 OHM,BNC	80009	011-0102-00
013-0076-00				1	ADAPTER,CONN:BNC FEMALE TO CLIP LEADS	80009	013-0076-00
016-0327-00				1	ADAPTER,CAMERA:EXTENSION	80009	016-0327-00
017-0063-00				1	ADAPTER,CONN:BNC TO GR	24655	0874-9700
017-0064-00				1	ADAPTER,CONN:TYPE BNC TO GR,MALE	24655	0874-9800-QBPA
017-0090-00				1	FIXTURE,CAL:50 OHM TO 125OHM	80009	017-0090-00
017-0091-00				1	FIXTURE,CAL:50 OHM TO 75 OHM	80009	017-0091-00
017-0092-00				1	ADPTR,TDR IMPD:50 OHM TO 93 OHM	80009	017-0092-00
103-0015-00				1	ADAPTER,CONN:BNC TO UHF	95712	470-3NT34
103-0090-00				1	ADAPTER,CONN:FEMALE TO DUAL MALE BANANA	05276	1269
103-0029-00				1	ADAPTER,CONN:BNC MALE TO MALE	80009	103-0029-00
103-0032-00				1	ADAPTER,CONN:BNC MALE TO UHF FEMALE	24931	29-JP116-1
103-0035-00				1	ADAPTER,CONN:BNC DUAL BINDING POST	05276	1296
103-0058-00				1	ADAPTER,CONN:N FEMALE TO BNC MALE	91836	KN99-46TR5
103-0169-00				1	ADAPTER,CONN:PROBE	80009	103-0169-00
012-0671-03	XB020320			1	CABLE,INTCON:360.0 INCHES L	80009	012-0671-03
013-0169-00	XB020320			1	ADAPTER ASSY:ISLN XFMR,BALANCED OUTPUT	80009	013-0169-00
015-0327-00				1	FILTER,DIR CUR:	80009	015-0327-00

1
2
3
4
5
6
7
8
9
10
11
12
13
14
15
16
17
18
19
20
21
22
23
24
25
26
27
28
29
30
31
32
33
34
35
36
37
38
39
40
41
42
43
44
45
46
47
48
49
50
51
52
53
54
55
56
57
58
59
60
61
62
63
64
65
66
67
68
69
70
71
72
73
74
75
76
77
78
79
80
81
82
83
84
85
86
87
88
89
90
91
92
93
94
95
96
97
98
99
100

MANUAL CHANGE INFORMATION

At Tektronix, we continually strive to keep up with latest electronic developments by adding circuit and component improvements to our instruments as soon as they are developed and tested.

Sometimes, due to printing and shipping requirements, we can't get these changes immediately into printed manuals. Hence, your manual may contain new change information on following pages.

A single change may affect several sections. Since the change information sheets are carried in the manual until all changes are permanently entered, some duplication may occur. If no such change pages appear following this page, your manual is correct as printed.

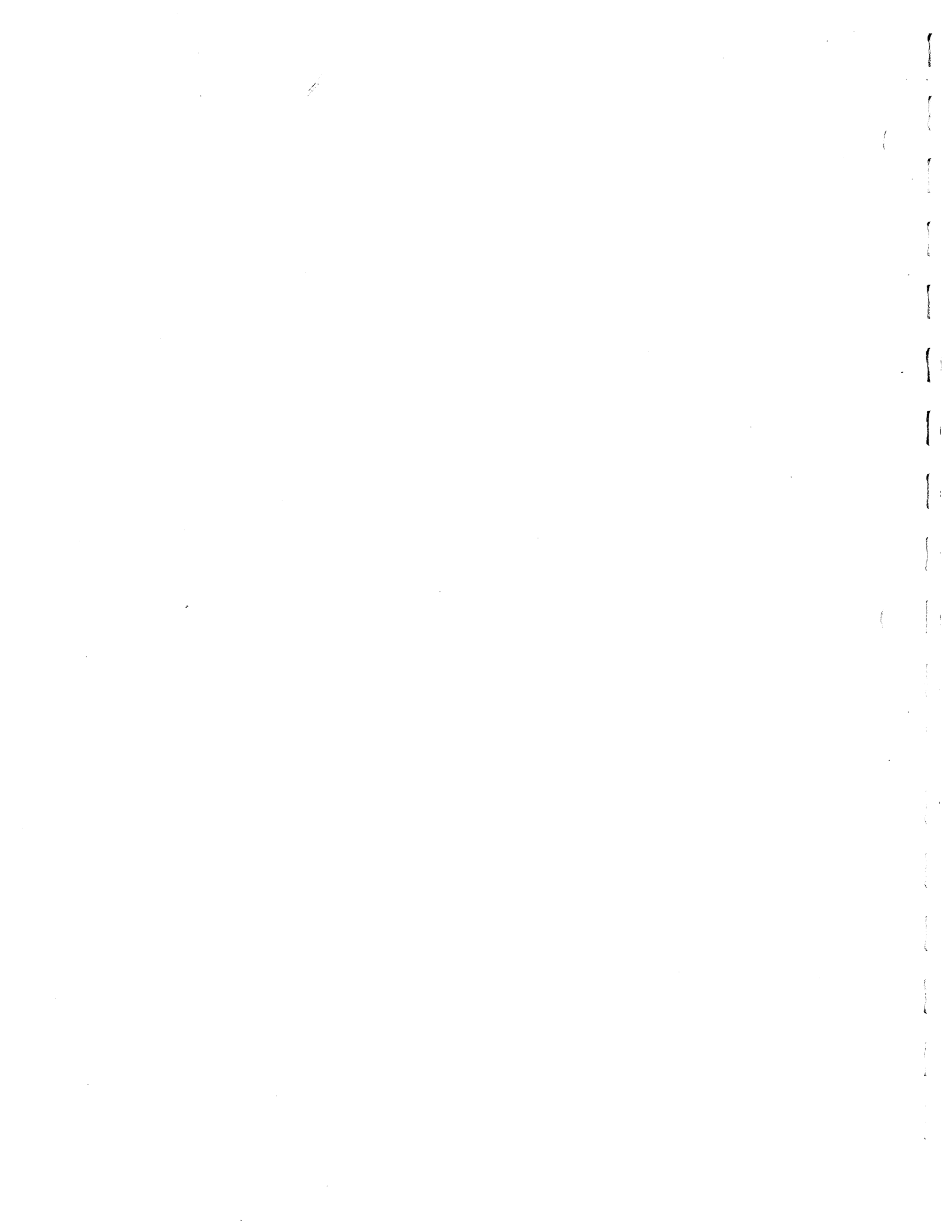

Date: 3-31-82 Change Reference: M38055

Product: 1503 Manual Part No.: 070-1865-01

DESCRIPTION

EFF SN B090000

ELECTRICAL PARTS LIST CHANGE

ADD:

F9100 159-0124-00 FUSE, WIRE LEAD: 3A, 125V, 0.05SEC

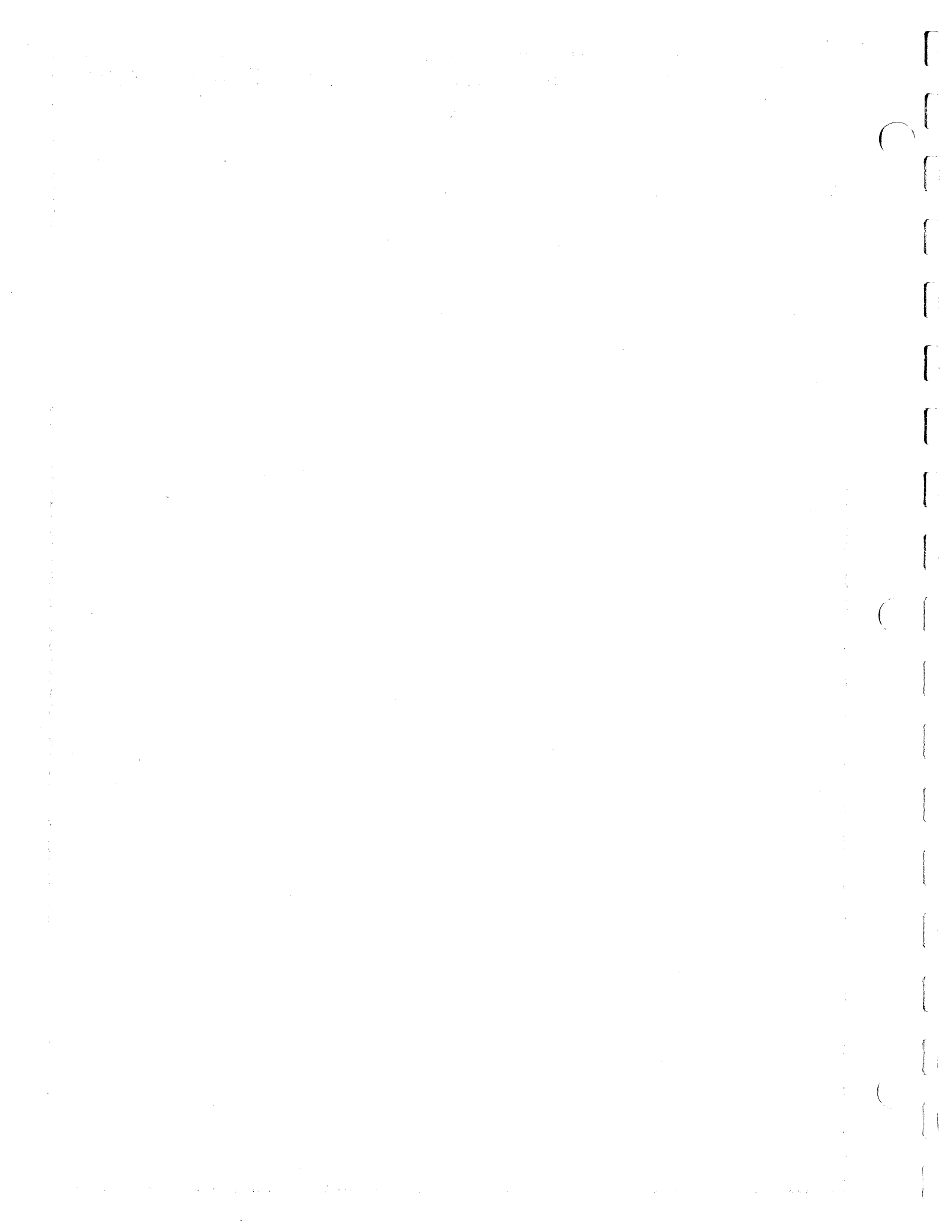

Date: 6-24-82 Change Reference: M44546

Product: see below Manual Part No.: see below

DESCRIPTION

EFF SN B113810 (070-1792-01) 1502

EFF SN B094380 (070-1865-01) 1503

ELECTRICAL PARTS LIST AND SCHEMATIC CHANGES

CHANGE TO:

A3	670-3130-04	CKT BOARD ASSY:OUTPUT AMPLIFIER
R3112	321-0263-00	RES., FXD, FILM:5.36K OHM, 1%, 0.125W
R3114	321-0178-00	RES., FXD, FILM:698 OHM, 1%, 0.125W
R3115	321-0178-00	RES., FXD, FILM:698 OHM, 1%, 0.125W

The above parts are located on the OUTPUT AMPS BD and shown on diagram 
OUTPUT AMPL & HIGH VOLTAGE CIRCUITS

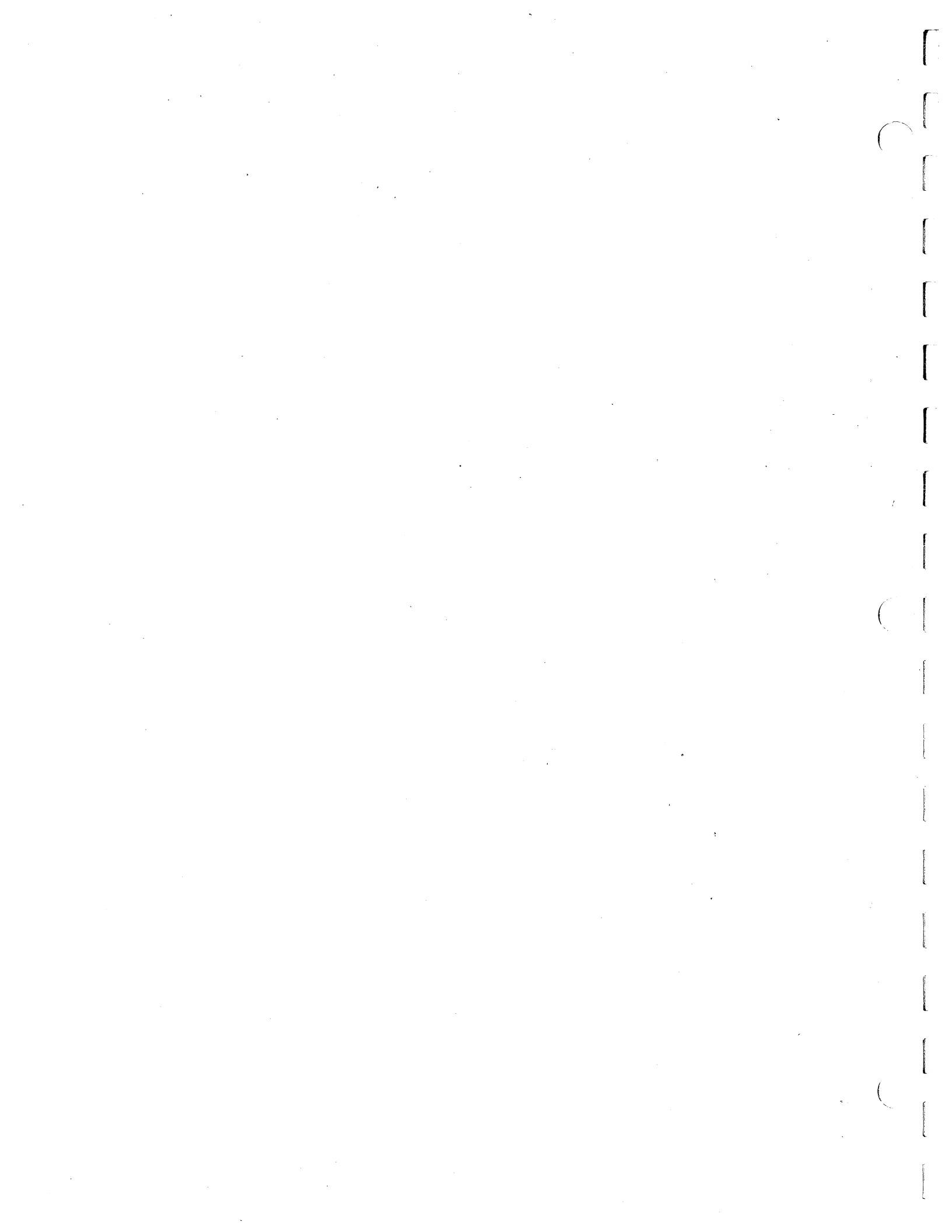

TEKTRONIX MANUALS CHANGE INFORMATION

Date: 6-1-83
Product: see below
Manual Part No.: see below
Change Reference: M46933

DESCRIPTION

EFF SN B114113 (1502) 070-1792-01
EFF SN B094631 (1503) 070-1865-01

ELECTRICAL PARTS LIST AND SCHEMATIC CHANGES

CHANGE TO:

A2	670-3009-03	VERTICAL AMPL/SLOW RAMP ASSY (1502 ONLY)
A2	670-3895-03	VERTICAL AMPL/SLOW RAMP ASSY (1503 ONLY)
C2351*	285-1256-00	CAP., FXD, CER DI: .01UF, 10%, 100V

*Previously not in 1502 manual.

