

Interchangeable Lens Digital Camera

α68

A-mount

Instruction Manual



“Help Guide” (Web manual)

Refer to “Help Guide” for in-depth instructions on the many functions of the camera.

http://rd1.sony.net/help/ilc/1610/h_zz/

English

Learning more about the camera (“Help Guide”)



“Help Guide” is an on-line manual. You can read the “Help Guide” on your computer or smartphone. Refer to it for in-depth instructions on the many functions of the camera.

URL:

http://rd1.sony.net/help/ilc/1610/h_zz/



Owner's Record

Record the model and serial number (which are located on the product) in the space provided below. Refer to these numbers whenever you call your Sony dealer regarding this product.

Model No. ILCA-

Serial No. _____

WARNING

To reduce fire or shock hazard, do not expose the unit to rain or moisture.

IMPORTANT SAFETY INSTRUCTIONS -SAVE THESE INSTRUCTIONS DANGER TO REDUCE THE RISK OF FIRE OR ELECTRIC SHOCK, CAREFULLY FOLLOW THESE INSTRUCTIONS

If the shape of the plug does not fit the power outlet, use an attachment plug adaptor of the proper configuration for the power outlet.



CAUTION

Battery pack

If the battery pack is mishandled, the battery pack can burst, cause a fire or even chemical burns. Observe the following cautions.

- Do not disassemble.
- Do not crush and do not expose the battery pack to any shock or force such as hammering, dropping or stepping on it.
- Do not short circuit and do not allow metal objects to come into contact with the battery terminals.
- Do not expose to high temperature above 60°C (140°F) such as in direct sunlight or in a car parked in the sun.
- Do not incinerate or dispose of in fire.
- Do not handle damaged or leaking lithium ion batteries.
- Be sure to charge the battery pack using a genuine Sony battery charger or a device that can charge the battery pack.
- Keep the battery pack out of the reach of small children.
- Keep the battery pack dry.
- Replace only with the same or equivalent type recommended by Sony.
- Dispose of used battery packs promptly as described in the instructions.

Use a nearby wall outlet (wall socket) when using the supplied or recommended AC Adaptor/battery charger. If any malfunction occurs while using this product, disconnect the plug from the wall outlet (wall socket) immediately to disconnect from the power source.

If you use the product with a charge lamp, note that the product is not disconnected from the power source even when the lamp turns off.

Power Cord

For the customers in the UK, Ireland, Malta, Cyprus and Saudi Arabia
Use the power cord (A). For safety reasons, the power cord (B) is not intended for above countries/regions and shall therefore not be used there.

For the customers in other EU countries/regions

Use the power cord (B).

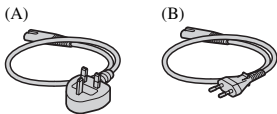

Notice

If static electricity or electromagnetism causes data transfer to discontinue midway (fail), restart the application or disconnect and connect the communication cable (USB, etc.) again.

This product has been tested and found compliant with the limits set out in the EMC regulation for using connection cables shorter than 3 meters (9.8 feet).

The electromagnetic fields at the specific frequencies may influence the picture and sound of this unit.

For Customers in the U.S.A. and Canada

RECYCLING LITHIUM-ION BATTERIES

Lithium-Ion batteries are recyclable.

You can help preserve our environment by returning your used rechargeable batteries to the collection and recycling location nearest you.



For more information regarding recycling of rechargeable batteries, call toll free 1-800-822-8837, or visit <http://www.call2recycle.org/>

Caution: Do not handle damaged or leaking Lithium-Ion batteries.

For supplied accessories

This device complies with Part 15 of the FCC Rules. Operation is subject to the following two conditions:

(1) This device may not cause harmful interference, and (2) this device must accept any interference received, including interference that may cause undesired operation.

CAN ICES-3 B/NMB-3 B

For Customers in the U.S.A.

If you have any questions about this product, you may call:

Sony Customer Information Center
1-800-222-SONY (7669).

The number below is for the FCC related matters only.

Regulatory Information

Declaration of Conformity

Trade Name: SONY

Model No.: ILCA-68

Responsible Party: Sony Electronics Inc.

Address: 16535 Via Esprillo,
San Diego, CA 92127
U.S.A.

Telephone No.: 858-942-2230

This device complies with Part 15 of the FCC Rules. Operation is subject to the following two conditions: (1) This device may not cause harmful interference, and (2) this device must accept any interference received, including interference that may cause undesired operation.

CAUTION

You are cautioned that any changes or modifications not expressly approved in this manual could void your authority to operate this equipment.

Note:

This equipment has been tested and found to comply with the limits for a Class B digital device, pursuant to Part 15 of the FCC Rules.

These limits are designed to provide reasonable protection against harmful interference in a residential installation. This equipment generates, uses, and can radiate radio frequency energy and, if not installed and used in accordance with the instructions, may cause harmful interference to radio communications.

However, there is no guarantee that interference will not occur in a particular installation. If this equipment does cause harmful interference to radio or television reception, which can be determined by turning the equipment off and on, the user is encouraged to try to correct the interference by one or more of the following measures:

- Reorient or relocate the receiving antenna.
- Increase the separation between the equipment and receiver.
- Connect the equipment into an outlet on a circuit different from that to which the receiver is connected.
- Consult the dealer or an experienced radio/TV technician for help.

The supplied interface cable must be used with the equipment in order to comply with the limits for a digital device pursuant to Subpart B of Part 15 of FCC Rules.

For Customers in Europe

Notice for the customers in the countries applying EU Directives

Manufacturer: Sony Corporation, 1-7-1 Konan Minato-ku Tokyo, 108-0075 Japan
For EU product compliance: Sony Belgium, bijkantoor van Sony Europe Limited, Da Vincilaan 7-D1, 1935 Zaventem, Belgium

Disposal of waste batteries and electrical and electronic equipment (applicable in the European Union and other European countries with separate collection systems)

This symbol on the product, the battery or on the packaging indicates that the product and the battery shall not be treated as household waste. On certain batteries this symbol might be used in combination with a chemical symbol. The chemical symbols for mercury (Hg) or lead (Pb) are added if the battery contains more than 0.0005% mercury or 0.004% lead. By ensuring these products and batteries are disposed of correctly, you will help prevent potentially negative consequences for the environment and human health which could otherwise be caused by inappropriate waste handling. The recycling of the materials will help to conserve natural resources.

In case of products that for safety, performance or data integrity reasons require a permanent connection with an incorporated battery, this battery should be replaced by qualified service staff only. To ensure that the battery and the electrical and electronic equipment will be treated properly, hand over these products at end-of-life to the applicable collection point for the recycling of electrical and electronic equipment. For all other batteries, please view the section on how to remove the battery from the product safely. Hand the battery over to the applicable collection point for the recycling of waste batteries. For more detailed information about recycling of this product or battery, please contact your local Civic Office, your household waste disposal service or the shop where you purchased the product or battery.

For Customers in India

Battery Pack

IS 16046/IEC 62133



R-41022780

This manual covers several models supplied with different lenses. The model name varies depending on the supplied lens. The available model varies depending on the countries/regions.

Model name	Lens
ILCA-68	Not supplied
ILCA-68K	Supplied (DT 18-55 mm zoom lens)

Notes on using your camera

Screen language

You can select the language displayed on the screen using the menu.

Shooting procedure

This camera has 2 modes for monitoring subjects: the monitor mode using the monitor, and the viewfinder mode using the viewfinder.

Functions built into this camera

This manual describes 1080 60i-compatible devices and 1080 50i-compatible devices.

Creating an image database file

If you insert a memory card that does not contain an image database file into the camera and turn on the power, the camera automatically creates an image database file using some of the memory card's capacity.

The process may take a long time and you cannot operate the camera until the process is completed. If a database file error occurs, export all images to your computer using PlayMemories Home™, and then format the memory card using the camera.

No compensation for damaged content or recording failure

Sony cannot compensate for failure to record or loss or damage of recorded content due to a malfunction of the camera or recording media, etc.

Back up recommendation

To avoid the data loss, always copy (back up) data to other media.

Notes on the monitor, electronic viewfinder, lens, and image sensor

- The monitor and electronic viewfinder are manufactured using extremely high-precision technology, and over 99.99% of the pixels are operational for effective use. However, there may be some small black dots and/or bright dots (white, red, blue or green in color) that constantly appear on the monitor and electronic viewfinder. These dots are normal due to the manufacturing process and do not affect the images in any way.
- Do not hold the camera by the monitor.
- Do not expose the camera to sunlight or shoot sunward for a long time. The internal mechanism may be damaged. If sunlight is focused on a nearby object, it may cause a fire.
- Do not directly expose the lens to beams such as laser beams. That may damage the image sensor and cause the camera to malfunction.
- Images may trail across on the screen in a cold location. This is not a malfunction. When turning on the camera in a cold location, the screen may become temporarily dark. When the camera warms up, the screen will function normally.
- The recorded image may be different from the image you monitored before recording.

Notes on shooting with the viewfinder

This camera is equipped with an Organic Electro-Luminescence viewfinder with high resolution and high contrast. This viewfinder achieves a wide viewing angle and a long eye relief. This camera is designed to provide an easily viewable viewfinder by appropriately balancing various elements.

- The image may be slightly distorted near the corners of the viewfinder. This is not a malfunction. When you want to see the full composition with all its details, you can also use the monitor.
- If you pan the camera while looking into the viewfinder or move your eyes around, the image in the viewfinder may be distorted or the color of the image may change. This is a characteristic of the lens or display device and is not a malfunction. When you shoot an image, we recommend that you look at the center area of the viewfinder.
- When shooting with the viewfinder, you may experience symptoms such as eyestrain, fatigue, travel sickness, or nausea. We recommend that you take a break at regular intervals when you are shooting with the viewfinder. The required length or frequency of the break may differ depending on the individuals, so you are advised to decide at your own discretion. In case you may feel uncomfortable, refrain from using the viewfinder until your condition recovers, and consult your doctor as necessary.

Notes on recording for long periods of time

- Depending on the camera and battery temperature, you may be unable to record movies or the power may turn off automatically to protect the camera. A message will be displayed on the screen before the power turns off or you can no longer record movies. In this case, leave the power off and wait until the camera and battery temperature goes down. If you turn on the power without letting the camera and battery cool enough, the power may turn off again or you may be unable to record movies.
- Under high ambient temperatures, the temperature of the camera rises quickly.
- When the temperature of the camera rises, the image quality may deteriorate. It is recommended that you wait until the temperature of the camera drops before continuing to shoot.
- The surface of the camera may get warm. This is not a malfunction.

Notes on importing XAVC S movies and AVCHD movies to a computer

When importing XAVC S movies or AVCHD movies to a computer, download and use the software PlayMemories Home from the following website:
<http://www.sony.net/pm/>

Notes on the flash

- Do not carry the camera by the flash unit, or use excessive force on it.
- If water, dust or sand get into the open flash unit, it may cause a malfunction.
- Be sure to keep your fingers out of the way when you press the flash down.

Notes when playing movies on other devices

- Movies recorded with this camera may not be played back correctly on other devices. Also, movies recorded with other devices may not be played back correctly on this camera.
- Discs created from AVCHD movies recorded by this camera can be played back only on AVCHD-compatible devices. DVD players or recorders cannot play back discs created from AVCHD movies, as they are incompatible with the AVCHD format. Also, DVD players or recorders may fail to eject HD discs recorded in AVCHD format.
- Movies recorded in 1080 60p/1080 50p format can be played back only on 1080 60p/1080 50p-supported devices.
- Movies recorded in XAVC S format can be played back only on XAVC S-supported devices.

Warning on copyright

Television programs, films, videotapes, and other materials may be copyrighted. Unauthorized recording of such materials may be contrary to the provisions of the copyright laws.

The pictures used in this manual

The photographs used as examples of pictures in this manual are reproduced images, and are not actual images shot using this camera.

On the data specifications described in this manual

The data on performance and specifications are defined under the following conditions, except as described in this manual: at an ordinary ambient temperature of 25°C (77°F), and using a battery pack that has been fully charged until the CHARGE lamp has turned off.

Checking the supplied items

First check the model name of your camera (page 6). The accessories supplied differ depending on the model.

The number in parentheses indicates the number of pieces.

Supplied with all models:

- Camera (1)
- Battery charger BC-VM10A (1)



- Power cord (mains lead) (1)*
(supplied in some countries/
regions)



* Multiple power cords may be supplied with your camera. Use the appropriate one that matches your country/region. See page 3.

- Rechargeable battery pack NP-FM500H (1)



- Micro USB cable (1)

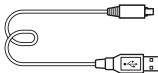

- Shoulder strap (1)

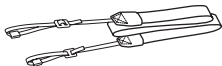

For how to attach the shoulder strap to the camera, refer to page 15.

- Body cap (1) (Attached on the camera)



- Eyepiece Cup (1) (Attached on the camera)
- Instruction Manual (1) (this manual)

ILCA-68K:

- DT 18-55 mm zoom lens (1)/
Front lens cap (1)/Packaging lid
(1)

Identifying parts

See the pages in parentheses for details on operation for the parts.

Front side

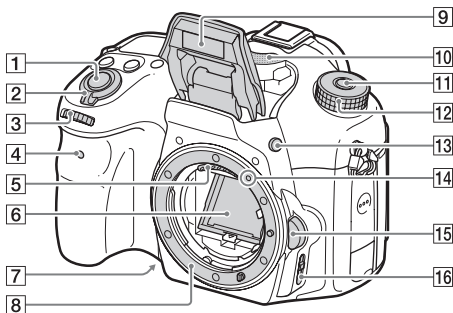

1 Shutter button (30)

2 Power switch (28)

3 Control dial (17)

4 Self-timer lamp

5 Lens contacts*¹

6 Mirror*¹

7 Preview button

8 Mount

9 Built-in flash*¹

- Press the **⚡** (Flash pop-up) button to use the flash.
- When not using the flash, press it back into the camera body.

10 Microphone*²

11 Mode dial lock release button (30, 35)

12 Mode dial (35)

13 **⚡** (Flash pop-up) button

14 Mounting index (26)

15 Lens release button (27)

16 Focus mode switch

*¹ Do not directly touch these parts.

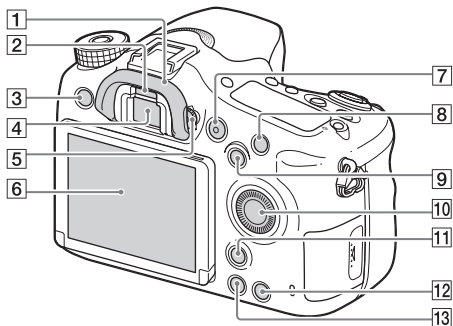

*² Do not cover this part during movie recording. Doing so may cause noise or lower the volume.

Rear side

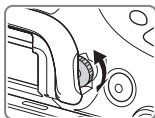

- 1** Eyepiece cup
- 2** Eye sensor
- 3** MENU button (19)
- 4** Viewfinder*
 - When you look into the viewfinder, the viewfinder mode is activated, and when you take your face away from the viewfinder, the screen mode returns to the monitor mode.
- 5** Diopter-adjustment dial
 - Adjust the diopter-adjustment dial according to your eyesight until the display appears clearly in the viewfinder.
- 6** Monitor
- 7** MOVIE button (32)
- 8** For shooting: C1 (Custom 1) button
For viewing: \oplus (Enlarge) button
- 9** For shooting: AEL (AE lock) button/SLOW SYNC button
For viewing: \square (Image index) button
- 10** Control wheel (17)





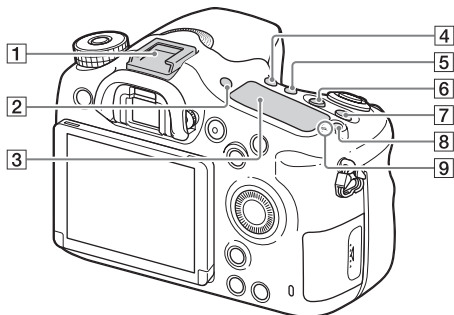

- 11** For shooting: Fn (Function) button (18)
For viewing: , (Image rotation) button
- 12** C2 (Custom 2) button
For viewing: , (Delete) button (34)
- 13**  (Playback) button (33)

* Do not directly touch this part.

Top side



- 1 Multi interface shoe*
- 2 FINDER/MONITOR button
- 3 Display panel
- 4  /  (Drive mode) button
- 5 WB (White balance) button
- 6  (Exposure compensation) button
- 7 ISO button
- 8  (Display panel illumination) button
- 9  Image sensor position mark

* For details on compatible accessories of the Multi interface shoe, visit the Sony website in your area, or consult your Sony dealer or local authorized Sony service facility.

Accessories for the Accessory Shoe can also be used.

Operations with other manufactures' accessories are not guaranteed.

ni Multi Interface Shoe

Accessory Shoe

Sides/Bottom

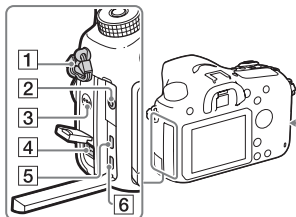
**1** Hooks for shoulder strap

- Attach both ends of the strap onto the camera.

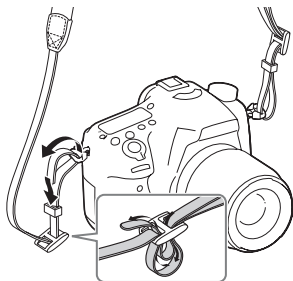
**2** Microphone jack

- When an external microphone is connected, the internal microphone is turned off automatically. When the external microphone is a plug-in-power type, the power of the microphone is supplied by the camera.

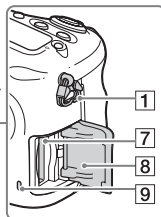
**3** Speaker**4** DC IN terminal

- When connecting the AC-PW10AM AC Adaptor (sold separately) to the camera, turn the camera off, then plug the connector of the AC Adaptor to the DC IN terminal on the camera.

5 HDMI micro jack**6** Multi/Micro USB Terminal*

- Supports Micro USB compatible device.

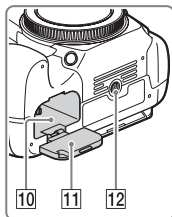
7 Memory card insertion slot (23)**8** Memory card cover (23)**9** Access lamp**10** Battery insertion slot (23)**11** Battery cover (23)

12 Tripod socket hole

- Use a tripod with a screw less than 5.5 mm (7/32 inches) long. Otherwise, you cannot firmly secure the camera, and damage to the camera may occur.

* For details on compatible accessories for the Multi/Micro USB Terminal, visit the Sony website, or consult your Sony dealer or local authorized Sony service facility.

Lens

DT 18-55mm F3.5-5.6 SAM II (Supplied with the ILCA-68K)

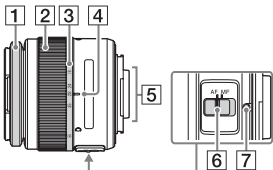

- 1 Focusing ring
- 2 Zoom ring
- 3 Focal-length scale
- 4 Focal-length index
- 5 Lens contacts*
- 6 Focusing mode switch
- 7 Mounting index

* Do not directly touch this part.

- The DT 18-55mm F3.5-5.6 SAM II is designed for Sony A-mount cameras (models equipped with an APS-C sized image sensor). You cannot use these lenses on 35mm-format cameras.
- For the lenses other than DT 18-55mm F3.5-5.6 SAM II, refer to the operating instructions supplied with the lens.

Operating the camera

How to use the control wheel

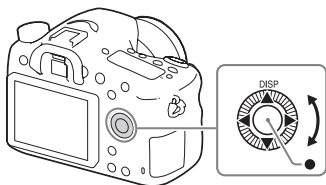

- You can turn the control wheel or press up/down/left/right on the control wheel to move the selection frame. Press ● in the center of the control wheel to set the selected item. In this manual, the action of pressing the up/down/left/right side of the control wheel is indicated by ▲/▼/◀/▶.
- When you turn the control wheel or press ◀/▶ on the control wheel in playback mode, you can display the previous or next image.
- DISP function is assigned to ▲ on the control wheel. You can change the screen display with this function.
- [Standard] is assigned to ● in the center of the control wheel in the default settings. When you press ●, the autofocus function is activated and the camera focuses on the subjects in the central area of the monitor.

How to use the control dial

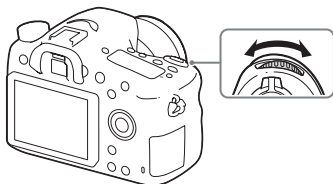

You can turn the control dial to change the settings required for each shooting mode with immediate effect.

Selecting a function using the Fn (Function) button

This button is used for setting up or executing functions used frequently in shooting, except for functions from the Quick Navi screen. The displayed contents and their position shown below are just a guideline, and may differ from the actual display.

1 Press DISP on the control wheel to set the screen mode to other than [For viewfinder].

2 Press the Fn button.

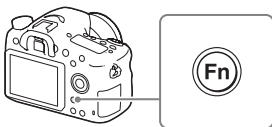

3 Select the desired item using ▲/▼/◀/▶ on the control wheel.

The setting screen appears.

4 Select the desired setting by turning the control wheel, then press ● on the control wheel.

- Some setting values can be finely adjusted by turning the control dial.

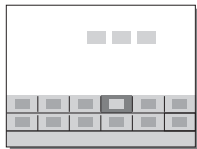

To set the individual settings in the dedicated screen

In step 3, select a setting item and press ● on the control wheel to switch to the dedicated screen for the setting item. Set the items according to the Operation guide.



Operation guide

Functions that can be selected using the MENU button

You can set up the basic settings for the camera as a whole, or execute functions such as shooting, playback, or other operations.

1 Press MENU button to display the menu screen.

2 Select the desired setting item using ▲/▼/◀/▶ on the control wheel or by turning the control wheel, and then press ● on the center of the control wheel.

- Select an icon at the top of the screen and press the ◀/▶ on the control wheel to move to another MENU item.

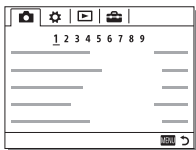

3 Select the setting value, then press ● to confirm.

To display the Tile Menu

Allows you to select whether to always display the first screen of the menu when you press the MENU button.

MENU →  (Setup) → [Tile Menu] → [On]

Using the In-Camera Guide

You can use [Custom Key Settings] to assign In-Camera Guide to the desired button.

The In-Camera Guide displays explanations for the currently selected menu function or setting.

MENU button → ⚙ (Custom Settings) → [Custom Key Settings] → Select the desired button assigned to the function. → [In-Camera Guide]

Press the MENU button and use the control wheel to select a MENU item whose explanation you want to read, and then press the button to which [In-Camera Guide] is assigned.

Charging the battery pack

When using the camera for the first time, be sure to charge the NP-FM500H InfoLITHIUM™ battery pack (supplied).

The InfoLITHIUM battery pack can be charged even when it has not been fully depleted.

It can also be used when it has not been fully charged.

The charged battery pack is discharged little by little, even when you do not use it. To avoid missing an opportunity to shoot, charge the battery pack again before shooting.

1 Insert the battery pack into the battery charger.

Push the battery pack until it clicks.

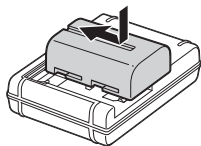

2 Connect the battery charger to the wall outlet (wall socket).

- How to connect the battery charger may differ depending on the country/region.

Light on: Charging

Light off: Charge completed

Charging time (Full charge)	Approx. 175 minutes
-----------------------------	---------------------

- When charging a fully depleted battery pack at a temperature of 25°C (77°F).
- The CHARGE lamp turns off when charging is completed.

With the battery charger that can be connected to the wall outlet (wall socket) directly

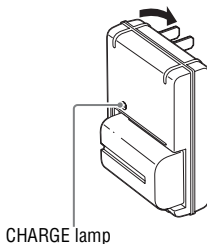

With the battery charger that requires the power cord to connect to the wall outlet (wall socket)

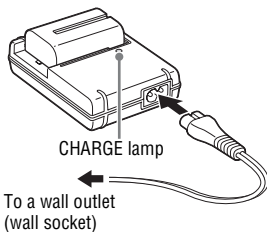

Notes

- The charging time differs depending on the remaining capacity of the battery pack or charging conditions.
- Be sure to use only genuine Sony brand battery packs.
- We recommend charging the battery pack in an ambient temperature of between 10°C to 30°C (50°F to 86°F). You may not be able to efficiently charge the battery pack outside this temperature range.
- Connect the battery charger to the nearest wall outlet (wall socket).

Inserting the battery pack/memory card (sold separately)

- 1 While sliding the battery cover open lever, open the cover.

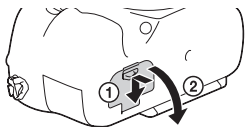

- 2 Firmly insert the battery pack all the way while pressing the lock lever with the tip of the battery.

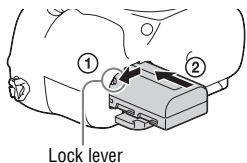

- 3 Close the cover.

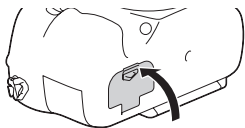

- 4 Slide the memory card cover to open it.



5 Insert a memory card.

- With the notched corner facing as illustrated, insert the memory card until it clicks into place.

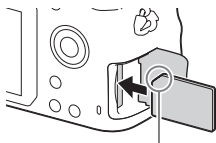

Ensure the notched corner faces correctly

6 Close the cover.

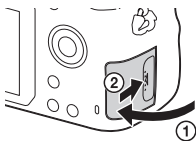

To remove the battery pack

Turn off the camera and slide the lock lever in the direction of the arrow. Be careful not to drop the battery pack.

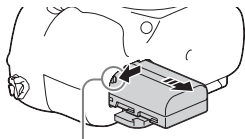

Lock lever

To remove the memory card

Check that the access lamp (page 15) is not lit, then open the cover, and push the memory card once.

To check the remaining battery level

The supplied battery pack is a lithium-ion battery pack that has functions for exchanging information related to operating conditions with your camera. The percentage of the remaining battery life is displayed according to the operating conditions of your camera.

Battery level						“Battery exhausted.”
	High Low					You cannot shoot any more pictures.

Memory cards that can be used

Memory card	For still images	For movies		
		MP4	AVCHD	XAVC S
Memory Stick PRO Duo	✓	✓ (Mark2 only)	✓ (Mark2 only)	—
Memory Stick PRO-HG Duo™	✓	✓	✓	✓
Memory Stick Micro™ (M2)	✓	✓ (Mark2 only)	✓ (Mark2 only)	—
SD memory card	✓	✓ ^{*1}	✓ ^{*1}	—
SDHC memory card	✓	✓ ^{*1}	✓ ^{*1}	✓ ^{*2}
SDXC memory card	✓	✓ ^{*1}	✓ ^{*1}	✓ ^{*2}
microSD memory card	✓	✓ ^{*1}	✓ ^{*1}	—
microSDHC memory card	✓	✓ ^{*1}	✓ ^{*1}	✓ ^{*2}
microSDXC memory card	✓	✓ ^{*1}	✓ ^{*1}	✓ ^{*2}

*1 SD Speed Class 4: **CLASS 4** or faster, or UHS Speed Class 1: **U1** or faster

*2 Memory cards that fulfill all of the following conditions:

- Capacity of 4 GB or more
- SD Speed Class 10: **CLASS 10**, or UHS Speed Class 1: **U1** or faster

- For details on the number of recordable still images and recordable duration of movies, refer to pages 41 to 43. Check the tables to select a memory card with the desired capacity.

Notes

- When an SDHC memory card is used to record XAVC S movies over extended periods of time, the recorded movies will be divided into files of 4 GB. The divided files can be integrated into a single file using PlayMemories Home.
- Not all memory cards are guaranteed to operate correctly. For memory cards produced by manufacturers other than Sony, consult the manufacturers of the products.
- When using Memory Stick Micro media or microSD memory cards with this camera, make sure to use with the appropriate adaptor.

Attaching a lens

Set the power switch of the camera to OFF before you attach or remove the lens.

1 Remove the body cap from the camera and the packaging lid from the rear of the lens.

- When changing the lens, change the lens quickly somewhere away from dusty locations to keep dust or debris from getting inside the camera.
- When shooting, remove the front lens cap from the front of the lens.

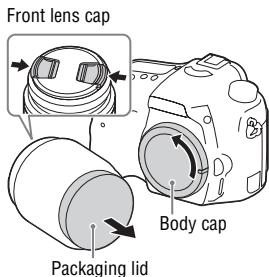

2 Mount the lens by aligning the orange index marks (mounting indexes) on the lens and camera.

- Hold the camera with the lens facing down to prevent dust from entering into the camera.

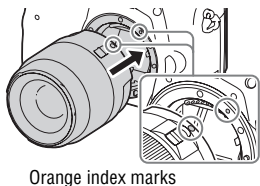

3 While pushing the lens lightly toward the camera, turn the lens clockwise until it clicks into the locked position.

- Be sure to put the lens on straight.

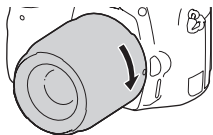

Notes

- When attaching a lens, do not press the lens release button.
- Do not use force when attaching a lens.
- E-mount lenses are not compatible with this camera.
- When you use a lens for which a tripod socket is provided, attach the lens onto the tripod using the tripod socket provided to help balance the weight of the lens.
- When carrying the camera with a lens attached, hold both the camera and the lens firmly.
- Do not hold the part of the lens that is extended for the zoom or focus adjustment.

To remove the lens

- 1 Press the lens release button all the way in and turn the lens counterclockwise until it stops.**

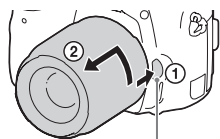

Lens release button

- 2 Attach the caps to the front and rear of the lens and the body cap to the camera.**

- Before you attach them, remove any dust from them.
- A rear lens cap is not supplied with the DT 18-55mm F3.5-5.6 SAM II Lens Kit. If storing the lens without attaching it to the camera, purchase Rear Lens Cap ALC-R55.

Notes on changing the lens

When changing the lens, if dust or debris gets inside the camera and adheres to the surface of the image sensor (the part that converts the light to an electric signal), it may appear as dark spots on the image, depending on the shooting environment.

The camera is equipped with an anti-dust function to prevent dust from landing on the image sensor. However, always make sure to change the lens quickly somewhere away from dusty locations when attaching/removing a lens.

Setting the date and time

When you turn on the camera for the first time or after you initialize the functions, the screen to set the date and time appears.

1 Set the power switch to ON to turn on the camera.

The screen to set the date and time appears.

- To turn the camera off, set the power switch to OFF.

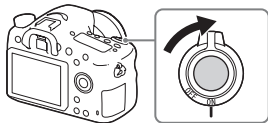

2 Check that [Enter] is selected on the screen, then press ● on the control wheel.

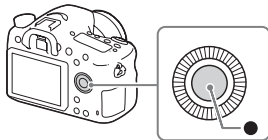

3 Select a desired geographic location, and then press ●.

4 Select a setting item by using ▲/▼ on the control wheel, then press ●.

5 Select a desired setting by using ▲/▼/◀/▶, then press ●.

6 Repeat steps 4 and 5 to set other items, then select [Enter] and press ●.

To cancel the date and time setting operation

Press the MENU button.

Checking or resetting the date/time and area

The date and time setup screen appears automatically when the power is turned on for the first time or when the internal rechargeable backup battery has been discharged. To reset the date and time, use the menu.

MENU button →  (**Setup**) →
[Date/Time Setup] or **[Area Setting]**



MENU button

Maintaining the date and time setting

This camera has an internal rechargeable battery for maintaining the date and time and other settings regardless of whether the power is on or off, or the battery is installed or not.

Shooting still images

In auto mode, the camera analyzes the subject and allows you to shoot with the appropriate settings.

1 Set the power switch to ON to turn on the camera.

2 Set the mode dial to **AUTO** (Auto Mode).

- Turn the mode dial while pressing the mode dial lock release button on the center of the mode dial.



3 Look into the viewfinder and hold the camera.

When using a zoom lens, adjust the zoom ring to the proper size of the subject.

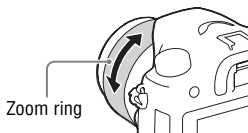

4 Press the shutter button halfway down to focus.

- When the image is in focus, a beep sounds and the ● or (●) indicator lights.

5 Press the shutter button fully down to shoot an image.

- If [Auto Obj. Framing] is set to [Auto], when shooting faces, close-up (macro) subjects, or subjects tracked by [Lock-on AF], the camera analyzes the scene and automatically trims the captured image into a suitable composition. Both the original and the trimmed images will be saved.

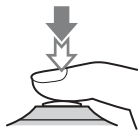

To shoot in dark environments

Use the flash to light up the subject while shooting and to prevent camera-shake.

Press the  (Flash pop-up) button to pop up the flash, then press the shutter button fully down.

You can select an appropriate flash mode to suit your purposes. For details on flash mode, refer to “Help Guide.”

On the number of focus area points

While the camera uses a maximum of 79 focus points for the autofocus functions, the number of focus points will be limited when the following lenses are attached.

Lens	Number of focus points
SAL75300, SAL1118, SAL55200, SAL1855, SAL18552 (Supplied with ILCA-68K), SAL55200-2, SAL30M28, SAL55300	61 points
SAL500F80	One single point at the center

- This information is current as of the day the model was released. Some of the lenses above are not available in some countries or regions.

Recording movies

1 Set the mode dial to (Movie).

- When the [MOVIE Button] is set to [Always], the movie recording can be started from any shooting mode.
-

2 Press the MOVIE button to start recording.

MOVIE button



3 Press the MOVIE button again to stop recording.

Notes

- The sound of the camera in operation may be recorded while recording a movie. You can disable the sound recording by setting [Audio Recording] to [Off].
- The continuous recording time of a movie depends on the ambient temperature or the condition of the camera. See “Notes on continuous movie recording” (page 44).
- When the  icon appears, the temperature of the camera is too high. Turn the camera off and wait until the temperature of the camera decreases.
- When you are recording continuously for a long time, you may feel that the camera is warm. This is normal. Also, “Internal temp. high. Allow it to cool.” may appear. In such cases, turn the camera off and wait until the camera is ready to shoot again.

Playing back images













1 Press the  button.



2 Select an image by pressing the  on the control wheel.

- To play back movies, press  on the control wheel.

If you press  on the control wheel while playing back a movie, the control panel will be displayed.

Control panel	Action during movie playback
	Playback
	Pause
	Fast forward
	Fast rewind
	Forward slow playback
	Rewind slow playback
	Next movie
	Previous movie
	Frame advance
	Frame rewind
	Volume settings
	Closes the control panel

Notes

- Movies recorded using other devices may not play back on this camera.

Deleting images

Once you have deleted an image, you cannot restore it. Be sure that you want to delete the image before proceeding.

1 While displaying the image you want to delete, press the  (Delete) button.



 (Delete) button

2 Select [Delete] with / on the control wheel, then press .

- To delete several images at a time, select MENU button →  (Playback) → [Delete].
-

Notes

- Protected images cannot be deleted.

Selecting a shooting mode

Turn the mode dial while pressing the mode dial lock release button on the center of the mode dial.

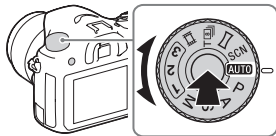

The following shooting modes are available.

AUTO (Auto Mode)	Allows you to shoot still images with the settings adjusted automatically.
P (Program Auto)	Allows you to shoot with the exposure (the shutter speed and the aperture value) adjusted automatically. The other settings can be adjusted manually.
A (Aperture Priority)	Shoots by adjusting the aperture and changing the focus range, or by defocus the background.
S (Shutter Priority)	Adjusts the shutter speed to show the movement of the subject.
M (Manual Exposure)	Allows you to shoot after manually adjusting the exposure (the shutter speed and the aperture value) using the control dial and the control wheel.
1/2/3 (Memory recall)	Calls up settings pre-registered in [Memory] in the (Camera Settings).
 (Movie)	Allows you to change shooting settings and shoot a movie.
 (Tele-zoom Cont. AE)	Allows continuous shooting while the shutter button is fully depressed. The center area of the image is cropped and the camera records the images continuously at a maximum of about 8 images per second. The number of focus area points is set to a maximum of 25 points.
 (Sweep Panorama)	Allows you to shoot panoramic images by combining multiple images.
SCN (Scene Selection)	Allows you to shoot with preset settings according to the scene.

Using the software

Use the following applications to optimize use of the images shot with your camera.

- Image Data Converter
- PlayMemories Home
- Remote Camera Control

For details on installation, see pages 37 to 40.

System requirements

You can find the system requirements for the software at the following URL:

<http://www.sony.net/pcenv/>



Using Image Data Converter

With Image Data Converter, you can do the following:

- You can play back and edit images recorded in RAW format with various corrections, such as tone curve and sharpness.
- You can adjust images with white balance, exposure, and [Creative Style], etc.
- You can save the images displayed and edited on a computer.
You can either save the image as RAW format or save it in a general file format.
- You can display and compare the RAW images and JPEG images recorded by this camera.
- You can rank images in 5 grades.
- You can apply color labels.

To use Image Data Converter, refer to Help.

Click [Start] → [All Programs] → [Image Data Converter] → [Help] → [Image Data Converter Ver.4].

Image Data Converter support page (English only)

<http://www.sony.co.jp/ids-se/>

Installing Image Data Converter

1 Download the software from the following URL and install it on your computer.

Windows:

<http://www.sony.co.jp/imsoft/Win/>

Mac:

<http://www.sony.co.jp/imsoft/Mac/>

Notes

- Log on as Administrator.

Using PlayMemories Home

The software PlayMemories Home allows you to import still images and movies to your computer and use them. PlayMemories Home is required for importing XAVC S movies or AVCHD movies to your computer.



Importing images from your camera

Playing back imported images



For Windows, the following functions are also available:



Viewing images on a calendar



Creating movie discs



Uploading images to network services

Sharing images on PlayMemories Online™



- You can download Image Data Converter or Remote Camera Control, etc. by performing the following procedure:
Connect the camera to your computer → launch PlayMemories Home → click [Notifications].

Notes

- An Internet connection is required to install PlayMemories Home.
- An Internet connection is required to use PlayMemories Online or other network services. PlayMemories Online or other network services may not be available in some countries or regions.
- Refer to the following URL for Mac software:
<http://www.sony.co.jp/imsoft/Mac/>
- If the software PMB (Picture Motion Browser), supplied with models released before 2011, has already been installed on your computer, it will be overwritten by PlayMemories Home during the installation. Use PlayMemories Home, the successor software of PMB.

- Movies recorded using the [60p 28M(PS)]/[50p 28M(PS)], [60i 24M(FX)]/[50i 24M(FX)] or [24p 24M(FX)]/[25p 24M(FX)] setting in [RECORD] Record Setting] are converted by PlayMemories Home to create an AVCHD recording disc. This conversion can take a long time. Also, you cannot create a disc with the original image quality. If you want to keep the original image quality, store your movies on a Blu-ray Disc.

Installing PlayMemories Home

- 1 Using the Internet browser on your computer, go to the following URL, then click [Install] → [Run].**

<http://www.sony.net/pm/>

- 2 Follow the instructions on the screen to complete the installation.**

Using Remote Camera Control

Connect the camera to your computer. With Remote Camera Control you can:

- Set up the camera or record an image from the computer.
- Record an image directly to the computer.
- Perform an Interval Timer Shooting.

Set up the following before use: MENU →  (Setup) → [USB Connection] → [PC Remote]

Installing Remote Camera Control

1 Using the Internet browser on your computer, go to the following URL.

Windows:

<http://www.sony.co.jp/imsoft/Win/>

Mac:

<http://www.sony.co.jp/imsoft/Mac/>

2 Follow the instructions on the screen to download and install Remote Camera Control.

Notes

- An Internet connection is required to install Remote Camera Control.

Checking the number of images and recordable time of movies

When you insert a memory card into the camera and set the power switch to ON, the number of images that can be recorded (should you continue to shoot using the current settings) is displayed on the screen.

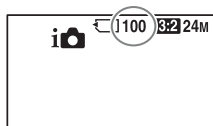

Notes

- When “0” (the number of recordable images) flashes in yellow, the memory card is full. Replace the memory card with another one, or delete images from the current memory card (page 34).
- When “NO CARD” (the number of recordable images) flashes in yellow, it means no memory card has been inserted. Insert a memory card.

The number of images that can be recorded on a memory card

The table below shows the approximate number of images that can be recorded on a memory card formatted with this camera. The values are defined using Sony standard memory cards for testing. The values may vary depending on the shooting conditions and the type of memory card used.

Image Size: L: 24M

Aspect Ratio: 3:2*

Memory card formatted with this camera (Units: Images)

Capacity \ Quality	2 GB	4 GB	8 GB	16 GB	32 GB	64 GB
Standard	330	660	1300	2700	5400	10500
Fine	200	405	820	1650	3300	6600
Extra fine	100	200	405	810	1600	3250
RAW & JPEG	53	105	215	435	880	1750
RAW	73	145	295	600	1200	2400

* When [Aspect Ratio] is set to [16:9], you can record more images than the numbers shown in the table above (except when [RAW] is selected).

The number of images that can be recorded using a battery pack

Note that the actual numbers may differ depending on the conditions of use.

		Battery life	Number of images
Shooting (still images)	Monitor	—	Approx. 580 images
	Viewfinder	—	Approx. 540 images
Actual shooting (movies)	Monitor	Approx. 130 min.	—
	Viewfinder	Approx. 130 min.	—
Continuous shooting (movies)	Monitor	Approx. 220 min.	—
	Viewfinder	Approx. 220 min.	—
Viewing (still images)	Monitor	Approx. 410 min.	Approx. 8200 images
	Viewfinder	Approx. 410 min.	Approx. 8200 images

Notes

- The above number of images applies when the battery pack is fully charged. The number of images may decrease depending on the conditions of use.
- The number of images that can be recorded is for shooting under the following conditions:
 - The battery pack is used at an ambient temperature of 25°C (77°F).
 - Using the lens DT 18-55mm F3.5-5.6 SAM II
 - Using Sony Memory Stick PRO Duo (Mark2) media (sold separately)
 - [Viewfinder Bright.] is set to [Manual] [±0].
 - [Monitor Brightness] is set to [Manual] [±0].
- The number for “Shooting (still images)” is based on the CIPA standard, and is for shooting under the following conditions: (CIPA: Camera & Imaging Products Association)
 - DISP is set to [Display All Info.].
 - [Focus Mode] is set to [AF-S].
 - Shooting once every 30 seconds.
 - The flash is used once every two times.
 - The power turns on and off once every ten times.

- The number of minutes for movie shooting is based on the CIPA standard, and are for shooting under the following conditions:
 - [RECORD] Record Setting] is set to [30p 50M]/[25p 50M].
 - Typical movie shooting: Battery life based on repeatedly shooting, zooming, shooting stand-by, turning on/off, etc.
 - Continuous movie shooting: Battery life based on non-stop shooting until the limit (29 minutes) has been reached, and then continued by pressing the MOVIE button again. Other functions, such as zooming, are not operated.

Available recording time for a movie

The table below shows the approximate total recording times using a memory card formatted with this camera.

Memory card formatted with this camera

File Format	Record Setting	Recordable time (h (hour), m (minute))		
		8 GB	32 GB	64 GB
XAVC S	60p 50M/ 50p 50M	15 m	1 h 15 m	2 h 35 m
	30p 50M/ 25p 50M	15 m	1 h 15 m	2 h 35 m
	24p 50M*/–	15 m	1 h 15 m	2 h 35 m
AVCHD	60p 28M(PS)/ 50p 28M(PS)	35 m	2 h 30 m	5 h 5 m
	60i 24M(FX)/ 50i 24M(FX)	40 m	3 h	6 h
	60i 17M(FH)/ 50i 17M(FH)	1 h	4 h 5 m	8 h 15 m
	24p 24M(FX)/ 25p 24M(FX)	40 m	3 h	6 h
	24p 17M(FH)/ 25p 17M(FH)	1 h	4 h 5 m	8 h 15 m
MP4	1440×1080 12M	1 h 20 m	5 h 30 m	11 h 5 m
	VGA 3M	4 h 55 m	20 h	40 h 10 m

* Only when [PAL/NTSC Selector] is set to NTSC

- Continuous shooting is possible for approximately 29 minutes (a product specification limit).

Notes

- The recordable time of movies varies because the camera is equipped with VBR (Variable Bit-Rate), which automatically adjusts image quality depending on the shooting scene. When you record a fast-moving subject, the image is clearer but the recordable time is shorter because more memory is required for recording. The recordable time also varies depending on the shooting conditions, the subject or the image quality/size settings.
- The values shown are not for continuous recording time.
- The recording time may differ depending on shooting conditions and the memory card used.
- For details on movie playback, see page 33.

Notes on continuous movie recording

- It requires a lot of power to perform high quality movie recording or continuous shooting using the image sensor. Therefore, if you continue to shoot, the temperature inside the camera will rise, especially that of the image sensor. In such cases, the camera turns off automatically since higher temperatures affect the quality of the images or affect the internal mechanism of the camera.
- The duration of time available for movie recording is as follows when the camera starts recording after the power of the camera has been turned off for a while. (The following values indicate the continuous time from when the camera starts recording until the camera stops recording.)

Ambient temperature	Continuous recording time for movies
20°C (68°F)	About 29 minutes
30°C (86°F)	About 29 minutes
40°C (104°F)	About 25 minutes

- The duration of time available for movie recording varies with the temperature or condition of the camera before you start recording. If you frequently recompose or shoot images after the power is turned on, the temperature inside the camera will rise and the recording time available will be shorter.
- When  is indicated, stop recording the movie. The temperature inside the camera has increased to an unacceptable level.
- If the camera stops recording due to the temperature, leave it for several minutes with the power turned off. Start recording after the temperature inside the camera drops fully.

- If you observe the following points, the recording time will be longer.
 - Keep the camera out of direct sunlight.
 - Turn the camera off when it is not being used.
- The maximum size of a movie file is about 2 GB, when [ File Format] is set to [AVCHD]. When the file size is about 2 GB, a new movie file is created automatically.
- The maximum continuous recording time is 29 minutes.

Specifications

Camera

[System]

Camera Type: Built-In-Flash
Interchangeable Lens Digital
Camera

Lens: Sony A-mount lens

[Image sensor]

Image format: 23.5 mm × 15.6 mm
(APS-C format) CMOS image
sensor

Effective pixel number of camera:

Approx. 24 160 000 pixels

Total pixel number of image sensor:

Approx. 24 780 000 pixels

[SteadyShot]

For still images:

System: Image sensor-shift
mechanism

For movies:

System: Electronic

[Anti-Dust]

System: Anti-dust coating on image
sensor and image sensor shift
mechanism

[Auto focus system]

System: TTL phase-detection system
(with center F2.8 sensor),

79 points (15 points cross type)

Sensitivity Range: -2 EV to 18 EV
(at ISO 100 equivalent)

AF illuminator: Approx. 1 m to 5 m
(3.3 ft. to 16.4 ft.)

[Electronic viewfinder]

Type: Electronic viewfinder (Organic
Electro-Luminescence)

Screen size: 1.0 cm (0.39 type)

Total number of dots: 1 440 000 dots

Frame coverage: 100%

Magnification:

Approx. 0.88 ×

Approx. 0.57 × (35mm-format
equivalent) with 50 mm lens at
infinity, -1 m⁻¹

Eye Point: Approximately 26.5 mm

from the eyepiece and
approximately 23 mm from the
eyepiece frame at -1 m⁻¹ (CIPA
standard compliant)

Diopter Adjustment: -4.0 m⁻¹ to
+3.0 m⁻¹

[Monitor]

LCD monitor: 6.7 cm (2.7 type) TFT
drive/Clear Photo LCD screen

Total number of dots: 460 800 dots

[Exposure control]

Metering Cell: "Exmor" CMOS sensor

Metering method: 1 200-zone evaluative metering

Metering Range: -2 EV to +17 EV on Multi segment, Center weighted, Spot modes (at ISO 100 equivalent with F1.4 lens)

ISO sensitivity (Recommended exposure index):

Still images: AUTO, ISO 100 to 25 600 (1/3 EV step)

Movies: AUTO, ISO 100 to 12 800 (1/3 EV step)

Exposure compensation: ± 5.0 EV (switchable between 1/3 EV and 1/2 EV steps)

[Shutter]

Type: Electronically-controlled, vertical-traverse, focal-plane type

Speed range:

Still images: 1/4 000 second to 30 seconds, BULB

Movies: 1/4 000 second to 1/4 second (1/3 EV step)

- 1080 60i-compatible device up to 1/60 second in AUTO mode (up to 1/30 second in Auto slow shutter mode)

- 1080 50i-compatible device up to 1/50 second in AUTO mode (up to 1/25 second in Auto slow shutter mode)

Flash sync speed: 1/160 second

[Built-In-Flash]

Flash G.No.: GN 12 (in meters at ISO 100)

Recycling time: Approx. 3 seconds

Flash coverage: Covering 16 mm lens (focal length that the lens indicates)

Flash compensation: ± 3.0 EV (switchable between 1/3 EV and 1/2 EV steps)

Flash range:

Aperture		F2.8	F4.0	F5.6
ISO setting	100	1 m – 4.3 m (3.3 ft. – 14.1 ft.)	1 m – 3 m (3.3 ft. – 9.8 ft.)	1 m – 2.1 m (3.3 ft. – 7.0 ft.)
	200	1 m – 6.1 m (3.3 ft. – 19.9 ft.)	1 m – 4.2 m (3.3 ft. – 13.9 ft.)	1 m – 3 m (3.3 ft. – 9.9 ft.)
	400	1.4 m – 8.6 m (4.7 ft. – 28.1 ft.)	1 m – 6 m (3.3 ft. – 19.7 ft.)	1 m – 4.3 m (3.3 ft. – 14.1 ft.)
	800	2 m – 12 m (6.6 ft. – 39.8 ft.)	1.4 m – 8.5 m (4.6 ft. – 27.8 ft.)	1 m – 6.1 m (3.3 ft. – 19.9 ft.)

Others

[Continuous shooting]

Continuous shooting speed:

[Tele-zoom Cont. AE]:

Maximum 8 images per second/

 Hi : Maximum 5 images per

second/  Lo : Maximum

2.5 images per second

- Based on our measurement conditions. The speed of continuous shooting can be slower, depending on the shooting conditions.

The maximum number of continuous shots:

In [Tele-zoom Cont. AE] mode

Extra fine: 34 images/

Fine: 63 images/

Standard: 112 images/

In Continuous shooting

Extra fine: 21 images/

Fine: 32 images/

Standard: 35 images/

RAW & JPEG: 8 images/

RAW: 8 images

[Image zooming playback]

Scaling range:

Image size:

L: Approx. $\times 1.0 - \times 18.75$ /

M: Approx. $\times 1.0 - \times 13.25$ /

S: Approx. $\times 1.0 - \times 9.4$

[Recording format]

File format: JPEG (DCF Ver. 2.0,

Exif Ver. 2.3, MPF Baseline)

compliant, RAW (Sony ARW 2.3 format)

Movie (XAVC S format): MPEG-4

AVC/H.264 XAVC S ver.1.0

format compliant

Video: MPEG-4 AVC/H.264

Audio: LPCM 2ch (48 kHz

16 bit)

Movie (AVCHD format): AVCHD

format Ver. 2.0 compatible

Video: MPEG-4 AVC/H.264

Audio: Dolby Digital 2ch, equipped with Dolby Digital Stereo Creator

- Manufactured under license from Dolby Laboratories.

Movie (MP4 format):

Video: MPEG-4 AVC/H.264

Audio: MPEG-4 AAC-LC 2ch

[Recording media]

Memory Stick PRO Duo media, SD card

[Input/output terminals]

Multi/Micro USB Terminal*:

USB communication, Hi-Speed USB (USB 2.0)

* Supports Micro USB compatible devices.

HDMI: HDMI type D micro jack

Mic Terminal: \varnothing 3.5 mm Stereo mini jack

[Power, general]

Battery pack: Rechargeable battery pack NP-FM500H

[Power consumption (while shooting)]

When using a DT 18-55mm F3.5-5.6 SAM II*

When using the viewfinder:

Approx. 2.7 W

When using the screen:

Approx. 2.5 W

* Supplied with ILCA-68K.

[Others]

Microphone: Stereo

Speaker: Monaural

Exif Print: Compatible

DPOF: Compatible

PRINT Image Matching III:

Compatible

Dimensions (Approx.):

142.6 mm × 104.2 mm ×

82.8 mm (5 5/8 inches ×

4 1/8 inches × 3 3/8 inches)

(W/H/D, excluding protrusions)

Mass:

Approx. 675 g (1 lb 7.8 oz) (with battery and Memory Stick PRO Duo media)

Approx. 596 g (1 lb 5 oz) (body only)

Operating temperature: 0°C to 40°C

(32°F to 104°F)

Storage temperature:

-20°C to +60°C (-4°F to +140°F)

Design and specifications are subject to change without notice.

Battery charger/Battery**Battery charger BC-VM10A**

Input rating: AC 100 V – 240 V, 50 Hz/60 Hz, 9 W

Output rating: DC 8.4 V, 0.75 A

Rechargeable battery pack NP-FM500H

Battery type: Lithium-ion battery

Maximum voltage: DC 8.4 V

Nominal voltage: DC 7.2 V

Maximum charge voltage: DC 8.4 V

Maximum charge current: 2.0 A

Capacity: 11.5 Wh (1 600 mAh)

Lens DT 18-55mm F3.5-5.6 SAM II (Supplied with ILCA-68K)

Focal length: Equivalent 35 mm-format focal length*¹:

27 mm – 82.5 mm

Lens groups/elements: 7/8

Angle of view*¹: 76° – 29°

Minimum focus*²: 0.25 m (0.82 ft.)

Maximum magnification: 0.34

Minimum f-stop: f/22 – f/36

Filter diameter: 55 mm

Dimensions (max. diameter × height): Approx. 71.6 mm × 69 mm (Approx. 2 7/8 inches × 2 3/4 inches)

Mass: Approx. 222 g (Approx. 7 7/8 oz.)

- *¹ The values for equivalent 35mm-format focal length and angle of view are based on Interchangeable Lens Digital Camera equipped with an APS-C sized image sensor.
- *² Minimum focus is the shortest distance from the image sensor to the subject.
- This lens is equipped with a distance encoder. The distance encoder allows more accurate measurement (ADI) by using a flash with ADI functionality.
- Depending on the lens mechanism, the focal length may change with any change of the shooting distance. The focal length assumes the lens is focused at infinity.

- The infinity position provides for some adjustment to compensate for focus shift caused by change in temperature. To shoot a subject at infinite distance in MF mode, use the viewfinder and set focus.



On focal length

The picture angle of this camera is narrower than that of a 35 mm-format camera. You can find the approximate equivalent of the focal length of a 35 mm-format camera, and shoot with the same picture angle, by increasing the focal length of your lens by half. For example, by using a 50 mm lens, you can get the approximate equivalent of a 75 mm lens of a 35 mm-format camera.

On image data compatibility

- This camera conforms with DCF (Design rule for Camera File system) universal standard established by JEITA (Japan Electronics and Information Technology Industries Association).
- Playback of images recorded with your camera on other equipment and playback of images recorded or edited with other equipment on your camera are not guaranteed.

Trademarks

- Memory Stick and  are trademarks or registered trademarks of Sony Corporation.
- XAVC S and  are registered trademarks of Sony Corporation.
- “AVCHD Progressive” and the “AVCHD Progressive” logotype are trademarks of Panasonic Corporation and Sony Corporation.
- Dolby and the double-D symbol are trademarks of Dolby Laboratories.
- The terms HDMI and HDMI High-Definition Multimedia Interface, and the HDMI Logo are trademarks or registered trademarks of HDMI Licensing LLC in the United States and other countries.
- Windows is a registered trademark of Microsoft Corporation in the United States and/or other countries.
- Mac is a registered trademark of Apple Inc. in the United States and other countries.
- SDXC logo is a trademark of SD-3C, LLC.
- Facebook and the “f” logo are trademarks or registered trademarks of Facebook, Inc.
- YouTube and the YouTube logo are trademarks or registered trademarks of Google Inc.
- Eye-Fi is a trademark of Eye-Fi, Inc.
- In addition, system and product names used in this manual are, in general, trademarks or registered trademarks of their respective developers or manufacturers. However, the TM or ® marks may not be used in all cases in this manual.



Index

A

- Area Setting28
- AUTO30
- Auto Mode30

B

- Battery pack21, 23

C

- CHARGE lamp22
- Charging battery pack21
- Computer36
- Control wheel17

D

- Date/Time Setup28
- DC IN terminal15
- Delete34
- Diopter-adjustment12

E

- Eye sensor12

F

- Flash31
- Fn18
- Focal length50
- Function button18

H

- Help Guide 2

I

- Image Data Converter 37
- In-Camera Guide 20

L

- Language 7
- Lens 26

M

- Memory card 23, 25
- MENU 19
- MOVIE 32
- MOVIE Button 32
- MR 35
- Multi interface shoe 14

N

- Number of recordable images 41

P

- PlayMemories Home 38, 39

R

- Recordable time of movies 43
- Recording movies 32
- Remote Camera Control 39

S

Set the clock	28
Shooting	30
Shooting mode	35
Shooting still images	30
Shoulder strap	15
Software	36
Specifications	46

V

Viewfinder	12
Viewing image	33



<http://www.sony.net/SonyInfo/Support/>

Additional information on this product and answers to frequently asked questions can be found at our Customer Support Website.

<http://www.sony.net/>



4590091120