

- ▶ Before Use
- ▶ Shooting
- ▶ Viewing
- ▶ Using MENU items (Shooting)
- ▶ Using MENU items (Viewing)
- ▶ Changing settings
- ▶ Viewing images on a TV
- ▶ Using with your computer
- ▶ Printing
- ▶ Troubleshooting
- ▶ Precautions / About this camera

[→ Contents list](#)

DSC-H90 User Guide

Use this manual if you encounter any problems, or have any questions about the camera.



Cyber-shot

[▲ Back to top](#)

Table of Contents

Before Use.....	1
How to use this User Guide.....	17
Selecting a topic to display.....	17
Searching a topic by keyword.....	18
Returning to a previous page.....	18
Printing out a page.....	18
Marks and notations used in this User Guide.....	18
Names of parts.....	20
List of icons displayed on the screen.....	22
List of shooting mode icons.....	22
List of viewing mode icons.....	24
Using the wrist strap.....	26
Using the internal memory.....	27
On image data stored in the internal memory.....	27
In-Camera Guide.....	29
Shooting.....	2
Shooting still images.....	30
Zoom.....	32
Shooting movies.....	33
Setting REC mode.....	2
List of mode dial functions.....	34
Intelligent Auto.....	35
Program Auto.....	36
Manual Exposure Shooting.....	37
Scene Selection.....	39
Sweep Panorama.....	42
Movie Mode.....	45
Functions not available in some REC modes.....	46
Functions available in REC modes.....	46
Functions available in Scene Selection.....	46
Functions available in Picture Effect.....	47
Using shooting functions.....	2
Tracking focus.....	48
DISP (Display Setting).....	49
Histogram.....	49
Flash.....	51
Smile Shutter.....	53
Self-Timer.....	55

Automatic shooting with Self-portrait timer.....	55
Viewing.....	3
Viewing still images.....	57
Playback zoom.....	58
Image Index.....	59
Delete button.....	61
Viewing movies.....	62
Scrolling the panorama images for display.....	63
Using MENU items (Shooting).....	4
Using MENU items (Shooting).....	64
MENU items (Shooting).....	4
Scene Selection.....	65
Easy Mode.....	68
On Scene Recognition.....	68
Shooting functions available in Easy Mode (Shooting).....	68
Still Image Size / Panorama Image Size / Movie Size.....	70
Image size when shooting still images.....	70
Image size in Easy Mode.....	70
Image size when shooting Sweep Panorama.....	71
Image size when shooting movies.....	71
Cont. Shooting Settings.....	72
Bracket Setting.....	73
EV.....	74
ISO.....	75
White Balance.....	76
Focus.....	78
Metering Mode.....	80
Scene Recognition.....	81
Soft Skin Effect.....	83
Smile Detection Sensitivity.....	84
Face Detection.....	85
DRO.....	86
Anti Blink.....	87
Movie SteadyShot.....	88
Picture Effect.....	89
Color hue.....	91
Extracted Color.....	92
In-Camera Guide.....	93
MENU items not available in some REC modes.....	94
Using MENU items (Viewing).....	5

Using MENU items (Viewing).....	96
MENU items (Viewing).....	5
Slideshow.....	97
View Mode.....	100
Retouch.....	101
Delete.....	103
Protect.....	104
Print (DPOF).....	105
Rotate.....	106
In-Camera Guide.....	107
MENU items that cannot be set according to View Mode.....	108
Changing settings.....	6
Changing camera settings.....	109
Shooting Settings.....	6
AF Illuminator.....	110
Grid Line.....	111
Disp. Resolution.....	112
Digital Zoom.....	113
Red Eye Reduction.....	114
Blink Alert.....	115
Write Date.....	116
Main Settings.....	6
Beep.....	117
Panel Brightness.....	118
Language Setting.....	119
Display color.....	120
Demo Mode.....	121
Initialize.....	122
Function Guide.....	123
Video Out.....	124
Eco Mode.....	125
USB Connect Setting.....	126
LUN Setting.....	127
Download Mu.....	128
Empty Music.....	129
Eye-Fi.....	130
Memory Card Tool/Internal Memory Tool.....	6
Format.....	132
Create REC.Folder.....	133
Change REC.Folder.....	134

Delete REC.Folder.....	135
Copy.....	136
File Number.....	137
Clock Settings.....	6
Area Setting.....	138
Date & Time Setting.....	139
Viewing images on a TV.....	7
Viewing an image on a Standard Definition (SD) TV.....	140
Using with your computer.....	8
Recommended computer environment.....	141
Using the software.....	8
“PlayMemories Home” (Windows)	142
Installing “PlayMemories Home” (Windows)	143
“Music Transfer”	145
Software for Mac.....	146
Importing images to a computer.....	8
Connecting the camera to the computer.....	147
Importing images to a computer.....	148
Deleting the USB connection.....	149
Printing.....	9
Printing still images.....	150
Troubleshooting.....	10
If you have problems.....	151
Battery pack and power.....	152
Shooting still images/movies.....	154
Viewing images.....	157
Computers.....	158
Memory card.....	159
Internal memory.....	160
Printing.....	161
Others.....	162
Warning indicators and messages.....	10
Self-diagnosis display.....	163
Messages.....	164
Situations this camera has difficulty handling.....	168
Precautions / About this camera.....	11
Precautions.....	169
On the internal rechargeable backup battery.....	171
Battery pack.....	172
Battery charger.....	174

Memory card.....	175
On cleaning.....	178
Number of still images.....	179
Recordable time of movies.....	180
Using the camera abroad.....	181
On TV color systems.....	182
License.....	183
Trademarks.....	184

[▶ Before Use](#)[▶ Shooting](#)[▶ Viewing](#)[▶ Using MENU items \(Shooting\)](#)[▶ Using MENU items \(Viewing\)](#)[▶ Changing settings](#)[▶ Viewing images on a TV](#)[▶ Using with your computer](#)[▶ Printing](#)[▶ Troubleshooting](#)[▶ Precautions / About this camera](#)[→ Contents list](#)

Before Use

How to use this User Guide

[How to use this User Guide](#)

Names of parts and list of icons displayed on the screen

[Names of parts](#)

[List of icons displayed on the screen](#)

Using the wrist strap

[Using the wrist strap](#)

Using the internal memory

[Using the internal memory](#)

In-Camera Guide

[In-Camera Guide](#)

[▲ Back to top](#)

- ▶ Before Use
- ▶ Shooting
- ▶ Viewing
- ▶ Using MENU items (Shooting)
- ▶ Using MENU items (Viewing)
- ▶ Changing settings
- ▶ Viewing images on a TV
- ▶ Using with your computer
- ▶ Printing
- ▶ Troubleshooting
- ▶ Precautions / About this camera

[→ Contents list](#)

Shooting

Shooting still images

[Shooting still images](#)

[Zoom](#)

Shooting movies

[Shooting movies](#)

Setting REC mode

[List of mode dial functions](#)

[Intelligent Auto](#)

[Program Auto](#)

[Manual Exposure Shooting](#)

[Scene Selection](#)

[Sweep Panorama](#)

[Movie Mode](#)

[Functions not available in some REC modes](#)

Using shooting functions

[Tracking focus](#)

[DISP \(Display Setting\)](#)

[Flash](#)

[Smile Shutter](#)

[Self-Timer](#)

[▲ Back to top](#)

- ▶ [Before Use](#)
- ▶ [Shooting](#)
- ▶ [Viewing](#)
- ▶ [Using MENU items \(Shooting\)](#)
- ▶ [Using MENU items \(Viewing\)](#)
- ▶ [Changing settings](#)
- ▶ [Viewing images on a TV](#)
- ▶ [Using with your computer](#)
- ▶ [Printing](#)
- ▶ [Troubleshooting](#)
- ▶ [Precautions / About this camera](#)

[→ Contents list](#)

Viewing

Viewing still images

[Viewing still images](#)

[Playback zoom](#)

[Image Index](#)

Deleting images

[Delete button](#)

Viewing movies

[Viewing movies](#)

Viewing panorama images

[Scrolling the panorama images for display](#)

[▲ Back to top](#)

- ▶ Before Use
- ▶ Shooting
- ▶ Viewing
- ▶ **Using MENU items (Shooting)**
- ▶ Using MENU items (Viewing)
- ▶ Changing settings
- ▶ Viewing images on a TV
- ▶ Using with your computer
- ▶ Printing
- ▶ Troubleshooting
- ▶ Precautions / About this camera

[➔ Contents list](#)

Using MENU items (Shooting)

Using MENU items (Shooting)

[Using MENU items \(Shooting\)](#)

MENU items (Shooting)

[Scene Selection](#)

[Easy Mode](#)

[Still Image Size / Panorama Image Size / Movie Size](#)

[Cont. Shooting Settings](#)

[Bracket Setting](#)

[EV](#)

[ISO](#)

[White Balance](#)

[Focus](#)

[Metering Mode](#)

[Scene Recognition](#)

[Soft Skin Effect](#)

[Smile Detection Sensitivity](#)

[Face Detection](#)

[DRO](#)

[Anti Blink](#)

[Movie SteadyShot](#)

[Picture Effect](#)

[Color hue](#)

[Extracted Color](#)

[In-Camera Guide](#)

Shooting MENU list

[MENU items not available in some REC modes](#)

[▲ Back to top](#)

- ▶ Before Use
- ▶ Shooting
- ▶ Viewing
- ▶ Using MENU items (Shooting)
- ▶ **Using MENU items (Viewing)**
- ▶ Changing settings
- ▶ Viewing images on a TV
- ▶ Using with your computer
- ▶ Printing
- ▶ Troubleshooting
- ▶ Precautions / About this camera

[→ Contents list](#)

Using MENU items (Viewing)

Using MENU items (Viewing)

[Using MENU items \(Viewing\)](#)

MENU items (Viewing)

[Slideshow](#)

[View Mode](#)

[Retouch](#)

[Delete](#)

[Protect](#)

[Print \(DPOF\)](#)

[Rotate](#)

[In-Camera Guide](#)

Playback MENU list

[MENU items that cannot be set according to View Mode](#)

[▲ Back to top](#)

- ▶ [Before Use](#)
- ▶ [Shooting](#)
- ▶ [Viewing](#)
- ▶ [Using MENU items \(Shooting\)](#)
- ▶ [Using MENU items \(Viewing\)](#)
- ▶ [Changing settings](#)
- ▶ [Viewing images on a TV](#)
- ▶ [Using with your computer](#)
- ▶ [Printing](#)
- ▶ [Troubleshooting](#)
- ▶ [Precautions / About this camera](#)

[→ Contents list](#)

Changing settings

Changing settings

[Changing camera settings](#)

Shooting Settings

[AF Illuminator](#)
[Grid Line](#)
[Disp. Resolution](#)
[Digital Zoom](#)
[Red Eye Reduction](#)
[Blink Alert](#)
[Write Date](#)

Main Settings

[Beep](#)
[Panel Brightness](#)
[Language Setting](#)
[Display color](#)
[Demo Mode](#)
[Initialize](#)
[Function Guide](#)
[Video Out](#)
[Eco Mode](#)
[USB Connect Setting](#)
[LUN Setting](#)
[Download Music](#)
[Empty Music](#)
[Eye-Fi](#)

Memory Card Tool/Internal Memory Tool

[Format](#)
[Create REC.Folder](#)
[Change REC.Folder](#)
[Delete REC.Folder](#)
[Copy](#)
[File Number](#)

Clock Settings

[Area Setting](#)
[Date & Time Setting](#)

[▲ Back to top](#)

▶ Before Use

▶ Shooting

▶ Viewing

▶ Using MENU items (Shooting)

▶ Using MENU items (Viewing)

▶ Changing settings

▶ Viewing images on a TV

▶ Using with your computer

▶ Printing

▶ Troubleshooting

▶ Precautions / About this camera

[→ Contents list](#)

Viewing images on a TV

Viewing an image on a Standard Definition (SD) TV

[Viewing an image on a Standard Definition \(SD\) TV](#)

[▲ Back to top](#)

- ▶ [Before Use](#)
- ▶ [Shooting](#)
- ▶ [Viewing](#)
- ▶ [Using MENU items \(Shooting\)](#)
- ▶ [Using MENU items \(Viewing\)](#)
- ▶ [Changing settings](#)
- ▶ [Viewing images on a TV](#)
- ▶ [Using with your computer](#)
- ▶ [Printing](#)
- ▶ [Troubleshooting](#)
- ▶ [Precautions / About this camera](#)

[→ Contents list](#)

Using with your computer

Recommended computer environment

[Recommended computer environment](#)

Using the software

[“PlayMemories Home” \(Windows\)](#)

[Installing “PlayMemories Home” \(Windows\)](#)

[“Music Transfer”](#)

[Software for Mac](#)

Importing images to a computer

[Connecting the camera to the computer](#)

[Importing images to a computer](#)

[Deleting the USB connection](#)

[▲ Back to top](#)

- ▶ Before Use
- ▶ Shooting
- ▶ Viewing
- ▶ Using MENU items (Shooting)
- ▶ Using MENU items (Viewing)
- ▶ Changing settings
- ▶ Viewing images on a TV
- ▶ Using with your computer
- ▶ Printing
- ▶ Troubleshooting
- ▶ Precautions / About this camera

[→ Contents list](#)

Printing

Printing still images

[Printing still images](#)

[▲ Back to top](#)

- ▶ Before Use
- ▶ Shooting
- ▶ Viewing
- ▶ Using MENU items (Shooting)
- ▶ Using MENU items (Viewing)
- ▶ Changing settings
- ▶ Viewing images on a TV
- ▶ Using with your computer
- ▶ Printing
- ▶ Troubleshooting
- ▶ Precautions / About this camera

[→ Contents list](#)

Troubleshooting

If you have problems

[If you have problems](#)

Troubleshooting

[Battery pack and power](#)

[Shooting still images/movies](#)

[Viewing images](#)

[Computers](#)

[Memory card](#)

[Internal memory](#)

[Printing](#)

[Others](#)

Warning indicators and messages

[Self-diagnosis display](#)

[Messages](#)

Difficult situations for this camera

[Situations this camera has difficulty handling](#)

[▲ Back to top](#)

- ▶ Before Use
- ▶ Shooting
- ▶ Viewing
- ▶ Using MENU items (Shooting)
- ▶ Using MENU items (Viewing)
- ▶ Changing settings
- ▶ Viewing images on a TV
- ▶ Using with your computer
- ▶ Printing
- ▶ Troubleshooting
- ▶ Precautions / About this camera

[→ Contents list](#)

Precautions / About this camera

Precautions

[Precautions](#)

[On the internal rechargeable backup battery](#)

[Battery pack](#)

[Battery charger](#)

[Memory card](#)

On cleaning

[On cleaning](#)

Number of still images and recordable time of movies

[Number of still images](#)

[Recordable time of movies](#)

Using the camera abroad

[Using the camera abroad](#)

[On TV color systems](#)

About this camera

[License](#)

Trademarks

[Trademarks](#)

[▲ Back to top](#)

- ▶ Before Use
- ▶ Shooting
- ▶ Viewing
- ▶ Using MENU items (Shooting)
- ▶ Using MENU items (Viewing)
- ▶ Changing settings
- ▶ Viewing images on a TV
- ▶ Using with your computer
- ▶ Printing
- ▶ Troubleshooting
- ▶ Precautions / About this camera

[→ Contents list](#)

Contents list

Before Use

How to use this User Guide

[How to use this User Guide](#)

Names of parts and list of icons displayed on the screen

[Names of parts](#)

[List of icons displayed on the screen](#)

Using the wrist strap

[Using the wrist strap](#)

Using the internal memory

[Using the internal memory](#)

In-Camera Guide

[In-Camera Guide](#)

[▲ Back to top](#)

Shooting

Shooting still images

[Shooting still images](#)

[Zoom](#)

Shooting movies

[Shooting movies](#)

Setting REC mode

[List of mode dial functions](#)

[Intelligent Auto](#)

[Program Auto](#)

[Manual Exposure Shooting](#)

[Scene Selection](#)

[Sweep Panorama](#)

[Movie Mode](#)

[Functions not available in some REC modes](#)

Using shooting functions

[Tracking focus](#)

[DISP \(Display Setting\)](#)

[Flash](#)

[Smile Shutter](#)

[Self-Timer](#)

[▲ Back to top](#)

■ Viewing

Viewing still images

[Viewing still images](#)

[Playback zoom](#)

[Image Index](#)

Deleting images

[Delete button](#)

Viewing movies

[Viewing movies](#)

Viewing panorama images

[Scrolling the panorama images for display](#)

[▲ Back to top](#)

■ Using MENU items (Shooting)

Using MENU items (Shooting)

[Using MENU items \(Shooting\)](#)

MENU items (Shooting)

[Scene Selection](#)

[Easy Mode](#)

[Still Image Size / Panorama Image Size / Movie Size](#)

[Cont. Shooting Settings](#)

[Bracket Setting](#)

[EV](#)

[ISO](#)

[White Balance](#)

[Focus](#)

[Metering Mode](#)

[Scene Recognition](#)

[Soft Skin Effect](#)

[Smile Detection Sensitivity](#)

[Face Detection](#)

[DRO](#)

[Anti Blink](#)

[Movie SteadyShot](#)

[Picture Effect](#)

[Color hue](#)

[Extracted Color](#)

[In-Camera Guide](#)

Shooting MENU list

[MENU items not available in some REC modes](#)

[▲ Back to top](#)

■ Using MENU items (Viewing)

Using MENU items (Viewing)

[Using MENU items \(Viewing\)](#)

MENU items (Viewing)

- Slideshow
- View Mode
- Retouch
- Delete
- Protect
- Print (DPOF)
- Rotate
- In-Camera Guide

Playback MENU list

MENU items that cannot be set according to View Mode

[▲ Back to top](#)

▮ Changing settings

Changing settings

Changing camera settings

Shooting Settings

- AF Illuminator
- Grid Line
- Disp. Resolution
- Digital Zoom
- Red Eye Reduction
- Blink Alert
- Write Date

Main Settings

- Beep
- Panel Brightness
- Language Setting
- Display color
- Demo Mode
- Initialize
- Function Guide
- Video Out
- Eco Mode
- USB Connect Setting
- LUN Setting
- Download Music
- Empty Music
- Eye-Fi

Memory Card Tool/Internal Memory Tool

- Format
- Create REC.Folder
- Change REC.Folder
- Delete REC.Folder
- Copy
- File Number

Clock Settings

Area Setting

▮ Viewing images on a TV

Viewing an image on a Standard Definition (SD) TV

[Viewing an image on a Standard Definition \(SD\) TV](#)

▮ Using with your computer

Recommended computer environment

[Recommended computer environment](#)

Using the software

[“PlayMemories Home” \(Windows\)](#)

[Installing “PlayMemories Home” \(Windows\)](#)

[“Music Transfer”](#)

[Software for Mac](#)

Importing images to a computer

[Connecting the camera to the computer](#)

[Importing images to a computer](#)

[Deleting the USB connection](#)

▮ Printing

Printing still images

[Printing still images](#)

▮ Troubleshooting

If you have problems

[If you have problems](#)

Troubleshooting

[Battery pack and power](#)

[Shooting still images/movies](#)

[Viewing images](#)

[Computers](#)

[Memory card](#)

[Internal memory](#)

[Printing](#)

[Others](#)

Warning indicators and messages

[Self-diagnosis display](#)

[Messages](#)

Difficult situations for this camera

[Situations this camera has difficulty handling](#)

Precautions / About this camera

Precautions

[Precautions](#)

[On the internal rechargeable backup battery](#)

[Battery pack](#)

[Battery charger](#)

[Memory card](#)

On cleaning

[On cleaning](#)

Number of still images and recordable time of movies

[Number of still images](#)

[Recordable time of movies](#)

Using the camera abroad

[Using the camera abroad](#)

[On TV color systems](#)

About this camera

[License](#)

Trademarks

[Trademarks](#)

[▶ Before Use](#)[▶ Shooting](#)[▶ Viewing](#)[▶ Using MENU items \(Shooting\)](#)[▶ Using MENU items \(Viewing\)](#)[▶ Changing settings](#)[▶ Viewing images on a TV](#)[▶ Using with your computer](#)[▶ Printing](#)[▶ Troubleshooting](#)[▶ Precautions / About this camera](#)[→ Contents list](#)

How to use this User Guide

- ▼ [Selecting a topic to display](#)
- ▼ [Searching a topic by keyword](#)
- ▼ [Returning to a previous page](#)
- ▼ [Printing out a page](#)
- ▼ [Marks and notations used in this User Guide](#)

This User Guide explains how to use each function of the camera, how to change settings, and how to troubleshoot a problem.

The images used as examples in this User Guide are reproduced images, and are not actual images shot using this camera.

Selecting a topic to display

The following illustrations take Internet Explorer 7 as an example.

1. Click a title in the side bar on the left of the browser window.
The title's topic list appears in the right pane.
2. Click a topic title in the list.

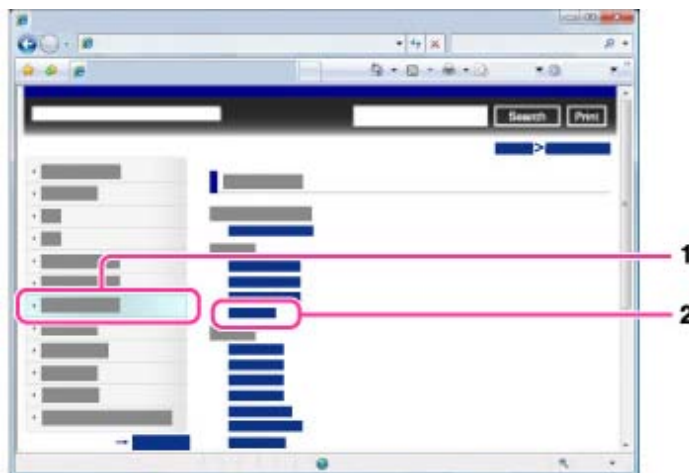

Descriptions appear in the right pane.



Changing the font size

Change the font size by changing the setting of your web browser. For how to change the font size setting, refer to the Help of your web browser.

Searching a topic by keyword

Enter the keyword in the search window, then click the [Search] button.

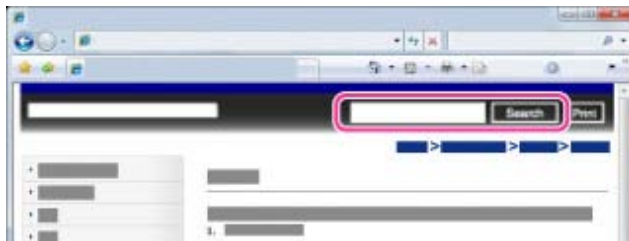

Returning to a previous page

Use the browser's back button to return to a previously viewed page, or use the breadcrumb trail navigation (A) to display the desired page.



Printing out a page

Click the [Print] button to print out a page you are viewing.

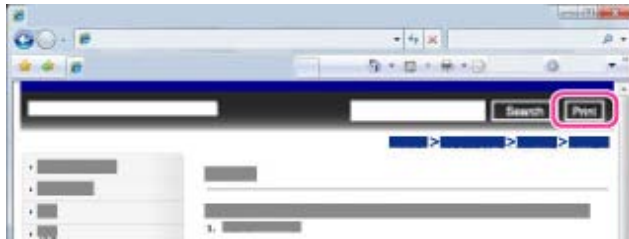

Marks and notations used in this User Guide

In this User Guide, the sequence of operations is shown by arrows (→) (A).
Operate the camera in the order indicated.

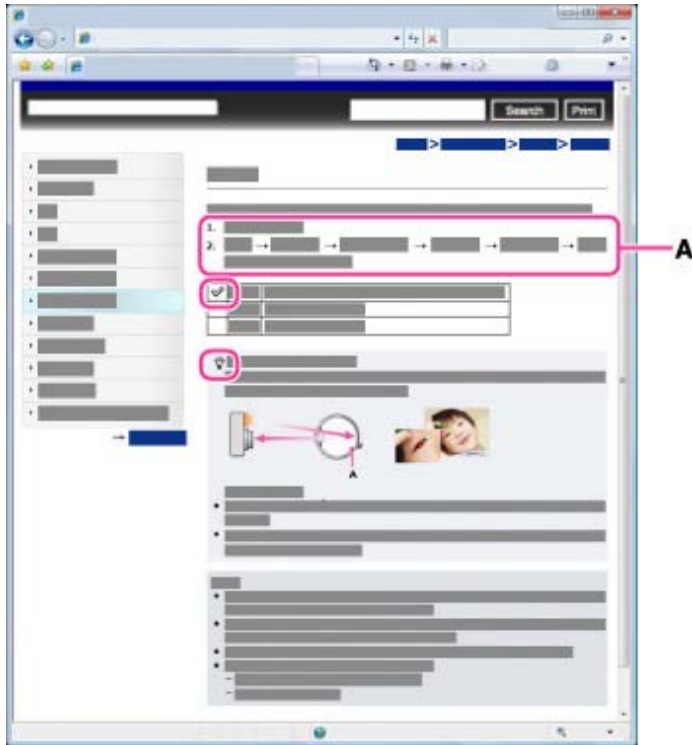

- Icons in the operating procedure sentences appear when the camera is in its default settings.
- The default setting is indicated by ✓.
- 💡 indicates information that is useful to know.

[▲ Back to top](#)

- ▶ Before Use
- ▶ Shooting
- ▶ Viewing
- ▶ Using MENU items (Shooting)
- ▶ Using MENU items (Viewing)
- ▶ Changing settings
- ▶ Viewing images on a TV
- ▶ Using with your computer
- ▶ Printing
- ▶ Troubleshooting
- ▶ Precautions / About this camera

[→ Contents list](#)

Names of parts

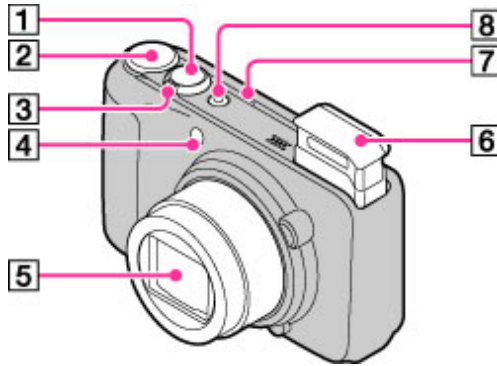

- 1** Shutter button
- 2** Mode dial
- 3** For shooting: W/T (zoom) lever
For viewing: (Index) lever/ (Playback zoom) lever
- 4** Self-timer lamp/Smile Shutter lamp/AF illuminator
- 5** Lens
- 6** Flash
- 7** Speaker
- 8** ON/OFF (Power) button/Power lamp

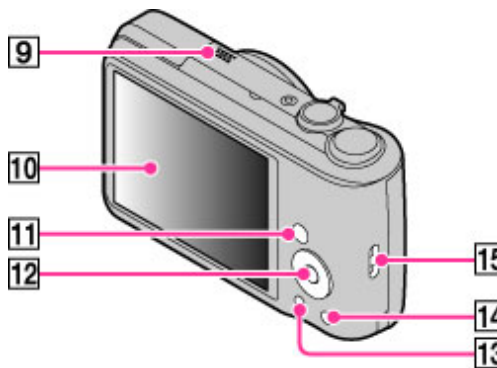

- 9** Microphone
- 10** LCD screen
- 11** (Playback) button
- 12** Control button
MENU on: / / / /
- MENU off: **DISP** / Tracking focus

- 13 MENU button
- 14 ?/□ (In-Camera Guide / Delete) button
- 15 Hook for wrist strap

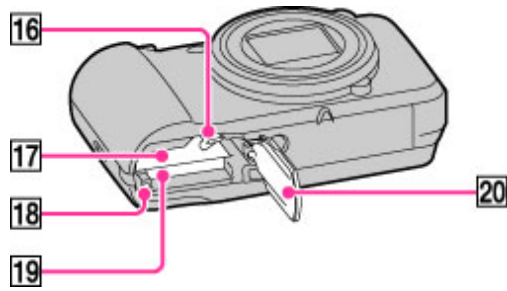

- 16 Battery eject lever
- 17 Battery insertion slot
- 18 Access lamp
- 19 Memory card slot
- 20 Battery/Memory card cover

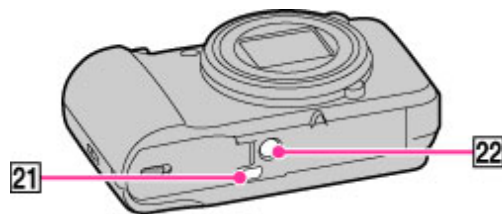

- 21 USB / A/V OUT jack
- 22 Tripod receptacle

[▲ Back to top](#)

Copyright 2012 Sony Corporation

[Top page](#) > [Before Use](#) > [Names of parts and list of icons displayed on the screen](#) > [List of icons displayed on the screen](#)

- ▶ Before Use
- ▶ Shooting
- ▶ Viewing
- ▶ Using MENU items (Shooting)
- ▶ Using MENU items (Viewing)
- ▶ Changing settings
- ▶ Viewing images on a TV
- ▶ Using with your computer
- ▶ Printing
- ▶ Troubleshooting
- ▶ Precautions / About this camera

[→ Contents list](#)

List of icons displayed on the screen

▼ List of shooting mode icons

▼ List of viewing mode icons

Icons are displayed on the screen to indicate the camera status.

You can change the screen display using DISP (Display Setting) on the control button.

List of shooting mode icons

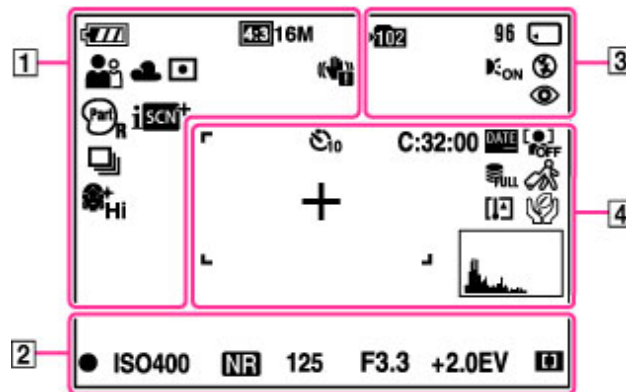

1

Display	Indication
	Battery remaining
	Low battery warning
	Still Image Size / Panorama Image Size / Movie Size
	Scene Selection
	Mode dial
	Scene Recognition icon
	White balance
	Metering Mode
	Vibration warning
	Picture Effect
	Scene Recognition
	Bracket Shooting
	Bracket Setting

	DRO
	Cont. Shooting Settings
	Soft Skin Effect
	Smile Detection Sensitivity indicator
	Zoom scaling

2

Display	Indication
	Anti Blink
	AE/AF lock
ISO400	ISO number
	NR slow shutter
125	Shutter speed
F3.3	Aperture value
+2.0EV	Exposure value
	AF range finder frame indicator

3

Display	Indication
	Recording folder
96	Number of recordable images
100Min	Recordable time
	Recording Media (Memory card, internal memory)
	Eye-Fi Mode display
	AF Illuminator
	Flash mode
	Red-eye reduction
	Flash charging

4

Display	Indication
	Self-timer
C:32:00	Self-diagnosis display
	Write Date

	Face detection
	Database file full/Database file error warning
	Destination
	Overheating warning
	Eco mode
	AF range finder frame
	Spot metering cross-hairs
	Histogram
REC Standby	Recording a movie/Movie standby
0:12	Recording time (m:s)

List of viewing mode icons

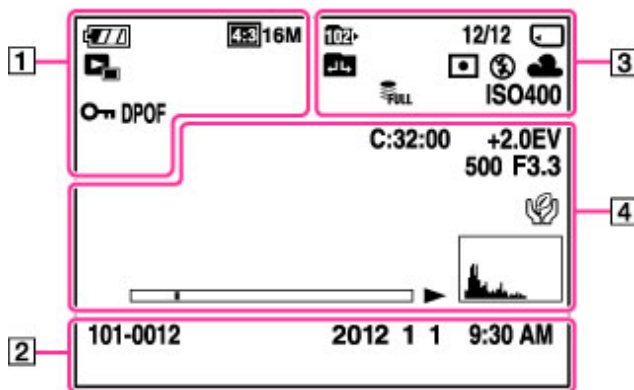

1

Display	Indication
	Battery remaining
	Low battery warning
	Still Image Size / Panorama Image Size / Movie Size
	Protect
DPOF	Print order (DPOF)
Qx2.0	Playback zoom
	View mode

2

Display	Indication
101-0012	Folder-file number
2012 1 1	Recorded date/time of the playback image

3

Display	Indication
	Playback folder
12/12	Image number/Number of images recorded in date range, selected folder
	Playback Media (Memory card, internal memory)
	Eye-Fi Mode display
	Changing folder
	Metering Mode
	Flash mode
	White balance
ISO400	ISO number
	Database file full/Database file error warning

4

Display	Indication
C:32:00	Self-diagnosis display
+2.0EV	Exposure value
500	Shutter speed
F3.3	Aperture value
	Eco mode
	Playback
	Playback bar
00:00:12	Counter
	Histogram
	Volume

[▶ Before Use](#)[▶ Shooting](#)[▶ Viewing](#)[▶ Using MENU items \(Shooting\)](#)[▶ Using MENU items \(Viewing\)](#)[▶ Changing settings](#)[▶ Viewing images on a TV](#)[▶ Using with your computer](#)[▶ Printing](#)[▶ Troubleshooting](#)[▶ Precautions / About this camera](#)[→ Contents list](#)

Using the wrist strap

Attach the strap and place your hand through the loop to prevent the camera from damage by being dropped.

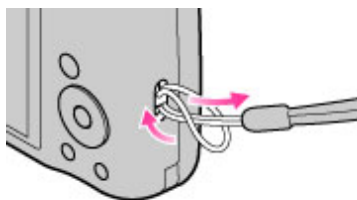
[▲ Back to top](#)

- ▶ Before Use
- ▶ Shooting
- ▶ Viewing
- ▶ Using MENU items (Shooting)
- ▶ Using MENU items (Viewing)
- ▶ Changing settings
- ▶ Viewing images on a TV
- ▶ Using with your computer
- ▶ Printing
- ▶ Troubleshooting
- ▶ Precautions / About this camera

[→ Contents list](#)

Using the internal memory

▼ On image data stored in the internal memory

The camera has approximately 27 MB of internal memory. This memory is not removable. You can record images on the internal memory when there is no memory card inserted in the camera.

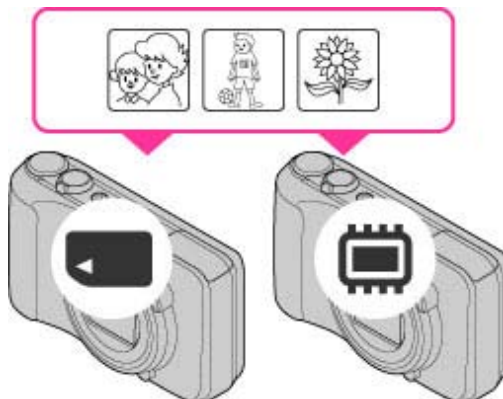

When a memory card is inserted

[Recording]: Images are recorded on the memory card.

[Playback]: Images on the memory card are played back.

[Menu, Settings, etc.]: Various functions can be performed on images on the memory card.

When there is no memory card inserted

[Recording]: Images are recorded using the internal memory.

- You cannot record movies to the internal memory when the movie image size is [1280x720(Fine)] or [1280x720(Standard)].

[Playback]: Images stored in the internal memory are played back.

[Menu, Settings, etc.]: Various functions can be performed on images in the internal memory.

■ On image data stored in the internal memory

We recommend that you copy (back up) data using one of the following methods.

To copy (back up) data on a hard disk of your computer

Without a memory card inserted in the camera, import the images into a computer. [\[Details\]](#)

To copy (back up) data on a memory card

Prepare a memory card with sufficient free capacity, then copy the images in the internal memory to the memory card. [\[Details\]](#)

Notes

- You cannot transfer image data on a memory card to the internal memory.
- By making a USB connection between the camera and a computer with a USB cable, you can transfer data stored in the internal memory to a computer. However you cannot transfer data on a computer to the internal memory.

- ▶ Before Use
- ▶ Shooting
- ▶ Viewing
- ▶ Using MENU items (Shooting)
- ▶ Using MENU items (Viewing)
- ▶ Changing settings
- ▶ Viewing images on a TV
- ▶ Using with your computer
- ▶ Printing
- ▶ Troubleshooting
- ▶ Precautions / About this camera

[→ Contents list](#)

In-Camera Guide

This camera contains an internal function guide. This allows you to search the camera's functions according to your needs.

You can use the selected function after reading the guide.

1. Press the MENU button.
2. Select the desired MENU item using ▲ / ▼ on the control button.
3. Press the ?/☰ (In-Camera Guide) button.
The operation guide for the selected function in step 2 is displayed.
4. Use ▲ / ▼ to switch the display from summary to operation to details.
 - When you select [Use this function], the camera switches to the selected mode automatically.
 - You can search for a function by key word(s) or icon, by pressing the ?/☰ (In-Camera Guide) button when MENU is not displayed.
5. To end [In-Camera Guide], press the ?/☰ (In-Camera Guide) button.

Notes

- ?/☰ (In-Camera Guide) button is not available in Easy Mode.
- [Use this function] may not be available, depending on the selected functions.
- Detailed explanations of the operation or setting items may not be available, depending on the function.

[▲ Back to top](#)

- ▶ Before Use
- ▶ Shooting
- ▶ Viewing
- ▶ Using MENU items (Shooting)
- ▶ Using MENU items (Viewing)
- ▶ Changing settings
- ▶ Viewing images on a TV
- ▶ Using with your computer
- ▶ Printing
- ▶ Troubleshooting
- ▶ Precautions / About this camera

[→ Contents list](#)

Shooting still images

1. Set the mode dial to  (Intelligent Auto), then press the ON/OFF (Power) button.

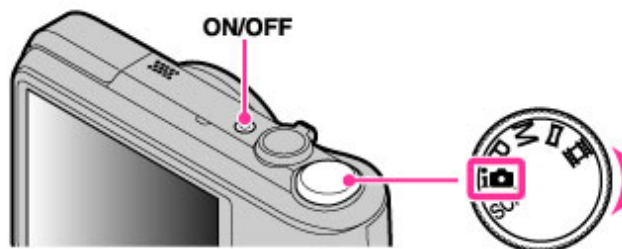

2. Hold the camera steady as illustrated.
 - Do not cover the flash with your fingers.

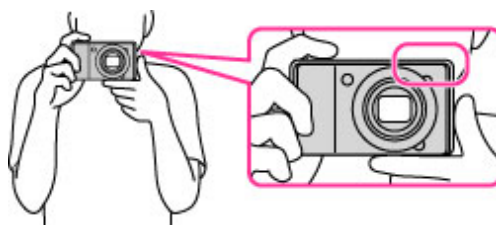

3. Press the shutter button halfway down to focus.

When the image is in focus, a beep sounds and the ● indicator lights.

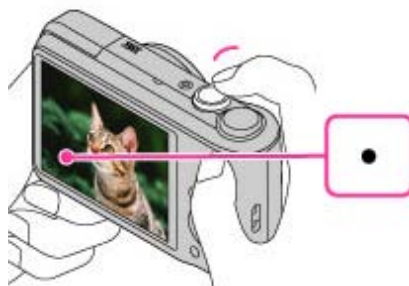

- The shortest shooting distance is approximately 5 cm (2 inches) (W), 120 cm (3 feet 11 1/4 inches) (T) (from the lens).
 - Macro mode may automatically be set depending on the shooting conditions.
4. Press the shutter button fully down.
 - Do not put your fingers on the flash or lens when you shoot still images.
 - When using the flash, the flash (A) pops up automatically.

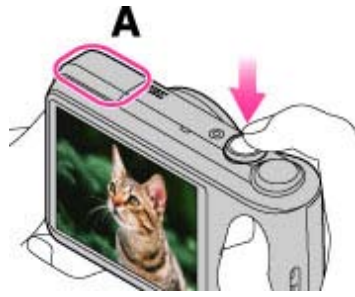

- 💡 If you shoot a still image of a subject that is difficult to focus on
- When the camera cannot focus on the subject automatically, the AE/AF lock indicator changes to slowly flashing and the beep does not sound. Either recompose the shot or change the focus setting. [\[Details\]](#)
 - Focusing may be difficult in the following situations:
 - It is dark and the subject is distant.
 - The contrast between the subject and the background is poor.
 - The subject is seen through glass.
 - The subject is moving quickly.
 - There is reflective light or shiny surfaces.
 - The subject is backlit or there is a flashing light.

Related Topic

[Viewing still images](#)

[Still Image Size / Panorama Image Size / Movie Size](#)

[▲ Back to top](#)

Copyright 2012 Sony Corporation

[▶ Before Use](#)[▶ Shooting](#)[▶ Viewing](#)[▶ Using MENU items \(Shooting\)](#)[▶ Using MENU items \(Viewing\)](#)[▶ Changing settings](#)[▶ Viewing images on a TV](#)[▶ Using with your computer](#)[▶ Printing](#)[▶ Troubleshooting](#)[▶ Precautions / About this camera](#)[→ Contents list](#)

Zoom

You can enlarge the image when shooting. The camera's optical zoom function can enlarge images up to 16×.

1. Turn the W/T (zoom) lever.

Turn the W/T (zoom) lever to T side to zoom in, W side to zoom out.



- Turn the W/T (zoom) lever lightly for a slower zoom. Move it further for a faster zoom.
- When the zoom scale exceeds 16×, set [Digital Zoom]. [\[Details\]](#)

Notes

- Zoom is locked to the W side in Sweep Panorama mode.
- The operating sound of the lens is recorded when the zoom function operates while shooting a movie.

[▲ Back to top](#)

[▶ Before Use](#)[▶ Shooting](#)[▶ Viewing](#)[▶ Using MENU items \(Shooting\)](#)[▶ Using MENU items \(Viewing\)](#)[▶ Changing settings](#)[▶ Viewing images on a TV](#)[▶ Using with your computer](#)[▶ Printing](#)[▶ Troubleshooting](#)[▶ Precautions / About this camera](#)[→ Contents list](#)

Shooting movies

1. Set the mode dial to  (Movie Mode), then press the ON/OFF (Power) button.

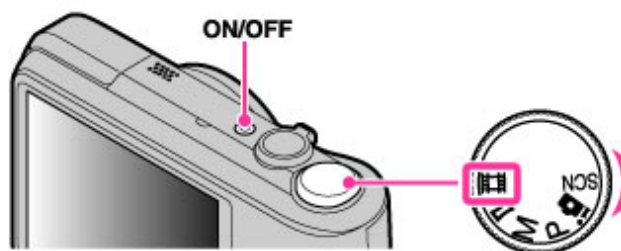

2. Press the shutter button to start recording.



3. Press the shutter button again to stop recording.

Notes

- The operating sound of the lens is recorded when the zoom function operates while shooting a movie.
- You can shoot continuously for approximately 29 minutes at a time when the temperature is 25°C (77°F) and camera is set to the factory settings. When shooting stops, you can press the shutter button again to restart shooting. Depending on the temperature when shooting, recording may automatically stop to protect the camera.

Related Topic

[Zoom](#)

[Still Image Size / Panorama Image Size / Movie Size](#)

[▲ Back to top](#)



- ▶ Before Use
- ▶ Shooting
- ▶ Viewing
- ▶ Using MENU items (Shooting)
- ▶ Using MENU items (Viewing)
- ▶ Changing settings
- ▶ Viewing images on a TV
- ▶ Using with your computer
- ▶ Printing
- ▶ Troubleshooting
- ▶ Precautions / About this camera

[→ Contents list](#)

List of mode dial functions

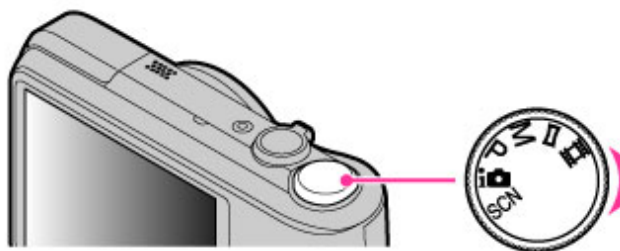
Set the mode dial to the desired function.



 (Intelligent Auto)	Allows you to shoot still images with the settings adjusted automatically.
P (Program Auto)	Allows you to shoot with the exposure adjusted automatically (both the shutter speed and the aperture value (F value)). Also you can select various settings using the menu.
SCN (Scene Selection)	Allows you to shoot with preset settings according to the scene.
M (Manual Exposure Shooting)	Allows you to shoot after adjusting the exposure manually (both the shutter speed and the aperture (F value)).
 (Sweep Panorama)	Allows you to shoot a panorama image after composing images.
 (Movie Mode)	Allows you to change the setting for movie recording.

Related Topic

- [Intelligent Auto](#)
- [Program Auto](#)
- [Scene Selection](#)
- [Manual Exposure Shooting](#)
- [Sweep Panorama](#)
- [Movie Mode](#)

[▲ Back to top](#)

- ▶ Before Use
- ▶ Shooting
- ▶ Viewing
- ▶ Using MENU items (Shooting)
- ▶ Using MENU items (Viewing)
- ▶ Changing settings
- ▶ Viewing images on a TV
- ▶ Using with your computer
- ▶ Printing
- ▶ Troubleshooting
- ▶ Precautions / About this camera

[→ Contents list](#)

Intelligent Auto

Allows you to shoot still images with the setting adjusted automatically.

1. Set the mode dial to  (Intelligent Auto).
2. Shoot with the shutter button.

On Scene Recognition

Scene Recognition operates in Intelligent Auto mode. This function lets the camera automatically recognize the shooting conditions and shoot the image.



Related Topic

[Scene Recognition](#)

[Functions not available in some REC modes](#)

[MENU items not available in some REC modes](#)

[▲ Back to top](#)

[▶ Before Use](#)[▶ Shooting](#)[▶ Viewing](#)[▶ Using MENU items \(Shooting\)](#)[▶ Using MENU items \(Viewing\)](#)[▶ Changing settings](#)[▶ Viewing images on a TV](#)[▶ Using with your computer](#)[▶ Printing](#)[▶ Troubleshooting](#)[▶ Precautions / About this camera](#)[→ Contents list](#)

Program Auto

Allows you to shoot with the exposure adjusted automatically (both the shutter speed and the aperture value). Also you can select various settings using the menu.

1. Set the mode dial to **P** (Program Auto).
2. Shoot with the shutter button.

Related Topic

[Functions not available in some REC modes](#)

[MENU items not available in some REC modes](#)

[▲ Back to top](#)

- ▶ Before Use
- ▶ Shooting
- ▶ Viewing
- ▶ Using MENU items (Shooting)
- ▶ Using MENU items (Viewing)
- ▶ Changing settings
- ▶ Viewing images on a TV
- ▶ Using with your computer
- ▶ Printing
- ▶ Troubleshooting
- ▶ Precautions / About this camera

[→ Contents list](#)

Manual Exposure Shooting

You can shoot at your favorite exposure by manually setting the shutter speed and aperture value.

1. Set the mode dial to **M** (Manual Exposure Shooting).
2. Press **●** on the control button.
3. Select the shutter speed and aperture (F value) using control button.

Control button	Feature
●	Return
▲ ▼	Shutter speed
◀ ▶	Aperture (F value)

- Select a shutter speed from 1/1600 seconds to 30 seconds.
 - When zoom is set fully to W, you can select an aperture of F3.3 or F8.0 (when used with the Internal ND (Neutral Density) Filter).
When zoom is set fully to T, you can select an aperture of F5.9 or F14 (when used with the Internal ND (Neutral Density) Filter).
4. Press the shutter button to shoot the image.

Setting the shutter speed and aperture (F value)

The difference between the settings and proper exposure judged by the camera appears as an EV value on screen.



A: Shutter speed/aperture (F value)

B: EV value

- 0EV is the value judged as the most suitable by the camera.
- When the shutter speed is one second or slower, the shutter speed is indicated by ["], for example, [1"].
- When you set the shutter speed slower, using a tripod is recommended to prevent the effects of vibration.
- When the shutter speed becomes slower than a certain speed, the NR slow shutter function is activated automatically to reduce image noise, and **NR** appears on the screen.
- If you select slow shutter speeds, it takes time to process the data.

Notes

- If proper exposure is not obtained by your settings, the setting value indicators on the screen will flash when the shutter button is pressed halfway down. You can shoot in this condition, but

exposure readjustment is recommended.

- You cannot select the shutter speed and aperture (F value) when the self-timer is set to [Self-portrait One Person] or [Self-portrait Two People].

Related Topic

[Functions not available in some REC modes](#)

[MENU items not available in some REC modes](#)

[▲ Back to top](#)

Copyright 2012 Sony Corporation









- ▶ Before Use
- ▶ Shooting
- ▶ Viewing
- ▶ Using MENU items (Shooting)
- ▶ Using MENU items (Viewing)
- ▶ Changing settings
- ▶ Viewing images on a TV
- ▶ Using with your computer
- ▶ Printing
- ▶ Troubleshooting
- ▶ Precautions / About this camera











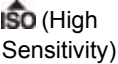

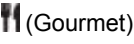
[→ Contents list](#)

Scene Selection

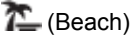
Allows you to shoot with preset settings according to the scene.

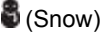
1. Set the mode dial to **SCN** (Scene Selection).
2. Select the desired mode → ● on the control button.
 - If you want to select the other Scene Selection mode, select from MENU.

 (Soft Skin)	<p>Allows you to shoot faces for smoothness.</p> 
 (Soft Snap)	<p>Allows you to shoot images with a softer atmosphere for portraits and flowers, etc.</p> 
 (Landscape)	<p>Allows easy shooting of distant scenes by focusing in the distance. Shoots vivid blue sky and flora colors.</p> 
 (Night Portrait)	<p>Allows you to shoot sharp images of people with the night view in the background without compromising the atmosphere.</p> 
 (Night Scene)	<p>Allows you to shoot night scenes at far distance without losing the dark atmosphere of the surroundings.</p>



	
	<p>Allows you to shoot images without a flash under low light conditions, reducing blur.</p> 
	<p>Allows you to shoot food arrangements in delicious and bright color.</p> 
	<p>Allows you to shoot images of your pet with the best settings.</p> 
	<p>Allows you to shoot scenes on the beach in bright and vivid colors even under the sunlight.</p> 
	<p>Allows you to record images without compromising atmosphere in snowy scenes, etc., where a considerable portion of the image is white.</p> 
	<p>Allows you to record fireworks in all their splendor.</p> 

 (Advanced Sports Shooting)

Allows you to shoot subjects with fast movements such as sports. While the shutter is pressed halfway, the movement of the subject is predicted and the focus will be adjusted.



Note

- When you shoot images using  (Night Portrait),  (Night Scene) or  (Fireworks) mode, the shutter speed is slower and the images tend to blur. To prevent blurring, the use of a tripod is recommended.

Related Topic

[Functions not available in some REC modes](#)

[MENU items not available in some REC modes](#)

[▲ Back to top](#)

Copyright 2012 Sony Corporation





- ▶ Before Use
- ▶ Shooting
- ▶ Viewing
- ▶ Using MENU items (Shooting)
- ▶ Using MENU items (Viewing)
- ▶ Changing settings
- ▶ Viewing images on a TV
- ▶ Using with your computer
- ▶ Printing
- ▶ Troubleshooting
- ▶ Precautions / About this camera

[→ Contents list](#)

Sweep Panorama

Allows you to create a panorama image from composite images.



1. Set the mode dial to  (Sweep Panorama).
2. Select a shooting direction with  /  /  /  (Up/Down/Left/Right) on the control button.
3. Align the camera with the end of the subject to be shot and press the shutter button fully.



A: That part will not be taken.

4. Pan the camera to the end of the guide (B), following the indication on the screen.



Tips for shooting a panorama image

Pan the camera in an arc at a constant velocity in the direction indicated on the screen. Subjects at rest are more suited for panorama shots than moving subjects.
Radius as short as possible.

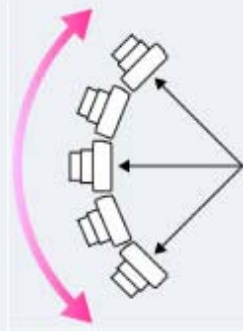

Vertical direction

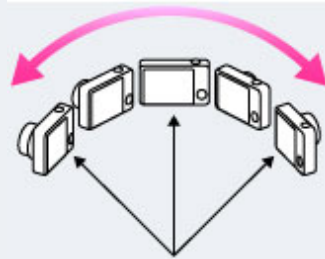

Horizontal direction

- First, press the shutter button halfway so that you can lock the focus, exposure and white balance. Then, press the shutter button fully down and pan or tilt the camera.
- If a section with greatly varied shapes or scenery is concentrated along a screen edge, the image composition may fail. In such case, adjust the frame composition so that the section is in the center of the image, then shoot again.

💡 To shoot a 360 degree panoramic image

This camera is equipped with a panorama shooting function, capable of shooting a near-full 360 degree panoramic image.

Shoot a panoramic image by selecting MENU → set [Panorama Image Size] to [360°]. Recorded panoramic images can be scrolled accurately when played on the camera.

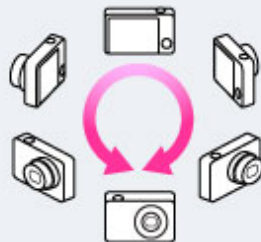

- Select a shooting direction with ◀ / ▶ on the control button. You cannot shoot a panoramic image in a vertical direction with [Panorama Image Size] set to [360°].
- The image actually recorded may not cover 360 degrees, depending on the subject or the way it is shot.

Notes

- If you cannot pan the camera across the entire subject within the given time, a gray area occurs in the composite image. If this happens, move the camera faster to record a full panoramic image.
- Since several images are stitched together, the stitched part will not be recorded smoothly.
- When the whole angle of panoramic shooting and the AE/AF locked angle are very different in brightness, color and focus, the shooting will not be successful. If this happens, change AE/AF locked angle and shoot again.
- You cannot create panorama images in the following situations:
 - You pan the camera too quickly or too slowly.
 - There is too much camera shake.

Related Topic

[Scrolling the panorama images for display](#)

[Still Image Size / Panorama Image Size / Movie Size](#)

[Functions not available in some REC modes](#)

[MENU items not available in some REC modes](#)

[▲ Back to top](#)

Copyright 2012 Sony Corporation

- ▶ [Before Use](#)
- ▶ [Shooting](#)
- ▶ [Viewing](#)
- ▶ [Using MENU items \(Shooting\)](#)
- ▶ [Using MENU items \(Viewing\)](#)
- ▶ [Changing settings](#)
- ▶ [Viewing images on a TV](#)
- ▶ [Using with your computer](#)
- ▶ [Printing](#)
- ▶ [Troubleshooting](#)
- ▶ [Precautions / About this camera](#)

[→ Contents list](#)

Movie Mode

Allows you to record movies with their audio.

1. Set the mode dial to  (Movie Mode).
2. Press the shutter button.
3. To stop recording, press the shutter button again.

Related Topic

[Shooting movies](#)

[Still Image Size / Panorama Image Size / Movie Size](#)

[Functions not available in some REC modes](#)

[MENU items not available in some REC modes](#)

[▲ Back to top](#)

- ▶ Before Use
- ▶ Shooting
- ▶ Viewing
- ▶ Using MENU items (Shooting)
- ▶ Using MENU items (Viewing)
- ▶ Changing settings
- ▶ Viewing images on a TV
- ▶ Using with your computer
- ▶ Printing
- ▶ Troubleshooting
- ▶ Precautions / About this camera

[→ Contents list](#)

Functions not available in some REC modes

- ▼ [Functions available in REC modes](#)
- ▼ [Functions available in Scene Selection](#)
- ▼ [Functions available in Picture Effect](#)

In the table below, a check mark indicates a user-changeable function, while — indicates an unchangeable one. The icons below [Flash] and [Self-Timer] indicate the available modes.















Functions available in REC modes

	Flash	Self-Timer	Face Detection	Smile Shutter	Tracking focus	Cont. Shooting Settings / Bracket Setting
(Intelligent Auto)	AUTO	✓	✓	✓	✓	✓*
P (Program Auto)	✓	✓	✓	✓	✓	✓
M (Manual Exposure Shooting)		✓	✓	✓	—	✓
(Sweep Panorama)		—	—	—	—	—
(Movie Mode)		—	—	—	—	—

* [Bracket Setting] cannot be selected.

Functions available in Scene Selection









	Flash	Self-Timer	Face Detection	Smile Shutter	Tracking focus	Cont. Shooting Settings / Bracket Setting
(Soft Skin)	✓	✓	✓*1	✓	✓	—
(Soft Snap)	✓	✓	✓*1	✓	✓	—
(Landscape)		10 2	—	—	—	✓*2
(Night Portrait)	SL	✓	✓	✓	✓	—
(Night Scene)		10 2	—	—	—	—
ISO (High Sensitivity)		✓	✓	✓	✓	—

 (Gourmet)			—	—	✓	—
 (Pet)			—	—	✓	—
 (Beach)		✓	✓	✓	✓	✓*2
 (Snow)		✓	✓	✓	✓	✓*2
 (Fireworks)			—	—	—	—
 (Advanced Sports Shooting)		—	—	—	—	✓*2

*1 [Off] for [Face Detection] cannot be selected.

*2 [White Balance] for [Bracket Setting] cannot be selected.

Functions available in Picture Effect

	Flash	Self-Timer	Face Detection	Smile Shutter	Tracking focus	Cont. Shooting Settings / Bracket Setting
 (Toy camera)		✓	✓	—	✓	✓*
 (Pop Color)		✓	✓	—	✓	✓*
 (Partial Color)		✓	✓	—	✓	✓*
 (Soft High-key)		✓	✓	—	✓	✓*

* [Bracket Setting] cannot be selected.

[▲ Back to top](#)

- ▶ Before Use
- ▶ Shooting
- ▶ Viewing
- ▶ Using MENU items (Shooting)
- ▶ Using MENU items (Viewing)
- ▶ Changing settings
- ▶ Viewing images on a TV
- ▶ Using with your computer
- ▶ Printing
- ▶ Troubleshooting
- ▶ Precautions / About this camera



[→ Contents list](#)

Tracking focus

Even if a subject is moving, the camera continues to focus automatically.

1. Point the camera at the subject, then press  on the control button.
The target frame appears.



2. Place the target frame over the subject you want to focus on, and press  .
Tracking begins.
3. Press the shutter button fully down to shoot the image.
4. To cancel the tracking focus before shooting, press  again.

Tracking a face

If you use the tracking focus function while the Face Detection function is activated, you can select a face to be given priority and register that face with the camera.

Notes

- When you use the Digital Zoom, the tracking focus function is not available.
- Tracking focus will automatically be canceled when the subject disappears from the screen or has failed to be tracked.

Related Topic

[Face Detection](#)

[Functions not available in some REC modes](#)

[▲ Back to top](#)







- ▶ Before Use
- ▶ Shooting
- ▶ Viewing
- ▶ Using MENU items (Shooting)
- ▶ Using MENU items (Viewing)
- ▶ Changing settings
- ▶ Viewing images on a TV
- ▶ Using with your computer
- ▶ Printing
- ▶ Troubleshooting
- ▶ Precautions / About this camera

[→ Contents list](#)

DISP (Display Setting)

▼ Histogram

1. Press DISP (Display Setting) on the control button.
2. Select the desired mode with the control button.

 (OFF)	Displays only images. 
 (Detailed Info)	Displays Information. Exif data for the recorded image are also displayed. 
  (ON)	Displays information. 

■ Histogram

A histogram is a graph showing the brightness of an image. The graph display indicates a bright image when skewed to the right side (A), and a dark image when skewed to the left side (B).



1. Press DISP (Display Setting) on the control button, then select [Detailed Info].

- The histogram also appears when playing back a single image, but you cannot adjust the exposure.
- The histogram does not appear when:
 - Recording/playing back movies
 - Viewing vertical orientation images
 - Rotating still images
 - Shooting/viewing in Sweep Panorama mode
- A large difference in the histogram displayed during shooting and playback may occur when:
 - The flash strobes.
 - The shutter speed is slow or fast.
- The histogram may not appear for images recorded using other cameras.

[▲ Back to top](#)





Copyright 2012 Sony Corporation

- ▶ Before Use
- ▶ Shooting
- ▶ Viewing
- ▶ Using MENU items (Shooting)
- ▶ Using MENU items (Viewing)
- ▶ Changing settings
- ▶ Viewing images on a TV
- ▶ Using with your computer
- ▶ Printing
- ▶ Troubleshooting
- ▶ Precautions / About this camera

[→ Contents list](#)

Flash

1. Press  (Flash) on the control button.
2. Select the desired mode with the control button.

✓	 AUTO (Auto)	Flash automatically operates in dark locations or when there is backlight.
	 (On)	Flash always operates.
	 SL (Slow Synchro)	Flash always operates. The shutter speed is slow in a dark place to clearly shoot the background that is out of flash light.
	 (Off)	Flash does not operate.

 When the “White circular spots” appears in flash photos





This is caused by particles (dust, pollen, etc.) floating close to the lens. When they are accentuated by the camera’s flash, they appear as white circular spots.



How can the “White circular spots” be reduced?

- Light the room and shoot the subject without a flash.
- Select **ISO** (High Sensitivity) mode in Scene Selection. ([Off] is automatically selected.)

Notes

- The flash strobos twice. The first flash adjusts the light quantity.
- While charging the flash,  is displayed.
- The flash unit pops up automatically before it flashes. Do not cover the flash with your fingers.
- The flash retracts automatically in the following situations:
 - The power is turned on/off, the camera is switched to playback mode or USB mode.
 - The flash mode is set to  (Off).
 - The mode dial is set to  (Sweep Panorama) or  (Movie Mode).
- When you do not want to use the flash, set the flash mode to  (Off) beforehand. This makes the flash unable to pop up.
- Do not push down or pick up the flash with your fingers. This may cause a malfunction.
- You cannot use the flash during burst shooting.
- When shooting with the flash and the zoom is set to W, the shadow of the lens may appear on the screen, depending on the shooting conditions. If this happens, set the zoom to T and shoot with the flash again.

Functions not available in some REC modes

[▲ Back to top](#)

Copyright 2012 Sony Corporation

- ▶ Before Use
- ▶ Shooting
- ▶ Viewing
- ▶ Using MENU items (Shooting)
- ▶ Using MENU items (Viewing)
- ▶ Changing settings
- ▶ Viewing images on a TV
- ▶ Using with your computer
- ▶ Printing
- ▶ Troubleshooting
- ▶ Precautions / About this camera

[→ Contents list](#)

Smile Shutter

When the camera detects a smile, the shutter is released automatically.

1. Press ☺ (Smile) on the control button.
2. Wait for a smile to be detected.

When a smile is detected and the smile level exceeds the ◀ point on the indicator, the camera records images automatically.



- If you press the shutter button during Smile Shutter, the camera shoots the image, and then returns to Smile Shutter mode.

3. To stop shooting, press ☺ (Smile) again.

💡 Tips for better capturing of smiles



- 1 Do not cover the eyes with the bangs. Do not obscure the face by hat, masks, sunglasses, etc.
- 2 Try to orient the face in front of the camera and be as level as possible. Keep the eyes narrowed.
- 3 Give a clear smile with an open mouth. The smile is easier to detect when the teeth are shown.
 - The shutter operates when any person whose face is being detected smiles.
 - You can select the priority subject for face detection with [Face Detection]. To perform smile detection for a different face, change the priority face using ● on the control button. [\[Details\]](#)
 - If a smile is not detected, select MENU → [Smile Detection Sensitivity], then set the value to [Slight Smile].

Notes

- Shooting using the Smile Shutter ends automatically when either the memory card or internal memory becomes full.
- Smiles may not be detected correctly depending on the conditions.
- You cannot use the digital zoom function.

Related Topic

[Smile Detection Sensitivity](#)

[Functions not available in some REC modes](#)

[MENU items not available in some REC modes](#)

[▲ Back to top](#)

Copyright 2012 Sony Corporation







- ▶ Before Use
- ▶ Shooting
- ▶ Viewing
- ▶ Using MENU items (Shooting)
- ▶ Using MENU items (Viewing)
- ▶ Changing settings
- ▶ Viewing images on a TV
- ▶ Using with your computer
- ▶ Printing
- ▶ Troubleshooting
- ▶ Precautions / About this camera

[→ Contents list](#)

Self-Timer



▼ Automatic shooting with Self-portrait timer

1. Press  (Self-Timer) on the control button.
2. Select the desired mode with the control button.

✔	 OFF (Off)	Does not use the self-timer.
	 10 (10sec)	Sets the self-timer to a 10-second delay. When you press the shutter button, the self-timer lamp flashes and a beep sounds until the shutter operates. To cancel, press  again.
	 2 (2sec)	Sets the self-timer to a 2-second delay.
	 (Self-portrait One Person)	Sets the self-timer to Self-portrait timer. When the camera detects the specified number of faces, a beep sounds, and the shutter operates 2 seconds later.
	 (Self-portrait Two People)	

Tips for preventing blur

If your hands or body moves while holding the camera and pressing the shutter button, "Camera shake" occurs.

Camera shake occurs frequently under low-light or slow shutter speed conditions, such as those encountered in  (Night Portrait) or  (Night Scene) mode.



To prevent blurring, shoot with a 2-second delay self-timer and stabilize the camera by holding your arms firmly at your side after pressing the shutter button.

Automatic shooting with Self-portrait timer

Point the lens at yourself so that the specified number of faces appear in the screen and the shutter operates. Do not move your camera after the beep sounds.



- You can also shoot an image by pressing the shutter button during this operation.

Related Topic

[Functions not available in some REC modes](#)

[▲ Back to top](#)

Copyright 2012 Sony Corporation

- ▶ Before Use
- ▶ Shooting
- ▶ Viewing
- ▶ Using MENU items (Shooting)
- ▶ Using MENU items (Viewing)
- ▶ Changing settings
- ▶ Viewing images on a TV
- ▶ Using with your computer
- ▶ Printing
- ▶ Troubleshooting
- ▶ Precautions / About this camera

[→ Contents list](#)

Viewing still images

1. Press the  (Playback) button to switch to playback mode.
2. Select an image with the control button.

Viewing images taken with a different camera

This camera creates an Image Database File on the memory card for recording and playing images. If the camera detects images not registered in the Image Database File on the memory card, a registration screen with the message “Files found which were not recognized Import files” will be displayed. To view unregistered images, register them by selecting [OK].

- Use a sufficiently charged battery to register images. If a battery with a low charge is used to register images, it may not be possible to register all of the data or the data may be corrupted if the battery charge runs out.







[▲ Back to top](#)

- ▶ Before Use
- ▶ Shooting
- ▶ Viewing
- ▶ Using MENU items (Shooting)
- ▶ Using MENU items (Viewing)
- ▶ Changing settings
- ▶ Viewing images on a TV
- ▶ Using with your computer
- ▶ Printing
- ▶ Troubleshooting
- ▶ Precautions / About this camera



[→ Contents list](#)

Playback zoom

Enlarges the image being played back.

1. Press the  (Playback) button to switch to playback mode.
2. Turn the W/T (zoom) lever to T side () during still image playback.
The image is enlarged to twice the previous size, at the center of the image.
3. Adjust the position with  /  /  /  on the control button.
The mark in the lower left of the image shows which part of the total image is being displayed.



4. Change the zoom scale with W/T (zoom) lever.
Turn the W/T (zoom) lever to T side () to zoom in, W side () to zoom out.
Press  on the control button to cancel playback zoom.

| To save enlarged images

You can save an enlarged image by using the trimming function.
Press MENU → [Retouch] → [Trimming (Resize)].



[▲ Back to top](#)

- ▶ Before Use
- ▶ Shooting
- ▶ Viewing
- ▶ Using MENU items (Shooting)
- ▶ Using MENU items (Viewing)
- ▶ Changing settings
- ▶ Viewing images on a TV
- ▶ Using with your computer
- ▶ Printing
- ▶ Troubleshooting
- ▶ Precautions / About this camera



[→ Contents list](#)

Image Index

Displays multiple images at the same time.

1. Press the  (Playback) button to switch to playback mode.
2. Turn the W/T (zoom) lever to W side () to display the image index screen.
Turn the lever again to display an index screen with more images. Turn the lever yet again to view images with the Calendar while playing back in [Date View].
3. To return to the single-image screen, select an image with the control button, then press .

Displaying images of the desired date/folder







Select the left side bar with the control button, then select the desired folder with  / .



Viewing images with the Calendar

When [View Mode] is set to [Date View], turn the W/T (zoom) lever to W side () to view images with the Calendar, while the index displays more images.



- To select the month you want to display, select  /  with the control button, then press .
- To view images in selected date in index mode, select the date with the control button and press .
- To exit the Calendar and display the image index screen again, select  with the control button, then press .



- ▶ Before Use
- ▶ Shooting
- ▶ Viewing
- ▶ Using MENU items (Shooting)
- ▶ Using MENU items (Viewing)
- ▶ Changing settings
- ▶ Viewing images on a TV
- ▶ Using with your computer
- ▶ Printing
- ▶ Troubleshooting
- ▶ Precautions / About this camera

[→ Contents list](#)



Delete button

Allows you to select unwanted images for deletion.

You can also delete images from the MENU button. [\[Details\]](#)

1. Press the  (Playback) button to switch to playback mode.
2.  (Delete) button → desired mode → ● on the control button
3. Press [OK] → ● .

All Images on This Date All in This Folder	Deletes all images in the selected date range or folder at once.
Multiple Images	You can select and delete multiple images. Do as the following after step 2. <ol style="list-style-type: none"> ① Select an image then press ● . Repeat the above steps until there are no more images to be deleted. Select an image with a ✓ mark to release the ✓ mark. ② MENU → [OK] → ●
This Image	Deletes the currently displayed image in single-image mode.
Cancel	Cancels the deletion.

-  You can switch between index and single-image mode when selecting images. Turn the W/T (zoom) lever to T side () in index mode to return to single-image mode, and turn the lever to W side () in single-image mode to return to index mode.
- You can also switch between index and single-image mode in [Protect] or [Print (DPOF)].



Notes

- In Easy Mode, you can only delete the currently displayed image.
- When the internal memory is used to record images, View Mode is set to Folder View and still images and movies are displayed in the same folder.

Related Topic



[Delete](#)

[▲ Back to top](#)







- ▶ Before Use
- ▶ Shooting
- ▶ Viewing
- ▶ Using MENU items (Shooting)
- ▶ Using MENU items (Viewing)
- ▶ Changing settings
- ▶ Viewing images on a TV
- ▶ Using with your computer
- ▶ Printing
- ▶ Troubleshooting
- ▶ Precautions / About this camera

[→ Contents list](#)

Viewing movies

1. Press the  (Playback) button to switch to playback mode.
2. Select a movie with the control button.
3. Press  .
The playback bar appears, and a movie playback starts.



Control button	Feature
	Play/Pause
	Fast forward
	Fast rewind
	Displays the volume control screen. Adjust the volume with  /  on the control button, then press  .

Note

- You may not be able to play back some images shot using other cameras.

Related Topic

[View Mode](#)

[▲ Back to top](#)

[Top page](#) > [Viewing](#) > [Viewing panorama images](#) > [Scrolling the panorama images for display](#)

- ▶ Before Use
- ▶ Shooting
- ▶ Viewing
- ▶ Using MENU items (Shooting)
- ▶ Using MENU items (Viewing)
- ▶ Changing settings
- ▶ Viewing images on a TV
- ▶ Using with your computer
- ▶ Printing
- ▶ Troubleshooting
- ▶ Precautions / About this camera

[→ Contents list](#)

Scrolling the panorama images for display

You can scroll panorama images by pressing center button on the control button while panorama images are being displayed. Turn the W/T (zoom) lever to W side to display the whole image again.



A: Shows the displayed area of the whole panorama image

Control button	Action
● on the control button	Scrolling playback / pauses scrolling images
▲ / ▼ / ◀ / ▶ on the control button	Scrolls images
W side of W/T (zoom) lever	Displays the whole image

- Panorama images recorded using another camera may not scroll correctly when played.

[▲ Back to top](#)

Copyright 2012 Sony Corporation

- ▶ Before Use
- ▶ Shooting
- ▶ Viewing
- ▶ Using MENU items (Shooting)
- ▶ Using MENU items (Viewing)
- ▶ Changing settings
- ▶ Viewing images on a TV
- ▶ Using with your computer
- ▶ Printing
- ▶ Troubleshooting
- ▶ Precautions / About this camera

[→ Contents list](#)

Using MENU items (Shooting)

You can select the various shooting functions easily from the MENU button.

1. Press the ON/OFF (Power) button and set the camera to shooting mode.
2. Press the MENU button to display the Menu screen.

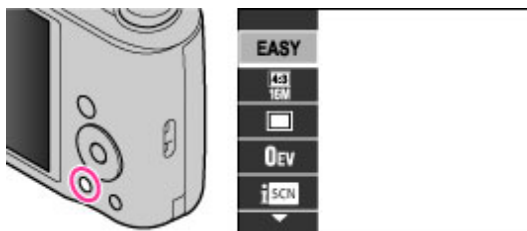

3. Select the desired menu item with ▲ / ▼ / ◀ / ▶ on the control button.

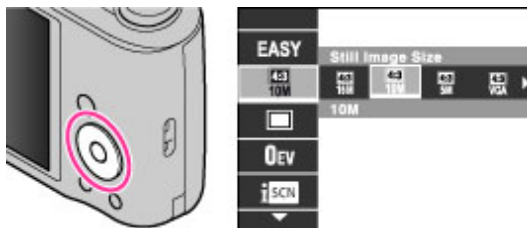

4. Press the MENU button to turn off the Menu screen.

[▲ Back to top](#)









- ▶ Before Use
- ▶ Shooting
- ▶ Viewing
- ▶ Using MENU items (Shooting)
- ▶ Using MENU items (Viewing)
- ▶ Changing settings
- ▶ Viewing images on a TV
- ▶ Using with your computer
- ▶ Printing
- ▶ Troubleshooting
- ▶ Precautions / About this camera













[→ Contents list](#)

Scene Selection

When the mode dial is set to **SCN** (Scene Selection) and if you want to select another scene, follow the steps below.

1. MENU → **SCN** (Scene Selection) → desired mode

 (Soft Skin)	<p>Allows you to shoot faces for smoothness.</p> 
 (Soft Snap)	<p>Allows you to shoot images with a softer atmosphere for portraits and flowers, etc.</p> 
 (Landscape)	<p>Allows easy shooting of distant scenes by focusing in the distance. Shoots vivid blue sky and flora colors.</p> 
 (Night Portrait)	<p>Allows you to shoot sharp images of people with the night view in the background without compromising the atmosphere.</p> 
 (Night Scene)	<p>Allows you to shoot night scenes at far distance without losing the dark atmosphere of the surroundings.</p>



	
 (High Sensitivity)	<p>Allows you to shoot images without a flash under low light conditions, reducing blur.</p> 
 (Gourmet)	<p>Allows you to shoot food arrangements in delicious and bright color.</p> 
 (Pet)	<p>Allows you to shoot images of your pet with the best settings.</p> 
 (Beach)	<p>Allows you to shoot scenes on the beach in bright and vivid colors even under the sunlight.</p> 
 (Snow)	<p>Allows you to record images without compromising atmosphere in snowy scenes, etc., where a considerable portion of the image is white.</p> 
 (Fireworks)	<p>Allows you to record fireworks in all their splendor.</p> 

 (Advanced Sports Shooting)



Allows you to shoot subjects with fast movements such as sports. While the shutter is pressed halfway, the movement of the subject is predicted and the focus will be adjusted.

Note

- When you shoot images using  (Night Portrait),  (Night Scene) or  (Fireworks) mode, the shutter speed is slower and the images tend to blur. To prevent blurring, the use of a tripod is recommended.

Related Topic

[Functions not available in some REC modes](#)

[MENU items not available in some REC modes](#)

[▲ Back to top](#)

Copyright 2012 Sony Corporation

- ▶ Before Use
- ▶ Shooting
- ▶ Viewing
- ▶ Using MENU items (Shooting)
- ▶ Using MENU items (Viewing)
- ▶ Changing settings
- ▶ Viewing images on a TV
- ▶ Using with your computer
- ▶ Printing
- ▶ Troubleshooting
- ▶ Precautions / About this camera

[→ Contents list](#)

Easy Mode

▼ On Scene Recognition

▼ Shooting functions available in Easy Mode (Shooting)

Allows you to shoot still images using the minimum necessary functions. The text size increases and indicators become easier to see.

1. Set the mode dial to  (Intelligent Auto).
2. MENU → **EASY** (Easy Mode) → ● on the control button.
3. [OK] → ●
4. Shoot with the shutter button.
 - To end Easy Mode, MENU → [Exit Easy Mode]

Note

- The battery power may decrease faster because the screen brightness increases automatically.



On Scene Recognition

Scene Recognition operates in Easy Mode. This function lets the camera automatically recognize the shooting conditions and shoot the image.



For details, see “Scene Recognition.” [\[Details\]](#)

Shooting functions available in Easy Mode (Shooting)

Still Image Size	MENU → [Still Image Size] → ● on the control button → desired mode → ● Select between [Large] or [Small] size.
Self-Timer	 on the control button → desired mode Select between [10sec] or [Off] mode.
Flash	 on the control button → desired mode Select between [Auto] or [Off] mode.
Smile Shutter	 on the control button

Related Topic

[Scene Recognition](#)

[▲ Back to top](#)

Copyright 2012 Sony Corporation

- ▶ Before Use
- ▶ Shooting
- ▶ Viewing
- ▶ Using MENU items (Shooting)
- ▶ Using MENU items (Viewing)
- ▶ Changing settings
- ▶ Viewing images on a TV
- ▶ Using with your computer
- ▶ Printing
- ▶ Troubleshooting
- ▶ Precautions / About this camera

[→ Contents list](#)

Still Image Size / Panorama Image Size / Movie Size

- ▼ Image size when shooting still images
- ▼ Image size in Easy Mode
- ▼ Image size when shooting Sweep Panorama
- ▼ Image size when shooting movies

The image size determines the size of the image file that is recorded when you take an image. The larger the image size, the more detail will be reproduced when the image is printed on large-format paper. The smaller the image size, the more images can be recorded.

Image size when shooting still images

1. MENU → 16M (Still Image Size) → desired size

	Still Image Size (Horizontal × Vertical)	Usage guidelines	Number of images	Printing
✓	16M (4608×3456)	For prints up to A3+ size	 	Fine
	10M (3648×2736)	For prints up to A3 size		Rough
	5M (2592×1944)	For prints from 10×15 cm up to A4 size		
	VGA (640×480)	For e-mail attachments	More 	Rough
	12M (4608×2592)	For viewing on a high-definition TV and printing up to A3 size	 	Fine
	2M (1920×1080)	For viewing on a high-definition TV		More

Note

- When you print still images recorded at a 16:9 aspect ratio or panorama images, both edges may be cut off.

Image size in Easy Mode

1. MENU → [Still Image Size] → desired size

<input checked="" type="checkbox"/>	Large	Shoots images in [16M] size.
<input type="checkbox"/>	Small	Shoots images in [5M] size.

Image size when shooting Sweep Panorama

1. MENU →  (Panorama Image Size) → desired size







<input checked="" type="checkbox"/>	 (Standard) (Horizontal: 4912 × 1080) (Vertical: 3424 × 1920)	Shoots images using standard size.
<input type="checkbox"/>	 (Wide) (Horizontal: 7152 × 1080) (Vertical: 4912 × 1920)	Shoots images using wide size.
<input type="checkbox"/>	 (360°) Horizontal: 11520 × 1080	Shoots images using a 360 degree.

Image size when shooting movies

The larger the size of the movie image, the higher the image quality. The higher the amount of data used per second (average bit-rate), the smoother the playback image.

Movies shot with this camera are recorded in MPEG-4 format, at approximately 30 frames/sec, in progressive mode, with AAC audio, mp4 format.

1. MENU →  (Movie Size) → desired size

	Movie Size	Average bit-rate	Usage guidelines
<input checked="" type="checkbox"/>	 1280x720(Fine)	9 Mbps	Shoots highest quality movies for display on High Definition TV.
<input type="checkbox"/>	 1280x720(Standard)	6 Mbps	Shoots standard quality movies for display on High Definition TV.
<input type="checkbox"/>	 VGA	3 Mbps	Shoots an image size suitable for WEB upload.

Note

- A telephoto image results if [VGA] image size is selected when shooting movies.

[▲ Back to top](#)



- ▶ Before Use
- ▶ Shooting
- ▶ Viewing
- ▶ Using MENU items (Shooting)
- ▶ Using MENU items (Viewing)
- ▶ Changing settings
- ▶ Viewing images on a TV
- ▶ Using with your computer
- ▶ Printing
- ▶ Troubleshooting
- ▶ Precautions / About this camera

[→ Contents list](#)

Cont. Shooting Settings

You can select Single Shooting or Continuous Shooting as the shooting mode.

1. MENU →  (Cont. Shooting Settings) → desired mode

	 (Single Shooting)	The camera shoots a single image.
	 (Continuous Shooting)	The camera shoots up to 100 continuous frames in one burst when you hold down the shutter button.

Notes

- [Flash] is set to [Off].
- When recording continuously with the self-timer, a series of up to 5 images are recorded regardless of the time the shutter button is pressed.
- The recording interval becomes longer, depending on the setting for the image size.
- [Focus], [White Balance], and [EV] are adjusted for the first image, and these settings are also used for the other images.
- When the internal memory or a memory card is full, the burst stops.

Related Topic

[Functions not available in some REC modes](#)

[MENU items not available in some REC modes](#)

[▲ Back to top](#)







- ▶ Before Use
- ▶ Shooting
- ▶ Viewing
- ▶ Using MENU items (Shooting)
- ▶ Using MENU items (Viewing)
- ▶ Changing settings
- ▶ Viewing images on a TV
- ▶ Using with your computer
- ▶ Printing
- ▶ Troubleshooting
- ▶ Precautions / About this camera

[→ Contents list](#)

Bracket Setting

You can set the type of the bracket shooting. In the bracket shooting mode, you can record a series of 3 images with the setting changed. You can select the most suitable image afterwards.

1. MENU →  (Bracket Setting) → desired mode

	 (Off)	Does not use the bracket shooting.
	 (EXP ±0.3)	
	 (EXP ±0.7)	Records a series of 3 images with the exposure shifted in the following order: standard, dark, and bright. The larger the bracket step value, the larger the shift of the exposure value.
	 (EXP ±1.0)	
	 (White Balance)	Records a series of 3 images with the white balance shifted in the following order: current color tone, toward blue, and toward red. <ul style="list-style-type: none"> • When you set [White Balance] to other than [Auto], the color tone is shifted based on the selected white balance.

Note

- You cannot select [White Balance] when the mode dial is set to **SCN** (Scene Selection).

Related Topic

[Functions not available in some REC modes](#)[MENU items not available in some REC modes](#)[▲ Back to top](#)

- ▶ Before Use
- ▶ Shooting
- ▶ Viewing
- ▶ Using MENU items (Shooting)
- ▶ Using MENU items (Viewing)
- ▶ Changing settings
- ▶ Viewing images on a TV
- ▶ Using with your computer
- ▶ Printing
- ▶ Troubleshooting
- ▶ Precautions / About this camera

[→ Contents list](#)

EV

You can adjust the exposure manually in 1/3 EV steps in a range of -2.0 EV to +2.0 EV.

1. MENU → **0EV** (EV) → desired EV setting

 Adjusting the exposure for better looking images



A: Overexposure (too much light)

B: Correct exposure

C: Underexposure (too little light)

- When the image shot is overexposed, adjust [EV] to the minus side.
- When the image shot is underexposed, adjust [EV] to the plus side.

Note

- If you shoot a subject in extremely bright or dark conditions, or when you use the flash, the exposure adjustment may not be effective.

Related Topic

[MENU items not available in some REC modes](#)

[▲ Back to top](#)

- ▶ Before Use
- ▶ Shooting
- ▶ Viewing
- ▶ Using MENU items (Shooting)
- ▶ Using MENU items (Viewing)
- ▶ Changing settings
- ▶ Viewing images on a TV
- ▶ Using with your computer
- ▶ Printing
- ▶ Troubleshooting
- ▶ Precautions / About this camera

[→ Contents list](#)

ISO

Adjusts the luminous sensitivity when the camera is set to Program Auto. You can only set [Auto] and cannot select the ISO sensitivity when shooting a movie.

1. MENU → ^{ISO}AUTO (ISO) → desired mode

✓	ISO AUTO (Auto)	Sets the ISO sensitivity automatically.
	ISO ISO ISO ISO 80/100/200/400/ ISO ISO ISO 800/1600/3200	You can reduce image blurring in dark locations or with moving subjects by increasing the ISO sensitivity (select a larger number).



Adjusting ISO Sensitivity (Recommended Exposure Index)

ISO sensitivity is a speed rating for recording media that incorporates an image sensor that receives light. Even when the exposure is the same, images differ depending on the ISO sensitivity.

High ISO sensitivity



Records a bright image even in dark locations while increasing shutter speed to reduce blur.

However, the image tends to become noisy.

Low ISO sensitivity



Records a smoother image.

However, when the exposure is insufficient, the image may become darker.

Related Topic

[MENU items not available in some REC modes](#)

[▲ Back to top](#)

- ▶ Before Use
- ▶ Shooting
- ▶ Viewing
- ▶ Using MENU items (Shooting)
- ▶ Using MENU items (Viewing)
- ▶ Changing settings
- ▶ Viewing images on a TV
- ▶ Using with your computer
- ▶ Printing
- ▶ Troubleshooting
- ▶ Precautions / About this camera











[→ Contents list](#)

White Balance

▼ To capture the basic white color in [One Push Set] mode

Adjusts color tones according to the surrounding light conditions. Use this function if image color appears unnatural.

1. MENU →  (White Balance) → desired mode

✓	 (Auto)	Adjusts the white balance automatically so that the colors appear natural.
	 (Daylight)	Adjusts for outdoors conditions on a fine day, evening views, night scenes, neon signs, fireworks, etc.
	 (Cloudy)	Adjusts for a cloudy sky or a shady location.
	 (Fluorescent White Balance 1)  (Fluorescent White Balance 2)  (Fluorescent White Balance 3)	[Fluorescent White Balance 1]: Adjusts for white fluorescent lighting. [Fluorescent White Balance 2]: Adjusts for natural white fluorescent lighting. [Fluorescent White Balance 3]: Adjusts for day white fluorescent lighting.
	 (Incandescent)	Adjusts for places under incandescent lamp, or under bright lighting, such as in a photo studio.
	 (Flash)	Adjusts for the flash conditions.
	 (One Push)	Adjusts the white balance depending on the light source. Use this mode when [Auto] and other settings don't provide accurate colors.
	 (One Push Set)	Memorizes the basic white color which will be used in [One Push] mode. [Details]

Effects of lighting conditions

The apparent color of the subject is affected by the lighting conditions.

The color tones are adjusted automatically, but you can adjust color tones manually using the White Balance function.



Daylight (White as Standard)



Cloudy (Bluish)



Fluorescent (Green-tinged)



Incandescent (Reddish)

Notes

- When shooting with a flash in other than [Flash] mode, [White Balance] is set to [Auto].
- When [Flash] is [On] or [Slow Synchro], the white balance can only be adjusted to [Auto], [Flash], [One Push] or [One Push Set].
- [One Push Set] cannot be selected while charging the flash.

To capture the basic white color in [One Push Set] mode

1. Frame a white object such as a piece of paper filling the screen under the same lighting conditions as you will shoot the subject.
2. MENU → **WB AUTO** (White Balance) → [One Push Set] → ● on the control button
The screen momentarily turns black, and when the white balance has been adjusted and stored in the memory, the recording screen is displayed again.

Notes

- If the  indicator flashes while shooting, the white balance is either not set or cannot be set. Use automatic white balance.
- Do not shake or strike the camera while [One Push Set] is in progress.
- When flash mode is set to [On] or [Slow Synchro], the white balance is adjusted to the condition with the flash emitting.

Related Topic

[MENU items not available in some REC modes](#)

[▲ Back to top](#)

- ▶ Before Use
- ▶ Shooting
- ▶ Viewing
- ▶ Using MENU items (Shooting)
- ▶ Using MENU items (Viewing)
- ▶ Changing settings
- ▶ Viewing images on a TV
- ▶ Using with your computer
- ▶ Printing
- ▶ Troubleshooting
- ▶ Precautions / About this camera

[→ Contents list](#)

FOCUS







▼ Focusing on subjects near the edge of the screen

You can change the focus method. Use the menu when it is difficult to get the proper focus in auto focus mode.

AF stands for “Auto Focus,” a function that adjusts the focus automatically.

The selected AF range finder frame appears on the screen.

1. MENU →  (Focus) → desired mode

 (Multi AF)	<p>Focuses on a subject in all ranges of the finder frame automatically. When you press the shutter button halfway down in still image shooting mode, a green frame is displayed around the area that is in focus.</p>  <ul style="list-style-type: none"> ● When the Face Detection function is active, AF operates with priority on faces.
 (Center AF)	<p>Focuses on a subject in the center of the finder frame automatically. Using the AF lock function together, you can compose the image the way you want.</p> 
 (Spot AF)	<p>Focuses on an extremely small subject or a narrow area automatically. Using the AF lock function together, you can compose the image the way you want.</p>  <ul style="list-style-type: none"> ● Hold the camera steady so as not to misalign the subject and the AF range finder frame.

Notes

- When you use [Digital Zoom] or [AF Illuminator], the AF range finder frame is disabled and appears in a dotted line. In this case, the camera works to focus on the subjects at the center of the screen.
- If Tracking focus is activated, the camera focuses with priority on the subject to be tracked.

■ Focusing on subjects near the edge of the screen

If the subject is out of focus, do as follows:



1. Recompose the shot so that the subject is centered in the AF range finder (A), and press the shutter button halfway to focus on the subject (AF lock).
2. When the AE/AF lock indicator (B) stops flashing and remains on, return to the fully composed shot, and press the shutter button fully down.
 - As long as you do not press the shutter button fully down, you can retry the procedure as many times as necessary.

Related Topic

[Tracking focus](#)

[MENU items not available in some REC modes](#)

[▲ Back to top](#)

Copyright 2012 Sony Corporation





- ▶ Before Use
- ▶ Shooting
- ▶ Viewing
- ▶ Using MENU items (Shooting)
- ▶ Using MENU items (Viewing)
- ▶ Changing settings
- ▶ Viewing images on a TV
- ▶ Using with your computer
- ▶ Printing
- ▶ Troubleshooting
- ▶ Precautions / About this camera

[→ Contents list](#)

Metering Mode

Selects the metering mode that sets which part of the subject to measure to determine the exposure.

1. MENU →  (Metering Mode) → desired mode

<input checked="" type="checkbox"/>	 (Multi)	Divides into multiple regions and measures each region. The camera determines a well-balanced exposure (Multi-pattern metering).
<input type="checkbox"/>	 (Center)	Measures the center of the image, and determines the exposure based on the brightness of the subject there (Center-weighted metering).
<input type="checkbox"/>	 (Spot)	Align the spot metering cross hairs (A) on the subject to meter one part of the subject (Spot metering). This function is useful when the subject is backlit or when there is strong contrast between the subject and the background. 

Related Topic

[MENU items not available in some REC modes](#)

[▲ Back to top](#)

- ▶ Before Use
- ▶ Shooting
- ▶ Viewing
- ▶ Using MENU items (Shooting)
- ▶ Using MENU items (Viewing)
- ▶ Changing settings
- ▶ Viewing images on a TV
- ▶ Using with your computer
- ▶ Printing
- ▶ Troubleshooting
- ▶ Precautions / About this camera

[→ Contents list](#)

Scene Recognition

▼ Advanced mode

The camera automatically detects shooting conditions, and then takes the shot. When a motion is detected, the ISO sensitivity is increased according to the movement to reduce subject blur. When the camera is set to Intelligent Auto mode, you can select [Advanced] mode, in which the camera automatically shoots two images.



In Scene Recognition, the position of an icon displayed on the screen is different depending on the circumstances. It depends on whether the camera recognizes a scene or condition. If the camera recognizes a scene, icons and guides such as (Portrait), (Infant), (Night Portrait), (Night Scene), (Backlight Portrait), (Backlight), (Landscape), (Macro), (Spotlight) or (Low Light) are displayed on the first line. If the camera recognizes a condition, icons such as (Tripod) or (Move) are displayed on the second line. The camera may recognize both the scene and condition, or just one.







1. MENU → (Scene Recognition) → desired mode





✓	(Auto)	When the camera recognizes the scene, it switches to the optimal settings and shoots the image.
	(Advanced)	<p>When the camera recognizes the scene, it switches to the optimal settings. When the camera recognizes (Night Scene), (Night Portrait), (Backlight) or (Backlight Portrait), it automatically changes the setting and shoots another image.</p> <ul style="list-style-type: none"> • When you shoot two images consecutively, the + mark on the icon will turn green. • When two frames are shot, the two images are displayed side by side immediately after shooting. • When [Anti Blink] is displayed, 2 images are taken automatically and the image with the eyes open is selected automatically. [Details]

Notes

- Scene Recognition function does not operate when you shoot images using digital zoom.
- The available flash settings are [Auto] and [Off].
- These scenes may not be recognized depending on the situation.
- In Tracking focus mode, (Portrait), (Infant), (Night Portrait) or (Backlight Portrait) are not recognized.
- If the environment causes vibrations to be transferred to the camera when (Tripod) and (Night Scene) condition are recognized at the same time, (Tripod) conditions may not be recognized.
- Sometimes a slow shutter results when (Tripod) and (Night Scene) condition are recognized at the same time. Keep the camera still during shooting.



Advanced mode

In [Advanced] mode, the camera shoots two images consecutively with the settings differing as follows when it recognizes  (Night Scene),  (Night Portrait),  (Backlight) or  (Backlight Portrait) scenes, which tend to blur or when  (Night Scene) and  (Tripod) conditions are recognized at the same time. You can select the desired image from the two images shot.

	First Image*	Second Image
	Shoots in Slow Synchro	Shoots with sensitivity increased and shake reduced
	Shoots in Slow Synchro with the face which the flash strobos on as guide	Shoots with sensitivity increased with the face as guide and shake reduced
	Shoots in Slow Synchro	Shoots with a slower shutter speed without increasing sensitivity
	Shoots with the flash	Shoots with the brightness and contrast of the background adjusted
	Shoots with the face which the flash strobos on as guide	Shoots with the brightness and contrast of the face and the background adjusted

* When [Flash] is set to [Auto].

What is the Anti Blink function?

When set to [Advanced], the camera automatically shoots two images consecutively* when it recognizes  (Portrait) or  (Infant). The camera will select, display, and record the image which the eyes are not blinked automatically. If the eyes are closed in both images, the message “Blinked eye detected” is displayed.

* except when the flash strobos/when the shutter speed is slow

Related Topic

[MENU items not available in some REC modes](#)

[▲ Back to top](#)

Copyright 2012 Sony Corporation





- ▶ Before Use
- ▶ Shooting
- ▶ Viewing
- ▶ Using MENU items (Shooting)
- ▶ Using MENU items (Viewing)
- ▶ Changing settings
- ▶ Viewing images on a TV
- ▶ Using with your computer
- ▶ Printing
- ▶ Troubleshooting
- ▶ Precautions / About this camera

[→ Contents list](#)

Soft Skin Effect

When the Face Detection function is activated, sets whether to use the Soft Skin effect, and the effect level.

1. MENU →  (Soft Skin Effect) → desired mode

	 OFF (Off)	Does not use the Soft Skin Effect.
	 Lo (Low)	Adds light, moderate or strong Soft Skin Effect.
	 Mid (Mid)	
	 Hi (High)	

Note

- The [Soft Skin Effect] may not be visible depending on the subject.

Related Topic

[MENU items not available in some REC modes](#)

[▲ Back to top](#)



- ▶ Before Use
- ▶ Shooting
- ▶ Viewing
- ▶ Using MENU items (Shooting)
- ▶ Using MENU items (Viewing)
- ▶ Changing settings
- ▶ Viewing images on a TV
- ▶ Using with your computer
- ▶ Printing
- ▶ Troubleshooting
- ▶ Precautions / About this camera

[→ Contents list](#)

Smile Detection Sensitivity

Sets the sensitivity of the Smile Shutter function for detecting smiles.

1. MENU →  (Smile Detection Sensitivity) → desired mode

	 (Big Smile)	
<input checked="" type="checkbox"/>	 (Normal Smile)	Detects a big, normal or slight smile.
	 (Slight Smile)	

Note

- Smiles may not be detected correctly depending on the conditions.

Related Topic

[Smile Shutter](#)

[MENU items not available in some REC modes](#)

[▲ Back to top](#)

- ▶ [Before Use](#)
- ▶ [Shooting](#)
- ▶ [Viewing](#)
- ▶ [Using MENU items \(Shooting\)](#)
- ▶ [Using MENU items \(Viewing\)](#)
- ▶ [Changing settings](#)
- ▶ [Viewing images on a TV](#)
- ▶ [Using with your computer](#)
- ▶ [Printing](#)
- ▶ [Troubleshooting](#)
- ▶ [Precautions / About this camera](#)

[→ Contents list](#)



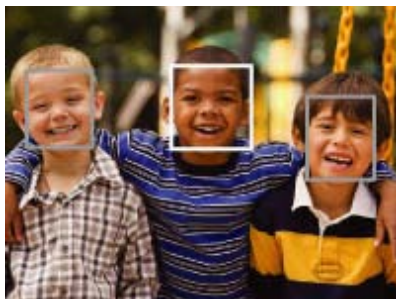

Face Detection

When the Face Detection function is used, the camera detects the faces of your subjects and adjusts the focus, flash, exposure, white balance and red-eye reduction settings automatically.



When the camera detects more than one subject, the camera will judge which is the main subject and set focus by priority. The frame for which the focus is set will turn green by pressing the shutter button halfway down.

1. MENU →  (Face Detection) → desired mode

	[Off] (Off)	Cannot use Face Detection.
	 (Auto)	Selects the face the camera is to automatically focus on.
	(Child Priority)	Detects and shoots with priority on child's face.
	(Adult Priority)	Detects and shoots with priority on adult's face.

Notes

- [Off] is not available when [Self-Timer] is set to [Self-portrait One Person] or [Self-portrait Two People].
- You can select [Face Detection] only when the focus mode is set to [Multi AF] and the [Metering Mode] is set to [Multi].
- The Face Detection function does not work when using the digital zoom.
- Up to 8 faces of your subjects can be detected.
- Adults and children may not be recognized correctly depending on the conditions.
- During Smile Shutter shooting, [Face Detection] is automatically set to [Auto] even if it is set to [Off].

Related Topic

[Anti Blink](#)

[Tracking focus](#)

[MENU items not available in some REC modes](#)

[▲ Back to top](#)

- ▶ Before Use
- ▶ Shooting
- ▶ Viewing
- ▶ Using MENU items (Shooting)
- ▶ Using MENU items (Viewing)
- ▶ Changing settings
- ▶ Viewing images on a TV
- ▶ Using with your computer
- ▶ Printing
- ▶ Troubleshooting
- ▶ Precautions / About this camera





[→ Contents list](#)

DRO

The camera analyzes the shooting scene and automatically corrects the brightness and contrast to improve the image quality.

DRO stands for “Dynamic Range Optimizer,” a function that automatically optimizes the difference between light and dark parts of an image.

1. MENU →  (DRO) → desired mode

	 (Off)	Does not adjust.
	 (DRO Standard)	Adjusts the brightness and contrast of the images automatically.
	 (DRO plus)	Adjusts image brightness and contrast automatically and strongly.

Notes

- Depending on shooting conditions, it may not be possible to obtain correction effects.
- Only [ISO AUTO] or values from [ISO 80] to [ISO 800] can be set for the ISO value when [DRO plus] is set.

[▲ Back to top](#)



- ▶ [Before Use](#)
- ▶ [Shooting](#)
- ▶ [Viewing](#)
- ▶ [Using MENU items \(Shooting\)](#)
- ▶ [Using MENU items \(Viewing\)](#)
- ▶ [Changing settings](#)
- ▶ [Viewing images on a TV](#)
- ▶ [Using with your computer](#)
- ▶ [Printing](#)
- ▶ [Troubleshooting](#)
- ▶ [Precautions / About this camera](#)

[→ Contents list](#)

Anti Blink

When Scene Selection is set to [Soft Snap] and the subject blinks while you are shooting an image, the camera automatically shoots two images consecutively. The camera will select, display and record the image which the eyes are not blinked automatically.

1. MENU →  (Anti Blink) → desired mode

	 (Auto)	When Face Detection is active, the Anti Blink function operates so that images with the subject's eyes open are recorded.
	 (Off)	Does not use the Anti Blink function.

Notes

- Anti Blink does not function in the following situations:
 - When using the flash
 - During burst shooting
 - When the Face Detection function does not work
 - When the Smile Shutter function is activated
- Sometimes the Anti Blink function does not work depending on the situation.
- When the Anti Blink function is set to [Auto] but only images with the subject's eyes closed are recorded, the message "Blinked eye detected" is displayed on the screen. Shoot again as necessary.

Related Topic

[Scene Selection](#)

[▲ Back to top](#)



- ▶ Before Use
- ▶ Shooting
- ▶ Viewing
- ▶ Using MENU items (Shooting)
- ▶ Using MENU items (Viewing)
- ▶ Changing settings
- ▶ Viewing images on a TV
- ▶ Using with your computer
- ▶ Printing
- ▶ Troubleshooting
- ▶ Precautions / About this camera

[→ Contents list](#)

Movie SteadyShot

The strength of the SteadyShot effect when shooting movies can be adjusted.

1. MENU →  (Movie SteadyShot) → desired mode

	(Standard)	Provides the SteadyShot effect under stable recording conditions.
	(Active)	Provides a more powerful SteadyShot effect.

Note

- If you change the setting for [Movie SteadyShot], the angle of view will change.

Related Topic

[Shooting movies](#)

[MENU items not available in some REC modes](#)

[▲ Back to top](#)









- ▶ Before Use
- ▶ Shooting
- ▶ Viewing
- ▶ Using MENU items (Shooting)
- ▶ Using MENU items (Viewing)
- ▶ Changing settings
- ▶ Viewing images on a TV
- ▶ Using with your computer
- ▶ Printing
- ▶ Troubleshooting
- ▶ Precautions / About this camera

[→ Contents list](#)

Picture Effect

Allows you to shoot a still image with an original texture according to the desired effect.

1. Set the mode dial to **P** (Program Auto) or **M** (Manual Exposure Shooting).
2. MENU →  (Picture Effect) → desired mode
 - If you want to switch to another effect, press the MENU button.

 (Off)	Does not use the Picture Effect function.
 (Toy camera)	Allows you to shoot images with effects, such as high contrast to provide the impression of a toy camera. You can adjust the color hue by selecting MENU → [Color hue]. 
 (Pop Color)	Allows you to shoot a pop art-like colorful image with emphasis on the color tone. 
 (Partial Color)	Allows you to shoot striking images by changing unspecified colors into monochrome. You can select the color to extract by selecting MENU → [Extracted Color]. 
 (Soft High-key)	Allows you to shoot soft, clear images with an emphasis on brightness. 

Related Topic

[Color hue](#)

[Extracted Color](#)

[Functions not available in some REC modes](#)

[MENU items not available in some REC modes](#)

[▲ Back to top](#)

Copyright 2012 Sony Corporation





- ▶ Before Use
- ▶ Shooting
- ▶ Viewing
- ▶ Using MENU items (Shooting)
- ▶ Using MENU items (Viewing)
- ▶ Changing settings
- ▶ Viewing images on a TV
- ▶ Using with your computer
- ▶ Printing
- ▶ Troubleshooting
- ▶ Precautions / About this camera

[→ Contents list](#)

Color hue

When you select [Toy camera] in Picture Effect, adjust the color hue.

1. MENU →  (Color hue) → desired mode

✓	 (Normal)	Adds a normal hue and darkens the surroundings.
	 (Cool hue)	Adds a bluish cool hue and darkens the surroundings.
	 (Warm hue)	Adds a reddish warm hue and darkens the surroundings.
	 (Green hue)	Adds a green filter-like hue and darkens the surroundings.
	 (Magenta hue)	Adds a magenta filter-like hue and darkens the surroundings.

Note

- It is recommended that you shoot a test image in advance for some subjects.

Related Topic

[Picture Effect](#)

[MENU items not available in some REC modes](#)

[▲ Back to top](#)



- ▶ Before Use
- ▶ Shooting
- ▶ Viewing
- ▶ Using MENU items (Shooting)
- ▶ Using MENU items (Viewing)
- ▶ Changing settings
- ▶ Viewing images on a TV
- ▶ Using with your computer
- ▶ Printing
- ▶ Troubleshooting
- ▶ Precautions / About this camera

[→ Contents list](#)

Extracted Color

When you select [Partial Color] in Picture Effect, select the color to extract.

1. MENU →  (Extracted Color) → desired mode

✓	 (Red)	Extracts red only.
	 (Green)	Extracts green only.
	 (Blue)	Extracts blue only.
	 (Yellow)	Extracts yellow only.

Note

- When [Partial Color] is selected, images may not retain the selected color, depending on the subject.

Related Topic

[Picture Effect](#)

[MENU items not available in some REC modes](#)

[▲ Back to top](#)

- ▶ Before Use
- ▶ Shooting
- ▶ Viewing
- ▶ **Using MENU items (Shooting)**
- ▶ Using MENU items (Viewing)
- ▶ Changing settings
- ▶ Viewing images on a TV
- ▶ Using with your computer
- ▶ Printing
- ▶ Troubleshooting
- ▶ Precautions / About this camera

[→ Contents list](#)

In-Camera Guide

This camera contains an internal function guide. This allows you to search the camera's functions according to your needs.

You can use the selected function after reading the guide.

1. Press the MENU button.
2. Select the desired MENU item using ▲ / ▼ on the control button.
3. Press the ?/☰ (In-Camera Guide) button.
The operation guide for the selected function in step 2 is displayed.
4. Use ▲ / ▼ to switch the display from summary to operation to details.
 - When you select [Use this function], the camera switches to the selected mode automatically.
 - You can search for a function by key word(s) or icon, by pressing the ?/☰ (In-Camera Guide) button when MENU is not displayed.
5. To end [In-Camera Guide], press the ?/☰ (In-Camera Guide) button.

[▲ Back to top](#)

[Top page](#) > [Using MENU items \(Shooting\)](#) > [Shooting MENU list](#) > [MENU items not available in some REC modes](#)





- ▶ Before Use
- ▶ Shooting
- ▶ Viewing
- ▶ Using MENU items (Shooting)
- ▶ Using MENU items (Viewing)
- ▶ Changing settings
- ▶ Viewing images on a TV
- ▶ Using with your computer
- ▶ Printing
- ▶ Troubleshooting
- ▶ Precautions / About this camera

[→ Contents list](#)

MENU items not available in some REC modes

































▼ MENU items not available in Scene Selection / Picture Effect mode

In the table below, check mark indicates settings that can be changed, while – indicates settings that cannot be changed. A setting may be fixed or restricted depending on the shooting mode. For details, see each topic.

Menu items		P	M		
Scene Selection	–	–	–	–	–
Easy Mode	✓	–	–	–	–
Still Image Size	✓	✓	✓	–	–
Panorama Image Size	–	–	–	✓	–
Movie Size	–	–	–	–	✓
Cont. Shooting Settings	✓	✓	✓	–	–
Bracket Setting	–	✓	✓	–	–
EV	✓	✓	–	✓	✓
ISO	–	✓	✓	–	–
White Balance	–	✓	✓	✓	✓
Focus	–	✓	✓	✓	–
Metering Mode	–	✓	✓	✓	–
Scene Recognition	✓	–	–	–	–
Soft Skin Effect	–	–	–	–	–
Smile Detection Sensitivity	✓	✓	✓	–	–
Face Detection	✓	✓	✓	–	–
DRO	–	✓	✓	–	–
Anti Blink	–	–	–	–	–
Movie SteadyShot	–	–	–	–	✓
Picture Effect	–	✓	✓	–	–
Color hue	–	✓	✓	–	–
Extracted Color	–	✓	✓	–	–
In-Camera Guide	✓	✓	✓	✓	✓
 (Settings)	✓	✓	✓	✓	✓



MENU items not available in Scene Selection / Picture Effect mode

The icons below **SCN** or  indicate the available modes.

Menu items	SCN	
Scene Selection	✓	–
Easy Mode	–	–
Still Image Size	✓	✓
Panorama Image Size	–	–
Movie Size	–	–
Cont. Shooting Settings	   	✓
Bracket Setting	   	–
EV	✓	✓
ISO		–
White Balance* ¹	  	–
Focus	–	–
Metering Mode	–	–
Scene Recognition	–	–
Soft Skin Effect* ²	  	–
Smile Detection Sensitivity	     	–
Face Detection* ³	     	✓
DRO	–	–
Anti Blink		–
Movie SteadyShot	–	–
Color hue	–	
Extracted Color	–	
In-Camera Guide	✓	✓
 (Settings)	✓	✓

*¹ [Flash] for [White Balance] cannot be selected when Scene Selection is set to  (High Sensitivity) mode.

*² [Off] for [Soft Skin Effect] cannot be selected when Scene Selection is set to  (Soft Skin) mode.

*³ [Off] for [Face Detection] cannot be selected when Scene Selection is set to  (Soft Skin) or  (Soft Snap) mode.

- ▶ Before Use
- ▶ Shooting
- ▶ Viewing
- ▶ Using MENU items (Shooting)
- ▶ Using MENU items (Viewing)
- ▶ Changing settings
- ▶ Viewing images on a TV
- ▶ Using with your computer
- ▶ Printing
- ▶ Troubleshooting
- ▶ Precautions / About this camera

[→ Contents list](#)

Using MENU items (Viewing)

You can select the various viewing functions easily from the MENU button.

1. Press the  (Playback) button to switch to playback mode.
2. Press the MENU button to display the Menu screen.

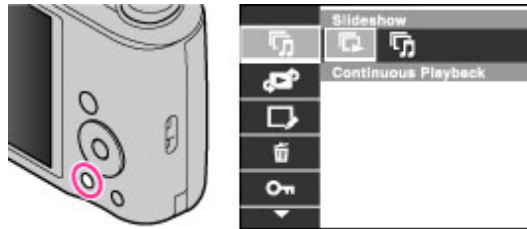

3. Select the desired menu item with  /  /  /  on the control button.

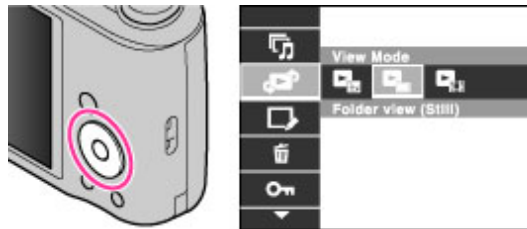

4. Press  on the control button.

[▲ Back to top](#)

- ▶ Before Use
- ▶ Shooting
- ▶ Viewing
- ▶ Using MENU items (Shooting)
- ▶ Using MENU items (Viewing)
- ▶ Changing settings
- ▶ Viewing images on a TV
- ▶ Using with your computer
- ▶ Printing
- ▶ Troubleshooting
- ▶ Precautions / About this camera



[→ Contents list](#)



Slideshow

▼ Continuous Playback

▼ Slideshow with music

Images are automatically played back in succession.

1. Press the  (Playback) button to switch to playback mode.
2. MENU →  (Slideshow) → desired slideshow → ● on the control button

 (Continuous Playback)	Starts playback from the currently displayed image.
 (Slideshow with music)	Plays back still images in succession along with effects and music.

Continuous Playback

1. Select the desired image for playing with the control button.
2. MENU →  (Slideshow) → [Continuous Playback] → ●

Control button	Action
●	Stop
▲	Sets the display settings.
▼	Displays the volume control screen. ● Adjust the volume with ▲ / ▼ on the control button, then press ●.
◀	Rewinds image.
▶	Forwards image.

Viewing panoramic images during continuous playback

The whole panoramic image is displayed for 3 seconds.

You can scroll a panoramic image by pressing ●.

Slideshow with music

1. MENU →  (Slideshow) → [Slideshow with music] → ● on the control button
Displays the setting screen.
2. Select a desired setting.
3. [Start] → ●
4. Press ● to end the slideshow.

Note

-

- [Slideshow with music] is not available for panorama images.

Playback Selection		
Selects the group of images to be shown. The setting is fixed to [Folder] when the internal memory is used to record images.		
<input checked="" type="checkbox"/>	All	Plays a slideshow of all the images in order.
<input type="checkbox"/>	This Date	Plays a slideshow of images with the currently selected date range when [View Mode] is [Date View].
<input type="checkbox"/>	Folder	Plays a slideshow of images in the currently selected folder in Folder View.

Effects		
Selects the playback speed and mood for slideshows.		
<input checked="" type="checkbox"/>	Simple	A simple slideshow switching images at a preset interval. The playback interval is adjustable in [Interval] and you can thoroughly enjoy your images.
<input type="checkbox"/>	Nostalgic	A moody slideshow reproducing the atmosphere of a movie scene.
<input type="checkbox"/>	Stylish	A stylish slideshow proceeding at a middle tempo.
<input type="checkbox"/>	Active	A high-tempo slideshow suitable for active scene.

Music		
Specifies the music to be played during slideshows. You can select more than one background music track. Press ▼ on the control button to display the volume control screen, then press ▲ / ▼ to adjust the volume.		
<input checked="" type="checkbox"/>	Music1	The default setting for a [Simple] slideshow.
<input type="checkbox"/>	Music2	The default setting for a [Nostalgic] slideshow.
<input type="checkbox"/>	Music3	The default setting for a [Stylish] slideshow.
<input type="checkbox"/>	Music4	The default setting for a [Active] slideshow.
<input type="checkbox"/>	Muting	Does not use BGM.

Note

- The movies are played back without their audio.

Interval		
Sets the screen switching interval. The setting is fixed to [Auto] when [Simple] is not selected as the [Effects].		
<input type="checkbox"/>	1 sec	Sets the display interval of images for a [Simple] slideshow.
<input checked="" type="checkbox"/>	3 sec	
<input type="checkbox"/>	5 sec	
<input type="checkbox"/>	10 sec	
<input type="checkbox"/>	Auto	The interval is set to suit the selected [Effects] item.

 Selecting background music

You can transfer a desired music file from your CDs or MP3 files to the camera to play back during slideshow. To transfer music, install the “Music Transfer” to your computer.

Related Topic

[“Music Transfer”](#)

[▲ Back to top](#)

Copyright 2012 Sony Corporation

- ▶ Before Use
- ▶ Shooting
- ▶ Viewing
- ▶ Using MENU items (Shooting)
- ▶ Using MENU items (Viewing)
- ▶ Changing settings
- ▶ Viewing images on a TV
- ▶ Using with your computer
- ▶ Printing
- ▶ Troubleshooting
- ▶ Precautions / About this camera



[→ Contents list](#)



View Mode

▼ Displaying the Calendar

▼ Viewing images taken with a different camera

Allows you to select the display format for images.





1. Press the  (Playback) button to switch to playback mode.
2. MENU →  (View Mode) → desired mode → ● on the control button

<input checked="" type="checkbox"/>	 (Date View)	Displays images by date.
<input type="checkbox"/>	 (Folder view (Still))	Displays still images.
<input type="checkbox"/>	 (Folder view (Movie))	Displays movies.

Note

- When the internal memory is used to record images, View Mode is set to Folder View and still images and movies are displayed in the same folder.

■ Displaying the Calendar

1. MENU →  (View Mode) → [Date View] → ● on the control button
2. Turn the W/T (zoom) lever to W side () repeatedly until the Calendar is displayed.
Use the control button to select / , then select the month you want to display. Select the date and press ● to view images of the selected date in index mode.

■ Viewing images taken with a different camera

This camera creates an Image Database File on the memory card for recording and playing images. If the camera detects images not registered in the Image Database File on the memory card, a registration screen with the message "Files found which were not recognized Import files" will be displayed. To view unregistered images, register them by selecting [OK].

- Use a sufficiently charged battery to register images. If a battery with a low charge is used to register images, it may not be possible to transfer all of the data or the data may be corrupted if the battery charge runs out.



[▲ Back to top](#)







- ▶ Before Use
- ▶ Shooting
- ▶ Viewing
- ▶ Using MENU items (Shooting)
- ▶ Using MENU items (Viewing)
- ▶ Changing settings
- ▶ Viewing images on a TV
- ▶ Using with your computer
- ▶ Printing
- ▶ Troubleshooting
- ▶ Precautions / About this camera

[→ Contents list](#)

Retouch

Retouches a recorded image and saves it as a new file. The original image is retained.

1. Press the  (Playback) button to switch to playback mode.
2. MENU →  (Retouch) → desired mode → ● on the control button
3. Perform retouching according to the operation method in each mode.

 (Trimming (Resize))	<p>Records the zoomed playback image.</p>  <ol style="list-style-type: none"> ① Turn the W/T (zoom) lever to the T () side to zoom in, and to the W side to zoom out. ② Set the zoom point with the control button. ③ MENU → select an image size to save → ● ④ [OK] → ● <ul style="list-style-type: none"> ● The quality of trimmed images may deteriorate. ● The image size that you can trim may vary depending on the image.
 (Red Eye Correction)	<p>Corrects the red-eye phenomenon caused by flash.</p>  <p>Select [OK] with the control button → ● .</p> <ul style="list-style-type: none"> ● You may not be able to correct the red-eye phenomenon depending on the image.
 (Unsharp masking)	<p>Sharpens the image within a chosen frame.</p>

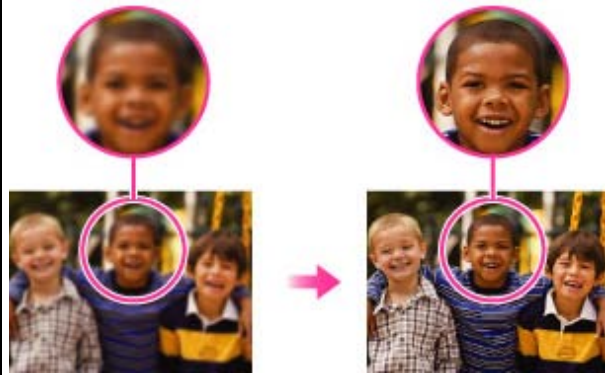

- ① Select the area (frame) of the desired image to retouch with the control button → MENU.
- ② [OK] → ●
 - Depending on the image, sufficient correction may not be applied and the image quality may deteriorate.

Note

- You cannot retouch the panorama images or movies.

[▲ Back to top](#)

Copyright 2012 Sony Corporation



- ▶ Before Use
- ▶ Shooting
- ▶ Viewing
- ▶ Using MENU items (Shooting)
- ▶ Using MENU items (Viewing)
- ▶ Changing settings
- ▶ Viewing images on a TV
- ▶ Using with your computer
- ▶ Printing
- ▶ Troubleshooting
- ▶ Precautions / About this camera





[→ Contents list](#)

Delete

Allows you to select unwanted images for deletion.

You can also delete images using the  (Delete) button. [\[Details\]](#)

1. Press the  (Playback) button to switch to playback mode.
2. MENU →  (Delete) → desired mode → ● on the control button
3. [OK] → ●

 (This Image)	Deletes the currently displayed image in single-image mode.
 (Multiple Images)	<p>You can select and delete multiple images. Do as the following after step 2.</p> <p>① Select an image then press ● . Repeat the above steps until there are no more images to be deleted. Select an image with a ✓ mark to release the ✓ mark.</p> <p>② MENU → [OK] → ●</p>
 (All Images on This Date)  (All in This Folder)	Deletes all images in the selected date range or folder at once.

Notes

- In Easy Mode, you can select from [1 image] or [All].
- When the internal memory is used to record images, View Mode is set to Folder View and still images and movies are displayed in the same folder.

Related Topic

[Delete button](#)

[▲ Back to top](#)

- ▶ Before Use
- ▶ Shooting
- ▶ Viewing
- ▶ Using MENU items (Shooting)
- ▶ Using MENU items (Viewing)
- ▶ Changing settings
- ▶ Viewing images on a TV
- ▶ Using with your computer
- ▶ Printing
- ▶ Troubleshooting
- ▶ Precautions / About this camera



[→ Contents list](#)







Protect

▼ To cancel the protection

Protects recorded images against accidental erasure.

The  mark is displayed for registered images.

1. Press the  (Playback) button to switch to playback mode.
2. MENU →  (Protect) → desired mode →  on the control button

 (This Image)	Protects the currently displayed image in single-image mode.
 (Multiple Images)	<p>You can select and protect multiple images. Do as the following after step 2.</p> <p>① Select an image then press  . Repeat the above steps until there are no more images to be protected. Select an image with a  mark to release the  mark.</p> <p>② MENU → [OK] → </p>

Note

- When the internal memory is used to record images, View Mode is set to Folder View and still images and movies are displayed in the same folder.

▮ To cancel the protection

Select the image for which you want to cancel protection, and unlock it by pressing  on the control button as the same procedure to protect it.

The  indicator disappears, and the protection is released.

[▲ Back to top](#)

- ▶ Before Use
- ▶ Shooting
- ▶ Viewing
- ▶ Using MENU items (Shooting)
- ▶ Using MENU items (Viewing)
- ▶ Changing settings
- ▶ Viewing images on a TV
- ▶ Using with your computer
- ▶ Printing
- ▶ Troubleshooting
- ▶ Precautions / About this camera

[→ Contents list](#)



Print (DPOF)

▼ Clearing the DPOF mark

DPOF (Digital Print Order Format) is a function that allows you to specify the images of the memory card that you want to print out later.

The **DPOF** (Print order) mark is displayed for registered images.

1. Press the  (Playback) button to switch to playback mode.
2. MENU → **DPOF** → desired mode → ● on the control button

 (This Image)	Orders printing the currently displayed image in single-image mode.
 (Multiple Images)	<p>You can select and order printing multiple images. Do as the following, after step 2.</p> <p>① Select an image then press ● . Repeat the above steps until there are no more images to be printed. Select an image with a ✓ mark to release the ✓ mark.</p> <p>② MENU → [OK] → ●</p>

Notes

- The **DPOF** (Print order) mark cannot be added to the following images:
 - Movies
 - Images in the internal memory
- You can add a **DPOF** (Print order) mark to a maximum 999 images.

Clearing the DPOF mark

Select the image to clear the DPOF registration, then press ● on the control button in the same procedure as when making a **DPOF** mark.

The **DPOF** mark disappears and the DPOF registration is cleared.

Related Topic

[Printing still images](#)



[▲ Back to top](#)

[▶ Before Use](#)[▶ Shooting](#)[▶ Viewing](#)[▶ Using MENU items \(Shooting\)](#)[▶ Using MENU items \(Viewing\)](#)[▶ Changing settings](#)[▶ Viewing images on a TV](#)[▶ Using with your computer](#)[▶ Printing](#)[▶ Troubleshooting](#)[▶ Precautions / About this camera](#)[→ Contents list](#)

Rotate

Rotates a still image. Use this to display a horizontal orientation image in vertical orientation.



1. Press the  (Playback) button to switch to playback mode.
2. MENU →  (Rotate) → ● on the control button
3. Press ● .
The still image will be rotated counter-clockwise. If you want to rotate the image again, repeat step 3.

Notes

- You cannot rotate the following images:
 - Movies
 - Protected still images
- You may not be able to rotate images shot with other cameras.
- When viewing images on a computer, the image rotation information may not be reflected depending on the software.

[▲ Back to top](#)

- ▶ Before Use
- ▶ Shooting
- ▶ Viewing
- ▶ Using MENU items (Shooting)
- ▶ Using MENU items (Viewing)
- ▶ Changing settings
- ▶ Viewing images on a TV
- ▶ Using with your computer
- ▶ Printing
- ▶ Troubleshooting
- ▶ Precautions / About this camera

[→ Contents list](#)

In-Camera Guide

This camera contains an internal function guide. This allows you to search the camera's functions according to your needs.

You can use the selected function after reading the guide.

1. Press the MENU button.
2. Select the desired MENU item using ▲ / ▼ on the control button.
3. Press the ?/☒ (In-Camera Guide) button.
The operation guide for the selected function in step 2 is displayed.
4. Use ▲ / ▼ to switch the display from summary to operation to details.
 - When you select [Use this function], the camera switches to the selected mode automatically.
 - You can search for a function by key word(s) or icon, by pressing the ?/☒ (In-Camera Guide) button when MENU is not displayed.
5. To end [In-Camera Guide], press the ?/☒ (In-Camera Guide) button.

[▲ Back to top](#)











[Top page](#) > [Using MENU items \(Viewing\)](#) > [Playback MENU list](#) > [MENU items that cannot be set according to View Mode](#)

- ▶ Before Use
- ▶ Shooting
- ▶ Viewing
- ▶ Using MENU items (Shooting)
- ▶ Using MENU items (Viewing)
- ▶ Changing settings
- ▶ Viewing images on a TV
- ▶ Using with your computer
- ▶ Printing
- ▶ Troubleshooting
- ▶ Precautions / About this camera

[→ Contents list](#)

MENU items that cannot be set according to View Mode

In the table below, check mark indicates a user-changeable function, while — indicates an unchangeable one.

Menu items	Memory card			Internal Memory
	 Date View	 Folder view (Still)	 Folder view (Movie)	Folder View
 (Slideshow)	✓	✓	✓	✓
 (View Mode)	✓	✓	✓	—
 (Retouch)	✓	✓	—	✓
 (Delete)	✓	✓	✓	✓
 (Protect)	✓	✓	✓	✓
Print (DPOF)	✓	✓	—	—
 (Rotate)	✓	✓	—	✓
 (In-Camera Guide)	✓	✓	✓	✓
 (Settings)	✓	✓	✓	✓

Note

- Only the items that are available for each mode are displayed on the screen.

[▲ Back to top](#)

- ▶ Before Use
- ▶ Shooting
- ▶ Viewing
- ▶ Using MENU items (Shooting)
- ▶ Using MENU items (Viewing)
- ▶ Changing settings
- ▶ Viewing images on a TV
- ▶ Using with your computer
- ▶ Printing
- ▶ Troubleshooting
- ▶ Precautions / About this camera



[→ Contents list](#)

Changing camera settings

You can change the settings on the [Settings] screen.

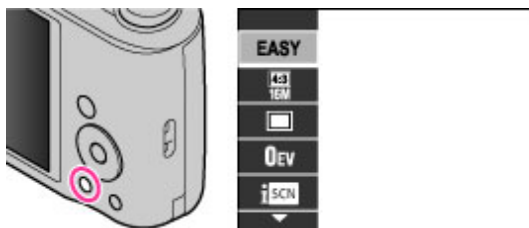
1. Press the MENU button to display the Menu screen.



2. Select  (Settings) with  on the control button, then press  to display the setup screen.

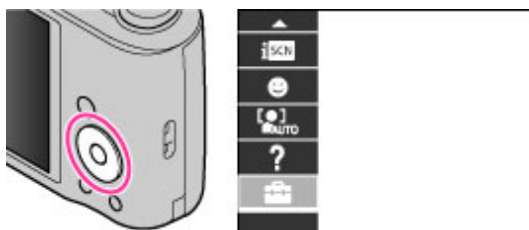

3. Select the desired category using  /  /  / , then press  to display the setup screen.

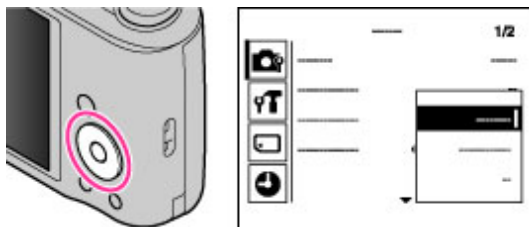

4. Select the desired setting, then press .

Notes

- [Shooting Settings] appears only when settings have been entered from shooting mode.
- [Memory Card Tool] appears only when a memory card is inserted in the camera, while [Internal Memory Tool] appears only when a memory card is not inserted.

[▲ Back to top](#)

- ▶ Before Use
- ▶ Shooting
- ▶ Viewing
- ▶ Using MENU items (Shooting)
- ▶ Using MENU items (Viewing)
- ▶ Changing settings
- ▶ Viewing images on a TV
- ▶ Using with your computer
- ▶ Printing
- ▶ Troubleshooting
- ▶ Precautions / About this camera

[→ Contents list](#)

AF Illuminator





The AF illuminator supplies fill light to focus more easily on a subject in dark surroundings. The AF illuminator emits red light allowing the camera to focus easily when the shutter button is pressed halfway, until the focus is locked. The **AF-ON** indicator appears at this time.

1. Set the camera to shooting mode.
2. MENU →  (Settings) →  (Shooting Settings) → [AF Illuminator] → desired mode →



<input checked="" type="checkbox"/>	Auto	Uses / Does not use the AF illuminator.
<input type="checkbox"/>	Off	

Notes

- Focus is achieved as long as the AF illuminator light reaches the subject, regardless of whether light fails to reach the center of the subject.
- You cannot use the AF illuminator in the following situations:
 - In Movie Mode
 - In Sweep Panorama mode
 - When  (Landscape),  (Night Scene),  (Pet) or  (Fireworks) mode is selected in Scene Selection.
 - When [Self-Timer] is set to [Self-portrait One Person] or [Self-portrait Two People].
- When you use the AF illuminator, the normal AF range finder frame is disabled and a new AF range finder frame is displayed by a dotted line. AF operates with priority on subjects located near the center of the frame.
- The AF illuminator emits very bright light. Although there is no health hazard, do not look directly into the AF illuminator emitter at close range.

[▲ Back to top](#)

[▶ Before Use](#)[▶ Shooting](#)[▶ Viewing](#)[▶ Using MENU items \(Shooting\)](#)[▶ Using MENU items \(Viewing\)](#)[▶ Changing settings](#)[▶ Viewing images on a TV](#)[▶ Using with your computer](#)[▶ Printing](#)[▶ Troubleshooting](#)[▶ Precautions / About this camera](#)[→ Contents list](#)

Grid Line

With reference to the grid lines, you can easily set a subject in a horizontal/vertical position.

1. Set the camera to shooting mode.
2. MENU →  (Settings) →  (Shooting Settings) → [Grid Line] → desired mode → ●

	On	Select to display or not display grid lines.
<input checked="" type="checkbox"/>	Off	

[▲ Back to top](#)

[▶ Before Use](#)[▶ Shooting](#)[▶ Viewing](#)[▶ Using MENU items \(Shooting\)](#)[▶ Using MENU items \(Viewing\)](#)[▶ Changing settings](#)[▶ Viewing images on a TV](#)[▶ Using with your computer](#)[▶ Printing](#)[▶ Troubleshooting](#)[▶ Precautions / About this camera](#)[→ Contents list](#)

Disp. Resolution

Selects the display quality on the screen for shooting.

1. Set the camera to shooting mode.
2. MENU →  (Settings) →  (Shooting Settings) → [Disp. Resolution] → desired mode →



<input checked="" type="checkbox"/>	High	Displays a high-quality image for shooting.
<input type="checkbox"/>	Standard	Displays a standard-quality image for shooting.

Notes

- The battery power may decrease faster when [Disp. Resolution] is set to [High].
- In Sweep Panorama and Movie Mode, [Disp. Resolution] is set to [High].

[▲ Back to top](#)

- ▶ Before Use
- ▶ Shooting
- ▶ Viewing
- ▶ Using MENU items (Shooting)
- ▶ Using MENU items (Viewing)
- ▶ Changing settings
- ▶ Viewing images on a TV
- ▶ Using with your computer
- ▶ Printing
- ▶ Troubleshooting
- ▶ Precautions / About this camera

[→ Contents list](#)

Digital Zoom

▼ Total zoom scale when using Smart zoom (including optical zoom 16×)

Selects the digital zoom mode. The camera enlarges the image using optical zoom (up to 16×). When the zoom scale is exceeded, the camera uses either smart or precision digital zoom.

1. Set the camera to shooting mode.
2. MENU →  (Settings) →  (Shooting Settings) → [Digital Zoom] → desired mode → ●

<input checked="" type="checkbox"/>	Smart (SQ)	Enlarges the image digitally within the range where the image will not be distorted, according to the image size (Smart zoom).
<input type="checkbox"/>	Precision (PQ)	Enlarges all image sizes by the total zoom scale of approximately 64×, including the optical zoom 16×. However, note that the image quality deteriorates when the optical zoom scale is exceeded (Precision digital zoom).
<input type="checkbox"/>	Off	Does not use the digital zoom.

Notes

- The Digital Zoom function does not operate in the following situations:
 - In Sweep Panorama mode
 - When Scene Selection is set to  (Advanced Sports Shooting).
 - When the Smile Shutter function is activated.
 - When [Self-Timer] is set to [Self-portrait One Person] or [Self-portrait Two People].
- The smart zoom is not available when you record movies or the image size is set to [16M] or [16:9(12M)].
- The Face Detection function does not work when using the digital zoom.

■ Total zoom scale when using Smart zoom (including optical zoom 16×)

The supported zoom ratio differs depending on the image size.

Size	Total zoom scale
10M	Approx. 20×
5M	Approx. 28×
VGA	Approx. 115×
16:9(2M)	Approx. 38×



[▲ Back to top](#)

- ▶ Before Use
- ▶ Shooting
- ▶ Viewing
- ▶ Using MENU items (Shooting)
- ▶ Using MENU items (Viewing)
- ▶ Changing settings
- ▶ Viewing images on a TV
- ▶ Using with your computer
- ▶ Printing
- ▶ Troubleshooting
- ▶ Precautions / About this camera

[→ Contents list](#)

Red Eye Reduction

The flash strobos two or more times before shooting to reduce the red-eye phenomenon when using the flash.

1. Set the camera to shooting mode.
2. MENU →  (Settings) →  (Shooting Settings) → [Red Eye Reduction] → desired mode
→ ●

<input checked="" type="checkbox"/>	Auto	When the Face Detection function is activated, the flash strobos automatically to reduce the red-eye phenomenon.
<input type="checkbox"/>	On	The flash always strobos to reduce the red-eye phenomenon.
<input type="checkbox"/>	Off	Does not use Red Eye Reduction.

What causes the red-eye phenomenon?



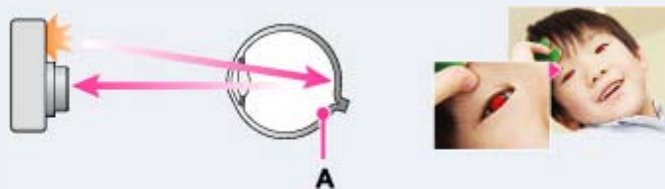

Pupils become dilated in dark environments. Flash light is reflected off the blood vessels at the back of the eye (retina) (A), causing the “red-eye” phenomenon.



Other ways to reduce red-eye

- Select **ISO** (High Sensitivity) mode in Scene Selection. (The flash is set to [Off] automatically.)
- When the eyes of the subject turn out red, correct the image with [Retouch] → [Red Eye Correction] on the viewing menu or with the software “PlayMemories Home”.

Notes

- To avoid blurring of images, hold the camera firmly until the shutter is released. It usually takes a second until the shutter is released, and also be sure not to allow the subject to move during this period.
- Red Eye Reduction may not produce the desired effects. It depends on individual differences and conditions, such as distance to the subject, or if the subject looked away from the pre-strobe.
- If you do not use the Face Detection function, Red Eye Reduction does not work, even when you select [Auto].
- [Red Eye Reduction] is set to [Off] in the following situations:
 - When  (Night Scene), **ISO** (High Sensitivity),  (Gourmet),  (Pet),  (Fireworks) or  (Advanced Sports Shooting) mode is selected in Scene Selection.
 - When Smile Shutter function is activated.

[▲ Back to top](#)

- ▶ Before Use
- ▶ Shooting
- ▶ Viewing
- ▶ Using MENU items (Shooting)
- ▶ Using MENU items (Viewing)
- ▶ Changing settings
- ▶ Viewing images on a TV
- ▶ Using with your computer
- ▶ Printing
- ▶ Troubleshooting
- ▶ Precautions / About this camera

[→ Contents list](#)

Blink Alert

When an image with the subject's eyes closed is recorded while Face Detection is activated, the message "Blinked eye detected" is displayed.

1. Set the camera to shooting mode.
2. MENU →  (Settings) →  (Shooting Settings) → [Blink Alert] → desired mode → ●

<input checked="" type="checkbox"/>	Auto	Displays / hides the "Blinked eye detected" message.
<input type="checkbox"/>	Off	

[▲ Back to top](#)

- ▶ Before Use
- ▶ Shooting
- ▶ Viewing
- ▶ Using MENU items (Shooting)
- ▶ Using MENU items (Viewing)
- ▶ Changing settings
- ▶ Viewing images on a TV
- ▶ Using with your computer
- ▶ Printing
- ▶ Troubleshooting
- ▶ Precautions / About this camera



[→ Contents list](#)

Write Date

Sets whether to record a shooting date on the still image.



1. Set the camera to shooting mode.
2. MENU →  (Settings) →  (Shooting Settings) → [Write Date] → desired mode → ●

On ()	Records a shooting date. When [On] is selected, the  mark will appear on the bottom right of the screen while shooting. However, in some shooting modes that cannot record dates on images, the  mark will disappear.
<input checked="" type="checkbox"/> Off	Does not record a shooting date.

Notes

- You cannot record dates in the following situations:
 - In Movie Mode
 - In Sweep Panorama mode
 - In Cont. Shooting Settings mode
 - In Easy Mode
- If you shot images with the date once, you cannot delete the date from the images later.
- The dates are doubly printed, if you set the camera to superimpose the dates when printing.
- The recorded time of the image cannot be superimposed on the image.

[▲ Back to top](#)

[▶ Before Use](#)[▶ Shooting](#)[▶ Viewing](#)[▶ Using MENU items \(Shooting\)](#)[▶ Using MENU items \(Viewing\)](#)[▶ Changing settings](#)[▶ Viewing images on a TV](#)[▶ Using with your computer](#)[▶ Printing](#)[▶ Troubleshooting](#)[▶ Precautions / About this camera](#)[→ Contents list](#)

Beep

Selects the sound produced when you operate the camera.

1. MENU →  (Settings) →  (Main Settings) → [Beep] → desired mode → ●

	Shutter	Turns on the shutter sound when you press the shutter button.
<input checked="" type="checkbox"/>	On	Turns on the beep/shutter sound when you press the control/shutter button.
<input type="checkbox"/>	Off	Turns off the beep/shutter sound.



[▲ Back to top](#)

[▶ Before Use](#)[▶ Shooting](#)[▶ Viewing](#)[▶ Using MENU items \(Shooting\)](#)[▶ Using MENU items \(Viewing\)](#)[▶ Changing settings](#)[▶ Viewing images on a TV](#)[▶ Using with your computer](#)[▶ Printing](#)[▶ Troubleshooting](#)[▶ Precautions / About this camera](#)[→ Contents list](#)

Panel Brightness

You can select the screen brightness from levels 1 to 5. The screen becomes brighter as the number rises.

When you use the camera in bright outside light, select a higher number to see the screen easier.

1. MENU →  (Settings) →  (Main Settings) → [Panel Brightness] → desired mode → ●

Notes



- The brighter the screen, the faster the battery power may decrease.
- The screen grows dark if you do not operate the camera while the power is on.
- When the high-temperature indicator () is displayed, the screen may grow dark regardless of the settings. [\[Details\]](#)

[▲ Back to top](#)

[▶ Before Use](#)[▶ Shooting](#)[▶ Viewing](#)[▶ Using MENU items \(Shooting\)](#)[▶ Using MENU items \(Viewing\)](#)[▶ Changing settings](#)[▶ Viewing images on a TV](#)[▶ Using with your computer](#)[▶ Printing](#)[▶ Troubleshooting](#)[▶ Precautions / About this camera](#)[→ Contents list](#)

Language Setting

Selects the language to be used in the menu items, warnings and messages.

1. MENU →  (Settings) →  (Main Settings) → [Language Setting] → desired mode → ●

[▲ Back to top](#)

[▶ Before Use](#)[▶ Shooting](#)[▶ Viewing](#)[▶ Using MENU items \(Shooting\)](#)[▶ Using MENU items \(Viewing\)](#)[▶ Changing settings](#)[▶ Viewing images on a TV](#)[▶ Using with your computer](#)[▶ Printing](#)[▶ Troubleshooting](#)[▶ Precautions / About this camera](#)[→ Contents list](#)

Display color

Sets the color of the screen display.

1. MENU →  (Settings) →  (Main Settings) → [Display color] → desired mode → ●

<input checked="" type="checkbox"/>	Black	Sets the background color of the screen.
<input type="checkbox"/>	White	
<input type="checkbox"/>	Pink	

[▲ Back to top](#)

[▶ Before Use](#)[▶ Shooting](#)[▶ Viewing](#)[▶ Using MENU items \(Shooting\)](#)[▶ Using MENU items \(Viewing\)](#)[▶ Changing settings](#)[▶ Viewing images on a TV](#)[▶ Using with your computer](#)[▶ Printing](#)[▶ Troubleshooting](#)[▶ Precautions / About this camera](#)[→ Contents list](#)

Demo Mode

You can set whether to use a demonstration of Smile Shutter or other functions. When there is no need to view a demonstration, set to [Off].

1. MENU →  (Settings) →  (Main Settings) → [Demo Mode] → desired mode → ●

	Demo Mode1	A demonstration of the shooting functions will be performed.
	Demo Mode2	Automatically starts the Smile Shutter demonstration when no operation is performed for 15 seconds.
	Off	Does not perform a demonstration.

Notes

- Pressing the shutter button during the Smile Shutter demonstration operates the shutter, but no image is recorded.
- During a demonstration, if the number of images saved in the internal memory increases, the camera may automatically delete the images.



[▲ Back to top](#)

- ▶ Before Use
- ▶ Shooting
- ▶ Viewing
- ▶ Using MENU items (Shooting)
- ▶ Using MENU items (Viewing)
- ▶ Changing settings
- ▶ Viewing images on a TV
- ▶ Using with your computer
- ▶ Printing
- ▶ Troubleshooting
- ▶ Precautions / About this camera

[→ Contents list](#)

Initialize

Initializes the setting to the default setting.
Even if you execute this function, the images are retained.

1. MENU →  (Settings) →  (Main Settings) → [Initialize] → [OK] → ●

Note

- Be sure not to remove the battery pack while initializing.

[▲ Back to top](#)

- ▶ Before Use
- ▶ Shooting
- ▶ Viewing
- ▶ Using MENU items (Shooting)
- ▶ Using MENU items (Viewing)
- ▶ Changing settings
- ▶ Viewing images on a TV
- ▶ Using with your computer
- ▶ Printing
- ▶ Troubleshooting
- ▶ Precautions / About this camera

[→ Contents list](#)

Function Guide

You can select whether or not the function guide is displayed when you operate the camera.

1. MENU →  (Settings) →  (Main Settings) → [Function Guide] → desired mode → ●

<input checked="" type="checkbox"/>	On	Displays / hides the function guide.
<input type="checkbox"/>	Off	



[▲ Back to top](#)

[▶ Before Use](#)[▶ Shooting](#)[▶ Viewing](#)[▶ Using MENU items \(Shooting\)](#)[▶ Using MENU items \(Viewing\)](#)[▶ Changing settings](#)[▶ Viewing images on a TV](#)[▶ Using with your computer](#)[▶ Printing](#)[▶ Troubleshooting](#)[▶ Precautions / About this camera](#)[→ Contents list](#)

Video Out

Sets the video signal output according to the TV color system of the connected video equipment. The TV color systems differ depending on the country and region.

To view images on a TV screen, check the TV color system of the country or region of use. [\[Details\]](#)

1. MENU →  (Settings) →  (Main Settings) → [Video Out] → desired mode → ●

NTSC	Sets the video output signal to NTSC mode (e.g., for the USA, Japan).
PAL	Sets the video output signal to PAL mode (e.g., for Europe, China).

[▲ Back to top](#)

- ▶ Before Use
- ▶ Shooting
- ▶ Viewing
- ▶ Using MENU items (Shooting)
- ▶ Using MENU items (Viewing)
- ▶ Changing settings
- ▶ Viewing images on a TV
- ▶ Using with your computer
- ▶ Printing
- ▶ Troubleshooting
- ▶ Precautions / About this camera

[→ Contents list](#)

Eco Mode

Sets the length of time until the screen goes dark and the time until the camera turns off.

If you do not operate the camera for a certain period of time while the power is on using the battery pack, the screen goes dark and the camera later turns off automatically to prevent wearing down the battery pack (Auto power-off function).

1. MENU →  (Settings) →  (Main Settings) → [Eco Mode] → desired mode → ●

	Max	Saves battery power better than when set to [Standard]. If the camera is not operated for a certain period of time, the power turns off automatically. In shooting mode, the screen automatically goes dark before the power turns off.
	Standard	If the camera is not operated for a certain period of time, the power turns off automatically. In shooting mode, the screen automatically goes dark before the power turns off. It takes longer before the power turns off than when set to [Max].
	Off	Does not use the Auto power-off function.

Note

- The camera does not turn off automatically in the following situations:
 - During slideshow
 - During playing back movies
 - During Eye-Fi connection



[▲ Back to top](#)

- ▶ Before Use
- ▶ Shooting
- ▶ Viewing
- ▶ Using MENU items (Shooting)
- ▶ Using MENU items (Viewing)
- ▶ Changing settings
- ▶ Viewing images on a TV
- ▶ Using with your computer
- ▶ Printing
- ▶ Troubleshooting
- ▶ Precautions / About this camera

[→ Contents list](#)

USB Connect Setting

Selects the USB mode when connecting the camera to a computer or a USB device using the dedicated USB cable (supplied).

1. MENU →  (Settings) →  (Main Settings) → [USB Connect Setting] → desired mode →



<input checked="" type="checkbox"/>	Mass Storage	Establishes a Mass Storage connection between the camera and a computer or other USB device.
<input type="checkbox"/>	PTP/MTP	When you connect the camera to a computer, the AutoPlay Wizard appears, and the still images in the recording folder on the camera are imported to the computer. (with Windows 7/Vista/XP, Mac OS X)

Note

- When [USB Connect Setting] is set to [PTP/MTP], you cannot export movies to a computer. To export movies to a computer, set [USB Connect Setting] to [Mass Storage].

[▲ Back to top](#)

- ▶ Before Use
- ▶ Shooting
- ▶ Viewing
- ▶ Using MENU items (Shooting)
- ▶ Using MENU items (Viewing)
- ▶ Changing settings
- ▶ Viewing images on a TV
- ▶ Using with your computer
- ▶ Printing
- ▶ Troubleshooting
- ▶ Precautions / About this camera

[➔ Contents list](#)

LUN Setting

Sets the display method for the recording media displayed on a computer screen or other monitor when the camera is connected with a computer or AV component using a USB connection.

1. MENU →  (Settings) →  (Main Settings) → [LUN Setting] → desired mode → ●

<input checked="" type="checkbox"/>	Multi	The images both on the memory card and in the internal memory are displayed. Select this setting when you connect the camera to a computer.
<input type="checkbox"/>	Single	When the memory card is inserted into the camera, the images on the memory card are displayed; when it is not inserted, the images in the internal memory are displayed. Select this setting in cases where the images of both the memory card and the internal memory are not displayed when the camera is connected to a device other than a computer.

Note



- Set [LUN Setting] to [Multi] when installing “PlayMemories Home”.

[▲ Back to top](#)

[▶ Before Use](#)[▶ Shooting](#)[▶ Viewing](#)[▶ Using MENU items \(Shooting\)](#)[▶ Using MENU items \(Viewing\)](#)[▶ Changing settings](#)[▶ Viewing images on a TV](#)[▶ Using with your computer](#)[▶ Printing](#)[▶ Troubleshooting](#)[▶ Precautions / About this camera](#)[→ Contents list](#)

Download Music

You can use “Music Transfer” to change background music tracks.

1. MENU →  (Settings) →  (Main Settings) → [Download Music] → ●

The message “Connect to PC” is displayed.

2. Make a USB connection between the camera and a computer, then start “Music Transfer”.
3. Follow the instructions on the screen to change music files.

[▲ Back to top](#)

- ▶ Before Use
- ▶ Shooting
- ▶ Viewing
- ▶ Using MENU items (Shooting)
- ▶ Using MENU items (Viewing)
- ▶ Changing settings
- ▶ Viewing images on a TV
- ▶ Using with your computer
- ▶ Printing
- ▶ Troubleshooting
- ▶ Precautions / About this camera

[→ Contents list](#)

Empty Music

You can delete all the background music files stored in the camera. It can be used in cases such as when the background music files are damaged and cannot be played.

1. MENU →  (Settings) →  (Main Settings) → [Empty Music] → [OK] → ●

Related Topic

[“Music Transfer”](#)

[▲ Back to top](#)

- ▶ Before Use
- ▶ Shooting
- ▶ Viewing
- ▶ Using MENU items (Shooting)
- ▶ Using MENU items (Viewing)
- ▶ Changing settings
- ▶ Viewing images on a TV
- ▶ Using with your computer
- ▶ Printing
- ▶ Troubleshooting
- ▶ Precautions / About this camera







[→ Contents list](#)

Eye-Fi

▼ Transferring image data using the Eye-Fi card

Sets whether to use the upload function of an Eye-Fi card (commercially available), when you use the Eye-Fi card with this camera. [Eye-Fi] is displayed only when the Eye-Fi card is inserted in the camera.

1. MENU →  (Settings) →  (Main Settings) → [Eye-Fi] → desired mode → ●

	On	<p>Uses the upload function. The Eye-Fi mode display icon on the screen will change depending on the communication mode of the Eye-Fi card.</p> <ul style="list-style-type: none">  Eye-Fi card is in standby mode. There is no image to be sent.  Eye-Fi card is in upload standby mode.  Eye-Fi card is in connecting mode.  Eye-Fi card is uploading images.  An error has occurred.
	Off	Does not use the upload function.



Notes

- As of November 2011, Eye-Fi cards are sold in the U.S.A., Canada, Japan and some countries in the European Union.
- For more information on the Eye-Fi card, contact the manufacturer or seller of Eye-Fi cards directly.
- Eye-Fi cards are permitted only in the countries and regions in which they were purchased. You may be held liable due to local restrictions.
- The Eye-Fi card has a wireless LAN function. Do not insert the Eye-Fi card where wireless LAN is prohibited, such as while aboard an airplane. If the Eye-Fi card is inserted, set [Eye-Fi] to [Off]. When the uploading function of the Eye-Fi card is set to [Off],  OFF is displayed on the screen.

Transferring image data using the Eye-Fi card

1. Set the wireless LAN access point settings or the transferring direction settings of the Eye-Fi card. For details, refer to the operating instructions supplied with the Eye-Fi card.
2. After the settings are finished, insert the Eye-Fi card into the camera, and shoot the images. The recorded images are automatically transferred via the wireless LAN to the PC, etc.



Notes

- When uploading image data, [Eco Mode] is not available.
- If the  (error) icon is displayed, eject and re-insert the Eye-Fi card, or turn the power of the camera off and on again. If the  (error) icon is still displayed, the Eye-Fi card may be corrupted. For details, contact Eye-Fi, Inc.
- Wireless LAN communication may be interrupted by the other communication devices. If data reception is insufficient, move the camera closer to the access point.
- Some Eye-Fi cards have an "Endless Memory Mode." This product does not support "Endless Memory Mode." Make sure that Eye-Fi cards that you insert into this product have "Endless Memory Mode" turned off. For details on setting "Endless Memory Mode", refer to the operating instructions supplied with the Eye-Fi card.

[▶ Before Use](#)[▶ Shooting](#)[▶ Viewing](#)[▶ Using MENU items \(Shooting\)](#)[▶ Using MENU items \(Viewing\)](#)[▶ Changing settings](#)[▶ Viewing images on a TV](#)[▶ Using with your computer](#)[▶ Printing](#)[▶ Troubleshooting](#)[▶ Precautions / About this camera](#)[→ Contents list](#)

Format

Formats the memory card or the internal memory. When you use a memory card with this camera for the first time, it is recommended to format the card using the camera for stable performance of the memory card before shooting. Note that formatting permanently erases all data on the memory card, and is unrecoverable. Save precious data on a computer, etc.

1. MENU →  (Settings) →  (Memory Card Tool) or  (Internal Memory Tool) → [Format] → [OK] → ●

Note

- Note that formatting permanently erases all data including even protected images.

[▲ Back to top](#)

[▶ Before Use](#)[▶ Shooting](#)[▶ Viewing](#)[▶ Using MENU items \(Shooting\)](#)[▶ Using MENU items \(Viewing\)](#)[▶ Changing settings](#)[▶ Viewing images on a TV](#)[▶ Using with your computer](#)[▶ Printing](#)[▶ Troubleshooting](#)[▶ Precautions / About this camera](#)[→ Contents list](#)

Create REC.Folder

Creates a folder in a memory card for recording images.

Images are recorded in the newly created folder until you create another folder or select another recording folder.

1. MENU →  (Settings) →  (Memory Card Tool) → [Create REC.Folder] → [OK] → ●

On the folders

After a new folder is created, you can change the storage destination folder. [\[Details\]](#)

Notes



- This item is not displayed when the internal memory is used to record images.
- When you insert a memory card that was used with other equipment into the camera and shoot images, a new folder may be automatically created.
- Up to 4,000 images can be stored in one folder. When the folder capacity is exceeded, a new folder is automatically created.

[▲ Back to top](#)

[▶ Before Use](#)[▶ Shooting](#)[▶ Viewing](#)[▶ Using MENU items \(Shooting\)](#)[▶ Using MENU items \(Viewing\)](#)[▶ Changing settings](#)[▶ Viewing images on a TV](#)[▶ Using with your computer](#)[▶ Printing](#)[▶ Troubleshooting](#)[▶ Precautions / About this camera](#)[→ Contents list](#)

Change REC.Folder

Changes the folder in the memory card that is currently used for recording images.

1. MENU →  (Settings) →  (Memory Card Tool) → [Change REC.Folder]
2. Select a folder with ◀ / ▶ on the control button.
3. [OK] → ●

Notes



- This item is not displayed when the internal memory is used to record images.
- You cannot select a folder with a number that has only “□ □ □ MSDCF” or “□ □ □ ANV01” as a recording folder.
- You cannot move recorded images to another folder.

[▲ Back to top](#)

[▶ Before Use](#)[▶ Shooting](#)[▶ Viewing](#)[▶ Using MENU items \(Shooting\)](#)[▶ Using MENU items \(Viewing\)](#)[▶ Changing settings](#)[▶ Viewing images on a TV](#)[▶ Using with your computer](#)[▶ Printing](#)[▶ Troubleshooting](#)[▶ Precautions / About this camera](#)[→ Contents list](#)

Delete REC.Folder

Deletes a folder for recording images in a memory card.

1. MENU →  (Settings) →  (Memory Card Tool) → [Delete REC.Folder]
2. Select a folder with ◀ / ▶ on the control button.
3. [OK] → ●

Notes



- This item is not displayed when the internal memory is used to record images.
- If you delete the folder set as the recording folder using [Delete REC.Folder], the folder that has the largest folder number is selected as the next recording folder.
- If a folder contains protected images, images other than protected images are deleted and the folder will remain.
- If a folder contains files that cannot be played back by the camera, you cannot delete a folder.

[▲ Back to top](#)

[▶ Before Use](#)[▶ Shooting](#)[▶ Viewing](#)[▶ Using MENU items \(Shooting\)](#)[▶ Using MENU items \(Viewing\)](#)[▶ Changing settings](#)[▶ Viewing images on a TV](#)[▶ Using with your computer](#)[▶ Printing](#)[▶ Troubleshooting](#)[▶ Precautions / About this camera](#)[→ Contents list](#)

Copy

Copies all images in the internal memory to a memory card.

1. Insert a memory card with sufficient free capacity into the camera.
2. MENU →  (Settings) →  (Memory Card Tool) → [Copy] → [OK] → ●

Notes



- Make sure there is sufficient battery power. Otherwise, the battery power may run out when you attempt to copy image files, causing the copy to fail and possibly corrupt the data.
- Images cannot be copied individually.
- The original images in the internal memory are retained even after copying. To delete the contents of the internal memory, remove the memory card after copying, then format the internal memory ([Format] in [Internal Memory Tool]).
- A new folder is created on the memory card and all the data will be copied to it. You cannot choose a specific folder and copy images to it.

[▲ Back to top](#)

[▶ Before Use](#)[▶ Shooting](#)[▶ Viewing](#)[▶ Using MENU items \(Shooting\)](#)[▶ Using MENU items \(Viewing\)](#)[▶ Changing settings](#)[▶ Viewing images on a TV](#)[▶ Using with your computer](#)[▶ Printing](#)[▶ Troubleshooting](#)[▶ Precautions / About this camera](#)[→ Contents list](#)

File Number

Selects the method used to assign file numbers to images.

1. MENU →  (Settings) →  (Memory Card Tool) → [File Number] → desired mode →



<input checked="" type="checkbox"/>	Series	Assigns numbers to files in sequence even if the recording folder or the memory card is changed. (When the replaced memory card contains a file with a number higher than the last assigned number, a number one higher than the largest number is assigned.)
<input type="checkbox"/>	Reset	Starts from 0001 each time the folder is changed. (When the recording folder contains a file, a number one higher than the largest number is assigned.)

[▲ Back to top](#)

- ▶ Before Use
- ▶ Shooting
- ▶ Viewing
- ▶ Using MENU items (Shooting)
- ▶ Using MENU items (Viewing)
- ▶ Changing settings
- ▶ Viewing images on a TV
- ▶ Using with your computer
- ▶ Printing
- ▶ Troubleshooting
- ▶ Precautions / About this camera

[→ Contents list](#)

Area Setting

Adjusts the time to the local time of a selected area.

1. MENU →  (Settings) →  (Clock Settings) → [Area Setting] → desired setting → ●

<input checked="" type="checkbox"/>	Home	You use the camera in your area. When the currently set area differs from your home area, you must make the Area Setting.
<input type="checkbox"/>	Destination	You use the camera set to the time at your destination. Set the destination area.

Changing Area Setting

Setting a frequently visited destination lets you easily adjust the time when you visit that destination.

1. Select the area part for [Destination], then press ● .



2. Select an area with ◀ / ▶ on the control button, and select Summer Time with ▲ / ▼ .





[▲ Back to top](#)

[▶ Before Use](#)[▶ Shooting](#)[▶ Viewing](#)[▶ Using MENU items \(Shooting\)](#)[▶ Using MENU items \(Viewing\)](#)[▶ Changing settings](#)[▶ Viewing images on a TV](#)[▶ Using with your computer](#)[▶ Printing](#)[▶ Troubleshooting](#)[▶ Precautions / About this camera](#)[→ Contents list](#)

Date & Time Setting

Sets the date and time again.

1. MENU →  (Settings) →  (Clock Settings) → [Date & Time Setting] → desired setting → ●
2. Set the numeric value and desired setting with ▲ / ▼ / ◀ / ▶ on the control button.
3. [OK] → ●

Date & Time Format	You can select the date and time display format.
Summer Time	You can select Summer Time [On]/[Off].
Date & Time	You can set the date and time.

[▲ Back to top](#)

- ▶ Before Use
- ▶ Shooting
- ▶ Viewing
- ▶ Using MENU items (Shooting)
- ▶ Using MENU items (Viewing)
- ▶ Changing settings
- ▶ Viewing images on a TV
- ▶ Using with your computer
- ▶ Printing
- ▶ Troubleshooting
- ▶ Precautions / About this camera

[→ Contents list](#)

[Top page](#) > [Viewing images on a TV](#) > [Viewing an image on a Standard Definition \(SD\) TV](#) > [Viewing an image on a Standard Definition \(SD\) TV](#)

Viewing an image on a Standard Definition (SD) TV

You can view images recorded on the camera in standard picture quality by connecting the camera to a Standard Definition (SD) TV. Refer also to the operating instructions supplied with the TV.

1. Turn off both the camera and the TV.
2. Connect the USB / A/V OUT jack (A) and the audio/video input jacks on the TV (B) using the dedicated A/V cable VMC-15CSR1 (sold separately) (C).

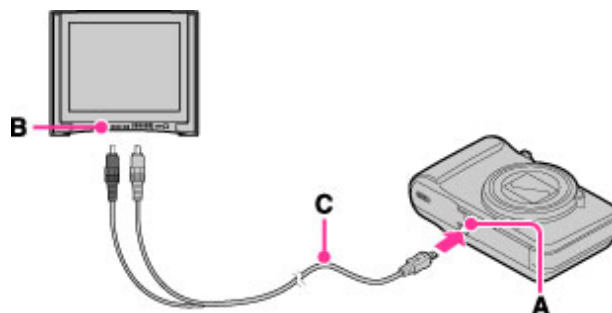

3. Turn on the TV and set the input.
4. Press  (Playback) button to turn on the camera.
Images shot with the camera appear on the TV. Select the desired image with the control button.

Note

- When using the camera abroad, it may be necessary to switch [Video Out]. [\[Details\]](#)

[▲ Back to top](#)

[Top page](#) > [Using with your computer](#) > [Recommended computer environment](#) > [Recommended computer environment](#)

▶ Before Use
▶ Shooting
▶ Viewing
▶ Using MENU items (Shooting)
▶ Using MENU items (Viewing)
▶ Changing settings
▶ Viewing images on a TV
▶ Using with your computer
▶ Printing
▶ Troubleshooting
▶ Precautions / About this camera

[→ Contents list](#)

Recommended computer environment

The following computer environment is recommended when using the software “PlayMemories Home” (Windows), “Music Transfer” (Windows/Mac) and when importing images via a USB connection.

Windows

OS (pre-installed)	Microsoft Windows XP* ¹ SP3/Windows Vista* ² SP2/Windows 7 SP1
CPU	Intel Pentium III 800 MHz or faster (For playing/editing the High Definition movies: Intel Core Duo 1.66 GHz or faster/Intel Core 2 Duo 1.66 GHz or faster)
Memory	Windows XP 512MB or more (1GB or more is recommended.) Windows Vista/Windows 7 1GB or more
Hard Disk (Disk space required for installation)	Approximately 500 MB
Display	1,024 × 768 dots or more

*¹ 64-bit editions and Starter (Edition) are not supported.

*² Starter (Edition) is not supported.

Mac

OS (pre-installed)	USB Connection: Mac OS X v10.3 to v10.7 Music Transfer: Mac OS X v10.4 to v10.7*
--------------------	---

* Equipped with Intel processor

Notes

- Operation is not assured in an environment based on an upgrade of the operating systems described above or in a multi-boot environment.
- If you connect two or more USB devices to a single computer at the same time, some devices, including the camera, may not operate, depending on the types of USB devices you are using.
- Connecting the camera using a USB interface that is compatible with Hi-Speed USB (USB 2.0) allows advanced transfer (high speed transfer), as the camera is compatible with Hi-Speed USB (USB 2.0).
- When your computer resumes activity from suspend or sleep mode, communication between the camera and your computer may not recover at the same time.

[▲ Back to top](#)

- ▶ Before Use
- ▶ Shooting
- ▶ Viewing
- ▶ Using MENU items (Shooting)
- ▶ Using MENU items (Viewing)
- ▶ Changing settings
- ▶ Viewing images on a TV
- ▶ Using with your computer
- ▶ Printing
- ▶ Troubleshooting
- ▶ Precautions / About this camera

[→ Contents list](#)

“PlayMemories Home” (Windows)

Below are examples of the functions available when you use “PlayMemories Home”.

- “PlayMemories Home” allows you to import images shot with the camera to a computer for display. Make a USB connection between the camera and your computer, and click [Import].
- You can display images stored on a computer by shooting date in a calendar display.
- You can save and print images with the date.
- You can correct (Red Eye Correction, etc.) still images, and change the shooting date and time.
- You can upload images to a network service. (An internet connection environment is required.) (Expanded Feature)
- For other details, see [?](#) (PlayMemories Home Help Guide).

Expanded Feature

With “PlayMemories Home (Lite Version)”, the basic functions are available, such as importing the images to a computer and displaying them by shooting date in a calendar display, etc. To take advantage of the various “PlayMemories Home” functions, connect to the Internet and install the “Expanded Feature”.

Note

- Mac does not support “PlayMemories Home”. To play images on a Mac, use the applications installed on your computer.

[▲ Back to top](#)

- ▶ Before Use
- ▶ Shooting
- ▶ Viewing
- ▶ Using MENU items (Shooting)
- ▶ Using MENU items (Viewing)
- ▶ Changing settings
- ▶ Viewing images on a TV
- ▶ Using with your computer
- ▶ Printing
- ▶ Troubleshooting
- ▶ Precautions / About this camera

→ [Contents list](#)

Installing “PlayMemories Home” (Windows)

▼ Starting “PlayMemories Home” (Windows)

▼ Accessing to “PlayMemories Home Help Guide” (Windows)

1. Insert a fully charged battery pack into the camera.
2. Turn on the camera and your computer, and connect the camera to the computer using the dedicated USB cable (supplied) (A).

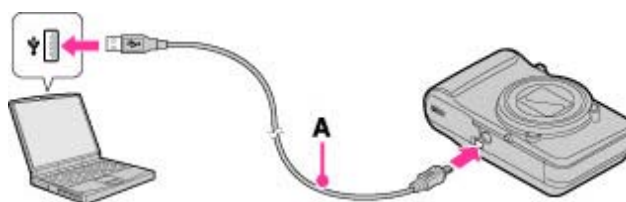

3. [Computer] (in Windows XP, [My Computer]) → [PMHOME] → double-click [PMHOME.EXE].
4. Follow the instructions on the screen to complete the installation.
After the installation is completed, “PlayMemories Home (Lite Version)” will be launched.
 - The installation guide for “Expanded Feature” will be displayed. Continue the installation following the instructions.
 - It is necessary to be connected to the Internet to install the “Expanded Feature”. If you start the program without installing these functions, the installation guide will be displayed if you click on a function that can only be used with the “Expanded Feature”.
 - For details on the “PlayMemories Home”, see [?](#) (PlayMemories Home Help Guide) or the following PlayMemories Home support page (English Only):
<http://www.sony.co.jp/pmh-se/>

Notes

- Log on as Administrator.
- Press MENU → (Settings) → (Main Settings) → [LUN Setting] to [Multi].
- Press MENU → (Settings) → (Main Settings) → [USB Connect Setting] to [Mass Storage].
- It may be necessary to restart your computer. When the restart confirmation message appears, restart the computer following the instructions on the screen.
- DirectX may be installed depending on your computer’s system environment.
- Mac does not support “PlayMemories Home”. To play images on a Mac, use the applications installed on your computer.
- If “PlayMemories Home” has already been installed on your computer, connect the camera with the computer and register your camera to “PlayMemories Home”. The available functions activate.
- If “PMB (Picture Motion Browser)” has already been installed on your computer, “PlayMemories Home” will overwrite it and will be installed. Some functions of “PMB” may become unavailable.

Starting “PlayMemories Home” (Windows)

1. Double-click (PlayMemories Home) on the desktop.
 - To start up “PlayMemories Home” from the Start menu, select [Start] → [All Programs] → (PlayMemories Home).

Accessing to “PlayMemories Home Help Guide” (Windows)

1. Double-click  (PlayMemories Home Help Guide) on the desktop.
 - To start “PlayMemories Home Help Guide” from the Start menu, select [Start] → [All Programs] → [PlayMemories Home] → [PlayMemories Home Help Guide].

[▲ Back to top](#)

Copyright 2012 Sony Corporation

- ▶ Before Use
- ▶ Shooting
- ▶ Viewing
- ▶ Using MENU items (Shooting)
- ▶ Using MENU items (Viewing)
- ▶ Changing settings
- ▶ Viewing images on a TV
- ▶ Using with your computer
- ▶ Printing
- ▶ Troubleshooting
- ▶ Precautions / About this camera

[→ Contents list](#)

“Music Transfer”



“Music Transfer” allows you to replace the Music files provided in the camera at the factory with your favorite tracks, and to delete and add Music files.

You can also restore the tracks stored at the factory to your camera.

Download the software from the following URL and install it on your computer.

Windows: <http://www.sony.co.jp/imsoft/Win/>

Mac: <http://www.sony.co.jp/imsoft/Mac/>

- The following track types can be imported using “Music Transfer”.
 - MP3 files stored on the hard disk of your computer
 - Music CD tracks
 - Preset-music saved on the camera
- Before starting up “Music Transfer” perform MENU →  (Settings) →  (Main Settings) → [Download Music], and connect the camera to the computer.

For other details, see the help in “Music Transfer”.

Related Topic

[Download Music](#)

[Empty Music](#)



[▲ Back to top](#)

[▶ Before Use](#)[▶ Shooting](#)[▶ Viewing](#)[▶ Using MENU items \(Shooting\)](#)[▶ Using MENU items \(Viewing\)](#)[▶ Changing settings](#)[▶ Viewing images on a TV](#)[▶ Using with your computer](#)[▶ Printing](#)[▶ Troubleshooting](#)[▶ Precautions / About this camera](#)[→ Contents list](#)

Software for Mac

For details on software for Macs, access the following URL:

<http://www.sony.co.jp/imsoft/Mac/>

- You can access the above URL by connecting the camera to the Mac computer and clicking [FOR_MAC.URL] in [PMHOME]. Press MENU →  (Settings) →  (Main Settings) → [LUN Setting] to [Multi].

Note

- The available software varies depending on the area.

[▲ Back to top](#)

[Top page](#) > [Using with your computer](#) > [Importing images to a computer](#) > [Connecting the camera to the computer](#)

▶ Before Use

▶ Shooting

▶ Viewing

▶ Using MENU items (Shooting)

▶ Using MENU items (Viewing)

▶ Changing settings

▶ Viewing images on a TV

▶ Using with your computer

▶ Printing

▶ Troubleshooting

▶ Precautions / About this camera

[→ Contents list](#)

Connecting the camera to the computer

1. Insert a sufficiently charged battery pack into the camera, then press the  (Playback) button.
2. Connect the camera to your computer using the dedicated USB cable (supplied) (A).

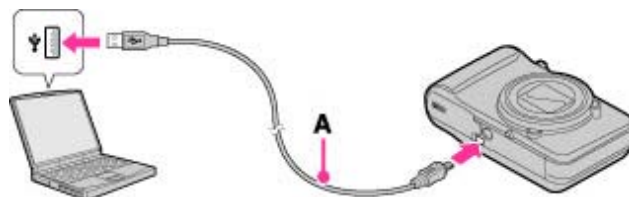

Related Topic

[USB Connect Setting](#)

[LUN Setting](#)

[▲ Back to top](#)

[Top page](#) > [Using with your computer](#) > [Importing images to a computer](#) > [Importing images to a computer](#)

▶ Before Use
▶ Shooting
▶ Viewing
▶ Using MENU items (Shooting)
▶ Using MENU items (Viewing)
▶ Changing settings
▶ Viewing images on a TV
▶ Using with your computer
▶ Printing
▶ Troubleshooting
▶ Precautions / About this camera

[→ Contents list](#)

Importing images to a computer

“PlayMemories Home” allows you to easily import images.

For details on “PlayMemories Home” functions, see the “PlayMemories Home Help Guide”.



Importing images to a Windows computer without using “PlayMemories Home”

When the AutoPlay Wizard appears after making a USB connection between the camera and a computer, click [Open folder to view files] → [OK] → [DCIM] or [MP_ROOT] → copy the desired images to the computer.

Importing images to a Mac computer without using “PlayMemories Home”

Connect the camera to your Mac computer. Double-click the newly recognized icon on the desktop → the folder in which the image you want to import is stored. Then drag and drop the image file on to the hard disk icon.

Note

- Press MENU →  (Settings) →  (Main Settings) → [USB Connect Setting] to [Mass Storage].

[▲ Back to top](#)

[Top page](#) > [Using with your computer](#) > [Importing images to a computer](#) > [Deleting the USB connection](#)

▶ Before Use

▶ Shooting

▶ Viewing

▶ Using MENU items (Shooting)

▶ Using MENU items (Viewing)

▶ Changing settings

▶ Viewing images on a TV

▶ Using with your computer

▶ Printing

▶ Troubleshooting

▶ Precautions / About this camera

[→ Contents list](#)

Deleting the USB connection

Perform the procedures from step 1 to 2 below before:

- Disconnecting the cable.
- Removing a memory card.
- Inserting a memory card into the camera after copying images from the internal memory.
- Turning off the camera.

1. Click the disconnect icon () on the tasktray.



- With Windows 7, click  first, then click .

2. Click [Safely remove USB Mass Storage Device].

Notes

- Drag and drop the icon of the memory card or the drive icon to the “Trash” icon beforehand when you use a Mac computer, and the camera is disconnected from the computer.
- The disconnect icon may not appear when you use a Windows 7 computer. In this case, you can disconnect the camera from the computer without following the above steps.

[▲ Back to top](#)

- ▶ Before Use
- ▶ Shooting
- ▶ Viewing
- ▶ Using MENU items (Shooting)
- ▶ Using MENU items (Viewing)
- ▶ Changing settings
- ▶ Viewing images on a TV
- ▶ Using with your computer
- ▶ Printing
- ▶ Troubleshooting
- ▶ Precautions / About this camera

[→ Contents list](#)

Printing still images

You can print still images using the following methods.

- Printing directly using a printer which supports your memory card type.
For details, see the operating instructions supplied with the printer.
- Printing using a computer
You can import images to a computer using “PlayMemories Home” software and print the images.
For details, see the “PlayMemories Home Help Guide”.
- Printing at a shop
You can take a memory card to a photo printing service shop. As long as the shop supports photo printing services conforming to DPOF, you can make a **DPOF** (Print order) mark on images in advance in the playback mode so that you do not have to reselect them when you print them out at the shop. Before you take image data to a shop, always copy (back up) your data.

Notes

- When you print still images shot in [16:9] mode, both edges may be cut off.
- You cannot print panorama images depending on the printer.

[▲ Back to top](#)

- ▶ Before Use
- ▶ Shooting
- ▶ Viewing
- ▶ Using MENU items (Shooting)
- ▶ Using MENU items (Viewing)
- ▶ Changing settings
- ▶ Viewing images on a TV
- ▶ Using with your computer
- ▶ Printing
- ▶ Troubleshooting
- ▶ Precautions / About this camera

[→ Contents list](#)

If you have problems

If you experience trouble with the camera, try the following solutions.

1. Check the items under “Troubleshooting”, then check your camera.
If a code such as “C/E: □ □ : □ □ ” appears on the screen, see “Self-diagnosis display”.
2. Remove the battery pack, wait for about one minute, re-insert the battery pack, then turn on the power.
3. Initialize the settings. [\[Details\]](#)
4. Consult your Sony dealer or local authorized Sony service facility.
 - Be aware that by sending the camera for repair, you give consent that the contents of the internal memory, music files may be checked.
 - Additional information on this product and answers to frequently asked questions can be found at our Customer Support Website.
<http://www.sony.net/>

[▲ Back to top](#)

- ▶ Before Use
- ▶ Shooting
- ▶ Viewing
- ▶ Using MENU items (Shooting)
- ▶ Using MENU items (Viewing)
- ▶ Changing settings
- ▶ Viewing images on a TV
- ▶ Using with your computer
- ▶ Printing
- ▶ Troubleshooting
- ▶ Precautions / About this camera

[→ Contents list](#)

Battery pack and power

Cannot insert the battery pack into the camera.

- Make sure the direction of the battery pack is correct, and insert it until the battery eject lever is locked.

Cannot turn on the camera.

- After inserting the battery pack into the camera, it may take a few moments for the camera to power up.
- Make sure that the battery pack is inserted correctly.
- The battery discharges gradually by natural discharge even if you do not use. Be sure to charge the battery before using the camera.
- Check that the battery pack type is NP-BG1 (supplied) or NP-FG1 (sold separately).

The power turns off suddenly.

- Depending on the camera and battery temperature, the power may turn off automatically to protect the camera. In this case, a message is displayed on the screen before the power turns off.
- If you do not operate the camera for a certain period of time while the power is on and [Eco Mode] is set to [Standard] or [Max], the camera turns off automatically to prevent wearing down the battery pack. Turn on the camera again.

The remaining charge indicator is incorrect.

- This is caused when you use the camera in an extremely hot or cold location.
- Battery capacity decreases over time and through repeated use. If decreased usage time between charges becomes significant, it is probably time to replace it with a new one.

Cannot charge the battery pack while it is inserted in the camera.

- You cannot charge the battery pack using the AC Adaptor (sold separately). Use the battery charger (supplied) to charge the battery.

The CHARGE lamp flashes while charging the battery.

- Check that the battery pack type is NP-BG1 (supplied) or NP-FG1 (sold separately).
- The CHARGE lamp flashes infrequently when you use a battery pack that has not been used for a long time.
- The CHARGE lamp (on the supplied battery charger) has two flash patterns, fast flash (approx. 0.15-second intervals) and slow flash (approx. 1.5-second intervals). If the lamp flashes quickly, remove the battery pack being charged, and then insert the same battery pack into the battery charger again (until it clicks). If the lamp flashes quickly again, this may indicate a battery pack problem. If the lamp flashes slowly, the charger is in standby mode and charging has temporarily stopped.

Charging stops temporarily and standby mode results when the temperature is outside the range suitable for charging. Charging resumes and the CHARGE lamp lights when the temperature returns to the range suitable for charging.

Charge the battery pack within the proper charging temperature range between 10°C to 30°C (50°F to 86°F).

- For details, see [\[Details\]](#).

The camera emits a sound when shaken.

- When you shake the camera without the power turned on, you may hear a sound. This is not a malfunction.

[▲ Back to top](#)

Copyright 2012 Sony Corporation

- ▶ Before Use
- ▶ Shooting
- ▶ Viewing
- ▶ Using MENU items (Shooting)
- ▶ Using MENU items (Viewing)
- ▶ Changing settings
- ▶ Viewing images on a TV
- ▶ Using with your computer
- ▶ Printing
- ▶ Troubleshooting
- ▶ Precautions / About this camera

[→ Contents list](#)

Shooting still images/movies

Cannot record images.

- If images are recorded on the internal memory even when a memory card is inserted into the camera, make sure that the memory card is fully inserted into the camera.
- Check the free capacity of the internal memory or memory card. If it is full, do one of the following:
 - Delete unnecessary images. [\[Details\]](#) [\[Details\]](#)
 - Change the memory card.
- You cannot record images while charging the flash.
- When recording movies, it is recommended that you use the following memory cards:
 - “Memory Stick PRO Duo” (Mark2) media, “Memory Stick PRO-HG Duo” media
 - SD card, SDHC memory card or SDXC memory card (Class 4 or faster)
- Set [Demo Mode] to [Off]. [\[Details\]](#)

Smile Shutter function does not work.

- No image is shot if a smiling face is not detected. [\[Details\]](#)
- Set [Demo Mode] to [Off]. [\[Details\]](#)





Anti-blur function does not work.

- The anti-blur function may not work properly when shooting night scenes.
- Shoot after pressing the shutter button halfway down.

Recording takes a long time.

- When the shutter speed becomes slower than a certain speed, for example, when you shoot images in dark locations, the camera automatically reduces the image noise. This function is called NR (noise reduction) slow shutter and the shooting time takes longer.

The image is out of focus.

- The subject is too close. When shooting, make sure to position the lens farther away from the subject than the shortest shooting distance (approximately 5 cm (2 inches) (W)/120 cm (3 feet 11 1/4 inches) (T) from the lens).
-  (Night Scene),  (Landscape),  (Fireworks) or  (Advanced Sports Shooting) mode is selected in the Scene Selection when shooting still images.

Zoom does not work.











- You cannot use the optical zoom in Sweep Panorama mode.
- You cannot use the Smart zoom depending on the image size. [\[Details\]](#)
- You cannot use the digital zoom when:

- When  (Advanced Sports Shooting) mode is selected in Scene Selection.
- The Smile Shutter is working.
- [Self-Timer] is set to [Self-portrait One Person] or [Self-portrait Two People].

Cannot select the Face Detection function.

- You can select Face Detection only when the focus mode is set to [Multi AF] and the [Metering Mode] is set to [Multi].





The flash does not work.

- You cannot use the flash when:
 - Cont. Shooting Settings is selected. [\[Details\]](#)
 -  (Night Scene),  (High Sensitivity),  (Fireworks) or  (Advanced Sports Shooting) mode is selected in Scene Selection.
 - Shooting in Sweep Panorama mode.
 - Shooting in Movie Mode.
- Set the flash to  (On) when the Scene Selection mode is set to  (Landscape),  (Gourmet),  (Pet),  (Beach) or  (Snow) mode. [\[Details\]](#)

Fuzzy white circular spots appear in images shot using the flash.

- Particles (dust, pollen, etc.) in the air reflected the flash light and appeared in the image. This is not a malfunction. [\[Details\]](#)

The close-up shoot function (Macro) does not work.

- The camera automatically adjusts the focus. Press and hold the shutter button halfway down. Focus adjustment may take some time when shooting a close subject.
-  (Landscape),  (Night Scene),  (Fireworks) or  (Advanced Sports Shooting) mode is selected in the Scene Selection.

The date and time are not displayed on the screen.

- While shooting, the date and time are not displayed. They are displayed only during playback.

The F value and shutter speed flash when you press and hold the shutter button halfway down.

- The exposure is incorrect. Correct the exposure. [\[Details\]](#)

The image colors are not correct.

- Adjust the White Balance. [\[Details\]](#)

White or purple streaks appear in bright areas of the subject, or the whole screen of the image becomes reddish.

- This phenomenon is called smearing. This is not a malfunction. Smearing is not recorded on still images, but is recorded as streaks or uneven colors on Sweep Panorama images or movies. ("Bright areas" refers to the sun or electric lights which are much brighter than surroundings.)

Noise appears in the image when you view the screen in a dark place.

-

- The camera is attempting to increase the visibility of the screen by temporarily brightening the image under conditions of low illumination. There is no effect on the recorded image.
-

The eyes of the subject come out red.

- Set [Red Eye Reduction] to [Auto] or [On]. [\[Details\]](#)
 - Shoot the subject at a distance closer than the flash range using the flash.
 - Light the room and shoot the subject.
 - Retouch the image using [Retouch] → [Red Eye Correction] in viewing menu [\[Details\]](#), or correct using “PlayMemories Home” [\[Details\]](#).
-

Dots appear and remain on the screen.

- This is not a malfunction. These dots are not recorded.
-

Cannot shoot images in succession.

- The internal memory or memory card is full. Delete unnecessary images. [\[Details\]](#) [\[Details\]](#)
 - The battery level is low. Insert a charged battery pack.
-

The same image is shot several times.

- Set [Cont. Shooting Settings] to [Single Shooting]. [\[Details\]](#)
 - [Scene Recognition] is set to [Advanced]. [\[Details\]](#)
-

[▲ Back to top](#)

Copyright 2012 Sony Corporation

- ▶ Before Use
- ▶ Shooting
- ▶ Viewing
- ▶ Using MENU items (Shooting)
- ▶ Using MENU items (Viewing)
- ▶ Changing settings
- ▶ Viewing images on a TV
- ▶ Using with your computer
- ▶ Printing
- ▶ Troubleshooting
- ▶ Precautions / About this camera

[→ Contents list](#)

Viewing images

Cannot play back images.

- Make sure that the memory card is fully inserted into the camera.
- The folder/file name has been changed on your computer.
- No guarantees are made for playing back, on this camera, files containing images which were processed on a computer or images which were shot using other cameras.
- The camera is in USB mode. Delete the USB connection. [\[Details\]](#)
- Use “PlayMemories Home” to play images stored on a PC with this camera. Use the application handled with Mac for playing back the images on Mac.

The date and time are not displayed.

- The screen display is set to display images only. Press the **DISP** (Display Setting) button to display information. [\[Details\]](#)

Cannot display images in index mode.

- The camera is set to Easy Mode. Cancel Easy Mode.

Cannot hear music during slideshow.

- Transfer music files to the camera with “Music Transfer”. [\[Details\]](#)
- Slideshow is played back with [Continuous Playback]. Select [Slideshow with music] and play back.

The image does not appear on the TV.

- Check [Video Out] to see if the video output signal of the camera is set to the color system of your TV. [\[Details\]](#)
- Check whether the connection is correct. [\[Details\]](#)

[▲ Back to top](#)

- ▶ Before Use
- ▶ Shooting
- ▶ Viewing
- ▶ Using MENU items (Shooting)
- ▶ Using MENU items (Viewing)
- ▶ Changing settings
- ▶ Viewing images on a TV
- ▶ Using with your computer
- ▶ Printing
- ▶ Troubleshooting
- ▶ Precautions / About this camera

[→ Contents list](#)

Computers

Your computer does not recognize the camera.

- When the battery level is low, insert the charged battery pack.
- Set [USB Connect Setting] to [Mass Storage]. [\[Details\]](#)
- Use the dedicated USB cable (supplied).
- Disconnect the dedicated USB cable from both the computer and the camera, and connect it again firmly.
- Disconnect all equipment other than the camera, the keyboard and the mouse from the USB connectors of your computer.
- Connect the camera directly to your computer without passing through a USB hub or other device.

Cannot import images.

- Connect the camera and your computer correctly making a USB connection. [\[Details\]](#)
- When you shoot images with a memory card formatted by a computer, you may not be able to import the images to a computer. Shoot using a memory card formatted by the camera. [\[Details\]](#)

After making a USB connection, "PlayMemories Home" does not start automatically.

- Make the USB connection after the computer is turned on.

Cannot play back images on your computer.

- If you are using "PlayMemories Home", refer to "PlayMemories Home Help Guide". [\[Details\]](#)
- Consult the computer or software manufacturer.

The image and sound are interrupted by noise when you view a movie on a computer.

- You are playing back the movie directly from the internal memory or the memory card. Import the movie to your computer using "PlayMemories Home" and play it back. [\[Details\]](#)

Images once exported to a computer cannot be viewed on the camera.

- Export them to a folder recognized by the camera, such as "101MSDCF", then play back in Folder view. [\[Details\]](#)
- Register the image in the Image Database File and play in [Date View]. [\[Details\]](#)

[▲ Back to top](#)

[▶ Before Use](#)[▶ Shooting](#)[▶ Viewing](#)[▶ Using MENU items \(Shooting\)](#)[▶ Using MENU items \(Viewing\)](#)[▶ Changing settings](#)[▶ Viewing images on a TV](#)[▶ Using with your computer](#)[▶ Printing](#)[▶ Troubleshooting](#)[▶ Precautions / About this camera](#)[➔ Contents list](#)

Memory card

Cannot insert a memory card.

- Insert the memory card in the correct direction.

You have formatted a memory card by mistake.

- All the data on the memory card is deleted by formatting. You cannot restore it.

Images are recorded on the internal memory even when a memory card is inserted into the camera.

- Make sure that the memory card is fully inserted into the camera.

[▲ Back to top](#)

[▶ Before Use](#)[▶ Shooting](#)[▶ Viewing](#)[▶ Using MENU items \(Shooting\)](#)[▶ Using MENU items \(Viewing\)](#)[▶ Changing settings](#)[▶ Viewing images on a TV](#)[▶ Using with your computer](#)[▶ Printing](#)[▶ Troubleshooting](#)[▶ Precautions / About this camera](#)[➔ Contents list](#)

Internal memory

Cannot play back or record images using the internal memory.

- There is a memory card inserted in the camera. Remove it.

Cannot copy the data stored in the internal memory to a memory card.

- The memory card is full. Copy to a memory card with sufficient capacity.

Cannot copy the data on the memory card or the computer to the internal memory.

- This feature is not available.

[▲ Back to top](#)

- ▶ Before Use
- ▶ Shooting
- ▶ Viewing
- ▶ Using MENU items (Shooting)
- ▶ Using MENU items (Viewing)
- ▶ Changing settings
- ▶ Viewing images on a TV
- ▶ Using with your computer
- ▶ Printing
- ▶ Troubleshooting
- ▶ Precautions / About this camera



[→ Contents list](#)

Printing

Images are printed with both edges cut off.

- Depending on your printer, all the edges of the image may be cut off. Especially when you print an image shot with the image size set to [16:9], the lateral end of the image may be cut off.
- When printing images using your printer, cancel the trimming or borderless settings. Consult the printer manufacturer as to whether the printer provides these functions or not.
- When having images printed at a digital print shop, ask the shop whether they can print the images without cutting off both edges.

Cannot print images with the date.

- You can record images with the date with MENU →  (Settings) →  (Shooting Settings) → [Write Date] → [On]. [\[Details\]](#)
Note that you cannot delete a date once it is recorded on an image.
- If you use “PlayMemories Home”, an image without a recorded date can be printed with the date.

[▲ Back to top](#)

- ▶ Before Use
- ▶ Shooting
- ▶ Viewing
- ▶ Using MENU items (Shooting)
- ▶ Using MENU items (Viewing)
- ▶ Changing settings
- ▶ Viewing images on a TV
- ▶ Using with your computer
- ▶ Printing
- ▶ Troubleshooting
- ▶ Precautions / About this camera

[→ Contents list](#)

Others

The lens gets fogged.

- Moisture condensation has occurred. Turn off the camera and leave it for about an hour before using it.

The camera turns off with the lens portion extended.

- The battery pack is discharged. Replace it with a charged battery pack, then turn the camera on again.
- Do not attempt to force the lens that has stopped moving.

The camera becomes warm when you use it for a long time.

- This is not a malfunction.

The Clock Set screen appears when you turn on the camera.

- Set the date and time again. [\[Details\]](#)
- The internal rechargeable backup battery has discharged. Insert a charged battery, and set aside for 24 hours or more with the power left off.

The date or time is incorrect.

- The Area Setting is set to a different location than your current location. Change the setting by MENU →  (Settings) → [Clock Settings] → [Area Setting]. [\[Details\]](#)

[▲ Back to top](#)

- ▶ Before Use
- ▶ Shooting
- ▶ Viewing
- ▶ Using MENU items (Shooting)
- ▶ Using MENU items (Viewing)
- ▶ Changing settings
- ▶ Viewing images on a TV
- ▶ Using with your computer
- ▶ Printing
- ▶ Troubleshooting
- ▶ Precautions / About this camera

[→ Contents list](#)

Self-diagnosis display

If a code starting with a letter of the alphabet appears, the self-diagnosis function on the camera is working.

The last two digits (indicated by) will differ depending on the state of the camera.

If you cannot solve the problem even after trying the following corrective actions a few times, the camera may need repair.

Contact your Sony dealer or local authorized Sony service facility.

C:32:

- There is trouble with the camera's hardware. Turn the power off and on again.
-

C:13:

- The camera cannot read or write data on the memory card. Try turning off and on the camera again, or taking out and inserting the memory card several times.
 - The internal memory has experienced a format error, or an unformatted memory card is inserted. Format the internal memory or the memory card. [\[Details\]](#)
 - The inserted memory card cannot be used with the camera, or the data is damaged. Insert a new memory card.
-

E:61:

E:62:

E:91:

- A camera malfunction has occurred. Initialize the camera, then turn the power on again. [\[Details\]](#)
-

E:94:

- There is a malfunction when writing or deleting data. Repair is required. Contact your Sony dealer or local authorized Sony service facility. Be prepared to give all numbers in the error code beginning from the E.

[▲ Back to top](#)

- ▶ Before Use
- ▶ Shooting
- ▶ Viewing
- ▶ Using MENU items (Shooting)
- ▶ Using MENU items (Viewing)
- ▶ Changing settings
- ▶ Viewing images on a TV
- ▶ Using with your computer
- ▶ Printing
- ▶ Troubleshooting
- ▶ Precautions / About this camera

[→ Contents list](#)

Messages

If the following messages appear, follow the instructions.



- The battery level is low. Charge the battery pack immediately. Depending on the conditions of use or the type of battery pack, the indicator may flash even though there are still 5 minutes to 10 minutes of remaining battery time left.

System error. Turn on the device again.

- Turn the power off and then on again.

Camera overheating Allow it to cool

- The camera temperature has risen. The power may turn off automatically, or you may be unable to record movies. Leave the camera in a cool location until the temperature goes down.

Internal memory error

- Turn the power off and then on again.

Reinsert the memory card.

- The inserted memory card cannot be used in the camera. [\[Details\]](#)
- The terminal section of the memory card is dirty.
- The memory card is damaged.

Incompatible type of memory card.

- The inserted memory card cannot be used in the camera. [\[Details\]](#)

Buffer overflow. Writing to the media was not completed in time.

- If you use a memory card that has been recorded and erased repeatedly, or that was formatted on a different camera, the data writing speed may be too slow. First back up any data on the card to a computer, and then reformat the card before using it. [\[Details\]](#)
- The writing speed of the memory card you are using is not sufficient for movie recordings. Use a “Memory Stick PRO-HG Duo” media, “Memory Stick PRO Duo” (Mark2) media, or an SD card (Class 4 or faster).

Cannot recognize the internal memory. Format and use again.

Cannot recognize this memory card. Format and use again.

- Format the media again. [\[Details\]](#)

The memory card is locked. Check the tab.

- You are using the memory card with the write-protect switch, and the switch is set to the LOCK position. Set the switch to the recording position.

This is a read- only memory card.

- The camera cannot record or delete images on this memory card.

No images

- No images that can be played back have been recorded in the internal memory.
- No images that can be played back have been recorded in this folder of the memory card.

No still images

- The selected folder or date does not contain a file that can be played back in a slideshow.

File found which was not recognized

- You tried to delete a folder containing a file that cannot be played on this camera. Delete the file on a computer and then delete the folder.

Folder error. Cannot record to the selected folder. Please select a different folder.

- A folder with the same first three digit number already exists on the memory card (for example: 123MSDCF and 123ABCDE). Select another folder [\[Details\]](#), or create a new folder [\[Details\]](#).

Cannot create more folders

- The folder with a name beginning with “999” exists on the memory card. You cannot create any folders if this is the case.

Folder protected

- You tried to delete a folder that is protected as read only on a computer.

Cannot display file

- An error occurred while the image was playing back.
No guarantees are made for playing back, on this camera, files containing images which were processed on a computer or images which were shot using other cameras.

Read only folder

- You have selected a folder that cannot be set as a recording folder on the camera. Select another folder. [\[Details\]](#)

File protected

- Release the protection. [\[Details\]](#)

Image size over limit

- You are playing back an image with size that cannot be played back on the camera.

Unable to detect face for retouch

- You may not be able to retouch the image depending on the image.

(Vibration warning indicator)

- Camera shake may occur due to insufficient light. Use the flash, or mount the camera on a tripod to secure the camera.

1280x720 (Fine) is not supported with this memory card.
1280x720 (Standard) is not supported with this memory card.

- For recording movies, it is recommended that you use a memory card of 1 GB or larger.

Turn the power off and on again

- The lens malfunction.

Maximum number of images already selected.

- Up to 100 files can be selected when using [Multiple Images].
- You can add **DPOF** (Print order) marks to up to 999 files.

Error Playing Music

- Delete the Music file, or replace it with a normal Music file.
- Execute [Empty Music], then download a new Music file.

Error Formatting Music

- Execute [Empty Music].

Operation cannot be executed in unsupported files.

- Processing and other editing functions of the camera cannot be performed on image files that have been processed using a computer or images that were recorded with other cameras.

Preparing image database file. Please wait.

- The camera restores the date information, etc., in cases where images have been deleted on a PC, etc.
- The necessary Image Database File is created after the memory card is formatted.



- The number of images exceeds that for which date management in a database file by the camera is possible. To register additional images in the Image Database File, delete images in [Date View].



- It is not possible to record to the camera's Image Database File or play back using [Date View]. Use "PlayMemories Home" to back up all images to a PC and use it to format a memory card.

Image Database File error Cannot recover

- Import all of the images to the computer with "PlayMemories Home", and format the memory card. [\[Details\]](#)
To view the images again with the camera, export the imported images to the camera with "PlayMemories Home".

Recording function unavailable due to high internal temperature.

- The camera temperature has risen. You cannot record images until the temperature has gone down.

Recording has stopped due to increased camera temperature.

- Recording has stopped due to a rise in temperature while recording a movie. Please wait until the temperature goes down.



- When you record movies for a long time, the camera temperature rises. In this case, stop recording movies.

[▲ Back to top](#)

- ▶ Before Use
- ▶ Shooting
- ▶ Viewing
- ▶ Using MENU items (Shooting)
- ▶ Using MENU items (Viewing)
- ▶ Changing settings
- ▶ Viewing images on a TV
- ▶ Using with your computer
- ▶ Printing
- ▶ Troubleshooting
- ▶ Precautions / About this camera

[→ Contents list](#)

[Top page](#) > [Troubleshooting](#) > [Difficult situations for this camera](#) > [Situations this camera has difficulty handling](#)

Situations this camera has difficulty handling

The camera cannot take full advantage of some features under certain circumstances.

When shooting under the following conditions, either recompose the shot or change the shooting mode, then shoot the images again.

Low light conditions

- [Sweep Panorama](#)
- [Tracking focus](#)

Overly bright conditions

- [Tracking focus](#)

Varying levels of brightness

- [Tracking focus](#)

Flickering lights

- [Sweep Panorama](#)

Subjects too close to the camera

- [Sweep Panorama](#)

Subjects too far from the camera

- [Sweep Panorama](#)

Large moving subjects or subjects that move too quickly

- [Sweep Panorama](#)
- [Tracking focus](#)

Subjects too small or too large

- [Tracking focus](#)

Background the same color as the subject

- [Tracking focus](#)

Scenes with little contrast, such as the sky or a sandy beach

- [Sweep Panorama](#)

Scenes changing constantly, such as waves or waterfalls

- [Sweep Panorama](#)

[▲ Back to top](#)

- ▶ [Before Use](#)
- ▶ [Shooting](#)
- ▶ [Viewing](#)
- ▶ [Using MENU items \(Shooting\)](#)
- ▶ [Using MENU items \(Viewing\)](#)
- ▶ [Changing settings](#)
- ▶ [Viewing images on a TV](#)
- ▶ [Using with your computer](#)
- ▶ [Printing](#)
- ▶ [Troubleshooting](#)
- ▶ [Precautions / About this camera](#)

[→ Contents list](#)

Precautions

- ▼ [Internal memory and memory card back up](#)
- ▼ [On database files](#)
- ▼ [Do not use/store the camera in the following places](#)
- ▼ [On carrying](#)
- ▼ [On operating temperatures](#)
- ▼ [On moisture condensation](#)
- ▼ [On image data compatibility](#)
- ▼ [Notes on the screen and lens](#)
- ▼ [Notes on the flash](#)

Internal memory and memory card back up

Do not turn off the camera, remove the battery pack, or remove the memory card while the access lamp is lit. Otherwise, the internal memory data or the memory card may be damaged. Be sure to make a backup copy to protect your data.

On database files

When you insert a memory card without a database file into the camera and turn on the power, part of the memory card capacity is used to automatically create a database file. It may take some time until you can perform the next operation.

Do not use/store the camera in the following places

- In an extremely hot, cold or humid place
In places such as in a car parked in the sun, the camera body may become deformed and this may cause a malfunction.
- Under direct sunlight or near a heater
The camera body may become discolored or deformed, and this may cause a malfunction.
- In a location subject to rocking vibration
- Near strong magnetic place
- In sandy or dusty places
Be careful not to let sand or dust get into the camera. This may cause the camera to malfunction, and in some cases this malfunction cannot be repaired.

On carrying

- Do not sit down in a chair or other place with the camera in the back pocket of your trousers or skirt, as this may cause malfunction or damage the camera.

On operating temperatures

- Your camera is designed for use under the temperatures between 0°C to 40°C (32°F to 104°F). Shooting in extremely cold or hot places that exceed this range is not recommended.

On moisture condensation

- If the camera is brought directly from a cold to a warm location, moisture may condense inside or outside the camera. This moisture condensation may cause a malfunction of the camera.
- If moisture condensation occurs, turn off the camera and wait about an hour for the moisture to evaporate. Note that if you attempt to shoot with moisture remaining inside the lens, you will be unable to record clear images.

On image data compatibility

- The camera conforms with DCF (Design rule for Camera File system) universal standard established by JEITA (Japan Electronics and Information Technology Industries Association).
- Sony does not guarantee that the camera will play back images recorded or edited with other equipment, or that other equipment will play back images recorded with the camera.

Notes on the screen and lens

- The screen is manufactured using extremely high-precision technology so over 99.99% of the pixels are operational for effective use. However, some tiny black and/or bright dots (white, red, blue or green) may appear on the screen. These dots are a normal result of the manufacturing process and do not affect the recording.
- Exposing the screen or the lens to direct sunlight for long periods may cause malfunctions. Be careful when placing the camera near a window or outdoors.
- Do not press against the screen. The screen may be discolored and that may cause a malfunction.
- Images may trail across on the screen in a cold location. This is not a malfunction.
- Be careful not to bump the movable lens, and be careful not to apply force to it.

Notes on the flash

- When using the flash, the flash pops up automatically.
- The flash may go down automatically. [\[Details\]](#)
- Do not cover the flash with your fingers.
- Do not carry the camera by the flash unit, or use excessive strength on it.
- If water, dust or sand gets into the open flash unit, it may cause a malfunction.

[▲ Back to top](#)

[Top page](#) > [Precautions / About this camera](#) > [Precautions](#) > [On the internal rechargeable backup battery](#)

- ▶ [Before Use](#)
- ▶ [Shooting](#)
- ▶ [Viewing](#)
- ▶ [Using MENU items \(Shooting\)](#)
- ▶ [Using MENU items \(Viewing\)](#)
- ▶ [Changing settings](#)
- ▶ [Viewing images on a TV](#)
- ▶ [Using with your computer](#)
- ▶ [Printing](#)
- ▶ [Troubleshooting](#)
- ▶ [Precautions / About this camera](#)

[→ Contents list](#)

On the internal rechargeable backup battery

This camera has an internal rechargeable battery for maintaining the date and time and other settings regardless of whether the power is on or off.

This rechargeable battery is continually charged as long as you are using the camera. However, if you use the camera for only short periods, it discharges gradually, and if you do not use the camera at all for about one month it becomes completely discharged. In this case, be sure to charge this rechargeable battery before using the camera.

However, even if this rechargeable battery is not charged, you can still use the camera, but the date and time will not be indicated.

Charging method of the internal rechargeable backup battery

Insert charged battery pack in the camera, and then leave the camera for 24 hours or more with the power off.

[▲ Back to top](#)

- ▶ Before Use
- ▶ Shooting
- ▶ Viewing
- ▶ Using MENU items (Shooting)
- ▶ Using MENU items (Viewing)
- ▶ Changing settings
- ▶ Viewing images on a TV
- ▶ Using with your computer
- ▶ Printing
- ▶ Troubleshooting
- ▶ Precautions / About this camera

[→ Contents list](#)

Battery pack

- ▼ [On charging the battery pack](#)
- ▼ [Effective use of the battery pack](#)
- ▼ [About the remaining battery charge](#)
- ▼ [How to store the battery pack](#)
- ▼ [On battery life](#)
- ▼ [Compatible battery pack](#)

On charging the battery pack

- Charge the battery pack (supplied) before using the camera for the first time.
- You can charge the battery pack even if it is not completely discharged. In addition, even if the battery pack is not fully charged, you can use the partially charged capacity of the battery pack as is.
- We recommend charging the battery pack in an ambient temperature of between 10°C to 30°C (50°F to 86°F). The battery pack may not be effectively charged in temperatures outside this range.

Effective use of the battery pack

- Battery performance decreases in low temperature surroundings. So in cold places, the operational time of the battery pack is shorter. We recommend the following to ensure longer battery pack use:
 - Put the battery pack in a pocket close to your body to warm it up, and insert it in the camera immediately before you start shooting.
(if there are any metal objects such as a key in your pocket, be aware of short-circuiting.)
- The battery pack will run out quickly if you use the flash or zoom frequently.
- We recommend having spare battery packs handy for two times or three times the expected shooting time, and making trial shots before taking the actual shots.
- Do not expose the battery pack to water. The battery pack is not water-resistant.
- Do not leave the battery pack in extremely hot places, such as in a car or under direct sunlight.
- You may not be able to turn on the camera or the battery pack may not be effectively charged if the terminal section of the battery is dirty. In this case, wipe any dust with a soft cloth lightly to clean the battery.

About the remaining battery charge

- A remaining charge indicator appears on the screen.



A: High

B: Low

- The remaining charge indicator may not be displayed correctly in the following situations:
 - Using the camera for a long time in high temperature
 - Leaving the camera with fully charged battery
 - Using a heavily used battery
- It takes about one minute until the correct remaining charge indicator appears.
- The remaining charge indicator may not be correct under certain circumstances.

- When [Eco Mode] is set to [Standard] or [Max], if you do not operate the camera for a certain period of time while the power is on, the screen becomes dark, then the camera turns off automatically (Auto power-off function).

How to store the battery pack

- Fully discharge the battery pack before storing and store it in a cool, dry place. To maintain the battery pack's function, fully charge the battery pack and then fully discharge it on the camera at least once a year while storing.
- To use the battery pack up, leave the camera in slideshow playback mode until the power goes off.
- To prevent staining the terminal, short-circuiting, etc., be sure to use a supplied battery case when carrying or storing.

On battery life

- The battery life is limited. Battery capacity decreases over time and through repeated use. If decreased usage time between charges becomes significant, it is probably time to replace it with a new one.
- The battery life varies according to how it is stored and the operating conditions and environment in which each battery pack is used.

Compatible battery pack

- The NP-BG1 (supplied) can be used only in G type compatible Cyber-shot models.
- If you use the NP-FG1 battery pack (sold separately), the minutes also appear after the battery remaining indicator ( 60 Min).

[▲ Back to top](#)

Copyright 2012 Sony Corporation

▶ Before Use
▶ Shooting
▶ Viewing
▶ Using MENU items (Shooting)
▶ Using MENU items (Viewing)
▶ Changing settings
▶ Viewing images on a TV
▶ Using with your computer
▶ Printing
▶ Troubleshooting
▶ Precautions / About this camera

[→ Contents list](#)

Battery charger

- NP-BG1 type (supplied), NP-FG1 type (sold separately) battery packs (and no others) can be charged in the battery charger (supplied). Batteries other than the specified kind may leak, overheat, or explode if you attempt to charge them, posing a risk of injury from electrocution and burns.
- Remove the charged battery pack from the battery charger. If you leave the charged battery pack in the charger, battery life may be shortened.
- The CHARGE lamp of the supplied battery charger flashes in either way:
 - Fast flashing: Turns the light on and off repeatedly at the interval of approximately 0.15 seconds.
 - Slow flashing: Turns the light on and off repeatedly at the interval of approximately 1.5 seconds.
- When the CHARGE lamp flashes fast, remove the battery pack being charged, and then insert the same battery pack into the battery charger securely again. When the CHARGE lamp flashes fast again, this may indicate a battery error or that a battery pack other than the specified type has been inserted. Check that the battery pack is the specified type. If the battery pack is the specified type, remove the battery pack, replace it with a new one or another one and check if the battery charger operates correctly. If the battery charger operates correctly, a battery error may have occurred.
- When the CHARGE lamp flashes slowly, it indicates that the battery charger stops charging temporarily on standby. The battery charger stops charging and enters the standby status automatically when the temperature is outside of the recommended operating temperature. When the temperature gets back within the appropriate range, the battery charger resumes charging and the CHARGE lamp lights up again. We recommend charging the battery pack in an ambient temperature of between 10°C to 30°C (50°F to 86°F).

[▲ Back to top](#)

- ▶ Before Use
- ▶ Shooting
- ▶ Viewing
- ▶ Using MENU items (Shooting)
- ▶ Using MENU items (Viewing)
- ▶ Changing settings
- ▶ Viewing images on a TV
- ▶ Using with your computer
- ▶ Printing
- ▶ Troubleshooting
- ▶ Precautions / About this camera

[→ Contents list](#)

Memory card

- ▼ [Memory card](#)
- ▼ [Note on using the memory card adaptor \(sold separately\)](#)
- ▼ [“Memory Stick” media](#)
- ▼ [When using a “Memory Stick Duo” media with standard sized “Memory Stick” media slot](#)
- ▼ [Notes on using a “Memory Stick Micro” media \(sold separately\)](#)

Memory card

Types of memory card	In this manual
Memory Stick PRO Duo	“Memory Stick Duo” media
Memory Stick PRO-HG Duo	
Memory Stick Duo	
Memory Stick Micro	“Memory Stick Micro” media
Memory Stick Micro (Mark2)	
SD memory card	SD card
SDHC memory card	
SDXC memory card	
microSD memory card	microSD memory card
microSDHC memory card	

- MultiMediaCard cannot be used.
- “Memory Stick Duo” media of up to 32 GB and SD cards of up to 64 GB have been tested and proven to operate with your camera.
- “Memory Stick Micro” media of up to 16 GB and microSD memory cards of up to 32 GB have been tested and proven to operate with your camera.
- When recording movies, it is recommended that you use the following memory cards:
 - **MEMORY STICK PRO DUO** (Mark2) (“Memory Stick PRO Duo” (Mark2) media)
 - **MEMORY STICK PRO-HG DUO** (“Memory Stick PRO-HG Duo” media)
 - **MEMORY STICK MICRO** (Mark2) (“Memory Stick Micro” (Mark2) media)
 - SD card (Class 4 or faster)
 - microSD memory card (Class 4 or faster)

Notes

- To ensure stable operations of the memory card, we recommend that you use this camera to format any memory card being used with this camera for the first time. Note that formatting will erase all data recorded on the memory card. This data cannot be restored. Be sure to backup any important data to a PC or other storage location.
- A memory card formatted with a computer is not guaranteed to operate with the camera.
- Data read/write speeds differ depending on the combination of the memory card and the equipment used.
- Data may be corrupted in the following cases:
 - When the memory card is removed or the camera is turned off during a read or write operation
 -

- When the memory card is used in locations subject to static electricity or electrical noise
- We recommend backing up important data.
- Do not attach a label on the memory card itself nor on a memory card adaptor.
- Do not touch the terminal section of the memory card with your hand or a metal object.
- Do not strike, bend or drop the memory card.
- Do not disassemble or modify the memory card.
- Do not expose the memory card to water.
- Do not leave the memory card within the reach of small children. They might accidentally swallow it.
- Insert a memory card that fits the memory card slot size. Otherwise, it will cause a malfunction.
- Do not use or store the memory card under the following conditions:
 - High temperature locations such as the hot interior of a car parked in direct sunlight
 - Locations exposed to direct sunlight
 - Humid locations or locations with corrosive substances present

Note on using the memory card adaptor (sold separately)

- When inserting a memory card into a memory card adaptor, make sure the memory card is inserted facing in the correct direction, then insert it all the way in. Incorrect insertion may result in a malfunction.

“Memory Stick” media

The types of “Memory Stick Duo” media that can be used with the camera are listed in the table below. However, proper operation cannot be guaranteed for all “Memory Stick Duo” media functions.

“Memory Stick” media type	Recording/Playback
Memory Stick Duo (without MagicGate)	○ *1
Memory Stick Duo (with MagicGate)	○ *2
MagicGate Memory Stick Duo	○ *1*2
Memory Stick PRO Duo	○ *2*3
Memory Stick PRO-HG Duo	○ *2*3*4
Memory Stick Micro	○ *2
Memory Stick Micro (Mark2)	○ *2*3

*1 High-speed data transfer using a parallel interface is not supported.

*2 “Memory Stick Duo” media, “MagicGate Memory Stick Duo” media, “Memory Stick PRO Duo” media, “Memory Stick PRO-HG Duo” media, “Memory Stick Micro” media and “Memory Stick Micro” (Mark2) media are equipped with MagicGate functions. MagicGate is copyright protection technology that uses encryption technology. Data recording/playback that requires MagicGate functions cannot be performed with the camera.

*3 [1280×720] size movies can be recorded.

*4 This camera does not support 8-bit parallel data transfer. It performs the same 4-bit parallel data transfer as the “Memory Stick PRO Duo” media.

When using a “Memory Stick Duo” media with standard sized “Memory Stick” media slot

You can use the “Memory Stick Duo” media by inserting it into the “Memory Stick Duo” media Adaptor (sold separately).



■ Notes on using a “Memory Stick Micro” media (sold separately)

- This product is compatible with “Memory Stick Micro” media (“M2”). “M2” is an abbreviation for “Memory Stick Micro” media.
- To use a “Memory Stick Micro” media with the camera, be sure to insert the “Memory Stick Micro” media into an “M2” Adaptor as large as of Duo size. If you insert a “Memory Stick Micro” media into the camera without an “M2” Adaptor as large as of Duo size, you might not be able to remove it from the camera.
- Do not leave the “Memory Stick Micro” media within the reach of small children. They might accidentally swallow it.

[▲ Back to top](#)

- ▶ Before Use
- ▶ Shooting
- ▶ Viewing
- ▶ Using MENU items (Shooting)
- ▶ Using MENU items (Viewing)
- ▶ Changing settings
- ▶ Viewing images on a TV
- ▶ Using with your computer
- ▶ Printing
- ▶ Troubleshooting
- ▶ Precautions / About this camera

[→ Contents list](#)

On cleaning

Cleaning the lens and flash

Wipe the lens and flash with a soft cloth to remove fingerprints, dust, etc.

Cleaning the flash

Clean the flash surface before use. The heat of flash emission may cause dirt on the flash surface to start smoking or burning. Wipe the flash surface with a soft cloth to remove dirt or dust, etc.

Cleaning the camera surface

Clean the camera surface with a soft cloth slightly moistened with water, then wipe the surface with a dry cloth. To prevent damage to the finish or casing:

- Do not expose the camera to chemical products such as thinner, benzine, alcohol, disposable cloths, insect repellent, sunscreen or insecticide.
- Do not touch the camera with any of the above on your hand.
- Do not leave the camera in contact with rubber or vinyl for a long time.

[▲ Back to top](#)

[Top page](#) > [Precautions / About this camera](#) > [Number of still images and recordable time of movies](#) > [Number of still images](#)

▶ Before Use

▶ Shooting

▶ Viewing

▶ Using MENU items (Shooting)

▶ Using MENU items (Viewing)

▶ Changing settings

▶ Viewing images on a TV

▶ Using with your computer

▶ Printing

▶ Troubleshooting

▶ **Precautions / About this camera**

[→ Contents list](#)

Number of still images

(Units: Images)

Size	Internal memory	Memory card formatted with this camera				
	Approx. 27 MB	2 GB	4 GB	8 GB	16 GB	32 GB
16M	4	265	530	1050	2150	4300
10M	6	400	800	1600	3200	6400
5M	8	580	1150	2300	4650	9300
VGA	165	11000	22000	44000	88000	175000
16:9(12M)	4	330	660	1300	2650	5300
16:9(2M)	30	2050	4100	8200	16000	32500

Notes

- When the number of remaining shootable images is greater than 9,999, the “>9999” indicator appears.
- When an image shot with other cameras is played back on this camera, the image may not appear in the actual image size.

[▲ Back to top](#)

[Top page](#) > [Precautions / About this camera](#) > [Number of still images and recordable time of movies](#) > [Recordable time of movies](#)

- ▶ Before Use
- ▶ Shooting
- ▶ Viewing
- ▶ Using MENU items (Shooting)
- ▶ Using MENU items (Viewing)
- ▶ Changing settings
- ▶ Viewing images on a TV
- ▶ Using with your computer
- ▶ Printing
- ▶ Troubleshooting
- ▶ [Precautions / About this camera](#)

[→ Contents list](#)

Recordable time of movies

The table below shows the approximate maximum recording times. These are the total times for all movie files.

(h (hour), m (minute), s (second))

Quality / Size	Internal memory	Memory card formatted with this camera				
	Approx. 27 MB	2 GB	4 GB	8 GB	16 GB	32 GB
1280x720(Fine)	—	20m (15m)	45m (35m)	1h 35m (1h 10m)	3h 10m (2h 20m)	6h 20m (4h 40m)
1280x720(Standard)	—	35m (25m)	1h 10m (50m)	2h 20m (1h 40m)	4h 40m (3h 25m)	9h 20m (6h 55m)
VGA	1m (45s)	1h 05m (50m)	2h 10m (1h 40m)	4h 25m (3h 20m)	8h 50m (6h 40m)	17h 45m (13h 25m)

The number in () is the minimum recordable time.

Continuous shooting is possible for approximately 29 minutes at one time. The maximum size of a movie file is up to approximately 2 GB.

Notes

- The recordable time of movies varies because the camera is equipped with VBR (Variable Bit Rate), which automatically adjusts image quality depending on the shooting scene. When you record a fast-moving subject, the image is clearer but the recordable time is shorter because more memory is required for recording. The recordable time also varies depending on the shooting conditions, the subject or the image size settings.
- You cannot record movies to the internal memory when the movie image size is [1280x720(Fine)] or [1280x720(Standard)].

[▲ Back to top](#)

[Top page](#) > [Precautions / About this camera](#) > [Using the camera abroad](#) > [Using the camera abroad](#)

▶ Before Use

▶ Shooting

▶ Viewing

▶ Using MENU items (Shooting)

▶ Using MENU items (Viewing)

▶ Changing settings

▶ Viewing images on a TV

▶ Using with your computer

▶ Printing

▶ Troubleshooting

▶ Precautions / About this camera

[→ Contents list](#)

Using the camera abroad

You can use the battery charger (supplied) in any country or region where the power supply is within 100 V to 240 V AC, 50 Hz/60 Hz.

Note

- An electronic voltage transformer is unnecessary and its use may cause a malfunction.

[▲ Back to top](#)

[Top page](#) > [Precautions / About this camera](#) > [Using the camera abroad](#) > [On TV color systems](#)

- ▶ Before Use
- ▶ Shooting
- ▶ Viewing
- ▶ Using MENU items (Shooting)
- ▶ Using MENU items (Viewing)
- ▶ Changing settings
- ▶ Viewing images on a TV
- ▶ Using with your computer
- ▶ Printing
- ▶ Troubleshooting
- ▶ Precautions / About this camera

[→ Contents list](#)

On TV color systems

If you want to view images on a TV screen, you need a TV with a video input jack and the cable for multi-use terminal. The color system of the TV must match that of the digital still camera. Check the following lists for the TV color system of the country or region where the camera is used.

NTSC system

Bahama Islands, Bolivia, Canada, Central America, Chile, Colombia, Ecuador, Jamaica, Japan, Korea, Mexico, Peru, Surinam, Taiwan, the Philippines, the U.S.A., Venezuela, etc.

PAL system

Australia, Austria, Belgium, China, Croatia, Czech Republic, Denmark, Finland, Germany, Holland, Hong Kong, Hungary, Indonesia, Italy, Kuwait, Malaysia, New Zealand, Norway, Poland, Portugal, Romania, Singapore, Slovak Republic, Spain, Sweden, Switzerland, Thailand, Turkey, United Kingdom, Viet Nam, etc.

PAL-M system

Brazil

PAL-N system

Argentina, Paraguay, Uruguay

SECAM system

Bulgaria, France, Greece, Guiana, Iran, Iraq, Monaco, Russia, Ukraine, etc.

[▲ Back to top](#)

- ▶ Before Use
- ▶ Shooting
- ▶ Viewing
- ▶ Using MENU items (Shooting)
- ▶ Using MENU items (Viewing)
- ▶ Changing settings
- ▶ Viewing images on a TV
- ▶ Using with your computer
- ▶ Printing
- ▶ Troubleshooting
- ▶ Precautions / About this camera

[→ Contents list](#)

License

Notes on the License

This camera comes with software that are used based on licensing agreements with the owners of that software. Based on requests by the owners of copyright of these software applications, we have an obligation to inform you of the following. Please read the following sections.

Licenses (in English) are recorded in the internal memory of your camera. Establish a Mass Storage connection between the camera and a computer to read licenses in the "PMHOME" - "LICENSE" folder.

THIS PRODUCT IS LICENSED UNDER THE AVC PATENT PORTFOLIO LICENSE FOR THE PERSONAL AND NON-COMMERCIAL USE OF A CONSUMER TO

(i) ENCODE VIDEO IN COMPLIANCE WITH THE AVC STANDARD ("AVC VIDEO")
AND/OR

(ii) DECODE AVC VIDEO THAT WAS ENCODED BY A CONSUMER ENGAGED IN A PERSONAL AND NON-COMMERCIAL ACTIVITY AND/OR WAS OBTAINED FROM A VIDEO PROVIDER LICENSED TO PROVIDE AVC VIDEO.

NO LICENSE IS GRANTED OR SHALL BE IMPLIED FOR ANY OTHER USE.

ADDITIONAL INFORMATION MAY BE OBTAINED FROM MPEG LA, L.L.C. SEE

[HTTP://WWW.MPEGLA.COM](http://www.mpegla.com)

On the license of "Music Transfer"

MPEG Layer-3 audio coding technology and patents licensed from Fraunhofer IIS and Thomson.

[▲ Back to top](#)

- ▶ Before Use
- ▶ Shooting
- ▶ Viewing
- ▶ Using MENU items (Shooting)
- ▶ Using MENU items (Viewing)
- ▶ Changing settings
- ▶ Viewing images on a TV
- ▶ Using with your computer
- ▶ Printing
- ▶ Troubleshooting
- ▶ Precautions / About this camera

[→ Contents list](#)

Trademarks

- The following marks are trademarks of Sony Corporation.
Cyber-shot, “Cyber-shot,” “Memory Stick,” , “Memory Stick PRO,” **MEMORY STICK PRO**,
 “Memory Stick Duo,” **MEMORY STICK DUO**, “Memory Stick PRO Duo,”
MEMORY STICK PRO DUO, “Memory Stick PRO-HG Duo,” **MEMORY STICK PRO-HG DUO**,
 “Memory Stick Micro,” **MEMORY STICK MICRO**, “MagicGate,” **MAGICGATE**
- Microsoft, Windows, DirectX and Windows Vista are either registered trademarks or trademarks of Microsoft Corporation in the United States and/or other countries.
- Mac and Mac OS are trademarks or registered trademarks of Apple Inc.
- Intel, Pentium and Intel Core are trademarks or registered trademarks of Intel Corporation.
- SDXC logo is a trademark of SD-3C, LLC.
- MultiMediaCard is a trademark of MultiMediaCard Association.
- Eye-Fi is a trademark of Eye-Fi, Inc.
- In addition, system and product names used in this manual are, in general, trademarks or registered trademarks of their respective developers or manufacturers. However, the TM or ® marks are not used in all cases in this manual.

[▲ Back to top](#)