

- ▶ Operation Search
- ▶ Before Use
- ▶ Shooting
- ▶ Viewing
- ▶ Using 3D Functions
- ▶ Using MENU items (Shooting)
- ▶ Using MENU items (Viewing)
- ▶ Changing settings
- ▶ Viewing images on a TV
- ▶ Using with your computer
- ▶ Printing
- ▶ Troubleshooting
- ▶ Precautions/About this camera

[→ Contents list](#)

DSC-WX7/WX9

User Guide

Use this manual if you encounter any problems, or have any questions about the camera.



Cyber-shot

[▲ Back to top](#)

Table Of Contents

DSC-WX7/WX9 User Guide.....	i
Operation Search.....	1
Search by Operation.....	20
Before Use.....	2
How to use this User Guide.....	22
The images and illustrations used in this User Guide.....	25
Names of parts.....	26
List of icons displayed on the screen.....	28
Using the wrist strap.....	32
Using the control wheel.....	33
Using the internal memory.....	35
In-Camera Guide.....	36
Shooting.....	3
Shooting still images.....	38
Zoom.....	40
Shooting movies.....	41
Shooting still images while recording a movie (Dual Rec).....	42
Shooting panoramic images.....	43
List of mode switch functions.....	46
Intelligent Auto.....	47
Superior Auto.....	48
Program Auto.....	50
3D Still Image.....	51
Scene Selection.....	52
Background Defocus.....	55
Functions not available in some REC modes.....	57
Tracking focus.....	58
DISP (Display Setting).....	59
Flash.....	61
Burst Settings.....	62
Self-Timer.....	63
Viewing.....	4
Viewing still images.....	65
Playback zoom.....	66
Image Index.....	67
Delete button.....	69
Viewing burst images.....	71
Viewing movies.....	73

Scrolling the panorama images for display.....	75
Using 3D Functions.....	5
3D Functions.....	76
File name of the 3D image.....	77
3D Still Image.....	78
3D Sweep Panorama.....	79
Sweep Multi Angle.....	81
Viewing images shot in Sweep Multi Angle mode stereoscopically.....	83
Viewing 3D images on a 3D TV.....	84
Using MENU items (Shooting).....	6
Using MENU items (Shooting).....	86
REC Mode.....	87
Movie shooting scene.....	88
Panorama Shooting Scene.....	89
Scene Selection.....	90
Easy Mode.....	93
Defocus Effect.....	95
Still Image Size/Panorama Image Size.....	96
Movie Quality/Movie Size.....	99
EV.....	100
ISO.....	101
White Balance.....	103
Focus.....	105
Metering Mode.....	107
Burst Shooting Interval.....	108
Scene Recognition.....	109
Soft Skin Effect.....	111
Smile Shutter.....	112
Smile Detection Sensitivity.....	114
Face Detection.....	115
Anti Blink.....	116
In-Camera Guide.....	117
MENU items not available in some REC modes.....	118
Using MENU items (Viewing).....	7
Using MENU items (Viewing).....	120
Easy Mode.....	121
Slideshow.....	122
3D Viewing.....	125
Send by TransferJet.....	126
View Mode.....	128

Display Burst Group.....	129
Retouch.....	130
Delete.....	132
Protect.....	133
Print (DPOF).....	134
Rotate.....	135
In-Camera Guide.....	136
MENU items that cannot be set according to View Mode.....	137
Changing settings.....	8
Changing camera settings.....	138
Movie format.....	140
AF Illuminator.....	141
Grid Line.....	142
Digital Zoom.....	143
Wind Noise Reduct.....	144
Red Eye Reduction.....	145
Blink Alert.....	146
Write Date.....	147
Beep.....	148
Panel Brightness.....	149
Language Setting.....	150
Display color.....	151
Demo Mode.....	152
Initialize.....	153
Function Guide.....	154
CTRL FOR HDMI.....	155
USB Connect Setting.....	156
USB Power Supply.....	157
LUN Setting.....	158
Download Music.....	159
Empty Music.....	160
TransferJet.....	161
Eye-Fi.....	163
Power Save.....	165
Format.....	166
Create REC.Folder.....	167
Change REC.Folder.....	168
Delete REC.Folder.....	169
Copy.....	170
File Number.....	171

Area Setting.....	172
Date & Time Setting.....	173
Viewing images on a TV.....	9
Viewing an image on an HD TV using the HDMI Cable.....	174
Viewing an image on a “BRAVIA” Sync-compatible TV	176
Viewing an image on a Standard Definition (SD) TV.....	178
Using with your computer.....	10
Recommended computer environment (Windows).....	179
Recommended computer environment (Macintosh).....	180
“PMB (Picture Motion Browser)”	181
“Music Transfer”	182
Installing “PMB” and “Music Transfer” (Windows)	183
Installing “Music Transfer” (Macintosh)	184
Connecting the camera to the computer.....	185
Importing images to a computer (Windows).....	186
Importing images to a computer (Macintosh).....	187
Deleting the USB connection.....	188
“PMB Portable”	189
Starting up “PMB Portable” (Windows)	190
Starting up “PMB Portable” (Macintosh)	191
Selecting the method for creating a disc of movies.....	192
Creating AVCHD discs.....	194
Creating standard definition image quality (STD) discs.....	195
Creating Blu-ray discs.....	196
Printing.....	11
Printing still images.....	197
Printing at a shop.....	198
Troubleshooting.....	12
If you have problems.....	199
Battery pack and power.....	200
Shooting still images/movies.....	202
Viewing images.....	205
Deleting.....	206
Computers.....	207
Memory card.....	209
Internal memory.....	210
Printing.....	211
Others.....	212
Self-diagnosis display.....	213
Messages.....	214

Precautions/About this camera.....	13
Precautions.....	219
On the internal rechargeable backup battery.....	222
Battery pack.....	223
AC Adaptor.....	225
Memory card.....	226
On cleaning.....	229
Number of still images.....	230
Recordable time of movies.....	231
Using the camera abroad.....	232
On TV color systems.....	233
Intelligent Pan/tilt.....	234
Carl Zeiss lens.....	235
AVCHD format.....	236
TransferJet standard.....	237
License.....	238
Trademarks.....	239

- ▶ Operation Search
- ▶ Before Use
- ▶ Shooting
- ▶ Viewing
- ▶ Using 3D Functions
- ▶ Using MENU items (Shooting)
- ▶ Using MENU items (Viewing)
- ▶ Changing settings
- ▶ Viewing images on a TV
- ▶ Using with your computer
- ▶ Printing
- ▶ Troubleshooting
- ▶ Precautions/About this camera

[➡ Contents list](#)

Operation Search

Operation Search

[Search by Operation](#)

[▲ Back to top](#)

- ▶ Operation Search
- ▶ **Before Use**
- ▶ Shooting
- ▶ Viewing
- ▶ Using 3D Functions
- ▶ Using MENU items (Shooting)
- ▶ Using MENU items (Viewing)
- ▶ Changing settings
- ▶ Viewing images on a TV
- ▶ Using with your computer
- ▶ Printing
- ▶ Troubleshooting
- ▶ Precautions/About this camera

[➡ Contents list](#)

Before Use

How to use this User Guide

[How to use this User Guide](#)

[The images and illustrations used in this User Guide](#)

Names of parts and list of icons displayed on the screen

[Names of parts](#)

[List of icons displayed on the screen](#)

Using the wrist strap

[Using the wrist strap](#)

Using the control wheel

[Using the control wheel](#)

Using the internal memory

[Using the internal memory](#)

Using the In-Camera guide

[In-Camera Guide](#)

[▲ Back to top](#)

- ▶ Operation Search
- ▶ Before Use
- ▶ Shooting
- ▶ Viewing
- ▶ Using 3D Functions
- ▶ Using MENU items (Shooting)
- ▶ Using MENU items (Viewing)
- ▶ Changing settings
- ▶ Viewing images on a TV
- ▶ Using with your computer
- ▶ Printing
- ▶ Troubleshooting
- ▶ Precautions/About this camera

[➡ Contents list](#)

Shooting

Shooting still images

- [Shooting still images](#)
- [Zoom](#)

Shooting movies

- [Shooting movies](#)
- [Shooting still images while recording a movie \(Dual Rec\)](#)

Shooting panoramic images

- [Shooting panoramic images](#)

Setting still image shooting mode

- [List of mode switch functions](#)
- [Intelligent Auto](#)
- [Superior Auto](#)
- [Program Auto](#)
- [3D Still Image](#)
- [Scene Selection](#)
- [Background Defocus](#)
- [Functions not available in some REC modes](#)

Using shooting functions

- [Tracking focus](#)
- [DISP \(Display Setting\)](#)
- [Flash](#)
- [Burst Settings](#)
- [Self-Timer](#)

[▲ Back to top](#)

- ▶ Operation Search
- ▶ Before Use
- ▶ Shooting
- ▶ Viewing
- ▶ Using 3D Functions
- ▶ Using MENU items (Shooting)
- ▶ Using MENU items (Viewing)
- ▶ Changing settings
- ▶ Viewing images on a TV
- ▶ Using with your computer
- ▶ Printing
- ▶ Troubleshooting
- ▶ Precautions/About this camera

[➡ Contents list](#)

Viewing

Viewing still images

- [Viewing still images](#)
- [Playback zoom](#)
- [Image Index](#)

Deleting images

- [Delete button](#)

Viewing burst images

- [Viewing burst images](#)

Viewing movies

- [Viewing movies](#)

Viewing panorama images

- [Scrolling the panorama images for display](#)

[▲ Back to top](#)

- ▶ Operation Search
- ▶ Before Use
- ▶ Shooting
- ▶ Viewing
- ▶ Using 3D Functions
- ▶ Using MENU items (Shooting)
- ▶ Using MENU items (Viewing)
- ▶ Changing settings
- ▶ Viewing images on a TV
- ▶ Using with your computer
- ▶ Printing
- ▶ Troubleshooting
- ▶ Precautions/About this camera

[➡ Contents list](#)

Using 3D Functions

3D Functions

- [3D Functions](#)
- [File name of the 3D image](#)

Shooting 3D images

- [3D Still Image](#)
- [3D Sweep Panorama](#)
- [Sweep Multi Angle](#)

Viewing 3D images

- [Viewing images shot in Sweep Multi Angle mode stereoscopically](#)
- [Viewing 3D images on a 3D TV](#)

[▲ Back to top](#)

▶ Operation Search
▶ Before Use
▶ Shooting
▶ Viewing
▶ Using 3D Functions
▶ Using MENU items (Shooting)
▶ Using MENU items (Viewing)
▶ Changing settings
▶ Viewing images on a TV
▶ Using with your computer
▶ Printing
▶ Troubleshooting
▶ Precautions/About this camera

[➡ Contents list](#)

Using MENU items (Shooting)

Using MENU items (Shooting)

[Using MENU items \(Shooting\)](#)

MENU items (Shooting)

[REC Mode](#)
[Movie shooting scene](#)
[Panorama Shooting Scene](#)
[Scene Selection](#)
[Easy Mode](#)
[Defocus Effect](#)
[Still Image Size/Panorama Image Size](#)
[Movie Quality/Movie Size](#)
[EV](#)
[ISO](#)
[White Balance](#)
[Focus](#)
[Metering Mode](#)
[Burst Shooting Interval](#)
[Scene Recognition](#)
[Soft Skin Effect](#)
[Smile Shutter](#)
[Smile Detection Sensitivity](#)
[Face Detection](#)
[Anti Blink](#)
[In-Camera Guide](#)

Shooting MENU list

[MENU items not available in some REC modes](#)

[▲ Back to top](#)

- ▶ Operation Search
- ▶ Before Use
- ▶ Shooting
- ▶ Viewing
- ▶ Using 3D Functions
- ▶ Using MENU items (Shooting)
- ▶ Using MENU items (Viewing)
- ▶ Changing settings
- ▶ Viewing images on a TV
- ▶ Using with your computer
- ▶ Printing
- ▶ Troubleshooting
- ▶ Precautions/About this camera

[➡ Contents list](#)

Using MENU items (Viewing)

Using MENU items (Viewing)

[Using MENU items \(Viewing\)](#)

MENU items (Viewing)

- [Easy Mode](#)
- [Slideshow](#)
- [3D Viewing](#)
- [Send by TransferJet](#)
- [View Mode](#)
- [Display Burst Group](#)
- [Retouch](#)
- [Delete](#)
- [Protect](#)
- [Print \(DPOF\)](#)
- [Rotate](#)
- [In-Camera Guide](#)

Playback MENU list

[MENU items that cannot be set according to View Mode](#)

[▲ Back to top](#)

- ▶ Operation Search
- ▶ Before Use
- ▶ Shooting
- ▶ Viewing
- ▶ Using 3D Functions
- ▶ Using MENU items (Shooting)
- ▶ Using MENU items (Viewing)
- ▶ Changing settings
- ▶ Viewing images on a TV
- ▶ Using with your computer
- ▶ Printing
- ▶ Troubleshooting
- ▶ Precautions/About this camera

[➡ Contents list](#)

Changing settings

Changing settings

[Changing camera settings](#)

Shooting Settings

[Movie format](#)
[AF Illuminator](#)
[Grid Line](#)
[Digital Zoom](#)
[Wind Noise Reduct.](#)
[Red Eye Reduction](#)
[Blink Alert](#)
[Write Date](#)

Main Settings

[Beep](#)
[Panel Brightness](#)
[Language Setting](#)
[Display color](#)
[Demo Mode](#)
[Initialize](#)
[Function Guide](#)
[CTRL FOR HDMI](#)
[USB Connect Setting](#)
[USB Power Supply](#)
[LUN Setting](#)
[Download Music](#)
[Empty Music](#)
[TransferJet](#)
[Eye-Fi](#)
[Power Save](#)

Memory Card Tool/Internal Memory Tool

[Format](#)
[Create REC.Folder](#)
[Change REC.Folder](#)
[Delete REC.Folder](#)
[Copy](#)
[File Number](#)

Clock Settings

[Area Setting](#)
[Date & Time Setting](#)

- ▶ Operation Search
- ▶ Before Use
- ▶ Shooting
- ▶ Viewing
- ▶ Using 3D Functions
- ▶ Using MENU items (Shooting)
- ▶ Using MENU items (Viewing)
- ▶ Changing settings
- ▶ Viewing images on a TV
- ▶ Using with your computer
- ▶ Printing
- ▶ Troubleshooting
- ▶ Precautions/About this camera

[➡ Contents list](#)

Viewing images on a TV

Viewing an image on a High Definition (HD) TV

[Viewing an image on an HD TV using the HDMI Cable \(sold separately\)](#)

Viewing an image on a “BRAVIA” Sync-compatible TV

[Viewing an image on a “BRAVIA” Sync-compatible TV](#)

Viewing an image on a Standard Definition (SD) TV

[Viewing an image on a Standard Definition \(SD\) TV](#)

[▲ Back to top](#)

- ▶ Operation Search
- ▶ Before Use
- ▶ Shooting
- ▶ Viewing
- ▶ Using 3D Functions
- ▶ Using MENU items (Shooting)
- ▶ Using MENU items (Viewing)
- ▶ Changing settings
- ▶ Viewing images on a TV
- ▶ Using with your computer
- ▶ Printing
- ▶ Troubleshooting
- ▶ Precautions/About this camera

[➡ Contents list](#)

Using with your computer

Recommended computer environment

[Recommended computer environment \(Windows\)](#)

[Recommended computer environment \(Macintosh\)](#)

Using the software

[“PMB \(Picture Motion Browser\)”](#)

[“Music Transfer”](#)

[Installing “PMB” and “Music Transfer” \(Windows\)](#)

[Installing “Music Transfer” \(Macintosh\)](#)

Connecting the camera to the computer

[Connecting the camera to the computer](#)

[Importing images to a computer \(Windows\)](#)

[Importing images to a computer \(Macintosh\)](#)

[Deleting the USB connection](#)

Uploading images to a media service

[“PMB Portable”](#)

[Starting up “PMB Portable” \(Windows\)](#)

[Starting up “PMB Portable” \(Macintosh\)](#)

Creating a disc of movies

[Selecting the method for creating a disc of movies](#)

[Creating AVCHD discs](#)

[Creating standard definition image quality \(STD\) discs](#)

[Creating Blu-ray discs](#)

[▲ Back to top](#)

- ▶ Operation Search
- ▶ Before Use
- ▶ Shooting
- ▶ Viewing
- ▶ Using 3D Functions
- ▶ Using MENU items (Shooting)
- ▶ Using MENU items (Viewing)
- ▶ Changing settings
- ▶ Viewing images on a TV
- ▶ Using with your computer
- ▶ Printing
- ▶ Troubleshooting
- ▶ Precautions/About this camera

[➡ Contents list](#)

Printing

Printing still images

[Printing still images](#)

[Printing at a shop](#)

[▲ Back to top](#)

- ▶ Operation Search
- ▶ Before Use
- ▶ Shooting
- ▶ Viewing
- ▶ Using 3D Functions
- ▶ Using MENU items (Shooting)
- ▶ Using MENU items (Viewing)
- ▶ Changing settings
- ▶ Viewing images on a TV
- ▶ Using with your computer
- ▶ Printing
- ▶ Troubleshooting
- ▶ Precautions/About this camera

[➡ Contents list](#)

Troubleshooting

If you have problems

[If you have problems](#)

Troubleshooting

- [Battery pack and power](#)
- [Shooting still images/movies](#)
- [Viewing images](#)
- [Deleting](#)
- [Computers](#)
- [Memory card](#)
- [Internal memory](#)
- [Printing](#)
- [Others](#)

Warning indicators and messages

- [Self-diagnosis display](#)
- [Messages](#)

[▲ Back to top](#)

- ▶ [Operation Search](#)
- ▶ [Before Use](#)
- ▶ [Shooting](#)
- ▶ [Viewing](#)
- ▶ [Using 3D Functions](#)
- ▶ [Using MENU items \(Shooting\)](#)
- ▶ [Using MENU items \(Viewing\)](#)
- ▶ [Changing settings](#)
- ▶ [Viewing images on a TV](#)
- ▶ [Using with your computer](#)
- ▶ [Printing](#)
- ▶ [Troubleshooting](#)
- ▶ [Precautions/About this camera](#)

[➡ Contents list](#)

Precautions/About this camera

Precautions

- [Precautions](#)
- [On the internal rechargeable backup battery](#)
- [Battery pack](#)
- [AC Adaptor](#)
- [Memory card](#)

On cleaning

- [On cleaning](#)

Number of still images and recordable time of movies

- [Number of still images](#)
- [Recordable time of movies](#)

Using the camera abroad

- [Using the camera abroad](#)
- [On TV color systems](#)

About this camera

- [Intelligent Pantiliter](#)
- [Carl Zeiss lens](#)
- [AVCHD format](#)
- [TransferJet standard](#)
- [License](#)

Trademarks

- [Trademarks](#)

[▲ Back to top](#)

- ▶ [Operation Search](#)
- ▶ [Before Use](#)
- ▶ [Shooting](#)
- ▶ [Viewing](#)
- ▶ [Using 3D Functions](#)
- ▶ [Using MENU items \(Shooting\)](#)
- ▶ [Using MENU items \(Viewing\)](#)
- ▶ [Changing settings](#)
- ▶ [Viewing images on a TV](#)
- ▶ [Using with your computer](#)
- ▶ [Printing](#)
- ▶ [Troubleshooting](#)
- ▶ [Precautions/About this camera](#)

[→ Contents list](#)

Contents list

Operation Search

Operation Search

[Search by Operation](#)

[▲ Back to top](#)

Before Use

How to use this User Guide

[How to use this User Guide](#)

[The images and illustrations used in this User Guide](#)

Names of parts and list of icons displayed on the screen

[Names of parts](#)

[List of icons displayed on the screen](#)

Using the wrist strap

[Using the wrist strap](#)

Using the control wheel

[Using the control wheel](#)

Using the internal memory

[Using the internal memory](#)

Using the In-Camera guide

[In-Camera Guide](#)

[▲ Back to top](#)

Shooting

Shooting still images

[Shooting still images](#)

[Zoom](#)

Shooting movies

[Shooting movies](#)

[Shooting still images while recording a movie \(Dual Rec\)](#)

Shooting panoramic images

[Shooting panoramic images](#)

Setting still image shooting mode

[List of mode switch functions](#)

[Intelligent Auto](#)

[Superior Auto](#)

Program Auto
3D Still Image
Scene Selection
Background Defocus
Functions not available in some REC modes

Using shooting functions

Tracking focus
DISP (Display Setting)
Flash
Burst Settings
Self-Timer

[▲ Back to top](#)

Viewing

Viewing still images

Viewing still images
Playback zoom
Image Index

Deleting images

Delete button

Viewing burst images

Viewing burst images

Viewing movies

Viewing movies

Viewing panorama images

Scrolling the panorama images for display

[▲ Back to top](#)

Using 3D Functions

3D Functions

3D Functions
File name of the 3D image

Shooting 3D images

3D Still Image
3D Sweep Panorama
Sweep Multi Angle

Viewing 3D images

Viewing images shot in Sweep Multi Angle mode stereoscopically
Viewing 3D images on a 3D TV

[▲ Back to top](#)

Using MENU items (Shooting)

Using MENU items (Shooting)

Using MENU items (Shooting)

MENU items (Shooting)

REC Mode
Movie shooting scene
Panorama Shooting Scene
Scene Selection
Easy Mode
Defocus Effect
Still Image Size/Panorama Image Size
Movie Quality/Movie Size
EV
ISO
White Balance
Focus
Metering Mode
Burst Shooting Interval
Scene Recognition
Soft Skin Effect
Smile Shutter
Smile Detection Sensitivity
Face Detection
Anti Blink
In-Camera Guide

Shooting MENU list

MENU items not available in some REC modes

[▲ Back to top](#)

Using MENU items (Viewing)

Using MENU items (Viewing)

Using MENU items (Viewing)

MENU items (Viewing)

Easy Mode
Slideshow
3D Viewing
Send by TransferJet
View Mode
Display Burst Group
Retouch
Delete
Protect
Print (DPOF)
Rotate
In-Camera Guide

Playback MENU list

MENU items that cannot be set according to View Mode

[▲ Back to top](#)

Changing settings

Changing settings

[Changing camera settings](#)

Shooting Settings

[Movie format](#)

[AF Illuminator](#)

[Grid Line](#)

[Digital Zoom](#)

[Wind Noise Reduct.](#)

[Red Eye Reduction](#)

[Blink Alert](#)

[Write Date](#)

Main Settings

[Beep](#)

[Panel Brightness](#)

[Language Setting](#)

[Display color](#)

[Demo Mode](#)

[Initialize](#)

[Function Guide](#)

[CTRL FOR HDMI](#)

[USB Connect Setting](#)

[USB Power Supply](#)

[LUN Setting](#)

[Download Music](#)

[Empty Music](#)

[TransferJet](#)

[Eye-Fi](#)

[Power Save](#)

Memory Card Tool/Internal Memory Tool

[Format](#)

[Create REC.Folder](#)

[Change REC.Folder](#)

[Delete REC.Folder](#)

[Copy](#)

[File Number](#)

Clock Settings

[Area Setting](#)

[Date & Time Setting](#)

[▲ Back to top](#)

Viewing images on a TV

Viewing an image on a High Definition (HD) TV

[Viewing an image on an HD TV using the HDMI Cable \(sold separately\)](#)

Viewing an image on a “BRAVIA” Sync-compatible TV

[Viewing an image on a “BRAVIA” Sync-compatible TV](#)

Viewing an image on a Standard Definition (SD) TV

[Viewing an image on a Standard Definition \(SD\) TV](#)

[▲ Back to top](#)

Using with your computer

Recommended computer environment

[Recommended computer environment \(Windows\)](#)

[Recommended computer environment \(Macintosh\)](#)

Using the software

[“PMB \(Picture Motion Browser\)”](#)

[“Music Transfer”](#)

[Installing “PMB” and “Music Transfer” \(Windows\)](#)

[Installing “Music Transfer” \(Macintosh\)](#)

Connecting the camera to the computer

[Connecting the camera to the computer](#)

[Importing images to a computer \(Windows\)](#)

[Importing images to a computer \(Macintosh\)](#)

[Deleting the USB connection](#)

Uploading images to a media service

[“PMB Portable”](#)

[Starting up “PMB Portable” \(Windows\)](#)

[Starting up “PMB Portable” \(Macintosh\)](#)

Creating a disc of movies

[Selecting the method for creating a disc of movies](#)

[Creating AVCHD discs](#)

[Creating standard definition image quality \(STD\) discs](#)

[Creating Blu-ray discs](#)

[▲ Back to top](#)

Printing

Printing still images

[Printing still images](#)

[Printing at a shop](#)

[▲ Back to top](#)

Troubleshooting

If you have problems

[If you have problems](#)

Troubleshooting

[Battery pack and power](#)

[Shooting still images/movies](#)

[Viewing images](#)

[Deleting](#)

[Computers](#)

[Memory card](#)

[Internal memory](#)

[Printing](#)

[Others](#)

Warning indicators and messages

[Self-diagnosis display](#)

[Messages](#)

[▲ Back to top](#)

Precautions/About this camera

Precautions

[Precautions](#)

[On the internal rechargeable backup battery](#)

[Battery pack](#)

[AC Adaptor](#)

[Memory card](#)

On cleaning

[On cleaning](#)

Number of still images and recordable time of movies

[Number of still images](#)

[Recordable time of movies](#)

Using the camera abroad

[Using the camera abroad](#)

[On TV color systems](#)

About this camera

[Intelligent Pantilter](#)

[Carl Zeiss lens](#)

[AVCHD format](#)

[TransferJet standard](#)

[License](#)

Trademarks

[Trademarks](#)

[▲ Back to top](#)

▶ Operation Search
▶ Before Use
▶ Shooting
▶ Viewing
▶ Using 3D Functions
▶ Using MENU items (Shooting)
▶ Using MENU items (Viewing)
▶ Changing settings
▶ Viewing images on a TV
▶ Using with your computer
▶ Printing
▶ Troubleshooting
▶ Precautions/About this camera

[➡ Contents list](#)

Search by Operation

Learning about the camera's functions

[In-Camera Guide](#)
[Function Guide](#)

Leaving the settings to the camera

[Intelligent Auto](#)
[Superior Auto](#)
[Scene Selection](#)

Shooting movies

[Shooting movies](#)
[Shooting still images while recording a movie \(Dual Rec\)](#)

Shooting 3D images

[3D Still Image](#)
[3D Sweep Panorama](#)
[Sweep Multi Angle](#)

Shooting portraits

[Scene Selection\(Soft Skin\)](#)
[Scene Selection\(Soft Snap\)](#)
[Scene Selection\(Twilight Portrait\)](#)
[Smile Shutter](#)
[Face Detection](#)
[Anti Blink](#)
[Red Eye Reduction](#)

Shooting panoramic images

[Shooting panoramic images](#)

Shooting moving objects

[Movie shooting scene](#)
[Tracking focus](#)
[Burst Settings](#)

Shooting without blur

[Scene Selection\(Anti Motion Blur\)](#)
[Scene Selection\(Hand-held Twilight\)](#)
[Scene Selection\(High Sensitivity\)](#)
[Self-Timer\(2sec\)](#)
[ISO](#)

Shooting with backlight

[Superior Auto](#)
[Scene Selection\(Backlight Correction HDR\)](#)
[Flash\(On\)](#)

Shooting in dark places

[Scene Selection\(Hand-held Twilight\)](#)

Scene Selection(High Sensitivity)
Flash(Slow Synchro)
ISO

Changing focus position

Focus
Face Detection

Changing image size

Still Image Size/Panorama Image Size
Movie Quality/Movie Size

Changing screen display

DISP (Display Setting)
Display color

Deleting images

Delete button
Format

Displaying enlarged images

Playback zoom
Retouch(Trimming (Resize))

Editing images

Retouch

Playing back a series of images in order

Slideshow

Printing images with the date

Write Date

Changing clock settings

Area Setting
Date & Time Setting

Initializing settings

Initialize

Printing images

Printing still images

Viewing on TVs

Viewing 3D images on a 3D TV
Viewing an image on an HD TV using the HDMI Cable (sold separately)
Viewing an image on a Standard Definition (SD) TV

Creating a movie disc

Creating AVCHD discs

- ▶ Operation Search
- ▶ Before Use
- ▶ Shooting
- ▶ Viewing
- ▶ Using 3D Functions
- ▶ Using MENU items (Shooting)
- ▶ Using MENU items (Viewing)
- ▶ Changing settings
- ▶ Viewing images on a TV
- ▶ Using with your computer
- ▶ Printing
- ▶ Troubleshooting
- ▶ Precautions/About this camera

➡ Contents list

How to use this User Guide

- ▼ Selecting a topic to display
- ▼ Returning to a previous page
- ▼ Printing out a page
- ▼ Marks and notations used in this User Guide

This User Guide explains how to use each function of the camera, how to change settings, and how to troubleshoot a problem.

Selecting a topic to display

The following illustrations take Internet Explorer 7 as an example.

1. Click a title in the side bar on the left of the browser window.
The title's topic list appears in the right pane.
2. Click a topic title in the list.

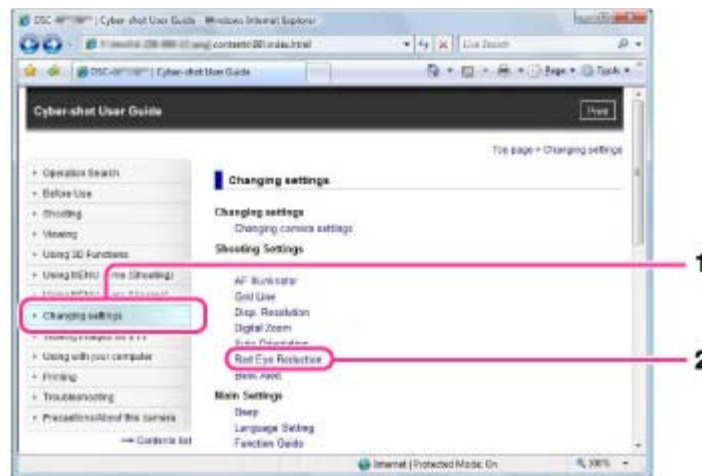

Descriptions appear in the right pane.

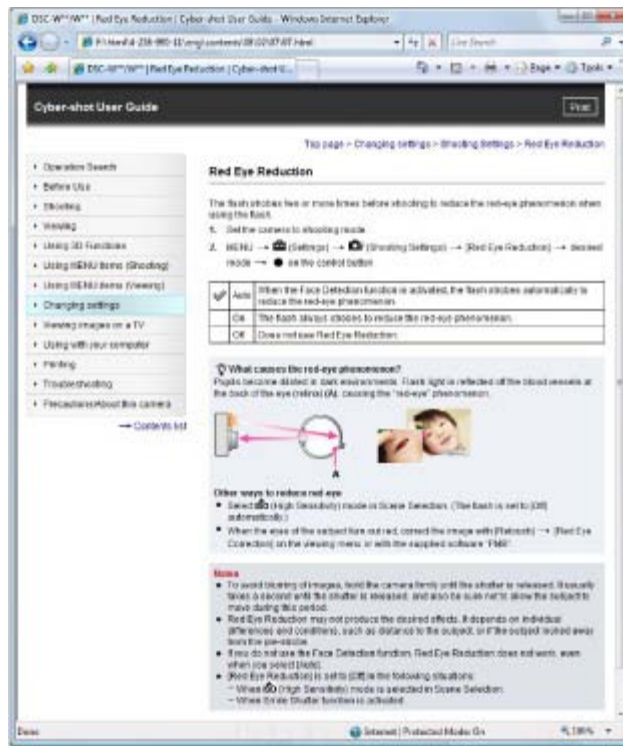

Changing the font size

Change the font size by changing the setting of your web browser. For how to change the font size setting, refer to the Help of your web browser.

Returning to a previous page

Use the back button of your web browser or the breadcrumb trail navigation to return to a page you previously viewed.

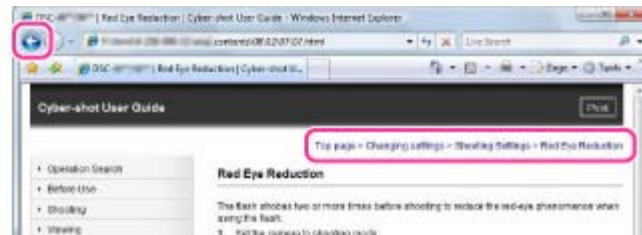

Printing out a page

Click the [Print] button to print out a page you are viewing.



Marks and notations used in this User Guide

In this User Guide, the sequence of operations is shown by arrows (→) (A). Operate the camera in the order indicated.

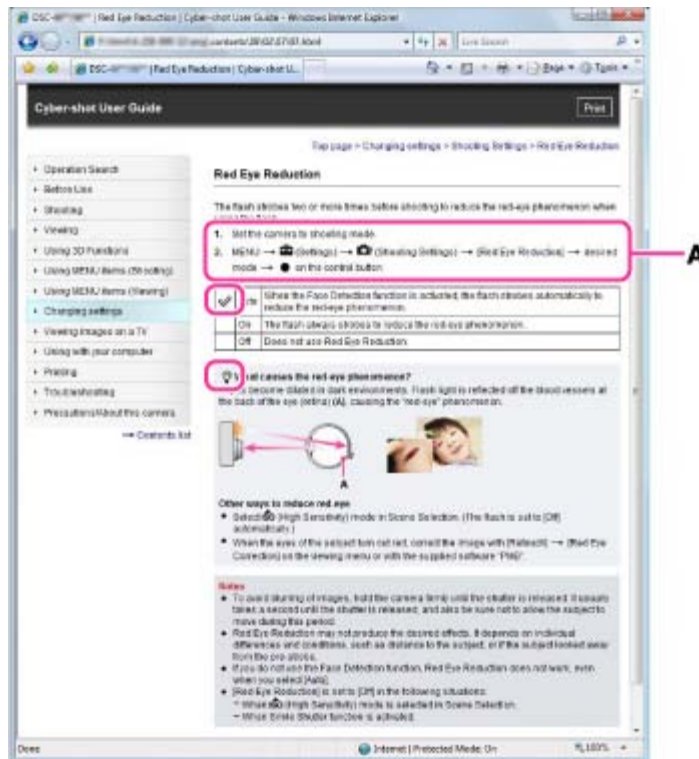

- Icons in the operating procedure sentences appear when the camera is in its default settings.
- The default setting is indicated by ✓.
- 💡 indicates information that is useful to know.

▲ [Back to top](#)

[Top page](#) > [Before Use](#) > [How to use this User Guide](#) > [The images and illustrations used in this User Guide](#)

The images and illustrations used in this User Guide

Images used in this User Guide

- The images used as examples in this User Guide are reproduced images, and are not actual images shot using this camera.

Illustrations used in this User Guide

- Illustrations used in this User Guide are of the DSC-WX7 unless noted otherwise.

[▲ Back to top](#)

▶ Operation Search
▶ Before Use
▶ Shooting
▶ Viewing
▶ Using 3D Functions
▶ Using MENU items (Shooting)
▶ Using MENU items (Viewing)
▶ Changing settings
▶ Viewing images on a TV
▶ Using with your computer
▶ Printing
▶ Troubleshooting
▶ Precautions/About this camera

[➡ Contents list](#)

Copyright 2011 Sony Corporation

- ▶ Operation Search
- ▶ Before Use
- ▶ Shooting
- ▶ Viewing
- ▶ Using 3D Functions
- ▶ Using MENU items (Shooting)
- ▶ Using MENU items (Viewing)
- ▶ Changing settings
- ▶ Viewing images on a TV
- ▶ Using with your computer
- ▶ Printing
- ▶ Troubleshooting
- ▶ Precautions/About this camera

[→ Contents list](#)

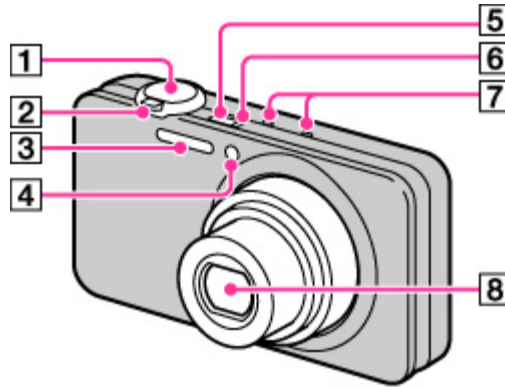

Names of parts

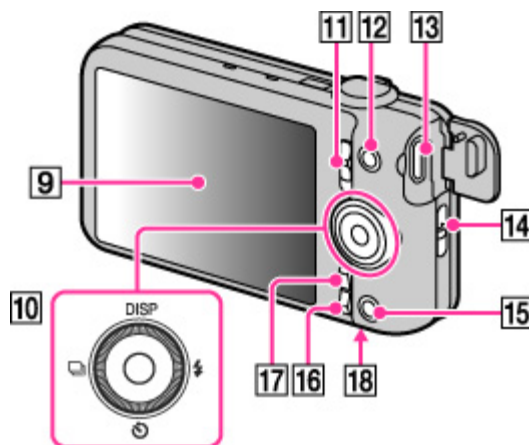

- 1** Shutter button
- 2** For shooting: W/T (zoom) lever
For viewing: (Playback zoom) lever/ (Index) lever
- 3** Flash
- 4** Self-timer lamp/Smile Shutter lamp/AF illuminator
- 5** ON/OFF (Power) button
- 6** Power/Charge lamp
- 7** Microphone
- 8** Lens



- 9** LCD screen
- 10** Control wheel
- 11** Mode switch

- 12 MOVIE (Movie) button
- 13 HDMI connector
- 14 Hook for wrist strap
- 15  (Playback) button
- 16  (In-Camera Guide/Delete) button
- 17 MENU button
- 18  (TransferJet™) mark

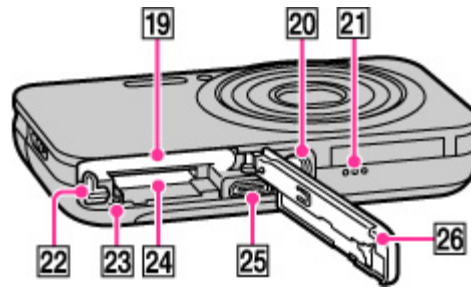

- 19 Battery insertion slot
- 20 Tripod receptacle
- 21 Speaker
- 22 Battery eject lever
- 23 Access lamp
- 24 Memory card slot
- 25 Multi connector (Type3b)
- 26 Battery/Memory card cover

[▲ Back to top](#)

Top page > Before Use > Names of parts and list of icons displayed on the screen > List of icons displayed on the screen

List of icons displayed on the screen

▼ List of shooting mode icons

▼ List of viewing mode icons

Icons are displayed on the screen to indicate the camera status.

You can change the screen display using **DISP** (Display Setting) on the control wheel.

List of shooting mode icons

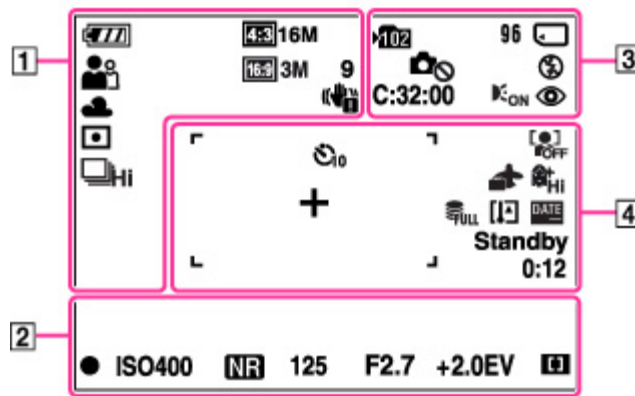





1





Display	Indication
	Battery remaining
	Low battery warning
	Image size/Panorama image size/Quality
9	Number of recordable images (Dual Rec)
	Scene Selection
	Shooting mode
	Scene Recognition icon
	White balance
	Metering Mode
	Vibration warning
	Anti Blink
	Scene Recognition

- ▶ Operation Search
- ▶ Before Use
- ▶ Shooting
- ▶ Viewing
- ▶ Using 3D Functions
- ▶ Using MENU items (Shooting)
- ▶ Using MENU items (Viewing)
- ▶ Changing settings
- ▶ Viewing images on a TV
- ▶ Using with your computer
- ▶ Printing
- ▶ Troubleshooting
- ▶ Precautions/About this camera









→ Contents list

	Overlay icon for Superior Auto
	Burst Shooting Interval
	Smile Detection Sensitivity indicator
	Zoom scaling

2

Display	Indication
	AE/AF lock
ISO400	ISO number
	NR slow shutter
125	Shutter speed
F2.7	Aperture value
	Wind Noise Reduction
+2.0EV	Exposure value
	AF range finder frame indicator

3

Display	Indication
	Recording folder
96	Number of recordable images
	Buffer writing
CAPTURE	Capture
100Min	Recordable time
	Recording Media (Memory card, internal memory)
	Warning indicator pertaining to still image recording
	Flash mode
C:32:00	Self-diagnosis display
	AF Illuminator
	Red-eye reduction
	Defocus Effect
	Flash charging

4

Display	Indication
	Self-timer
	Face detection
	Destination
	Soft Skin Effect
	Database file full/Database file error
	Overheating warning
	Write Date
	AF range finder frame
	Spot metering cross-hairs
	Histogram
REC Standby	Recording a movie/Movie standby
0:12	Recording time (m:s)

List of viewing mode icons

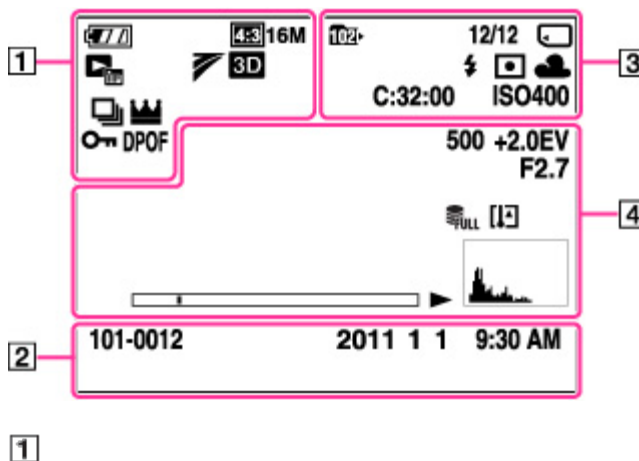







Display	Indication
	Battery remaining
	Low battery warning
	Image size/Panorama image size/Quality
	View mode
	TransferJet settings
	3D images
	Burst Images
	Main image in the burst group
	Protect

DPOF	Print order (DPOF)
Qx2.0	Playback zoom









2

Display	Indication
101-0012	Folder-file number
2011 1 1 9:30 AM	Recorded date/time of the playback image

3

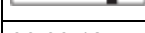
Display	Indication
	Playback folder
12/12	Image number/Number of images recorded in selected date range, folder
	Playback Media (Memory card, internal memory)
	Eye-Fi Mode display
	Flash mode
	Metering Mode
	White balance
C:32:00	Self-diagnosis display
ISO400	ISO number

4

Display	Indication
500	Shutter speed
+2.0EV	Exposure value
F2.7	Aperture value
	Database file full/Database file error
	Overheating warning
	Playback
	Variable speed playback
	Playback bar
00:00:12	Counter
	Histogram •  appears when histogram display is disabled.
	Volume

- ▶ Operation Search
- ▶ **Before Use**
- ▶ Shooting
- ▶ Viewing
- ▶ Using 3D Functions
- ▶ Using MENU items (Shooting)
- ▶ Using MENU items (Viewing)
- ▶ Changing settings
- ▶ Viewing images on a TV
- ▶ Using with your computer
- ▶ Printing
- ▶ Troubleshooting
- ▶ Precautions/About this camera

[➔ Contents list](#)

Using the wrist strap

Attach the strap and place your hand through the loop to prevent the camera from damage by being dropped.

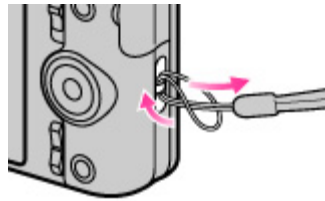

[▲ Back to top](#)

- ▶ Operation Search
- ▶ Before Use
- ▶ Shooting
- ▶ Viewing
- ▶ Using 3D Functions
- ▶ Using MENU items (Shooting)
- ▶ Using MENU items (Viewing)
- ▶ Changing settings
- ▶ Viewing images on a TV
- ▶ Using with your computer
- ▶ Printing
- ▶ Troubleshooting
- ▶ Precautions/About this camera

[→ Contents list](#)

Using the control wheel

- ▼ Moving the selection frame on MENU screen, etc.
- ▼ Selecting an image to be played back
- ▼ Selecting a REC mode

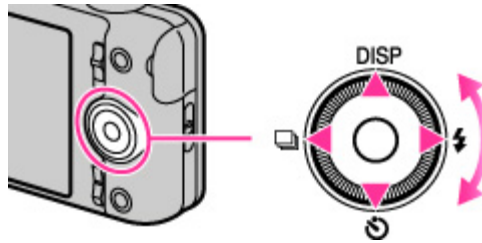

The following functions are located on the up/down/right/left side of the control wheel: **DISP** (Display Setting), (Flash), (Self-Timer) and (Burst Settings). Press the control wheel toward each icon to enter the setup screen for each function.

Turn the control wheel or press the up/down/right/left side of the wheel following the screen to move the selection frame.

Press in the center of the control wheel to set the selected item.

Moving the selection frame on MENU screen, etc.

Turn the control wheel or press the up/down/right/left side of the wheel to move the selection frame. In some modes, you can also move the selection frame by turning the control wheel.

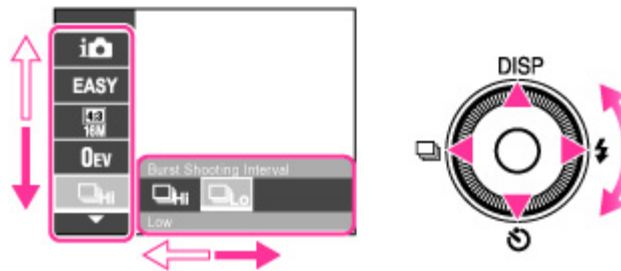

Selecting an image to be played back

Press the right or left side of the control wheel, or turn the wheel to play back the next/previous image.

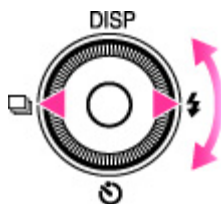

■ Selecting a REC mode

Turn the control wheel to display the REC mode selection screen.
Keep turning the control wheel until the desired mode is selected.
The available modes differ depending on the position of the mode switch.

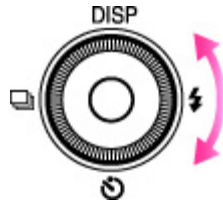

- You can also change the REC mode from [MENU].

[▲ Back to top](#)

Copyright 2011 Sony Corporation

▶ Operation Search
▶ Before Use
▶ Shooting
▶ Viewing
▶ Using 3D Functions
▶ Using MENU items (Shooting)
▶ Using MENU items (Viewing)
▶ Changing settings
▶ Viewing images on a TV
▶ Using with your computer
▶ Printing
▶ Troubleshooting
▶ Precautions/About this camera

[→ Contents list](#)

Using the internal memory

▼ On image data stored in the internal memory

The camera has approximately 19 MB of internal memory. This memory is not removable. You can record still images on the internal memory when there is no memory card inserted in the camera.

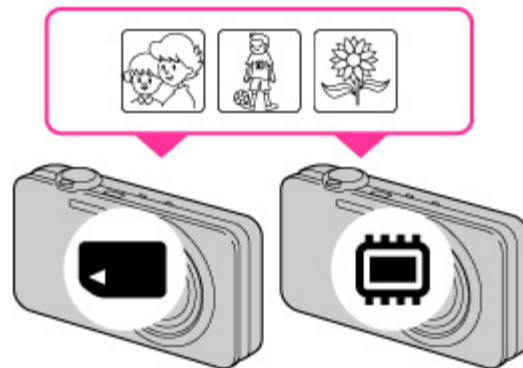

When a memory card is inserted

[Recording]: Images are recorded on the memory card.

[Playback]: Images on the memory card are played back.

[Menu, Settings, etc.]: Various functions can be performed on images on the memory card.

When there is no memory card inserted

[Recording]: Images are recorded using the internal memory. However, movies cannot be recorded to the internal memory.

[Playback]: Images stored in the internal memory are played back.

[Menu, Settings, etc.]: Various functions can be performed on images in the internal memory.

■ On image data stored in the internal memory

We recommend that you copy (back up) data using one of the following methods.

To copy (back up) data on a hard disk of your computer

Without a memory card inserted in the camera, import the images into a computer. [\[Details\]](#)
[\[Details\]](#)

To copy (back up) data on a memory card

Prepare a memory card with sufficient free capacity, then copy the images in the internal memory to the memory card. [\[Details\]](#)

Notes

- You cannot transfer image data on a memory card to the internal memory.
- By making a USB connection between the camera and a computer with a multi-use terminal USB cable, you can transfer data stored in the internal memory to a computer. However you cannot transfer data on a computer to the internal memory.

- ▶ Operation Search
- ▶ Before Use
- ▶ Shooting
- ▶ Viewing
- ▶ Using 3D Functions
- ▶ Using MENU items (Shooting)
- ▶ Using MENU items (Viewing)
- ▶ Changing settings
- ▶ Viewing images on a TV
- ▶ Using with your computer
- ▶ Printing
- ▶ Troubleshooting
- ▶ Precautions/About this camera

[→ Contents list](#)

In-Camera Guide

This camera contains an internal function guide. This allows you to search the camera's functions according to your needs.

You can use the selected function after reading the guide.

1. Press the  (In-Camera Guide) button.
 When shooting images:
 [In-Camera Guide] search methods are displayed.
 When viewing images:
 [Delete/In-Camera Guide] are displayed.
 Select [In-Camera Guide].
2. Select a search method.

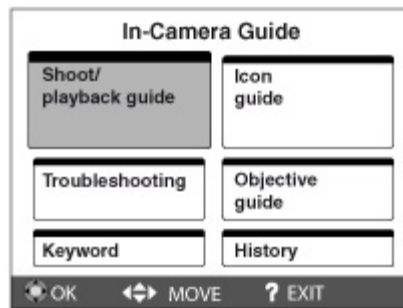

Search method	Description
Shoot/ playback guide	Search for various operation functions in shooting/viewing mode.
Icon guide	Search the function and meaning of displayed icons.
Troubleshooting	Search common problems and their solution.
Objective guide	Search functions according to your needs.
Keyword	Search functions by key words.
History	Display the last 12 items displayed in [In-Camera Guide].

An operation guide is displayed so that you can operate the camera following the instructions on the screen.

This is explained in [Shoot/ playback guide].

3. Select the desired mode.



Functions available in the selected function is displayed.

4. Select the desired function, then press ● on the control wheel.
The operation guide for the selected function is displayed.



5. Use ▲ / ▼ to switch the display from summary to operation to details.
 - The operation guide and details may not be displayed, depending on the selected function.
 - When you select [Use this function], the camera switches to the selected mode automatically.
6. To end [In-Camera Guide], press ?/🗑️ (In-Camera Guide) button.

Notes

- ?/🗑️ (In-Camera Guide) button is not available in the following situations:
 - In movie mode
 - In Intelligent Sweep Panorama mode
 - In Easy Mode
- [Use this function] may not be available, depending on the selected functions.

[▲ Back to top](#)

- ▶ Operation Search
- ▶ Before Use
- ▶ Shooting
- ▶ Viewing
- ▶ Using 3D Functions
- ▶ Using MENU items (Shooting)
- ▶ Using MENU items (Viewing)
- ▶ Changing settings
- ▶ Viewing images on a TV
- ▶ Using with your computer
- ▶ Printing
- ▶ Troubleshooting
- ▶ Precautions/About this camera

[→ Contents list](#)

Shooting still images

1. Set the mode switch to  (Still Image), then press the ON/OFF (Power) button.

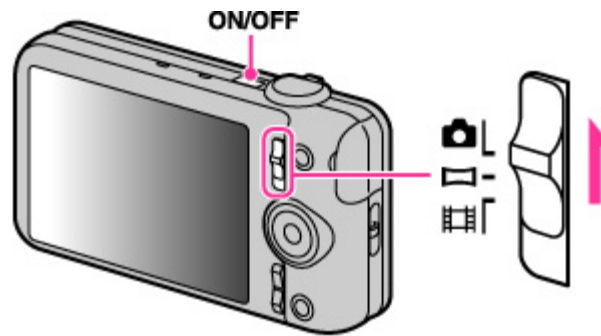

2. Hold the camera steady as illustrated.



3. Press the shutter button halfway down to focus.
When the image is in focus, a beep sounds and the  indicator lights.



- The shortest shooting distance is approximately 5 cm (2 inches) (W), 1 m (3 ft 3 3/8 inches) (T) (from the lens).

4. Press the shutter button fully down.



If you shoot a still image of a subject that is difficult to focus on

- When the camera cannot focus on the subject automatically, the AE/AF lock indicator changes to slowly flashing and the beep does not sound. Either recompose the shot or change the focus setting. [\[Details\]](#)

- Focusing may be difficult in the following situations:
 - It is dark and the subject is distant.
 - The contrast between the subject and the background is poor.
 - The subject is seen through glass.
 - The subject is moving quickly.
 - There is reflective light or shiny surfaces.
 - The subject is backlit or there is a flashing light.

Related Topic

[Viewing still images](#)

[Still Image Size/Panorama Image Size](#)

[▲ Back to top](#)

Copyright 2011 Sony Corporation

▶ Operation Search
▶ Before Use
▶ Shooting
▶ Viewing
▶ Using 3D Functions
▶ Using MENU items (Shooting)
▶ Using MENU items (Viewing)
▶ Changing settings
▶ Viewing images on a TV
▶ Using with your computer
▶ Printing
▶ Troubleshooting
▶ Precautions/About this camera

[→ Contents list](#)

Zoom

You can enlarge the image when shooting. The camera's optical zoom function can enlarge images up to 5×.

1. Turn the W/T (zoom) lever.

Turn the W/T (zoom) lever to T side to zoom in, W side to zoom out.



- When the zoom scale exceeds 5×, set [Digital Zoom]. [\[Details\]](#)

Note

- Zoom is locked to the W side in the following situations:
 - In Intelligent Sweep Panorama mode
 - In 3D Sweep Panorama mode
 - In Sweep Multi Angle mode

[▲ Back to top](#)

▶ Operation Search
▶ Before Use
▶ Shooting
▶ Viewing
▶ Using 3D Functions
▶ Using MENU items (Shooting)
▶ Using MENU items (Viewing)
▶ Changing settings
▶ Viewing images on a TV
▶ Using with your computer
▶ Printing
▶ Troubleshooting
▶ Precautions/About this camera

[→ Contents list](#)

Shooting movies

1. Set the mode switch to  (Movie), then press the ON/OFF (Power) button.

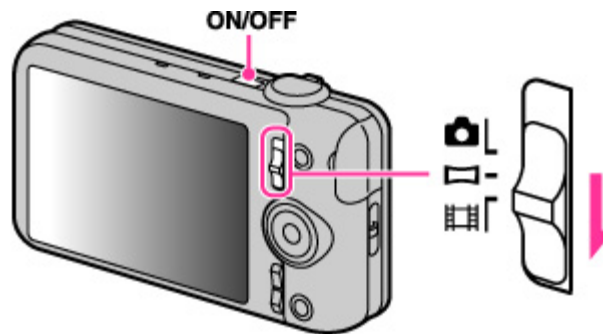

2. Press the MOVIE (Movie) button to start recording.

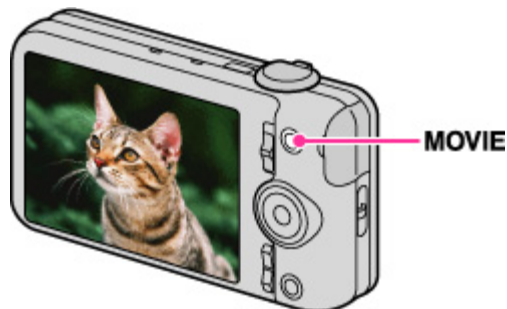

3. Press the MOVIE button again to stop recording.

MOVIE (Movie) button

You can start recording a movie by pressing the MOVIE button, regardless of the position of the mode switch.

Notes

- The sound of the lens and lever operating will be recorded when the zoom function operates while shooting a movie. The sound of the MOVIE button operating may also be recorded when you press the MOVIE button to stop recording.
- Continuous shooting is possible for approximately 29 minutes at one time at the camera's default settings and when the temperature is approximately 25°C(77°F). When movie recording is finished, you can restart recording by pressing the MOVIE button again. Recording may stop to protect the camera depending on the ambient temperature.

Related Topic

[Zoom](#)

[Shooting still images while recording a movie \(Dual Rec\)](#)

[Movie Quality/Movie Size](#)

[Movie format](#)

[Top page](#) > [Shooting](#) > [Shooting movies](#) > [Shooting still images while recording a movie \(Dual Rec\)](#)

Shooting still images while recording a movie (Dual Rec)

You can shoot still images while recording a movie. The camera keeps recording the movie even if you shoot still images.

Up to 10 still images can be shot during one movie recording.

1. Press the MOVIE (Movie) button to start recording a movie.

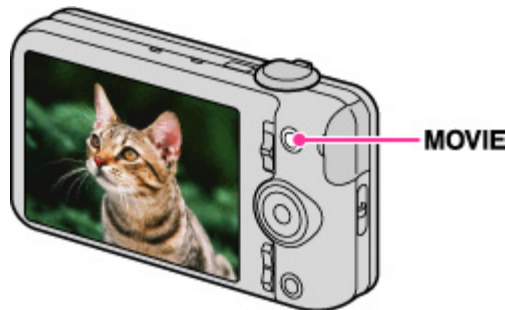

2. Press the shutter button.

A still image is recorded.

- The number of recordable still images (**A**) appears on the LCD screen when you press the shutter button halfway down.



3. Press the MOVIE button to stop recording the movie.

After recording movies, the recorded still images are displayed in frames on the LCD screen.

Notes

- The sound of the shutter button operating may be recorded.
- Flash is not available for shooting still images during movie recording.
- The image size of still images is fixed to [16:9 (3M)]. If the movie image size is set to [MP4 3M], the still image size is fixed to [4:3 (2M)].
- When the Smile Shutter function is set to [On], the shutter releases automatically each time the camera detects a smiling face. You cannot switch [On] or [Off] for Smile Shutter during movie recording.
- If the memory card capacity is insufficient or 10 images have been shot,  appears on the screen. This icon indicates that no more still images can be shot.

- ▶ Operation Search
- ▶ Before Use
- ▶ Shooting
- ▶ Viewing
- ▶ Using 3D Functions
- ▶ Using MENU items (Shooting)
- ▶ Using MENU items (Viewing)
- ▶ Changing settings
- ▶ Viewing images on a TV
- ▶ Using with your computer
- ▶ Printing
- ▶ Troubleshooting
- ▶ Precautions/About this camera

[→ Contents list](#)

[▲ Back to top](#)

- ▶ Operation Search
- ▶ Before Use
- ▶ Shooting
- ▶ Viewing
- ▶ Using 3D Functions
- ▶ Using MENU items (Shooting)
- ▶ Using MENU items (Viewing)
- ▶ Changing settings
- ▶ Viewing images on a TV
- ▶ Using with your computer
- ▶ Printing
- ▶ Troubleshooting
- ▶ Precautions/About this camera

[→ Contents list](#)

Shooting panoramic images

Allows you to create a panoramic image from composite images. The camera also automatically detects people's faces or moving subjects.



1. Set the mode switch to  (Sweep Panorama), then press the ON/OFF (Power) button.

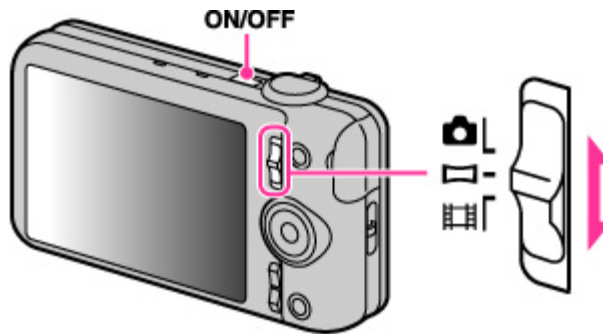

2. Select a shooting direction using  /  /  /  on the control wheel.

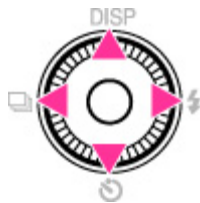

- ▲ Pan the camera from down to up
- ▼ Pan the camera from up to down
- ▶ Pan the camera from left to right
- ◀ Pan the camera from right to left

3. Align the camera with the end of the subject to be shot and press the shutter button fully.



- A black, translucent portion (A) appears before shooting. That part will not be recorded.

4. Pan the camera to the end of the guide (B), following the indication on the LCD screen.

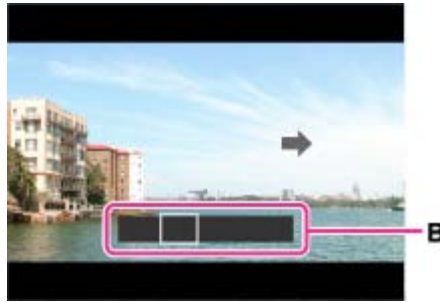

Shooting a high-resolution panoramic image

If you set [Panorama Image Size] to [High Resolution], a 43 megapixel-size panoramic image (10480×4096) can be shot.

- 1 Hold the camera vertically.



- 2 Select a shooting direction using the control wheel.

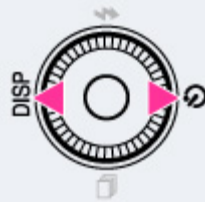

- 3 Pan the camera to shoot.

Tips for shooting a panorama image

Pan the camera in an arc at a constant velocity in the direction indicated on the LCD screen. Subjects at rest are more suited for panorama shots than moving subjects. Radius as short as possible.

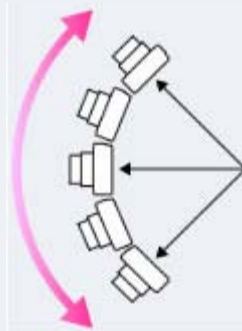

Vertical direction

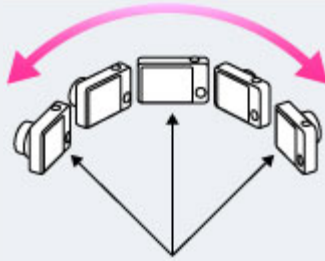

Horizontal direction

- First, press the shutter button halfway so that you can lock the focus, exposure and white balance. Then, press the shutter button fully down and pan or tilt the camera.
- If a section with greatly varied shapes or scenery is concentrated along a screen edge, the image composition may fail. In such case, adjust the frame composition so that the section is in the center of the image, then shoot again.

Notes

- If you cannot pan the camera across the entire subject within the given time, a gray area occurs in the composite image. If this happens, move the camera faster to record a full panorama image.
- Since several images are stitched together, the stitched part will not be recorded smoothly.
- Under low light conditions, panorama images may be blurred or the shooting may not be successful.
- Under lights that flicker, such as fluorescent lights, the brightness or color of the combined image will not always be the same.
- When the whole angle of panoramic shooting and the AE/AF locked angle are very different in brightness, color and focus, the shooting will not be successful. If this happens, change AE/AF locked angle and shoot again.
- Sweep Panorama is not suitable for the following situations:
 - Moving subjects
 - Subjects are too close to the camera
 - Images with little contrast, such as sky, sandy beach or lawn
 - Images with constant changes, such as waves or waterfalls
- You cannot create panorama images in the following situations:
 - You pan the camera too quickly or too slowly.
 - There is too much camera shake.
- You may not be able to set some functions or MENU items depending on the selected REC mode. For details, see “Functions not available in some REC modes” [\[Details\]](#) and “MENU items not available in some REC modes.” [\[Details\]](#)

Related Topic

[Scrolling the panorama images for display](#)

[Panorama Shooting Scene](#)

[Still Image Size/Panorama Image Size](#)

[▲ Back to top](#)



- ▶ Operation Search
- ▶ Before Use
- ▶ Shooting
- ▶ Viewing
- ▶ Using 3D Functions
- ▶ Using MENU items (Shooting)
- ▶ Using MENU items (Viewing)
- ▶ Changing settings
- ▶ Viewing images on a TV
- ▶ Using with your computer
- ▶ Printing
- ▶ Troubleshooting
- ▶ Precautions/About this camera

[→ Contents list](#)

List of mode switch functions

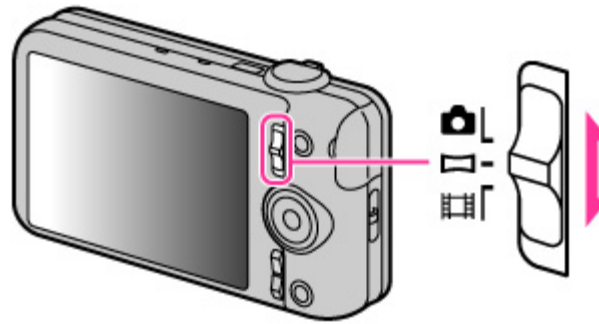
Set the mode switch to the desired function.



 (Still Image)	Allows you to shoot still images. [Details]
 (Sweep Panorama)	Allows you to shoot a panorama image by composing images. [Details]
 (Movie)	Allows you to change the settings for movie recording. [Details]

Related Topic

- [Intelligent Auto](#)
- [Program Auto](#)
- [Scene Selection](#)
- [Shooting panoramic images](#)
- [Shooting movies](#)



[▲ Back to top](#)

▶ Operation Search
▶ Before Use
▶ Shooting
▶ Viewing
▶ Using 3D Functions
▶ Using MENU items (Shooting)
▶ Using MENU items (Viewing)
▶ Changing settings
▶ Viewing images on a TV
▶ Using with your computer
▶ Printing
▶ Troubleshooting
▶ Precautions/About this camera

[→ Contents list](#)

Intelligent Auto

Allows you to shoot still images with the setting adjusted automatically.

1. Set the mode switch to  (Still Image).
2. Turn the control wheel to select  (Intelligent Auto). [\[Details\]](#)
3. Shoot with the shutter button.

Note













- You may not be able to set some functions depending on the selected REC mode. For details, see “Functions not available in some REC modes” [\[Details\]](#) and “MENU items not available in some REC modes.” [\[Details\]](#)

On Scene Recognition

Scene Recognition operates in Intelligent Auto mode. This function lets the camera automatically recognize the shooting conditions and shoot the image.



In Scene Recognition, the position of an icon displayed on the LCD screen is different depending on the circumstances. It depends on whether the camera recognizes a scene or condition.

If the camera recognizes a scene, icons and guides such as  (Portrait),  (Infant),  (Twilight Portrait),  (Twilight),  (Backlight Portrait),  (Backlight),  (Landscape),  (Macro),  (Spotlight) or  (Low Light), are displayed on the first line. If the camera recognizes a condition, icons such as  (Tripod) or  (Move) are displayed on the second line. The camera may recognize both the scene and condition, or just one.

Related Topic

[Scene Recognition](#)



[▲ Back to top](#)

- ▶ Operation Search
- ▶ Before Use
- ▶ Shooting
- ▶ Viewing
- ▶ Using 3D Functions
- ▶ Using MENU items (Shooting)
- ▶ Using MENU items (Viewing)
- ▶ Changing settings
- ▶ Viewing images on a TV
- ▶ Using with your computer
- ▶ Printing
- ▶ Troubleshooting
- ▶ Precautions/About this camera

[→ Contents list](#)

Superior Auto

The camera combines Scene Recognition and high-quality image technology to automatically shoot the images with the optimal settings.







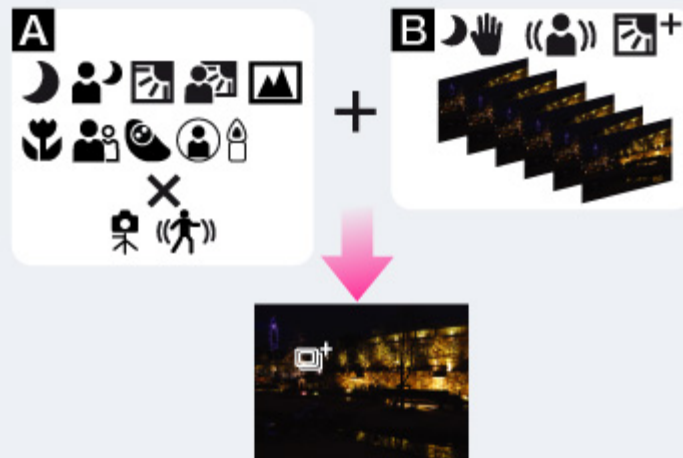





1. Set the mode switch to  (Still Image).
2. Turn the control wheel to select  (Superior Auto). [\[Details\]](#)
3. Shoot with the shutter button.
The camera shoots burst images when needed and overlays the multiple images. By overlaying the images, the camera records an image with less subject blur and noises.

What is the difference between Superior Auto mode and Intelligent Auto mode?

In Superior Auto mode, the camera shoots burst images based on the recognized scene, then creates a composite of the burst images (Overlay shooting). The camera automatically corrects the backlight and reduces the noise by overlaying images, so a higher-quality image results than in Intelligent Auto mode.



A : Scene Recognition

-  Twilight
-  Twilight Portrait
-  Backlight
-  Backlight Portrait
-  Landscape
-  Macro
-  Portrait
-  Infant
-  Spotlight
-  Low Light
-  Tripod
-  Move

B : Overlaying processing

-  Hand-held Twilight



Anti Motion Blur



Backlight Correction HDR

- The camera automatically selects an overlaying mode based on the recognized scene, and the  (overlay) appears on the LCD screen.

Notes

- When the camera overlays the images, it takes more time to record an image.
- In low light conditions such as night scenes, set [Flash] to [Off] to achieve the optimal effect of the overlaid images.
- The effect of reduced noise is less effective in the following situations:
 - Subjects are moving
 - Subjects are too close to the camera
 - Images with little contrast, such as sky, sandy beach or lawn
 - Images with constant changes, such as waves or waterfalls
- You may not be able to set some functions or MENU items depending on the selected REC mode. For details, see “Functions not available in some REC modes” [\[Details\]](#) and “MENU items not available in some REC modes.” [\[Details\]](#)

Related Topic

[Scene Recognition](#)

[▲ Back to top](#)

Copyright 2011 Sony Corporation

▶ Operation Search
▶ Before Use
▶ Shooting
▶ Viewing
▶ Using 3D Functions
▶ Using MENU items (Shooting)
▶ Using MENU items (Viewing)
▶ Changing settings
▶ Viewing images on a TV
▶ Using with your computer
▶ Printing
▶ Troubleshooting
▶ Precautions/About this camera

[➡ Contents list](#)

Program Auto

Allows you to shoot with the exposure adjusted automatically (both the shutter speed and the aperture value). Also you can select various settings using the menu.

1. Set the mode switch to  (Still Image).
2. Turn the control wheel to select **P** (Program Auto). [\[Details\]](#)
3. Shoot with the shutter button.

Note

- You may not be able to set some functions or MENU items depending on the selected REC mode. For details, see “Functions not available in some REC modes” [\[Details\]](#) and “MENU items not available in some REC modes.” [\[Details\]](#)



[▲ Back to top](#)

▶ Operation Search
▶ Before Use
▶ Shooting
▶ Viewing
▶ Using 3D Functions
▶ Using MENU items (Shooting)
▶ Using MENU items (Viewing)
▶ Changing settings
▶ Viewing images on a TV
▶ Using with your computer
▶ Printing
▶ Troubleshooting
▶ Precautions/About this camera

[➡ Contents list](#)

3D Still Image

Shooting a 3D image.

1. Set the mode switch to  (Still Image).
2. Turn the control wheel to select  (3D Still Image). [\[Details\]](#)
3. Shoot with the shutter button.

Tips for various 3D shooting

In addition to [3D Still Image], this camera also includes other modes for creating stereoscopic images, such as [3D Sweep Panorama] and [Sweep Multi Angle]. For details, see “3D Functions.” [\[Details\]](#)

[▲ Back to top](#)









- ▶ Operation Search
- ▶ Before Use
- ▶ Shooting
- ▶ Viewing
- ▶ Using 3D Functions
- ▶ Using MENU items (Shooting)
- ▶ Using MENU items (Viewing)
- ▶ Changing settings
- ▶ Viewing images on a TV
- ▶ Using with your computer
- ▶ Printing
- ▶ Troubleshooting
- ▶ Precautions/About this camera













[→ Contents list](#)







Scene Selection

Allows you to shoot with preset settings according to the scene.



1. Set the mode switch to  (Still Image).
2. Turn the control wheel to select **SCN** (Scene Selection). [\[Details\]](#)
 - If you want to select the other Scene Selection mode, select from MENU.

 (Soft Skin)	<p>Allows you to shoot faces for smoothness.</p> 
 (Soft Snap)	<p>Allows you to shoot images with a softer atmosphere for portraits and flowers, etc.</p> 
 (Anti Motion Blur)	<p>Allows you to shoot indoor shots without using the flash to reduce subject blur.</p> 
 (Landscape)	<p>Allows easy shooting of distant scenes by focusing in the distance. Shoots vivid blue sky and flora colors.</p> 
 (Backlight)	<p>Allows you to shoot three images having different exposures to create a single image with a greater range of gradation. The camera combines the dark parts of an image taken with a bright exposure setting and the bright parts of an image taken with a dark exposure setting.</p>

Correction HDR)	
 (Twilight Portrait)	<p>Allows you to shoot sharp images of people with the night view in the background without compromising the atmosphere.</p> 
 (Twilight)	<p>Allows you to shoot night scenes at far distance without losing the dark atmosphere of the surroundings.</p> 
 (Hand- held Twilight)	<p>Allows you to shoot night scenes with less noise without using a tripod.</p> 
 (High Sensitivity)	<p>Allows you to shoot images without a flash under low light conditions, reducing blur.</p> 
 (Gourmet)	<p>Shifts to Macro mode, allowing you to shoot food arrangements in delicious and bright color.</p> 
 (Pet)	<p>Allows you to shoot images of your pet with the best settings.</p>

	
 (Beach)	<p>Allows you to record the blue of the water clearly when shooting seaside or lakeside scenes.</p> 
 (Snow)	<p>Allows you to record clear images preventing sunken colors in snowy scenes or other places where the whole screen appears white.</p> 
 (Fireworks)	<p>Allows you to record fireworks in all their splendor.</p> 

Notes

- When you shoot images using  (Twilight Portrait),  (Twilight) or  (Fireworks) mode, the shutter speed is slower and the images tend to blur. To prevent blurring, the use of a tripod is recommended.
- Some Scene Selection modes are available also in movie mode, but the selectable modes are limited. [\[Details\]](#)
- You may not be able to set some functions or MENU items depending on the selected REC mode. For details, see “Functions not available in some REC modes” [\[Details\]](#) and “MENU items not available in some REC modes.” [\[Details\]](#)

[▲ Back to top](#)



▶ Operation Search
▶ Before Use
▶ Shooting
▶ Viewing
▶ Using 3D Functions
▶ Using MENU items (Shooting)
▶ Using MENU items (Viewing)
▶ Changing settings
▶ Viewing images on a TV
▶ Using with your computer
▶ Printing
▶ Troubleshooting
▶ Precautions/About this camera

[→ Contents list](#)

Background Defocus

Allows you to shoot an image with image processing so that the background and the subject stands out.



1. Set the mode switch to  (Still Image).
2. Turn the control wheel to select  (Background Defocus).
3. Shoot with the shutter button.

Tips for adjusting the intensity of the background defocus

- Before shooting, select MENU → [Defocus Effect] → [High], [Mid] or [Low] to change the intensity of the background defocus effect.

Tips for defocusing the background

Position of the subject and the background

If you shoot an image with the subject and background far apart, as shown in the illustration, the background can be defocused. Shoot from the recommended shooting distance indicated on the LCD screen.

Subject is sufficiently removed from the background

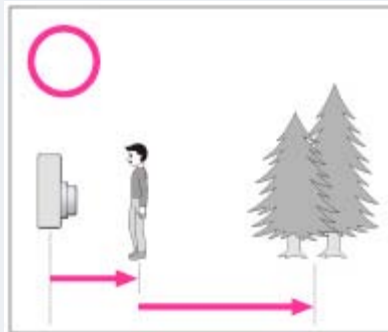

Subject and background are too close

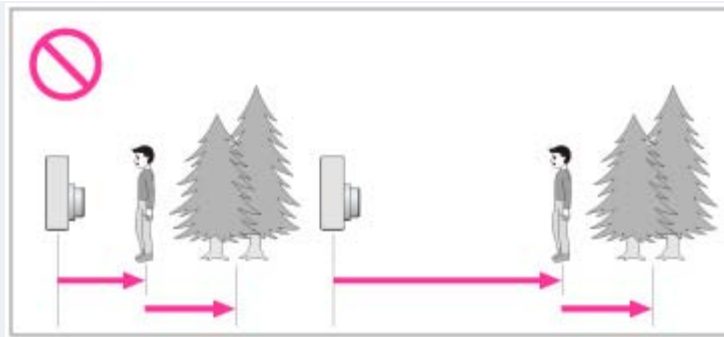

Zoom scale and position of the subject

When you shoot a flower and a small item from close up, turn the W/T (zoom) lever to the W side. For shooting people, move a short distance away from the subject and turn the W/T (zoom) lever to the T side.



- To lock the focus on the subject more easily, use the Tracking focus function of the camera. [\[Details\]](#)

Notes

- When shooting, hold the camera still to reduce camera shake.
- The background may not be defocused in the following situations:
 - The scene is too bright or too dark.
 - The subject is moving.
 - The subject is too far from the camera. (The recommended shooting distance has been exceeded.)
 - The subject is too close to the background.
- The Background Defocus effect may not work effectively in the following situations:
 - The subjects are too small.
 - The subject is the same color as the background.
 - You moved the camera after setting the AE/AF lock.
- If you are unable to defocus effectively, try the following steps:
 - Turn the W/T (zoom) lever to the T side.
 - Approach the subject until you are within the recommended shooting distance.
 - Separate the subject and the background.
 - Shoot after focusing on the subject.
- You may not be able to set some functions or MENU items depending on the selected REC mode. For details, see “Functions not available in some REC modes” [\[Details\]](#) and “MENU items not available in some REC modes.” [\[Details\]](#)

Related Topic

[Defocus Effect](#)

[Tracking focus](#)

Top page > Shooting > Setting still image shooting mode > Functions not available in some REC modes

Functions not available in some REC modes

In the table below, ✓ indicates a user-changeable function, while — indicates an unchangeable one. The icons below [Self-Timer] and [Flash] indicate the available modes.

		Self-Timer	Flash	Face Detection	Tracking focus	Burst Settings
REC Mode	(Intelligent Auto)	✓	AUTO	✓	✓	✓
	(Superior Auto)	✓	AUTO	✓	✓	—
	P (Program Auto)	✓	✓	✓	✓	✓
	(3D Still Image)	✓		✓	✓	—
	(Background Defocus)	✓		✓	✓	—
Scene Selection	(Soft Skin)	✓	✓	✓*1	✓	✓
	(Soft Snap)	✓	✓	✓*1	✓	✓
	(Anti Motion Blur)	✓		✓	✓	—
	(Landscape)			—	—	✓
	(Backlight Correction HDR)	✓		✓	✓	—
	(Twilight Portrait)	✓	SL	✓	✓	—
	(Twilight)			—	—	—
	(Hand-held Twilight)	✓		✓	✓	—
	(High Sensitivity)	✓		✓	✓	—
	(Gourmet)			—	✓	—
	(Pet)			—	✓	—
	(Beach)	✓		✓	✓	✓
	(Snow)	✓		✓	✓	✓
	(Fireworks)			—	—	—

*1 [Off] cannot be selected for [Face Detection].

- ▶ Operation Search
- ▶ Before Use
- ▶ Shooting
- ▶ Viewing
- ▶ Using 3D Functions
- ▶ Using MENU items (Shooting)
- ▶ Using MENU items (Viewing)
- ▶ Changing settings
- ▶ Viewing images on a TV
- ▶ Using with your computer
- ▶ Printing
- ▶ Troubleshooting
- ▶ Precautions/About this camera

[→ Contents list](#)

[▲ Back to top](#)

▶ Operation Search
▶ Before Use
▶ Shooting
▶ Viewing
▶ Using 3D Functions
▶ Using MENU items (Shooting)
▶ Using MENU items (Viewing)
▶ Changing settings
▶ Viewing images on a TV
▶ Using with your computer
▶ Printing
▶ Troubleshooting
▶ Precautions/About this camera

[→ Contents list](#)

Tracking focus

The camera tracks the subject and adjusts focus automatically until you press the shutter button halfway down, even if the subject is moving.

1. Press ● on the control wheel.
The target frame appears.



2. Place the target frame over the subject you want to focus on, and press ● .
Tracking begins.
3. Press the shutter button half way down.
The position of the subject, focus and exposure are locked.
4. Press the shutter button fully down to shoot the image.
5. To cancel the tracking focus before shooting, press ● again.

Tracking a face

If you use the tracking focus function while the Face Detection function is activated, you can select a face to be given priority and register that face with the camera. Even if the registered face disappears from the LCD screen, when it shows up on the LCD screen again, the camera focuses on the registered face.

- When a specified face is registered in the camera memory and you use the Smile Shutter function, the camera searches only for that face's smile.

Notes

- Tracking focus may fail to lock the focus, lose the subject or track different subject in the following situations:
 - The subject moves too quickly.
 - The subject is too small or too large.
 - The subject is the same color as the background.
 - Under low light conditions.
 - Under conditions where the brightness varies.
- When you use the Digital Zoom, the tracking focus function is not available.
- Tracking focus will automatically be canceled when the subject disappears from the screen or has failed to be tracked. However, if the target of the tracking focus is a specified face, the camera keeps tracking on that face even if the face disappears from the screen.
- You may not be able to set some functions depending on the selected REC mode. For details, see “Functions not available in some REC modes.” [\[Details\]](#)







- ▶ Operation Search
- ▶ Before Use
- ▶ Shooting
- ▶ Viewing
- ▶ Using 3D Functions
- ▶ Using MENU items (Shooting)
- ▶ Using MENU items (Viewing)
- ▶ Changing settings
- ▶ Viewing images on a TV
- ▶ Using with your computer
- ▶ Printing
- ▶ Troubleshooting
- ▶ Precautions/About this camera

[→ Contents list](#)

DISP (Display Setting)

▼ Histogram

1. Press **DISP** (Display Setting) on the control wheel.
2. Select the desired mode with the control wheel.

 (OFF)	Displays only images. 
 (Detailed Info)	Displays the information. Exif data for the recorded image and the histogram are also displayed. 
  (ON)	Displays the information. 

■ Histogram

A histogram is a graph showing the brightness of an image. The graph display indicates a bright image when skewed to the right side (**A**), and a dark image when skewed to the left side (**B**).



1. Press **DISP** (Display Setting) on the control wheel, then select [Detailed Info].

Notes

- The histogram also appears when playing back a single image, but you cannot adjust the exposure.
- The histogram does not appear when:
 - Recording/playing back movies
 - Viewing vertical orientation images
 - Rotating still images
 - Shooting/viewing in Intelligent Sweep Panorama mode
 - When [Display Burst Group] is set to [Display Main Image Only]
- A large difference in the histogram displayed during shooting and playback may occur when:
 - The flash strobos.
 - The shutter speed is slow or fast.
- The histogram may not appear for images recorded using other cameras.

[▲ Back to top](#)





Copyright 2011 Sony Corporation

▶ Operation Search
▶ Before Use
▶ Shooting
▶ Viewing
▶ Using 3D Functions
▶ Using MENU items (Shooting)
▶ Using MENU items (Viewing)
▶ Changing settings
▶ Viewing images on a TV
▶ Using with your computer
▶ Printing
▶ Troubleshooting
▶ Precautions/About this camera

[→ Contents list](#)

Flash

1. Press  (Flash) on the control wheel.
2. Select the desired mode with the control wheel.



	 AUTO (Auto)	Flash automatically operates in dark locations or when there is backlight.
	 (On)	Flash always operates.
	 SL (Slow Synchro)	Flash always operates. The shutter speed is slow in a dark place to clearly shoot the background that is out of flash light.
	 (Off)	Flash does not operate.

When the “White circular spots” appears in flash photos

This is caused by particles (dust, pollen, etc.) floating close to the lens. When they are accentuated by the camera’s flash, they appear as white circular spots.



How can the “White circular spots” be reduced?

- Light the room and shoot the subject without a flash.
- Select  (Anti Motion Blur) or  (High Sensitivity) mode in Scene Selection. ([Off] is automatically selected.)

Notes

- The flash strobos twice. The first flash adjusts the light quantity.
- While charging the flash,  is displayed.
- You cannot use the flash during burst shooting.
- When shooting with the flash and the zoom is set to W, the shadow of the lens may appear on the screen, depending on the shooting conditions. If this happens, set the zoom to T and shoot with the flash again.
- You may not be able to set some functions or MENU items depending on the selected REC mode. For details, see “Functions not available in some REC modes” [\[Details\]](#) and “MENU items not available in some REC modes.” [\[Details\]](#)

[▲ Back to top](#)



▶ Operation Search
▶ Before Use
▶ Shooting
▶ Viewing
▶ Using 3D Functions
▶ Using MENU items (Shooting)
▶ Using MENU items (Viewing)
▶ Changing settings
▶ Viewing images on a TV
▶ Using with your computer
▶ Printing
▶ Troubleshooting
▶ Precautions/About this camera

[→ Contents list](#)

Burst Settings

You can select Single (single-image) or Burst as the shooting mode.

1. Press  (Burst Settings) on the control wheel.
2. Select the desired mode with the control wheel.

<input checked="" type="checkbox"/>	 (Single)	The camera shoots a single image.
<input type="checkbox"/>	 (Burst)	The camera shoots up to 10 continuous frames in one burst when you hold down the shutter button. 

Notes

- [Flash] is set to [Off].
- When recording with the self-timer, a series of up to 10 images is recorded.
- [Focus], [White Balance], and [EV] are adjusted for the first image, and these settings are also used for the other images.
- When the battery level is low, or when the internal memory or a memory card is full, the burst stops.
- [VGA] image size will be set while recording on internal memory.
- You may not be able to set some functions or MENU items depending on the selected REC mode. For details, see "Functions not available in some REC modes" [\[Details\]](#) and "MENU items not available in some REC modes." [\[Details\]](#)

Related Topic

[Burst Shooting Interval](#)

[▲ Back to top](#)







- ▶ Operation Search
- ▶ Before Use
- ▶ Shooting
- ▶ Viewing
- ▶ Using 3D Functions
- ▶ Using MENU items (Shooting)
- ▶ Using MENU items (Viewing)
- ▶ Changing settings
- ▶ Viewing images on a TV
- ▶ Using with your computer
- ▶ Printing
- ▶ Troubleshooting
- ▶ Precautions/About this camera

➔ [Contents list](#)

Self-Timer

▼ Automatic shooting with Self-portrait timer

1. Press  (Self-Timer) on the control wheel.
2. Select the desired mode with the control wheel.

✔	 OFF (Off)	Does not use the self-timer.
	 (10sec)	Sets the self-timer to a 10-second delay. When you press the shutter button, the self-timer lamp flashes and a beep sounds until the shutter operates. To cancel, press  again.
	 (2sec)	Sets the self-timer to a 2-second delay.
	 (Self-portrait One Person)	Sets the self-timer to Self-portrait timer. When the camera detects the specified number of faces, a beep sounds, and the shutter operates 2 seconds later.
	 (Self-portrait Two People)	

Tips for preventing blur

If your hands or body moves while holding the camera and pressing the shutter button, “Camera shake” occurs.



Camera shake occurs frequently under low-light or slow shutter speed conditions, such as those encountered in  (Twilight Portrait) or  (Twilight) mode.

In such a case, shoot with the below tips in mind.

- Shoot with a 2-second delay self-timer and stabilize the camera by holding your arms firmly at your side after pressing the shutter button.
- Use a tripod or place the camera on a flat surface to hold the camera steady.

Note

- You may not be able to set some functions depending on the selected REC mode. For details, see “Functions not available in some REC modes.” [\[Details\]](#)

Automatic shooting with Self-portrait timer

Point the lens at yourself so your face is reflected in the LCD screen. The camera detects the subjects, and then the shutter operates. The camera determines the optimal composition and prevents faces from being cut out of the LCD screen. Do not move your camera after the beep sounds.



- You can also shoot an image by pressing the shutter button during this operation.

[▲ Back to top](#)

Copyright 2011 Sony Corporation

▶ Operation Search
▶ Before Use
▶ Shooting
▶ Viewing
▶ Using 3D Functions
▶ Using MENU items (Shooting)
▶ Using MENU items (Viewing)
▶ Changing settings
▶ Viewing images on a TV
▶ Using with your computer
▶ Printing
▶ Troubleshooting
▶ Precautions/About this camera

[➡ Contents list](#)

Viewing still images

1. Press the  (Playback) button to switch to playback mode.
2. Select an image with the control wheel.

Viewing images taken with a different camera

This camera creates an Image Database File on the memory card for recording and playing images. If the camera detects images not registered in the Image Database File on the memory card, a registration screen with the message “Files found which were not recognized Import files” will be displayed. To view unregistered images, register them by selecting [OK].

- Use a sufficiently charged battery to register images. If a battery with a low charge is used to register images, it may not be possible to register all of the data or the data may be corrupted if the battery charge runs out.







[▲ Back to top](#)

▶ Operation Search
▶ Before Use
▶ Shooting
▶ Viewing
▶ Using 3D Functions
▶ Using MENU items (Shooting)
▶ Using MENU items (Viewing)
▶ Changing settings
▶ Viewing images on a TV
▶ Using with your computer
▶ Printing
▶ Troubleshooting
▶ Precautions/About this camera



[→ Contents list](#)

Playback zoom

Enlarges the image being played back.

1. Press  (Playback) button to switch to playback mode.
2. Turn the W/T (zoom) lever to T side () during still image playback.
3. Adjust the position using  /  /  /  on the control wheel.
The frame in the lower left of the image shows which part of the total image is being displayed.



4. Change the zoom scale with the W/T (zoom) lever.
Turn the W/T (zoom) lever to T side () to zoom in, W side () to zoom out.
Press  on the control wheel to cancel playback zoom.

To save enlarged images

You can save an enlarged image by using the trimming function.
Press MENU → [Retouch] → [Trimming (Resize)].

[▲ Back to top](#)

- ▶ Operation Search
- ▶ Before Use
- ▶ Shooting
- ▶ Viewing
- ▶ Using 3D Functions
- ▶ Using MENU items (Shooting)
- ▶ Using MENU items (Viewing)
- ▶ Changing settings
- ▶ Viewing images on a TV
- ▶ Using with your computer
- ▶ Printing
- ▶ Troubleshooting
- ▶ Precautions/About this camera



→ Contents list

Image Index



▼ Displaying images of the desired date/folder

▼ Viewing images with the Calendar

Displays multiple images at the same time.

1. Press the  (Playback) button to switch to playback mode.
2. Turn the W/T (zoom) lever to the W side () to display the image index screen. Turn the lever again to display an index screen with more images.
3. To return to the single-image screen, select an image with the control wheel, then press .

■ Displaying images of the desired date/folder

Select the left side bar with the control wheel, then select the desired date range or folder using  / .





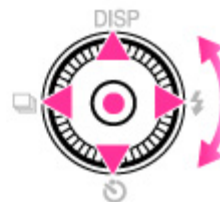

■ Viewing images with the Calendar



When [View Mode] is set to [Date View] and the screen display is in index mode, turn the W/T (zoom) lever to W side () to view images with the Calendar.



 /  /  /  : Moves the selection frame to a different date.

 : Displays the calendar of the next/previous month.

- To select the month you want to display, select  /  with the control wheel, then the desired month.
- To view images in selected date in index mode, select the date with the control wheel and press .

- To cancel the calendar display and return to an index screen, select  using the control wheel, then press .

[▲ Back to top](#)

Copyright 2011 Sony Corporation



- ▶ Operation Search
- ▶ Before Use
- ▶ Shooting
- ▶ Viewing
- ▶ Using 3D Functions
- ▶ Using MENU items (Shooting)
- ▶ Using MENU items (Viewing)
- ▶ Changing settings
- ▶ Viewing images on a TV
- ▶ Using with your computer
- ▶ Printing
- ▶ Troubleshooting
- ▶ Precautions/About this camera

[→ Contents list](#)

Delete button



Allows you to select unwanted images for deletion.

You can also delete images from the MENU button. [\[Details\]](#)

1. Press the  (Playback) button to switch to playback mode.
2.  (Delete) button → desired mode → ● on the control wheel

All Images on This Date All in This Folder All AVCHD files	Deletes all images in the selected date range or folder, or all AVCHD movies at once. Press [OK] → ● after step 2.
Multiple Images	Allows you to select and delete multiple images. Do as the following after step 2. ① Select an image then press ● . A ✓ mark is attached to the selected image. Repeat the above steps until there are no more images to be deleted. Select an image with a ✓ mark again to release the ✓ mark. ② MENU → [OK] → ●
This Image	Deletes the currently displayed image.
All Imgs in This Burst Group	Deletes all images in the selected burst group at once. Press [OK] → ● after step 2.
All but This Image	Deletes all images in a burst group except the selected image in Display Burst Group mode. Press [OK] → ● after step 2.
Cancel	Cancels the deletion.

You can switch between index and single-image mode when selecting images

Turn the W/T (zoom) lever to the T side () in index mode to return to single-image mode, and turn the lever to the W side () in single-image mode to return to index mode.

- You can also switch between index and single-image mode in [Protect], [Send by TransferJet] or [Print (DPOF)].



Note

- When the internal memory is used to record images, [View Mode] is set to [Folder View].

Related Topic

[Delete](#)

[▲ Back to top](#)

Copyright 2011 Sony Corporation

- ▶ Operation Search
- ▶ Before Use
- ▶ Shooting
- ▶ Viewing
- ▶ Using 3D Functions
- ▶ Using MENU items (Shooting)
- ▶ Using MENU items (Viewing)
- ▶ Changing settings
- ▶ Viewing images on a TV
- ▶ Using with your computer
- ▶ Printing
- ▶ Troubleshooting
- ▶ Precautions/About this camera

[→ Contents list](#)

Viewing burst images

▼ Tilt playback

▼ Unfold

You can select the playback method for continuous (burst) shots when [View Mode] is set to [Date View] and [Display Burst Group] is set to [Display Main Image Only]. [View Mode] is set to [Date View] and [Display Burst Group] is set to [Display Main Image Only] in its default setting.

1. Press the  (Playback) button to switch to playback mode.
2. Select the burst images using the control wheel then operate as following.

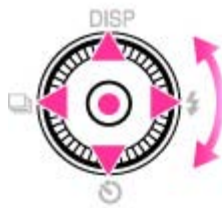

Control wheel	Action
●	Tilt playback You can view the burst images as a movie by tilting the camera to the right or left.
▶ ↘	Next image
◀ ↙	Previous image
▼	Unfold You can view the burst images in index.

● Tilt playback

The burst shots are played back smoothly as a movie.

1. Press ● on the control wheel to enter the Tilt playback screen.
2. Tilt the camera to the right or left, with the center of the camera as the axis.

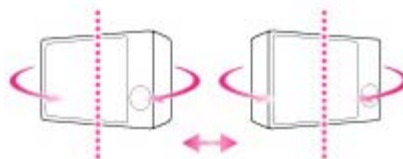

3. To exit Tilt playback, execute any operation, such as pressing ● on the control wheel.

▼ Unfold

The thumbnails of a series of burst shots are displayed on the bottom of the LCD screen. A selected image is enlarged.

1. Press ▼ on the control wheel to unfold the burst shots.
A series of burst shots are displayed in an index.



When images are displayed in an index,  is displayed on the main image.

2. Press ◀ / ▶ to display each image in a burst group.
3. Switch the display between single-image display and index display by pressing ● .
4. To cancel the display, press ▼ .

Related Topic

[View Mode](#)

[Display Burst Group](#)



[▲ Back to top](#)

- ▶ Operation Search
- ▶ Before Use
- ▶ Shooting
- ▶ Viewing
- ▶ Using 3D Functions
- ▶ Using MENU items (Shooting)
- ▶ Using MENU items (Viewing)
- ▶ Changing settings
- ▶ Viewing images on a TV
- ▶ Using with your computer
- ▶ Printing
- ▶ Troubleshooting
- ▶ Precautions/About this camera



→ Contents list

Viewing movies







▼ Displaying the control panel

1. Press the  (Playback) button to switch to playback mode.
2. Select a movie with the control wheel.
3. Press  .
Movie playback starts.





On the movie viewing screen

Select the image you want to display using  /  on the control wheel, and press  .
The Playback bar appears, you can check a playback position of a movie.

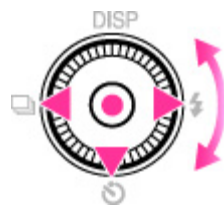

 AVCHD,  AVCHD,  AVCHD,  MP4,  MP4 or  MP4 appears on the movie viewing screen.
The icon displayed may vary depending on image size and quality.



Control wheel	Action during playback
	Stop
	Fast forward
	Fast rewind
	Frame advance
	Displays the control panel

To display only movies on the index screen

You can view only movie thumbnails on the index screen by pressing MENU →  (View



Mode) → (Folder view (MP4)) or (AVCHD view).

MP4 (Folder view (MP4)): Displays MP4-format movie thumbnails on the index screen.

AVCHD (AVCHD view): Displays AVCHD-format movie thumbnails on the index screen.

- When a movie file is played back to the end, the camera automatically starts playing back the next movie file.

Note

- You may not be able to play back some images shot using other cameras.

Displaying the control panel

Display the control panel, you can control slow movie playback and adjust the volume.

1. Press ▼ on the control wheel.
The control panel appears.
2. Select a desired button with ◀ / ▶, and press ●.



Control panel	Action
▶	Playback
⏸	Pause
⏩	Fast forward
⏪	Fast rewind
⏮	Slow playback
⏭	Slow rewind playback
⏴	Chapter advance
⏴	Chapter rewind
⏴	Frame advance
⏴	Frame rewind
🔊	Volume settings
✕	Closes the control panel

Note

- The buttons on the control panel will vary depending on the playback status.

Related Topic

[View Mode](#)

Scrolling the panorama images for display

You can scroll panorama images by pressing ● on the control wheel while panorama images are being displayed. Turn the W/T (zoom) lever to the W side to display the whole image again.



A: Shows the displayed area of the whole panorama image

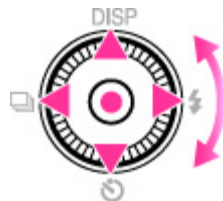

Control wheel	Action
●	Starts scrolling playback/pauses scrolling playback
⌋	Scrolls images

- Panorama images can also be played back using the supplied software “PMB”. [\[Details\]](#)
- Panorama images recorded using another camera may not scroll correctly when played.
- Turn the W/T (zoom) lever to the W side to display the whole image again.

Note

- A panoramic image recorded in [High Resolution] size requires a longer time to scroll than a normal size panoramic image.

Related Topic

[Still Image Size/Panorama Image Size](#)

- ▶ Operation Search
- ▶ Before Use
- ▶ Shooting
- ▶ Viewing
- ▶ Using 3D Functions
- ▶ Using MENU items (Shooting)
- ▶ Using MENU items (Viewing)
- ▶ Changing settings
- ▶ Viewing images on a TV
- ▶ Using with your computer
- ▶ Printing
- ▶ Troubleshooting
- ▶ Precautions/About this camera

[→ Contents list](#)

- ▶ Operation Search
- ▶ Before Use
- ▶ Shooting
- ▶ Viewing
- ▶ Using 3D Functions
- ▶ Using MENU items (Shooting)
- ▶ Using MENU items (Viewing)
- ▶ Changing settings
- ▶ Viewing images on a TV
- ▶ Using with your computer
- ▶ Printing
- ▶ Troubleshooting
- ▶ Precautions/About this camera

[➔ Contents list](#)

3D Functions

The camera is compatible with 3D functions. The following three modes are installed on this camera:

Images recorded using the 3D functions can be played back stereoscopically on a 3D TV. The basic differences among the three 3D modes are described here. For details on each mode, click [Details] below.

- 3D Still Image [\[Details\]](#)
- 3D Sweep Panorama [\[Details\]](#)
- Sweep Multi Angle [\[Details\]](#)



* The image on the TV screen is only for reference.

	Aspect ratio	Shooting mode	Playback method on this camera	Playback method on a 3D TV
3D Still Image	4:3 or 16:9 (Same aspect ratio as a standard still image.)	Still image	Same as a standard still image.	Stereoscopically
3D Sweep Panorama	Panorama	Panorama	Same as a standard still image.	Stereoscopically
Sweep Multi Angle	Panorama	Panorama	Tilt the camera to the right or left to view a stereoscopic image.	Stereoscopically

[▲ Back to top](#)





























- ▶ Operation Search
- ▶ Before Use
- ▶ Shooting
- ▶ Viewing
- ▶ Using 3D Functions
- ▶ Using MENU items (Shooting)
- ▶ Using MENU items (Viewing)
- ▶ Changing settings
- ▶ Viewing images on a TV
- ▶ Using with your computer
- ▶ Printing
- ▶ Troubleshooting
- ▶ Precautions/About this camera

[→ Contents list](#)

File name of the 3D image

A 3D image consists of both JPEG and MPO files.

If you import images shot using 3D functions into a computer, the image data is stored on the computer as follows.

	File name on the computer	Usage
3D Still Image	DSC0   .JPG DSC0   .MPO	For playing back the 3D images on a 3D TV
3D Sweep Panorama	DSC0     .JPG DSC0     .MPO	For playing back the 3D images on a 3D TV
Sweep Multi Angle	DSC0     .JPG DSC0     .MPO	For playing back the 3D images on a 3D TV
	DSC0     .JPG DSC0     .MPO	Shoots an image that can be played back as a stereoscopic image by tilting the camera to the right or left, and an image that can be played back on a 3D TV.

- If you shoot 3D images in [Sweep Multi Angle] mode, JPEG files and MPO files are stored on the computer for playing back on the camera and a 3D TV, respectively.
- If you delete either the JPEG file or the MPO file comprising a 3D image, that 3D image may not be played back successfully.



[▲ Back to top](#)

▶ Operation Search
▶ Before Use
▶ Shooting
▶ Viewing
▶ Using 3D Functions
▶ Using MENU items (Shooting)
▶ Using MENU items (Viewing)
▶ Changing settings
▶ Viewing images on a TV
▶ Using with your computer
▶ Printing
▶ Troubleshooting
▶ Precautions/About this camera

[→ Contents list](#)

3D Still Image

The camera shoots an image that can be played back as 3D on a 3D TV.

1. Set the mode switch to  (Still Image).
2. Turn the control wheel to select  (3D Still Image). [\[Details\]](#)
3. Shoot with the shutter button.

Tips for shooting 3D images

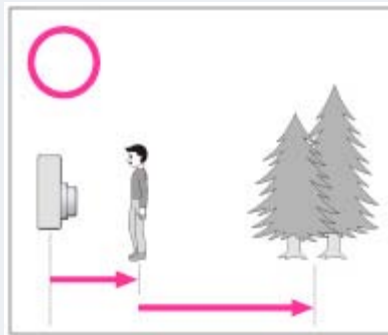

Shoot from a location near the subject, with the subject and background far apart, as shown in the illustration.

The 3D effect may not work effectively when the scene is too dark, the subject is moving or you moved the camera after setting the AE/AF lock.

If you shoot the image in a dark place, noise may be highly visible.

Note

- The available image size is [16M] or [16:9(12M)].

Related Topic

[Viewing 3D images on a 3D TV](#)



[▲ Back to top](#)

▶ Operation Search
▶ Before Use
▶ Shooting
▶ Viewing
▶ Using 3D Functions
▶ Using MENU items (Shooting)
▶ Using MENU items (Viewing)
▶ Changing settings
▶ Viewing images on a TV
▶ Using with your computer
▶ Printing
▶ Troubleshooting
▶ Precautions/About this camera

→ Contents list

3D Sweep Panorama

Multiple images are shot while the camera is moving, and these images are compiled into a 3D image. The recorded image can be played back on a 3D TV.

1. Set the mode switch to  (Sweep Panorama).
2. Turn the control wheel to select  (3D Sweep Panorama). [\[Details\]](#)
3. Select a shooting direction with the control wheel.
4. Align the camera with the end of the subject to be shot and press the shutter button.

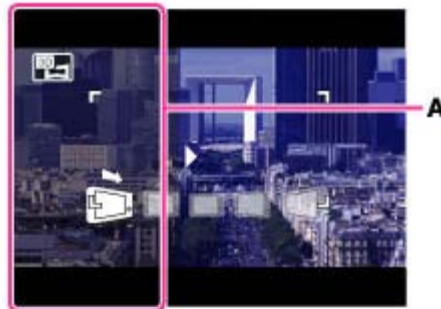

- A black, translucent portion (**A**) may not be recorded.

5. Pan the camera to the end of the guide (**B**), following the indication on the LCD screen.



Tips for shooting in 3D Sweep Panorama mode

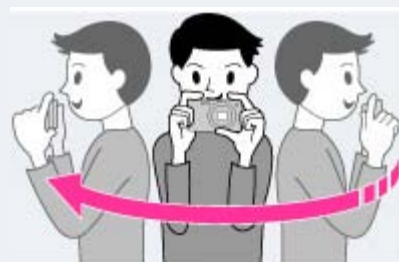

To take 3D images correctly, sweep the camera slowly. (Aim for a 5-second semicircle.) If you are sweeping too quickly or too slowly, a message will be displayed on the LCD screen. We recommend that you practice it several times before shooting. Subjects at rest are best suited for 3D shots.

- Determine the scene and press the shutter button halfway, so that you can lock the focus,

exposure and white balance. Then, press the shutter button fully down and pan the camera.

Notes

- 3D shooting is not suitable for the following situations:
 - When there is a large subject
 - Moving subjects
 - When the main subject is too close to the camera
 - Images with little contrast, such as the sky, a sandy beach, or lawn
- 3D images consist of a JPEG file and an MPO file. If either file is deleted on your PC, the camera may not operate correctly.
- If you cannot pan the camera across the entire subject within the given time, a gray area occurs in the composite image. If this happens, move the camera faster to record a full 3D image.
- Since several images are stitched together, the stitched part will not be recorded smoothly.
- Under low light conditions, the images may be blurred. It is recommended that you shoot images in bright outside light.
- Under lights that flicker, such as fluorescent lights, the 3D shot may not be successful.
- If the entire angle of view of the 3D shot and the angle of view when the AE/AF was locked are extremely different in brightness, color or focus, the shot will not be successful. If this happens, change the location of the AE/AF lock and try again.
- 3D shooting may be canceled in the following situations:
 - You pan the camera too quickly or too slowly.
 - There is too much camera shake.

Related Topic

[Viewing 3D images on a 3D TV](#)

[▲ Back to top](#)

Copyright 2011 Sony Corporation



- ▶ Operation Search
- ▶ Before Use
- ▶ Shooting
- ▶ Viewing
- ▶ Using 3D Functions
- ▶ Using MENU items (Shooting)
- ▶ Using MENU items (Viewing)
- ▶ Changing settings
- ▶ Viewing images on a TV
- ▶ Using with your computer
- ▶ Printing
- ▶ Troubleshooting
- ▶ Precautions/About this camera

[→ Contents list](#)

Sweep Multi Angle

As you sweep the camera, the camera shoots multiple images, then compiles them into one stereoscopic image.

It shoots an image that can be played back as a stereoscopic image by tilting the camera to the right or left, and an image that can be played back on a 3D TV.

1. Set the mode switch to  (Sweep Panorama).
2. Turn the control wheel to select  (Sweep Multi Angle). [\[Details\]](#)
3. Align the camera with the end of the subject to be shot and press the shutter button.



- A black, translucent portion (**A**) may not be recorded.

4. Pan the camera to the end of the guide (**B**), following the indication on the LCD screen.



Shootable range in Sweep Multi Angle mode

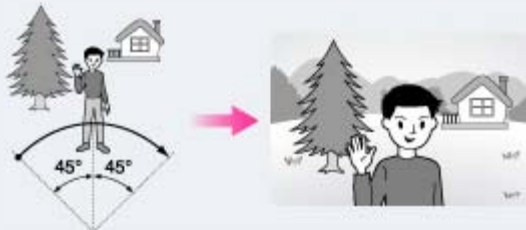

Sweep the camera approximately 45 degrees to the left and right of the subject you want to focus on.

Refer also to the tips for 3D Sweep Panorama. [\[Details\]](#)

Notes

- In [Sweep Multi Angle] mode, you can select only the [16:9(2M)] panorama image size.
- Refer also to “Notes” for the 3D Sweep Panorama. [\[Details\]](#)

Related Topic

[Viewing images shot in Sweep Multi Angle mode stereoscopically](#)





[▲ Back to top](#)

Copyright 2011 Sony Corporation

[Top page](#) > [Using 3D Functions](#) > [Viewing 3D images](#) > [Viewing images shot in Sweep Multi Angle mode stereoscopically](#)

Viewing images shot in Sweep Multi Angle mode stereoscopically

You can view the stereoscopic images shot in [Sweep Multi Angle] mode by tilting the camera to the right or left.

1. Press the  (Playback) button to switch to playback mode.
2. Select an image shot in  (Sweep Multi Angle) mode to be played back using the control wheel.
3. Press .
4. Tilt the camera to the right or left.
5. Press  again to end playback.

Tips for playing back stereoscopically

To view images shot in Sweep Multi Angle mode stereoscopically, tilt the camera to the right or left as illustrated, keeping the camera horizontal.

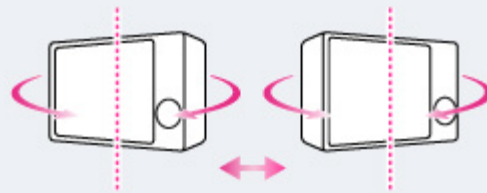

Note

- 3D images shot in [3D Still Image], [3D Sweep Panorama] mode cannot be played back in 3D on the camera.

- ▶ Operation Search
- ▶ Before Use
- ▶ Shooting
- ▶ Viewing
- ▶ Using 3D Functions
- ▶ Using MENU items (Shooting)
- ▶ Using MENU items (Viewing)
- ▶ Changing settings
- ▶ Viewing images on a TV
- ▶ Using with your computer
- ▶ Printing
- ▶ Troubleshooting
- ▶ Precautions/About this camera

[➔ Contents list](#)

[▲ Back to top](#)

- ▶ Operation Search
- ▶ Before Use
- ▶ Shooting
- ▶ Viewing
- ▶ Using 3D Functions
- ▶ Using MENU items (Shooting)
- ▶ Using MENU items (Viewing)
- ▶ Changing settings
- ▶ Viewing images on a TV
- ▶ Using with your computer
- ▶ Printing
- ▶ Troubleshooting
- ▶ Precautions/About this camera

[→ Contents list](#)

Viewing 3D images on a 3D TV

You can view 3D images recorded on the camera in 3D format by connecting the camera to a 3D TV using an HDMI Cable (sold separately).

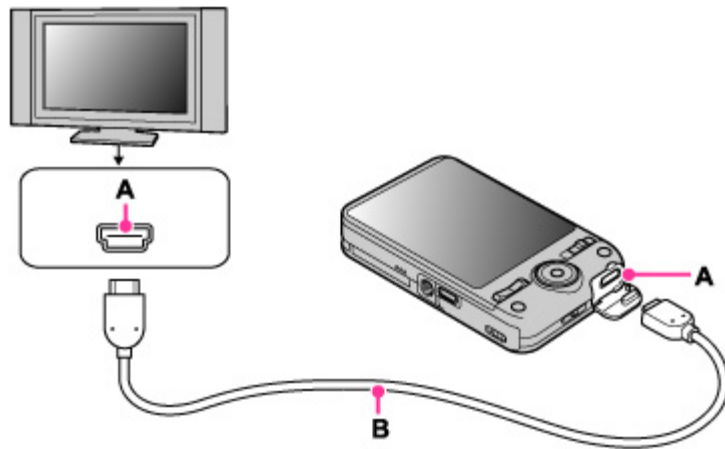

Refer also to the operating instructions supplied with the TV.

1. Turn off both the camera and the TV.
2. Connect the camera to the TV using an HDMI Cable (sold separately).





A: HDMI jack

B: HDMI Cable

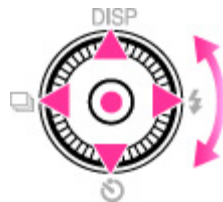
3. Turn on the TV and set the input.
4. Press the  (Playback) button to turn on the camera.
5. MENU →  (3D Viewing) → ● on the control wheel
Images shot with the camera appear on the TV.
6. Select images and set the desired mode using the control wheel.



Control wheel	Action
●	Plays back scrolling images shot in 3D Sweep Panorama mode. <ul style="list-style-type: none"> ● Press ◀ / ▶ to move the direction of scrolling. ● When playing back a 3D image shot in [16:9] image size, scrolling playback is not available.
▲	Continuously plays back only 3D images.

	Previous image
	Next image
	Ends 3D playback.

- You can change the zoom scale using the W/T (zoom) lever.

Notes

- When you select  (3D Viewing) mode, only 3D images are displayed.
- If you play back an image shot in [3D Sweep Panorama] mode with the shooting direction set to up or down, the image is played back horizontally on the TV.
- The beep sound is fixed to [Shutter].
- Do not connect the camera and equipment to be connected using output terminals. When the camera and TV are connected using output terminals, no video and sound are produced. Such a connection can also cause trouble of the camera and/or connected equipment.
- This function may not work properly with some TVs. For example, you may not be able to view a video on your TV, output in 3D mode or hear sound from the TV.
- Use an HDMI Cable with the HDMI logo.
- When connecting the camera to a TV, use an HDMI Cable that can be connected to the mini jack on the camera end and to the TV jack.
- Recording may automatically stop to protect the camera after a period of time when you shoot movies in the condition where the camera and TV are connected by an HDMI Cable (sold separately).

Related Topic

[3D Viewing](#)

[▲ Back to top](#)

Copyright 2011 Sony Corporation

- ▶ Operation Search
- ▶ Before Use
- ▶ Shooting
- ▶ Viewing
- ▶ Using 3D Functions
- ▶ Using MENU items (Shooting)
- ▶ Using MENU items (Viewing)
- ▶ Changing settings
- ▶ Viewing images on a TV
- ▶ Using with your computer
- ▶ Printing
- ▶ Troubleshooting
- ▶ Precautions/About this camera

[→ Contents list](#)

Using MENU items (Shooting)

You can select the various shooting functions easily from the MENU button.

1. Press the ON/OFF (Power) button and set the camera to shooting mode.
2. Press the MENU button to display the Menu screen.

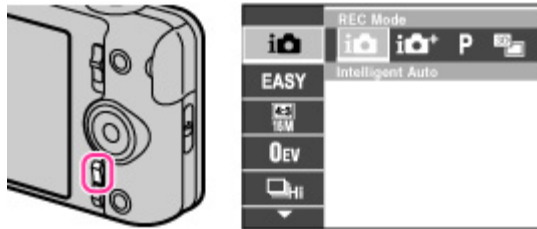

3. Select the desired menu item with ▲ / ▼ on the control wheel.



4. Select the desired item with ◀ / ▶ on the control wheel or by turning the control wheel.

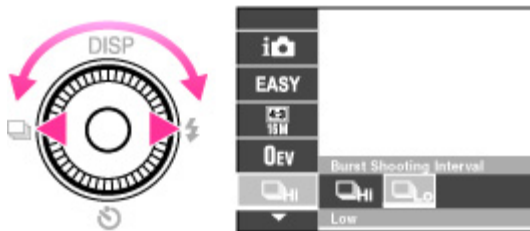

5. Press the MENU button to close the Menu screen.

[▲ Back to top](#)





▶ Operation Search
▶ Before Use
▶ Shooting
▶ Viewing
▶ Using 3D Functions
▶ Using MENU items (Shooting)
▶ Using MENU items (Viewing)
▶ Changing settings
▶ Viewing images on a TV
▶ Using with your computer
▶ Printing
▶ Troubleshooting
▶ Precautions/About this camera

[→ Contents list](#)

REC Mode

You can select the still image shooting mode when the mode switch is set to  (Still Image).

1. MENU →  (REC Mode) → desired mode

  (Intelligent Auto)	Allows you to shoot with the setting adjusted automatically. [Details]
 (Superior Auto)	Allows you to shoot still images in higher quality than with Intelligent Auto mode.
P (Program Auto)	Allows you to shoot with the exposure adjusted automatically (both the shutter speed and the aperture value). [Details] Also you can select various settings using the menu.
 (3D Still Image)	Allows you to shoot images that can be played back stereoscopically on a 3D TV. [Details]
SCN (Scene Selection)	Allows you to shoot with preset settings according to the scene. [Details]
 (Background Defocus)	Allows you to shoot an image with background defocus and define the subject.

Related Topic

[Using the control wheel](#)

[▲ Back to top](#)

- ▶ Operation Search
- ▶ Before Use
- ▶ Shooting
- ▶ Viewing
- ▶ Using 3D Functions
- ▶ Using MENU items (Shooting)
- ▶ Using MENU items (Viewing)
- ▶ Changing settings
- ▶ Viewing images on a TV
- ▶ Using with your computer
- ▶ Printing
- ▶ Troubleshooting
- ▶ Precautions/About this camera

[→ Contents list](#)

Movie shooting scene

You can select the movie shooting mode when the mode switch is set to  (Movie).

1. MENU →  (Movie shooting scene) → desired mode













✓	 (Intelligent Auto)	Allows you to shoot movies with the settings adjusted automatically. [Details]
	SCN (Scene Selection)	Allows you to shoot movies with preset settings according to the scene. [Details]

On Scene Recognition

Scene Recognition operates in Intelligent Auto mode. This function lets the camera automatically recognize the shooting conditions and shoot the image.



In Scene Recognition, the position of an icon displayed on the LCD screen is different depending on the circumstances. It depends on whether the camera recognizes a scene or condition.

If the camera recognizes a scene, icons and guides such as  (Portrait),  (Infant),  (Twilight Portrait),  (Twilight),  (Backlight Portrait),  (Backlight),  (Landscape),  (Macro),  (Spotlight) or  (Low Light) are displayed on the first line. If the camera recognizes a condition, icons such as  (Tripod) or  (Move) are displayed on the second line. The camera may recognize both the scene and condition, or just one.

For details, see “Scene Recognition.” [\[Details\]](#)

[▲ Back to top](#)





- ▶ Operation Search
- ▶ Before Use
- ▶ Shooting
- ▶ Viewing
- ▶ Using 3D Functions
- ▶ Using MENU items (Shooting)
- ▶ Using MENU items (Viewing)
- ▶ Changing settings
- ▶ Viewing images on a TV
- ▶ Using with your computer
- ▶ Printing
- ▶ Troubleshooting
- ▶ Precautions/About this camera

[➔ Contents list](#)

Panorama Shooting Scene

Select a panorama shooting mode when the mode switch is set to  (Sweep Panorama).

1. MENU →  (Panorama Shooting Scene) → desired mode

	 (iSweep Panorama)	Shoots a regular panorama image. [Details]
	 (3D Sweep Panorama)	Shoots a panorama image that can be played back stereoscopically on a 3D TV. [Details]
	 (Sweep Multi Angle)	Shoots a panorama image that can be played back stereoscopically on the camera. [Details]



[▲ Back to top](#)

- ▶ Operation Search
- ▶ Before Use
- ▶ Shooting
- ▶ Viewing
- ▶ Using 3D Functions
- ▶ Using MENU items (Shooting)
- ▶ Using MENU items (Viewing)
- ▶ Changing settings
- ▶ Viewing images on a TV
- ▶ Using with your computer
- ▶ Printing
- ▶ Troubleshooting
- ▶ Precautions/About this camera









[➔ Contents list](#)













Scene Selection









Allows you to shoot with preset settings according to the scene.

1. When the mode switch is set to  (Still Image):
 MENU →  (REC Mode) → **SCN** (Scene Selection) → desired mode → ● on the control wheel
- When the mode switch is set to  (Movie):
 MENU →  (Movie shooting scene) → **SCN** (Scene Selection) → desired mode → ● on the control wheel



Scene Selection modes with an * mark are not available for **SCN** (Scene Selection) in [Movie shooting scene].

 (Soft Skin)*	Allows you to shoot faces for smoothness. 
 (Soft Snap)	Allows you to shoot images with a softer atmosphere for portraits and flowers, etc. 
 (Anti Motion Blur)*	Allows you to shoot indoor shots without using the flash to reduce subject blur. 
 (Landscape)	Allows easy shooting of distant scenes by focusing in the distance. Shoots the clear sky and trees and flowers in vivid colors. 

 + (Backlight Correction HDR)*	<p>Allows you to shoot three images having different exposures to create a single image with a greater range of gradation. The camera combines the dark parts of an image taken with a bright exposure setting and the bright parts of an image taken with a dark exposure setting.</p> 
 (Twilight Portrait)*	<p>Allows you to shoot sharp images of people with the night view in the background without compromising the atmosphere.</p> 
 (Twilight)	<p>Allows you to shoot night scenes at far distance without losing the dark atmosphere of the surroundings.</p> 
 (Hand-held Twilight)*	<p>Allows you to shoot night scenes with less noise without using a tripod.</p> 
 (High Sensitivity)	<p>For still images, allows you to shoot images without a flash under low light conditions, reducing blur. For movies, allows you to record low light scenes with more brightness.</p> 
 (Gourmet)*	<p>Allows you to shoot food arrangements in delicious and bright colors using Macro mode.</p> 

 (Pet)*	<p>Allows you to shoot images of your pet with the best settings.</p> 
 (Beach)	<p>Allows you to shoot images with the proper settings for seaside or lakeside scenes.</p> 
 (Snow)	<p>Allows you to record clear images preventing sunken colors in snowy scenes or other places where the whole screen appears white.</p> 
 (Fireworks)	<p>Allows you to record fireworks in all their splendor.</p> 

Notes

- When you shoot images using  (Twilight Portrait),  (Twilight) or  (Fireworks) mode, the shutter speed is slower and the images tend to blur. To prevent blurring, the use of a tripod is recommended.
- You may not be able to set some functions or MENU items depending on the selected REC mode. For details, see “Functions not available in some REC modes” [\[Details\]](#) and “MENU items not available in some REC modes.” [\[Details\]](#)

[▲ Back to top](#)

- ▶ Operation Search
- ▶ Before Use
- ▶ Shooting
- ▶ Viewing
- ▶ Using 3D Functions
- ▶ Using MENU items (Shooting)
- ▶ Using MENU items (Viewing)
- ▶ Changing settings
- ▶ Viewing images on a TV
- ▶ Using with your computer
- ▶ Printing
- ▶ Troubleshooting
- ▶ Precautions/About this camera

→ [Contents list](#)

Easy Mode

▼ On Scene Recognition

▼ Shooting functions available in Easy Mode (Shooting)

Allows you to shoot still images using the minimum necessary functions. The text size increases and indicators become easier to see.

1. MENU → **EASY** (Easy Mode) → ● on the control wheel
2. [OK] → ●
3. Shoot with the shutter button.
 - To end Easy Mode, MENU → [Exit Easy Mode]

Note

- The battery power may decrease faster because the screen brightness increases automatically.

On Scene Recognition

Scene Recognition operates in Easy Mode. This function lets the camera automatically recognize the shooting conditions and shoot the image.



In Scene Recognition, the position of an icon displayed on the LCD screen is different depending on the circumstances. It depends on whether the camera recognizes a scene or condition.

If the camera recognizes a scene, icons such as (Portrait), (Infant), (Twilight Portrait), (Twilight), (Backlight Portrait), (Backlight), (Landscape), (Macro), (Spotlight) or (Low Light) are displayed on the first line. If the camera recognizes a condition, icons such as (Tripod) or (Move) are displayed on the second line. The camera may recognize both the scene and condition, or just one.

For details, see “Scene Recognition.” [\[Details\]](#)

Shooting functions available in Easy Mode (Shooting)

MOVIE (Movie) button	Allows you to record movies with their audio.
	MENU → [Still Image Size] → ● on the control wheel → desired

Still Image Size	mode → ● Select between [Large] or [Small] size.
Self-Timer	⌚ on the control wheel → desired mode Select between [On] or [Off] mode.
Flash	⚡ on the control wheel → desired mode Select between [Auto] or [Off] mode.

Related Topic

[Scene Recognition](#)

[▲ Back to top](#)

Copyright 2011 Sony Corporation



- ▶ Operation Search
- ▶ Before Use
- ▶ Shooting
- ▶ Viewing
- ▶ Using 3D Functions
- ▶ Using MENU items (Shooting)
- ▶ Using MENU items (Viewing)
- ▶ Changing settings
- ▶ Viewing images on a TV
- ▶ Using with your computer
- ▶ Printing
- ▶ Troubleshooting
- ▶ Precautions/About this camera

[➡ Contents list](#)

Defocus Effect

Sets the level of background defocus effect when shooting in Background Defocus mode.

1. MENU →  (Defocus Effect) → desired mode

	(Low)	Adds a slight Background Defocus effect.
<input checked="" type="checkbox"/>	 (Mid)	Adds an average Background Defocus effect.
	(High)	Adds a strong Background Defocus effect.

Related Topic

[Background Defocus](#)

[▲ Back to top](#)

- ▶ Operation Search
- ▶ Before Use
- ▶ Shooting
- ▶ Viewing
- ▶ Using 3D Functions
- ▶ Using MENU items (Shooting)
- ▶ Using MENU items (Viewing)
- ▶ Changing settings
- ▶ Viewing images on a TV
- ▶ Using with your computer
- ▶ Printing
- ▶ Troubleshooting
- ▶ Precautions/About this camera

[→ Contents list](#)

Still Image Size/Panorama Image Size

- ▼ Image size when shooting still images
- ▼ 3D Still Image Size
- ▼ Image size in Easy Mode
- ▼ Image size when shooting Sweep Panorama

The image size determines the size of the image file that is recorded when you take an image. The larger the image size, the more detail will be reproduced when the image is printed on large-format paper. The smaller the image size, the more images can be recorded.

💡 On “image quality” and “image size”

A digital image is made up of a collection of small dots called pixels. If it contains a large number of pixels (**A**), the image becomes large, it takes up more memory, and the image is displayed in fine detail. “Image size” is shown by the number of pixels. Although you cannot see the differences on the screen of the camera, the fine detail and data processing time differ when the image is printed or displayed on a computer screen.

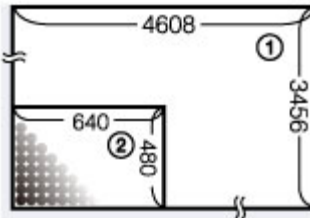

- ① Image size: 16M
4608 pixels × 3456 pixels = 15,925,248 pixels
- ② Image size: VGA
640 pixels × 480 pixels = 307,200 pixels

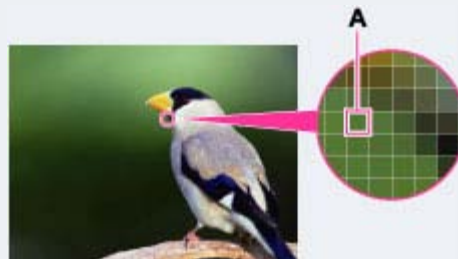











Many pixels (Fine image quality and large file size)



Few pixels (Rough image quality but small file size)



Image size when shooting still images

1. MENU →  (Still Image Size) → desired size

	Image size	Usage guidelines	No. of images	Printing
✓	 (4608×3456)	For prints up to A3+ size	Less	Fine
	 (3648×2736)	For prints up to A3 size	 	 
	 (2592×1944)	For prints from 10×15 cm up to A4 size		
	 (640×480)	For e-mail attachments		
	 (4608×2592)	For viewing on a high-definition TV and printing up to A3 size	Less	Fine
	 (1920×1080)	For viewing on a high-definition TV	More	Rough

3D Still Image Size

1. MENU →  (Still Image Size) → desired size

✓	 (4608×3456)	For prints up to A3+ size
	 (4608×2592)	For viewing on a high-definition TV and printing up to A3 size

Note

- When you print still images recorded at a 16:9 aspect ratio or panorama images, both edges may be cut off.





Image size in Easy Mode

1. MENU → [Still Image Size] → desired size

✓	Large	Shoots images in [16M] size.
	Small	Shoots images in [5M] size.

Image size when shooting Sweep Panorama

1. MENU →  (Panorama Image Size) → desired size

	 (16:9) (Horizontal: 1920 × 1080)	[16:9] is available only for 3D shooting.
✓	 (Standard) (Horizontal: 4912 × 1080) (Vertical: 3424 × 1920)	Shoots images using standard size.
	 (Wide) (Horizontal: 7152 × 1080) (Vertical: 4912 × 1920)	Shoots images using wide size.
	 (High Resolution) (Horizontal: 10480 × 4096)	Shoots high-resolution panorama in 43 megapixel size.



Note

- If you cannot print panoramic images recorded in [High Resolution] size due to the large size, use the resize function in the supplied software “PMB”. “PMB” allows you to resize panoramic images recorded in [High Resolution] to 50%, etc.

[▲ Back to top](#)

Movie Quality/Movie Size

The larger the size of the movie image, the higher the image quality. The higher the amount of data used per second (average bit-rate), the higher the image quality.



Select a movie recording format by pressing MENU →  (Settings) →  (Shooting Settings) → [Movie format] in shooting mode. [\[Details\]](#)

If [Movie format] is [AVCHD], select the movie size from [Movie Quality], and if [Movie format] is [MP4], select from [Movie Size].

Movie quality (recording format: AVCHD)

1. MENU → [Movie Quality] → desired mode



Movies shot with this camera are recorded in AVCHD format, at approximately 60 fields/sec (for 1080 60i-compatible devices) or 50 fields/sec (for 1080 50i-compatible devices), in interlaced mode, with Dolby Digital audio, AVCHD format.

	Movie quality	Average bit-rate	Description
	 AVC HD 24M (FX)	24 Mbps	Shoots at the highest picture quality of 1920×1080 (50i/60i) size
	 AVC HD 17M (FH)	17 Mbps	Shoots at a high picture quality of 1920×1080 (50i/60i) size
	 AVC HD 9M (HQ)	9 Mbps	Shoots at a standard picture quality of 1440×1080 (50i/60i) size

Movie image size (recording format: MP4)

1. MENU → [Movie Size] → desired size

Movies shot with this camera are recorded in MPEG-4 format, at approximately 30 frames/sec (for 1080 60i-compatible devices) or approximately 25 frames/sec (for 1080 50i-compatible devices), in progressive mode, with AAC audio, mp4 format.

	Movie image size	Average bit-rate	Description
	 MP4 12M	12 Mbps	Shoots at 1440×1080 size
	 MP4 6M	6 Mbps	Shoots at 1280×720 size
	 MP4 3M	3 Mbps	Shoots at VGA size

Notes

- A telephoto image is produced when [MP4 3M] image size is selected.
- AVCHD discs cannot be created from movies recorded in [AVC HD 24M (FX)] quality. Save [AVC HD 24M (FX)] quality movies to Blu-ray discs.

- ▶ Operation Search
- ▶ Before Use
- ▶ Shooting
- ▶ Viewing
- ▶ Using 3D Functions
- ▶ Using MENU items (Shooting)
- ▶ Using MENU items (Viewing)
- ▶ Changing settings
- ▶ Viewing images on a TV
- ▶ Using with your computer
- ▶ Printing
- ▶ Troubleshooting
- ▶ Precautions/About this camera

→ [Contents list](#)

▶ Operation Search
▶ Before Use
▶ Shooting
▶ Viewing
▶ Using 3D Functions
▶ Using MENU items (Shooting)
▶ Using MENU items (Viewing)
▶ Changing settings
▶ Viewing images on a TV
▶ Using with your computer
▶ Printing
▶ Troubleshooting
▶ Precautions/About this camera

[➔ Contents list](#)

EV

You can adjust the exposure manually in 1/3 EV steps in a range of -2.0 EV to +2.0 EV.

1. MENU → **0EV** (EV) → desired EV setting

💡 Adjusting the exposure for better looking images



A: Overexposure (too much light)

B: Correct exposure

C: Underexposure (too little light)

Notes

- If you shoot a subject in extremely bright or dark conditions, or when you use the flash, the exposure adjustment may not be effective.
- You may not be able to set some MENU items depending on the selected REC mode. For details, see “MENU items not available in some REC modes.” [\[Details\]](#)

[▲ Back to top](#)

- ▶ Operation Search
- ▶ Before Use
- ▶ Shooting
- ▶ Viewing
- ▶ Using 3D Functions
- ▶ Using MENU items (Shooting)
- ▶ Using MENU items (Viewing)
- ▶ Changing settings
- ▶ Viewing images on a TV
- ▶ Using with your computer
- ▶ Printing
- ▶ Troubleshooting
- ▶ Precautions/About this camera

[→ Contents list](#)

ISO

Adjusts the luminous sensitivity when the camera is set to Program Auto.

1. MENU → ^{ISO}AUTO (ISO) → desired mode

✔	ISO AUTO (Auto)	Sets the ISO sensitivity automatically.
	ISO ISO ISO 100/200/400/ ISO ISO ISO 800/1600/3200	You can reduce image blurring in dark locations or with moving subjects by increasing the ISO sensitivity (select a larger number).

Adjusting ISO Sensitivity (Recommended Exposure Index)

ISO sensitivity is a speed rating for recording media that incorporates an image sensor that receives light. Even when the exposure is the same, images differ depending on the ISO sensitivity.

High ISO sensitivity



Records a bright image even in dark locations while increasing shutter speed to reduce blur. However, the image tends to become noisy.

Low ISO sensitivity



Records a smoother image. However, when the exposure is insufficient, the image may become darker.

Hints for preventing blur

Even though the camera is steady, the subject moves during the exposure and is captured blurred when the shutter button is pressed. Camera shake is reduced automatically, however, the function does not effectively reduce subject blur.

Subject blur occurs frequently under low-light or slow shutter speed conditions.

In such case, shoot with the below tips in mind.



- Select a higher ISO sensitivity so that the shutter speed is faster.
- Select **ISO** (High Sensitivity) mode in Scene Selection.

Note

- You may not be able to set some MENU items depending on the selected REC mode. For details, see “MENU items not available in some REC modes.” [\[Details\]](#)

[▲ Back to top](#)

Copyright 2011 Sony Corporation

- ▶ Operation Search
- ▶ Before Use
- ▶ Shooting
- ▶ Viewing
- ▶ Using 3D Functions
- ▶ Using MENU items (Shooting)
- ▶ Using MENU items (Viewing)
- ▶ Changing settings
- ▶ Viewing images on a TV
- ▶ Using with your computer
- ▶ Printing
- ▶ Troubleshooting
- ▶ Precautions/About this camera











[→ Contents list](#)

White Balance

▼ To capture the basic white color in [One Push Set] mode

Adjusts color tones according to the surrounding light conditions. Use this function if image color appears unnatural.

1. MENU →  (White Balance) → desired mode

✓	 (Auto)	Adjusts the white balance automatically so that the colors appear natural.
	(Daylight)	Adjusts for outdoors conditions on a fine day, evening views, night scenes, neon signs, fireworks, etc.
	(Cloudy)	Adjusts for a cloudy sky or a shady location.
	(Fluorescent White Balance 1)	[Fluorescent White Balance 1]: Adjusts for white fluorescent lighting. [Fluorescent White Balance 2]: Adjusts for natural white fluorescent lighting. [Fluorescent White Balance 3]: Adjusts for day white fluorescent lighting.
	(Fluorescent White Balance 2)	
	(Fluorescent White Balance 3)	
	(Incandescent)	Adjusts for places under incandescent lamp, or under bright lighting, such as in a photo studio.
	(Flash)	Adjusts for the flash conditions.
	(One Push)	Adjusts the white balance depending on the light source. The white color memorized in [One Push Set] mode becomes the basic white color. Use this mode when [Auto] and other settings don't provide accurate colors.
	(One Push Set)	Memorizes the basic white color which will be used in [One Push] mode. [Details]

Effects of lighting conditions

The apparent color of the subject is affected by the lighting conditions. The color tones are adjusted automatically, but you can adjust color tones manually using the White Balance function.



Daylight (White as Standard)



Cloudy (Bluish)



Fluorescent (Green-tinged)



Incandescent (Reddish)

Notes

- Under fluorescent lights that flicker, the white balance function may not work correctly even though you select [Fluorescent White Balance 1], [Fluorescent White Balance 2] or [Fluorescent White Balance 3].
- When shooting with a flash in other than [Flash] mode, [White Balance] is set to [Auto].
- When [Flash] is [On] or [Slow Synchro], the white balance can only be adjusted to [Auto], [Flash], [One Push] or [One Push Set].
- [One Push Set] cannot be selected while charging the flash.
- You may not be able to set some MENU items depending on the selected REC mode. For details, see “MENU items not available in some REC modes.” [\[Details\]](#)

To capture the basic white color in [One Push Set] mode

1. Frame a white object such as a piece of paper filling the screen under the same lighting conditions as you will shoot the subject.
2. MENU →  AUTO (White Balance) → [One Push Set] → ● on the control wheel
The screen momentarily turns black, and when the white balance has been adjusted and stored in the memory, the recording screen is displayed again.

Notes

- If the  indicator flashes while shooting, the white balance is either not set or cannot be set. Use automatic white balance.
- Do not shake or strike the camera while [One Push Set] is in progress.
- When flash mode is set to [On] or [Slow Synchro], the white balance is adjusted to the condition with the flash emitting.

- ▶ Operation Search
- ▶ Before Use
- ▶ Shooting
- ▶ Viewing
- ▶ Using 3D Functions
- ▶ Using MENU items (Shooting)
- ▶ Using MENU items (Viewing)
- ▶ Changing settings
- ▶ Viewing images on a TV
- ▶ Using with your computer
- ▶ Printing
- ▶ Troubleshooting
- ▶ Precautions/About this camera

[→ Contents list](#)

Focus







▼ Focusing on subjects near the edge of the screen

You can change the focus method. Use the menu when it is difficult to get the proper focus in auto focus mode.

AF stands for "Auto Focus," a function that adjusts the focus automatically.

The selected AF range finder frame appears on the screen.

1. MENU →  (Focus) → desired mode

 ✓ (Multi AF)	<p>Focuses on a subject in all ranges of the finder frame automatically. When you press the shutter button halfway down in still image shooting mode, a green frame is displayed around the area that is in focus.</p>  <ul style="list-style-type: none"> ● When the Face Detection function is active, AF operates with priority on faces.
 (Center AF)	<p>Focuses on a subject in the center of the finder frame automatically. Using the AF lock function together, you can compose the image the way you want.</p> 
 (Spot AF)	<p>Focuses on an extremely small subject or a narrow area automatically. Using the AF lock function together, you can compose the image the way you want.</p>  <ul style="list-style-type: none"> ● Hold the camera steady so as not to misalign the subject and the AF range finder frame.

Notes

- When you use [Digital Zoom] or [AF Illuminator], the AF range finder frame is disabled and appears in a dotted line. In this case, the camera works to focus on the subjects at the center of the screen.
- When the focus mode is set to other than [Multi AF], you cannot use the Face Detection function.

- If Tracking focus is activated, the camera focuses with priority on the subject to be tracked.
- You may not be able to set some MENU items depending on the selected REC mode. For details, see “MENU items not available in some REC modes.” [\[Details\]](#)

Focusing on subjects near the edge of the screen

If the subject is out of focus, do as follows:



1. Recompose the shot so that the subject is centered in the AF range finder **(A)**, and press the shutter button halfway to focus on the subject (AF lock).
2. When the AE/AF lock indicator **(B)** stops flashing and remains on, return to the fully composed shot, and press the shutter button fully down.
 - As long as you do not press the shutter button fully down, you can retry the procedure as many times as necessary.

Related Topic

[Tracking focus](#)

[▲ Back to top](#)

Copyright 2011 Sony Corporation





- ▶ Operation Search
- ▶ Before Use
- ▶ Shooting
- ▶ Viewing
- ▶ Using 3D Functions
- ▶ Using MENU items (Shooting)
- ▶ Using MENU items (Viewing)
- ▶ Changing settings
- ▶ Viewing images on a TV
- ▶ Using with your computer
- ▶ Printing
- ▶ Troubleshooting
- ▶ Precautions/About this camera

[➔ Contents list](#)

Metering Mode

Selects the metering mode that sets which part of the subject to measure to determine the exposure.

1. MENU →  (Metering Mode) → desired mode

<input checked="" type="checkbox"/>	 (Multi)	Divides into multiple regions and measures each region. The camera determines a well-balanced exposure (Multi-pattern metering).
<input type="checkbox"/>	 (Center)	Measures the center of the image, and determines the exposure based on the brightness of the subject there (Center-weighted metering).
<input type="checkbox"/>	 (Spot)	Align the spot metering cross hairs (A) on the subject to meter one part of the subject (Spot metering). This function is useful when the subject is backlit or when there is strong contrast between the subject and the background. 

Notes



- In movie mode, [Spot] cannot be selected.
- If you set [Metering Mode] to other than [Multi], the Face Detection function cannot be used.
- You may not be able to set some MENU items depending on the selected REC mode. For details, see “MENU items not available in some REC modes.” [\[Details\]](#)

[▲ Back to top](#)

Burst Shooting Interval

Selects the number of images taken per second for Burst shooting.

1. MENU →  Hi (Burst Shooting Interval) → desired mode

<input checked="" type="checkbox"/>	 Hi (High)	Shoots up to 10 images per second in succession.
<input type="checkbox"/>	 Lo (Low)	Shoots up to 2 images per second in succession.

Notes

- In slow shutter speed conditions, the burst of shots per second may be decreased.

Related Topic

[Burst Settings](#)

[▲ Back to top](#)

[→ Contents list](#)

- ▶ Operation Search
- ▶ Before Use
- ▶ Shooting
- ▶ Viewing
- ▶ Using 3D Functions
- ▶ Using MENU items (Shooting)
- ▶ Using MENU items (Viewing)
- ▶ Changing settings
- ▶ Viewing images on a TV
- ▶ Using with your computer
- ▶ Printing
- ▶ Troubleshooting
- ▶ Precautions/About this camera

[→ Contents list](#)

Scene Recognition

▼ Advanced mode

The camera automatically detects shooting conditions, and then takes the shot. When a motion is detected, the ISO sensitivity is increased according to the movement to reduce subject blur. When the camera is set to Intelligent Auto mode, you can select [Advanced] mode, in which the camera automatically shoots two images.





In Scene Recognition, the position of an icon displayed on the LCD screen is different depending on the circumstances. It depends on whether the camera recognizes a scene or condition. If the camera recognizes a scene, icons and guides such as (Portrait), (Infant), (Twilight Portrait), (Twilight), (Backlight Portrait), (Backlight), (Landscape), (Macro), (Spotlight) or (Low Light) are displayed on the first line. If the camera recognizes a condition, icons such as (Tripod) or (Move) are displayed on the second line. The camera may recognize both the scene and condition, or just one.

1. MENU → (Scene Recognition) → desired mode







	(Auto)	When the camera recognizes the scene, it switches to the optimal settings and shoots the image.
	(Advanced)	<p>When the camera recognizes the scene, it switches to the optimal settings. When the camera recognizes (Twilight), (Twilight Portrait), (Backlight) or (Backlight Portrait), it automatically changes the setting and shoots another image.</p> <ul style="list-style-type: none"> • When you shoot two images consecutively, the + mark on the icon will turn green. • When two frames are shot, the two images are displayed side by side immediately after shooting. • When [Anti Blink] is displayed, 2 images are taken automatically and the image with the eyes open is selected automatically. [Details]





Notes

- Scene Recognition function does not operate when you shoot images using digital zoom.
- The available flash settings are [Auto] and [Off].
- These scenes may not be recognized depending on the situation.
- In Tracking focus mode, (Portrait), (Twilight Portrait) or (Backlight Portrait) are not recognized.
- If the environment causes vibrations to be transferred to the camera when (Tripod) and (Twilight) condition are recognized at the same time, (Tripod) conditions may not be recognized.
-

- Sometimes a slow shutter results when  (Tripod) and  (Twilight) condition are recognized at the same time. Keep the camera still during shooting.
- You may not be able to set some MENU items depending on the selected REC mode. For details, see “MENU items not available in some REC modes.” [\[Details\]](#)



Advanced mode

In [Advanced] mode, the camera shoots two images consecutively with the different settings as follows when it recognizes  (Twilight),  (Twilight Portrait),  (Backlight) or  (Backlight Portrait) scenes, which tend to blur or when  (Twilight) and  (Tripod) conditions are recognized at the same time. You can select the desired image from the two images shot.

	First Image*	Second Image
	Shoots in Slow Synchro	Shoots with sensitivity increased and shake reduced
	Shoots in Slow Synchro with the face which the flash strobos on as guide	Shoots with sensitivity increased with the face as guide and shake reduced
	Shoots in Slow Synchro	Shoots with a slower shutter speed without increasing sensitivity
	Shoots with the flash	Shoots with the brightness and contrast of the background adjusted
	Shoots with the face which the flash strobos on as guide	Shoots with the brightness and contrast of the face and the background adjusted

* When [Flash] is set to [Auto].

What is the Anti Blink function?

When set to [Advanced], the camera automatically shoots two images consecutively* when it recognizes  (Portrait) or  (Infant). The camera will select, display, and record the image which the eyes are not blinked automatically. If the eyes are closed in both images, the message “Blinked eye detected” is displayed.

* except when the flash strobos/when the shutter speed is slow.

[▲ Back to top](#)





- ▶ Operation Search
- ▶ Before Use
- ▶ Shooting
- ▶ Viewing
- ▶ Using 3D Functions
- ▶ Using MENU items (Shooting)
- ▶ Using MENU items (Viewing)
- ▶ Changing settings
- ▶ Viewing images on a TV
- ▶ Using with your computer
- ▶ Printing
- ▶ Troubleshooting
- ▶ Precautions/About this camera

[➡ Contents list](#)

Soft Skin Effect

When the Face Detection function is activated, sets whether to use the Soft Skin effect, and the effect level.

1. MENU →  (Soft Skin Effect) → desired mode

✓	 OFF (Off)	Does not use the Soft Skin Effect.
	 Lo (Low)	Adds light Soft Skin Effect.
	 Mid (Mid)	Adds moderate Soft Skin Effect.
	 Hi (High)	Adds strong Soft Skin Effect.

Notes

- The [Soft Skin Effect] may not be visible depending on the subject.
- You may not be able to set some MENU items depending on the selected REC mode. For details, see “MENU items not available in some REC modes.” [\[Details\]](#)

[▲ Back to top](#)

- ▶ Operation Search
- ▶ Before Use
- ▶ Shooting
- ▶ Viewing
- ▶ Using 3D Functions
- ▶ Using MENU items (Shooting)
- ▶ Using MENU items (Viewing)
- ▶ Changing settings
- ▶ Viewing images on a TV
- ▶ Using with your computer
- ▶ Printing
- ▶ Troubleshooting
- ▶ Precautions/About this camera

[→ Contents list](#)

Smile Shutter

When the camera detects a smile, the shutter is released automatically.



1. MENU → 😊 (Smile Shutter) → [On]
2. Wait for a smile to be detected.
When a smile is detected and the smile level exceeds the ◀ point on the indicator, the camera records images automatically.
 - If you press the shutter button during Smile Shutter, the camera shoots the image, and then returns to Smile Shutter mode.

On	Uses the [Smile Shutter] function.
✔ Off	Does not use the [Smile Shutter] function.

💡 Tips for better capturing of smiles



- 1 Do not cover the eyes with the bangs. Do not obscure the face by hat, masks, sunglasses, etc.
- 2 Try to orient the face in front of the camera and be as level as possible. Keep the eyes narrowed.
- 3 Give a clear smile with an open mouth. The smile is easier to detect when the teeth are shown.
 - The shutter operates when any person whose face is being detected smiles.
 -

- You can select or register the priority subject for face detection with [Face Detection]. When the selected face is registered in the camera memory, Smile Detection is performed only for that face. [\[Details\]](#)
- If a smile is not detected, select MENU → [Smile Detection Sensitivity], then set the value to [Slight Smile].

Notes

- Shooting using the Smile Shutter ends automatically when either the memory card or internal memory becomes full.
- Smiles may not be detected correctly depending on the conditions.
- You cannot use the digital zoom function.
- You may not be able to set some functions or MENU items depending on the selected REC mode. For details, see “Functions not available in some REC modes” [\[Details\]](#) and “MENU items not available in some REC modes.” [\[Details\]](#)

Related Topic

[Smile Detection Sensitivity](#)

[▲ Back to top](#)

Copyright 2011 Sony Corporation

Smile Detection Sensitivity

Sets the sensitivity of the Smile Shutter function for detecting smiles.

1. MENU → 😊 (Smile Detection Sensitivity) → desired mode

	😊 (Big Smile)	Detects a big smile.
✓	😊 (Normal Smile)	Detects a normal smile.
	😊 (Slight Smile)	Detects even a slight smile.

Notes

- Smiles may not be detected correctly depending on the conditions.
- You may not be able to set some MENU items depending on the selected REC mode. For details, see “MENU items not available in some REC modes.” [\[Details\]](#)

Related Topic

[Smile Shutter](#)

▶ Operation Search
▶ Before Use
▶ Shooting
▶ Viewing
▶ Using 3D Functions
▶ Using MENU items (Shooting)
▶ Using MENU items (Viewing)
▶ Changing settings
▶ Viewing images on a TV
▶ Using with your computer
▶ Printing
▶ Troubleshooting
▶ Precautions/About this camera

[➡ Contents list](#)

[▲ Back to top](#)

▶ Operation Search
▶ Before Use
▶ Shooting
▶ Viewing
▶ Using 3D Functions
▶ Using MENU items (Shooting)
▶ Using MENU items (Viewing)
▶ Changing settings
▶ Viewing images on a TV
▶ Using with your computer
▶ Printing
▶ Troubleshooting
▶ Precautions/About this camera

[→ Contents list](#)

Face Detection

When the Face Detection function is used, the camera detects the faces of your subjects and adjusts the focus, flash, exposure, white balance and red-eye reduction settings automatically.

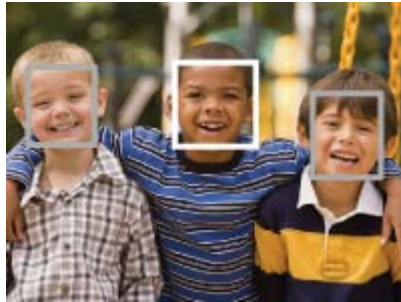

When the camera detects more than one subject, the camera will judge which is the main subject and set focus by priority. The frame for which the focus is set will turn green by pressing the shutter button halfway down.

1. MENU → (Face Detection) → desired mode

	[Off] (Off)	Cannot use Face Detection.
	(Auto)	Selects the face the camera is to automatically focus on.
	(Child Priority)	Detects and shoots with priority on child's face.
	(Adult Priority)	Detects and shoots with priority on adult's face.

Notes

- [Off] is not available when [Self-Timer] is set to [Self-portrait One Person] or [Self-portrait Two People].
- You can select [Face Detection] only when the focus mode is set to [Multi AF] and the metering mode is set to [Multi].
- The Face Detection function does not work when using the digital zoom.
- Up to 8 faces of your subjects can be detected.
- Adults and children may not be recognized correctly depending on the conditions.
- During Smile Shutter shooting, [Face Detection] is automatically set to [Auto] even if it is set to [Off].
- You may not be able to set some MENU items depending on the selected REC mode. For details, see "MENU items not available in some REC modes." [\[Details\]](#)



Related Topic

[Tracking focus](#)



- ▶ Operation Search
- ▶ Before Use
- ▶ Shooting
- ▶ Viewing
- ▶ Using 3D Functions
- ▶ Using MENU items (Shooting)
- ▶ Using MENU items (Viewing)
- ▶ Changing settings
- ▶ Viewing images on a TV
- ▶ Using with your computer
- ▶ Printing
- ▶ Troubleshooting
- ▶ Precautions/About this camera

[➡ Contents list](#)

Anti Blink

When Scene Selection is set to  (Soft Skin) or  (Soft Snap) and the subject blinks while you are shooting an image, the camera automatically shoots two images consecutively. The camera will select, display and record the image which the eyes are not blinked automatically.

1. MENU →  (Anti Blink) → desired mode

	 (Auto)	When Face Detection is active, the Anti Blink function operates so that images with the subject's eyes open are recorded.
	 (Off)	Does not use the Anti Blink function.

Notes

- Anti Blink does not function in the following situations:
 - When using the flash
 - During burst shooting
 - When the Face Detection function does not work
 - When the Smile Shutter function is activated
- Sometimes the Anti Blink function does not work depending on the situation.
- When the Anti Blink function is set to [Auto] but only images with the subject's eyes closed are recorded, the message "Blinked eye detected" is displayed on the LCD screen. Shoot again as necessary.

Related Topic

[Scene Selection](#)

[▲ Back to top](#)

▶ Operation Search
▶ Before Use
▶ Shooting
▶ Viewing
▶ Using 3D Functions
▶ Using MENU items (Shooting)
▶ Using MENU items (Viewing)
▶ Changing settings
▶ Viewing images on a TV
▶ Using with your computer
▶ Printing
▶ Troubleshooting
▶ Precautions/About this camera

[→ Contents list](#)

In-Camera Guide

This camera contains an internal function guide. This allows you to search the camera's functions according to your needs.

You can use the selected function after reading the guide.

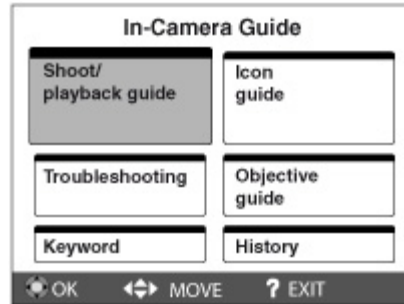

1. MENU → ? (In-Camera Guide)
2. Select a search method from the In-Camera Guide.

Search method	Description
Shoot/ playback guide	Search for various operation functions in shooting/viewing mode.
Icon guide	Search the function and meaning of displayed icons.
Troubleshooting	Search common problems and their solution.
Objective guide	Search functions according to your needs.
Keyword	Search functions by key words.
History	Display the last 12 items displayed in [In-Camera Guide].

[▲ Back to top](#)

MENU items not available in some REC modes

In the table below, ✓ indicates settings that can be changed, while — indicates settings that cannot be changed. The icons below **SCN** indicate the available modes. A setting may be fixed or restricted depending on the shooting mode. For details, see each topic.

Mode Switch										
Menu items			P		SCN					SCN
REC Mode	✓	✓	✓	✓	✓	✓	—	—	—	—
Movie shooting scene	—	—	—	—	—	—	—	—	✓	✓
Panorama Shooting Scene	—	—	—	—	—	—	✓	✓	✓	—
Scene Selection	—	—	—	—	✓	—	—	—	—	✓
Easy Mode	✓	✓	✓	✓	✓	✓	—	—	—	—
Defocus Effect	—	—	—	—	—	✓	—	—	—	—
Still Image Size	✓	✓	✓	✓	✓	✓	—	—	—	—
Panorama Image Size	—	—	—	—	—	—	✓	✓	—	—
Movie Quality	✓	✓	✓	✓	✓	✓	✓	✓	✓	✓
Movie Size	✓	✓	✓	✓	✓	✓	✓	✓	✓	✓
EV	✓	✓	✓	✓		✓	✓	✓	✓	✓
ISO	—	—	✓	—	—	—	—	—	—	—
White Balance*1	—	—	✓	—		—	✓	✓	✓	—
Focus	—	—	✓	—		—	✓	✓	✓	—
Metering Mode	—	—	✓	—		—	✓	✓	✓	—
Burst Shooting Interval	✓	—	✓	—		—	—	—	—	—
Scene Recognition	✓	—	—	—	—	—	—	—	—	—
Soft Skin	—	—	—	—		✓	—	—	—	—

[→ Contents list](#)

Effect*2	-	-	-	-			-	-	-	-	-
Smile Shutter	✓	-	✓	-		-	-	-	-	✓	
Smile Detection Sensitivity	✓	-	✓	-		-	-	-	-	✓	
Face Detection*3	✓	✓	✓	✓		✓	-	-	-	✓	
Anti Blink	-	-	-	-		-	-	-	-	-	-
In-Camera Guide	✓	✓	✓	✓	✓	✓	✓	✓	✓	✓	✓
(Settings)	✓	✓	✓	✓	✓	✓	✓	✓	✓	✓	✓

*1 [Flash] cannot be selected for [White Balance] when Scene Selection is set to (Anti Motion Blur), (Hand-held Twilight) or (High Sensitivity).

*2 [Off] cannot be selected for [Soft Skin Effect] when Scene Selection is set to (Soft Skin).

*3 [Off] cannot be selected for [Face Detection] when Scene Selection is set to (Soft Skin) or (Soft Snap).

Note

- Only the items that are available for each mode are displayed on the screen.

[▲ Back to top](#)

- ▶ Operation Search
- ▶ Before Use
- ▶ Shooting
- ▶ Viewing
- ▶ Using 3D Functions
- ▶ Using MENU items (Shooting)
- ▶ Using MENU items (Viewing)
- ▶ Changing settings
- ▶ Viewing images on a TV
- ▶ Using with your computer
- ▶ Printing
- ▶ Troubleshooting
- ▶ Precautions/About this camera



[→ Contents list](#)

Using MENU items (Viewing)

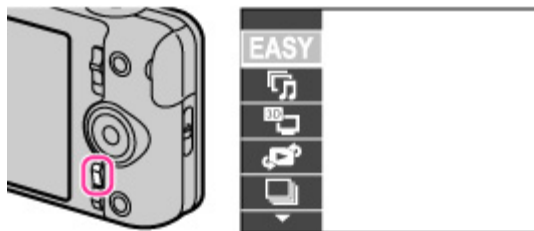

You can select the various viewing functions easily from the MENU button.

1. Press the  (Playback) button to switch to playback mode.
2. Press the MENU button to display the Menu screen.

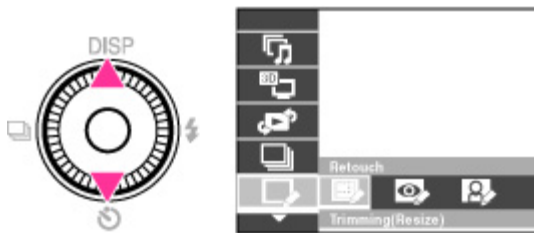

3. Select the desired menu item with  /  on the control wheel.



4. Select the desired item with  /  on the control wheel or by turning the control wheel.

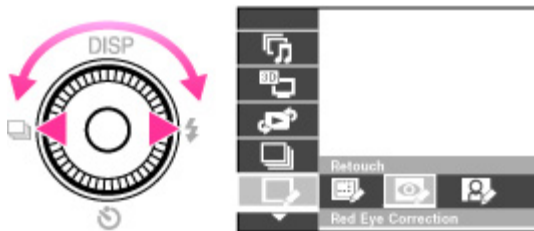

5. Press  in the center of the control wheel to execute the function.

[▲ Back to top](#)

▶ Operation Search
▶ Before Use
▶ Shooting
▶ Viewing
▶ Using 3D Functions
▶ Using MENU items (Shooting)
▶ Using MENU items (Viewing)
▶ Changing settings
▶ Viewing images on a TV
▶ Using with your computer
▶ Printing
▶ Troubleshooting
▶ Precautions/About this camera

[→ Contents list](#)

Easy Mode

When viewing still images in Easy Mode, the playback screen text becomes larger, and indicators become easier to see.

1. Press the  (Playback) button to switch to playback mode.
2. MENU → **EASY** (Easy Mode) → [OK] → ● on the control wheel
 - To end Easy Mode, MENU → [Exit Easy Mode].

Notes

- The battery charge is used up more quickly because the screen brightness increases automatically.
- The shooting mode also changes to [Easy Mode].

Viewing functions available in Easy Mode

In Easy Mode, only the deletion function is available.

 (Delete) button	You can delete the currently displayed image. Select [OK] → ● .
MENU button	You can delete the currently displayed image with [1 image], and delete all images in the selected date range or internal memory (if selected) with [All]. Select [Exit Easy Mode] → [OK] to exit Easy Mode.

Note

- When a memory card is inserted in the camera, [View Mode] is set to [Date View].

[▲ Back to top](#)

- ▶ Operation Search
- ▶ Before Use
- ▶ Shooting
- ▶ Viewing
- ▶ Using 3D Functions
- ▶ Using MENU items (Shooting)
- ▶ Using MENU items (Viewing)
- ▶ Changing settings
- ▶ Viewing images on a TV
- ▶ Using with your computer
- ▶ Printing
- ▶ Troubleshooting
- ▶ Precautions/About this camera



[→ Contents list](#)



Slideshow

▼ Continuous Playback

▼ Slideshow with music

Images are automatically played back in succession.

1. Press the  (Playback) button to switch to playback mode.
2. MENU →  (Slideshow) → desired slideshow → ● on the control wheel

 (Continuous Playback)	Starts playback from the currently displayed image. Playback stops at the image just before the starting image.
 (Slideshow with music)	Plays back still images in succession along with effects and music.

Note

- [Slideshow] is not available when [View Mode] is set to [Folder view (MP4)] or [AVCHD view].

Continuous Playback

1. Select the desired image for playing with the control wheel.
2. MENU →  (Slideshow) → [Continuous Playback] → ●

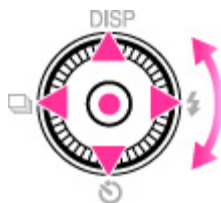





Control wheel	Action
●	Stop
▲	Sets the display settings.
▼	Displays the volume control screen. <ul style="list-style-type: none"> • Adjust the volume using ◀ / ▶ on the control wheel. Press ● to close the volume control screen.
◀	Rewinds image.
▶	Forwards image.

Viewing panoramic images during continuous playback

The whole panoramic image is displayed for 3 seconds.

You can scroll a panoramic image by pressing .

Slideshow with music



1. MENU →  (Slideshow) → [Slideshow with music] →  on the control wheel
Displays the setting screen.
2. Select a desired setting.
3. [Start] → .
4. Press  to end the slideshow.

Note

- [Slideshow with music] is not available for the following images:
 - Panoramic images
 - 3D images recorded in [Standard] or [Wide] size

Playback Selection		
Selects the group of images to be shown. The setting is fixed to [Folder] when the internal memory is used to record images.		
<input checked="" type="checkbox"/>	All	Plays a slideshow of all the images in order.
<input type="checkbox"/>	This Date	Plays a slideshow of images with the currently selected date range when View Mode is [Date View].
<input type="checkbox"/>	Folder	Plays a slideshow of images in the currently selected folder in Folder View.

Effects		
Selects the playback speed and mood for slideshows. If the playback time of movie is long, an image is taken from it and displayed.		
<input checked="" type="checkbox"/>	Simple	A simple slideshow switching images at a preset interval. The playback interval is adjustable in [Interval] and you can thoroughly enjoy your images.
<input type="checkbox"/>	Nostalgic	A moody slideshow reproducing the atmosphere of a movie scene.
<input type="checkbox"/>	Stylish	A stylish slideshow proceeding at a middle tempo.
<input type="checkbox"/>	Active	A high-tempo slideshow suitable for active scenes.

Music		
Specifies the music to be played during slideshows. You can select more than one background music track. Press  on the control wheel to display the volume control screen, then press  /  to adjust the volume.		
<input checked="" type="checkbox"/>	Music1	The default setting for a [Simple] slideshow.
<input type="checkbox"/>	Music2	The default setting for a [Nostalgic] slideshow.
<input type="checkbox"/>	Music3	The default setting for a [Stylish] slideshow.
<input type="checkbox"/>	Music4	The default setting for an [Active] slideshow.

	Muting	Does not use BGM.
--	--------	-------------------

Note

- The movies are played back without their audio.

Interval		
Sets the screen switching interval. The setting is fixed to [Auto] when [Simple] is not selected as the [Effects].		
	1 sec	Sets the display interval of images for a [Simple] slideshow.
<input checked="" type="checkbox"/>	3 sec	
	5 sec	
	10 sec	
	Auto	The interval is set to suit the selected [Effects] item.

 **Selecting background music**

You can transfer a desired music file from your CDs or MP3 files to the camera to play back during slideshow. To transfer music, install the “Music Transfer” software to your computer.

[\[Details\]](#)

- You can record up to four pieces of music on the camera. (The 4 preset pieces (Music1 – Music4) can be replaced with the ones you transferred.)
- The maximum length of each music file for music playback of the camera is about 5 minutes.
- If you cannot play back a music file due to damage or other malfunctions of the file, execute [Empty Music] [\[Details\]](#) and transfer the music again.

Related Topic

[“Music Transfer”](#)

[Installing “PMB” and “Music Transfer” \(Windows\)](#)

[Installing “Music Transfer” \(Macintosh\)](#)



[▲ Back to top](#)

▶ Operation Search
▶ Before Use
▶ Shooting
▶ Viewing
▶ Using 3D Functions
▶ Using MENU items (Shooting)
▶ Using MENU items (Viewing)
▶ Changing settings
▶ Viewing images on a TV
▶ Using with your computer
▶ Printing
▶ Troubleshooting
▶ Precautions/About this camera

[➡ Contents list](#)

3D Viewing

Select [3D Viewing] when you want to play back images shot in 3D mode on the 3D TV. Connect the camera and the 3D TV using an HDMI Cable (sold separately). [\[Details\]](#)

1. Press the  (Playback) button to switch to playback mode.
2. MENU →  (3D Viewing) → ● on the control wheel

Related Topic

[Viewing 3D images on a 3D TV](#)

[▲ Back to top](#)

- ▶ Operation Search
- ▶ Before Use
- ▶ Shooting
- ▶ Viewing
- ▶ Using 3D Functions
- ▶ Using MENU items (Shooting)
- ▶ Using MENU items (Viewing)
- ▶ Changing settings
- ▶ Viewing images on a TV
- ▶ Using with your computer
- ▶ Printing
- ▶ Troubleshooting
- ▶ Precautions/About this camera

[→ Contents list](#)

Send by TransferJet

▼ Receiving images using TransferJet



▼ Using separately sold TransferJet-compatible devices



TransferJet is a close-up, wireless transfer technology that allows data to be transferred by closely aligning two products that you want to communicate with each other.

To find out whether your camera is equipped with the TransferJet function, check for the  (TransferJet) mark on the bottom of the camera.



Using a Memory Stick with TransferJet (sold separately) allows images to be transferred between TransferJet-compatible devices.

For more details on TransferJet, see the operating instructions supplied with Memory Stick with TransferJet.



1. Insert a Memory Stick with TransferJet into the camera.
2. Press the  (Playback) button to switch to playback mode.
3. MENU →  (Send by TransferJet) → desired mode → ● on the control wheel
4. Transfer images by closely aligning the  (TransferJet) marks on the camera and other device.
A notification sound is emitted when connection is made.

 (This Image)	Sends the currently displayed image in single-image mode.
 (Multiple Images)	<p>You can select and send multiple images. After step 3, perform the following.</p> <p>① Select an image then press ● . Repeat the above step until there are no more images to be sent. Select an image with a ✓ mark to release the ✓ mark.</p> <p>② MENU → [OK] → ●</p>

Notes

- Only still images can be transferred.
- Up to 10 images can be transferred at once. However, for 3D images, both the MPO file and the JPEG file are transferred. Depending on the receiving device, up to 20 images are received.
- Set [TransferJet] to [On] in  (Settings). [\[Details\]](#)
- On an airplane, set [TransferJet] to [Off] in  (Settings) [\[Details\]](#). In addition, follow the rules of the place where you use.
- The connection is cut if transfer cannot be made within about 30 seconds. If this happens, select [Yes] and realign the two  (TransferJet) marks on the camera and another device.
- Memory Stick with TransferJet and camera models with TransferJet are not sold in some countries and regions due to local laws and regulations.
- Set the [TransferJet] function to [Off] in countries and regions other than where you purchased your camera. Depending on the country or region, if you use the TransferJet function, you may be liable due to local restrictions on transmission of electromagnetic waves.



Receiving images using TransferJet

1. Press the  (Playback) button to switch to playback mode.
2. Closely align the  (TransferJet) marks on the camera and sending device to receive images.
A notification sound is emitted when connection is made.

Tips for sending and receiving data successfully

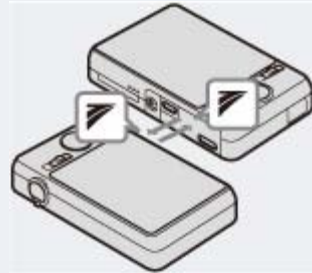
Closely align the  (TransferJet) mark on the camera and other device.



- The transfer rate and range differ depending on the angle at which the  (TransferJet) marks are aligned.
- It may be necessary to alter the position/angle of the camera until communication can be obtained.
- Sending and receiving data is easier if the  (TransferJet) marks are aligned with both cameras parallel to each other as shown in the figure.



Notes

- Only images that can be played back on the camera can be sent or received.
- This camera can receive only JPEG and MPO files.
- If an Image Database File error occurs during saving, a Recover Image Database File screen will appear.
- Play images that cannot be registered in the Image Database File using [Folder view (Still)].

Using separately sold TransferJet-compatible devices

Using separately sold TransferJet-compatible devices allows you to transfer images to a PC and can broaden your enjoyment of transferring data.

For details, see the operating instructions supplied with your TransferJet-compatible device.

- Note the following points when using TransferJet-compatible devices.
 - Before use, set the camera to playback mode.
 - If no image is displayed, press MENU →  (Settings) →  (Main Settings) → [LUN Setting] → [Single].
 - While connected, data cannot be written to or deleted from the camera.
 - Do not disconnect while importing images to “PMB”.

Related Topic

[TransferJet](#)

[TransferJet standard](#)

[▲ Back to top](#)

▶ Operation Search
▶ Before Use
▶ Shooting
▶ Viewing
▶ Using 3D Functions
▶ Using MENU items (Shooting)
▶ Using MENU items (Viewing)
▶ Changing settings
▶ Viewing images on a TV
▶ Using with your computer
▶ Printing
▶ Troubleshooting
▶ Precautions/About this camera



[→ Contents list](#)





View Mode

▼ Displaying the Calendar

▼ Viewing images taken with a different camera

Allows you to select the display format for images.



1. Press the  (Playback) button to switch to playback mode.
2. MENU →  (View Mode) → desired mode → ● on the control wheel

<input checked="" type="checkbox"/>	 (Date View)	Displays images by date.
<input type="checkbox"/>	 (Folder view (Still))	Displays still images.
<input type="checkbox"/>	 (Folder view (MP4))	Displays MP4-format movies.
<input type="checkbox"/>	 (AVCHD view)	Displays AVCHD-format movies.

Note

- When the internal memory is used to record images, View Mode is set to Folder View.

Displaying the Calendar

1. MENU →  (View Mode) → [Date View] → ● on the control wheel
2. Turn the W/T (zoom) lever to W side () repeatedly until the Calendar is displayed.
Use the control wheel to select , then select the month you want to display. Select the date and press ● to view images of the selected date in index mode.

Viewing images taken with a different camera

This camera creates an Image Database File on the memory card for recording and playing images. If the camera detects images not registered in the Image Database File on the memory card, a registration screen with the message “Files found which were not recognized Import files” will be displayed.

To view unregistered images, register them by selecting [OK].

- Use a sufficiently charged battery to register images. If a battery with a low charge is used to register images, it may not be possible to transfer all of the data or the data may be corrupted if the battery charge runs out.



[▲ Back to top](#)



- ▶ Operation Search
- ▶ Before Use
- ▶ Shooting
- ▶ Viewing
- ▶ Using 3D Functions
- ▶ Using MENU items (Shooting)
- ▶ Using MENU items (Viewing)
- ▶ Changing settings
- ▶ Viewing images on a TV
- ▶ Using with your computer
- ▶ Printing
- ▶ Troubleshooting
- ▶ Precautions/About this camera

[➔ Contents list](#)

Display Burst Group

You can select to display burst images in groups or display all images during playback.

1. Press the  (Playback) button to switch to playback mode.
2. MENU →  (View Mode) → [Date View] → ● on the control wheel
3. MENU →  (Display Burst Group) → desired setting → ●

	 (Display Main Image Only)	Groups burst images, then plays back the main image only. <ul style="list-style-type: none"> ● When Face Detection is performed in burst mode, the camera determines and displays the optimum image as the main image. When Face Detection is not performed, the first image in the burst group is displayed as the main image.
	 (Display All)	Plays back all burst images one at a time.

Related Topic

[Viewing burst images](#)



[▲ Back to top](#)







- ▶ Operation Search
- ▶ Before Use
- ▶ Shooting
- ▶ Viewing
- ▶ Using 3D Functions
- ▶ Using MENU items (Shooting)
- ▶ Using MENU items (Viewing)
- ▶ Changing settings
- ▶ Viewing images on a TV
- ▶ Using with your computer
- ▶ Printing
- ▶ Troubleshooting
- ▶ Precautions/About this camera

[→ Contents list](#)

Retouch

Retouches a recorded image and saves it as a new file.
The original image is retained.

1. Press the  (Playback) button to switch to playback mode.
2. MENU →  (Retouch) → desired mode → ● on the control wheel
3. Perform retouching according to the operation method in each mode.

 (Trimming (Resize))	<p>Records the zoomed playback image.</p>  <ol style="list-style-type: none"> ① Turn the W/T (zoom) lever to the T () side to zoom in, and to the W side to zoom out. ② Set the zoom point using ▲ / ▼ / ◀ / ▶ on the control wheel. ③ MENU → select an image size to save → ● ④ [OK] → ● <ul style="list-style-type: none"> ● The quality of trimmed images may deteriorate. ● The image size that you can trim may vary depending on the image.
 (Red Eye Correction)	<p>Corrects the red-eye phenomenon caused by flash.</p>  <p>Select [OK] with the control wheel → ● .</p> <ul style="list-style-type: none"> ● You may not be able to correct the red-eye phenomenon depending on the image.
 (Unsharp masking)	<p>Sharpens the image within a chosen frame.</p>

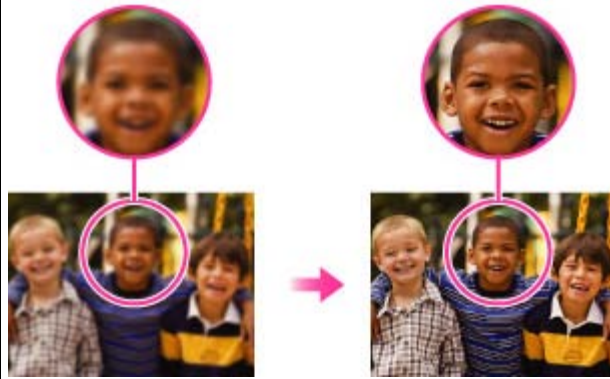

- ① Select the area (frame) of the desired image to retouch using ▲ / ▼ / ◀ / ▶ on the control wheel → MENU.
 - ② [OK] → ●
- Depending on the image, sufficient correction may not be applied and the image quality may deteriorate.

Note

- You cannot retouch the following images:
 - Panoramic images
 - 3D images
 - Movies
 - Images displayed in a burst group



[▲ Back to top](#)







- ▶ Operation Search
- ▶ Before Use
- ▶ Shooting
- ▶ Viewing
- ▶ Using 3D Functions
- ▶ Using MENU items (Shooting)
- ▶ Using MENU items (Viewing)
- ▶ Changing settings
- ▶ Viewing images on a TV
- ▶ Using with your computer
- ▶ Printing
- ▶ Troubleshooting
- ▶ Precautions/About this camera

[→ Contents list](#)

Delete

Allows you to select unwanted images for deletion. You can also delete images using the  (Delete) button. [\[Details\]](#)

1. Press the  (Playback) button to switch to playback mode.
2. MENU →  (Delete) → desired mode → ● on the control wheel
3. [OK] → ●

 (All but This Image)	Deletes burst group images other than the selected image in Display Burst Group mode. Press [OK] → ● after step 2.
 (All Imgs in This Burst Group)	Deletes all images in the selected burst group at once. Press [OK] → ● after step 2.
 (This Image)	Deletes the currently displayed image in single-image mode.
 (Multiple Images)	Allows you to select and delete multiple images. Do as the following after step 2. ① Select an image then press ● . Repeat the above steps until there are no more images to be deleted. Select an image with a ✓ mark again to release the ✓ mark. ② MENU → [OK] → ●
 (All Images on This Date)  (All in This Folder)  (All AVCHD files)	Deletes all images in the selected date range or folder, or all AVCHD movies at once. Press [OK] → ● after step 2.

Notes

- In Easy Mode, you can select from [1 image] or [All].
- When the internal memory is used to record images, View Mode is set to Folder View.

Related Topic

[Delete button](#)

[▲ Back to top](#)



- ▶ Operation Search
- ▶ Before Use
- ▶ Shooting
- ▶ Viewing
- ▶ Using 3D Functions
- ▶ Using MENU items (Shooting)
- ▶ Using MENU items (Viewing)
- ▶ Changing settings
- ▶ Viewing images on a TV
- ▶ Using with your computer
- ▶ Printing
- ▶ Troubleshooting
- ▶ Precautions/About this camera





[→ Contents list](#)

Protect

▼ To cancel the protection

Protects recorded images against accidental erasure. The  mark is displayed for registered images.

1. Press the  (Playback) button to switch to playback mode.
2. MENU →  (Protect) → desired mode → ● on the control wheel

 (This Image)	Protects the currently displayed image in single-image mode.
 (Multiple Images)	<p>You can select and protect multiple images. Do as the following after step 2.</p> <p>① Select an image then press ● . Repeat the above steps until there are no more images to be protected. Select an image with a ✓ mark to release the ✓ mark.</p> <p>② MENU → [OK] → ●</p>
 (Set All Burst Images.)	<p>Protect all images in the selected burst group at once in Display Burst Group mode.</p> <p>Press [OK] → ● after step 2.</p>
 (Remove All Burst Images.)	<p>Release all protected images in the selected burst group at once in Display Burst Group mode.</p> <p>Press [OK] → ● after step 2.</p>

Note

- When the internal memory is used to record images, View Mode is set to Folder View.

▼ To cancel the protection

Select the image for which you want to cancel protection, and unlock it by pressing ● on the control wheel as the same procedure to protect it. The  indicator disappears, and the protection is released.

[▲ Back to top](#)

▶ Operation Search
▶ Before Use
▶ Shooting
▶ Viewing
▶ Using 3D Functions
▶ Using MENU items (Shooting)
▶ Using MENU items (Viewing)
▶ Changing settings
▶ Viewing images on a TV
▶ Using with your computer
▶ Printing
▶ Troubleshooting
▶ Precautions/About this camera

[→ Contents list](#)



Print (DPOF)

▼ Clearing the DPOF mark

DPOF (Digital Print Order Format) is a function that allows you to specify the images of the memory card that you want to print out later.

The **DPOF** (Print order) mark is displayed for registered images.

1. Press the  (Playback) button to switch to playback mode.
2. MENU → Print (DPOF) → desired mode → ● on the control wheel

 (This Image)	Orders printing the currently displayed image in single-image mode.
 (Multiple Images)	<p>You can select and order printing multiple images. Do as the following, after step 2.</p> <p>① Select an image then press ● . Repeat the above steps until there are no more images to be printed. Select an image with a ✓ mark to release the ✓ mark.</p> <p>② MENU → [OK] → ●</p>

Notes

- The **DPOF** (Print order) mark cannot be added to the following images:
 - Movies
 - Images in the internal memory
- You can add a **DPOF** (Print order) mark to a maximum 999 images.

Clearing the DPOF mark

Select the image to clear the DPOF registration, then press ● on the control wheel in the same procedure as when making a **DPOF** mark. The **DPOF** mark disappears and the DPOF registration is cleared.

Related Topic

[Printing still images](#)[▲ Back to top](#)



▶ Operation Search
▶ Before Use
▶ Shooting
▶ Viewing
▶ Using 3D Functions
▶ Using MENU items (Shooting)
▶ Using MENU items (Viewing)
▶ Changing settings
▶ Viewing images on a TV
▶ Using with your computer
▶ Printing
▶ Troubleshooting
▶ Precautions/About this camera

[→ Contents list](#)

Rotate

Rotates a still image. Use this to display a horizontal orientation image in vertical orientation.



1. Press the  (Playback) button to switch to playback mode.
2. MENU →  (Rotate) → ● on the control wheel
3. Press ● on the control wheel.
The still image will be rotated counter-clockwise.
If you want to rotate the image again, repeat step 3.

Notes

- You cannot rotate the following images:
 - 3D images
 - Movies
 - Images displayed in a burst group
- You may not be able to rotate images shot with other cameras.
- When viewing images on a computer, the image rotation information may not be reflected depending on the software.

[▲ Back to top](#)

- ▶ Operation Search
- ▶ Before Use
- ▶ Shooting
- ▶ Viewing
- ▶ Using 3D Functions
- ▶ Using MENU items (Shooting)
- ▶ Using MENU items (Viewing)
- ▶ Changing settings
- ▶ Viewing images on a TV
- ▶ Using with your computer
- ▶ Printing
- ▶ Troubleshooting
- ▶ Precautions/About this camera

[→ Contents list](#)

In-Camera Guide

This camera contains an internal function guide. This allows you to search the camera's functions according to your needs.

You can use the selected function after reading the guide.

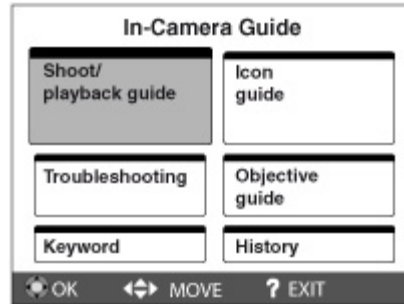

1. MENU → ? (In-Camera Guide)
2. Select a search method from [In-Camera Guide].















Search method	Description
Shoot/ playback guide	Search for various operation functions in shooting/viewing mode.
Icon guide	Search the function and meaning of displayed icons.
Troubleshooting	Search common problems and their solution.
Objective guide	Search functions according to your needs.
Keyword	Search functions by key words.
History	Display the last 12 items displayed in [In-Camera Guide].

[▲ Back to top](#)

[Top page](#) > [Using MENU items \(Viewing\)](#) > [Playback MENU list](#) > [MENU items that cannot be set according to View Mode](#)

MENU items that cannot be set according to View Mode

In the table below, ✓ indicates a user-changeable function, while — indicates an unchangeable one.

Menu items	Memory card				Internal Memory
	 Date View	 Folder view (Still)	 MP4 Folder view (MP4)	 AVCHD AVCHD view	Folder View
 (Slideshow)	✓	✓	—	—	✓
 (3D Viewing)	✓	✓	—	—	✓
 (Send by TransferJet)	✓	✓	—	—	—
 (View Mode)	✓	✓	✓	✓	—
 (Display Burst Group)	✓	—	—	—	—
 (Retouch)	✓	✓	—	—	✓
 (Delete)	✓	✓	✓	✓	✓
 (Protect)	✓	✓	✓	✓	✓
Print (DPOF)	✓	✓	—	—	—
 (Rotate)	✓	✓	—	—	✓
 (In-Camera Guide)	✓	✓	✓	✓	✓
 (Settings)	✓	✓	✓	✓	✓

Note

- Only the items that are available for each mode are displayed on the screen.

[▲ Back to top](#)

- ▶ Operation Search
- ▶ Before Use
- ▶ Shooting
- ▶ Viewing
- ▶ Using 3D Functions
- ▶ Using MENU items (Shooting)
- ▶ Using MENU items (Viewing)
- ▶ Changing settings
- ▶ Viewing images on a TV
- ▶ Using with your computer
- ▶ Printing
- ▶ Troubleshooting
- ▶ Precautions/About this camera

[→ Contents list](#)

- ▶ Operation Search
- ▶ Before Use
- ▶ Shooting
- ▶ Viewing
- ▶ Using 3D Functions
- ▶ Using MENU items (Shooting)
- ▶ Using MENU items (Viewing)
- ▶ Changing settings
- ▶ Viewing images on a TV
- ▶ Using with your computer
- ▶ Printing
- ▶ Troubleshooting
- ▶ Precautions/About this camera





[→ Contents list](#)

Changing camera settings

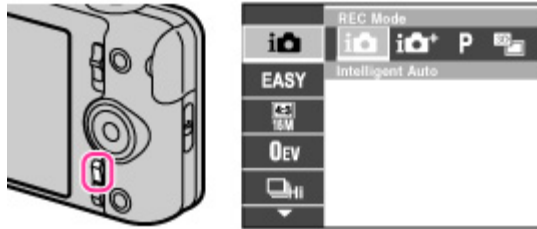
You can change the settings on the  (Settings) screen.

1. Press the MENU button to display the Menu screen.



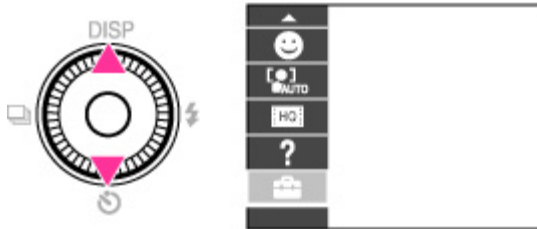

2. Select  (Settings) with  /  on the control wheel, then press  on the control wheel to display the setup screen.

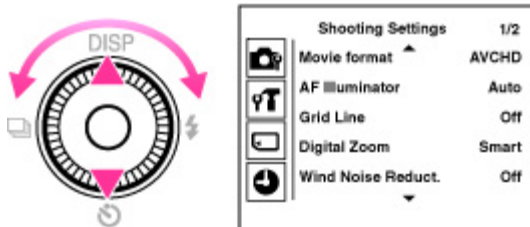

3. Select the desired category by using  /  on the control wheel or turning the control wheel, then press .



4. Select the desired item by using  /  on the control wheel or turning the control wheel, then press .

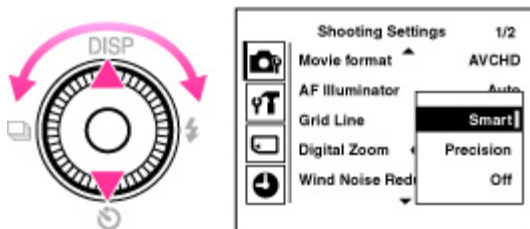

5. Select the desired setting, then press .

Notes

- [Shooting Settings] appears only when settings have been entered from shooting mode.

- [Memory Card Tool] appears only when a memory card is inserted in the camera, while [Internal Memory Tool] appears only when a memory card is not inserted.

[▲ Back to top](#)



Copyright 2011 Sony Corporation

▶ Operation Search
▶ Before Use
▶ Shooting
▶ Viewing
▶ Using 3D Functions
▶ Using MENU items (Shooting)
▶ Using MENU items (Viewing)
▶ Changing settings
▶ Viewing images on a TV
▶ Using with your computer
▶ Printing
▶ Troubleshooting
▶ Precautions/About this camera

[➡ Contents list](#)

Movie format

You can set the recording method used to record movies.

1. Set the camera to shooting mode.
2. MENU →  (Settings) →  (Shooting Settings) → [Movie format] → desired mode
→ ●

<input checked="" type="checkbox"/>	AVCHD	AVCHD movies are recorded. Sets the recording method to AVCHD, which is suitable for viewing smooth video images on a high-definition television. Blu-ray discs, AVCHD discs and DVD-Video discs can be created using the supplied software "PMB". However, AVCHD discs cannot be created from movies recorded in [AVC HD 24M (FX)] quality. Save [AVC HD 24M (FX)] quality movies to Blu-ray discs.
<input type="checkbox"/>	MP4	MP4 (AVC) movies are recorded. Sets the recording method to MP4, which is suitable for WEB uploads and e-mail attachments. No discs can be created from MP4 movies, even if you use the supplied software "PMB".

Related Topic



[AVCHD format](#)[▲ Back to top](#)

▶ Operation Search
▶ Before Use
▶ Shooting
▶ Viewing
▶ Using 3D Functions
▶ Using MENU items (Shooting)
▶ Using MENU items (Viewing)
▶ Changing settings
▶ Viewing images on a TV
▶ Using with your computer
▶ Printing
▶ Troubleshooting
▶ Precautions/About this camera

[→ Contents list](#)





AF Illuminator

The AF illuminator supplies fill light to focus more easily on a subject in dark surroundings. The AF illuminator emits red light allowing the camera to focus easily when the shutter button is pressed halfway, until the focus is locked. The **AF-ON** indicator appears at this time.

1. Set the camera to shooting mode.
2. MENU →  (Settings) →  (Shooting Settings) → [AF Illuminator] → desired mode → ●

<input checked="" type="checkbox"/>	Auto	Uses the AF illuminator.
<input type="checkbox"/>	Off	Does not use the AF illuminator.

Notes

- Focus is achieved as long as the AF illuminator light reaches the subject, regardless of whether light fails to reach the center of the subject.
- You cannot use the AF illuminator in the following situations:
 - In movie mode
 - In Intelligent Sweep Panorama mode
 - When  (Landscape),  (Twilight),  (Pet) or  (Fireworks) mode is selected in Scene Selection.
 - When [Self-Timer] is set to [Self-portrait One Person] or [Self-portrait Two People].
- When you use the AF illuminator, the normal AF range finder frame is disabled and a new AF range finder frame is displayed by a dotted line. AF operates with priority on subjects located near the center of the frame.
- The AF illuminator emits very bright light. Although there is no health hazard, do not look directly into the AF illuminator emitter at close range.



[▲ Back to top](#)

- ▶ Operation Search
- ▶ Before Use
- ▶ Shooting
- ▶ Viewing
- ▶ Using 3D Functions
- ▶ Using MENU items (Shooting)
- ▶ Using MENU items (Viewing)
- ▶ Changing settings
- ▶ Viewing images on a TV
- ▶ Using with your computer
- ▶ Printing
- ▶ Troubleshooting
- ▶ Precautions/About this camera

[➔ Contents list](#)

Grid Line

With reference to the grid lines, you can easily set a subject in a horizontal/vertical position.

1. Set the camera to shooting mode.
2. MENU →  (Settings) →  (Shooting Settings) → [Grid Line] → desired mode →



	On	Displays the grid lines. The grid lines are not recorded.
<input checked="" type="checkbox"/>	Off	Does not display the grid lines.

[▲ Back to top](#)



▶ Operation Search
▶ Before Use
▶ Shooting
▶ Viewing
▶ Using 3D Functions
▶ Using MENU items (Shooting)
▶ Using MENU items (Viewing)
▶ Changing settings
▶ Viewing images on a TV
▶ Using with your computer
▶ Printing
▶ Troubleshooting
▶ Precautions/About this camera

[→ Contents list](#)

Digital Zoom

▼ Total zoom scale when using Smart zoom (including optical zoom 5×)

Selects the digital zoom mode. The camera enlarges the image using optical zoom (up to 5×). When the zoom scale is exceeded, the camera uses either smart or precision digital zoom.

1. Set the camera to shooting mode.
2. MENU →  (Settings) →  (Shooting Settings) → [Digital Zoom] → desired mode
→ ●

<input checked="" type="checkbox"/>	Smart (sQ)	Enlarges the image digitally within the range where the image will not be distorted, according to the image size (Smart zoom).
<input type="checkbox"/>	Precision (PQ)	Enlarges all image sizes by the total zoom scale of approximately 20×, including the optical zoom 5×. However, note that the image quality deteriorates when the optical zoom scale is exceeded (Precision digital zoom).
<input type="checkbox"/>	Off	Does not use the digital zoom.

Notes

- The Digital Zoom function does not operate in the following situations:
 - In Intelligent Sweep Panorama mode
 - When the Smile Shutter function is activated.
 - When [Self-Timer] is set to [Self-portrait One Person] or [Self-portrait Two People].
- The Smart zoom is not available when the image size is set to [16M] or [16:9(12M)].
- The Smart zoom is not available when recording movies.
- The Face Detection function does not work when using the digital zoom.

■ Total zoom scale when using Smart zoom (including optical zoom 5×)

The supported zoom ratio differs depending on the image size.

Size	Total zoom scale
10M	Approx. 6.3×
5M	Approx. 8.9×
VGA	Approx. 36×
16:9(2M)	Approx. 12×



[▲ Back to top](#)

- ▶ Operation Search
- ▶ Before Use
- ▶ Shooting
- ▶ Viewing
- ▶ Using 3D Functions
- ▶ Using MENU items (Shooting)
- ▶ Using MENU items (Viewing)
- ▶ Changing settings
- ▶ Viewing images on a TV
- ▶ Using with your computer
- ▶ Printing
- ▶ Troubleshooting
- ▶ Precautions/About this camera

[➔ Contents list](#)

Wind Noise Reduct.

Reduces the noise of the wind when shooting movies.

1. Set the camera to shooting mode.
2. MENU →  (Settings) →  (Shooting Settings) → [Wind Noise Reduct.] → desired mode → ●

<input type="checkbox"/>	On	Reduces the noise of the wind.
<input checked="" type="checkbox"/>	Off	Does not reduce the noise of the wind.

Note

- If [Wind Noise Reduct.] is set to [On] even though the wind is not blowing strongly, the recorded sounds other than the wind may be hard to hear.



[▲ Back to top](#)

- ▶ Operation Search
- ▶ Before Use
- ▶ Shooting
- ▶ Viewing
- ▶ Using 3D Functions
- ▶ Using MENU items (Shooting)
- ▶ Using MENU items (Viewing)
- ▶ Changing settings
- ▶ Viewing images on a TV
- ▶ Using with your computer
- ▶ Printing
- ▶ Troubleshooting
- ▶ Precautions/About this camera

➔ Contents list

Red Eye Reduction

The flash strobos two or more times before shooting to reduce the red-eye phenomenon when using the flash.

1. Set the camera to shooting mode.
2. MENU →  (Settings) →  (Shooting Settings) → [Red Eye Reduction] → desired mode → ●

✔	Auto	When the Face Detection function is activated, the flash strobos automatically to reduce the red-eye phenomenon.
	On	The flash always strobos to reduce the red-eye phenomenon.
	Off	Does not use Red Eye Reduction.

What causes the red-eye phenomenon?



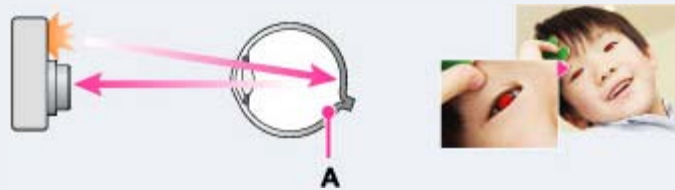



Pupils become dilated in dark environments. Flash light is reflected off the blood vessels at the back of the eye (retina) (A), causing the “red-eye” phenomenon.



Other ways to reduce red-eye

- Select  (High Sensitivity) mode in Scene Selection. (The flash is set to [Off] automatically.)
- When the eyes of the subject turn out red, correct the image with [Retouch] → [Red Eye Correction] on the viewing menu or with the supplied software “PMB”.

Notes



- To avoid blurring of images, hold the camera firmly until the shutter is released. It usually takes a second until the shutter is released, and also be sure not to allow the subject to move during this period.
- Red Eye Reduction may not produce the desired effects. It depends on individual differences and conditions, such as distance to the subject, or if the subject looked away from the pre-strobe.
- If you do not use the Face Detection function, Red Eye Reduction does not work, even when you select [Auto].
- [Red Eye Reduction] is set to [Off] in the following situations:
 - In Background Defocus mode
 - In 3D shooting mode
 - When  (Anti Motion Blur),  (Hand-held Twilight),  (High Sensitivity),  (Gourmet),  (Pet) or  (Fireworks) mode is selected in Scene Selection.
 - When Smile Shutter function is activated.

- ▶ Operation Search
- ▶ Before Use
- ▶ Shooting
- ▶ Viewing
- ▶ Using 3D Functions
- ▶ Using MENU items (Shooting)
- ▶ Using MENU items (Viewing)
- ▶ Changing settings
- ▶ Viewing images on a TV
- ▶ Using with your computer
- ▶ Printing
- ▶ Troubleshooting
- ▶ Precautions/About this camera

[➡ Contents list](#)

Blink Alert

When an image with the subject's eyes closed is recorded while Face Detection is activated, the message "Blinked eye detected" is displayed.

1. Set the camera to shooting mode.
2. MENU →  (Settings) →  (Shooting Settings) → [Blink Alert] → desired mode →



<input checked="" type="checkbox"/>	Auto	Displays the "Blinked eye detected" message.
<input type="checkbox"/>	Off	Does not display the message.

[▲ Back to top](#)



▶ Operation Search
▶ Before Use
▶ Shooting
▶ Viewing
▶ Using 3D Functions
▶ Using MENU items (Shooting)
▶ Using MENU items (Viewing)
▶ Changing settings
▶ Viewing images on a TV
▶ Using with your computer
▶ Printing
▶ Troubleshooting
▶ Precautions/About this camera





[→ Contents list](#)

Write Date

Sets whether to record a shooting date on the still image.



1. Set the camera to shooting mode.
2. MENU →  (Settings) →  (Shooting Settings) → [Write Date] → desired mode
→ ●

	On ()	Records a shooting date. When [On] is selected, the  mark will appear on the bottom right of the LCD screen while shooting. However, in some shooting modes that cannot record dates on images, the  mark will disappear.
	Off	Does not record a shooting date.

Notes

- You cannot record dates in the following situations:
 - In movie mode
 - When shooting still images while recording a movie (Dual Rec)
 - In burst shooting mode
 - In Easy Mode
 - In 3D shooting mode
 - In Sweep Multi Angle mode
- If you shot images with the date once, you cannot delete the date from the images later.
- The dates are doubly printed, if you set the camera to superimpose the dates when printing.
- The recorded time of the image cannot be superimposed on the image.

[▲ Back to top](#)

- ▶ Operation Search
- ▶ Before Use
- ▶ Shooting
- ▶ Viewing
- ▶ Using 3D Functions
- ▶ Using MENU items (Shooting)
- ▶ Using MENU items (Viewing)
- ▶ Changing settings
- ▶ Viewing images on a TV
- ▶ Using with your computer
- ▶ Printing
- ▶ Troubleshooting
- ▶ Precautions/About this camera

[➔ Contents list](#)

Beep

Selects the sound produced when you operate the camera.

1. MENU →  (Settings) →  (Main Settings) → [Beep] → desired mode → ●

	Shutter	Turns on the shutter sound when you press the shutter button.
<input checked="" type="checkbox"/>	On	Turns on the beep/shutter sound when you press the control wheel/shutter button.
<input type="checkbox"/>	Off	Turns off the beep/shutter sound.

[▲ Back to top](#)



▶ Operation Search
▶ Before Use
▶ Shooting
▶ Viewing
▶ Using 3D Functions
▶ Using MENU items (Shooting)
▶ Using MENU items (Viewing)
▶ Changing settings
▶ Viewing images on a TV
▶ Using with your computer
▶ Printing
▶ Troubleshooting
▶ Precautions/About this camera

[➔ Contents list](#)

Panel Brightness

You can select the LCD brightness from levels 1 to 5. The LCD screen becomes brighter as the number rises.

When you use the camera in bright outside light, select a higher number to see the screen easier.

1. MENU →  (Settings) →  (Main Settings) → [Panel Brightness] → desired mode
→ ●

Notes

- The brighter the LCD screen, the faster the battery pack runs out.
- The LCD screen grows dark if you do not operate the camera while the power is on.
- When the high-temperature indicator () is displayed, the LCD screen may grow dark regardless of the settings. [\[Details\]](#)



[▲ Back to top](#)

- ▶ Operation Search
- ▶ Before Use
- ▶ Shooting
- ▶ Viewing
- ▶ Using 3D Functions
- ▶ Using MENU items (Shooting)
- ▶ Using MENU items (Viewing)
- ▶ Changing settings
- ▶ Viewing images on a TV
- ▶ Using with your computer
- ▶ Printing
- ▶ Troubleshooting
- ▶ Precautions/About this camera

[➡ Contents list](#)

Language Setting

Selects the language to be used in the menu items, warnings and messages.

1. MENU →  (Settings) →  (Main Settings) → [Language Setting] → desired mode
→ ●



[▲ Back to top](#)

- ▶ Operation Search
- ▶ Before Use
- ▶ Shooting
- ▶ Viewing
- ▶ Using 3D Functions
- ▶ Using MENU items (Shooting)
- ▶ Using MENU items (Viewing)
- ▶ Changing settings
- ▶ Viewing images on a TV
- ▶ Using with your computer
- ▶ Printing
- ▶ Troubleshooting
- ▶ Precautions/About this camera

[➔ Contents list](#)

Display color

Sets the color of the screen display.

1. MENU →  (Settings) →  (Main Settings) → [Display color] → desired mode →



<input checked="" type="checkbox"/>	Black	Sets the background color of the LCD screen.
<input type="checkbox"/>	White	
<input type="checkbox"/>	Pink	



[▲ Back to top](#)

- ▶ Operation Search
- ▶ Before Use
- ▶ Shooting
- ▶ Viewing
- ▶ Using 3D Functions
- ▶ Using MENU items (Shooting)
- ▶ Using MENU items (Viewing)
- ▶ Changing settings
- ▶ Viewing images on a TV
- ▶ Using with your computer
- ▶ Printing
- ▶ Troubleshooting
- ▶ Precautions/About this camera

[➡ Contents list](#)

Demo Mode

You can set whether to use a demonstration of Smile Shutter or AVCHD movie playback. When there is no need to view a demonstration, set to [Off].

1. MENU →  (Settings) →  (Main Settings) → [Demo Mode] → desired mode → 

Demo Mode1	A demonstration of the shooting functions will be performed.
Demo Mode2	Automatically starts the Smile Shutter demonstration when no operation is performed for 15 seconds.
Demo Mode3	If no operation is performed for a set period of time while the camera is connected to an HD TV, a demonstration of AVCHD movie playback will automatically be performed.
 Off	Does not perform a demonstration.

Notes

- Pressing the shutter button during the Smile Shutter demonstration operates the shutter, but no image is recorded.
- During a demonstration, if the number of images saved in the internal memory increases, the camera may automatically delete the images. It is recommended to make a backup copy of the images on the internal memory before a demonstration.



[▲ Back to top](#)

▶ Operation Search
▶ Before Use
▶ Shooting
▶ Viewing
▶ Using 3D Functions
▶ Using MENU items (Shooting)
▶ Using MENU items (Viewing)
▶ Changing settings
▶ Viewing images on a TV
▶ Using with your computer
▶ Printing
▶ Troubleshooting
▶ Precautions/About this camera

[→ Contents list](#)

Initialize

Initializes the setting to the default setting.
Even if you execute this function, the images are retained.

1. MENU →  (Settings) →  (Main Settings) → [Initialize] → [OK] → ●

Note

- Be sure not to turn off the camera while initializing.



[▲ Back to top](#)

- ▶ Operation Search
- ▶ Before Use
- ▶ Shooting
- ▶ Viewing
- ▶ Using 3D Functions
- ▶ Using MENU items (Shooting)
- ▶ Using MENU items (Viewing)
- ▶ Changing settings
- ▶ Viewing images on a TV
- ▶ Using with your computer
- ▶ Printing
- ▶ Troubleshooting
- ▶ Precautions/About this camera

[➡ Contents list](#)

Function Guide

You can select whether or not the function guide is displayed when you operate the camera.

1. MENU →  (Settings) →  (Main Settings) → [Function Guide] → desired mode
→ ●

<input checked="" type="checkbox"/>	On	Displays the function guide.
<input type="checkbox"/>	Off	Does not display the function guide.



[▲ Back to top](#)

▶ Operation Search
▶ Before Use
▶ Shooting
▶ Viewing
▶ Using 3D Functions
▶ Using MENU items (Shooting)
▶ Using MENU items (Viewing)
▶ Changing settings
▶ Viewing images on a TV
▶ Using with your computer
▶ Printing
▶ Troubleshooting
▶ Precautions/About this camera

[➡ Contents list](#)

CTRL FOR HDMI

This setting allows (TV) remote control of a camera that is connected to a “BRAVIA” Sync TV using the HDMI Cable (sold separately). [\[Details\]](#)

1. MENU →  (Settings) →  (Main Settings) → [CTRL FOR HDMI] → desired mode
→ ●

<input checked="" type="checkbox"/>	On	Enables remote-controlled operation.
<input type="checkbox"/>	Off	Disables remote-controlled operation.

Note

- You can perform the operation of the camera with the remote controller of your TV by connecting your camera to a “BRAVIA” Sync-compatible TV.

Related Topic

[Viewing an image on a “BRAVIA” Sync-compatible TV](#)



[▲ Back to top](#)

- ▶ Operation Search
- ▶ Before Use
- ▶ Shooting
- ▶ Viewing
- ▶ Using 3D Functions
- ▶ Using MENU items (Shooting)
- ▶ Using MENU items (Viewing)
- ▶ Changing settings
- ▶ Viewing images on a TV
- ▶ Using with your computer
- ▶ Printing
- ▶ Troubleshooting
- ▶ Precautions/About this camera

[➔ Contents list](#)

USB Connect Setting

Selects the USB mode when connecting the camera to a computer or a USB device using the multi-use terminal USB cable.

1. MENU →  (Settings) →  (Main Settings) → [USB Connect Setting] → desired mode → ●

	Auto	Depending on the computer or other USB devices you connect to the camera, the connection mode is automatically selected from [MTP] or [Mass Storage]. When you use Windows 7, [MTP] is selected and Windows 7-specific functions become available.
	MTP	Establishes a MTP connection between the camera and a computer or other USB devices. When you use Windows 7, [MTP] is selected and Windows 7-specific functions become available. When you use other operating systems (Vista/XP, Mac OS X), the AutoPlay Wizard appears, and the still images in the recording folder on the camera are imported to the computer.
	Mass Storage	Establishes a Mass Storage connection between the camera and a computer or other USB device.

Note

- If Device Stage* does not appear when connecting the camera to a Windows 7 computer, set [USB Connect Setting] to [Auto].

* Device Stage is a menu screen to manage connected devices, such as a camera. (Function of Windows 7)



[▲ Back to top](#)

- ▶ Operation Search
- ▶ Before Use
- ▶ Shooting
- ▶ Viewing
- ▶ Using 3D Functions
- ▶ Using MENU items (Shooting)
- ▶ Using MENU items (Viewing)
- ▶ Changing settings
- ▶ Viewing images on a TV
- ▶ Using with your computer
- ▶ Printing
- ▶ Troubleshooting
- ▶ Precautions/About this camera

[➡ Contents list](#)

USB Power Supply

Set whether to use the USB power supplied function when the camera is connected to a computer or a USB device using the multi-use terminal USB cable.

1. MENU →  (Settings) →  (Main Settings) → [USB Power Supply] → desired mode → ●

<input checked="" type="checkbox"/>	On	Power is supplied when connected using the multi-use terminal USB cable.
<input type="checkbox"/>	Off	Disables USB power supplied function even if you connect the camera to a device such as a computer using a multi-use terminal USB cable.

[▲ Back to top](#)

▶ Operation Search
▶ Before Use
▶ Shooting
▶ Viewing
▶ Using 3D Functions
▶ Using MENU items (Shooting)
▶ Using MENU items (Viewing)
▶ Changing settings
▶ Viewing images on a TV
▶ Using with your computer
▶ Printing
▶ Troubleshooting
▶ Precautions/About this camera

[➔ Contents list](#)

LUN Setting

Sets the display method for the recording media displayed on a computer screen or other monitor when the camera is connected with a computer or AV component using a USB connection.

1. MENU →  (Settings) →  (Main Settings) → [LUN Setting] → desired mode →



<input checked="" type="checkbox"/>	Multi	The images both on the memory card and in the internal memory are displayed. Select this setting when you connect the camera to a computer.
<input type="checkbox"/>	Single	When the memory card is inserted into the camera, the images on the memory card are displayed; when it is not inserted, the images in the internal memory are displayed. Select this setting in cases where the images of both the memory card and the internal memory are not displayed when the camera is connected to a device other than a computer.

Note

- Set [LUN Setting] to [Multi] when uploading images to a media service using “PMB Portable”.



[▲ Back to top](#)

▶ Operation Search
▶ Before Use
▶ Shooting
▶ Viewing
▶ Using 3D Functions
▶ Using MENU items (Shooting)
▶ Using MENU items (Viewing)
▶ Changing settings
▶ Viewing images on a TV
▶ Using with your computer
▶ Printing
▶ Troubleshooting
▶ Precautions/About this camera

[➡ Contents list](#)

Download Music

You can change background music tracks using “Music Transfer”.

1. MENU →  (Settings) →  (Main Settings) → [Download Music] → ●

The message “Connect to PC” is displayed.

2. Make a USB connection between the camera and a computer, then start “Music Transfer”.
3. Follow the instructions on the screen to change music files.

[▲ Back to top](#)

▶ Operation Search
▶ Before Use
▶ Shooting
▶ Viewing
▶ Using 3D Functions
▶ Using MENU items (Shooting)
▶ Using MENU items (Viewing)
▶ Changing settings
▶ Viewing images on a TV
▶ Using with your computer
▶ Printing
▶ Troubleshooting
▶ Precautions/About this camera

[➡ Contents list](#)

Empty Music

You can delete all the background music files stored in the camera. It can be used in cases such as when the background music files are damaged and cannot be played.

1. MENU →  (Settings) →  (Main Settings) → [Empty Music] → [OK] → ●

Restoring the music preset at the factory to the camera

You can use “Music Transfer” to reset music files to the preset ones. For details on using “Music Transfer”, see the help in “Music Transfer”.

1. Execute [Download Music], then make a USB connection between the camera and a computer.
2. Start “Music Transfer”, then restore the default music.

[▲ Back to top](#)

- ▶ Operation Search
- ▶ Before Use
- ▶ Shooting
- ▶ Viewing
- ▶ Using 3D Functions
- ▶ Using MENU items (Shooting)
- ▶ Using MENU items (Viewing)
- ▶ Changing settings
- ▶ Viewing images on a TV
- ▶ Using with your computer
- ▶ Printing
- ▶ Troubleshooting
- ▶ Precautions/About this camera

[→ Contents list](#)

TransferJet

You can select TransferJet communication settings. TransferJet is a close-up, wireless transfer technology that allows data to be transferred by closely aligning two products that you want to communicate with each other. To find out whether your camera is equipped with the TransferJet function, check for the  (TransferJet) mark on the bottom of the camera.

Using a Memory Stick with TransferJet (sold separately) allows images to be transferred between TransferJet-compatible devices.

For more details on TransferJet, see the Operating Instructions supplied with Memory Stick with TransferJet.

1. MENU →  (Settings) →  (Main Settings) → [TransferJet] → desired mode →

<input checked="" type="checkbox"/>	On	Communicates using TransferJet.
<input type="checkbox"/>	Off	Does not communicate using TransferJet.

What is TransferJet?

TransferJet allows you to share images by sending and receiving image data. Insert a Memory Stick with TransferJet in your camera and align two  (TransferJet) marks of the camera and another device that supports this function.

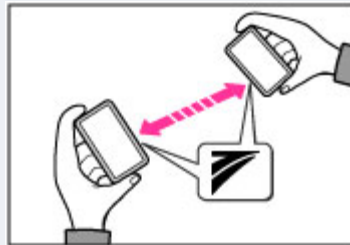

For details on image transfer, see [\[Details\]](#).

Notes

- In Easy Mode, [TransferJet] is fixed to [Off].
- While aboard an airplane, set [TransferJet] to [Off]. In addition, always follow all regulations governing the location in which the camera is being used.
- The connection is cut if transfer cannot be made within about 30 seconds. If this happens, select [Yes] and again align two  (TransferJet) marks on the camera and another device.
- Memory Stick with TransferJet and camera models with TransferJet are not sold in some countries and regions due to local laws and regulations.
- Set the [TransferJet] function to [Off] in countries and regions other than where you purchased your camera. Depending on the country or region, if you use the TransferJet function, you may be liable due to local restrictions on transmission of electromagnetic waves.

Related Topic

[Send by TransferJet](#)

[TransferJet standard](#)

[▲ Back to top](#)

Copyright 2011 Sony Corporation

- ▶ Operation Search
- ▶ Before Use
- ▶ Shooting
- ▶ Viewing
- ▶ Using 3D Functions
- ▶ Using MENU items (Shooting)
- ▶ Using MENU items (Viewing)
- ▶ Changing settings
- ▶ Viewing images on a TV
- ▶ Using with your computer
- ▶ Printing
- ▶ Troubleshooting
- ▶ Precautions/About this camera

[→ Contents list](#)





Eye-Fi

▼ Transferring image data using the Eye-Fi card

Sets whether to use the upload function of an Eye-Fi card (commercially available), when you use the Eye-Fi card with this camera.

[Eye-Fi] is displayed only when the Eye-Fi card is inserted in the camera.

1. MENU →  (Settings) →  (Main Settings) → [Eye-Fi] → desired mode → ●

✓	On	<p>Uses the upload function. The Eye-Fi mode display icon on the LCD screen will change depending on the communication mode of the Eye-Fi card.</p> <ul style="list-style-type: none"> : Eye-Fi card is in standby mode. There is no image to be sent. : Eye-Fi card is in upload standby mode. : Eye-Fi card is in connecting mode. : Eye-Fi card is uploading images. : An error has occurred.
	Off	Does not use the upload function.

Notes

- As of December 2010, Eye-Fi cards are sold in the U.S.A., Canada, Japan and some countries in the European Union.
- For more information on the Eye-Fi card, contact the manufacturer or seller of Eye-Fi cards directly.
- Eye-Fi cards are permitted only in the countries and regions in which they were purchased. You may be held liable due to local restrictions.
- The Eye-Fi card has a wireless LAN function. Do not insert the Eye-Fi card where wireless LAN is prohibited, such as while aboard an airplane. If the Eye-Fi card is inserted, set [Eye-Fi] to [Off]. When the uploading function of the Eye-Fi card is set to [Off],  is displayed on the LCD screen.

Transferring image data using the Eye-Fi card

1. Set the wireless LAN access point settings or the transferring direction settings of the Eye-Fi card.
For details, refer to the operating instructions supplied with the Eye-Fi card.
2. After the settings are finished, insert the Eye-Fi card into the camera, and shoot the images. The recorded images are automatically transferred via the wireless LAN to the PC, etc.

Notes

- When you use a new Eye-Fi card for the first time, copy the install file of the PC application written in the Eye-Fi card first, then format the card.
- Before using the Eye-Fi card, upgrade the firmware of the Eye-Fi card to the latest version. For details on version upgrades, refer to the operating instructions supplied with the Eye-Fi card.
- When uploading image data, [Power Save] is not available.
- If the  (error) icon is displayed, eject and re-insert the Eye-Fi card, or turn the power of

the camera off and on again. If the  (error) icon is still displayed, the Eye-Fi card may be corrupted. For details, contact Eye-Fi, Inc.

- Wireless LAN communication may be interrupted by the other communication devices. If data reception is insufficient, move the camera closer to the access point.
- For details on content that can be uploaded, refer to the operating instructions supplied with the Eye-Fi card.
- Some Eye-Fi cards have an “Endless Memory Mode.” This product does not support “Endless Memory Mode.” Make sure that Eye-Fi cards that you insert into this product have “Endless Memory Mode” turned off. For details on setting “Endless Memory Mode”, refer to the operating instructions supplied with the Eye-Fi card.

[▲ Back to top](#)

Copyright 2011 Sony Corporation

▶ Operation Search
▶ Before Use
▶ Shooting
▶ Viewing
▶ Using 3D Functions
▶ Using MENU items (Shooting)
▶ Using MENU items (Viewing)
▶ Changing settings
▶ Viewing images on a TV
▶ Using with your computer
▶ Printing
▶ Troubleshooting
▶ Precautions/About this camera

[→ Contents list](#)

Power Save

Sets the length of time until the LCD screen goes dark and the time until the camera turns off. If you do not operate the camera for a certain period of time while the power is on using the battery pack, the screen goes dark and the camera later turns off automatically to prevent wearing down the battery pack (Auto power-off function).

1. MENU →  (Settings) →  (Main Settings) → [Power Save] → desired mode →



	Stamina	Proactively saves the battery power. If the camera is not operated for a certain period of time, the power turns off automatically. In shooting mode, the LCD screen automatically goes dark before the power turns off.
<input checked="" type="checkbox"/>	Standard	If the camera is not operated for a certain period of time, the power turns off automatically. In shooting mode, the LCD screen automatically goes dark before the power turns off. It takes longer before the power turns off than when set to [Stamina].
	Off	Does not use the Auto power-off function.

Note

- The camera does not enter Power Save mode under conditions such as during a slideshow, during movie playback or when the camera is connected to a TV or a computer.

[▲ Back to top](#)



▶ Operation Search
▶ Before Use
▶ Shooting
▶ Viewing
▶ Using 3D Functions
▶ Using MENU items (Shooting)
▶ Using MENU items (Viewing)
▶ Changing settings
▶ Viewing images on a TV
▶ Using with your computer
▶ Printing
▶ Troubleshooting
▶ Precautions/About this camera

[➡ Contents list](#)

Format

Formats the memory card or the internal memory.

When you use a memory card with this camera for the first time, it is recommended to format the card using the camera for stable performance of the memory card before shooting. Note that formatting permanently erases all data on the memory card, and is unrecoverable. Save precious data on a computer, etc.

1. MENU →  (Settings) →  (Memory Card Tool) or  (Internal Memory Tool) → [Format] → [OK] → ●

Note



- Note that formatting permanently erases all data including even protected images.

[▲ Back to top](#)

Create REC.Folder

Creates a folder in a memory card for recording images.

Images are recorded in the newly created folder until you create another folder or select another recording folder.

1. MENU →  (Settings) →  (Memory Card Tool) → [Create REC.Folder] → [OK] → ●

On the folders

After a new folder is created, you can change the storage destination folder. [\[Details\]](#)

Notes

- This item is not displayed when the internal memory is used to record images.
- When you insert a memory card that was used with other equipment into the camera and shoot images, a new folder may be automatically created.
- Up to 4,000 images can be stored in one folder. When the folder capacity is exceeded, a new folder is automatically created.

▶ Operation Search
▶ Before Use
▶ Shooting
▶ Viewing
▶ Using 3D Functions
▶ Using MENU items (Shooting)
▶ Using MENU items (Viewing)
▶ Changing settings
▶ Viewing images on a TV
▶ Using with your computer
▶ Printing
▶ Troubleshooting
▶ Precautions/About this camera



[➡ Contents list](#)

[▲ Back to top](#)

[Top page](#) > [Changing settings](#) > [Memory Card Tool/Internal Memory Tool](#) > [Change REC.Folder](#)

Change REC.Folder

Changes the folder in the memory card that is currently used for recording images.

1. MENU →  (Settings) →  (Memory Card Tool) → [Change REC.Folder]
2. Select a folder with ◀ / ▶ on the control wheel.
3. [OK] → ●

Notes

- This item is not displayed when the internal memory is used to record images.
- You cannot select a folder with a number that has only “□ □ □ MSDCF” or “□ □ □ ANV01” as a recording folder.
- You cannot move recorded images to another folder.

[▲ Back to top](#)



▶ Operation Search
▶ Before Use
▶ Shooting
▶ Viewing
▶ Using 3D Functions
▶ Using MENU items (Shooting)
▶ Using MENU items (Viewing)
▶ Changing settings
▶ Viewing images on a TV
▶ Using with your computer
▶ Printing
▶ Troubleshooting
▶ Precautions/About this camera

[➡ Contents list](#)

Copyright 2011 Sony Corporation

Delete REC.Folder

Deletes a folder for recording images in a memory card.

1. MENU →  (Settings) →  (Memory Card Tool) → [Delete REC.Folder]
2. Select a folder with ◀ / ▶ on the control wheel.
3. [OK] → ●

Notes

- This item is not displayed when the internal memory is used to record images.
- If you delete the folder set as the recording folder using [Delete REC.Folder], the folder that has the largest folder number is selected as the next recording folder.
- If a folder contains protected images or files that cannot be played back by the camera, images other than these images are deleted and the folder will remain.

[▲ Back to top](#)

▶ Operation Search
▶ Before Use
▶ Shooting
▶ Viewing
▶ Using 3D Functions
▶ Using MENU items (Shooting)
▶ Using MENU items (Viewing)
▶ Changing settings
▶ Viewing images on a TV
▶ Using with your computer
▶ Printing
▶ Troubleshooting
▶ Precautions/About this camera



[➡ Contents list](#)

▶ Operation Search
▶ Before Use
▶ Shooting
▶ Viewing
▶ Using 3D Functions
▶ Using MENU items (Shooting)
▶ Using MENU items (Viewing)
▶ Changing settings
▶ Viewing images on a TV
▶ Using with your computer
▶ Printing
▶ Troubleshooting
▶ Precautions/About this camera

[➡ Contents list](#)

Copy

Copies all images in the internal memory to a memory card.

1. Insert a memory card with sufficient free capacity into the camera.
2. MENU →  (Settings) →  (Memory Card Tool) → [Copy] → [OK] → ●

Notes

- Use a fully charged battery pack. If you attempt to copy image files using a battery pack with little remaining charge, the battery pack may run out, causing copying to fail or possibly corrupting the data.
- Images cannot be copied individually.
- The original images in the internal memory are retained even after copying. To delete the contents of the internal memory, remove the memory card after copying, then format the internal memory ([Format] in [Internal Memory Tool]).
- The data will be copied to the recording folder that is currently being used, with a number one higher than the largest data number in that folder. [\[Details\]](#)



[▲ Back to top](#)

- ▶ Operation Search
- ▶ Before Use
- ▶ Shooting
- ▶ Viewing
- ▶ Using 3D Functions
- ▶ Using MENU items (Shooting)
- ▶ Using MENU items (Viewing)
- ▶ Changing settings
- ▶ Viewing images on a TV
- ▶ Using with your computer
- ▶ Printing
- ▶ Troubleshooting
- ▶ Precautions/About this camera

[➡ Contents list](#)

File Number

Selects the method used to assign file numbers to images.

1. MENU →  (Settings) →  (Memory Card Tool) → [File Number] → desired mode
→ ●

<input checked="" type="checkbox"/>	Series	Assigns numbers to files in sequence even if the recording folder or the memory card is changed. (When the replaced memory card contains a file with a number higher than the last assigned number, a number one higher than the largest number is assigned.)
<input type="checkbox"/>	Reset	Starts from 0001 each time the folder is changed. (When the recording folder contains a file, a number one higher than the largest number is assigned.)

[▲ Back to top](#)

▶ Operation Search
▶ Before Use
▶ Shooting
▶ Viewing
▶ Using 3D Functions
▶ Using MENU items (Shooting)
▶ Using MENU items (Viewing)
▶ Changing settings
▶ Viewing images on a TV
▶ Using with your computer
▶ Printing
▶ Troubleshooting
▶ Precautions/About this camera

[→ Contents list](#)

Area Setting

Adjusts the time to the local time of a selected area.

1. MENU →  (Settings) →  (Clock Settings) → [Area Setting] → desired setting →







<input checked="" type="checkbox"/>	Home	You use the camera in your area. When the currently set area differs from your home area, you must make the Area Setting.
<input type="checkbox"/>	Destination	You use the camera set to the time at your destination. Set the destination area.

Changing Area Setting

Setting a frequently visited destination lets you easily adjust the time when you visit that destination.

1. Select the area part for [Destination], then press .



2. Press  /  on the control wheel or turn the control wheel to select the desired area, then select Daylight Savings time using  / .



[▲ Back to top](#)

- ▶ Operation Search
- ▶ Before Use
- ▶ Shooting
- ▶ Viewing
- ▶ Using 3D Functions
- ▶ Using MENU items (Shooting)
- ▶ Using MENU items (Viewing)
- ▶ Changing settings
- ▶ Viewing images on a TV
- ▶ Using with your computer
- ▶ Printing
- ▶ Troubleshooting
- ▶ Precautions/About this camera

[→ Contents list](#)

Date & Time Setting

Sets the date and time again.

1. MENU →  (Settings) →  (Clock Settings) → [Date & Time Setting] → desired setting → ●
2. Select the item to be changed using ▲ / ▼ / ◀ / ▶ on the control wheel.

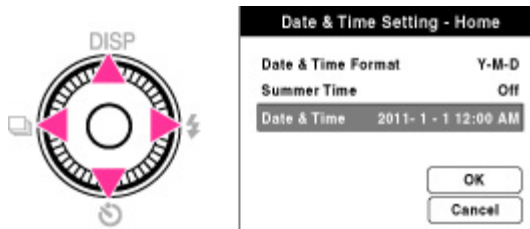

3. Press ▲ / ▼ on the control wheel or turn the control wheel to set the numeric value.

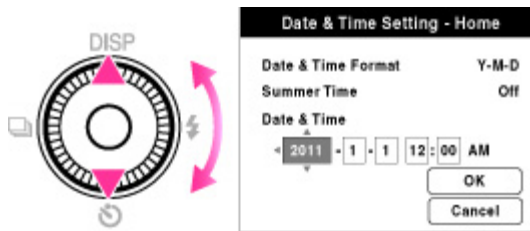

4. [OK] → ●

Date & Time Format	You can select the date and time display format.
Summer Time/Daylight Savings	You can select Daylight Savings [On]/[Off].
Date & Time	You can set the date and time.

[▲ Back to top](#)

[Top page](#) > [Viewing images on a TV](#) > [Viewing an image on a High Definition \(HD\) TV](#) > [Viewing an image on an HD TV using the HDMI Cable \(sold separately\)](#)

Viewing an image on an HD TV using the HDMI Cable (sold separately)

Connect the camera to an HD (High Definition) TV that has an HDMI jack using the HDMI Cable (sold separately).

1. Turn off both the camera and the TV.
2. Connect the HDMI connector of the camera (**A**) and the HDMI jack of the TV (**B**) using an HDMI Cable (sold separately) (**C**).

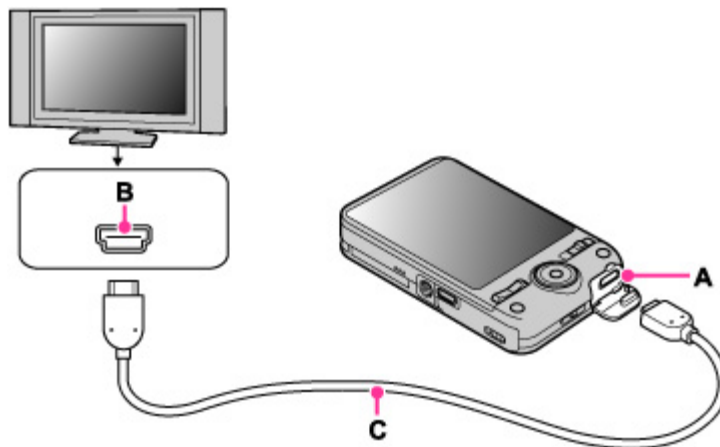

3. Turn on the TV and set the input.
4. Press the  (Playback) button to turn on the camera. Images shot with the camera appear on the TV. Select the desired image with the control wheel.

"PhotoTV HD"

This camera is compatible with the "PhotoTV HD" standard.

By connecting a Sony TV compatible with "PhotoTV HD" using an HDMI Cable (sold separately), a whole new world of photos can be comfortably enjoyed in breathtaking Full HD quality.

- "PhotoTV HD" allows for a highly-detailed, photo-like expression of subtle textures and colors.
- When the camera is connected to a Sony TV compatible with Video A mode using an HDMI Cable, your TV is automatically set to the picture quality suitable for still images. When the setting of the TV is set to Video, the picture quality is set to that suitable for movies.
- When playing back an AVCHD movie, it is recommended that you set [View Mode] to [AVCHD view].
- For details, see the operating instructions of the TV.

Notes

- Images shot in [VGA] image size cannot be played back in the HD format.
- [Beep] is fixed to [Shutter].
- Do not connect the camera and equipment to be connected using both output terminals. When the camera and TV are connected using output terminals, no video or sound are produced. Such a connection can also cause problems with the camera and/or connected

▶ Operation Search
▶ Before Use
▶ Shooting
▶ Viewing
▶ Using 3D Functions
▶ Using MENU items (Shooting)
▶ Using MENU items (Viewing)
▶ Changing settings
▶ Viewing images on a TV
▶ Using with your computer
▶ Printing
▶ Troubleshooting
▶ Precautions/About this camera

[→ Contents list](#)

equipment.

- The camera may not work properly with some HD TVs. For example, you may not be able to view a video on your HD TV or hear sound from the HD TV.
- Use an HDMI Cable with the HDMI logo.
- Use an HDMI mini connector on one end (for the camera), and a connector suitable for connection to your TV on the other end.
- Recording may automatically stop to protect the camera after a period of time if you are shooting movies when the camera and TV are connected by an HDMI Cable (sold separately).

Related Topic

[Viewing 3D images on a 3D TV](#)

[▲ Back to top](#)

Copyright 2011 Sony Corporation

- ▶ Operation Search
- ▶ Before Use
- ▶ Shooting
- ▶ Viewing
- ▶ Using 3D Functions
- ▶ Using MENU items (Shooting)
- ▶ Using MENU items (Viewing)
- ▶ Changing settings
- ▶ Viewing images on a TV
- ▶ Using with your computer
- ▶ Printing
- ▶ Troubleshooting
- ▶ Precautions/About this camera



[→ Contents list](#)

Viewing an image on a “BRAVIA” Sync-compatible TV

When you use a TV that has “BRAVIA” Sync (compatible with SYNC MENU) support, you can operate the playback functions of the camera using the remote controller supplied with the TV by connecting the camera to the TV using an HDMI Cable (sold separately).

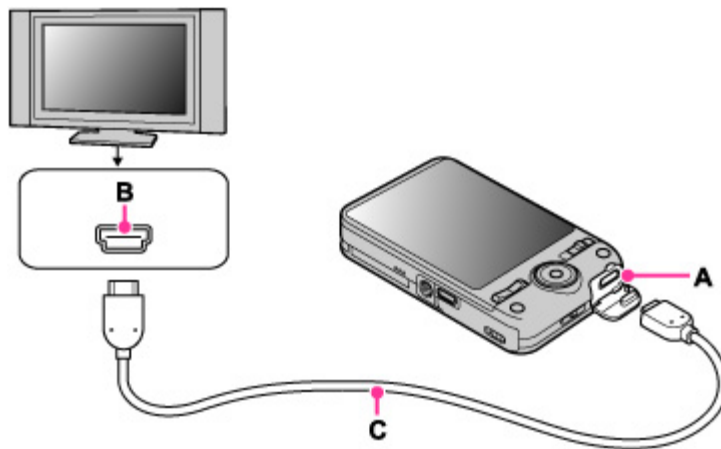
1. Connect the HDMI connector of the camera (A) and the HDMI jack of the TV (B) using an HDMI Cable (sold separately) (C).





2. Turn on the TV and set the input.
3. Press the  (playback) button of the camera to turn on the camera.
4. MENU →  (Settings) →  (Main Settings) → [CTRL FOR HDMI] → [On] → ●
5. Press the SYNC MENU button of the TV’s remote controller to select the desired mode.

Menu	Function
Slideshow with music	Automatically plays back images with sound effects or background music in a continuous loop.
Single Image	Plays back a single image at a time.
Image Index	Displays multiple images at the same time.
3D Viewing	Plays back 3D images recorded in 3D shooting mode.
Delete	Deletes recorded images.
PB Zoom	Plays back enlarged images.
Rotate	Rotates a still image.
View Mode	Selects the display format for viewing multiple images.
Exit	Exits from the playback operations.

Notes

- When the camera is connected to a TV set using an HDMI Cable, the functions that you can operate are limited.

- You can perform the operation of the camera with the remote controller of your TV by connecting your camera to a “BRAVIA” Sync-compatible TV. For details, see the operating instructions of the TV.
- If the camera functions in an undesired manner when you are controlling it using the TV’s remote controller, such as when connected via HDMI to another manufacturer’s TV, press MENU →  (Settings) →  (Main Settings) → [CTRL FOR HDMI] → [Off].
- When the camera is in Easy Mode, SYNC MENU does not appear on the TV.

[▲ Back to top](#)

Copyright 2011 Sony Corporation

[Top page](#) > [Viewing images on a TV](#) > [Viewing an image on a Standard Definition \(SD\) TV](#) > [Viewing an image on a Standard Definition \(SD\) TV](#)

Viewing an image on a Standard Definition (SD) TV

You can view images recorded on the camera in standard picture quality by connecting the camera to a Standard Definition (SD) TV using a USB/AV/DC IN Cable for multi-use terminal (sold separately). Refer also to the operating instructions supplied with the TV.

1. Turn off both the camera and the TV.
2. Connect the multi connector of the camera **(A)** and the audio/video input jacks on the TV **(B)** using a USB/AV/DC IN Cable for multi-use terminal (sold separately) **(C)**.

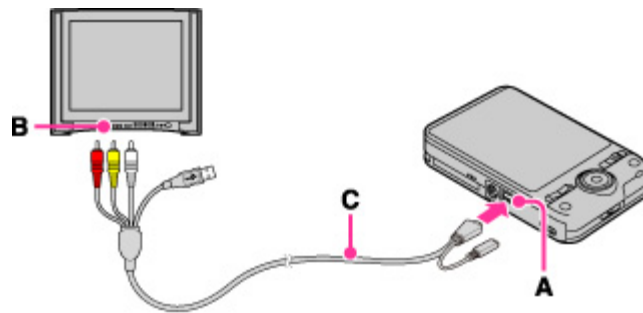

- Use a Type3b-compliant USB/AV/DC IN Cable for multi-use terminal (sold separately).
3. Turn on the TV and set the input.
 4. Press  (Playback) button to turn on the camera. Images shot with the camera appear on the TV. Select the desired image with the control wheel.

▶ Operation Search
▶ Before Use
▶ Shooting
▶ Viewing
▶ Using 3D Functions
▶ Using MENU items (Shooting)
▶ Using MENU items (Viewing)
▶ Changing settings
▶ Viewing images on a TV
▶ Using with your computer
▶ Printing
▶ Troubleshooting
▶ Precautions/About this camera

[→ Contents list](#)

[▲ Back to top](#)

Copyright 2011 Sony Corporation

[Top page](#) > [Using with your computer](#) > [Recommended computer environment](#) > [Recommended computer environment \(Windows\)](#)

Recommended computer environment (Windows)

The following computer environment is recommended when using the supplied software “PMB”, “Music Transfer” and “PMB Portable”, and when importing images via a USB connection.

OS (pre-installed)	Microsoft Windows XP* ¹ SP3/Windows Vista* ² SP2/Windows 7
Others	CPU: Intel Pentium III 800 MHz or faster (For playing/editing the High Definition movies: Intel Core Duo 1.66 GHz or faster/Intel Core 2 Duo 1.66 GHz or faster (Intel Core 2 Duo 2.26 GHz or faster is required when processing HD FX/HD FH movies)) Memory: 512 MB or more (For playing/editing the High Definition movies: 1 GB or more) Hard Disk: Disk space required for installation—approximately 500 MB Display: Screen resolution: 1,024 × 768 dots or more

*¹ 64-bit editions and Starter (Edition) are not supported.

Windows Image Mastering API (IMAPI) Ver.2.0 or later is required to use the function for creating discs.

*² Starter (Edition) is not supported.

Notes

- Operation is not assured in an environment based on an upgrade of the operating systems described above or in a multi-boot environment.
- If you connect two or more USB devices to a single computer at the same time, some devices, including the camera, may not operate, depending on the types of USB devices you are using.
- Connecting the camera using a USB interface that is compatible with Hi-Speed USB (USB 2.0) allows advanced transfer (high speed transfer), as the camera is compatible with Hi-Speed USB (USB 2.0).
- When your computer resumes activity from suspend or sleep mode, communication between the camera and your computer may not recover at the same time.

▶ Operation Search
▶ Before Use
▶ Shooting
▶ Viewing
▶ Using 3D Functions
▶ Using MENU items (Shooting)
▶ Using MENU items (Viewing)
▶ Changing settings
▶ Viewing images on a TV
▶ Using with your computer
▶ Printing
▶ Troubleshooting
▶ Precautions/About this camera

[➔ Contents list](#)

[▲ Back to top](#)

[Top page](#) > [Using with your computer](#) > [Recommended computer environment](#) > [Recommended computer environment \(Macintosh\)](#)

Recommended computer environment (Macintosh)

The following computer environment is recommended when using “Music Transfer” and “PMB Portable” and when importing images via a USB connection.

OS (pre-installed)	USB Connection: Mac OS X (v10.3 to v10.6) Music Transfer/PMB Portable: Mac OS X* (v10.4 to v10.6)
--------------------	--

* Equipped with Intel Processor

Notes

- Operation is not assured in an environment based on an upgrade of the operating systems described above or in a multi-boot environment.
- If you connect two or more USB devices to a single computer at the same time, some devices, including the camera, may not operate, depending on the types of USB devices you are using.
- Connecting the camera using a USB interface that is compatible with Hi-Speed USB (USB 2.0) allows advanced transfer (high speed transfer), as the camera is compatible with Hi-Speed USB (USB 2.0).
- When your computer resumes activity from suspend or sleep mode, communication between the camera and your computer may not recover at the same time.

▶ Operation Search
▶ Before Use
▶ Shooting
▶ Viewing
▶ Using 3D Functions
▶ Using MENU items (Shooting)
▶ Using MENU items (Viewing)
▶ Changing settings
▶ Viewing images on a TV
▶ Using with your computer
▶ Printing
▶ Troubleshooting
▶ Precautions/About this camera

[➡ Contents list](#)

[▲ Back to top](#)

▶ Operation Search
▶ Before Use
▶ Shooting
▶ Viewing
▶ Using 3D Functions
▶ Using MENU items (Shooting)
▶ Using MENU items (Viewing)
▶ Changing settings
▶ Viewing images on a TV
▶ Using with your computer
▶ Printing
▶ Troubleshooting
▶ Precautions/About this camera

[➡ Contents list](#)

“PMB (Picture Motion Browser)”

- “PMB” allows you to import images shot with the camera to a computer for display. Make a USB connection between the camera and your computer, and click [Import].
- Images on a computer can be exported to a memory card, and displayed on the camera. Make a USB connection between the camera and your computer, click [Export] → [Easy Export (PC Sync)] in the [Manipulate] menu, and click [Export].
- You can save and print images with the date.
- You can display images stored on a computer by shooting date in a calendar display.
- You can correct (Red Eye Correction, etc.) still images, and change the shooting date and time.
- Blu-ray discs, AVCHD discs and DVD-Video discs can be created from AVCHD movies imported to a computer. (An Internet connection is required when creating a Blu-ray disc or a DVD-Video disc for the first time.) However, AVCHD discs cannot be created from movies recorded in [AVC HD 24M (FX)] quality. Save [AVC HD 24M (FX)] quality movies to Blu-ray discs.
- You can upload images to a network service. (An internet connection environment is required.)
- For other details, see  (PMB Help).

[▲ Back to top](#)



- ▶ Operation Search
- ▶ Before Use
- ▶ Shooting
- ▶ Viewing
- ▶ Using 3D Functions
- ▶ Using MENU items (Shooting)
- ▶ Using MENU items (Viewing)
- ▶ Changing settings
- ▶ Viewing images on a TV
- ▶ Using with your computer
- ▶ Printing
- ▶ Troubleshooting
- ▶ Precautions/About this camera

[➡ Contents list](#)

“Music Transfer”

“Music Transfer” allows you to replace the Music files provided in the camera at the factory with your favorite tracks, and to delete and add Music files.

You can also restore the tracks stored at the factory to your camera.

- The following track types can be imported using “Music Transfer”.
 - MP3 files stored on the hard disk of your computer
 - Music CD tracks
 - Preset-music saved on the camera
- Before starting up “Music Transfer” perform MENU →  (Settings) →  (Main Settings) → [Download Music], and connect the camera to the computer.

For other details, see the help in “Music Transfer”.

Related Topic





[Download Music](#)

[Empty Music](#)

[▲ Back to top](#)

[Top page](#) > [Using with your computer](#) > [Using the software](#) > [Installing “PMB” and “Music Transfer” \(Windows\)](#)

Installing “PMB” and “Music Transfer” (Windows)

- Turn on your computer and insert the CD-ROM (supplied) into the CD-ROM drive. The installation menu screen appears.
 - If it does not appear, double-click [Computer] (in Windows XP, [My Computer]) →  (SONYPMB).
 - If the AutoPlay screen appears, select “Run Install.exe” and follow the instructions that appear on the screen to proceed with the installation.
- Click [Install].
The “Choose Setup Language” screen appears.
- Select the desired language, then proceed to the following screen.
The “License Agreement” screen appears.
- Carefully read the agreement, click the radio button (→) to accept the terms of the agreement, and then click [Next].
- Follow the instructions on the screen to complete the installation.
 - Restarting the computer may be necessary. When the restarting confirmation message appears, restart the computer following the instructions on the screen.
 - DirectX may be installed depending on the system environment of your computer.
- Connect the camera to your computer when the connecting confirmation message appears.
 - When the camera is not connected to your computer, some functions cannot be used, such as importing images.
- Remove the CD-ROM after the installation is complete.
- Start up the software.
 - To start up “PMB,” click  (PMB) on the desktop.
For the detailed operation method, see the following PMB support page (English only): <http://www.sony.co.jp/pmb-se/> or click  (PMB Help).
 - To start up “PMB” from the Start menu, select [Start] → [All Programs] →  (PMB).
 - If “PMB” was installed on your computer and if you re-install “PMB” using the supplied CD-ROM, you can start up all the applications from “PMB Launcher.” To start up “PMB Launcher,” double-click  (PMB Launcher) on the desktop.

Notes

- Log on as Administrator.
- If “PMB” has been already installed on your computer and that “PMB” version number is lower than that of the supplied CD-ROM, re-install “PMB” using the supplied CD-ROM.
- If the version number is higher than that of the supplied CD-ROM, you do not need to re-install “PMB”. When you connect the camera and the computer via USB cable, the available “PMB” function is activated.
- If “PMB” has already been installed on your computer and that “PMB” version number is lower than 5.0, some functions may become invalid after you install “PMB” using the supplied CD-ROM. Also, you can start up “PMB” or other various software from “PMB Launcher” installed at the same time. To start up “PMB Launcher” double-click  (PMB Launcher) on the desktop.

▶ Operation Search
▶ Before Use
▶ Shooting
▶ Viewing
▶ Using 3D Functions
▶ Using MENU items (Shooting)
▶ Using MENU items (Viewing)
▶ Changing settings
▶ Viewing images on a TV
▶ Using with your computer
▶ Printing
▶ Troubleshooting
▶ Precautions/About this camera

→ [Contents list](#)

[Top page](#) > [Using with your computer](#) > [Using the software](#) > [Installing “Music Transfer” \(Macintosh\)](#)

Installing “Music Transfer” (Macintosh)

1. Turn on your Macintosh computer, and insert the CD-ROM (supplied) into the CD-ROM drive.
2. Double-click  (SONYPMB).
3. Double-click the [MusicTransfer.pkg] file in the [Mac] folder.
The installation of the software starts.

Notes

- “PMB” is not compatible with Macintosh computers.
- Shut down all other application software before you install “Music Transfer”.
- For installation, you need to log on as Administrator.

[▲ Back to top](#)

▶ Operation Search
▶ Before Use
▶ Shooting
▶ Viewing
▶ Using 3D Functions
▶ Using MENU items (Shooting)
▶ Using MENU items (Viewing)
▶ Changing settings
▶ Viewing images on a TV
▶ Using with your computer
▶ Printing
▶ Troubleshooting
▶ Precautions/About this camera

[➡ Contents list](#)

Copyright 2011 Sony Corporation

[Top page](#) > [Using with your computer](#) > [Connecting the camera to the computer](#) > [Connecting the camera to the computer](#)

Connecting the camera to the computer

1. Connect the camera to your computer using a multi-use terminal USB cable (supplied) **(A)**.
 - When a USB connection is established for the first time, your computer automatically runs a program to recognize the camera. Wait for a while.

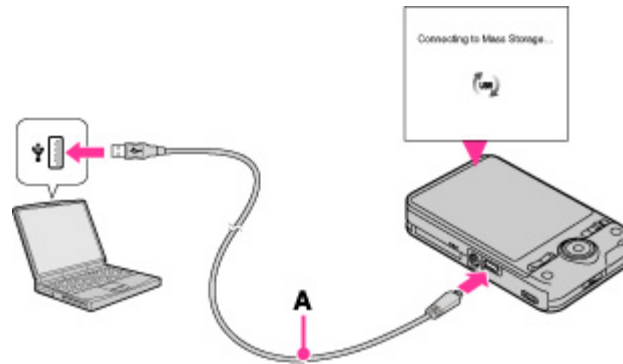

- When connecting the camera to a computer using the multi-use terminal USB cable, power feeding from the computer starts if [USB Power Supply] is set to [On]. ([On] is the default setting.)

Related Topic

[USB Connect Setting](#)

[LUN Setting](#)

[→ Contents list](#)

[▲ Back to top](#)

[Top page](#) > [Using with your computer](#) > [Connecting the camera to the computer](#) > [Importing images to a computer \(Windows\)](#)

Importing images to a computer (Windows)

“PMB” allows you to easily import images.
For details on “PMB” functions, see the “PMB Help”.

Importing images to a computer without using “PMB”

When the AutoPlay Wizard appears after making a USB connection between the camera and a computer, click [Open folder to view files] → [OK] → [DCIM] or [MP_ROOT] → copy the desired images to the computer.

Notes

- Use “PMB” for operations such as when importing AVCHD movies to a computer.
- If operations are performed on an AVCHD movie file or folder on the camera from a PC while the camera is connected to a PC, it may destroy the image file or playback may become impossible. Do not delete or copy AVCHD movies on the camera’s memory card from a PC. Sony bears no responsibility for the result of operations of this type.
- The camera creates a 3D image by combining a JPEG file with an MPO file. If you delete either file on a PC, you cannot playback the 3D image.

▶ Operation Search
▶ Before Use
▶ Shooting
▶ Viewing
▶ Using 3D Functions
▶ Using MENU items (Shooting)
▶ Using MENU items (Viewing)
▶ Changing settings
▶ Viewing images on a TV
▶ Using with your computer
▶ Printing
▶ Troubleshooting
▶ Precautions/About this camera

[➡ Contents list](#)

[▲ Back to top](#)

[Top page](#) > [Using with your computer](#) > [Connecting the camera to the computer](#) > [Importing images to a computer \(Macintosh\)](#)

Importing images to a computer (Macintosh)

1. Connect the camera to your Macintosh computer first. Double-click the newly recognized icon on the desktop → the folder where the images you want to import are stored.
2. Drag and drop the image files to the hard disk icon.
The image files are copied to the hard disk.
3. Double-click the hard disk icon → the desired image file in the folder containing the copied files.
The image is displayed.

Notes

- If operations are performed on an AVCHD movie file or folder on the camera from a PC while the camera is connected to a PC, it may destroy the image file or playback may become impossible. Do not delete or copy AVCHD movies on the camera's memory card from a PC. Sony bears no responsibility for the result of operations of this type.
- The camera creates a 3D image by combining a JPEG file with an MPO file. If you delete either file on a PC, you cannot playback the 3D image.

▶ Operation Search
▶ Before Use
▶ Shooting
▶ Viewing
▶ Using 3D Functions
▶ Using MENU items (Shooting)
▶ Using MENU items (Viewing)
▶ Changing settings
▶ Viewing images on a TV
▶ Using with your computer
▶ Printing
▶ Troubleshooting
▶ Precautions/About this camera

[→ Contents list](#)

[▲ Back to top](#)

Copyright 2011 Sony Corporation

[Top page](#) > [Using with your computer](#) > [Connecting the camera to the computer](#) > [Deleting the USB connection](#)

Deleting the USB connection

Perform the procedures from step 1 to 3 below before:

- Disconnecting the cable.
- Removing a memory card.
- Inserting a memory card into the camera after copying images from the internal memory.
- Turning off the camera.

1. Double-click the disconnect icon () on the tasktray.

Windows Vista



Windows XP



2. Click  (USB Mass Storage Device) → [Stop].
3. Confirm the device on the confirmation window, then click [OK].

Note

- Drag and drop the icon of the memory card or the drive icon to the “Trash” icon beforehand when you use a Macintosh computer, and the camera is disconnected from the computer.
- The disconnect icon may not appear when you use a Windows 7 computer. In this case, you can disconnect the camera from the computer without following the above steps.

▶ Operation Search
▶ Before Use
▶ Shooting
▶ Viewing
▶ Using 3D Functions
▶ Using MENU items (Shooting)
▶ Using MENU items (Viewing)
▶ Changing settings
▶ Viewing images on a TV
▶ Using with your computer
▶ Printing
▶ Troubleshooting
▶ Precautions/About this camera

[➡ Contents list](#)

[▲ Back to top](#)

▶ Operation Search
▶ Before Use
▶ Shooting
▶ Viewing
▶ Using 3D Functions
▶ Using MENU items (Shooting)
▶ Using MENU items (Viewing)
▶ Changing settings
▶ Viewing images on a TV
▶ Using with your computer
▶ Printing
▶ Troubleshooting
▶ Precautions/About this camera

[➡ Contents list](#)

"PMB Portable"

This camera has a built-in application "PMB Portable".

You can use this application to do the following:

- You can easily upload images to a blog or other media service.
- You can upload images from a computer connected to the Internet even when you are away from home or the office.
- You can easily register the media services (such as blogs) you use frequently.

For details on "PMB Portable", see the "PMB Portable" help.

Notes on "PMB Portable"

"PMB Portable" makes it possible to download the URLs of a number of websites from the server administered by Sony (the "Sony server").

In order to use "PMB Portable" to enjoy the benefits of the image uploading service or other services (the "services") provided by these and other websites, you must consent to the following.

- Some websites require registration procedures and/or fees to use their services. In using such services, you must comply with the terms and conditions established by the websites concerned.
- Services may be terminated or changed in accordance with the convenience of the website operators. Sony will not be held responsible for any trouble occurring between the users and third parties or any inconvenience caused to users relating to the utilization of the services inclusive of the termination of or changes to such services.
- To view a website, you will be redirected to it by the Sony server. There may be times when you cannot access the website because of server maintenance or for other reasons.
- If the operation of the Sony server is to be terminated, you will be notified of the termination ahead of time on Sony's website, etc.
- The URLs to which you are redirected by the Sony server and other information may be recorded for the purposes of improving Sony's future products and services. However, no personal data will be recorded on such occasions.

[▲ Back to top](#)

[Top page](#) > [Using with your computer](#) > [Uploading images to a media service](#) > [Starting up “PMB Portable” \(Windows\)](#)

Starting up “PMB Portable” (Windows)

For Windows, when using “PMB Portable” for the first time, you must select the language. Follow the procedure below to make the selection. Once the language selection has been made, steps 3 to 5 are unnecessary the next time you use “PMB Portable”.

1. Connect the camera to a computer.
Windows 7: Activate Device Stage*.
Windows XP/Windows Vista: The AutoPlay Wizard appears.
* Device Stage is a menu screen to manage connected devices, such as a camera. (Function of Windows 7)
2. Click [PMB Portable].
The User Agreement screen appears.
3. Select the desired language, then click [OK].
The Region Selection screen appears.
4. Select the appropriate [Region] and [Country/Area], and then click [OK].
The User Agreement screen appears.
5. Read the agreement carefully. If you accept the terms of the agreement, click [I Agree].
“PMB Portable” starts up.

Notes

- “PMB Portable” is not supported for AVCHD movies.
- Set [LUN Setting] in [Main Settings] to [Multi].
- If you cannot start up “PMB Portable”, set [USB Connect Setting] to [Mass Storage].
- Always connect to a network when using “PMB Portable”.
- When uploading images over the Internet, the cache may remain in the computer being used depending on the service provider. This is also true when this camera is used for this purpose.
- When a bug occurs in “PMB Portable” or you delete “PMB Portable” by mistake, you can repair “PMB Portable” by downloading the PMB Portable installer from the website.
- If the Auto Play Wizard does not appear with Windows XP/Windows Vista, click [Computer] (in Windows XP, [My Computer]) → [PMBPORTABLE], and double-click [PMBP_Win.exe].
- If Device Stage does not activate with Windows 7, click [Computer] and double-click camera icon → media icon → [APPLICATION] → [PMBP_MTP.exe].
- The initial screen for Device Stage that does not contain specific information about the model may appear, depending on the settings of your computer when using Windows 7. If this happens, download the latest information following the instructions on the screen.
- When using Windows 7, the screen automatically switches to Mass Storage connection when starting up “PMB Portable”.

[▲ Back to top](#)

Copyright 2011 Sony Corporation

▶ Operation Search
▶ Before Use
▶ Shooting
▶ Viewing
▶ Using 3D Functions
▶ Using MENU items (Shooting)
▶ Using MENU items (Viewing)
▶ Changing settings
▶ Viewing images on a TV
▶ Using with your computer
▶ Printing
▶ Troubleshooting
▶ Precautions/About this camera

[➡ Contents list](#)

[Top page](#) > [Using with your computer](#) > [Uploading images to a media service](#) > [Starting up “PMB Portable” \(Macintosh\)](#)

Starting up “PMB Portable” (Macintosh)

1. Make a USB connection between the camera and a Macintosh computer.
When you connect the camera and your computer, [PMBPORTABLE] appears on the desktop.
Click [×] to close any unnecessary drives.
2. Click [PMBP_Mac] in the [PMBPORTABLE] folder.
The Region Selection screen appears.
3. Select the appropriate [Region] and [Country/Area], and then click [OK].
The User Agreement screen appears.
4. Read the agreement carefully. If you accept the terms of the agreement, click [I Agree].
“PMB Portable” starts up.

Notes

- “PMB Portable” is not supported for AVCHD movies.
- Set [LUN Setting] in [Main Settings] to [Multi].
- If you cannot start up “PMB Portable”, set [USB Connect Setting] to [Mass Storage].
- Always connect to a network when using “PMB Portable”.
- When uploading images over the Internet, the cache may remain in the computer being used depending on the service provider. This is also true when this camera is used for this purpose.
- When a bug occurs in “PMB Portable” or you delete “PMB Portable” by mistake, you can repair “PMB Portable” by downloading the PMB Portable installer from the website.

▶ Operation Search
▶ Before Use
▶ Shooting
▶ Viewing
▶ Using 3D Functions
▶ Using MENU items (Shooting)
▶ Using MENU items (Viewing)
▶ Changing settings
▶ Viewing images on a TV
▶ Using with your computer
▶ Printing
▶ Troubleshooting
▶ Precautions/About this camera

[➡ Contents list](#)

[▲ Back to top](#)

- ▶ Operation Search
- ▶ Before Use
- ▶ Shooting
- ▶ Viewing
- ▶ Using 3D Functions
- ▶ Using MENU items (Shooting)
- ▶ Using MENU items (Viewing)
- ▶ Changing settings
- ▶ Viewing images on a TV
- ▶ Using with your computer
- ▶ Printing
- ▶ Troubleshooting
- ▶ Precautions/About this camera

➔ [Contents list](#)



Selecting the method for creating a disc of movies

▼ Characteristics of each type of disc

You can create a disc from AVCHD movies that have been recorded with this camera. Select the method that suits your disc player.

For details on the method for creating a disc using “PMB”, see “PMB Help.”

To import movies into a PC, see [\[Details\]](#) (Windows)/[\[Details\]](#) (Macintosh).

Player	Creation method	Disc type
Blu-ray disc playback devices (Blu-ray disc player, PlayStation®3, etc.)	Importing movies to a computer using “PMB” and creating a Blu-ray disc	
AVCHD format playback devices (Sony Blu-ray disc player, PlayStation®3, etc.)	Importing movies to a computer using “PMB” and creating an AVCHD format disc	
	Creating an AVCHD format disc using a DVD Writer/Recorder other than DVDirect Express	
Ordinary DVD playback devices (DVD player, computer that can play DVDs, etc.)	Importing movies to a computer using “PMB” and creating a standard definition image quality (STD) disc	



Notes

- If you create a disc using Sony DVDirect (DVD Writer), use the memory card slot of the DVD Writer or connect the DVD Writer via USB connection to transfer the data.
- If you use Sony DVDirect (DVD Writer), check that the firmware is updated to the newest version.

For details, see the following URL:

<http://sony.storagesupport.com/>

Characteristics of each type of disc

	Using a Blu-ray disc enables you to record high-definition image quality (HD) movies of a longer duration than DVD discs.
	High-definition image quality (HD) movies can be recorded on DVD media, such as DVD-R discs, and a high-definition image quality (HD) disc is created. <ul style="list-style-type: none"> ● You can play a high-definition image quality (HD) disc on AVCHD format playback devices, such as a Sony Blu-ray disc player and a PlayStation®3. You cannot play the disc on ordinary DVD players.
	Standard definition image quality (STD) movies converted from high-definition image quality (HD) movies can be recorded on DVD media, such as DVD-R discs, and a standard definition image quality (STD) disc is created.

Types of discs that can be used with “PMB”

The following 12-cm discs can be used with “PMB”. For information on Blu-ray discs, see [\[Details\]](#).

DVD-R / DVD+R / DVD+R DL: Cannot be re-written.

DVD-RW / DVD+RW: Can be re-written and used again.

- Always maintain your PlayStation®3 to use the latest version of the PlayStation®3 system software.
- The PlayStation®3 may not be available in some countries/regions.

[▲ Back to top](#)

Copyright 2011 Sony Corporation

▶ Operation Search
▶ Before Use
▶ Shooting
▶ Viewing
▶ Using 3D Functions
▶ Using MENU items (Shooting)
▶ Using MENU items (Viewing)
▶ Changing settings
▶ Viewing images on a TV
▶ Using with your computer
▶ Printing
▶ Troubleshooting
▶ Precautions/About this camera

[➡ Contents list](#)

Creating AVCHD discs

An AVCHD disc with HD picture quality can be created from AVCHD movies imported to a PC using supplied “PMB” software.

1. Turn on the power of the PC and insert an unused disc in the DVD drive.
2. Start “PMB”.
3. Select the AVCHD movie to be written to the disc.
4. Click  (Create Discs), then select [Create AVCHD Format Discs (HD)].
5. Create the disc by following the on-screen instructions.

Playing an AVCHD disc on a PC

AVCHD discs can be played on a PC using “Player for AVCHD” installed along with “PMB”. To start the software, click on [Start] → [All Programs] → [PMB] → [PMB Launcher] → [View] → [Player for AVCHD].

For detailed operations, see the Help for “Player for AVCHD”.

- Images may not play back smoothly depending on the PC environment.

Notes

- Be sure that “PMB” has already been installed. [\[Details\]](#)
- You cannot record the following images on an AVCHD disc:
 - Still images
 - MP4 movies
 - Movies recorded in [AVC HD 24M (FX)] quality
- Disc creation may take time.

[▲ Back to top](#)

[Top page](#) > [Using with your computer](#) > [Creating a disc of movies](#) > [Creating standard definition image quality \(STD\) discs](#)

Creating standard definition image quality (STD) discs

DVD discs with standard definition image quality (STD) can be created using supplied “PMB” software and selecting an AVCHD movie imported to the PC.

1. Turn on the power of the PC and insert an unused disc in the DVD drive.
 - If software other than “PMB” starts automatically, exit that software.
2. Start “PMB”.
3. Select the AVCHD movie to be written to the disc.
4. Click  (Create Discs), then select [Create DVD-Video Format Discs (STD)].
5. Create the disc by following the on-screen instructions.

Notes

- Be sure that “PMB” has already been installed. [\[Details\]](#)
- Discs cannot be created for MP4 movies.
- Disc creation may take time due to converting the AVCHD movie to standard definition image quality (STD).
- The PC must be connected to the Internet the first time a DVD-Video disc is created.

▶ Operation Search
▶ Before Use
▶ Shooting
▶ Viewing
▶ Using 3D Functions
▶ Using MENU items (Shooting)
▶ Using MENU items (Viewing)
▶ Changing settings
▶ Viewing images on a TV
▶ Using with your computer
▶ Printing
▶ Troubleshooting
▶ Precautions/About this camera

[➡ Contents list](#)

[▲ Back to top](#)

[Top page](#) > [Using with your computer](#) > [Creating a disc of movies](#) > [Creating Blu-ray discs](#)

Creating Blu-ray discs

You can create Blu-ray discs from AVCHD movies imported to a PC. The PC in question must be capable of creating Blu-ray discs. BD-R (not re-writable) or BD-RE (re-writable) discs can be used. Multi-session recordings cannot be made. To create Blu-ray discs, be sure to install [BD Add-on Software] on the "PMB" installation screen. To install, your PC must be connected to the Internet. For detailed operations, see "PMB Help".

[▲ Back to top](#)

- ▶ Operation Search
- ▶ Before Use
- ▶ Shooting
- ▶ Viewing
- ▶ Using 3D Functions
- ▶ Using MENU items (Shooting)
- ▶ Using MENU items (Viewing)
- ▶ Changing settings
- ▶ Viewing images on a TV
- ▶ Using with your computer
- ▶ Printing
- ▶ Troubleshooting
- ▶ Precautions/About this camera

[➡ Contents list](#)

Copyright 2011 Sony Corporation

▶ Operation Search
▶ Before Use
▶ Shooting
▶ Viewing
▶ Using 3D Functions
▶ Using MENU items (Shooting)
▶ Using MENU items (Viewing)
▶ Changing settings
▶ Viewing images on a TV
▶ Using with your computer
▶ Printing
▶ Troubleshooting
▶ Precautions/About this camera

[➡ Contents list](#)

Printing still images

You can print still images using the following methods.

- Printing directly using a printer which supports your memory card type.
For details, see the operating instructions supplied with the printer.
- Printing using a computer
You can import images to a computer using the supplied “PMB” software and print the images.
For details, see the “PMB Help”.
- Printing at a shop [\[Details\]](#)

Notes

- When you print still images shot in [16:9] mode, both edges may be cut off.
- You cannot print panorama images depending on the printer.

[▲ Back to top](#)

▶ Operation Search
▶ Before Use
▶ Shooting
▶ Viewing
▶ Using 3D Functions
▶ Using MENU items (Shooting)
▶ Using MENU items (Viewing)
▶ Changing settings
▶ Viewing images on a TV
▶ Using with your computer
▶ Printing
▶ Troubleshooting
▶ Precautions/About this camera

[➡ Contents list](#)

Printing at a shop

You can take a memory card containing images shot with the camera to a photo printing service shop. As long as the shop supports photo printing services conforming to DPOF, you can make a **DPOF** (Print order) mark on images in advance in the playback mode so that you do not have to reselect them when you print them out at the shop.

Notes

- You cannot print images stored in the internal memory at a print shop directly from the camera. Copy the images to a memory card, then take the memory card to the print shop. [\[Details\]](#)
- Consult your photo printing service shop as to what types of memory card they handle.
- A memory card adaptor (sold separately) may be necessary. Consult your photo printing service shop.
- Before you take image data to a shop, always copy (back up) your data to a disk.
- You cannot set the number of prints.

Related Topic

[Print \(DPOF\)](#)[▲ Back to top](#)

▶ Operation Search
▶ Before Use
▶ Shooting
▶ Viewing
▶ Using 3D Functions
▶ Using MENU items (Shooting)
▶ Using MENU items (Viewing)
▶ Changing settings
▶ Viewing images on a TV
▶ Using with your computer
▶ Printing
▶ Troubleshooting
▶ Precautions/About this camera

[➡ Contents list](#)

If you have problems

If you experience trouble with the camera, try the following solutions.

1. Check the items under “Troubleshooting”, then check your camera.
If a code such as “C/E: □ □ : □ □ ” appears on the screen, see “Self-diagnosis display”.
2. Remove the battery pack, wait for about one minute, re-insert the battery pack, then turn on the power.
3. Initialize the settings. [\[Details\]](#)
4. Consult your Sony dealer or local authorized Sony service facility.
 - Be aware that by sending the camera for repair, you give consent that the contents of the internal memory, music files may be checked.
 - Additional information on this product and answers to frequently asked questions can be found at our Customer Support Website.
<http://www.sony.net/>

[▲ Back to top](#)

▶ Operation Search
▶ Before Use
▶ Shooting
▶ Viewing
▶ Using 3D Functions
▶ Using MENU items (Shooting)
▶ Using MENU items (Viewing)
▶ Changing settings
▶ Viewing images on a TV
▶ Using with your computer
▶ Printing
▶ Troubleshooting
▶ Precautions/About this camera

[→ Contents list](#)

Battery pack and power

Cannot insert the battery pack into the camera.

- Make sure the direction of the battery pack is correct, and insert it until the battery eject lever is locked.

Cannot turn on the camera.

- After inserting the battery pack into the camera, it may take a few moments for the camera to power up.
- Make sure that the battery pack is inserted correctly.
- The battery pack is discharged. Charge the battery pack.
- The battery pack terminals are dirty. Gently wipe away any dirt with a soft cloth.
- Check that the battery pack type is NP-BN1.

The power turns off suddenly.

- Depending on the camera and battery temperature, the power may turn off automatically to protect the camera. In this case, a message is displayed on the LCD screen before the power turns off.
- If you do not operate the camera for a certain period of time while the power is on and [Power Save] is set to [Standard] or [Stamina], the camera turns off automatically to prevent wearing down the battery pack. Turn on the camera again.

The remaining charge indicator is incorrect.

- This is caused when you use the camera in an extremely hot or cold location.
- A discrepancy arose between the remaining charge indicator and the actual remaining battery charge. Fully discharge the battery pack once, then charge it to correct the indication. The remaining charge indicator may not be correct under certain circumstances.
- Battery capacity decreases over time and through repeated use. If decreased usage time between charges becomes significant, it is probably time to replace it with a new one.

The Power/charge lamp of the camera flashes while charging the battery.

- Check that the battery pack type is NP-BN1.
- The Power/charge lamp of the camera flashes infrequently when you use a battery pack that has not been used for a long time. In such cases, remove the battery pack from the camera and re-insert it.
- For details, see [“Battery pack” \[Details\]](#).

The battery is not charged even if the Power/charge lamp turns off and charging

is finished.

- This happens when you charge the battery pack in an extremely hot or cold location. Charge the battery pack within the proper charging temperature range of between 10°C to 30°C (50°F to 86°F).

[▲ Back to top](#)

Copyright 2011 Sony Corporation

▶ Operation Search
▶ Before Use
▶ Shooting
▶ Viewing
▶ Using 3D Functions
▶ Using MENU items (Shooting)
▶ Using MENU items (Viewing)
▶ Changing settings
▶ Viewing images on a TV
▶ Using with your computer
▶ Printing
▶ Troubleshooting
▶ Precautions/About this camera

[→ Contents list](#)

Shooting still images/movies

Cannot record images.

- If images are recorded on the internal memory even when a memory card is inserted into the camera, make sure that the memory card is fully inserted into the camera.
- Check the free capacity of the internal memory or memory card. If it is full, do one of the following:
 - Delete unnecessary images. [\[Details\]](#) [\[Details\]](#)
 - Change the memory card.
- You cannot record images while charging the flash.
- When recording movies, it is recommended that you use the following memory cards:
 - “Memory Stick PRO Duo” (Mark2) media, “Memory Stick PRO-HG Duo” media
 - SD memory card, SDHC memory card or SDXC memory card (Class 4 or faster)
- Set [Demo Mode] to [Off]. [\[Details\]](#)

Smile Shutter function does not work.

- No image is shot if a smiling face is not detected. [\[Details\]](#)
- Set [Demo Mode] to [Off]. [\[Details\]](#)



Anti-blur function does not work.

- The anti-blur function may not work properly when shooting night scenes.
- Shoot after pressing the shutter button halfway down.

Recording takes a long time.

- When the shutter speed becomes slower than a certain speed, for example, when you shoot images in dark locations, the camera automatically reduces the image noise. This function is called NR (noise reduction) slow shutter and the shooting time takes longer.

The image is out of focus.

- The subject is too close. When shooting, make sure to position the lens farther away from the subject than the shortest shooting distance (approximately 5 cm (2 inches) (W)/1 m (3 ft 3 3/8 inches) (T) from the lens).
-  (Twilight),  (Landscape) or  (Fireworks) mode is selected in the Scene Selection when shooting still images.

Zoom does not work.











- You cannot use the optical zoom in Intelligent Sweep Panorama mode and 3D shooting mode.

- You cannot use the Smart zoom depending on the image size. [\[Details\]](#)
- You cannot use the digital zoom when:
 - In Superior Auto mode
 - In Background Defocus mode
 - + (Backlight Correction HDR) mode is selected in the Scene Selection
 - The Smile Shutter is working.
 - [Self-Timer] is set to [Self-portrait One Person] or [Self-portrait Two People].

Cannot select the Face Detection function.

- You can select Face Detection only when the focus mode is set to [Multi AF] and the metering mode is set to [Multi].



The flash does not work.

- You cannot use the flash when:
 - Shooting in Background Defocus mode
 - Burst mode is selected. [\[Details\]](#)
 -  (Anti Motion Blur) mode,  (Twilight) mode,  (Hand-held Twilight) mode,  (High Sensitivity) mode or  (Fireworks) mode is selected in Scene Selection.
 - Shooting in Sweep Panorama mode.
 - Shooting in 3D mode
 - Shooting in movie mode.
- Set the flash to [On] when the Scene Selection mode is set to  (Landscape),  (Gourmet),  (Pet),  (Beach) or  (Snow) mode. [\[Details\]](#)

Fuzzy white circular spots appear in images shot using the flash.

- Particles (dust, pollen, etc.) in the air reflected the flash light and appeared in the image. This is not a malfunction. [\[Details\]](#)

The close-up shoot function (Macro) does not work.

- The camera automatically adjusts the focus. Press and hold the shutter button halfway down. Focus adjustment may take some time when shooting a close subject.
-  (Landscape),  (Twilight) or  (Fireworks) mode is selected in the Scene Selection.

The date and time are not displayed on the LCD screen.

- While shooting, the date and time are not displayed. They are displayed only during playback.

The F value and shutter speed flash when you press and hold the shutter button halfway down.

- The exposure is incorrect. Correct the exposure. [\[Details\]](#)

The image colors are not correct.

- Adjust the White Balance. [\[Details\]](#)

Noise appears in the image when you view the screen in a dark place.

- The camera is attempting to increase the visibility of the screen by temporarily brightening the image under conditions of low illumination. There is no effect on the recorded image.

You can see a dark shadow on the image.

- Depending on the brightness of the subject, you may see a dark shadow when you change the aperture. This is not a malfunction.

The eyes of the subject come out red.

- Set [Red Eye Reduction] to [Auto] or [On]. [\[Details\]](#)
- Shoot the subject at a distance closer than the flash range using the flash.
- Light the room and shoot the subject.
- Retouch the image using [Retouch] → [Red Eye Correction] in viewing menu [\[Details\]](#), or correct using “PMB”.

Dots appear and remain on the screen.

- This is not a malfunction. These dots are not recorded.

Cannot shoot images in succession.

- The internal memory or memory card is full. Delete unnecessary images. [\[Details\]](#) [\[Details\]](#)
- The battery level is low. Insert a charged battery pack.

The same image is shot several times.

- Set [Burst Settings] to [Single]. [\[Details\]](#)
- [Scene Recognition] is set to [Advanced]. [\[Details\]](#)

[▲ Back to top](#)

▶ Operation Search
▶ Before Use
▶ Shooting
▶ Viewing
▶ Using 3D Functions
▶ Using MENU items (Shooting)
▶ Using MENU items (Viewing)
▶ Changing settings
▶ Viewing images on a TV
▶ Using with your computer
▶ Printing
▶ Troubleshooting
▶ Precautions/About this camera

[→ Contents list](#)

Viewing images

Cannot play back images.

- Make sure that the memory card is fully inserted into the camera.
- The folder/file name has been changed on your computer.
- No guarantees are made for playing back, on this camera, files containing images which were processed on a computer or images which were shot using other cameras.
- The camera is in USB mode. Delete the USB connection. [\[Details\]](#)
- Use “PMB” to play images stored on a PC with this camera.

Cannot play back stereoscopic images on the camera.

- Stereoscopic images can be played back on this camera only when that image has been recorded using [Sweep Multi Angle] mode.
- 3D images consist of a JPEG file and an MPO file. If either file is deleted on the PC, the camera may not operate correctly.

The date and time are not displayed.

- The screen display is set to display images only. Press **DISP** (Display Setting) on the control wheel to display information. [\[Details\]](#)

Cannot hear music during slideshow.

- Slideshow is played back with [Continuous Playback]. Select [Slideshow with music] and play back.
- Transfer music files to the camera with “Music Transfer”. [\[Details\]](#)
- Confirm that the volume setting and slideshow setting are correct. [\[Details\]](#)

The image does not appear on the TV.

- For viewing movies, the camera and television must use the same color television system. [\[Details\]](#)
- Check whether the connection is correct. [\[Details\]](#)

The 3D images do not appear on the TV even though the camera is in [3D Viewing] mode.

- Check that the TV is set to display the 3D images.

- ▶ Operation Search
- ▶ Before Use
- ▶ Shooting
- ▶ Viewing
- ▶ Using 3D Functions
- ▶ Using MENU items (Shooting)
- ▶ Using MENU items (Viewing)
- ▶ Changing settings
- ▶ Viewing images on a TV
- ▶ Using with your computer
- ▶ Printing
- ▶ **Troubleshooting**
- ▶ Precautions/About this camera

[➡ Contents list](#)

Deleting

Cannot delete an image.

- Cancel the protection. [\[Details\]](#)

[▲ Back to top](#)

▶ Operation Search
▶ Before Use
▶ Shooting
▶ Viewing
▶ Using 3D Functions
▶ Using MENU items (Shooting)
▶ Using MENU items (Viewing)
▶ Changing settings
▶ Viewing images on a TV
▶ Using with your computer
▶ Printing
▶ Troubleshooting
▶ Precautions/About this camera

[→ Contents list](#)

Computers

“Memory Stick PRO Duo” media is not recognized by a computer with a “Memory Stick” media slot.

- Check that the computer and the “Memory Stick” media Reader/Writer support “Memory Stick PRO Duo” media. Users of computers and “Memory Stick” media Readers/Writers made by manufacturers other than Sony should contact those manufacturers.
- If “Memory Stick PRO Duo” media is not supported, connect the camera to the computer. The computer recognizes the “Memory Stick PRO Duo” media. [\[Details\]](#)

Your computer does not recognize the camera.

- Use the multi-use terminal USB cable (supplied).
- Disconnect the USB cable from both the computer and the camera, and connect it again firmly.
- Disconnect all equipment other than the camera, the keyboard and the mouse from the USB connectors of your computer.
- Connect the camera directly to your computer without passing through a USB hub or other device.
- Set [USB Power Supply] to [Off]. Your computer may recognize the camera.

Cannot import images.

- Connect the camera and your computer correctly making a USB connection. [\[Details\]](#)
- When you shoot images with a memory card formatted by a computer, you may not be able to import the images to a computer. Shoot using a memory card formatted by the camera. [\[Details\]](#)

After making a USB connection, “PMB” does not start automatically.

- Make the USB connection after the computer is turned on.

After making a USB connection, “PMB Portable” does not start.

- Set [LUN Setting] to [Multi]. [\[Details\]](#)
- Set [USB Connect Setting] to [Auto]. If “PMB Portable” still does not start, set [USB Connect Setting] to [Mass Storage]. [\[Details\]](#)
- Connect the computer to the network.

Cannot play back images on your computer.

- If you are using “PMB”, refer to “PMB Help”. [\[Details\]](#)
-

- Consult the computer or software manufacturer.

The image and sound are interrupted by noise when you view a movie on a computer.

- You are playing back the movie directly from the memory card. Import the movie to your computer using “PMB” and play it back. [\[Details\]](#)

Images once exported to a computer cannot be viewed on the camera.

- Export them to a folder recognized by the camera, such as “101MSDCF”.
- Register the image in the Image Database File and play in [Date View]. [\[Details\]](#)

[▲ Back to top](#)

Copyright 2011 Sony Corporation

▶ Operation Search
▶ Before Use
▶ Shooting
▶ Viewing
▶ Using 3D Functions
▶ Using MENU items (Shooting)
▶ Using MENU items (Viewing)
▶ Changing settings
▶ Viewing images on a TV
▶ Using with your computer
▶ Printing
▶ Troubleshooting
▶ Precautions/About this camera

[➡ Contents list](#)

Memory card

Cannot insert a memory card.

- Insert the memory card in the correct direction.

You have formatted a memory card by mistake.

- All the data on the memory card is deleted by formatting. You cannot restore it.

Images are recorded on the internal memory even when a memory card is inserted into the camera.

- Make sure that the memory card is fully inserted into the camera.

[▲ Back to top](#)

▶ Operation Search
▶ Before Use
▶ Shooting
▶ Viewing
▶ Using 3D Functions
▶ Using MENU items (Shooting)
▶ Using MENU items (Viewing)
▶ Changing settings
▶ Viewing images on a TV
▶ Using with your computer
▶ Printing
▶ Troubleshooting
▶ Precautions/About this camera

[➡ Contents list](#)

Internal memory

Cannot play back or record images using the internal memory.

- There is a memory card inserted in the camera. Remove it.

Cannot copy the data stored in the internal memory to a memory card.

- The memory card is full. Copy to a memory card with sufficient capacity.

Cannot copy the data on the memory card or the computer to the internal memory.

- This feature is not available.

[▲ Back to top](#)

▶ Operation Search
▶ Before Use
▶ Shooting
▶ Viewing
▶ Using 3D Functions
▶ Using MENU items (Shooting)
▶ Using MENU items (Viewing)
▶ Changing settings
▶ Viewing images on a TV
▶ Using with your computer
▶ Printing
▶ Troubleshooting
▶ Precautions/About this camera

[➡ Contents list](#)

Printing

Cannot print an image.

- Refer to the operation manual of the printer.

Images are printed with both edges cut off.

- Depending on your printer, all the edges of the image may be cut off. Especially when you print an image shot with the image size set to [16:9], the lateral end of the image may be cut off.
- When printing images using your printer, cancel the trimming or borderless settings. Consult the printer manufacturer as to whether the printer provides these functions or not.
- When having images printed at a digital print shop, ask the shop whether they can print the images without cutting off both edges.

Cannot print images with the date.

- Select MENU →  (Shooting Settings) → [Write Date] → [On] to insert a date on the image. Make sure that once the date is inserted, you cannot remove that date from the image.
- Using "PMB", you can insert the date on still images that have been recorded without a date. [\[Details\]](#)

Cannot print the 3D images as they are displayed on the camera's LCD screen.

- The 3D images displayed on the camera are MPO files, but the images to be printed are JPEG files, so in some cases, the images to be printed out are not the same as the ones displayed on the LCD screen.

[▲ Back to top](#)

▶ Operation Search
▶ Before Use
▶ Shooting
▶ Viewing
▶ Using 3D Functions
▶ Using MENU items (Shooting)
▶ Using MENU items (Viewing)
▶ Changing settings
▶ Viewing images on a TV
▶ Using with your computer
▶ Printing
▶ Troubleshooting
▶ Precautions/About this camera

[➡ Contents list](#)

Others

The lens gets fogged.

- Moisture condensation has occurred. Turn off the camera and leave it for about an hour before using it.

The camera turns off with the lens portion extended.

- The battery pack is discharged. Replace it with a charged battery pack, then turn the camera on again.
- Do not attempt to force the lens that has stopped moving.

The camera becomes warm when you use it for a long time.

- This is not a malfunction.

The Clock Set screen appears when you turn on the camera.

- Set the date and time again. [\[Details\]](#)
- The internal rechargeable backup battery has discharged. Insert a charged battery, and set aside for 24 hours or more with the power left off.

The date or time is incorrect.

- The Area Setting is set to a different location than your current location. Change the setting by MENU →  (Settings) → [Clock Settings] → [Area Setting].

[▲ Back to top](#)

▶ Operation Search
▶ Before Use
▶ Shooting
▶ Viewing
▶ Using 3D Functions
▶ Using MENU items (Shooting)
▶ Using MENU items (Viewing)
▶ Changing settings
▶ Viewing images on a TV
▶ Using with your computer
▶ Printing
▶ Troubleshooting
▶ Precautions/About this camera

[→ Contents list](#)

Self-diagnosis display

If a code starting with a letter of the alphabet appears, the self-diagnosis function on the camera is working. The last two digits (indicated by) will differ depending on the state of the camera.

If you cannot solve the problem even after trying the following corrective actions a few times, the camera may need repair.

Contact your Sony dealer or local authorized Sony service facility.

C:32:

- There is trouble with the camera's hardware. Turn the power off and on again.

C:13:

- The camera cannot read or write data on the memory card. Try turning off and on the camera again, or taking out and inserting the memory card several times.
- The internal memory has experienced a format error, or an unformatted memory card is inserted. Format the internal memory or the memory card. [\[Details\]](#)
- The inserted memory card cannot be used with the camera, or the data is damaged. Insert a new memory card.

E:61:

E:62:

E:91:

- A camera malfunction has occurred. Initialize the camera, then turn the power on again. [\[Details\]](#)

E:94:

- There is a malfunction when writing or deleting data. Repair is required. Contact your Sony dealer or local authorized Sony service facility. Be prepared to give all numbers in the error code beginning from the E.

[▲ Back to top](#)

▶ Operation Search
▶ Before Use
▶ Shooting
▶ Viewing
▶ Using 3D Functions
▶ Using MENU items (Shooting)
▶ Using MENU items (Viewing)
▶ Changing settings
▶ Viewing images on a TV
▶ Using with your computer
▶ Printing
▶ Troubleshooting
▶ Precautions/About this camera

[→ Contents list](#)

Messages

If the following messages appear, follow the instructions.



- The battery level is low. Charge the battery pack immediately. Depending on the conditions of use or the type of battery pack, the indicator may flash even though there are still 5 minutes to 10 minutes of remaining battery time left.

For use with compatible battery only

- The battery inserted is not an NP-BN1 (supplied) battery pack.

Camera overheating Allow it to cool

- The camera temperature has risen. The power may turn off automatically, or you may be unable to record movies. Leave the camera in a cool location until the temperature goes down.

Internal memory error

- Turn the power off and then on again.

Reinsert the memory card.

- The inserted memory card cannot be used in the camera. [\[Details\]](#)
- The terminal section of the memory card is dirty.
- The memory card is damaged.

This memory card is not formatted correctly.

- The inserted memory card cannot be used in the camera. [\[Details\]](#)

This memory card may not be able to record or play images correctly.

- The inserted memory card cannot be used in the camera. [\[Details\]](#)

Buffer overflow. Writing to the media was not completed in time.

- If you use a memory card that has been recorded and erased repeatedly, or that was formatted on a different camera, the data writing speed may be too slow. First back up any data on the card to a computer, and then reformat the card before using it. [\[Details\]](#)
- The writing speed of the memory card you are using is not sufficient for movie recordings. Use a “Memory Stick PRO-HG Duo” media, “Memory Stick PRO Duo” (Mark2) media, or an

SD card (Class 4 or faster).

The memory card is locked. Check the tab.

- You are using the memory card with the write-protect switch, and the switch is set to the LOCK position. Set the switch to the recording position.
-

This is a read- only memory card.

- The camera cannot record or delete images on this memory card.
-

Writing to the memory card was not completed correctly Recover data

- Reinsert the memory card, and follow the instructions on the screen.
-

No images

- No images that can be played back have been recorded in the internal memory.
 - No images that can be played back have been recorded in this folder of the memory card.
-

No still images

- There are no 3D images that can be played back in [3D Viewing] mode.
 - The selected folder or date does not contain a file that can be played back in a slideshow.
-

File found which was not recognized

- You tried to delete a folder containing a file that cannot be played on this camera. Delete the file on a computer and then delete the folder.
-

Folder error. Cannot record to the selected folder. Please select a different folder.

- A folder with the same first three digit number already exists on the memory card (for example: 123MSDCF and 123ABCDE). Select another folder [\[Details\]](#), or create a new folder [\[Details\]](#).
-

Cannot create more folders

- The folder with a name beginning with “999” exists on the memory card. You cannot create any folders if this is the case.
-

Empty folder contents

- You tried to delete a folder containing one or more files. Delete all of the files and then delete the folder.
-

Folder protected

- You tried to delete a folder that is protected as read only on a computer.
-

File Error.

- An error occurred while the image was playing back.

No guarantees are made for playing back, on this camera, files containing images which were processed on a computer or images which were shot using other cameras.

Read only folder

- You have selected a folder that cannot be set as a recording folder on the camera. Select another folder. [\[Details\]](#)
-

File protected

- Release the protection. [\[Details\]](#)
-

Image size over limit

- You are playing back an image with size that cannot be played back on the camera.
-

Unable to detect face for retouch

- You may not be able to retouch the image depending on the image.
-

(Vibration warning indicator)

- Camera shake may occur due to insufficient light. Use the flash, or mount the camera on a tripod to secure the camera.
-

MP4 12M is not supported with this memory card.

MP4 6M is not supported with this memory card.

- For recording movies, it is recommended that you use a “Memory Stick PRO Duo” (Mark2) media, a “Memory Stick PRO-HG Duo” media or an SD card (Class 4 or faster).
-

Turn the power off and on again

- The lens malfunction.
-

Maximum number of images already selected.

- Up to 10 files can be selected when using [TransferJet].
 - Up to 100 files can be selected when using [Multiple Images].
 - You can add **DPOF** (Print order) marks to up to 999 files.
-

Error Playing Music

- Delete the Music file, or replace it with a normal Music file.
 - Execute [Empty Music], then download a new Music file.
-

Error Formatting Music

- Execute [Empty Music].
-

Operation cannot be executed in unsupported files.

-

- Processing and other editing functions of the camera cannot be performed on image files that have been processed using a computer or images that were recorded with other cameras.

Preparing image database file. Please wait.

- The camera restores the date information, etc., in cases where images have been deleted on a PC, etc.
- The necessary Image Database File is created after the memory card is formatted.



- The number of images exceeds that for which date management in a database file by the camera is possible. To register additional images in the Image Database File, delete images in [Date View].

Inconsistencies found in image database file. Recover data.

- AVCHD movies cannot be recorded or played because the Image Database File is corrupt. Follow the on-screen instructions to recover the Image Database File.



- It is not possible to record to the camera's Image Database File or play back using [Date View]. Use "PMB" to back up all images to a PC and use it to restore a memory card.

Image Database File error. Cannot recover data.

- Import all of the images to the computer with "PMB", and format the memory card or the internal memory.
To view the images again with the camera, export the imported images to the camera with "PMB". [\[Details\]](#)

Recording function unavailable due to high internal temperature.

- The camera temperature has risen. You cannot record images until the temperature has gone down.

Recording has stopped due to increased camera temperature.

- Recording has stopped due to a rise in temperature while recording a movie. Please wait until the temperature goes down.



- When you record movies for a long time, the camera temperature rises. In this case, stop recording movies.

Connection failed

- Check the TransferJet reception port and transfer data correctly. [\[Details\]](#)

Some files were not sent Some files were not received



- Either communication was cut off during image transfer, or transfer was cut off because device memory is full. Check the available memory capacity and try transferring data using TransferJet again.
- You may not be able to receive the image depending on the image.

[▲ Back to top](#)

Copyright 2011 Sony Corporation

▶ Operation Search
▶ Before Use
▶ Shooting
▶ Viewing
▶ Using 3D Functions
▶ Using MENU items (Shooting)
▶ Using MENU items (Viewing)
▶ Changing settings
▶ Viewing images on a TV
▶ Using with your computer
▶ Printing
▶ Troubleshooting
▶ Precautions/About this camera

[→ Contents list](#)

Precautions

- ▼ [Internal memory and memory card back up](#)
- ▼ [On database files](#)
- ▼ [Do not use/store the camera in the following places](#)
- ▼ [On carrying](#)
- ▼ [On operating temperatures](#)
- ▼ [On moisture condensation](#)
- ▼ [Functions built into this camera](#)
- ▼ [On image data compatibility](#)
- ▼ [Notes when playing movies on other devices](#)
- ▼ [Notes on the LCD screen and lens](#)

Internal memory and memory card back up

Do not turn off the camera, remove the battery pack, or remove the memory card while the access lamp is lit. Otherwise, the internal memory data or the memory card may be damaged. Be sure to make a backup copy to protect your data.

On database files

When you insert a memory card without a database file into the camera and turn on the power, part of the memory card capacity is used to automatically create a database file. It may take some time until you can perform the next operation.

Do not use/store the camera in the following places

- In an extremely hot, cold or humid place
In places such as in a car parked in the sun, the camera body may become deformed and this may cause a malfunction.
- Under direct sunlight or near a heater
The camera body may become discolored or deformed, and this may cause a malfunction.
- In a location subject to rocking vibration
- Near strong magnetic place
- In sandy or dusty places
Be careful not to let sand or dust get into the camera. This may cause the camera to malfunction, and in some cases this malfunction cannot be repaired.

On carrying

- Do not sit down in a chair or other place with the camera in the back pocket of your trousers or skirt, as this may cause malfunction or damage the camera.

On operating temperatures

- Your camera is designed for use under the temperatures between 0°C and 40°C (32°F and 104°F). Shooting in extremely cold or hot places that exceed this range is not recommended.

On moisture condensation

- If the camera is brought directly from a cold to a warm location, moisture may condense inside or outside the camera. This moisture condensation may cause a malfunction of the camera.
- If moisture condensation occurs, turn off the camera and wait about an hour for the moisture to evaporate. Note that if you attempt to shoot with moisture remaining inside the lens, you will be unable to record clear images.

Functions built into this camera

- This manual describes each of the functions of TransferJet-compatible/incompatible devices, 1080 60i-compatible devices and 1080 50i-compatible devices.
To check if your camera supports the TransferJet function, and whether it is a 1080 60i-compatible device or 1080 50i-compatible device, check for the following marks on the bottom of the camera.

TransferJet-compatible device:  (TransferJet)

1080 60i-compatible device: 60i

1080 50i-compatible device: 50i

- In an airplane, make sure to turn off the camera following cabin announcements.
- Do not watch 3D images shot with this camera for extended periods of time on 3D-compatible monitors.
- When you view 3D images shot with this camera on a 3D-compatible monitors, you may experience discomfort in the form of eye strain, fatigue, or nausea. To prevent these symptoms, we recommend that you take regular breaks.
However, you need to determine for yourself the length and frequency of breaks you require, as they vary according to the individual. If you experience any type of discomfort, stop viewing the 3D images until you feel better, and consult a physician as necessary. Also refer to the operating instructions supplied with the device or software you have connected or are using with this camera. Note that a child's eyesight is still at the development stage (particularly children below the age of 6). Consult a pediatrician or ophthalmologist before letting your child view 3D images, and make sure he/she observes the above precautions when viewing such images.

On image data compatibility

- The camera conforms with DCF (Design rule for Camera File system) universal standard established by JEITA (Japan Electronics and Information Technology Industries Association).
- Sony does not guarantee that the camera will play back images recorded or edited with other equipment, or that other equipment will play back images recorded with the camera.

Notes when playing movies on other devices

- This camera uses MPEG-4 AVC/H.264 High Profile for AVCHD format recording. Movies recorded in AVCHD format with this camera cannot be played by the following devices.
 - Other devices compatible with AVCHD format that does not support High Profile
 - Devices incompatible with the AVCHD formatThis camera also uses MPEG-4 AVC/H.264 Main Profile for MP4 format recording. For this reason, movies recorded in MP4 format with this camera cannot be played on devices other than those that support MPEG-4 AVC/H.264.
- You can play a high-definition image quality (HD) disc only on AVCHD format playback devices. A DVD player or DVD recorder cannot play back a disc recorded in high-definition image quality (HD) because they are not compatible with the AVCHD format. In addition, if you insert a high-definition image quality (HD) disc recorded in AVCHD format into a DVD player or DVD recorder, you may not be able to eject the disc.

Notes on the LCD screen and lens

- The LCD screen is manufactured using extremely high-precision technology so over 99.99%

of the pixels are operational for effective use. However, some tiny black and/or bright dots (white, red, blue or green) may appear on the LCD screen. These dots are a normal result of the manufacturing process and do not affect the recording.

- Exposing the LCD screen or the lens to direct sunlight for long periods may cause malfunctions. Be careful when placing the camera near a window or outdoors.
- Do not press against the LCD screen. The screen may be discolored and that may cause a malfunction.
- Images may trail across on the LCD screen in a cold location. This is not a malfunction.
- Be careful not to bump the movable lens, and be careful not to apply force to it.

[▲ Back to top](#)

Copyright 2011 Sony Corporation

[Top page](#) > [Precautions/About this camera](#) > [Precautions](#) > [On the internal rechargeable backup battery](#)

On the internal rechargeable backup battery

This camera has an internal rechargeable battery for maintaining the date and time and other settings regardless of whether the power is on or off.

This rechargeable battery is continually charged as long as you are using the camera. However, if you use the camera for only short periods, it discharges gradually, and if you do not use the camera at all for about one month it becomes completely discharged. In this case, be sure to charge this rechargeable battery before using the camera.

However, even if this rechargeable battery is not charged, you can still use the camera, but the date and time will not be indicated.

Charging method of the internal rechargeable backup battery

Insert charged battery pack in the camera, and then leave the camera for 24 hours or more with the power off.

[▲ Back to top](#)

- ▶ Operation Search
- ▶ Before Use
- ▶ Shooting
- ▶ Viewing
- ▶ Using 3D Functions
- ▶ Using MENU items (Shooting)
- ▶ Using MENU items (Viewing)
- ▶ Changing settings
- ▶ Viewing images on a TV
- ▶ Using with your computer
- ▶ Printing
- ▶ Troubleshooting
- ▶ Precautions/About this camera

[➡ Contents list](#)

Copyright 2011 Sony Corporation

▶ Operation Search
▶ Before Use
▶ Shooting
▶ Viewing
▶ Using 3D Functions
▶ Using MENU items (Shooting)
▶ Using MENU items (Viewing)
▶ Changing settings
▶ Viewing images on a TV
▶ Using with your computer
▶ Printing
▶ Troubleshooting
▶ Precautions/About this camera

[→ Contents list](#)

Battery pack

- ▼ [On charging the battery pack](#)
- ▼ [Effective use of the battery pack](#)
- ▼ [Remaining battery charge](#)
- ▼ [How to store the battery pack](#)
- ▼ [On battery life](#)
- ▼ [Compatible battery pack](#)

On charging the battery pack

- Charge the battery pack (supplied) before using the camera for the first time.
- You can charge the battery pack even if it is not completely discharged. In addition, even if the battery pack is not fully charged, you can use the partially charged capacity of the battery pack as is.
- We recommend charging the battery pack in an ambient temperature of between 10°C to 30°C (50°F to 86°F). The battery pack may not be effectively charged in temperatures outside this range.

Effective use of the battery pack

- Battery performance decreases in low temperature surroundings. So in cold places, the operational time of the battery pack is shorter. We recommend the following to ensure longer battery pack use:
 - Put the battery pack in a pocket close to your body to warm it up, and insert it in the camera immediately before you start shooting.
(If there are any metal objects such as keys in your pocket, be aware of short-circuits.)
- The battery pack will run out quickly if you use the flash or zoom frequently.
- We recommend having spare battery packs handy for two times or three times the expected shooting time, and making trial shots before taking the actual shots.
- Do not expose the battery pack to water. The battery pack is not water-resistant.
- Do not leave the battery pack in extremely hot places, such as in a car or under direct sunlight.
- You may not be able to turn on the camera or the battery pack may not be effectively charged if the terminal section of the battery is dirty. In this case, wipe any dust off lightly using a soft cloth or a cotton swab to clean the battery.

Remaining battery charge

- A remaining charge indicator appears on the LCD screen.

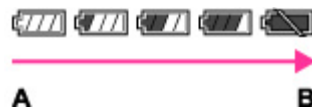
**A:** High**B:** Low

- It takes about one minute until the correct remaining charge indicator appears.

- The remaining charge indicator may not be correct under certain circumstances.
- When [Power Save] is set to [Standard] or [Stamina], if you do not operate the camera for a certain period of time while the power is on, the LCD screen becomes dark, then the camera turns off automatically (Auto power-off function).

How to store the battery pack

- Fully discharge the battery pack before storing and store it in a cool, dry place. To maintain the battery pack's function, charge the battery pack and then fully discharge it on the camera at least once a year while storing.
- To use the battery pack up, leave the camera in slideshow playback mode until the power goes off.
- To prevent staining the terminal, short-circuiting, etc., be sure to use a plastic bag, etc. to keep away from metal materials when carrying or storing.

On battery life

- The battery life is limited. Battery capacity decreases over time and through repeated use. If decreased usage time between charges becomes significant, it is probably time to replace it with a new one.
- The battery life varies according to how it is stored and the operating conditions and environment in which each battery pack is used.

Compatible battery pack

- The NP-BN1 (supplied) can be used only in N type compatible Cyber-shot models.

[▲ Back to top](#)

Copyright 2011 Sony Corporation

▶ Operation Search
▶ Before Use
▶ Shooting
▶ Viewing
▶ Using 3D Functions
▶ Using MENU items (Shooting)
▶ Using MENU items (Viewing)
▶ Changing settings
▶ Viewing images on a TV
▶ Using with your computer
▶ Printing
▶ Troubleshooting
▶ Precautions/About this camera

[→ Contents list](#)

AC Adaptor

- The supplied AC Adaptor is dedicated to this camera. Do not connect with other electronic devices. Doing so may cause a malfunction. Also, make sure to use a genuine Sony AC Adaptor.
- If the Power/charge lamp of the camera flashes during charging, remove the battery pack being charged, and then insert the same battery pack into the camera securely again. If the Power/charge lamp flashes again, this may indicate a battery error or that a battery pack other than the specified type has been inserted. Check that the battery pack is the specified type. If the battery pack is the specified type, remove the battery pack, replace it with a new or different one and check that the battery is charged correctly. If the battery is charged correctly, a battery error may have occurred.
- If the Power/charge lamp does not light even if the AC Adaptor is connected to the camera and the wall outlet (wall socket), this indicates that the charging has stopped temporarily and is on standby. Charging stops and enters standby status automatically when the temperature is outside of the recommended operating temperature. When the temperature returns to the appropriate range, charging resumes and the Power/charge lamp lights up again. We recommend charging the battery pack in an ambient temperature of between 10°C to 30°C (50°F to 86°F).
- Using the supplied AC Adaptor, you can charge the battery pack inserted in the camera. In addition, power supply via AC Adaptor in playback mode is also available. However, in shooting mode, power supply via AC Adaptor is not available. You need an AC-LS5 AC Adaptor (sold separately) and a VMC-MD3 Cable for multi-use terminals (sold separately) to have a power supply from the wall outlet (wall socket) during shooting.

[▲ Back to top](#)

▶ Operation Search
▶ Before Use
▶ Shooting
▶ Viewing
▶ Using 3D Functions
▶ Using MENU items (Shooting)
▶ Using MENU items (Viewing)
▶ Changing settings
▶ Viewing images on a TV
▶ Using with your computer
▶ Printing
▶ Troubleshooting
▶ Precautions/About this camera

[→ Contents list](#)

Memory card

▼ Memory card

▼ Note on using the memory card adaptor (sold separately)

▼ “Memory Stick” media

▼ When using a “Memory Stick Duo” media with standard sized “Memory Stick” media slot

▼ Notes on using a “Memory Stick Micro” media (sold separately)

Memory card

The types of memory cards that can be used with the camera are “Memory Stick PRO Duo” media, “Memory Stick PRO-HG Duo” media, “Memory Stick Duo” media, SD memory card, SDHC memory card and SDXC memory card.

MultiMediaCard cannot be used.

In this User Guide, “Memory Stick PRO Duo” media, “Memory Stick PRO-HG Duo” media and “Memory Stick Duo” media are called “Memory Stick Duo” media and SD memory cards, SDHC memory cards and SDXC memory cards are called SD cards.

- “Memory Stick Duo” media of up to 32 GB and SD cards of up to 64 GB have been tested and proven to operate with your camera.
- When recording movies, it is recommended that you use the following memory cards:
 - **MEMORY STICK PRO DUO** (Mark2) (“Memory Stick PRO Duo” (Mark2) media)
 - **MEMORY STICK PRO-HG DUO** (“Memory Stick PRO-HG Duo” media)
 - SD card (Class 4 or faster)

Notes

- To ensure stable operations of the memory card, we recommend that you use this camera to format any memory card being used with this camera for the first time. Note that formatting will erase all data recorded on the memory card. This data cannot be restored. Be sure to backup any important data to a PC or other storage location.
- If you repeatedly record/delete images, fragmentation of data may occur on the memory card. Movies may not be able to be saved or recorded. In such a case, save your images to a PC or other storage location, then [Format].
- A memory card formatted with a computer is not guaranteed to operate with the camera.
- Data read/write speeds differ depending on the combination of the memory card and the equipment used.
- Data may be corrupted in the following cases:
 - When the memory card is removed or the camera is turned off during a read or write operation
 - When the memory card is used in locations subject to static electricity or electrical noise
- We recommend backing up important data.
- Do not attach a label on the memory card itself nor on a memory card adaptor.
- Do not touch the terminal section of the memory card with your hand or a metal object.
- Do not strike, bend or drop the memory card.
- Do not disassemble or modify the memory card.
- Do not expose the memory card to water.
- Do not leave the memory card within the reach of small children. They might accidentally swallow it.
- Insert a memory card that fits the memory card slot size. Otherwise, it will cause a malfunction.
- Do not use or store the memory card under the following conditions:

- High temperature locations such as the hot interior of a car parked in direct sunlight
- Locations exposed to direct sunlight
- Humid locations or locations with corrosive substances present

Note on using the memory card adaptor (sold separately)

- When inserting a memory card into a memory card adaptor, make sure the memory card is inserted facing in the correct direction, then insert it all the way in. Incorrect insertion may result in a malfunction.

“Memory Stick” media

The types of “Memory Stick Duo” media that can be used with the camera are listed in the table below. However, proper operation cannot be guaranteed for all “Memory Stick Duo” media functions.

“Memory Stick” media type	Recording/Playback
Memory Stick Duo (without MagicGate)	○ *1
Memory Stick Duo (with MagicGate)	○ *2
MagicGate Memory Stick Duo	○ *1*2
Memory Stick PRO Duo	○ *2*3
Memory Stick PRO-HG Duo	○ *2*3*4

*1 High-speed data transfer using a parallel interface is not supported.

*2 “Memory Stick Duo” media, “MagicGate Memory Stick Duo” media, “Memory Stick PRO Duo” media and “Memory Stick PRO-HG Duo” media are equipped with MagicGate functions. MagicGate is copyright protection technology that uses encryption technology. Data recording/playback that requires MagicGate functions cannot be performed with the camera.

*3 Movies recorded in AVCHD format, [MP4 12M] and [MP4 6M] size movies cannot be recorded to “Memory Stick” media other than “Memory Stick PRO Duo” media or “Memory Stick PRO-HG Duo” media.

*4 This camera does not support 8-bit parallel data transfer. It performs the same 4-bit parallel data transfer as the “Memory Stick PRO Duo” media or “Memory Stick PRO-HG Duo” media.

When using a “Memory Stick Duo” media with standard sized “Memory Stick” media slot

You can use the “Memory Stick Duo” media by inserting it into the “Memory Stick Duo” media Adaptor (sold separately).



“Memory Stick Duo” media Adaptor

Notes on using a “Memory Stick Micro” media (sold separately)

- This product is compatible with “Memory Stick Micro” media (“M2”). “M2” is an abbreviation for “Memory Stick Micro” media.
- To use a “Memory Stick Micro” media with the camera, be sure to insert the “Memory Stick Micro” media into an “M2” Adaptor as large as of Duo size. If you insert a “Memory Stick Micro” media into the camera without an “M2” Adaptor as large as of Duo size, you might not

be able to remove it from the camera.

- Do not leave the “Memory Stick Micro” media within the reach of small children. They might accidentally swallow it.

[▲ Back to top](#)

Copyright 2011 Sony Corporation

- ▶ Operation Search
- ▶ Before Use
- ▶ Shooting
- ▶ Viewing
- ▶ Using 3D Functions
- ▶ Using MENU items (Shooting)
- ▶ Using MENU items (Viewing)
- ▶ Changing settings
- ▶ Viewing images on a TV
- ▶ Using with your computer
- ▶ Printing
- ▶ Troubleshooting
- ▶ Precautions/About this camera

[→ Contents list](#)

On cleaning

Cleaning the LCD screen

Wipe the screen surface with an LCD cleaning kit (sold separately) to remove fingerprints, dust, etc.

Cleaning the lens

Wipe the lens with a soft cloth to remove fingerprints, dust, etc.

Cleaning the flash

Clean the flash surface before use. The heat of flash emission may cause dirt on the flash surface to become discolored or to stick to the flash surface, resulting in insufficient light emission.

Cleaning the camera surface

Clean the camera surface with a soft cloth slightly moistened with water, then wipe the surface with a dry cloth. To prevent damage to the finish or casing:

- Do not expose the camera to chemical products such as thinner, benzene, alcohol, disposable cloths, insect repellent, sunscreen or insecticide.
- Do not touch the camera with any of the above on your hand.
- Do not leave the camera in contact with rubber or vinyl for a long time.

[▲ Back to top](#)

[Top page](#) > [Precautions/About this camera](#) > [Number of still images and recordable time of movies](#) > [Number of still images](#)

Number of still images

The number of still images may vary depending on the shooting conditions and the memory card.
(Units: Images)

Size	Internal memory	Memory card formatted with this camera				
	Approx. 19 MB	2 GB	4 GB	8 GB	16 GB	32 GB
16M	3	335	670	1350	2700	5400
10M	4	430	860	1700	3450	7000
5M	7	730	1450	2950	5900	11500
VGA	98	9600	19000	38500	40000	40000
16:9(12M)	3	355	710	1400	2850	5700
16:9(2M)	21	2100	4250	8600	17000	34500

Notes

- When the number of remaining shootable images is greater than 9,999, the ">9999" indicator appears.
- When an image shot with other cameras is played back on this camera, the image may not appear in the actual image size.

▶ Operation Search
▶ Before Use
▶ Shooting
▶ Viewing
▶ Using 3D Functions
▶ Using MENU items (Shooting)
▶ Using MENU items (Viewing)
▶ Changing settings
▶ Viewing images on a TV
▶ Using with your computer
▶ Printing
▶ Troubleshooting
▶ Precautions/About this camera

[➡ Contents list](#)

[▲ Back to top](#)

- ▶ Operation Search
- ▶ Before Use
- ▶ Shooting
- ▶ Viewing
- ▶ Using 3D Functions
- ▶ Using MENU items (Shooting)
- ▶ Using MENU items (Viewing)
- ▶ Changing settings
- ▶ Viewing images on a TV
- ▶ Using with your computer
- ▶ Printing
- ▶ Troubleshooting
- ▶ Precautions/About this camera

[➡ Contents list](#)

Recordable time of movies

The table below shows the approximate maximum recording times. These are the total times for all movie files. The recordable time may vary depending on the shooting conditions and the memory card.

(h (hour), m (minute))

Quality/Size	Internal memory	Memory card formatted with this camera				
	Approx. 19 MB	2 GB	4 GB	8 GB	16 GB	32 GB
AVC HD 24M (FX)	—	10m (10m)	20m (20m)	40m (40m)	1h 30m (1h 30m)	3h (3h)
AVC HD 17M (FH)	—	10m (10m)	30m (30m)	1h (1h)	2h (2h)	4h 5m (4h 5m)
AVC HD 9M (HQ)	—	25m (15m)	50m (40m)	1h 45m (1h 20m)	3h 35m (2h 45m)	7h 20m (5h 30m)
MP4 12M	—	15m	40m	1h 20m	2h 45m	5h 30m
MP4 6M	—	35m	1h 15m	2h 40m	5h 20m	10h 50m
MP4 3M	—	1h 10m	2h 25m	4h 55m	9h 55m	20h

The number in () is the minimum recordable time.

Continuous shooting is possible for approximately 29 minutes at one time. The maximum size of an MP4-format movie file is up to approximately 2 GB.

Note

- The recordable time of movies varies because the camera is equipped with VBR (Variable Bit Rate), which automatically adjusts image quality depending on the shooting scene. When you record a fast-moving subject, the image is clearer but the recordable time is shorter because more memory is required for recording. The recordable time also varies depending on the shooting conditions, the subject or the image quality/size settings.

[▲ Back to top](#)

[Top page](#) > [Precautions/About this camera](#) > [Using the camera abroad](#) > [Using the camera abroad](#)

Using the camera abroad

You can use the AC Adaptor (supplied) in any country or region where the power supply is within 100 V to 240 V AC, 50/60 Hz.

Note

- An electronic voltage transformer is unnecessary and its use may cause a malfunction.

[▲ Back to top](#)

- ▶ Operation Search
- ▶ Before Use
- ▶ Shooting
- ▶ Viewing
- ▶ Using 3D Functions
- ▶ Using MENU items (Shooting)
- ▶ Using MENU items (Viewing)
- ▶ Changing settings
- ▶ Viewing images on a TV
- ▶ Using with your computer
- ▶ Printing
- ▶ Troubleshooting
- ▶ Precautions/About this camera

[→ Contents list](#)

Copyright 2011 Sony Corporation

[Top page](#) > [Precautions/About this camera](#) > [Using the camera abroad](#) > [On TV color systems](#)

On TV color systems

To view movies shot using this camera on a television, the camera and television must use the same color television system. Check the color TV system for the country or region where you are using the camera.

NTSC system

Bahama Islands, Bolivia, Canada, Central America, Chile, Colombia, Ecuador, Jamaica, Japan, Korea, Mexico, Peru, Surinam, Taiwan, the Philippines, the U.S.A., Venezuela, etc.

PAL system

Australia, Austria, Belgium, China, Croatia, Czech Republic, Denmark, Finland, Germany, Holland, Hong Kong, Hungary, Indonesia, Italy, Kuwait, Malaysia, New Zealand, Norway, Poland, Portugal, Romania, Singapore, Slovak Republic, Spain, Sweden, Switzerland, Thailand, Turkey, United Kingdom, Viet Nam, etc.

PAL-M system

Brazil

PAL-N system

Argentina, Paraguay, Uruguay

SECAM system

Bulgaria, France, Greece, Guiana, Iran, Iraq, Monaco, Russia, Ukraine, etc.

▶ Operation Search
▶ Before Use
▶ Shooting
▶ Viewing
▶ Using 3D Functions
▶ Using MENU items (Shooting)
▶ Using MENU items (Viewing)
▶ Changing settings
▶ Viewing images on a TV
▶ Using with your computer
▶ Printing
▶ Troubleshooting
▶ Precautions/About this camera

[➡ Contents list](#)

[▲ Back to top](#)

Intelligent Pantilter

Intelligent Pantilter (sold separately) allows you to take pictures automatically, by having the camera detect people's faces.

For details, see the operating instructions supplied with Intelligent Pantilter.

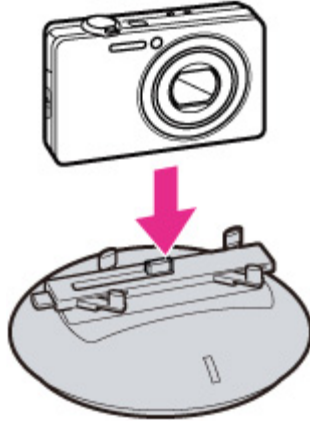

- ▶ [Operation Search](#)
- ▶ [Before Use](#)
- ▶ [Shooting](#)
- ▶ [Viewing](#)
- ▶ [Using 3D Functions](#)
- ▶ [Using MENU items \(Shooting\)](#)
- ▶ [Using MENU items \(Viewing\)](#)
- ▶ [Changing settings](#)
- ▶ [Viewing images on a TV](#)
- ▶ [Using with your computer](#)
- ▶ [Printing](#)
- ▶ [Troubleshooting](#)
- ▶ [Precautions/About this camera](#)

[➔ Contents list](#)

[▲ Back to top](#)

- ▶ Operation Search
- ▶ Before Use
- ▶ Shooting
- ▶ Viewing
- ▶ Using 3D Functions
- ▶ Using MENU items (Shooting)
- ▶ Using MENU items (Viewing)
- ▶ Changing settings
- ▶ Viewing images on a TV
- ▶ Using with your computer
- ▶ Printing
- ▶ Troubleshooting
- ▶ Precautions/About this camera

[➡ Contents list](#)

Carl Zeiss lens

The camera is equipped with a Carl Zeiss lens which is capable of reproducing sharp images with excellent contrast. The lens for the camera has been produced under a quality assurance system certified by Carl Zeiss in accordance with the quality standards of Carl Zeiss in Germany.

[▲ Back to top](#)

▶ Operation Search
▶ Before Use
▶ Shooting
▶ Viewing
▶ Using 3D Functions
▶ Using MENU items (Shooting)
▶ Using MENU items (Viewing)
▶ Changing settings
▶ Viewing images on a TV
▶ Using with your computer
▶ Printing
▶ Troubleshooting
▶ Precautions/About this camera

[➡ Contents list](#)

AVCHD format

The AVCHD format has been developed for high-definition digital video cameras when recording an HD (High-Definition) signal at the 1080i*¹ or 720p*² specification using high-efficiency compression coding technology. The MPEG-4 AVC/H.264 format is adopted to compress video data, and the Dolby Digital or Linear PCM system is used to compress audio data.

The MPEG-4 AVC/H.264 format is capable of compressing images at higher efficiency than that of the conventional image compressing format. The MPEG-4 AVC/H.264 format enables a high definition video signal shot on a digital video camera recorder to be recorded on 8 cm DVD discs, hard disk drive, flash memory, memory card, etc.

Recording and playback on the camera

Based on the AVCHD format, your camera records with the high definition image quality (HD) mentioned below.

Video signal*³:

1080 60i-compatible device

MPEG-4 AVC/H.264 1920×1080/60i, 1440×1080/60i

1080 50i-compatible device

MPEG-4 AVC/H.264 1920×1080/50i, 1440×1080/50i

Audio signal: Dolby Digital 2ch

Recording media: Memory card

*1 1080i specification

A high definition specification which utilizes 1,080 effective scanning lines and the interlace system.

*2 720p specification

A high definition specification which utilizes 720 effective scanning lines and the progressive system.

*3 Data recorded in AVCHD format other than the above mentioned cannot be played on your camera.

[▲ Back to top](#)

▶ Operation Search
▶ Before Use
▶ Shooting
▶ Viewing
▶ Using 3D Functions
▶ Using MENU items (Shooting)
▶ Using MENU items (Viewing)
▶ Changing settings
▶ Viewing images on a TV
▶ Using with your computer
▶ Printing
▶ Troubleshooting
▶ Precautions/About this camera

[➡ Contents list](#)

TransferJet standard

TransferJet communications conform to the standard given below.

TransferJet standard:

Conforms to PCL Spec. Rev. 1.0

Protocol Class Name (communication type):

SCSI Block Device Target

OBEX Push Server

OBEX Push Client

- Use the “SCSI” communication protocol above when connecting to a TransferJet-compatible device (sold separately). Or, use the “OBEX” communication protocol when sharing data between cameras.

[▲ Back to top](#)

▶ Operation Search
▶ Before Use
▶ Shooting
▶ Viewing
▶ Using 3D Functions
▶ Using MENU items (Shooting)
▶ Using MENU items (Viewing)
▶ Changing settings
▶ Viewing images on a TV
▶ Using with your computer
▶ Printing
▶ Troubleshooting
▶ Precautions/About this camera

[→ Contents list](#)

License

Notes on the License

“C Library”, “zlib” and “libjpeg” software are provided in the camera. We provide this software based on license agreements with their owners of copyright. Based on requests by the owners of copyright of these software applications, we have an obligation to inform you of the following. Please read the following sections.

Read “license3.pdf” in the “License” folder on the CD-ROM. You will find licenses (in English) of “C Library”, “zlib” and “libjpeg” software.

THIS PRODUCT IS LICENSED UNDER THE AVC PATENT PORTFOLIO LICENSE FOR THE PERSONAL AND NON-COMMERCIAL USE OF A CONSUMER TO

(i) ENCODE VIDEO IN COMPLIANCE WITH THE AVC STANDARD (“AVC VIDEO”) AND/OR

(ii) DECODE AVC VIDEO THAT WAS ENCODED BY A CONSUMER ENGAGED IN A PERSONAL AND NON-COMMERCIAL ACTIVITY AND/OR WAS OBTAINED FROM A VIDEO PROVIDER LICENSED TO PROVIDE AVC VIDEO.

NO LICENSE IS GRANTED OR SHALL BE IMPLIED FOR ANY OTHER USE.

ADDITIONAL INFORMATION MAY BE OBTAINED FROM MPEG LA, L.L.C. SEE

[HTTP://WWW.MPEGLA.COM](http://www.mpegla.com)

On GNU GPL/LGPL applied software

The software that is eligible for the following GNU General Public License (hereinafter referred to as “GPL”) or GNU Lesser General Public License (hereinafter referred to as “LGPL”) are included in the camera.

This informs you that you have a right to have access to, modify, and redistribute source code for these software programs under the conditions of the supplied GPL/LGPL.

Source code is provided on the web. Use the following URL to download it.

<http://www.sony.net/Products/Linux/>

We would prefer you do not contact us about the contents of source code.

Read “license2.pdf” in the “License” folder on the CD-ROM. You will find licenses (in English) of “GPL”, and “LGPL” software.

To view the PDF, Adobe Reader is needed. If it is not installed on your computer, you can download it from the Adobe Systems web page:

<http://www.adobe.com/>

[▲ Back to top](#)

▶ Operation Search
▶ Before Use
▶ Shooting
▶ Viewing
▶ Using 3D Functions
▶ Using MENU items (Shooting)
▶ Using MENU items (Viewing)
▶ Changing settings
▶ Viewing images on a TV
▶ Using with your computer
▶ Printing
▶ Troubleshooting
▶ Precautions/About this camera

[➡ Contents list](#)

Trademarks

- The following marks are trademarks of Sony Corporation.
Cyber-shot, “Cyber-shot,” “Memory Stick,” , “Memory Stick PRO,”
MEMORY STICK PRO, “Memory Stick Duo,” **MEMORY STICK DUO**, “Memory Stick PRO Duo,”
MEMORY STICK PRO DUO, “Memory Stick PRO-HG Duo,”
MEMORY STICK PRO-HG DUO, “Memory Stick Micro,” “MagicGate,” **MAGIC GATE**,
“BRAVIA,” “PhotoTV HD,” “DVDirect,” TransferJet and the TransferJet logo
- “Blu-ray Disc™” and “Blu-ray™” are trademarks of the Blu-ray Disc Association.
- “AVCHD” and “AVCHD” logotype are trademarks of Panasonic Corporation and Sony Corporation.
- Dolby and the double-D symbol are trademarks of Dolby Laboratories.
- HDMI, the HDMI logo and High-Definition Multimedia Interface are trademarks or registered trademarks of HDMI Licensing LLC.
- Microsoft, Windows, DirectX and Windows Vista are either registered trademarks or trademarks of Microsoft Corporation in the United States and/or other countries.
- Macintosh and Mac OS are trademarks or registered trademarks of Apple Inc.
- Intel, Pentium and Intel Core are trademarks or registered trademarks of Intel Corporation.
- SDXC logo is a trademark of SD-3C, LLC.
- MultiMediaCard is a trademark of MultiMediaCard Association.
- “PlayStation” is a registered trademark of Sony Computer Entertainment Inc.
- The OBEX word mark and logo are registered trademarks and are owned by Infrared Data Association (IrDA®).
- Eye-Fi is a trademark of Eye-Fi, Inc.
- In addition, system and product names used in this manual are, in general, trademarks or registered trademarks of their respective developers or manufacturers. However, the ™ or ® marks are not used in all cases in this manual.

[▲ Back to top](#)