

## Interchangeable Lens Digital Camera

**α Handbook**

---

Table of contents

---

Sample photo search

---

Menu search

---

Index



**α**

# How to use this handbook

Click on a button at upper right on the cover and each page to jump to the corresponding page.

This is convenient when searching for a function you want to use.

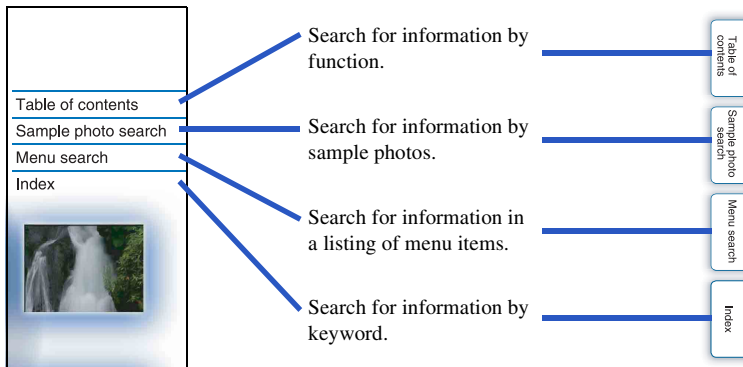

You can jump to the pages by clicking on the page numbers mentioned in the book.

## Marks and notations used in this handbook

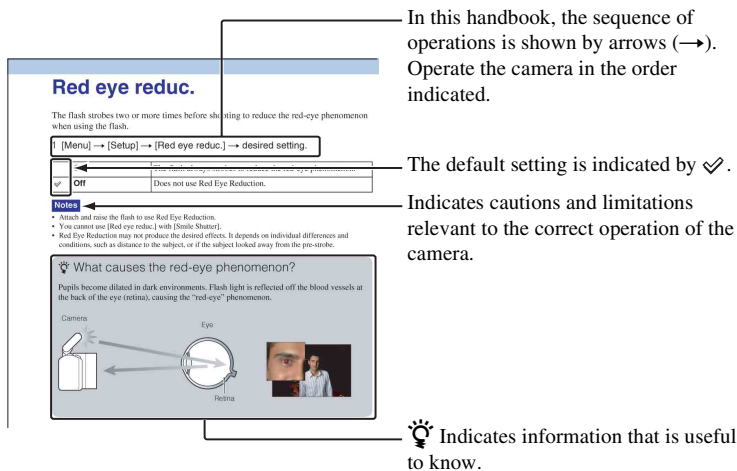

Table of contents

Sample photo search

Menu search

Index

# Table of contents

---

## Notes on using the camera

How to use this handbook .....	2
Sample photo search .....	5
Identifying parts .....	11
List of icons on the screen .....	15

---

## Basic operations

Using the control wheel and soft keys .....	17
Menu search .....	19
Shooting images .....	23
Playing back images .....	26
Deleting images .....	28

---

## Using functions with the control wheel

DISP (Display Contents) .....	29
⚡ (Flash Mode) .....	31
☑ (Exposure Comp.) .....	32
☺ / 📷 (Drive Mode) .....	33
📷 (Image Index) .....	40

---

## Using functions in the menu

Shoot Mode .....	19
Camera .....	20
Image Size .....	20
Brightness/Color .....	20
Playback .....	21
Setup .....	21

---

## Connecting with other equipment

Viewing images on a TV .....	123
Using with your computer .....	125
Using the software .....	127
Connecting the camera to the computer .....	130
Creating a movie disc (NEX-5/5C) .....	132
Printing still images .....	136

---

## Troubleshooting

Troubleshooting .....	137
Warning messages .....	143

---

## Others

Using the camera abroad .....	146
Memory card .....	147
“InfoLITHIUM” battery pack .....	149
Battery charger .....	151
Mount Adaptor .....	152
AVCHD format (NEX-5/5C) .....	153
Cleaning .....	154

---

## Index

Index .....	155
-------------	-----

# Sample photo search

“This is the scene I want to capture in a photo, but how can I do?”

You may find the answer by going through the sample photos listed here. Click the desired sample photo.

Shooting people (page 6)

Shooting macro photos (page 7)

Shooting landscapes (page 8)

Shooting sunset/night views (page 9)

Shooting fast moving subjects (page 10)

If you click on a photo, the screen will jump to the page describing the function recommended for shooting that kind of photo.

Refer to those descriptions in addition to the shooting tips displayed on the screen of the camera.



A happy smile (58)



## Smile Shutter

When the camera detects a smile, the shutter is released automatically.

- [Menu] → [Camera] → [Smile Shutter] → [On].
- Wait for a smile to be detected.  
When the smile level exceeds the ◀ point on the indicator, the camera records images automatically. If you press the shutter button during Smile Shutter shooting, the camera shoots the image, then returns to Smile Shutter mode.
- To exit Smile Shutter mode, [Menu] → [Camera] → [Smile Shutter] → [Off].

**Notes**

- You cannot use [Smile Shutter] with the following functions:
  - [Hand-held Night Shot] in [Scene Selection]
  - [Anti Motion Blur]
  - [Deep Playframes]
  - [ManualFocus]
  - [Precision Dig. Zoom]
- Shooting using the Smile Shutter ends automatically when the memory card becomes full.
- Smiles may not be detected correctly depending on the conditions.
- The drive mode turns to [Single-shot sds.] or [Burstmode Csl.] automatically.

**Tips for better capturing of smiles**



① Do not cover the eyes with the target.  
Do not obscure the face by a hat, masks, sunglasses, etc.

② Try to orient the face in front of the camera and be as level as possible.  
Keep the eyes narrowed.

③ Give a clear smile with an open mouth.  
The smile is easier to be detected when the teeth are shown.

- The shutter operates when any person whose smile is detected.
- If a smile is not detected, set the [Smile Detection] in the menu.

58<sup>th</sup>

Table of contents

Sample photo search

Menu search

Index

# Shooting people



Only the main subject is in focus by defocusing the background (24)

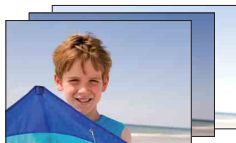

The same scene with different brightness (38)



A happy smile (59)



In candle light (45)



A person in front of night view (72)



A moving person (68)



A group photo (36, 37)



A person lit from behind (31)

Table of contents

Sample photo search

Menu search

Index

# Shooting macro photos



Defocusing the background (24)



Adjusting the color to indoor light (69)



Flowers (43)



Lowering the amount of flash light (72)



Focusing manually (53)



In better brightness (32)



Preventing camera shake for indoor shots (68)



Making food look appealing (32)

Table of contents

Sample photo search

Menu search

Index

# Shooting landscapes



The sky in vivid colors (32)



Running water (50)



Vivid green colors (75)



Colored leaves (75)



Panoramic photos (46)



Scenery with a wide range of brightness (73)



Light outdoors shot from a dark interior (73)



Defocusing the background (24)



Keeping your shot level (90)

Table of contents

Sample photo search

Menu search

Index

# Shooting sunset/night views



Holding the camera by hand (43)



Trail of light (31)



Fireworks (49)



Defocusing the background (24)



The same scene in different brightness (38)



Preventing camera shake (36)



Shooting the red of the sunset beautifully (43)

Table of contents

Sample photo search

Menu search

Index

# Shooting fast moving subjects



Following a moving subject (56)



Expressing vigorous action (50)



With the subject approaching the camera  
(53)



Capturing the best moment (35)

Table of contents

Sample photo search

Menu search

Index

# Identifying parts

## NEX-5/5C

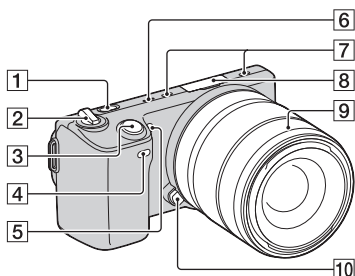

## NEX-3

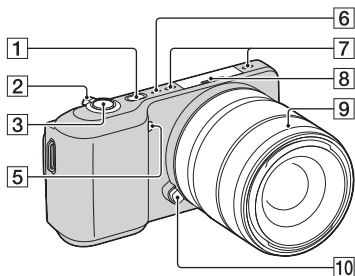

See the pages in parentheses for details of operation.

- 1  (Playback) button (26)
- 2 ON/OFF (Power) switch
- 3 Shutter button (23)
- 4 Remote sensor (39)
- 5 AF illuminator/Self-timer lamp/Smile Shutter lamp
- 6 Speaker
- 7 Microphone\*
- 8 Smart Accessory Terminal
- 9 Lens
- 10 Lens release button
- 11 Mount
- 12 Image sensor\*\*
- 13 Lens contacts\*\*

\* Do not cover this part during movie recording.

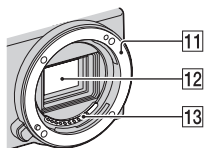

\*\* Do not touch this part directly.

### When the lens is removed (NEX-5/5C/3)

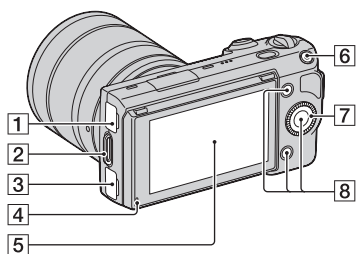

## NEX-5/5C



- 1  (USB) terminal (130)
- 2 Hook for shoulder strap
- 3 HDMI terminal (123)
- 4 Light sensor
- 5 LCD monitor
- 6 MOVIE button (23)
- 7 Control wheel (17)
- 8 Soft keys (18)
- 9  Image sensor position mark (53)

## NEX-3

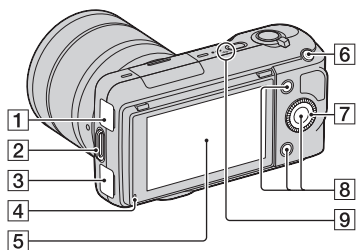

## NEX-5/5C

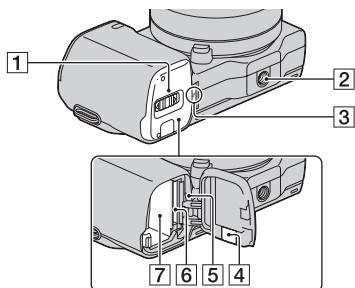

## NEX-3

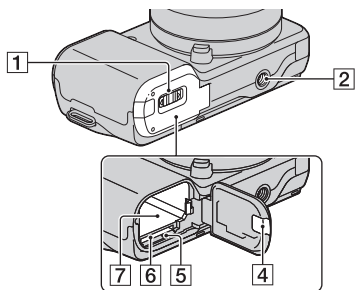

1 Battery/memory card cover

2 Tripod receptacle

- Use a tripod with a screw length of less than 5.5 mm (7/32 inch). You will be unable to firmly secure the camera to tripods having screws longer than 5.5 mm (7/32 inch), and may damage the camera.

3  Image sensor position mark (53)

4 Connection plate cover

- Use this when using an AC-PW20 AC Adaptor (sold separately). Insert the connection plate into the battery compartment, then pass the cord through the connection plate cover as shown below.

NEX-5/5C

NEX-3

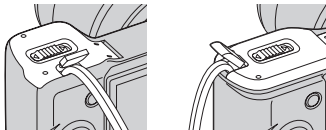

- Make sure that the cord is not pinched when you close the cover.

5 Access lamp

6 Memory card insertion slot

7 Battery compartment

## Flash

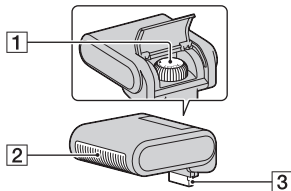

1 Screw

2 Flash

3 Connector\*

- \* Do not touch this part directly.

Table of contents

Sample photo search

Menu search

Index

## Lens

On the E18 – 200 mm lens, refer to the instruction manual of the E18 – 200 mm lens (supplied).

### E18 – 55 mm F3.5-5.6 OSS (supplied with NEX-5D/5CD/5K/5CK/3D/3K)

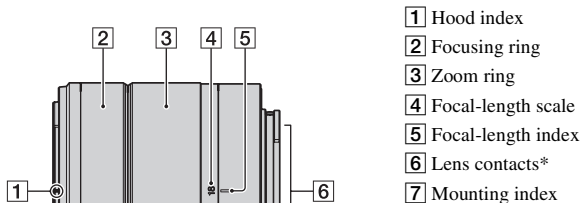

- 1 Hood index
- 2 Focusing ring
- 3 Zoom ring
- 4 Focal-length scale
- 5 Focal-length index
- 6 Lens contacts\*
- 7 Mounting index

\* Do not touch this part directly.

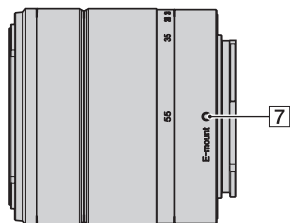

### E16 mm F2.8 (supplied with NEX-5A/5CA/3A)

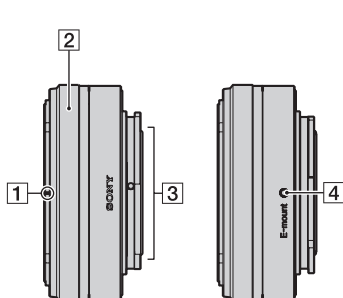

- 1 Converter index\*
- 2 Focusing ring
- 3 Lens contacts\*\*
- 4 Mounting index

\* A converter is sold separately.

\*\* Do not touch this part directly.

# List of icons on the screen

Icons are displayed on the screen to indicate the camera status.

You can change the screen display using DISP (Display Contents) on the control wheel (page 29).

## Shooting standby

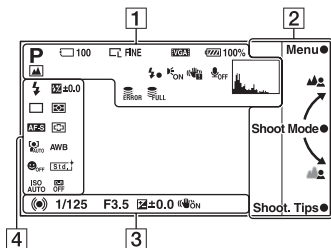

## Graphic display

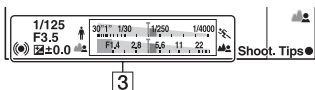

## Movie recording

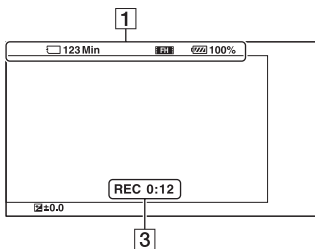

## Playback

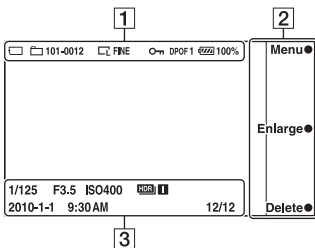

1

Display	Indication
PASM	Shoot Mode
	Scene Selection
 WIDE STD	Image size/Aspect ratio of still images
RAW RAW+J FINE STD	Image quality of still images
100	Number of recordable still images
FH 1080 VGA 720 FINE 720 STD	Image size of movies
	Memory card/Upload
123min	Recordable time of movies
100%	Remaining battery
	Scene Recognition icons
	Flash charge in progress
	AF illuminator
	Does not record sound during movie recording
	Camera shake warning

Table of contents

Sample photo search

Menu search

Index

Display	Indication
	Overheating warning
	Database file full/ Database file error
	Histogram
101-0012	Playback folder – File number
	Protect
DPOF 1	Print order and number of copies

2

Display	Indication
Menu ●	Soft keys
Shoot Mode ●	
Shoot. Tips ●	

3

Display	Indication
● (∞) (C)	Focus status
1/125	Shutter speed
F3.5	Aperture value
ISO400	ISO sensitivity
±0.0	Metered manual
±0.0	Exposure compensation
	Shutter speed indicator
	Aperture indicator
REC 0:12	Recording time of the movie (m:s)
2010-1-1 9:30AM	Recorded date/time of the image
12/12	Image number/Number of images recorded in the date or selected folder
	SteadyShot
	Appears when HDR did not work on the image.

4

Display	Indication
	Flash Mode/Red Eye Reduction
	Drive Mode
	Focus mode
±0.0	Flash compensation
	Metering Mode
	Focus area mode
	Face Detection
	Smile Shutter
ISO AUTO	ISO
	White Balance
	Creative Style
	DRO/Auto HDR
	Smile detection sensitivity indicator

Table of contents

Sample photo search

Menu search



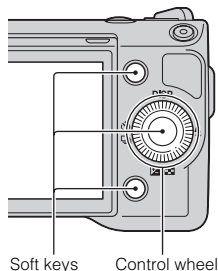

Index

# Using the control wheel and soft keys

The control wheel and soft keys allow you to use various functions of the camera.



## Control wheel

When shooting, DISP (Display Contents),  (Flash Mode),  (Exposure Comp.) and  /  (Drive Mode) functions are assigned to the control wheel. When playing back, DISP (Display Contents) and  (Image Index) functions are assigned to the control wheel.

When you turn or press the right/left/top/bottom parts of the control wheel following the on-screen display, you can select setting items. Your selection is determined when you press the center of the control wheel.

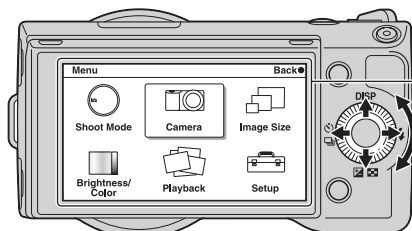
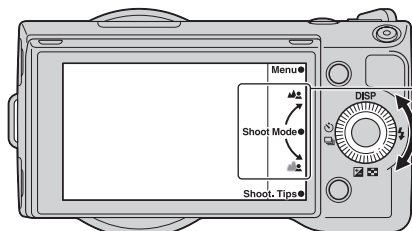

## Soft keys

The soft keys have different roles, depending on the context.

The assigned role (function) of each soft key is shown on the screen.

To use the function shown at the upper right corner of the screen, press soft key A. To use the function shown at the lower right corner of the screen, press soft key B. To use the function shown at the center, press the center of the control wheel (soft key C).

In this handbook, the soft keys are indicated by the icon or the function shown on the screen.

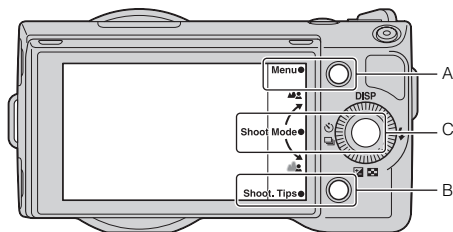

In this case, soft key A works as the [Menu] button, and soft key B as the [Shoot Tips] button. Soft key C works as the [Shoot Mode] button.

# Menu search

You can set up the basic settings for the camera as a whole, or execute functions such as shooting, playback, or other operations.

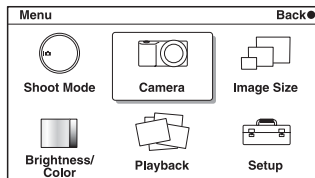

- 1 Press [Menu].
- 2 Select the desired item by pressing the top/bottom/left/right parts of the control wheel, and then press the center.
- 3 Following the instructions on the screen, select the desired item and press the center of the control wheel to make your choice.

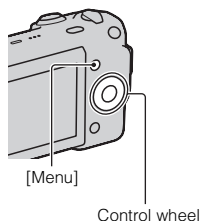

## Shoot Mode

Allows you to select a shooting mode, such as exposure mode, panoramic, Scene Selection.

Intelligent Auto	The camera evaluates the subject and makes the proper settings. You can enjoy automatic shooting with the appropriate settings.
Scene Selection	Shoots with preset settings according to the subject or condition.
Anti Motion Blur	Reduces the camera shake when shooting a slightly dark indoor scene or a telephoto.
Sweep Panorama	Shoots with panoramic size.
Manual Exposure	Adjusts the aperture and shutter speed.
Shutter Priority	Adjusts the shutter speed to express the movement of the subject.
Aperture Priority	Adjusts the range in focus, or defocuses the background.
Program Auto	Automatic shooting that allows you to customize settings, except for the exposure (shutter speed and aperture).

## Camera

Allows you to set shooting functions, such as continuous shooting, self-timer, and flash.

Drive Mode	Selects the drive mode, such as continuous shooting, self-timer, or bracket shooting.
Flash Mode	Selects the method used to fire the flash.
AF/MF Select	Selects auto focusing or manual focusing.
Autofocus Area	Selects the area to be focused on.
Autofocus Mode	Selects the autofocus method.
Precision Dig. Zoom	Sets the digital zoom when a single focus lens is used.
Face Detection	Detects people's faces automatically, and adjusts focus and exposure to suit the faces.
Smile Shutter	Each time the camera detects a smile, the camera releases the shutter automatically.
Smile Detection	Sets the sensitivity of the Smile Shutter function for detecting smiles.
Panorama Direction	Selects the direction to pan the camera when shooting panoramic images.
Shooting Tip List	Allows you to access all shooting tips.
Display Contents	Switches the information to be displayed on the shooting screen.

## Image Size

Allows you to set the image size and aspect ratio.

<b>Still</b>	
Image Size	Selects the image size.
Aspect Ratio	Selects the aspect ratio.
Quality	Selects the compression format.
<b>Panorama</b>	
Image Size	Selects the image size.
<b>Movie</b>	
File Format (NEX-5/5C)	Selects the movie recording format, AVCHD or MP4.
Image Size	Selects the image size.

## Brightness/Color

Allows you to make brightness settings such as metering mode, and color settings such as white balance.

Exposure Comp.	Compensates for the brightness of the entire image.
ISO	Sets the ISO sensitivity.

White Balance	Adjusts the color tones according to the ambient light conditions.
Metering Mode	Selects the method used for measuring the brightness.
Flash Compensation	Adjusts the amount of flash light.
DRO/Auto HDR	Corrects the brightness or contrast automatically.
Creative Style	Selects the image processing method.

## Playback

Allows you to set playback functions.

Delete	Deletes images.
Slide Show	Plays back images automatically.
Still/Movie Select	Selects a still image or movie to play back.
Image Index	Selects the number of images to be displayed on the index screen.
Select Folder	Selects the folder of still images to play back.
Select Date	Selects the date of movies to play back.
Rotate	Rotates images.
Protect	Protects images, or cancels the protection.
 Enlarge Image	Enlarges the image.
Volume Settings	Sets the sound volume of movies.
Specify Printing	Selects the images to print, or makes printing settings.
Display Contents	Switches the information to be displayed on the playback screen.

## Setup

Allows you to make more detailed shooting settings, or change the camera settings.

Shooting Settings	
AF Illuminator	Sets the AF illuminator to assist auto-focusing in dim places.
Red Eye Reduction	Provides pre-flash before shooting when using the flash, to prevent eyes from being shot in red.
Auto Review	Sets the display time of the image right after shooting.
Grid Line	Turns on the grid line that helps you to adjust the composition of images.
Histogram	Displays the histogram of the luminance distribution.
MF Assist	Displays an enlarged image when focusing manually.
Color Space	Changes the range of color reproduction.
SteadyShot	Sets camera shake compensation.
Release w/oLens	Sets whether or not to release the shutter when there is no lens.

Long Exposure NR	Sets the noise reduction processing for long exposure shootings.
High ISO NR	Sets the noise reduction processing for high ISO sensitivity shootings.
Movie Audio Rec	Sets the sound for movie recording.
<b>Main Settings</b>	
Beep	Selects the sound produced when you operate the camera.
 Language	Selects the language used on the screen.
Date/Time Setup	Sets the date and time.
Area Setting	Selects the area where you are using the camera.
Help Guide Display	Turns the Help Guide on or off.
Power Save	Sets the time to turn the camera to the power save mode.
LCD Brightness	Sets the brightness of the LCD monitor.
Display Color	Selects the color of the LCD monitor.
Wide Image	Selects a method to display wide images.
Playback Display	Selects the method used to play back portrait images.
CTRL FOR HDMI	Sets whether or not to operate the camera with a "BRAVIA" Sync compatible TV's Remote Control.
USB Connection	Selects the method used for a USB connection.
Cleaning Mode	Allows you to clean the image sensor.
Version	Displays the version of the camera and the lens.
Demo Mode	Sets whether or not to display the demonstration with movies.
Reset Default	Resets the camera to the factory-settings.
<b>Memory Card Tool</b>	
Format	Formats the memory card.
File Number	Selects the method used for assigning file numbers to images.
Folder Name	Selects the folder name format.
Select Shoot. Folder	Selects the recording folder.
New Folder	Creates a new folder.
Recover Image DB	Repairs the image database file of movies when inconsistencies are found.
Display Card Space*	Displays the remaining recording time of movies and the recordable number of still images on the memory card.
<b>Eye-Fi Setup**</b>	
Upload Settings	Sets the upload function of the camera when an Eye-Fi card is used.

\* Appears when a memory card (sold separately) is inserted in the camera.

\*\* Appears when an Eye-Fi card (sold separately) is inserted in the camera. NEX-5C does not have this function.

# Shooting images

Shooting images with the settings in effect when you bought the camera is explained here.

The camera makes decisions appropriate to the situation, and adjusts the settings.

## 1 Adjust the LCD monitor angle, and hold the camera.

The Scene Recognition function begins to work.

## 2 To take still images, press the shutter button.

To record movies, press the MOVIE button to start recording.

Press the MOVIE button again to stop recording.

### Notes

- The angle of view of movies is narrower than that of still images. After you press the MOVIE button, the camera shows the actual range to be recorded by displaying an empty frame on the screen. You can check the frame for movies by selecting [Menu] → [Setup] → [Grid Line] → [On].
- You can continuously record an AVCHD format movie for up to 29 minutes (NEX-5/5C only), and an MP4 format movie for up to 29 minutes or 2 GB. The recording time may vary depending on the ambient temperatures or recording conditions.

### 💡 On Scene Recognition



Scene Recognition icon and guide

The Scene Recognition function lets the camera automatically recognize the shooting conditions and allows you to shoot the image with appropriate settings.

- The camera recognizes 🌙 (Night View), 📷 (Tripod Night View), 🧑 (Night Portrait), 📷 (Backlight), 📷 (Backlight Portrait), 🧑 (Portrait), 🏔️ (Landscape), or 🌸 (Macro), and displays the corresponding icon and guide on the LCD monitor when the scene is recognized.

 If you shoot a still image of a subject that is difficult to focus on



When the camera cannot focus on the subject automatically, the focus indicator blinks. Either recompose the shot or change the focus setting.

Focus indicator

Focus indicator	Status
● lit	Focus locked.
⦿ lit	Focus is confirmed. Focal point moves following a moving subject.
⦿ lit	Still focusing.
● flashing	Cannot focus.

- Focusing may be difficult in the following situations:
  - It is dark and the subject is distant.
  - The contrast between the subject and the background is poor.
  - The subject is seen through glass.
  - The subject is moving quickly.
  - The subject reflects light such as mirror, or has shiny surfaces.
  - The subject is flashing.
  - The subject is backlit.

## Background Defocus Control

 (Intelligent Auto) allows you to defocus the background easily to make the subject stand out.

You can check the defocusing effect on the LCD monitor.



- 1 Press the center of the control wheel.
- 2 Defocus the background by turning the control wheel.

 : Turn up to focus

 : Turn down to defocus

Press [Back] to restore to the original status.

## Notes

- When the Scene Recognition function is enabled, the camera analyzes the scene when you press the center of the control wheel, and uses it as the Recognized Scene.
- The defocusing range available depends on the lens used.
- The defocusing effect may not be noticeable, depending on the distance from the subject or the lens used.
- The Background Defocus Control function does not operate when an A-mount lens is attached.

### For a better result of Background Defocus

- Move closer to the subject.
- Lengthen the distance between the subject and the background.

# Playing back images

Plays back the recorded images. Still images and movies are displayed on separate screens. You cannot display still images and movies on the same screen.

- 1 Press the  (Playback) button.
- 2 Select the image with the control wheel.
- 3 To play back panoramic images or movies, press the center of the control wheel.

During movie playback	Control wheel operation
To pause/resume	Press the center.
To fast-forward	Press the right, or turn it right.
To fast-rewind	Press the left, or turn it left.
To slow-forward (NEX-5/5C only)	Turn it right during pause.
To slow-reverse (NEX-5/5C only)	Turn it left during pause.
To adjust sound volume	Press the bottom $\rightarrow$ top/bottom.



## Note

- Panoramic images shot on other cameras may not be played back properly.

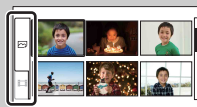

## Switching between the still image and movie



On the image index screen, you can switch the image type by selecting  (still image) or  (movie) on the left of the screen followed by pressing the center of the control wheel.

## Enlarged playback

A portion of a still image can be enlarged for closer examination during playback. This is convenient to check the focus condition of a recorded still image. You can enlarge playback images from the Menu (page 84).

- 1 Display the image you want to enlarge, then press the center of the control wheel to confirm [Enlarge].
- 2 Adjust the scaling by turning the control wheel.
- 3 Select the portion you want to enlarge by pressing the top/bottom/right/left of the control wheel.
- 4 To cancel the enlarged playback, press [Exit].

## Notes

- You cannot use the enlarged playback function with movies.
- To enlarge panoramic images, pause the playback first, and then press [Enlarge].

### Scaling range

The scaling range is as follows.

Image size	Scaling range
L	Approx. $\times 1.1 - \times 13$
M	Approx. $\times 1.1 - \times 10$
S	Approx. $\times 1.1 - \times 6.7$

# Deleting images

You can delete the image displayed.

- 1 Display the image you want to delete, and press [Delete].
- 2 Press the center of the control wheel to confirm [OK].  
Press [Cancel] to quit the operation.

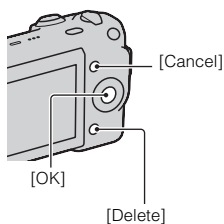

## Note

- You cannot delete protected images.

### To delete several images

Select [Menu] → [Playback] → [Delete] to select and delete specific images at the same time.

# DISP (Display Contents)



## Using the control wheel:

- 1 Press DISP (Display Contents) on the control wheel repeatedly to select the desired mode.



## Using the Menu:

- 1 During shooting, [Menu] → [Camera] → [Display Contents].  
During playback, [Menu] → [Playback] → [Display Contents].
- 2 Select the desired mode by turning the control wheel.

## During shooting

✓	<b>Disp. Basic Info</b>	Shows basic shooting information. Graphically shows the shutter speed and aperture value, except for when [Shoot Mode] is set to [Intelligent Auto] or [Sweep Panorama].	
	<b>Display Info.</b>	Shows recording information.	
	<b>No Disp. Info.</b>	Does not show recording information.	

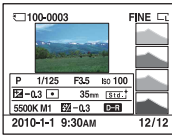
## During playback

✓	<b>Display Info.</b>	Shows recording information.	
	<b>Histogram</b>	Displays the luminance distribution graphically, in addition to recording information.	
	<b>No Disp. Info.</b>	Does not show recording information.	

### Note

- Histogram is not displayed during following playback modes.
  - Movie
  - Panorama
  - Slide Show

### 💡 What is histogram ?

The histogram displays the luminance distribution that shows how many pixels of a particular brightness exist in the picture. Brighter image will make the entire histogram shift to the right side, and darker image to the left side.

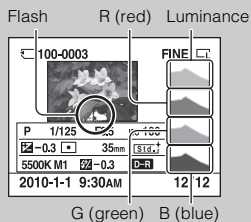

- If the image has a high-key or low-key portion, that portion flashes on the histogram display during playback (Luminance limit warning).

Table of contents

Sample photo search

Menu search



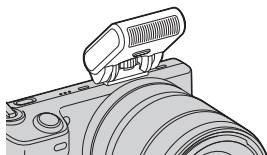

Index

# Flash Mode

In a dark location, using the flash allows you to shoot the subject brightly, and it also helps to prevent camera shake. When shooting into the sun, you can use the flash to shoot a bright image of the backlit subject.



- 1 Attach the flash.
- 2  (Flash Mode) on the control wheel → desired mode.  
Or, [Menu] → [Camera] → [Flash Mode] → desired mode.
- 3 Raise the flash when using the flash.

 <b>(Flash Off)</b>	Does not fire even if the flash is raised.
 <b>(Autoflash)</b>	Fires if it is dark or against light.
 <b>(Fill-flash)</b>	Fires every time you trigger the shutter.
 <b>(Slow Sync.)</b>	Fires every time you trigger the shutter. Slow sync shooting allows you to shoot a clear image of both the subject and the background by slowing the shutter speed.
 <b>(Rear Sync.)</b>	Fires right before the exposure is completed every time you trigger the shutter. Rear sync shooting allows you to shoot a natural image of the trail of a moving subject such as a moving bicycle or a walking person.

## Notes

- The default setting depends on the shooting mode.
- Available flash mode depends on the shooting mode.
- You cannot use the flash when recording movies.

## Tips on shooting with the flash

- The lens hood may block the light of the flash. Remove the lens hood when using the flash.
- When using the flash, shoot the subject at a distance of 1 m (3.3 feet) or greater.
- When shooting a backlit subject, select [Fill-flash]. The flash will operate even in bright daylight, and make faces come out brighter.

# Exposure Comp.

You can adjust the exposure in 1/3 EV steps in a range of -2.0 EV to +2.0 EV.

- 1  (Exposure Comp.) on the control wheel → desired value.  
Or, [Menu] → [Brightness/Color] → [Exposure Comp.] → desired value.

## Notes

- You cannot use [Exposure Comp.] when using the following functions:
  - [Intelligent Auto]
  - [Scene Selection]
  - [Manual Exposure]
- If you shoot a subject in extremely bright or dark conditions, or when you use the flash, you may not be able to get a satisfactory effect.

## Adjusting the exposure for better looking images



Overexposure = too much light  
Whitish image



Set [Exposure Comp.] toward -.



Correct exposure



Set [Exposure Comp.] toward +.



Underexposure = too little light  
Darker image

- To shoot subjects in brighter tones, set a +-side exposure compensation.  
To make photos of food look more appealing, shoot the food a little brighter than usual and try to use a white background.
- When shooting a blue sky, setting a --side exposure compensation will allow you to capture the sky in vivid colors.

# Drive Mode

You can set the drive mode, such as continuous, self-timer, or bracket shooting.

- 1 / (Drive Mode) on the control wheel → desired mode.  
Or, [Menu] → [Camera] → [Drive Mode] → desired mode.



	<b>(Single-shot Adv.)</b>	Shoots one still image. Normal shooting mode.
	<b>(Continuous Adv.)</b>	Shoots images continuously while you press and hold down the shutter button (page 34).
	<b>(Speed Priority Cont.)</b>	Shoots images continuously at high speed while you press and hold down the shutter button (page 35). Focus and brightness settings of the first shot are used for the following shots.
	<b>(Self-timer)</b>	Shoots an image after ten or two seconds (page 36).
	<b>(Self-timer(Cont.))</b>	Shoots images continuously after ten seconds (page 37).
	<b>(Bracket: Cont.)</b>	Shoots three images, each with different degrees of exposure (page 38).
	<b>(Remote Cdr.) (NEX-5/5C)</b>	Allows you to use the RMT-DSLR1 Wireless Remote Commander (sold separately) (page 39).

## Note

- You cannot change the setting when using the following functions:
  - [Hand-held Twilight] in [Scene Selection]
  - [Anti Motion Blur]
  - [Sweep Panorama]
  - [Auto HDR]

# Continuous Adv.

Shoots images continuously while you press and hold down the shutter button.



- 1  /  (Drive Mode) on the control wheel → [Continuous Adv.].  
Or, [Menu] → [Camera] → [Drive Mode] → [Continuous Adv.].

## Note

- You cannot use [Continuous Adv.] with the following functions:
  - [Scene Selection], excluding [Sports Action]
  - [Anti Motion Blur]
  - [Sweep Panorama]
  - [Smile Shutter]
  - [Auto HDR]

# Speed Priority Cont.



Shoots images continuously while you press and hold down the shutter button, at a higher speed than that of [Continuous Adv.].





- 1  /  (Drive Mode) on the control wheel → [Speed Priority Cont.].  
Or, [Menu] → [Camera] → [Drive Mode] → [Speed Priority Cont.].

## Notes

- You cannot use [Speed Priority Cont.] with the following functions.
  - [Scene Selection], excluding [Sports Action]
  - [Anti Motion Blur]
  - [Sweep Panorama]
  - [Smile Shutter]
  - [Auto HDR]
- Focus and brightness settings of the first shot are used for the following shots.

# Self-timer

- 1  /  (Drive Mode) on the control wheel → [Self-timer].  
Or, [Menu] → [Camera] → [Drive Mode] → [Self-timer].
- 2 [Option] → desired mode.

✓	 <b>(Self-timer: 10 Sec)</b>	Sets the 10-second delay self-timer. When you press the shutter button, the self-timer lamp flashes and the audio signal sounds until the shutter operates. To cancel the timer, press  /  (Self-timer) on the control wheel.
	 <b>(Self-timer: 2 Sec)</b>	Sets the 2-second delay self-timer. This reduces the camera shake caused by pressing the shutter button.

## Note

- You cannot use [Self-timer] with the following functions:
  - [Hand-held Twilight] in [Scene Selection]
  - [Anti Motion Blur]
  - [Sweep Panorama]
  - [Smile Shutter]
  - [Auto HDR]



# Self-timer(Cont.)

Continuously shoots the number of images you have set after ten seconds. You can choose the best shot from several shots taken.

1  /  (Drive Mode) on the control wheel → [Self-timer(Cont.)].

Or, [Menu] → [Camera] → [Drive Mode] → [Self-timer(Cont.)].

2 [Option] → desired mode.

✓	☺c3 <b>(Self-timer(Cont.): 10 Sec. 3 Img.)</b>	Shoots three or five still images continuously after ten seconds. When you press the shutter button, the self-timer lamp flashes and the audio signal sounds until the shutter operates. To cancel the timer, press  /  (Self-timer) on the control wheel.
	☺c5 <b>(Self-timer(Cont.): 10 Sec. 5 Img.)</b>	

## Note

- You cannot use [Self-timer(Cont.)] with the following functions:
  - [Hand-held Twilight] in [Scene Selection]
  - [Anti Motion Blur]
  - [Sweep Panorama]
  - [Smile Shutter]
  - [Auto HDR]

# Bracket: Cont.

Shoots three images while automatically shifting the exposure from base, to darker, then to lighter. Press and hold down the shutter button until the bracket recording is completed.

You can select an image that suits your intention, after recording.



1 / (Drive Mode) on the control wheel → [Bracket: Cont.].

Or, [Menu] → [Camera] → [Drive Mode] → [Bracket: Cont.].

2 [Option] → desired mode.



<input checked="" type="checkbox"/>	(Bracket: Cont.: 0.3 EV)	Images are taken with the set value of deviation (steps) from the base exposure.
<input type="checkbox"/>	(Bracket: Cont.: 0.7 EV)	

## Notes

- You cannot use [Bracket: Cont.] with the following functions:
  - [Hand-held Twilight] in [Scene Selection]
  - [Anti Motion Blur]
  - [Sweep Panorama]
  - [Smile Shutter]
  - [Auto HDR]
- The last shot is shown on the auto review.
- In [Manual Exposure], the exposure is shifted by adjusting the shutter speed.
- When you adjust the exposure, the exposure is shifted based on the compensated value.

# Remote Cdr. (NEX-5/5C)

You can shoot using the SHUTTER and 2SEC (the shutter is released after two seconds) buttons on the RMT-DSLR1 Wireless Remote Commander (sold separately). Also, refer to the operating instructions supplied with the Wireless Remote Commander.



- 1  /  (Drive Mode) on the control wheel → [Remote Cdr.]  
Or, [Menu] → [Camera] → [Drive Mode] → [Remote Cdr.].
- 2 Focus on the subject, point the transmitter of the Wireless Remote Commander to the remote sensor, and shoot the image.

## Notes

- You cannot use [Remote Cdr.] with the following functions:
  - Movie recording
  - [Hand-held Twilight] in [Scene Selection]
  - [Anti Motion Blur]
  - [Sweep Panorama]
  - [Auto HDR]
- A lens or hood may cover the remote sensor and prevent the sensor from receiving the light from the Remote Commander. Operate the Remote Commander from positions where the light to the remote sensor is not obscured.

# Image Index



Displays multiple images at the same time.

- 1 Press the  (Playback) button to switch to the playback mode.
- 2 Press  (Image Index) of the control wheel.  
Six-image index appears.  
You can switch to 12-image index; [Menu] → [Playback] → [Image Index].
- 3 To return to the single-image playback, select the desired image and press the center of the control wheel.

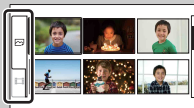

## Switching between the still image and movie



On the image index screen, you can switch the image type by selecting  (still image) or  (movie) on the left of the screen followed by pressing the center of the control wheel.

Still images and movies cannot be displayed on the same index.

# Intelligent Auto

The camera analyzes the subject, and allows you to shoot with appropriate settings.

1 [Menu] → [Shoot Mode] → [Intelligent Auto].

2 Point the camera to the subject.

When the camera recognizes the scene, the Scene Recognition icon and guide appear on the screen.

The camera recognizes 🌙 (Night View), 📵 (Tripod Night View), 🌃 (Night Portrait), 📷 (Backlight),

👤 (Backlight Portrait), 👤 (Portrait), 🏞️ (Landscape),

or 📷 (Macro).



Scene Recognition icon and guide

## Notes

- [Flash Mode] is set to [Autoflash] or [Flash Off].
- You can shoot even if the camera has not recognized the scene.
- When [Face Detection] is set to [Off], the [Portrait], [Backlight Portrait], and [Night Portrait] scenes are not recognized.

## 💡 Defocusing the background easily



During Intelligent Auto recording, you can defocus the background. Press the center of the control wheel and turn the control wheel.

When the Scene Recognition function is enabled, the camera analyzes the scene when you press the center of the control wheel, and uses it as the Recognized Scene.

 If you shoot a still image of a subject that is difficult to focus on



When the camera cannot focus on the subject automatically, the focus indicator blinks. Either recompose the shot or change the focus setting.

Focus indicator

Focus indicator	Status
● lit	Focus locked.
⦿ lit	Focus is confirmed. Focal point moves following a moving subject.
⦿ lit	Still focusing.
● flashing	Cannot focus.

- Focusing may be difficult in the following situations:
  - It is dark and the subject is distant.
  - The contrast between the subject and the background is poor.
  - The subject is seen through glass.
  - The subject is moving quickly.
  - The subject reflects light such as mirror, or has shiny surfaces.
  - The subject is flashing.
  - The subject is backlit.

Table of contents

Sample photo search

Menu search

Index

# Scene Selection

Allows you to shoot with preset settings according to the scene.

1 [Menu] → [Shoot Mode] → [Scene Selection] → desired mode.















 <b>(Portrait)</b>	Blurs away backgrounds and sharpens the subject. Expresses skin tones softly.	
 <b>(Landscape)</b>	Shoots the entire range of scenery in sharp focus with vivid colors.	
 <b>(Macro)</b>	Shoots close subjects such as flowers, insects, food, or small items.	
 <b>(Sports Action)</b>	Shoots a moving subject at a fast shutter speed so that the subject looks as if it is standing still. The camera shoots images continuously while the shutter button is pressed.	
 <b>(Sunset)</b>	Shoots the red of the sunset beautifully.	
 <b>(Night Portrait)</b>	Shoots portraits in night scenes. Attach and fire the flash.	
 <b>(Night View)</b>	Shoots night scenes without losing the dark atmosphere.	

Table of contents

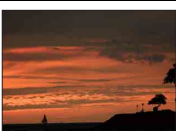
Sample photo search

Menu search

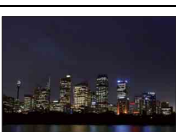
Index

 <b>(Hand-held Twilight)</b>	Shoots night scenes with less noise and blur without using a tripod. A burst of shots are taken, and image processing is applied to reduce subject blur, camera shake, and noise.	
---	---	--

## Notes

- In the [Night View] and [Night Portrait] modes, the shutter speed is slower, so using a tripod is recommended to prevent the image from blurring.
- In the [Hand-held Twilight] mode, the shutter clicks six times and an image is recorded.
- If you select [Hand-held Twilight] with [RAW] or [RAW & JPEG], the image quality becomes [Fine] temporarily.
- Reducing blur is less effective even in [Hand-held Twilight] when shooting:
  - Subjects with erratic movement
  - Subjects are too close to the camera
  - Subjects with a repeating pattern such as tiles, and subjects with little contrast such as sky, sandy beach, or lawn
  - Subjects with constant change such as waves or water falls
- In the case of [Hand-held Twilight], block noise may occur when using a light source that flickers, such as fluorescent lighting.
- The shortest focal distance does not change even if you select [Macro].

Table of contents

Sample photo search

Menu search

Index

# Anti Motion Blur

This is suitable for indoor shots without using the flash, to reduce the subject blur.

1 [Menu] → [Shoot Mode] → [Anti Motion Blur].

2 Shoot with the shutter button.

The camera combines six shots at high sensitivity into one still image, so camera shake is reduced while preventing noise.

## Notes

- If you select [Anti Motion Blur] with [RAW] or [RAW & JPEG], the image quality becomes [Fine] temporarily.
- The shutter clicks six times and an image is recorded.
- Reducing blur is less effective when shooting:
  - Subjects with erratic movement.
  - Subjects are too close to the camera.
  - Subjects with a repeating pattern such as tiles, and subjects with little contrast such as sky, sandy beach, or lawn.
  - Subjects with constant change such as waves or water falls.
- When using a light source that flickers, such as fluorescent lighting, block noise may occur.

# Sweep Panorama

Allows you to create a panoramic image from composed images.



- 1 [Menu] → [Shoot Mode] → [Sweep Panorama].
- 2 Point the camera at the edge of the subject, then press the shutter button fully down.



This part will not be taken.

- 3 Pan the camera to the end, following the guidance on the LCD monitor.



Guidance bar

## Notes

- If you cannot pan the camera across the entire subject within the given time, a gray area occurs in the composed image. If this happens, move the camera fast to record a full panoramic image.
- The camera continues shooting during [Sweep Panorama] recording, and the shutter keeps clicking until the end of the shooting.
- Since several images are stitched together, the stitched part will not be recorded smoothly.
- Under low light conditions, panoramic images may be blurred.
- Under lights that flicker such as fluorescent light, the brightness or color of the combined image is not always the same.
- When the whole angle of panoramic shooting and the angle in which you fixed the focus and exposure with AE/AF lock are extremely different in brightness, color and focus, the shooting will not be successful. If this happens, change the lock angle and shoot again.
- [Sweep Panorama] is not suitable when shooting:
  - Subjects are moving.
  - Subjects are too close to the camera.
  - Subjects with a repeating pattern such as tiles, and subjects with little contrast such as sky, sandy beach, or lawn.
  - Subjects with constant change such as waves or water falls.
  - Subjects with the sun or electric lights, etc. that are much brighter than surroundings.
- [Sweep Panorama] recording may be discontinued in the following situations:
  - You pan the camera too fast or too slow.
  - There is too much camera shake.

## 💡 Tips for shooting a panoramic image

Pan the camera in an arc with a constant velocity and in the same direction as the indication on the LCD monitor. [Sweep Panorama] is better suited for still subjects, rather than moving ones.

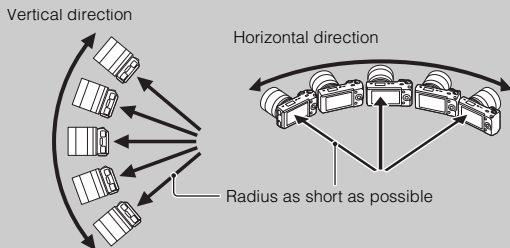

- When using a zoom lens, it is recommended to use it with W side.
- Determine the scene and press the shutter button halfway, so that you can lock the focus, exposure, and white balance.
- If a section with greatly varied shapes or scenery is concentrated along a screen edge, the image composition may fail. In such case, adjust the frame composition so that the section is in the center of the image, then shoot again.
- You can select the direction by [Menu] → [Camera] → [Panorama Direction], and the image size by [Menu] → [Image Size] → [Image Size].

## 💡 Playing back scrolling panoramic images

You can scroll panoramic images from the beginning to the end by pressing the center of the control wheel while panoramic images are being displayed. Press it again to pause.



Shows the displayed area of the whole panoramic image.

- Panoramic images are played back with the supplied software "PMB."
- Panoramic images shot with other cameras may not be displayed or scrolled correctly.

# Manual Exposure

You can shoot with the desired exposure setting by adjusting both the shutter speed and aperture.

1 [Menu] → [Shoot Mode] → [Manual Exposure].

2 Press the bottom of the control wheel repeatedly to select shutter speed or aperture.

Shutter speed and aperture adjustment screens appear alternately.

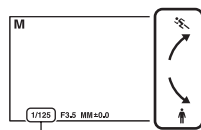

Shutter speed

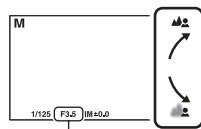

Aperture (F-value)

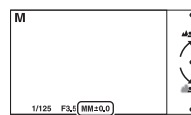

Metered manual

3 Turn the control wheel to select the desired value.

Check the exposure value at “MM” (metered manual).

Toward +: Images become brighter.

Toward -: Images become darker.

0: Appropriate exposure analyzed by the camera

4 Adjust the focus and shoot the subject.

## Notes

- You cannot select [Flash Off] and [Autoflash] in [Flash Mode].
- The  (Camera shake warning) indicator is not indicated in manual exposure mode.
- The ISO setting [ISO AUTO] is set to [ISO 200] in manual exposure mode. Set the ISO sensitivity as necessary.
- The brightness of the image on the LCD monitor may differ from the actual image being shot.

## BULB

You can shoot trails with long exposure. BULB is suitable for shooting trails of light, such as fireworks.



- 1 [Menu] → [Shoot Mode] → [Manual Exposure].
- 2 Press the bottom of the control wheel to select shutter speed.
- 3 Turn the control wheel to the left until [BULB] is indicated.

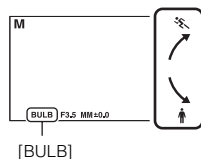



- 4 Press the shutter button halfway down to adjust the focus.
- 5 Press and hold the shutter button for the duration of the shooting.  
As long as the shutter button is pressed, the shutter remains open.

### Notes

- Since the shutter speed becomes slow and the camera shake tends to occur more easily, it is recommended that you use a tripod.
- The longer the exposure time, the more conspicuous the noise on the image.
- After shooting, noise reduction (Long Exposure NR) will be done for the same amount of time that the shutter was open. You cannot do any further shooting during the reduction.
- When the [Smile Shutter] or [Auto HDR] function is activated, you cannot set the shutter speed to [BULB].
- If the [Smile Shutter] or [Auto HDR] function is used with the shutter speed set to [BULB], the shutter speed is temporarily set to 30 seconds.

### 🔦 Using the Remote Commander (NEX-5/5C)

Pressing the SHUTTER button on the Wireless Remote Commander triggers BULB shooting and pressing it again stops BULB shooting. You do not need to press and hold the SHUTTER button on the Wireless Remote Commander.

To use the Wireless Remote Commander, press  /  (Drive Mode) on the control wheel, and select [Remote Cdr.] → [On].

# Shutter Priority

You can express the movement of a moving subject in various way by adjusting the shutter speed, for example, at the instant of the movement with high speed shutter, or as a trailing image with low speed shutter.

1 [Menu] → [Shoot Mode] → [Shutter Priority]  
→ desired value.

2 Adjust the focus and shoot the subject.

The aperture is automatically adjusted to obtain proper exposure.

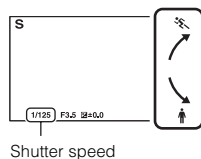

## Notes

- You cannot select [Flash Off] and [Autoflash] in [Flash Mode].
- The  (Camera shake warning) indicator is not indicated in shutter speed priority mode.
- When the shutter speed is one second or more, noise reduction (Long Exposure NR) will be done after shooting. You cannot do any further shooting during the reduction.
- If proper exposure cannot be obtained after the setup, when you press the shutter button halfway down, the aperture value blinks. Although you can shoot as it is, resetting is recommended.
- The brightness of the image on the LCD monitor may differ from the actual image being shot.

## Shutter speed



When a faster shutter speed is used, a moving subject such as a running person, cars, and sea spray appears as if they are stopped.



When a slower shutter speed is used, a trailing image of the movement of the subject is captured to make more natural and dynamic image.

# Aperture Priority

Blurs or sharpens things in front of and beyond the subject.

1 [Menu] → [Shoot Mode] → [Aperture Priority] → desired value.

- Smaller F-value: The subject is in focus, but things in front of and beyond the subject is blurred.
- Larger F-value: The subject and its foreground and background are all in focus.

2 Adjust the focus and shoot the subject.

The shutter speed is automatically adjusted to obtain proper exposure.

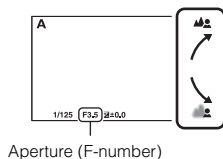

## Notes

- You cannot select [Flash Off] and [Autoflash] in [Flash Mode].
- If proper exposure cannot be obtained after the setup, when you press the shutter button halfway down, the shutter speed blinks. Although you can shoot as it is, resetting is recommended.
- The brightness of the image on the LCD monitor may differ from the actual image being shot.

## Aperture

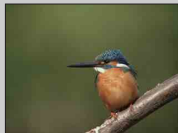

Smaller F-value (opening the aperture) narrows the range that is in focus. This allows you to put the subject in sharp focus and blur things in front of and beyond the subject. (Depth of field becomes shallower.)



Larger F-value (narrowing down the aperture) widens the range that is in focus. This allows you to shoot the depth of the scenery. (Depth of field becomes deeper.)

# Program Auto

While exposure is adjusted by the camera automatically, you can set shooting functions such as ISO sensitivity, Creative Style, D-Range optimizer.

- 1 [Menu] → [Shoot Mode] → [Program Auto].
- 2 Set the shooting functions to your desired settings.
- 3 Adjust the focus and shoot the subject.

## Note

- You cannot select [Flash Off] and [Autoflash] in [Flash Mode].

# AF/MF Select

Selects auto focusing or manual focusing.

1 [Menu] → [Camera] → [AF/MF Select] → desired mode.

✓	<b>AF (Autofocus)</b>	Focuses automatically.
	<b>DMF (DMF)</b>	After focusing automatically, make fine focus adjustment manually (Direct Manual Focus).
	<b>MF (Manuafocus)</b>	Adjusts the focus manually. Turn the focusing ring right or left to make the subject look clearer.

## Note

- If you turn the focusing ring when [Manuafocus] or [DMF] is selected, the image is enlarged automatically to enable you to check focus area easier. You can prevent the image from being enlarged by selecting [Menu] → [Setup] → [MF Assist] → [Off].

## 💡 Using manual focusing effectively



“Focus fixing” is convenient when you can predict the distance to the subject. With “Focus fixing,” you can fix the focus in advance to the distance at which the subject is to pass.

## 💡 To measure the exact distance to the subject

The ⊖ mark shows the location of the image sensor\*. When you measure the exact distance between the camera and the subject, refer to the position of the horizontal line. The distance from the lens contact surface to the image sensor is about 18 mm (23/32 in.).

\* The image sensor is the part of the camera that acts as the film.

- If the subject is closer than the minimum shooting distance of the attached lens, the focus cannot be confirmed. Make sure you put enough distance between the subject and the camera.

NEX-5/5C

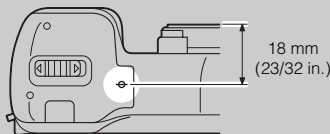

Bottom

NEX-3

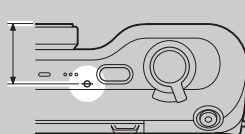

Top

## DMF (Direct Manual Focus)

- 1 [Menu] → [Camera] → [AF/MF Select] → [DMF].
- 2 Press the shutter button halfway down to focus automatically.
- 3 Keep the shutter button halfway down, rotate the focusing ring of the lens to achieve a sharp focus.





### Note

- [Autofocus Mode] is fixed to [Single-shot AF].

# Autofocus Area

Selects the focusing area. Use this function when it is difficult to get the proper focus in auto focus mode.

1 [Menu] → [Camera] → [Autofocus Area] → desired mode.

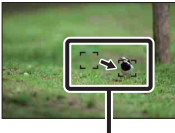
✓	 <b>(Multi)</b>	<p>The camera determines which of the 25 AF areas is used for focusing.</p> <p>When you press the shutter button halfway down in still image shooting mode, a green frame is displayed around the area that is in focus.</p> <ul style="list-style-type: none"><li>• When the Face Detection function is active, AF operates with priority on faces.</li></ul>	 <p>AF range finder frame</p>
	 <b>(Center)</b>	<p>The camera uses the AF area located in the center area exclusively.</p>	 <p>AF range finder frame</p>
	 <b>(Flexible Spot)</b>	<p>Moves the focusing area to focus on a small subject or narrow area by pressing the top/bottom/right/left of the control wheel.</p>	 <p>AF range finder frame</p>

## Notes

- When this function is set to other than [Multi], you cannot use the [Face Detection] function.
- [Multi] is selected when using the following functions:
  - Movie recording
  - [Intelligent Auto]
  - [Scene Selection]
  - [Anti Motion Blur]
  - [Sweep Panorama]
  - [Smile Shutter]

# Autofocus Mode

Selects the focus method to suit the movement of the subject.

1 [Menu] → [Camera] → [Autofocus Mode] → desired mode.

✓	<b>AF-S (Single-shot AF)</b>	The camera focuses and the focus is locked when you press the shutter button halfway down. Use this when the subject is motionless.
	<b>AF-C (Continuous AF)</b>	The camera continues to focus while the shutter button is pressed and held halfway down. Use this when the subject is in motion.

## Notes

- [Single-shot AF] is selected when using the following functions:
  - [Intelligent Auto]
  - [Self-timer]
  - [Remote Cdr.]
  - [Scene Selection], excluding [Sports Action]
  - [Anti Motion Blur]
  - [Sweep Panorama]
  - [Smile Shutter]
- [Continuous AF] is selected when the exposure mode is set to [Sports Action] in [Scene Selection].
- In [Continuous AF] mode, the audio signals will not sound when the subject is in focus.

# Precision Dig. Zoom

When a single focus lens is attached, you can shoot still images while zooming in on the center portion.

- 1 Attach a single focus lens.
- 2 [Menu] → [Camera] → [Precision Dig. Zoom].
- 3 Turn the control wheel and decide the zoom rate.  
You can zoom in up to ten times.
- 4 To stop zooming, press [Exit].

## Notes

- You can use this item only when a single focus lens is attached.
- You cannot set this item when using the following functions:
  - [Hand-held Twilight] in [Scene Selection]
  - [Anti Motion Blur]
  - [Sweep Panorama]
  - [Smile Shutter]
  - [RAW] or [RAW & JPEG] in [Quality]
- If you press the MOVIE button when [Precision Dig. Zoom] is working, zooming is canceled, the image on the screen returns to the normal size, and movie recording starts.
- As the image is zoomed by digital processing, the image quality deteriorates compared to that before zooming was used.

# Face Detection

Detects the faces of your subjects and adjusts the focus, flash, exposure, and white balance settings automatically. You can select the priority face to be focused on.

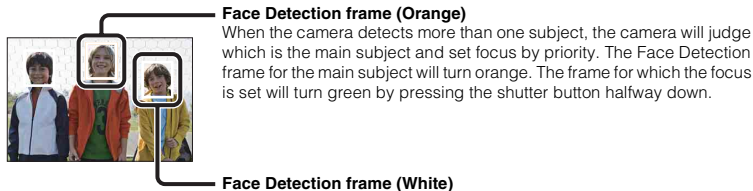

1 [Menu] → [Camera] → [Face Detection] → desired mode.

	<b>(Off)</b>	Does not use the Face Detection function.
✓	<b>(Auto)</b>	Selects the face which the camera is to automatically focus on.
	<b>(Child Priority)</b>	Detects and shoots with priority on child's face.
	<b>(Adult Priority)</b>	Detects and shoots with priority on adult's face.

## Notes

- You cannot use [Face Detection] with the following functions:
  - Movie recording
  - [Sweep Panorama]
  - [Manualfocus]
  - [Precision Dig. Zoom].
- You can select [Face Detection] only when [Autofocus Area] is set to [Multi], and [Metering Mode] is also set to [Multi].
- Up to eight faces of your subjects can be detected.
- Adults and children may not be recognized correctly depending on the conditions.
- During [Smile Shutter] shooting, [Face Detection] is automatically set to [Auto] even if it is set to [Off].

# Smile Shutter

When the camera detects a smile, the shutter is released automatically.

1 [Menu] → [Camera] → [Smile Shutter] → [On].

2 Wait for a smile to be detected.

When the smile level exceeds the ◀ point on the indicator, the camera records images automatically.

If you press the shutter button during Smile Shutter shooting, the camera shoots the image, then returns to Smile Shutter mode.

3 To exit Smile Shutter mode, [Menu] → [Camera] → [Smile Shutter] → [Off].

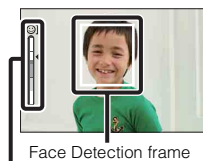

Smile Detection indicator

## Notes

- You cannot use [Smile Shutter] with the following functions:
  - [Hand-held Twilight] in [Scene Selection]
  - [Anti Motion Blur]
  - [Sweep Panorama]
  - [Manualfocus]
  - [Precision Dig. Zoom]
- Unless the subject is in focus, the shutter is not released, even if the smile level exceeds the ◀ point. Adjust the composition or brightness to enable the camera to focus easily.
- Shooting using the Smile Shutter ends automatically when the memory card becomes full.
- Smiles may not be detected correctly depending on the conditions.
- The drive mode turns to [Single-shot Adv.] or [Remote Cdr.] automatically.

## 💡 Tips for better capturing of smiles





- ① Do not cover the eyes with the bangs.  
Do not obscure the face by a hat, masks, sunglasses, etc.
- ② Try to orient the face in front of the camera and be as level as possible.  
Keep the eyes narrowed.
- ③ Give a clear smile with an open mouth.  
The smile is easier to be detected when the teeth are shown.

- The shutter operates when any person whose smile is detected.
- If a smile is not detected, set the [Smile Detection] in the menu.

# Smile Detection

Sets the sensitivity of the Smile Shutter function for detecting smiles.

1 [Menu] → [Camera] → [Smile Detection] → desired mode.

	 <b>(Big Smile)</b>	Detects a big smile.
✓	 <b>(Normal Smile)</b>	Detects a normal smile.
	 <b>(Slight Smile)</b>	Detects even a slight smile.

## Notes

- You cannot change [Smile Detection] when using the following functions:
  - [Hand-held Twilight] in [Scene Selection]
  - [Anti Motion Blur]
  - [Sweep Panorama]
  - [Manualfocus]
- Smiles may not be detected correctly depending on the conditions.

# Panorama Direction

Sets the direction to pan the camera when you shoot Sweep Panorama images.

1 [Menu] → [Camera] → [Panorama Direction] → desired mode.





✓	 <b>(Right)</b>	Pan the camera in the direction you set.
	 <b>(Left)</b>	
	 <b>(Up)</b>	
	 <b>(Down)</b>	

Table of contents

Sample photo search

Menu search

Index

# Shooting Tip List

Allows you to search through all shooting tips in the camera.

Use this item when you want to look at shooting tips you have seen before.

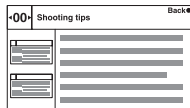

- 1 [Menu] → [Camera] → [Shooting Tip List].
- 2 Press the left or right of the control wheel and search for the desired shooting tip.  
Turn the control wheel to scroll the text up and down.







# Image Size

The image size determines the size of the image file that is recorded when you record an image.

The larger the image size, the more detail will be reproduced when the image is printed on large-format paper. The smaller the image size, the more images can be recorded.

1 [Menu] → [Image Size] → [Image Size] → desired mode.

## Still



Image size when [Aspect Ratio] is 3:2		Usage guidelines	
✓	 (L: 14M)	4592 × 3056 pixels	For prints up to A3+ size
	 (M: 7.4M)	3344 × 2224 pixels	For prints up to A4 size
	 (S: 3.5M)	2288 × 1520 pixels	For prints L/2L size
Image size when [Aspect Ratio] is 16:9		Usage guidelines	
✓	 (L: 12M)	4592 × 2576 pixels	For viewing on a high-definition TV
	 (M: 6.3M)	3344 × 1872 pixels	
	 (S: 2.9M)	2288 × 1280 pixels	

### Notes

- When you print still images recorded with 16:9 aspect ratio, both edges may be cut off.
- When you select a RAW image with [Quality], the image size corresponds to L.

## Panorama

The image size varies depending on the [Panorama Direction] setting.

✓	 (Standard)	Shoots images using standard size. Vertical: 2160 × 3872 Horizontal: 8192 × 1856
	 (Wide)	Shoots images using wide size. Vertical: 2160 × 5536 Horizontal: 12416 × 1856



### Note

- When you print panoramic images, both edges may be cut off.

## Movie

The larger the image size, the higher the image quality.

### NEX-5/5C

Image size in [AVCHD] mode		Average bit-rate	Usage guidelines
	<b>1080 (1920 × 1080)</b>	17 Mbps	Records with the highest image quality for viewing on a high-definition TV.
Image size in [MP4] mode		Average bit-rate	Usage guidelines
✓	 <b>1080 (1440 × 1080)</b>	12 Mbps	Records with high image quality for viewing on a high-definition TV.
	 <b>VGA (VGA) (640 × 480)</b>	3 Mbps	Records in the suitable size for WEB uploads.

### NEX-3

Image size		Average bit-rate	Usage guidelines
✓	<b>1280 × 720 (Fine)</b>	9 Mbps	Records with high image quality for viewing on a high-definition TV.
	<b>1280 × 720 (Standard)</b>	6 Mbps	
	<b>VGA (640 × 480)</b>	3 Mbps	Records in the suitable size for WEB uploads.

#### Note

- A telephoto image results except when the [VGA] image size is selected for movies.

# Aspect Ratio

Sets the aspect ratio of still images.

1 [Menu] → [Image Size] → [Aspect Ratio] → desired mode.

✓	<b>3:2</b>	Standard aspect ratio. Suitable for prints.
	<b>16:9</b>	For viewing on a high-definition TV.

## Note

- You cannot select [Aspect Ratio] when using [Sweep Panorama].

# Quality

Selects the compression format of still images.

1 [Menu] → [Image Size] → [Quality] → desired mode.

	<b>RAW (RAW)</b>	File format: RAW (Records using the RAW compression format.) This format does not allow you to perform any digital processing on the images. Select this format to process images on a computer for professional purposes. <ul style="list-style-type: none"><li>• The image size is fixed to the maximum size. The image size is not displayed on the LCD monitor.</li></ul>
	<b>RAW+J (RAW &amp; JPEG)</b>	File format: RAW (Records using the RAW compression format.) + JPEG A RAW image and a JPEG image are created at the same time. This is suitable when you need two image files, a JPEG for viewing, and a RAW for editing. <ul style="list-style-type: none"><li>• The image quality is fixed to [Fine] and the image size is fixed to [L].</li></ul>
✓	<b>FINE (Fine)</b>	File format: JPEG
	<b>STD (Standard)</b>	The image is compressed in the JPEG format when recorded. Since the compression rate of [Standard] is higher than that of [Fine], the file size of [Standard] is smaller than that of [Fine]. This will allow more files to be recorded on one memory card, but the image quality will be lower.

## Notes

- You cannot select the image quality when using [Sweep Panorama].
- You cannot add DPOF (print order) registration to RAW format images.
- You cannot use [Auto HDR] with [RAW] and [RAW & JPEG] images.

## RAW images

The RAW format file is the raw data yet to go through any kind of digital processing. A RAW file is different from a more common file format such as JPEG in that it is the raw material to be processed for professional purposes.

You need the “Image Data Converter SR” software included on the CD-ROM (supplied) in order to open a RAW image recorded on this camera. With this software, a RAW image can be opened and converted to a common format, such as JPEG or TIFF, and its white balance, color saturation, contrast, etc., can be readjusted.

# File Format (NEX-5/5C)

Selects the movie file format.

1 [Menu] → [Image Size] → [File Format] → desired mode.

✓	<b>AVCHD</b>	This file format is suitable for viewing smooth video images on a high-definition TV. Movies shot with this camera are recorded in AVCHD format, approximately 60 fields/sec (1080 60i-compatible devices) or 50 fields/sec (1080 50i-compatible devices), in interlace mode, with Dolby Digital audio, AVCHD format.
	<b>MP4</b>	This file format is suitable for WEB uploads, e-mail attachments or playing back on computers. Movies shot with this camera are recorded in MPEG-4 format at approximately 30 frames/sec (1080 60i-compatible devices) or approximately 25 frames/sec (1080 50i-compatible devices), in progressive mode, with AAC audio, mp4 format.

## Checking 60i or 50i

To check if your camera is a 1080 60i-compatible device or 1080 50i-compatible device, check for the following marks on the bottom of the camera.

1080 60i-compatible device: 60i

1080 50i-compatible device: 50i

## Playing movies on other devices

This camera uses MPEG-4 AVC/H.264 High Profile for AVCHD format recording.

Movies recorded in AVCHD format with this camera cannot be played by the following devices.

- Other AVCHD format compatible devices which are not compatible with High Profile
- Devices which are not compatible with the AVCHD format

This camera also uses MPEG-4 AVC/H.264 Main Profile for MP4 format recording.

For this reason, movies recorded in MP4 format with this camera cannot be played on devices other than those that support MPEG-4 AVC/H.264.

# ISO

Sets the luminous sensitivity.

1 [Menu] → [Brightness/Color] → [ISO] → desired setting.

✓	<b>ISO AUTO (ISO AUTO)</b>	Sets the ISO sensitivity automatically.
	<b>200/400/800/1600/ 3200/6400/12800</b>	You can set a faster shutter speed, and reduce image blur in dark locations or of moving subjects by increasing ISO sensitivity (select a larger number).

## Notes

- [ISO AUTO] is selected when using the following functions:
  - [Intelligent Auto]
  - [Scene Selection]
  - [Anti Motion Blur]
  - [Sweep Panorama]
- The larger the number, the higher the noise level.
- When the exposure mode is set to [Program Auto], [Aperture Priority], [Shutter Priority], and [ISO] is set to [ISO AUTO], ISO is automatically set between ISO 200 and 1600.
- The [ISO AUTO] setting is not provided in [Manual Exposure]. If you change the exposure mode to [Manual Exposure] with the [ISO AUTO] setting, it is switched to 200. Set the ISO according to your shooting conditions.

## 💡 Adjusting ISO Sensitivity (Recommended Exposure Index)

ISO setting (speed) is the sensitivity to light of recording media that incorporates an image sensor that receives light. Even when the exposure is the same, images differ depending on the ISO setting.



### High ISO sensitivity

With high ISO sensitivity, images will be captured with an appropriate brightness even under insufficient exposure. However, increasing ISO sensitivity will cause images to become noisy.



### Low ISO sensitivity

You can record smooth images. However, compensation for low ISO sensitivity will be made by slowing down the shutter speed. You should take camera shake or movement of subjects into account, too.









# White Balance

Adjusts the color tones according to the ambient light conditions.

Use this feature when the color tone of the image did not come out as you expected, or when you want to change the color tone on purpose for photographic expression.

1 [Menu] → [Brightness/Color] → [White Balance] → desired mode.

To adjust the white balance to suit a specific light source, see the explanation on each mode.

✓	<b>AWB (Auto WB)</b>	The camera automatically detects a light source and adjusts the color tones.
	 <b>(Daylight)</b>	If you select an option to suit a specific light source, the color tones are adjusted for the light source (preset white balance).
	 <b>(Shade)</b>	
	 <b>(Cloudy)</b>	
	 <b>(Incandescent)</b>	
	 <b>(Fluorescent)</b>	
	 <b>(Flash)</b>	
	 <b>(C.Temp./Filter)</b>	Adjusts the white balance depending on the light source (color temperature). Achieves the effect of CC (Color Compensation) filters for photography.
	 <b>(Custom)</b>	Allows to use the white balance setting retained by [Custom Setup].
	 <b>SET (Custom Setup)</b>	Memorizes the basic white color (Custom white balance).





## Note

- [Auto WB] is selected when using the following functions:
  - [Intelligent Auto]
  - [Scene Selection]

## Effects of lighting conditions

The apparent color of the subject is affected by the lighting conditions.

The color tones are adjusted automatically, but you can adjust color tones manually using the [White Balance] function.

Weather/lighting	Daylight	Cloudy	Fluorescent	Incandescent
Characteristics of light	White (standard)	Bluish	Green-tinged	Reddish
				

## Preset white balance (☀️ 🏠 👤 🔦 🌞 WB ⚡)

- 1 [Menu] → [Brightness/Color] → [White Balance] → desired mode.
- 2 As necessary, [Option] → adjust the color tone.  
Adjusting it toward + turns the image reddish and adjusting it toward – turns the image bluish.

## C.Temp./Filter

- 1 [Menu] → [Brightness/Color] → [White Balance] → [C.Temp./Filter].
- 2 [Option] → desired value.

<b>Color Temp.</b>	The higher the number, the more reddish the image, and the lower the number, the more bluish the image. (The default setting is 5500 K.)
<b>Color Filter</b>	Based on using the set color temperature as the standard, the color can be compensated to G (Green) or M (Magenta). The higher the number, the more the color is compensated. (The default setting is 0.)

## Custom white balance

- 1 [Menu] → [Brightness/Color] → [White Balance] → [Custom Setup].
- 2 Hold the camera so that the white area fully covers the AF area located in the center, and then press the shutter button down.  
The shutter clicks and the calibrated values (color temperature and color filter) are displayed.
- 3 To call the custom white balance setting, [Menu] → [Brightness/Color] → [White Balance] → [Custom].





### Note

- If the flash is used when the shutter button is pressed, a custom white balance is registered with the flash light taken into account. Take pictures with the flash in later shootings.

# Metering Mode

Selects the metering mode that sets which part of the subject to measure to determine the exposure.

1 [Menu] → [Brightness/Color] → [Metering Mode] → desired mode.

✓	 <b>(Multi)</b>	Measures light on each area after dividing the total area into multiple areas and determines the proper exposure of the entire screen (Multi-pattern metering).
	 <b>(Center)</b>	Measures the average brightness of the entire screen, while emphasizing the central area of the screen (Center-weighted metering).
	 <b>(Spot)</b>	Measures only the central area (Spot metering). This function is useful when the subject is backlit or when there is strong contrast between the subject and the background.  Spot metering cross hairs position on the subject.

## Notes

- If you set [Metering Mode] to other than [Multi], the [Face Detection] function cannot be used.
- [Multi] is selected when using the following functions:
  - Movie recording
  - [Intelligent Auto]
  - [Scene Selection]
  - [Precision Dig. Zoom]
  - [Smile Shutter]

# Flash Compensation

Adjusts the amount of flash light in 1/3 EV steps in a range of -2.0 EV to +2.0 EV. Flash compensation changes the amount of flash light only. Exposure compensation changes the amount of flash light along with the change of the shutter speed and aperture.

1 [Menu] → [Brightness/Color] → [Flash Compensation] → desired value.

Selecting higher values (+ side) makes the flash level higher and images brighter. Selecting lower values (- side) makes the flash level lower and images darker.

## Notes

- You cannot use [Flash Compensation] with the following functions:
  - [Intelligent Auto]
  - [Scene Selection]
  - [Anti Motion Blur]
  - [Sweep Panorama]
  - when no flash is attached
- The higher flash effect may not be visible due to the limited amount of flash light available, if the subject is outside the maximum range of the flash. If the subject is very close, the lower flash effect may not be visible.

## 💡 Tips to adjust the brightness when shooting people

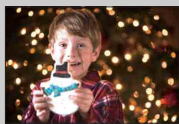



- It is important to balance the brightness of people against the dark background in night portraits. You can adjust the brightness of people near the camera by changing the flash light intensity.
- If the subject is too far for the flash and still too dark after adjustment, move closer to your subject.

# DRO/Auto HDR

Corrects the brightness or contrast.

1 [Menu] → [Brightness/Color] → [DRO/Auto HDR] → desired mode.

	 <b>(Off)</b>	Does not use [DRO/Auto HDR].
✓	 <b>(D-Range Opt.)</b>	By dividing the image into small areas, the camera analyzes the contrast of light and shadow between the subject and the background, producing the image with the optimal brightness and gradation.
	 <b>(Auto HDR)</b>	Shoots three images with different exposures, and then overlays the bright area of the under exposed image and the dark area of the over exposed image to create an image with rich gradation. One image with proper exposure and one overlaid image are recorded.

## Note

- You can select [DRO/Auto HDR] only in the following modes:
  - [Manual Exposure]
  - [Shutter Priority]
  - [Aperture Priority]
  - [Program Auto]

## D-Range Opt.

Corrects the brightness of the image (DRO: Dynamic Range Optimizer).

1 [Menu] → [Brightness/Color] → [DRO/Auto HDR] → [D-Range Opt.].

2 [Option] → desired value.

✓	 <b>(Auto)</b>	Corrects the brightness automatically.
	<b>Lv1 – Lv5</b>	Optimizes the gradations of a recorded image in each area of the image. Select the optimal level between Lv1 (weak) and Lv5 (strong).

## Notes

- [Auto] is selected when using the following functions:
  - [Intelligent Auto]
  - [Portrait], [Landscape], [Macro], [Sports Action] in [Scene Selection]
- When shooting with the D-Range optimizer, the image may be noisy. Select the proper level by checking the recorded image, especially when you enhance the effect.

## Auto HDR

Widens the range (gradations) so that you can record from bright parts to dark parts in correct brightness (Auto High Dynamic Range). One image with proper exposure and one overlaid image are recorded.

- 1 [Menu] → [Brightness/Color] → [DRO/Auto HDR] → [Auto HDR].
- 2 [Option] → desired value.

✓	 (Auto Exposure Diff.)	Corrects the exposure difference automatically.
	<b>1.0 EV – 6.0 EV</b>	Sets the exposure difference, based on the contrast of the subject. Select the optimal level between 1.0 EV (weak) and 6.0 EV (strong).

### Notes







- You cannot start the next shoot until the capture process is completed after you shoot.
- You cannot use this function with [RAW] and [RAW & JPEG] images.
- You cannot select [Auto HDR] during [Smile Shutter]. If you turn on the [Smile Shutter] function with [Auto HDR] selected, the camera will temporarily use the DRO setting.
- Since the shutter is released three times for one shot, be careful about the following:
  - Use this function when the subject is motionless or does not blink.
  - Do not recompose.
- You may not obtain a desired effect depending on the luminance difference of a subject and the shooting conditions.
- When the flash is used, this function has little effect.
- When the contrast of the scene is low or when significant camera shake or subject blur has occurred, you may not obtain good HDR images. If the camera detects such situation,  is indicated on the recorded image to inform you of this situation. Shoot again, as necessary, recomposing or paying attention to the blur.



# Creative Style



Allows you to select the desired image processing.

You can adjust exposure (shutter speed and aperture) as you like with [Creative Style], unlike with [Scene Selection] where the camera adjusts the exposure.

- 1 [Menu] → [Brightness/Color] → [Creative Style] → desired mode.
- 2 When you want to adjust contrast, saturation, or sharpness, [Option] → desired setting.

✓	 <b>(Standard)</b>	For shooting various scenes with rich gradation and beautiful colors.
	 <b>(Vivid)</b>	The saturation and contrast are heightened for shooting striking images of colorful scenes and subjects such as flowers, spring greenery, blue sky, or ocean views.
	 <b>(Portrait)</b>	For shooting the skin color in a soft tone, ideally suited for shooting portraits.
	 <b>(Landscape)</b>	The saturation, contrast, and sharpness are heightened for shooting vivid and crisp scenery. Distant landscapes also stand out more.
	 <b>(Sunset)</b>	For shooting the beautiful red of the setting sun.
	 <b>(Black &amp; White)</b>	For shooting images in black and white monotone.

 (Contrast),  (Saturation), and  (Sharpness) can be adjusted for each Creative Style item.

 <b>(Contrast)</b>	The higher the value selected, the more the difference of light and shadow is accentuated, thus making an impact on an image.
 <b>(Saturation)</b>	The higher the value selected, the more vivid the color. When a lower value is selected, the color of the image is restrained and subdued.
 <b>(Sharpness)</b>	Adjusts the sharpness. The higher the value selected, the more the contours are accentuated, and the lower the value selected, the more the contours are softened.

## Notes

- When [Black & White] is selected, you cannot adjust the saturation.
- [Standard] is selected when using the following functions:
  - [Intelligent Auto]
  - [Scene Selection]

# Delete

Allows you to select unwanted images for deletion.

1 [Menu] → [Playback] → [Delete] → desired mode.

✓	<b>Multiple Img.</b>	Deletes the selected images. Press the center to confirm [Select] and [OK].
	<b>All in Folder</b>	Deletes all still images in the folder. This appears during still image playback only.
	<b>All in Date Rng.</b>	Deletes all movies of the date. This appears during movie playback only.

## Note

- You can select up to 100 images.



To delete an image

It is easier to delete an image displayed on the screen by selecting [Delete] (page 28).

# Slide Show

Plays back images automatically.

1 [Menu] → [Playback] → [Slide Show] → desired mode → [OK].

Interval		
<input checked="" type="checkbox"/>	<b>1 Sec</b>	Sets the display interval of images. Appears only when playing back still images.
	<b>3 Sec</b>	
	<b>5 Sec</b>	
	<b>10 Sec</b>	
	<b>30 Sec</b>	
Movie Type		
<input checked="" type="checkbox"/>	<b>All</b>	Selects the movie type to play back. Appears only when playing back movies.
	<b>AVCHD</b>	
	<b>MP4</b>	
Repeat		
	<b>On</b>	Plays back images in a continuous loop.
<input checked="" type="checkbox"/>	<b>Off</b>	After all the images have been played back, the slide show ends.

## Notes

- You cannot pause the slide show. To stop the slide show, press the center of the control wheel.
- You cannot play back still images and movies together. Select either type of image with [Still/Movie Select].
- A panoramic image is displayed in full image. To scroll a panoramic image, first stop the slide show by pressing the center of the control wheel when the image is displayed, and then press the center again.

# Still/Movie Select

Selects still images or movies to play back.

1 [Menu] → [Playback] → [Still/Movie Select] → desired mode.

✓	<b>Still</b>	Displays the still image.
	<b>Movie</b>	Displays the movie.



## Note

- You cannot display still images and movies on the same index screen.

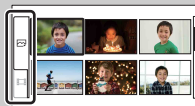

## Switching between the still image and the movie





You can switch the image type on the image index easily. Select  (still image) or  (movie) on the left of the screen.

# Image Index

Selects the number of images to be displayed on the index.

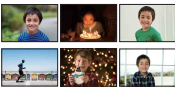

1 [Menu] → [Playback] → [Image Index] → desired mode.

✓	<b>6 Images</b>	Displays six images.	
	<b>12 Images</b>	Displays 12 images.	

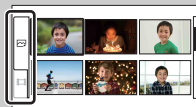
## 💡 Switching between the still image and the movie



You can switch the image type on the image index easily.

Select  (still image) or  (movie) on the left of the screen.

You cannot display still image and movie on the same index screen.

# Select Folder

When multiple folders are created in a memory card, this selects the folder containing the still image you want to play back.

- 1 [Menu] → [Playback] → [Still/Movie Select] → [Still].
- 2 [Menu] → [Playback] → [Select Folder] → desired folder.



## Note

- You cannot select this item during movie playback.

# Select Date

Movies are stored by date. You can select the date of movies to be played back.

- 1 [Menu] → [Playback] → [Still/Movie Select] → [Movie].
- 2 [Menu] → [Playback] → [Select Date] → desired date.



## Note

- You cannot select this item during still image playback.

Table of contents

Sample photo search

Menu search

Index

# Rotate

Rotates a still image counter-clockwise. Use this to display a horizontal orientation image in vertical orientation. Once you rotate the image, the image is played back in the rotated position, even if you turn off the power.

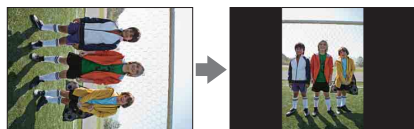

1 [Menu] → [Playback] → [Rotate] → press the center.

The image rotates counter-clockwise. The image rotates as you press the center.

## Notes

- You cannot rotate movies or protected images.
- You may not be able to rotate images shot with other cameras.
- When viewing images on a computer, the image rotation information may not be reflected depending on the software.

# Protect

Protects recorded images against accidental erasure.

The  mark is displayed for registered images.

1 [Menu] → [Playback] → [Protect] → desired mode.

	<b>Multiple Img.</b>	Applies or cancels the protection of the selected images. Press the center to confirm [Select] and [OK].
	<b>Cancel All Images</b>	Cancels the protection of all still images.
	<b>Cancel All Movies</b>	Cancels the protection of all movies.

## Note

- You can protect up to 100 images at a time.

# Enlarge Image

You can check the focus by enlarging a portion of the playback image.

- 1 [Menu] → [Playback] → [ Enlarge Image].
- 2 Adjust the scaling by turning the control wheel.
- 3 Select the portion you want to enlarge by pressing the top/bottom/right/left of the control wheel.
- 4 To cancel the operation, press [Exit].

## Notes

- You cannot enlarge the movies.
- During playing back panoramic images, pause first, and then enlarge the image.

## Scaling range

The scaling range depends on the image size.

Image size	Scaling range
L	Approx. $\times 1.1 - \times 13$
M	Approx. $\times 1.1 - \times 10$
S	Approx. $\times 1.1 - \times 6.7$

# Volume Settings

Adjusts the sound volume of movies in eight steps. This item appears during movie playback only.

1 [Menu] → [Playback] → [Volume Settings] → desired value.

## Adjusting the volume during playback

The [Volume Settings] screen appears when you press the bottom of the control wheel while playing back movies.

You can adjust the volume, while listening to the actual sound.

Table of contents

Sample photo search

Menu search

Index

# Specify Printing

You can specify which and how many copies of still images you shot on the memory card that you want to print out later.

The **DPOF** (Print order) mark is displayed for registered images (DPOF: Digital Print Order Format).

1 [Menu] → [Playback] → [Specify Printing] → desired setting.

DPOF Setup		
<input checked="" type="checkbox"/>	<b>Multiple Img.</b>	Selects images to order printing. ① Press the center to select the number of sheets. To cancel DPOF, hold the center down until the DPOF mark turns off. ② Repeat the operation on all images you want to print.
	<b>Cancel All</b>	Clears all DPOF marks.
Date Imprint		
	<b>On</b>	Sets whether or not to date the DPOF marked images when printing them.
<input checked="" type="checkbox"/>	<b>Off</b>	

## Notes

- You cannot add the DPOF mark to movies.
- You can add the DPOF mark to up to 998 images.
- DPOF registration is not cleared after printing. It is recommended that you clear it after you print the still images.

# AF Illuminator

The AF illuminator supplies fill light to focus more easily on a subject in dark surroundings.

The red AF illuminator allows the camera to focus easily when the shutter button is pressed halfway, until the focus is locked.

1 [Menu] → [Setup] → [AF Illuminator] → desired setting.

✓	<b>Auto</b>	Uses the AF illuminator.
	<b>Off</b>	Does not use the AF illuminator.

## Notes

- You cannot use the AF illuminator when:
  - [Autofocus Mode] is set to [Continuous AF].
  - [Landscape], [Night View], [Hand-held Twilight] or [Sports Action] in [Scene Selection] is selected.
  - [Sweep Panorama] is selected.
  - Recording movies.
  - using an A-mount lens
- When you use the AF illuminator, the normal AF range finder frame is disabled and a new AF range finder frame is displayed by a dotted line. AF operates with priority on subjects located near the center of the frame.

# Red Eye Reduction

The flash strobos two or more times before shooting to reduce the red-eye phenomenon when using the flash.

1 [Menu] → [Setup] → [Red Eye Reduction] → desired setting.

	<b>On</b>	The flash always strobos to reduce the red-eye phenomenon.
✓	<b>Off</b>	Does not use Red Eye Reduction.

## Notes

- Attach and raise the flash to use Red Eye Reduction.
- You cannot use [Red Eye Reduction] with [Smile Shutter].
- Red Eye Reduction may not produce the desired effects. It depends on individual differences and conditions, such as distance to the subject, or if the subject looked away from the pre-strobe.

## 💡 What causes the red-eye phenomenon?

Pupils become dilated in dark environments. Flash light is reflected off the blood vessels at the back of the eye (retina), causing the “red-eye” phenomenon.

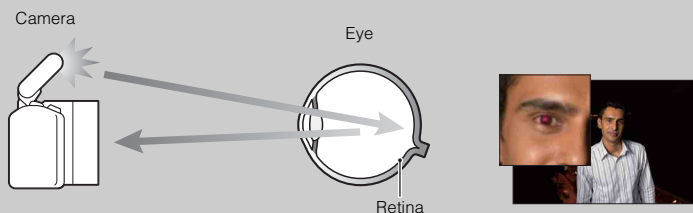

# Auto Review

You can check the recorded image on the LCD monitor right after the shooting. You can change the displayed time.

1 [Menu] → [Setup] → [Auto Review] → desired setting.

	<b>10 Sec</b>	Displays for the set time.
	<b>5 Sec</b>	
	<b>2 Sec</b>	
✓	<b>Off</b>	Does not display.

## Notes

- In auto review, the image will not be displayed in the vertical position even if [Playback Display] is set to [Auto Rotate].
- Even if [Grid Line] is set to [On] when recording [Sweep Panorama] images, the grid line does not appear in auto review.

# Grid Line

Sets whether the grid line is displayed or not. The grid line will help you to adjust the composition of images.

1 [Menu] → [Setup] → [Grid Line] → desired setting.

	<b>On</b>	Displays the grid line.
✓	<b>Off</b>	Does not display the grid line.



## Checking the frame for movie recording

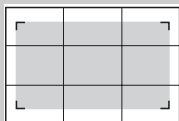

Frame for movie

The frame that appears when [Grid Line] is set to [On] will show to what extent your subject is included in the frame. This enables you to adjust the composition by moving closer or further away from your subject.

# Histogram

Sets whether the histogram is displayed or not. The histogram displays the luminance distribution that shows how many pixels of a particular brightness exist in the image.

1 [Menu] → [Setup] → [Histogram] → desired setting.

	<b>On</b>	Displays the histogram.
✓	<b>Off</b>	Does not display the histogram.

## Note

- You cannot display the histogram in the following modes:
  - Movie recording
  - [Sweep Panorama]

## 💡 What is histogram

The histogram displays the luminance distribution that shows how many pixels of a particular brightness exist in the picture. Brighter image will make the entire histogram shift to the right side, and darker image to the left side.

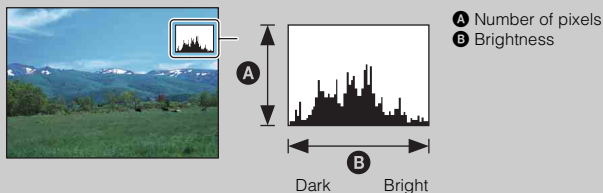

# MF Assist

Enlarges the image on the screen automatically to make manual-focusing easier. This works in the [Manualfocus] or [DMF] modes.

1 [Menu] → [Setup] → [MF Assist] → [On].

2 Turn the focusing ring to adjust the focus.

The image is enlarged by seven times. You can enlarge the image also by 14 times.

✓	<b>On</b>	Enlarges the image.
	<b>Off</b>	Does not enlarge the image.

## Notes

- You cannot use [MF Assist] with the following functions:
  - Movie recording
  - [Precision Dig. Zoom]
- When an A-mount lens (sold separately) is attached, pressing [MF Assist] (soft key) will enlarge the image.

# Color Space

The way colors are represented with combinations of numbers or the range of color reproduction is called “color space.” You can change the color space, depending on your purpose.

1 [Menu] → [Setup] → [Color Space] → desired setting.

✓	<b>sRGB</b>	This is the standard color space of the digital camera. Use sRGB in normal shooting, such as when you intend to print out the images without any modification.
	<b>AdobeRGB</b>	This has a wide range of color reproduction. When a large part of the subject is vivid green or red, Adobe RGB is effective. The file name of the image starts with “_DSC.”

## Notes

- Adobe RGB is for applications or printers that support color management and DCF2.0 option color space. Using some applications or printers that do not support them may result in or print images that do not faithfully reproduce the color.
- When displaying images that were recorded with Adobe RGB on the camera or non-Adobe RGB-compliant devices, the images are displayed with low saturation.

# SteadyShot

Sets whether or not you use the SteadyShot function of the lens.

1 [Menu] → [Setup] → [SteadyShot] → desired setting.

✔	<b>On</b>	Uses SteadyShot.
	<b>Off</b>	Does not use SteadyShot. This setting is recommended when you use a tripod.

## Notes

- [On] is selected when using the following functions:
  - [Hand-held Twilight] in [Scene Selection]
  - [Anti Motion Blur]
- You cannot set [SteadyShot] when an E16 mm F2.8 or A-mount lens (sold separately) is attached.

# Release w/oLens

Sets whether or not the shutter can be released when no lens is attached.

1 [Menu] → [Setup] → [Release w/oLens] → desired setting.

	<b>Enable</b>	Releases the shutter when no lens is attached. Select this when you attach the camera on an astronomical telescope, etc.
✓	<b>Disable</b>	Releases the shutter only when a lens is attached.

Table of contents

Sample photo search

Menu search

Index

# Long Exposure NR

When you set the shutter speed to a second or longer (Long exposure shooting), noise reduction is turned on for the same duration that the shutter is open. This is to reduce the grainy noise typical in a long exposure.

1 [Menu] → [Setup] → [Long Exposure NR] → desired setting.

✓	<b>On</b>	Activates noise reduction for the same duration that the shutter is open. When noise reduction is in progress, a message appears and you cannot take another picture. Select this to prioritize the image quality.
	<b>Off</b>	Does not activate noise reduction. Select this to prioritize the timing of shooting.

## Notes

- Noise reduction is not performed when using the following functions, even when it is set to [On]:
  - [Continuous Adv.]
  - [Speed Priority Cont.]
  - [Bracket: Cont.]
  - [Hand-held Twilight] in [Scene Selection]
  - [Anti Motion Blur]
  - [Sweep Panorama]
- You cannot change [Long Exposure NR] when using the following functions:
  - [Intelligent Auto]
  - [Scene Selection]
  - [Anti Motion Blur]
  - [Sweep Panorama]

# High ISO NR

When shooting with the high ISO, the camera reduces the noise that becomes more noticeable when the camera sensitivity is high.

1 [Menu] → [Setup] → [High ISO NR] → desired setting.

✓	<b>Auto</b>	Activates high ISO noise reduction automatically.
	<b>Weak</b>	Activates high ISO noise reduction moderately.

## Note

- You cannot set [High ISO NR] when using [Sweep Panorama].

# Movie Audio Rec

Sets whether or not you record the sound during movie recording.

1 [Menu] → [Setup] → [Movie Audio Rec] → desired setting.

✓	<b>On</b>	Records sound (stereo).
	<b>Off</b>	Does not record sound.

## Note

- The sound of the lens and the camera in operation will also be recorded, when [On] is selected.

# Beep

Selects the sound produced when you operate the camera.

1 [Menu] → [Setup] → [Beep] → desired setting.

	<b>AF Sound</b>	The audio signals will sound only when the subject is in focus, and during self-timer countdown.
✓	<b>High</b>	Turns on audio signals when you press the control wheel, or soft keys.
	<b>Low</b>	If you want to lower the volume, select [Low].
	<b>Off</b>	Turns off the audio signal.

# Language

Selects the language to be used in the menu items, warnings and messages.

1 [Menu] → [Setup] →  Language → desired language.

Table of contents

Sample photo search

Menu search

Index

# Date/Time Setup

Sets the date and time again.

1 [Menu] → [Setup] → [Date/Time Setup].

2 Set the date, time, etc.

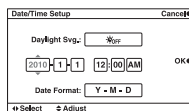

<b>Daylight Svc.</b>	Selects [ON] or [OFF].
<b>Date Format</b>	Selects the date and time display format.

## Note

- The camera does not have a feature for superimposing dates on images. By using “PMB” in the CD-ROM (supplied), you can print or save images with the date.

Table of contents

Sample photo search

Menu search

Index

# Area Setting

Sets the area where you are using the camera. This allows you to set the local area when you use the camera abroad.

- 1 [Menu] → [Setup] → [Area Setting] → desired setting.
- 2 Press the right or left of the control wheel to select an area.

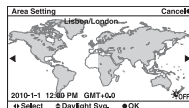

Table of contents

Sample photo search

Menu search

Index

# Help Guide Display

You can select whether or not the help guide is displayed when you operate the camera.

1 [Menu] → [Setup] → [Help Guide Display] → desired setting.

✔	<b>On</b>	Displays the help guide.
	<b>Off</b>	Does not display the help guide. This is convenient when you want to perform the next operation quickly.

Table of contents

Sample photo search

Menu search

Index

# Power Save

You can set time intervals for the camera to switch to power save mode. Pressing the shutter button halfway down returns the camera to the shooting mode.

1 [Menu] → [Setup] → [Power Save] → desired setting.

✓	<b>1 Min</b>	Switches to power save mode after the set time.
	<b>5 Min</b>	
	<b>10 Min</b>	
	<b>30 Min</b>	

## Notes

- Regardless of the setting here, the camera turns to power save mode after 30 minutes when the camera is connected to a TV or the drive mode is set to [Remote Cdr.].
- Turn off the camera when you do not use it for a long time.

# LCD Brightness

The brightness of the LCD monitor is automatically adjusted to the ambient lighting conditions using the light sensor (page 12). You can set the brightness of the LCD monitor manually.

1 [Menu] → [Setup] → [LCD Brightness] → desired setting.

✓	<b>Auto</b>	Adjust the brightness automatically.
	<b>Manual</b>	Allows you to adjust the brightness within the range of -2 to +2.
	<b>Sunny Weather</b>	Automatically adjusts the brightness appropriately for shooting outdoors.

## Notes

- When this is set to [Auto], do not cover the light sensor with your hand and so on.
- When using the camera with the AC-PW20 AC Adaptor (sold separately), the brightness of the LCD monitor is always set as bright as +2 even if you select [Auto].

# Display Color

Selects the color of the LCD monitor.

1 [Menu] → [Setup] → [Display Color] → desired setting.

	<b>Black</b>	Turns to the selected color.
✓	<b>White</b>	
	<b>Blue</b>	
	<b>Pink</b>	

Table of contents

Sample photo search

Menu search

Index

# Wide Image

Selects the method used for displaying the wide images.

1 [Menu] → [Setup] → [Wide Image] → desired setting.



	<b>Full Screen</b>	Displays the wide images on the entire screen.	
✓	<b>Normal</b>	Displays the wide images and the operation information on the screen.	

Table of contents

Sample photo search

Menu search

Index

# Playback Display

Selects the orientation when playing back still images recorded in the portrait position.

1 [Menu] → [Setup] → [Playback Display] → desired setting.

✓	<b>Auto Rotate</b>	Displays in the portrait position.
	<b>Manual Rotate</b>	Displays in the landscape position.

## Note

- When you play back the image on a TV or a computer, the image will be displayed in the portrait position even if [Manual Rotate] is selected.

# CTRL FOR HDMI

When connecting the camera to a “BRAVIA” Sync compatible TV with an HDMI cable (sold separately), you can play back images on your camera by the TV’s remote control aiming at the TV. See page 124 on “BRAVIA” Sync.

1 [Menu] → [Setup] → [CTRL FOR HDMI] → desired setting.

✓	<b>On</b>	Operates the camera with the TV remote control.
	<b>Off</b>	Does not operate the camera with the TV remote control.

## Note

- You can perform the operation of the camera with the remote control of your TV by connecting your camera to a “BRAVIA” Sync compatible TV.

# USB Connection

Selects the method used for a USB connection.

1 [Menu] → [Setup] → [USB Connection] → desired setting.

✓	<b>Mass Storage</b>	Establishes a Mass Storage connection between the camera, a computer, and other USB devices. Standard mode.
	<b>PTP</b>	When you connect the camera to a computer, the AutoPlay Wizard appears, and the still images in the recording folder on the camera are imported to the computer (with Windows 7/Vista/XP, Mac OS X).

## Note

- You cannot import movies and RAW images with [PTP].

# Cleaning Mode

Allows you to clean the image sensor.

1 [Menu] → [Setup] → [Cleaning Mode] → [OK].

The message “After cleaning, turn camera off. Continue?” appears.

2 Confirm [OK].

The anti-dust is activated automatically.

3 Turn the camera off.

4 Detach the lens.

5 Use the blower to clean the image sensor surface and the surrounding area.

6 Attach the lens.

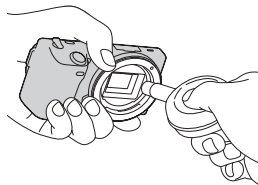

## Notes

- Cleaning can be performed only when the battery level is  (three remaining battery icons) or more. The use of an AC-PW20 AC Adaptor (sold separately) is recommended.
- Do not use a spray blower because it may scatter water droplets inside the camera body.
- Do not put the tip of a blower into the cavity beyond the mount, so that the tip of the blower does not touch the image sensor.
- Hold the camera's face downward to prevent the dust from resettling in the camera.
- Do not apply a mechanical shock to the camera during cleaning.

# Version

Displays the version of your camera and lens. Confirm the version when a firmware update is released.

1 [Menu] → [Setup] → [Version].

## Note

- An update can be performed only when the battery level is  (three remaining battery icons) or more. We recommend that you use a sufficient battery or the AC-PW20 AC Adaptor (sold separately).

Table of contents

Sample photo search

Menu search

Index

# Demo Mode

The [Demo Mode] function displays the movies recorded on the memory card automatically (demonstration), when the camera has not been operated for a certain time. Normally select [Off].

1 [Menu] → [Setup] → [Demo Mode] → desired setting.

	<b>On</b>	The demonstration begins automatically when the camera is not operated for about one minute.
✓	<b>Off</b>	Does not show the demonstration.

## Notes

- Even if [On] is selected, the camera does not start a demonstration when there is no movie recorded on the memory card.
- When [On] is selected, the camera does not switch to power save mode.

# Reset Default

Initializes the setting to the default setting.

Even if you activate [Reset Default], the images are retained.

1 [Menu] → [Setup] → [Reset Default] → [OK].

## Notes

- Be sure not to turn off the camera while resetting.
- The settings of [Date/Time Setup] and [Area Setting] are not reset.

# Format

Formats the memory card. When you use a memory card with this camera for the first time, it is recommended to format the card using the camera for stable performance of the memory card before shooting. Note that formatting permanently erases all data on the memory card, and is unrecoverable. Save precious data on a computer, etc.

1 [Menu] → [Setup] → [Format] → [OK].

## Notes

- Formatting permanently erases all data including even protected images.
- During the format, the access lamp lights up. Do not eject the memory card while the lamp is lit.
- Format the memory card using the camera. If you format it on a computer, the memory card may not be usable with the camera, depending on the format type used.

# File Number

Selects the method for assigning file numbers to images.

1 [Menu] → [Setup] → [File Number] → desired setting.

✓	<b>Series</b>	The camera does not reset numbers, and assigns numbers to files in sequence until the number reaches “9999.”
	<b>Reset</b>	The camera resets numbers in the following cases and assigns numbers to files from “0001.” When the recording folder contains a file, a number incremented one higher than the largest number is assigned. <ul style="list-style-type: none"><li>• When the folder format is changed.</li><li>• When all the images in the folder are deleted.</li><li>• When the memory card is replaced.</li><li>• When the memory card is formatted.</li></ul>

Table of contents

Sample photo search

Menu search

Index

# Folder Name

Still images you shoot are recorded in a folder that is automatically created under the DCIM folder on the memory card. You can change the folder name form.

1 [Menu] → [Setup] → [Folder Name] → desired setting.

✓	<b>Standard Form</b>	The folder name form is as follows: folder number + MSDCF. Example: 100MSDCF
	<b>Date Form</b>	The folder name form is as follows: folder number + Y (the last digit)/MM/DD. Example: 10000405 (Folder name: 100, date: 04/05/2010)

## Note

- The MP4 movie folder form is fixed as “folder number + ANV01” (NEX-5/5C), or “folder number + MNV01” (NEX-3). You cannot change this name.

# Select Shoot. Folder

When a standard form folder is selected and there are two or more folders, you can select the recording folder to be used to record still images.

1 [Menu] → [Setup] → [Select Shoot. Folder] → desired folder.

## Notes

- You cannot select the folder when you select the [Date Form] setting.
- Movie (MP4) files are recorded in a folder for movies that has the same number as the selected folder for still images.

# New Folder

Creates a folder in the memory card for recording images.

Images are recorded in the newly created folder until you create another folder or select another recording folder.

1 [Menu] → [Setup] → [New Folder] → [OK].

A new folder is created with a number incremented one higher than the largest number currently used.

## Notes

- A folder for still images and a folder for movies that have the same number are created at the same time.
- When you insert a memory card that was used with other equipment into the camera and shoot images, a new folder may be automatically created.
- Up to 4,000 images in total can be stored in the folders for still images or movies, respectively, with the same number. When the folder capacity is exceeded, a new folder is created automatically.

# Recover Image DB

When inconsistencies are found in the image database file of movies, caused by processing movies on computers, etc., movies on the memory card will not be played back in this form. If this happens, the camera repairs the file.

1 [Menu] → [Setup] → [Recover Image DB] → [OK].

The [Recover Image DB] screen is displayed, and the camera repairs the file.

Wait as it is until repairing is completed.

## Note

- Use a sufficiently charged battery. Low battery power during repairing can cause damage to data.

# Display Card Space

Displays the remaining recording time of movies on the memory card. Number of recordable still images is also displayed.

1 [Menu] → [Setup] → [Display Card Space] → [OK].

Table of contents

Sample photo search

Menu search





Index

# Upload Settings

Sets whether or not you use the upload function when using an Eye-Fi card (commercially available). This item appears when an Eye-Fi card is inserted in the camera.

NEX-5C does not have this function.

1 [Menu] → [Setup] → [Upload Settings] → desired setting.

✓	<b>On</b>	Enables the upload function. The icon on the screen changes according to the communication status of the camera.  Standby. No images are to be sent.  Connecting.  Upload standby.  Uploading.  Error
	<b>Off</b>	Disables the upload function.

## Notes

- Eye-Fi cards can be used only in the countries/regions where they were purchased. Use Eye-Fi cards in accordance with the law of the countries/regions where you purchased the card.
- Do not use an Eye-Fi card inserted in the camera on an airplane. If there is an Eye-Fi card inserted in the camera, set [Upload Settings] to [Off].  is displayed on the screen when [Upload Settings] is set to [Off].

## Transferring images using an Eye-Fi card



1 Set your Wi-Fi network or destination on the Eye-Fi card.

For details, refer to the manual supplied with the Eye-Fi card.

2 Insert the Eye-Fi card you have set up into the camera, and shoot still images.

Images are transferred to your computer, etc., automatically via the Wi-Fi network.

## Notes

- When you use a brand-new Eye-Fi card for the first time, copy the install file of Eye-Fi manager recorded on the card to your computer before formatting the card.
- Use an Eye-Fi card after updating the firmware to the latest version. For details, refer to the manual that comes with the Eye-Fi card.
- The power save function of the camera does not work while it is transferring images.
- If  (error) is displayed, remove the memory card and reinsert it, or turn off then turn on the power again. If  appears again, the Eye-Fi card may be damaged.
- Wi-Fi network communication may be influenced by other communication devices. If the communication status is poor, move closer to the access point of the Wi-Fi network.
- You cannot upload movies.

# Viewing images on a TV

To view images recorded on the camera on a TV, an HDMI cable (sold separately) and an HD TV equipped with an HDMI connector are required. Refer also to the operating instructions supplied with the TV.

- 1 Turn off both your camera and the TV.
- 2 Connect the camera to the TV with an HDMI cable (sold separately).
- 3 Turn on the TV and switch the input.
- 4 Turn on the camera.

Images shot with the camera appear on the TV screen.  
Select the desired image with the control wheel.

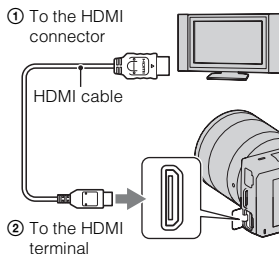

## Notes

- Some devices may not work properly.
- Use an HDMI cable with the HDMI logo.
- Use an HDMI mini connector on one end (for the camera), and a plug suitable for connecting your TV on the other end.
- If you record movies when the camera is connected to a TV with an HDMI cable, recording will be stopped after a while automatically to protect the devices.
- Do not connect the output connector of the device with the HDMI terminal on the camera. This may cause a malfunction.

## 💡 On “PhotoTV HD”

This camera is compatible with the “PhotoTV HD” standard.

By connecting Sony’s PhotoTV HD-compatible devices using an HDMI cable (sold separately), a whole new world of photos can be enjoyed in breathtaking Full HD quality. “PhotoTV HD” allows for a highly-detailed, photo-like expression of subtle textures and colors. For details, refer to the operating instructions supplied with the TV.

## Using “BRAVIA” Sync

By connecting the camera to a TV that supports “BRAVIA” Sync using an HDMI cable (sold separately), you can operate the camera with the TV Remote Control.

### 1 Connect a TV that supports “BRAVIA” Sync to the camera.

The input is automatically switched and the image shot with the camera appears on the TV screen.

### 2 Press the SYNC Menu button on the TV Remote Control.

### 3 Operate with the buttons on the TV Remote Control.

Item	Operation
Slide Show	Plays back images automatically
Play 1 Image	Returns to the single-image screen.
Still/Movie Select	Selects still image or movie to be played back.
Image Index	Switches to the image index screen.
Select Folder	Selects the folder of images to be played back.
Select Date	Selects the date of movies to be played back.
Delete	Deletes the image.

### Notes

- The operations available are restricted when the camera is connected to a TV using an HDMI cable.
- Only TVs that support “BRAVIA” Sync can provide SYNC Menu operations. The SYNC Menu operations differ depending on the TV connected. For details, refer to the operating instructions supplied with the TV.
- If the camera performs unnecessary operations in response to the TV Remote Control when the camera is connected to another manufacturer’s TV using an HDMI connection, operate [Menu] → [Setup] → [CTRL FOR HDMI] → [Off].

# Using with your computer

Following applications are contained on the CD-ROM (supplied) to allow more versatile use of images shot with your camera.

- Sony Image Data Suite
  - “Image Data Converter SR”
  - “Image Data Lightbox SR”
- “PMB” (Picture Motion Browser)

## Note

- “PMB” is not compatible with Macintosh computers.

## Recommended computer environment (Windows)

The following computer environment is recommended when using the supplied software and importing images via a USB connection.

OS (pre-installed)	Microsoft Windows XP* <sup>1</sup> SP3/Windows Vista* <sup>2</sup> SP2/ Windows 7
“PMB”	<b>CPU:</b> Intel Pentium III 800 MHz or faster (NEX-5/5C: For playing/editing the High Definition movies: Intel Core Duo 1.66 GHz or faster/Intel Core 2 Duo 1.66 GHz or faster NEX-3: For playing/editing the movies: Intel Core Duo 1.66 GHz or faster /Intel Core 2 Duo 1.20 GHz or faster) <b>Memory:</b> 512 MB or more (For playing/editing the High Definition movies: 1 GB or more) <b>Hard Disk:</b> Disk space required for installation—approximately 500 MB <b>Display:</b> Screen resolution—1024 × 768 dots or more
“Image Data Converter SR Ver.3” “Image Data Lightbox SR”	<b>CPU/Memory:</b> Pentium 4 or faster/1 GB or more <b>Display:</b> 1024 × 768 dots or more

\*<sup>1</sup> 64-bit editions and Starter (Edition) are not supported. Windows Image Mastering API (IMAPI) Ver.2.0 or later is required to use the function for creating discs.

\*<sup>2</sup> Starter (Edition) is not supported.

## Recommended computer environment (Macintosh)

The following computer environment is recommended when using the supplied software and importing images via a USB connection.

<b>OS (pre-installed)</b>	<b>USB Connection:</b> Mac OS X (v10.3 to v10.6) <b>“Image Data Converter SR Ver.3”/“Image Data Lightbox SR”:</b> Mac OS X v10.4/Mac OS X v10.5/ Mac OS X v10.6 (Snow Leopard)
<b>“Image Data Converter SR Ver.3” “Image Data Lightbox SR”</b>	<b>CPU:</b> Power PC G4/G5 series (1.0 GHz or faster is recommended)/Intel Core Solo/Core Duo/Core 2 Duo or faster <b>Memory:</b> 1 GB or more is recommended. <b>Display:</b> 1024 × 768 dots or more

### Notes

- Operation is not assured in an environment based on an upgrade of the operating systems described above or in a multi-boot environment.
- If you connect two or more USB devices to a single computer at the same time, some devices, including the camera, may not operate, depending on the types of USB devices you are using.
- Connecting the camera using a USB interface that is compatible with Hi-Speed USB (USB 2.0 compliant) allows advanced transfer (high speed transfer), as the camera is compatible with Hi-Speed USB (USB 2.0 compliant).
- When your computer resumes activity from suspend or sleep mode, communication between the camera and your computer may not recover at the same time.

Table of contents

Sample photo search

Menu search

Index

# Using the software

## Installing the software (Windows)

Log on as Administrator.

- 1 Turn on your computer, and insert the CD-ROM (supplied) into the CD-ROM drive.

The installation menu screen appears.

- If it does not appear, double-click [Computer] (For Windows XP: [My Computer]) → (SONYPMB) → [Install.exe].
- If the AutoPlay screen appears, select “Run Install.exe” and follow the instructions that appear on the screen to proceed with the installation.

- 2 Click [Install].

Make sure that both “Sony Image Data Suite” and “PMB” are checked and follow the instructions on the screen.

- Connect the camera to the computer during the procedure following the instructions on the screen (page 130).
- When the restarting confirmation message appears, restart the computer following the instructions on the screen.
- DirectX may be installed depending on the system environment of your computer.

- 3 Remove the CD-ROM after the installation is complete.

The following software is installed and shortcut icons appear on the desktop.

“Image Data Converter SR”  
“Image Data Lightbox SR”  
“PMB”  
“PMB Launcher”  
“PMB Help”

### Notes

- If “PMB” has already been installed on the computer, and the version number of the previously installed “PMB” is lower than that of the “PMB” on the CD-ROM (supplied), install “PMB” also from the CD-ROM (supplied).
- If a version of “PMB” under 5.0.00 has been installed on your computer, you may be unable to use some functions of those “PMB” when installing the “PMB” from the supplied CD-ROM. Also, “PMB Launcher” is installed from the supplied CD-ROM and you can start “PMB” or other software by using the “PMB Launcher.” Double-click the “PMB Launcher” short-cut icon on the computer screen to start “PMB Launcher.”

## Installing the software (Macintosh)

Log on as Administrator.

- 1 Turn on your Macintosh computer, and insert the CD-ROM (supplied) into the CD-ROM drive.
- 2 Double-click the CD-ROM icon.
- 3 Copy the [IDS\_INST.pkg] file in the [MAC] folder to the hard disk icon.
- 4 Double-click the [IDS\_INST.pkg] file in the copy-to folder.  
Follow the instructions on the screen to complete the installation.

## Using “Image Data Converter SR”

With “Image Data Converter SR” you can do the following, etc.:

- To edit images recorded in RAW format with various corrections, such as tone curve, and sharpness.
- To adjust images with white balance, exposure, and creative style, etc.
- To save the images displayed and edited on a computer.

You can either save the image as RAW format or save it in the general file format.

### To use “Image Data Converter SR”

Refer to Help.

Click [Start] → [All Programs] → [Sony Image Data Suite] → [Help] → [Image Data Converter SR Ver.3].

“Image Data Converter SR” support page (English only)  
<http://www.sony.co.jp/ids-se/>

## Using “Image Data Lightbox SR”

With “Image Data Lightbox SR” you can do the following, etc.:

- To display and compare RAW/JPEG images recorded with this camera.
- To rate the images on a scale of five.
- To set color labels and so on.
- To display an image with “Image Data Converter SR” and make adjustments to it.

### To use “Image Data Lightbox SR”

Refer to Help.

Click [Start] → [All Programs] → [Sony Image Data Suite] → [Help] → [Image Data Lightbox SR].

“Image Data Lightbox SR” support page (English only)

<http://www.sony.co.jp/ids-se/>

## Using “PMB”

With “PMB” you can do the following, etc.:

- To set images shot with the camera and display them on the computer.
- To organize images on the computer on a calendar by shooting date to view them.
- To retouch (Red Eye Correction, etc.), print, and send still images as e-mail attachments, change the shooting date and more.
- To print or save still images with the date.
- To create Blu-ray discs, AVCHD format discs or DVD discs from AVCHD format movies imported to a computer. (An internet connection environment is required when a Blu-ray disc/DVD disc is created for the first time.) (NEX-5/5C only)

### Note

- “PMB” is not compatible with Macintosh computers.

### To use “PMB”

Refer to “PMB Help.”

Double-click the shortcut of  (PMB Help) on the desktop. Or, click [Start] → [All Programs] → [PMB] → [PMB Help].

“PMB” support page (English only)

<http://www.sony.co.jp/pmb-se/>

# Connecting the camera to the computer

1 Insert a sufficiently charged battery pack into the camera, or connect the camera to a wall outlet (wall socket) using the AC-PW20 AC Adaptor (sold separately).

2 Turn on the computer, then press the  (Playback) button.

3 Connect the camera to your computer.

When a USB connection is established for the first time, your computer automatically runs a program to recognize the camera. Wait for a while.

① To a USB terminal of the computer

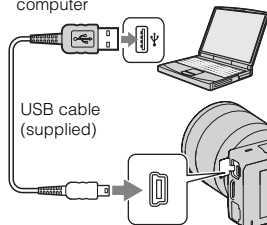

② To the USB terminal

## Importing images to the computer (Windows)

“PMB” allows you to easily import images.

For details on “PMB” functions, see the “PMB Help.”

### Importing images to the computer without using “PMB”

When the AutoPlay Wizard appears after making a USB connection between the camera and a computer, click [Open folder to view files] → [OK] → [DCIM] or [MP\_ROOT] → copy the desired images to the computer.

#### Notes

- For operations such as importing AVCHD movies to the computer, use “PMB” (NEX-5/5C only).
- When the camera is connected to the computer, if you operate AVCHD format movies or folders from the connected computer, images may be damaged or cannot be played. Do not delete or copy AVCHD format movies on the memory card from the computer. Sony is not held liable for consequences resulting from such operations via the computer (NEX-5/5C only).

## Importing images to the computer (Macintosh)

1 Connect the camera to your Macintosh computer first. Double-click the newly recognized icon on the desktop → the folder where the images you want to import are stored.

2 Drag and drop the image files to the hard disk icon.

The image files are copied to the hard disk.

3 Double-click the hard disk icon → the desired image file in the folder containing the copied files.

The image is displayed.

## Deleting the USB connection

Perform the procedures from step 1 to 3 below before:

- Disconnecting the USB cable.
  - Removing the memory card.
  - Turning off the camera.
- 1 Double-click the disconnect icon on the tasktray.
  - 2 Click  (USB Mass Storage Device) → [Stop].
  - 3 Confirm the device on the confirmation window, then click [OK].

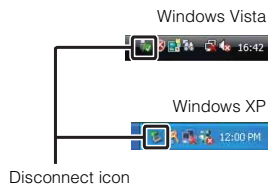

### Note

- Drag and drop the icon of the memory card or the drive icon to the "Trash" icon beforehand when you use a Macintosh computer, and the camera is disconnected from the computer.

# Creating a movie disc (NEX-5/5C)



You can create a disc from AVCHD format movies recorded on the camera.

## Selecting the method for creating a disc

Select the method that best suits your disc player.

See “PMB Help” for details on creating a disc using “PMB.”

To import movies, see page 130.

Player	Method	Disc type
Blu-ray disc playback devices (Blu-ray disc player, PlayStation@3, etc.)	Create a Blu-ray disc of movies and photos imported to a computer using “PMB.”	
AVCHD format playback devices (Sony Blu-ray disc player, PlayStation@3, etc.)	Create an AVCHD format disc of movies and photos imported to a computer using “PMB.”	
	Creating an AVCHD format disc with a DVD writer/recorder other than DVDirect Express.	
Ordinary DVD playback devices (DVD player, DVD playable computer, etc.)	Create a standard definition image quality (STD) disc of movies and photos imported to a computer using “PMB.”	

### Notes

- If you use a Sony DVDirect (DVD Writer), you can transfer data by inserting a memory card into the memory card slot of the DVD writer, or connecting your camera to the DVD writer with a USB cable.
- When you use Sony DVDirect (DVD writer), make sure that the version of DVD writer's firmware is the latest.

For details, refer to the following URL:

<http://sony.storagesupport.com/>

Table of  
contents

Sample photo  
search

Menu search

Index

## 💡 Characteristics of each type of disc



A Blu-ray disc enables you to record high definition image quality (HD) movies of a longer duration than DVD discs.



High definition image quality (HD) movie can be recorded on DVD media, such as DVD-R discs, and a high definition image quality (HD) disc is created.

- You can play a high definition image quality (HD) disc on AVCHD format playback devices, such as a Sony Blu-ray disc player and a PlayStation®3. You cannot play the disc on ordinary DVD players.



Standard definition image quality (STD) movie converted from high definition image quality (HD) movie can be recorded on DVD media, such as DVD-R discs, and a standard image quality (STD) disc is created.

## 💡 Discs you can use with “PMB”

You can use 12 cm discs of following type with “PMB.” For Blu-ray disc, see page 134.

Disc type	Features
DVD-R/DVD+R/DVD+R DL	Unrewritable
DVD-RW/DVD+RW	Rewritable

- Always maintain your PlayStation®3 to use the latest version of the PlayStation®3 system software.
- The PlayStation®3 may not be available in some countries/regions.

Table of contents

Sample photo search

Menu search

Index

## Creating an AVCHD format disc

You can create a high definition image quality (HD) AVCHD format disc from AVCHD format movies imported to a computer using the supplied software “PMB.”

- 1 Turn on your computer and place an empty disc on the DVD drive.
- 2 Start “PMB.”
- 3 Select the AVCHD format movies you want to write.
- 4 Click  (Disc Creation) to select [Create AVCHD Format Discs (HD)].
- 5 Follow the instructions on the screen to create a disc.

### Notes

- Install “PMB” beforehand.
- Still images and MP4 movie files cannot be recorded on the AVCHD format disc.
- It may take a long time to create a disc.



### Playing AVCHD format disc on a computer

You can play back AVCHD format discs using “Player for AVCHD” that is installed together with “PMB.”

To start the software, click on [Start] → [All Programs] → [PMB] → [PMB Launcher] → [View] → [Player for AVCHD].

For detailed operations, see the Help for “Player for AVCHD.”

- Movies may not be played smoothly depending on the computer environment.

## Creating a Blu-ray disc

You can create a Blu-ray disc with AVCHD movies previously imported to a computer. Your computer must support the creation of Blu-ray discs.

BD-R (non-rewritable) and BD-RE (rewritable) media can be used to create Blu-ray discs. You cannot add contents to either type of disc once it has been created.

Click [BD Add-on Software] on the installation screen of “PMB,” and install this plug-in according to the on-screen instructions.

Connect your computer to the Internet when you install [BD Add-on Software]. See “PMB Help” for details.

## Creating a standard definition image quality (STD) disc

You can create a standard definition image quality (STD) disc from AVCHD format movies imported to a computer using supplied software “PMB.”

- 1 Turn on your computer and place an empty disc on the DVD drive.
  - Close all software other than “PMB.”
- 2 Start “PMB.”
- 3 Select the movies you want to write.
- 4 Click  (Disc Creation) to select [Create DVD-Video Format Discs (STD)].
- 5 Follow the instructions on the screen to create the disc.

### Notes

- Install “PMB” beforehand.
- MP4 movie files cannot be recorded on a disc.
- It will take a longer time to create a disc because AVCHD format movies are converted to standard definition image quality (STD) movies.
- An Internet connection environment is required when creating a DVD-Video (STD) disc for the first time.

# Printing still images

You can print still images using the following methods.

- Printing directly using a printer which supports your memory card type  
For details, see the operating instructions supplied with the printer.
- Printing using a computer  
You can import images to a computer using the supplied “PMB” software and print the images. You can insert the date on the image and print it. For details, see the “PMB Help.”
- Printing at a shop  
You can take a memory card containing images shot with the camera to a photo printing service shop. As long as the shop supports photo printing services conforming to DPOF, you can make a **DPOF** (Print order) mark on images in advance in the playback mode so that you do not have to reselect them when you print them out at the shop.

## Notes

- You cannot print RAW images.
- When you print images shot in [16:9] mode, both edges may be cut off.
- You cannot print panoramic images depending on the printer.
- When you print at a shop, note the followings.
  - Consult your photo printing service shop as to what types of memory card they handle.
  - A memory card adaptor (sold separately) may be necessary. Consult your photo printing service shop.
  - Before you take image data to a shop, always copy (back up) your data to a disk.
  - You cannot set the number of prints.
  - If you want to superimpose dates on images, consult your photo printing service shop.

# Troubleshooting

If you experience trouble with the camera, try the following solutions.

- 1 Check the items on pages 137 to 142.
- 2 Remove the battery pack, wait for about one minute, re-insert the battery pack, then turn on the power.
- 3 Reset the settings (page 114).
- 4 Consult your Sony dealer or local authorized Sony service facility.

## Battery pack and power

### The battery pack cannot be installed.

- When you insert the battery pack, use the tip of the battery pack to push the lock lever.
- You can use an NP-FW50 battery pack only. Make sure that the battery is NP-FW50.

### The remaining battery indicator is incorrect, or sufficient remaining battery indicator is displayed but the power runs out too quickly.

- This phenomenon occurs when you use the camera in an extremely hot or cold location.
- The battery pack is discharged. Install a charged battery pack.
- The battery pack is dead. Replace it with a new one.

### Cannot turn on the camera.

- Install the battery pack correctly.
- The battery pack is discharged. Install a charged battery pack.
- The battery pack is dead. Replace it with a new one.

### The power turns off suddenly.

- When the camera or battery pack is too warm, the camera displays a warning message and turns off automatically to protect the camera.
- If you do not operate the camera for given period of time, the camera turns to power saving mode. To cancel the power save, operate the camera, such as pressing the shutter button halfway down (page 104).

### The CHARGE lamp flashes when charging the battery pack.

- You can use an NP-FW50 battery pack only. Make sure that the battery is NP-FW50.
- If you charge a battery pack that has not been used for a long time, the CHARGE lamp may flash.
- The CHARGE lamp flashes in two ways, fast (about 0.15-second intervals) and slow (about 1.5-second intervals). If it is flashing fast, remove the battery pack and reattach the same battery pack securely. If the CHARGE lamp flashes fast again, it suggests that there is something wrong with the

battery pack. Slow flashing indicates that charging is suspended because the ambient temperature is outside the suitable range for charging the battery pack. Charging will resume and the CHARGE lamp will be lit when the ambient temperature returns to within the suitable temperature.

- Charge the battery pack under the suitable temperatures between 10 °C and 30 °C (50 °F and 86 °F).

## Shooting images

### Nothing is displayed on the LCD monitor when the power is turned on.

- If you do not operate the camera for given period of time, the camera turns to power saving mode. To cancel the power save, operate the camera, such as pressing the shutter button halfway down (page 104).

---

### The shutter does not release.

- You are using a memory card with a write-protect switch, and the switch is set to the LOCK position. Set the switch to the recording position.
- Check the free capacity of the memory card.
- You cannot record images while charging the flash.
- The lens is not attached properly. Attach the lens properly.

---

### Recording takes a long time.

- The noise reduction function is turned on (pages 96, 97). This is not a malfunction.
- You are shooting in RAW mode (page 66). Since the RAW data file is large, the RAW mode shooting may take time.
- The Auto HDR is processing an image (page 74).

---

### The image is out of focus.

- The subject is too close. Check the minimum focal distance of the lens.
- You are shooting in manual focus mode. Set [AF/MF Select] to [Autofocus] (page 53).
- Ambient light is insufficient.
- The subject may require special focusing. Use the [Flexible Spot] (page 55) or manual focus function (page 53).

---

### The flash does not work.

- Raise the flash.
- The flash is not attached correctly. Reattach the flash.
- You cannot use a flash with the following recording mode:
  - [Bracket: Cont.]
  - [Sweep Panorama]
  - [Night View] and [Hand-held Twilight] in [Scene Selection]
  - [Anti Motion Blur]
  - Movie recording

---

### Fuzzy white circular spots appear on images shot using the flash.

- Particles (dust, pollen, etc.) in the air reflected the flash light and appeared on the image. This is not a malfunction.

---

### The flash takes too long to recharge.

- The flash has been fired in succession in a short period. When the flash has been fired in succession, the recharging process may take longer than usual to avoid overheating of the camera.

---

**The image taken with the flash is too dark.**

- If the subject is beyond the flash range (the distance that the flash can reach), the pictures will be dark because the flash light does not reach the subject. If the ISO is changed, the flash range also changes with it.

---

**The date and time are recorded incorrectly.**

- Set the correct date and time (page 101).
- The area selected with [Area Setting] is different from the actual area. Set the actual area by selecting [Menu] → [Setup] → [Area Setting].

---

**The aperture value and/or shutter speed flashes when you press the shutter button halfway down.**

- Since the subject is too bright or too dark, it is beyond the available range of the camera. Adjust the setting again.

---

**The image is whitish (Flare).****Blurring of light appears on the image (Ghosting).**

- The picture was taken under a strong light source, and excessive light has entered the lens. When using the zoom lens, attach a lens hood.

---

**The corners of the picture are too dark.**

- If any filter or hood is used, take it off and try shooting again. Depending on the thickness of the filter and improper attachment of the hood, the filter or the hood may partially appear in the image. The optical properties of some lenses may cause the periphery of the image to appear too dark (insufficient light).

---

**The eyes of the subject come out red.**

- Activate the Red Eye Reduction function (page 88).
- Get close to the subject, and shoot the subject within the flash range using the flash.

---

**Dots appear and remain on the LCD monitor.**

- This is not a malfunction. These dots are not recorded.

---

**The image is blurred.**

- The picture was taken in a dark location without the flash, resulting in camera shake. The use of a tripod or the flash is recommended (page 31). [Hand-held Twilight] in [Scene Selection] (page 43) and [Anti Motion Blur] (page 45) are also effective in reducing blur.

---

**The exposure value is flashing on the LCD monitor.**

- The subject is too bright or too dark for the metering range of the camera.

## Viewing images

**Images cannot be played back.**

- The folder/file name has been changed on your computer.
- When an image file has been processed by a computer or when the image file was recorded using a model other than that of your camera, playback on your camera is not guaranteed.
- The camera is in USB mode. Delete the USB connection (page 131).
- Use "PMB" to play images stored on a computer with this camera.

## Deleting/Editing images

### The image cannot be deleted.

- Cancel the protection (page 83).

---

### The image was deleted by mistake.

- Once you have deleted an image, you cannot restore it. We recommend that you protect images that you do not want to delete (page 83).

---

### A DPOF mark cannot be put.

- You cannot mark DPOF marks on RAW images.

## Computers

### Not sure if the OS of the computer is compatible with the camera.

- Check "Recommended computer environment" (page 125).

---

### The computer does not recognize the camera.

- Check that the camera is turned on.
- When the battery level is low, install the charged battery pack, or use the AC Adaptor (sold separately).
- Use the USB cable (supplied) for connection.
- Disconnect the USB cable, and connect it again firmly.
- Set [USB Connection] to [Mass Storage] (page 110).
- Disconnect all equipment other than the camera, the keyboard and the mouse from the USB terminals of your computer.
- Connect the camera directly to your computer without passing through a USB hub or other device.

---

### Cannot copy images.

- Make the USB connection by properly connecting the camera with your computer (page 130).
- Follow the designated copy procedure for your OS.
- When you shoot images with a memory card formatted by a computer, you may not be able to copy the images to a computer. Shoot using a memory card formatted by your camera.

---

### Cannot play back images on a computer.

- If you are using "PMB," refer to the "PMB Help."
- Consult the computer or software manufacturer.

---

### The image and sound are interrupted by noise when viewing a movie on a computer.

- You are playing back the movie directly from the memory card. Import the movie to your computer using "PMB" and play it back.

---

### After making a USB connection, "PMB" does not start automatically.

- Make the USB connection after the computer is turned on (page 130).

## Memory card

### Cannot insert a memory card.

- Insertion direction of the memory card is wrong. Insert it in the correct direction.

### Cannot record on a memory card.

- The memory card is full. Delete unnecessary images (pages 28, 76).
- An unusable memory card is inserted.

### Formatted the memory card by mistake.

- All the data on the memory card is deleted by formatting. You cannot restore it.

## Printing

### Cannot print images.

- RAW images cannot be printed. To print RAW images first, convert them to JPEG images using “Image Data Converter SR” on the supplied CD-ROM.

### The color of the image is strange.

- When you print the images recorded in Adobe RGB mode using sRGB printers that are not compatible with Adobe RGB (DCF2.0/Exif2.21 or later), the images are printed at a lower saturation.

### Images are printed with both edges cut off.

- Depending on your printer, the left, right, top, and bottom edges of the image may be cut off. Especially when you print an image shot with the aspect ratio set to [16:9], the lateral end of the image may be cut off.
- When printing images using your own printer, cancel the trimming or borderless settings. Consult the printer manufacturer as to whether the printer provides these functions or not.
- When having images printed at a photo printing service shop, ask the shop whether they can print the images without cutting off both edges.

### Cannot print images with the date.

- Using “PMB,” you can print images with date.
- The camera does not have a feature for superimposing dates on images. However, because the images shot with the camera include information on the recording date, you can print images with the date superimposed if the printer or the software can recognize Exif information. For compatibility with Exif information, consult the manufacturer of the printer or the software.
- When you print images at a shop, images can be printed with the date if you ask them to do so.

## Others

### The lens gets fogged.

- Moisture condensation has occurred. Turn off the camera and leave it for about an hour before using it.

---

**The message “Set Area/Date/Time.” appears when the camera is turned on.**

- The camera has been left unused for sometime with a low battery or no battery pack. Charge the battery pack and set the date again (page 101). If the message appears every time you charge the battery pack, the internal rechargeable battery may be exhausted. Consult your Sony dealer or local authorized Sony service facility.

---

**The number of recordable images does not decrease, or decreases two at a time.**

- This is because the compression rate and the image size after compression change depending on the image when you shoot a JPEG image.

---

**The setting is reset without the resetting operation.**

- The battery pack was removed when the power switch was set to ON. When removing the battery pack, make sure the camera is turned off and the access lamp is not illuminated.

---

**The camera does not work properly.**

- Turn off the camera. Remove the battery pack and insert it again. If the camera is hot, remove the battery pack, and allow it to cool down before trying this corrective procedure.
- If an AC Adaptor (sold separately) is used, disconnect the power cord. Connect the power cord and turn on the camera again. If the camera does not work after doing these solutions, consult your Sony dealer or local authorized Sony service facility.

---

**“--E-” is indicated on the screen.**

- Remove the memory card, and insert it again. If this procedure does not turn off the indication, format the memory card (page 115).

# Warning messages

If the following messages appear, follow the instructions below.

---

## Incompatible battery. Use correct model.

- An incompatible battery pack is being used.

---

## Set Area/Date/Time.

- Set the date and time. If you have not used the camera for a long time, charge the internal rechargeable battery.

---

## Power insufficient

- You tried to clean the image sensor (Cleaning Mode) when the battery level is insufficient. Charge the battery pack or use an AC Adaptor (sold separately).

---

## Unable to use memory card. Format?

- The memory card was formatted on a computer and the file format was modified. Select [OK], then format the memory card. You can use the memory card again, however, all previous data in the memory card is erased. It may take some time to complete the format. If the message still appears, change the memory card.

---

## Memory Card Error

- An incompatible memory card is inserted or the format has failed.

---

## Reinsert memory card.

- The inserted memory card cannot be used in your camera.
- The memory card is damaged.
- The terminal section of the memory card is dirty.

---

## This memory card may not be capable of recording and playing normally.

- The inserted memory card cannot be used in the camera.

---

## Processing...

- Long exposure noise reduction will be done for the same amount of time that the shutter was open. You cannot do any further shooting during this reduction process. You can disable the long exposure noise reduction function.

---

## Unable to display.

- Images recorded with other cameras or images modified with a computer may not be able to be displayed.

---

## Cannot recognize lens. Attach it properly.

- The lens is not attached properly, or the lens is not attached. If the message appears when a lens is attached, reattach the lens. If the message appears frequently, check whether the contacts of the lens and camera are clean or not.
- When attaching the camera to an astronomical telescope or something similar, set [Release w/oLens] to [Enable] (page 95).

---

## No images

- There is no image on the memory card.

---

## Image protected

- You tried to delete protected images.

---

## Unable to print.

- You tried to mark RAW images with a DPOF mark.

---

## Camera overheating. Allow it to cool.

- The camera has become hot because you have been shooting continuously. Turn the power off. Cool the camera and wait until the camera is ready to shoot again.



- Since you have recorded movies for a long time, the camera temperature has risen. Stop recording movies.



- The SteadyShot function does not work. You can continue to shoot but the SteadyShot function will not work. Turn the camera off and on. If this icon does not disappear, consult your Sony dealer or local authorized Sony service facility.



- The number of images exceeds that for which date management in a database file by the camera is possible.



- Unable to register to the database file. Import all the images to a computer using “PMB” and recover the memory card.

---

## Camera Error

### System Error

- Turn the power off, remove the battery pack, then re-insert it. If the message appears frequently, consult your Sony dealer or local authorized Sony service facility.

---

## Image Database File error.

- There is something wrong occurred in the Image Database File. Select [Setup] → [Recover Image DB] → [OK].

---

## Image Database File error. Recover?

- You cannot record or play back AVCHD format movies because the Image Database File is damaged. Follow the on-screen instructions to recover data.

---

## Recording is unavailable in this movie format.

- Set [File Format] to [MP4].

---

**Unable to magnify.**

**Unable to rotate image.**

- Images recorded with other cameras may not be enlarged or rotated.

---

**No images selected.**

- You attempted to print without specifying images.

---

**No images changed.**

- You attempted to execute DPOF without specifying images.

---

**Cannot create more folders.**

- The folder with a name beginning with "999" exists on the memory card. You cannot create any folders if this is the case.

Table of  
contents

Sample photo  
search

Menu search

Index

# Using the camera abroad

You can use the battery charger (supplied), and the AC-PW20 AC Adaptor (sold separately) in any country or region where the power supply is within 100 V to 240 V AC, 50 Hz/60 Hz.

## Note

- Do not use an electronic transformer (travel converter), as this may cause a malfunction.

## On TV color systems

### NEX-5/5C

To view movies shot using this camera on a television, the camera and television must use the same color television system.

### NEX-3

The camera automatically detects the color system to match that of the connected video device.

### NTSC system (1080 60i)

Bahama Islands, Bolivia, Canada, Central America, Chile, Colombia, Ecuador, Jamaica, Japan, Korea, Mexico, Peru, Surinam, Taiwan, the Philippines, the U.S.A., Venezuela, etc.

### PAL system (1080 50i)

Australia, Austria, Belgium, China, Croatia, Czech Republic, Denmark, Finland, Germany, Holland, Hong Kong, Hungary, Indonesia, Italy, Kuwait, Malaysia, New Zealand, Norway, Poland, Portugal, Rumania, Singapore, Slovak Republic, Spain, Sweden, Switzerland, Thailand, Turkey, United Kingdom, Viet Nam, etc.

### PAL-M system (1080 50i)

Brazil

### PAL-N system (1080 50i)

Argentina, Paraguay, Uruguay

### SECAM system (1080 50i)

Bulgaria, France, Greece, Guiana, Iran, Iraq, Monaco, Russia, Ukraine, etc.

# Memory card



You can use following memory cards with this camera: “Memory Stick PRO Duo” media, “Memory Stick PRO-HG Duo” media, SD memory card, SDHC memory card, and SDXC memory card. You cannot use a MultiMedia Card.

## Notes

- Memory card formatted with a computer are not guaranteed to operate with the camera.
- Data read/write speeds differ depending on the combination of the memory card and the equipment used.
- Do not remove the memory card while reading or writing data.
- Data may be corrupted in the following cases:
  - When the memory card is removed or the camera is turned off during a read or write operation
  - When the memory card is used in locations subject to static electricity or electrical noise
- We recommend backing up important data, such as to a hard disk of a computer.
- Do not attach a label on the memory card itself nor on a memory card adaptor.
- Do not touch the terminal section of the memory card with your hand or a metal object.
- Do not strike, bend or drop the memory card.
- Do not disassemble or modify the memory card.
- Do not expose the memory card to water.
- Do not leave the memory card within the reach of small children. They might accidentally swallow it.
- The memory card may be hot just after it has been used for a long time. Be careful when you handle it.
- Do not use or store the memory card under the following conditions:
  - High temperature locations such as the hot interior of a car parked in direct sunlight
  - Locations exposed to direct sunlight
  - Humid locations or locations with corrosive substances present
- Images recorded on an SDXC memory card cannot be imported to or played on computers or AV devices that are not compatible with exFAT. Make sure that the device is compatible with exFAT before connecting it to the camera. If you connect your camera to an incompatible device, you may be prompted to format the card. Never format the card in response to this prompt, as doing so will erase all data on the card. (exFAT is the file system used on SDXC memory cards.)

## “Memory Stick” media

The types of “Memory Stick” media that can be used with the camera are listed in the table below. However, proper operation cannot be guaranteed for all “Memory Stick” media functions.

“Memory Stick PRO Duo” media <sup>*1*2*3</sup>	Available with your camera	
“Memory Stick PRO-HG Duo” media <sup>*1*2</sup>		
“Memory Stick Duo” media	Unavailable with your camera	
“Memory Stick” media and “Memory Stick PRO” media	Unavailable with your camera	

<sup>\*1</sup> This is equipped with MagicGate function. MagicGate is copyright protection technology that uses encryption technology. Data recording/playback that requires MagicGate functions cannot be performed with this camera.

<sup>\*2</sup> Supports high-speed data transfer using a parallel interface.

<sup>\*3</sup> When using “Memory Stick PRO Duo” media to record movies, only those marked with Mark2 can be used.

### Notes on using “Memory Stick Micro” media (sold separately)

- This product is compatible with “Memory Stick Micro” media (“M2”). “M2” is an abbreviation for “Memory Stick Micro” media.
- To use a “Memory Stick Micro” media with the camera, be sure to insert the “Memory Stick Micro” media into an “M2” Adaptor as large as of Duo size. If you insert a “Memory Stick Micro” media into the camera without an “M2” Adaptor as large as of Duo size, you might not be able to remove it from the camera.
- Do not leave the “Memory Stick Micro” media within the reach of small children. They might accidentally swallow it.

# “InfoLITHIUM” battery pack

Your camera operates only with an “InfoLITHIUM” battery pack NP-FW50. You cannot use any other battery packs. “InfoLITHIUM” W series battery packs have the  mark.

An “InfoLITHIUM” battery pack is a lithium-ion battery pack that has functions for communicating information related to operating conditions with the camera. The “InfoLITHIUM” battery pack calculates the power consumption according to the operating conditions of your camera, and displays the remaining battery time in percentages.

## On charging the battery pack

We recommend charging the battery pack in an ambient temperature of between 10 °C to 30 °C (50 °F to 86 °F). The battery pack may not be effectively charged in temperatures outside this range.

## Effective use of the battery pack

- Battery performance decreases in low temperature surroundings. So in cold places, the operational time of the battery pack is shorter. To ensure longer battery pack use, we recommend putting the battery pack in a pocket close to your body to warm it up, and insert it in the camera immediately before you start shooting.
- The battery pack will run out quickly if you use the flash or record movies frequently.
- We recommend having spare battery packs handy and making trial shots before taking the actual shots.
- Do not expose the battery pack to water. The battery pack is not water-resistant.
- Do not leave the battery pack in extremely hot places, such as in a car or under direct sunlight.

## On the remaining battery time indicator

When the power goes off even though the remaining battery time indicator indicates that the battery pack has enough power to operate, charge the battery pack again. Remaining battery time will be indicated correctly. Note, however, that the battery indication will not be restored if it is used in high temperatures for a long time, or if left after being charged, or when the battery pack is frequently used. Use the remaining battery indication as a rough guide only.

## How to store the battery pack

- Fully discharge the battery pack before storing and store it in a cool, dry place. To maintain the battery pack’s function, charge the battery pack and then fully discharge it on the camera at least once a year.
- To use the battery pack up, leave the camera in slide show playback mode until the power goes off.
- To prevent staining the terminal, short-circuiting, etc., be sure to use a plastic bag to keep away from metal materials when carrying or storing the battery pack.

## On battery life

- The battery life is limited. Battery capacity decreases over time and through repeated use. If decreased usage time between charges becomes significant, it is probably time to replace it with a new one.
- The battery life varies according to how it is stored and the operating conditions and environment in which each battery pack is used.

Table of contents

Sample photo search

Menu search

Index

# Battery charger

- Only NP-FW type battery packs (and no others) can be charged in the battery charger (supplied). Batteries other than the specified kind may leak, overheat, or explode if you attempt to charge them, posing a risk of injury from electrocution and burns.
- Remove the charged battery pack from the battery charger. If you leave the charged battery pack in the charger, battery life may be shortened.
- The CHARGE lamp of the supplied battery charger flashes in either way:  
Fast flashing: Turns the light on and off repeatedly at the interval of 0.15 seconds.  
Slow flashing: Turns the light on and off repeatedly at the interval of 1.5 seconds.
- When the CHARGE lamp flashes fast, remove the battery pack being charged, and then insert the same battery pack into the battery charger securely again. When the CHARGE lamp flashes fast again, this may indicate a battery error or that a battery pack other than the specified type has been inserted. Check that the battery pack is the specified type. If the battery pack is the specified type, remove the battery pack, replace it with a new one or another one and check if the battery charger operates correctly. If the battery charger operates correctly, a battery error may have occurred.
- When the CHARGE lamp flashes slowly, it indicates that the battery charger stops charging temporarily on standby. The battery charger stops charging and enters the standby status automatically when the temperature is outside of the recommended operating temperature. When the temperature gets back within the appropriate range, the battery charger resumes charging and the CHARGE lamp lights up again. We recommend charging the battery pack in an ambient temperature of between 10 °C to 30 °C (50 °F to 86 °F).
- If the battery charger is dirty, batteries may not be charged correctly. Clean the battery charger with dry cloth, etc.

Table of contents

Sample photo search

Menu search

Index

# Mount Adaptor

Using the Mount Adaptor LA-EA1 (sold separately), you can attach an A-mount lens to your camera. For details, refer to the operating instructions supplied with the Mount Adaptor.

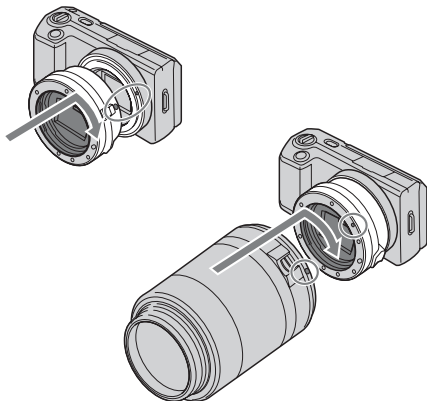

## Notes

- You may not be able to use the Mount Adaptor with certain lenses. Consult your Sony dealer or local authorized Sony service facility on compatible lenses.
- The continuous shooting speed of still images will be slower.

# AVCHD format (NEX-5/5C)

The AVCHD format is a high definition digital video camera format used to record a high definition (HD) signal of either the 1080i specification<sup>\*1</sup> or the 720p specification<sup>\*2</sup> using efficient data compression coding technology. The MPEG-4 AVC/H.264 format is adopted to compress video data, and the Dolby Digital or Linear PCM system is used to compress audio data.

The MPEG-4 AVC/H.264 format is capable of compressing images at higher efficiency than that of the conventional image compressing format. The MPEG-4 AVC/H.264 format enables a high definition video signal shot on a digital video camera recorder to be recorded on 8 cm DVD discs, hard disk drive, flash memory, memory card, etc.

## Recording and playback on your camera

Based on the AVCHD format, your camera records with the high definition image quality (HD) mentioned below.

Video signal<sup>\*3</sup>: **1080 60i-compatible device**  
MPEG-4 AVC/H.264 1920 × 1080/60i  
**1080 50i-compatible device**  
MPEG-4 AVC/H.264 1920 × 1080/50i

Audio signal: Dolby Digital 2ch

Recording media: Memory card

<sup>\*1</sup> 1080i specification

A high definition specification which utilizes 1,080 effective scanning lines and the interlace system.

<sup>\*2</sup> 720p specification

A high definition specification which utilizes 720 effective scanning lines and the progressive system.

<sup>\*3</sup> Data recorded in AVCHD format other than the above mentioned cannot be played on your camera.

# Cleaning

## Cleaning the camera

- Do not touch the inside of the camera, such as lens contacts. Blow away dust from inside the mount using a commercially available blower\*. For details on cleaning the image sensor, see page 111.
  - \* Do not use a spray blower. Using one may cause a malfunction.
- Clean the camera surface with a soft cloth slightly moistened with water, then wipe the surface with a dry cloth. Do not use the following as they may damage the finish or the casing.
  - Chemical products such as thinner, benzene, alcohol, disposable cloths, insect repellent, sunscreen or insecticide, etc.
  - Do not touch the camera with the above on your hand.
  - Do not leave the camera in contact with rubber or vinyl for a long time.

## Cleaning the lens

- Do not use a cleaning solution containing organic solvents, such as thinner, or benzene.
- When cleaning the lens surface, remove dust using a commercially available blower. In case of dust that sticks to the surface, wipe it off with a soft cloth or tissue paper slightly moistened with lens cleaning solution. Wipe in a spiral pattern from the center to the outside. Do not spray lens cleaning solution directly onto the lens surface.

# Index

## A

AdobeRGB .....	93
AF Illuminator .....	87
AF/MF Select .....	53
Anti Motion Blur .....	45
Aperture .....	51
Aperture Priority .....	51
Area Setting .....	102
Aspect Ratio .....	65
Auto HDR .....	74
Auto Review .....	89
Autoflash .....	31
Autofocus .....	53
Autofocus Area .....	55
Autofocus Mode .....	56
AVCHD .....	67, 153

## B

Beep .....	99
Bracket: Cont. ....	38
“BRAVIA” Sync .....	124
BULB .....	49

## C

Center .....	55, 71
Cleaning Mode .....	111
Color filter .....	70
Color Space .....	93
Color Temperature .....	70
Computer .....	125
Recommended environment .....	125
Connection .....	
Computer .....	130
TV .....	123
Continuous Adv. ....	34
Contrast .....	75
Control wheel .....	17
CTRL FOR HDMI .....	109
Custom white balance .....	70

## D

Date Format .....	101
Date/Time Setup .....	101

Daylight Svg. ....	101
Defocusing the background .....	24
Delete .....	28, 76
Demo Mode .....	113
Direct Manual Focus .....	53
Disc creation .....	132
DISP .....	29
Display Card Space .....	121
Display Color .....	106
Display Contents .....	29
DMF .....	53
DPOF .....	86
D-Range Opt. ....	73
Drive Mode .....	33
DRO/Auto HDR .....	73

## E

Enlarge Image .....	84
Enlarged playback .....	26
Exposure Comp. ....	32
Eye-Fi card .....	122

## F

Face Detection .....	58
File Format .....	67
File Number .....	116
Fill-flash .....	31
Flash .....	31
Flash Compensation .....	72
Flash Mode .....	31
Flash Off .....	31
Flexible Spot .....	55
Folder Name .....	117
Format .....	115

## G

Grid Line .....	90
-----------------	----

## H

Hand-held Twilight .....	44
Help Guide Display .....	103
High ISO NR .....	97
Histogram .....	91

**I**

Icons .....	15
Identifying parts .....	11
Image Data Converter SR .....	128
Image Data Lightbox SR .....	129
Image Index .....	40, 79
Image Size .....	63
“InfoLITHIUM” battery pack .....	149
Install .....	127
Intelligent Auto .....	24, 41
ISO .....	68

**J**

JPEG .....	66
------------	----

**L**

Landscape .....	43
Language .....	100
LCD Brightness .....	105
Long Exposure NR .....	96

**M**

Macintosh .....	128
Macro .....	43
Manual Exposure .....	48
Manualfocus .....	53
Memory card .....	147
Menu .....	19
Brightness/Color .....	20
Camera .....	20
Image Size .....	20
Playback .....	21
Setup .....	21
Shoot Mode .....	19
Metering Mode .....	71
MF Assist .....	92
Movie Audio Rec .....	98
MP4 .....	67
Multi .....	55, 71

**N**

New Folder .....	119
Night Portrait .....	43
Night View .....	43

**P**

Panorama .....	46
Panorama Direction .....	61
Playback .....	26
Playback Display .....	108
Playback on TV .....	123
Playback zoom .....	26
PMB .....	129
PMB Launcher .....	127
Portrait .....	43
Power Save .....	104
Precision Dig. Zoom .....	57
Preset white balance .....	70
Print .....	136
Program Auto .....	52
Protect .....	83

**Q**

Quality .....	66
---------------	----

**R**

RAW .....	66
Rear Sync. ....	31
Recover Image DB .....	120
Red Eye Reduction .....	88
Release w/oLens .....	95
Remote Cdr. ....	39
Reset Default .....	114
Rotate .....	82

**S**

Saturation .....	75
Scene Recognition .....	23, 41
Scene Selection .....	43
Scroll playback .....	47
Select Date .....	81
Select Folder .....	80
Select Shoot. Folder .....	118
Self-timer .....	36
Self-timer(Cont.) .....	37
Setup .....	21
Sharpness .....	75
Shooting .....	23
Movie .....	23
Still image .....	23
Shooting Tip List .....	62

Shutter Priority .....	50
Shutter speed .....	50
Single-shot AF .....	56
Slide Show .....	77
Slow Sync. ....	31
Smile Detection .....	60
Smile Shutter .....	59
Soft keys .....	18
Specify Printing .....	86
Speed Priority Cont. ....	35
Sports Action .....	43
Spot .....	71
sRGB .....	93
SteadyShot .....	94
Still/Movie Select .....	78
Sunset .....	43
Sweep Panorama .....	46

## T

Troubleshooting .....	137
-----------------------	-----

## U

Upload Settings .....	122
USB Connection .....	110

## V

Version .....	112
Volume Settings .....	85

## W

Warning messages .....	143
White Balance .....	69
Wide Image .....	107
Windows .....	127

## Notes on the License

“C Library”, “Expat”, “zlib”, “dtoa”, “pcre”, and “libjpeg” software are provided in the camera. We provide this software based on license agreements with their owners of copyright. Based on requests by the owners of copyright of these software applications, we have an obligation to inform you of the following. Please read the following sections. Read “license1.pdf” in the “License” folder on the CD-ROM. You will find licenses (in English) of “C Library”, “Expat”, “zlib”, “dtoa”, “pcre” and “libjpeg” software.

NEX-5/5C IS LICENSED UNDER THE AVC PATENT PORTFOLIO LICENSE FOR THE PERSONAL AND NON-COMMERCIAL USE OF A CONSUMER TO

(i) ENCODE VIDEO IN COMPLIANCE WITH THE AVC STANDARD (“AVC VIDEO”)

AND/OR

(ii) DECODE AVC VIDEO THAT WAS ENCODED BY A CONSUMER ENGAGED IN A PERSONAL AND NON-COMMERCIAL ACTIVITY AND/OR WAS OBTAINED FROM A VIDEO PROVIDER LICENSED TO PROVIDE AVC VIDEO. NO LICENSE IS GRANTED OR SHALL BE IMPLIED FOR ANY OTHER USE. ADDITIONAL INFORMATION MAY BE OBTAINED FROM MPEG LA, L.L.C. SEE

[HTTP://WWW.MPEGLA.COM](http://www.mpegla.com)

NEX-3 IS LICENSED UNDER THE MPEG-4 VISUAL PATENT PORTFOLIO LICENSE FOR THE PERSONAL AND NON-COMMERCIAL USE OF A CONSUMER FOR

(i) ENCODING VIDEO IN COMPLIANCE WITH THE MPEG-4 VISUAL STANDARD (“MPEG-4 VIDEO”)

AND/OR

(ii) DECODING MPEG-4 VIDEO THAT WAS ENCODED BY A CONSUMER ENGAGED IN A PERSONAL AND NON-COMMERCIAL ACTIVITY AND/OR WAS OBTAINED FROM A VIDEO PROVIDER LICENSED BY MPEG LA TO PROVIDE MPEG-4 VIDEO.

NO LICENSE IS GRANTED OR SHALL BE IMPLIED FOR ANY OTHER USE. ADDITIONAL INFORMATION INCLUDING THAT RELATING TO PROMOTIONAL, INTERNAL AND COMMERCIAL USES AND LICENSING MAY BE OBTAINED FROM MPEG LA, LLC. SEE

[HTTP://WWW.MPEGLA.COM](http://www.mpegla.com)

## On GNU GPL/LGPL applied software

The software that is eligible for the following GNU General Public License (hereinafter referred to as “GPL”) or GNU Lesser General Public License (hereinafter referred to as “LGPL”) are included in the camera.

This informs you that you have a right to have access to, modify, and redistribute source code for these software programs under the conditions of the supplied GPL/LGPL.

Source code is provided on the web. Use the following URL to download it.

<http://www.sony.net/Products/Linux/>

We would prefer you do not contact us about the contents of source code.

Read “license2.pdf” in the “License” folder on the CD-ROM. You will find licenses (in English) of “GPL”, and “LGPL” software.

To view the PDF, Adobe Reader is needed. If it is not installed on your computer, you can download it from the Adobe Systems web page:

<http://www.adobe.com/>

Table of contents

Sample photo search

Menu search

Index