

# [POWER COMMANDER V]

## 2013 Kawasaki ZX-6R

### Installation Instructions



#### PARTS LIST

- 1 Power Commander
- 1 USB Cable
- 1 CD-ROM
- 1 Installation Guide
- 2 Power Commander Decals
- 2 Dynojet Decals
- 2 Velcro Strip
- 1 Alcohol Swab
- 1 Posi-tap

**THE IGNITION MUST BE TURNED OFF BEFORE INSTALLATION!**

YOU CAN ALSO DOWNLOAD THE POWER COMMANDER SOFTWARE AND LATEST MAPS FROM OUR WEB SITE AT:  
[www.powercommander.com](http://www.powercommander.com)

**PLEASE READ ALL DIRECTIONS BEFORE STARTING INSTALLATION**

**Dynojet**

2191 Mendenhall Drive North Las Vegas, NV 89081 (800) 992-4993 [www.powercommander.com](http://www.powercommander.com)

# POWER COMMANDER V INPUT ACCESSORY GUIDE

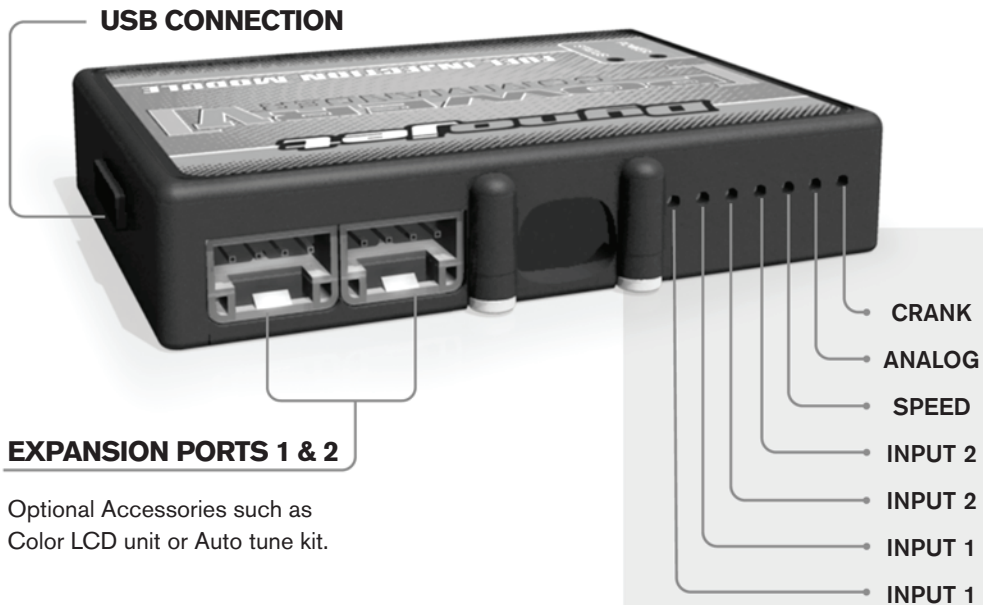

## Wire connections:

To input wires into the PCV first remove the rubber plug on the backside of the unit and loosen the screw for the corresponding input. Using a 22-24 gauge wire strip about 10mm from its end. Push the wire into the hole of the PCV until it stops and then tighten the screw. Make sure to reinstall the rubber plug.

NOTE: If you tin the wires with solder it will make inserting them easier.

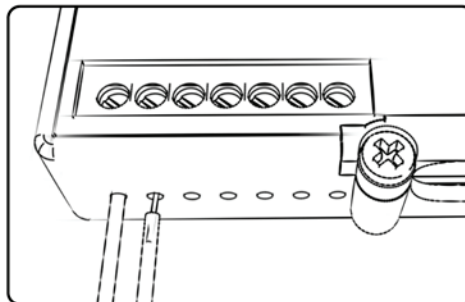

## ACCESSORY INPUTS

### Map -

(Input 1 or 2) The PCV has the ability to hold 2 different base maps. You can switch on the fly between these two base maps when you hook up a switch to the MAP inputs. You can use any open/close type switch. The polarity of the wires is not important. When using the Autotune kit one position will hold a base map and the other position will let you activate the learning mode. When the switch is "CLOSED" Autotune will be activated.

### Shifter-

(Input 1 or 2) These inputs are for use with the Dynojet quickshifter. Insert the wires from the Dynojet quickshifter into the SHIFTER inputs. The polarity of the wires is not important.

### Speed-

If your application has a speed sensor then you can tap into the signal side of the sensor and run a wire into this input. This will allow you to calculate gear position in the Control Center Software. Once gear position is setup you can alter your map based on gear position and setup gear dependent kill times when using a quickshifter.

### Analog-

This input is for a 0-5v signal such as engine temp, boost, etc. Once this input is established you can alter your fuel curve based on this input in the control center software.

### Crank-

Do **NOT** connect anything to this port unless instructed to do so by Dynojet. It is used to transfer crank trigger data from one module to another.

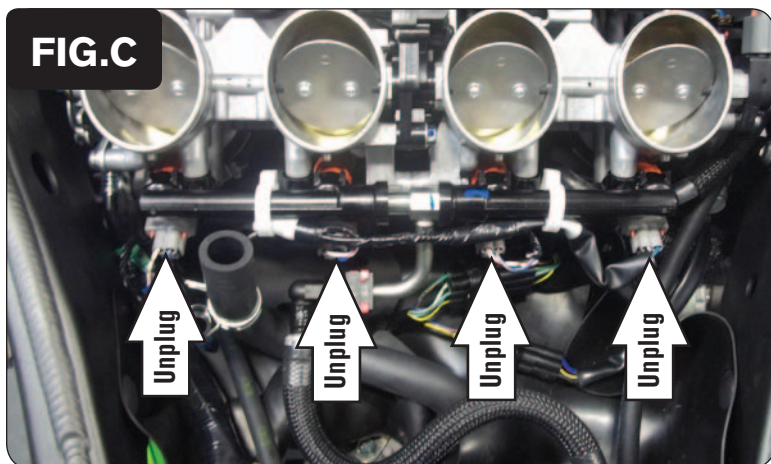
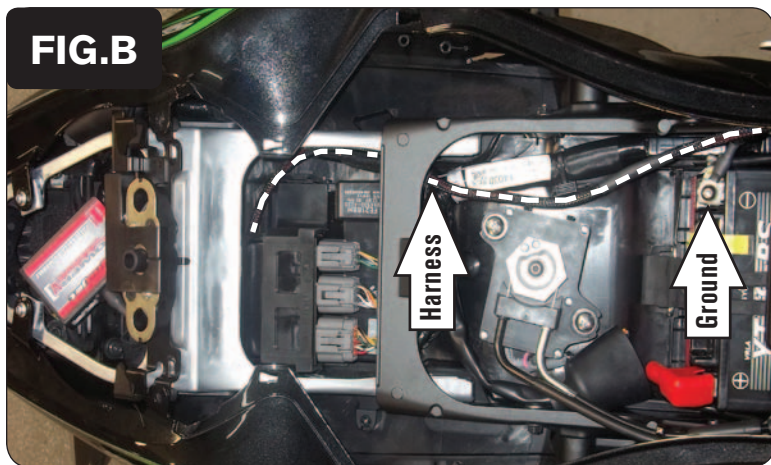
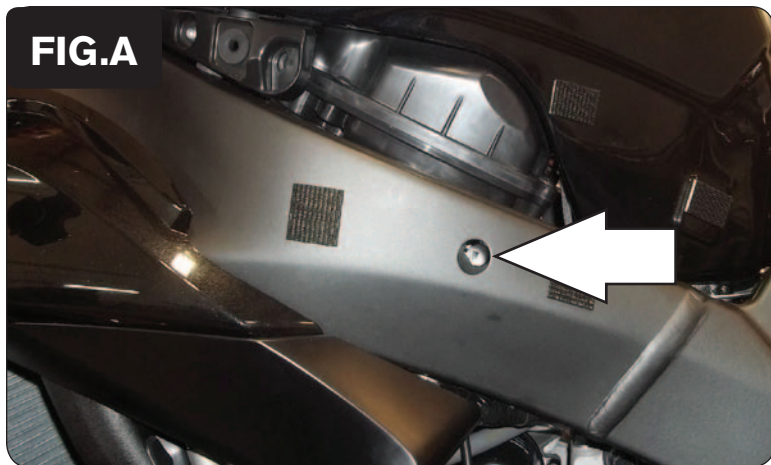

- 1 Remove the main seat and the passenger seat.
- 2 Remove the plastic covers from both sides of the fuel tank.
- 3 Remove the fuel tank.
- 4 Remove the airbox.

*The bottom clamps of the airbox can be loosened by accessing them through the hole in the frame (Fig. A).*

- 5 Using the supplied Velcro, secure the PCV in the tail section (Fig. B).  
*Be sure to clean both surfaces with the supplied alcohol swab prior to applying the Velcro.*
- 6 Route the PCV wiring harness towards the throttle bodies down the left hand side of the bike.
- 7 Secure the ground wire with the 6mm ring lug of the PCV wiring harness to the negative terminal of the bike's battery (Fig. B).

- 8 Unplug the stock wiring harness from each of the fuel injectors (Fig. C).



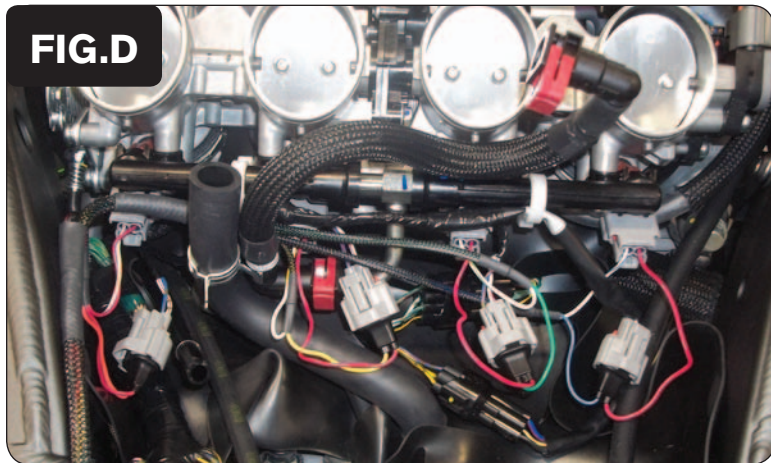

- 9 Plug the PCV wiring harness in-line of the fuel injector and the stock wiring harness (Fig. D).

*The pair of PCV injector leads with ORANGE colored wires plug in-line of the #1 cylinder fuel injector.*

*The pair of PCV injector leads with YELLOW colored wires plug in-line of the #2 cylinder fuel injector.*

*The pair of PCV injector leads with GREEN colored wires plug in-line of the #3 cylinder fuel injector.*

*The pair of PCV injector leads with BLUE colored wires plug in-line of the #4 cylinder fuel injector.*

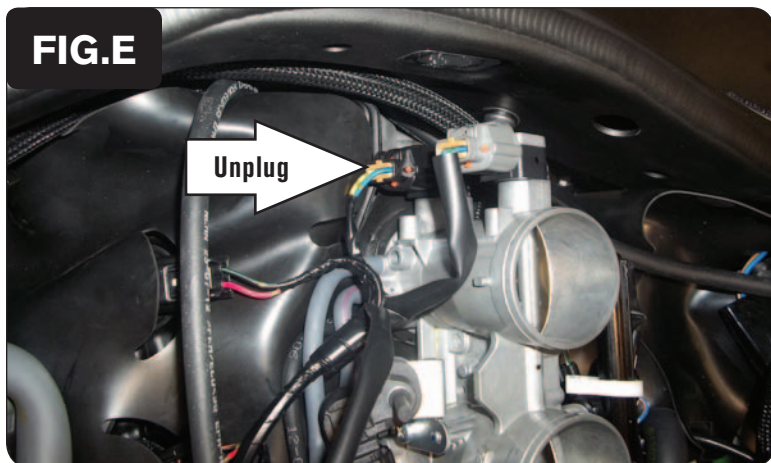

- 10 Locate and unplug the stock wiring harness from the bike's primary Throttle Position Sensor on the right hand side of the throttle bodies (Fig. E).

*This is the lower TPS with the BLACK connector; NOT the upper TPS with the GREY connector.*



- 11 Plug the PCV wiring harness in-line of the primary TPS and the stock wiring harness (Fig. F).

**FIG.G**

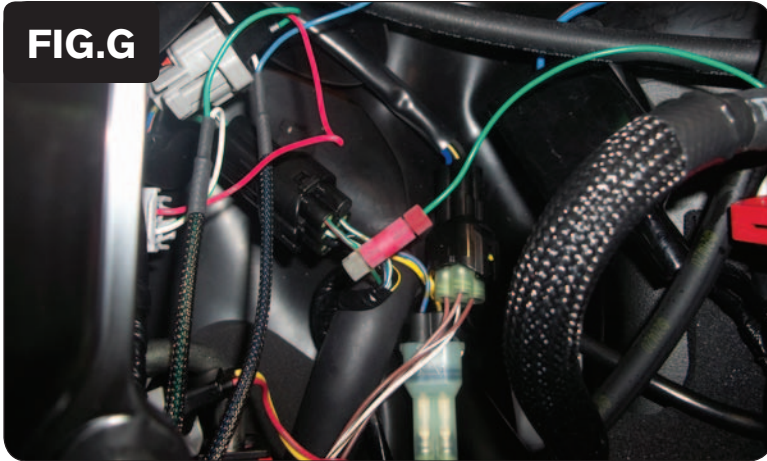

- 12 Use the supplied Posi-tap to attach the BLUE/WHITE wire of the PCV wiring harness to the stock GREEN/RED wire of the bike's Gear Position Sensor (Fig. G).

*This GREEN/RED wire is on a BLACK 6-pin connector located under the #3 and #4 primary fuel injectors.*

*This gear input connection is only required if using gear dependent features of the PCV, such as Gear Dependent mapping, Gear Dependent Quickshifter kill times, or viewing the live Gear Position gauge from the computer software or LCD accessory.*

