



MOUNTING INSTRUCTIONS

2321-0036 Kawasaki Vulcan 900 Classic Fats/Slims Mounting Kit - 06

! WARNING

Read and follow these directions carefully.

During installation, make certain that when turning the forks, there can be no interference with wiring or cables AND, that the windshield can not hit the gas tank, through the windshield's full range of adjustment.

This is a detachable windshield, **ALWAYS** make sure the Locking Mechanism is Fully Engaged after installing the windshield!

The improper installation of this kit and related components could result in serious injury or death.

Additional tools required that are not included in this kit. 7/16" or 11mm Wrench, 12mm and 14mm deep well sockets and ratchet.

1. **Cover gas tank and front fender with towels to avoid damage during installation.**
2. Install the two mounting plates onto the windshield, using the bottom and third bolt up. Leave the nylon washers off. The small tab goes to the bottom, big one at the top. *Tabs point out towards the edge of the Windshield.* (see fig. 1)
3. Remove and retain the two nuts that hold the Headlight to the Lower Triple Tree. Place a protective cloth over the Turn Signal Bar. Lift the Headlight and allow it to hang over the Turn Signal Bar. (see figure 2)
4. Remove and retain the two nuts that hold the Handlebar Risers to the upper Triple Tree. Pull the Wire Loom Bracket away from the Riser Bolts. Slip the upper bracket on to the bolts followed by the wire loom. Re-install and tighten the Riser Nuts. (See Figure 2)
5. Loosen the Allen bolts on upper bracket and slip the left and right side bracket into the upper bracket and loosely tighten. "To be tightened later, see step 8"
6. Re-install the Headlight through the lower holes in the left and right side bracket and through the lower triple tree. Re-install and tighten Headlight Bolts.

7. Install the windshield by placing the lower slots into the lower mounting bushings. Slip the upper slots into the upper mounting bushings and gently but firmly seat the slots into place. Lock the locking mechanism into place. (see figure 3)

8. Loosen the upper Allen bracket mounting bolts and re-tighten.

9. Adjust the height, angle and alignment of the windshield and tighten **ALL** bolts.

Note: This is a detachable windshield, ALWAYS make sure the Locking Mechanism is Fully Engaged after installing the windshield! (see figure 3)

CAUTION

IMPORTANT CARE AND CLEANING INSTRUCTIONS

Memphis Shades Windshields and Lowers are made of Lucite® acrylic, and will last for years with proper care. Clean your windshield with plenty of soapy water — mild dishwashing liquid is best — and a soft cotton cloth. Use your bare hand to feel and dislodge bugs, or cover with a wet soapy towel and let it soak. Don't use paper towels and don't scrape with anything. Small scratches can be removed with NOVUS # 2.

NEVER use any glass cleaning products, petroleum based chemicals, or cleaning agents with ammonia, bleach or any other harsh chemicals. This includes (but not limited to) RainX, brake fluid, acetone, paint thinner, benzene and gasoline. "If it hurts your nose, it will hurt the plastic."

Glass cleansing agents will cause severe damage

NOTE: At certain times of the day the Sunlight can reflect off the curvature of a windshield and cause extreme heat build-up on motorcycle instruments and instrument panel. Take care when parking. Park facing the sun, place an opaque object over the instruments or adjust the windshield to avoid reflections.

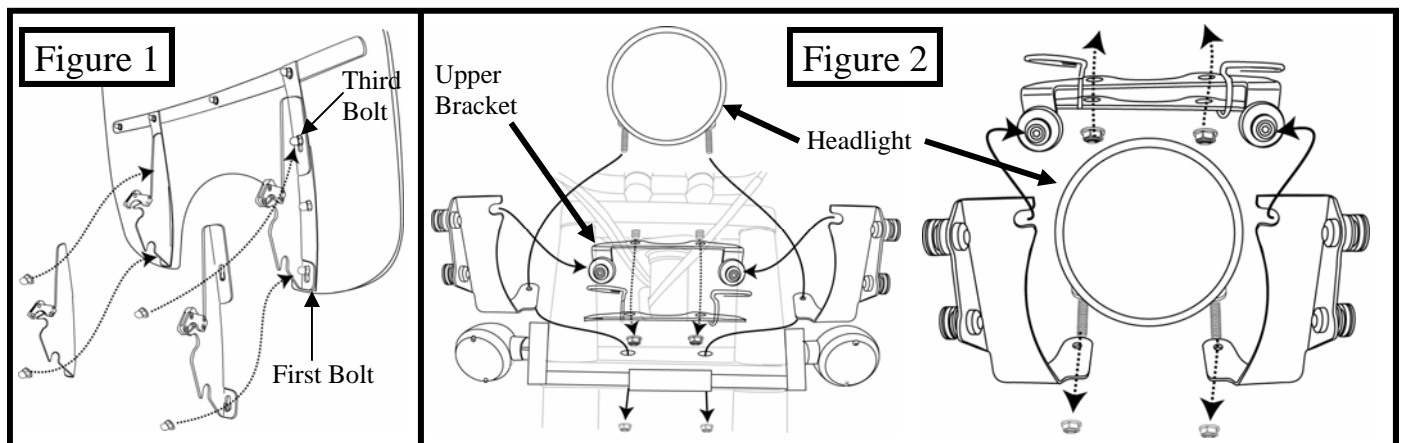



MOUNTING INSTRUCTIONS

2321-0036 Kawasaki Vulcan 900 Classic Fats/Slims Mounting Kit - 06

PART #	DESCRIPTION	QTY.
M8962	MOUNTING INSTRUCTIONS	1
M1105	LEFT MOUNTING PLATE FATS/SLIMS	1
M1104	RIGHT MOUNTING PLATE FATS/SLIMS	1
M1101	LEFT BRACKET KAWASAKI VUL 900 C	1
M1100	RIGHT BRACKET KAWASAKI VUL 900 C	1
M1099	UPPER BRACKET KAWASAKI VUL 900 C	1
R318	1" SOCKET SHOULDER WASHER	4
R323	BUSHING ASSEMBLY (2 PART)	4
R324	#207 EPDM O-RING	4
M303	1/4"-20 X 3/4" SOCKET HEAD CAP SCREW	4
M505	BUTTON NUT	6
R321	1" RECESSED SPACER WASHER	4

PART #	DESCRIPTION	QTY.
R322C	CLUTCH SIDE LATCH ASSEMBLY	1
R322T	THROTTLE SIDE LATCH ASSEMBLY	1
R334	6-32 X 3/8" FLAT HEAD SS SCREW	8
R326	SS SPRING	2
R327	1-1/4" RECESSED SUPPORT WASHER	2
M306	1/4"-20 X 5/8" SOCKET HEAD CAP SCREW	2
M501	BEVELED SOCKET WASHER	2
M310	3/16" SHORT ARM ALLEN WRENCH	1
M313	3/16" ALLEN WRENCH COVER	1

Figure 3

