



MOUNTING INSTRUCTIONS



2321-0100 MOUNTING KIT HONDA VT 1100 SABRE/VT 750 ACE DLX, BLACK

! WARNING

Read and follow these directions carefully.

During installation, make sure that the fairing and hardware do not interfere with any cables or wiring when the forks are turned all the way in either direction. Also make sure, through the full range of adjustment, that the fairing and hardware do not hit the tank.

This is a detachable fairing, **ALWAYS** make sure the Locking Mechanism is Fully Engaged after installing the fairing! The improper installation of this kit and related components could result in serious injury or death.

Additional tools required that are not included in this kit. 7/16" or 11mm, 8mm Wrench, or 1/4 sockets and ratchet.

1. Cover gas tank and front fender with towels to avoid damage during installation.
2. Install the plates onto the fairing using the washers and acorn nuts provided. (Fig 1)
3. Remove the Allen Screw, Socket Shoulder Washer and slot nut from both sides of the lower bracket. Set them off to the side, they will be used later to join the upper bracket to the lower bracket. Using an 8mm wrench, remove the two bolts that hold the turn signal bar in place, slip the lower fairing mounting bracket behind the turn signal bar (see figure 2, the headlight is not shown for clarification.) and re-install the bolts. **The tabs on the lower fairing bracket should be turned up and facing towards the forks.**
4. Using the 6mm Allen wrench provided, remove the original upper triple tree pinch bolt on the throttle side. Install the L-shaped upper bracket assembly and loosely tighten it, use the new longer bolts with spacers that are provided. Now insert the Allen Screw into the Socket Shoulder washer, insert them into the upper bracket then into the lower bracket. (Continued)

(4. Continued) Now install and loosely tighten the slot nut to join the upper and lower bracket. (see figure 2, the headlight is not shown for clarification.) **Tighten these bolts after the fairing has been installed. Repeat step 4 on the clutch side.**

5. Slip the fairing mounting plates and fairing onto the upper and lower bushing assemblies, (see figure 3) and secure the left and right side locking mechanism.

6. Adjust the height, angle and alignment of the fairing and tighten **ALL** bolts.

CAUTION

IMPORTANT CARE AND CLEANING INSTRUCTIONS

Memphis Shades Fairings and Loweres are made of Lucite® acrylic, and will last for years with proper care. Clean your fairing with plenty of soapy water — mild dishwashing liquid is best — and a soft cotton cloth. Use your bare hand to feel and dislodge bugs, or cover with a wet soapy towel and let it soak. Don't use paper towels and don't scrape with anything. Small scratches can be removed with NOVUS # 2.

NEVER use any glass cleaning products, petroleum based chemicals, or cleaning agents with ammonia, bleach or any other harsh chemicals. This includes (but not limited to) RainX, brake fluid, acetone, paint thinner, benzene and gasoline. "If it hurts your nose, it will hurt the plastic."

Glass cleansing agents will cause severe damage to your fairing, and will void your warranty.

NOTE: At certain times of the day the Sunlight can reflect off the curvature of a fairing and cause extreme heat build-up on motorcycle instruments and instrument panel. Take care when parking. Park facing the sun, place an opaque object over the instruments or adjust the fairing to avoid reflections.

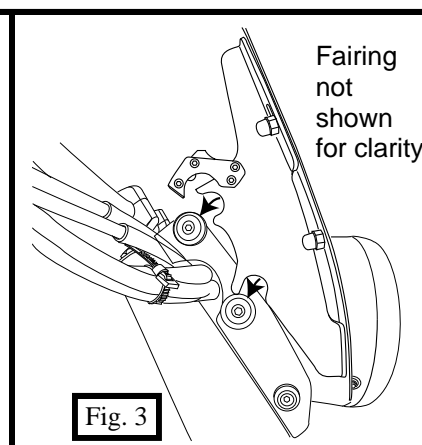
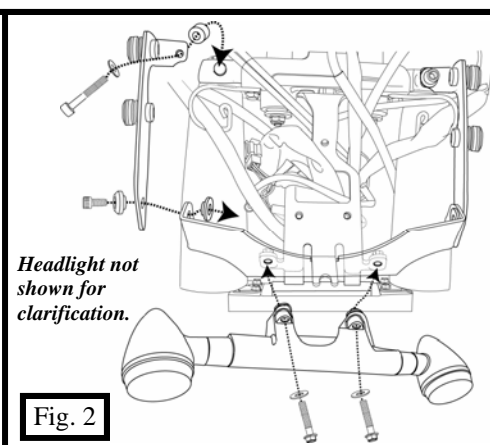
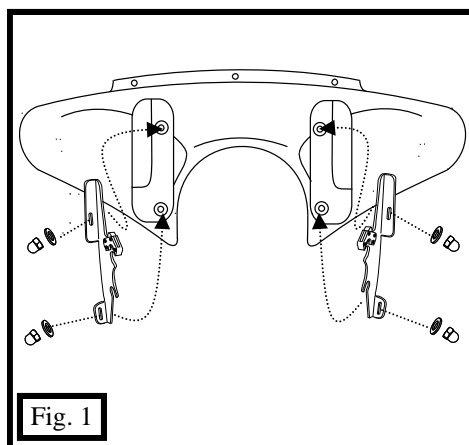



MOUNTING INSTRUCTIONS



2321-0100 MOUNTING KIT HONDA VT 1100 SABRE/VT 750 ACE DLX, BLACK

Part #	Description	Qty	Part #	Description	Qty
M8991	Mounting Instructions	1	M301	1/4"-20x3/8" SS Socket head cap screw	2
M1244	Clutch side mounting plate, black	1	R329	Slot nut	2
M1245	Throttle side mounting plate, black	1	M320	8mmx45mm SS Socket head cap screw	2
M1151	Left bracket	1	M321	5/16" SS washer	2
M1152	Right bracket	1	M591	Pinch bolt spacer	2
M1157	Lower bracket	1	M578	Self adhesive plastic washer	2
R323	Bushing assembly (2 part)	4	R322C/T	Latch assembly	2
R324	#207 EPDM O ring	4	R326	Latch spring	2
M306	1/4"-20x5/8" SS Socket head cap screw	4	R334	Latch screw	8
R318	1" Socket shoulder washer	4	R341	6mm Long arm allen wrench	1
R321	1" Recessed spacer washer	4	M310	3/16" short arm allen wrench	1
M505	Button nut	4	M313	3/16" allen wrench cover	1
M501	Beveled socket washer	2			

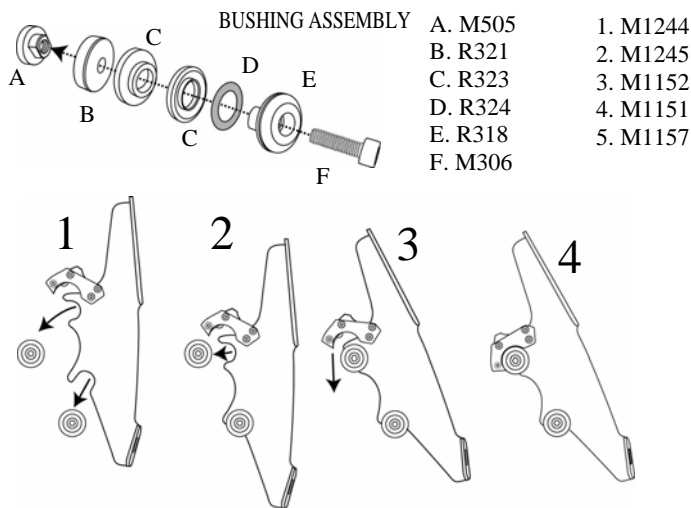

1. Place lower slot into lower bushing. 2. Rotate top slot into place. 3. & 4. Secure locking Mechanism.

Fig. 4

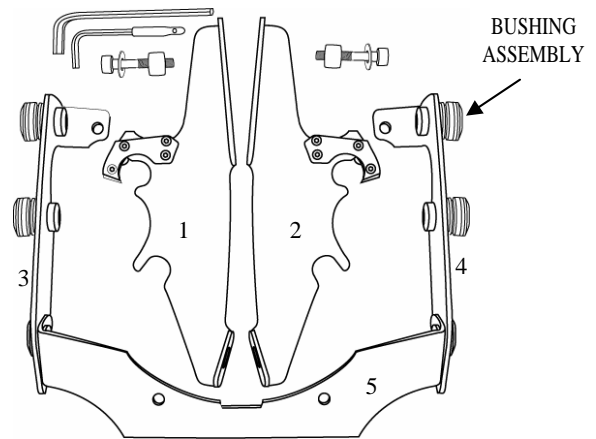

2321-0059 FATS/SLIMS KIT

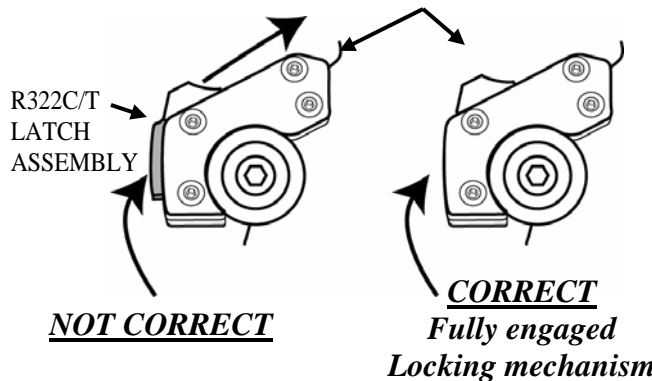

Memphis Shades warrants all product components, metal and plastic, against defects in materials and workmanship for 24 months.

FOR PARTS AND WARRANTY HELP, CONTACT:

MEMPHIS SHADES
P. O. Box 429
Rossville, TN 38066
(901) 853-0293

Visit us on the web at www.memphisshades.com or you can also reach us at customerservice@memphisshades.com