



Part No. 2321-0155

K1923 121109

**Metric Batwing Fairing Mounting Kit.
Kawasaki 1500 Classic, VN800B Vulcan
Classic. 1995 to 2005 models.**

**Detachable system allows easy removal.
Stylish and Functional.**

Before assembly, read Warnings inside



WARNING

1. During installation, make sure that the fairing and hardware do not interfere with any cables or wiring when the forks are turned all the way in either direction. Also make sure, through the full range of adjustment, that the fairing and hardware do not hit the gas tank.
2. This is a detachable fairing, ALWAYS make sure the locking mechanism is fully engaged after installing the fairing.
3. The improper installation of this kit and related components could result in serious injury or death.



CAUTION

1. Memphis Shades fairings are made from Lucite® acrylic, and will last for years with proper care. Clean your fairing with plenty of soapy water (mild dishwashing liquid is best) and a soft cotton cloth. Use your bare hands to feel and dislodge bugs, or cover with a wet, soapy towel and let it soak. Don't use paper towels and scrape with anything. Small scratches can be removed with NOVUS #2.
2. Never use any glass cleaning products, petroleum based chemicals, or cleaning agents with ammonia, bleach or any other harsh chemicals. This includes (but not limited to) RainX, brake fluid, acetone, paint thinner, benzene and gasoline. "If it hurts your nose, it will hurt the plastic."
3. Glass cleansing agents will cause severe damage to your fairing, and will void your warranty.
4. At certain times of the day the Sunlight can reflect off the curvature of a fairing and cause extreme heat build-up on motorcycle instruments and instrument panel. Take care when parking. Park facing the sun, place an opaque object over the instruments or adjust the fairing to avoid reflections.

1. Kit Contents

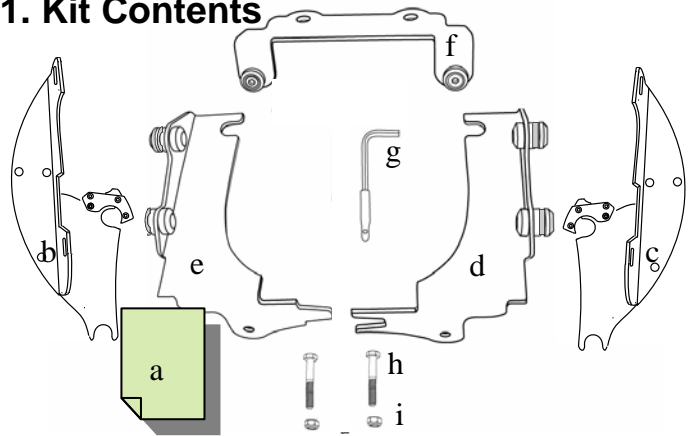

Ref	Code	Description	Qty
(a)	I1923	Mounting instructions	1
(b)	M1269	Clutch side plate assembly	1
(c)	M1268	Throttle side plate assembly	1
(d)	M1357	Clutch side bracket assembly	1
(e)	M1358	Throttle side bracket assembly	1
(f)	S1093	Upper bracket assembly	1
(g)	M310	3/16" short arm allen wrench & cover	1
(h)	M318	6mm x 40mm screw	2
(i)	M319	6mm SS nylon locking nut	2

2. Mounting Instructions

Additional tools required that are not included in this kit. Phillips Head Screwdriver, 7/16" or 11mm, 17mm, 10mm, 8mm Wrench, or 1/4 socket and ratchet.

1. **Cover gas tank and front fender with towels to avoid damage during installation.**
2. Remove the headlight lens using a Phillips screwdriver to remove the two small retaining screws located on either side of the headlight bucket. Unplug the light and set it in a safe place.
3. Using a 8mm wrench and a 10mm wrench, remove the headlight bucket and bracket from the lower triple tree and set them a safe place. (Fig 1).
4. Remove the two 17mm handlebar bolt nuts (*located under the upper triple tree, Fig.2*) and slip the cable holder off the bolts. Install the upper mounting bracket from the kit (*tabs pointing down*), on to the bolts, slip the cable holder back on to the bolts. Thread the nuts on to the bolts and tighten them. Loosen the two anchor bolts on this bracket.

Continued overleaf.....

Memphis Shades warrants all product components, metal and plastic, against defects in materials and workmanship for 24 months.

For Parts and Warranty Help, Contact:

Memphis Shades, Inc.

P.O. Box 429

Rossville, TN 38066

(901) 853 0293

Visit us on the web at www.memphisshades.com or you can also reach us by email:

customerservice@memphisshades.com

**Metric Batwing Fairing Mounting Kit.
Kawasaki 1500 Classic, VN800B Vulcan
Classic. 1995 to 2005 models.**

2. Mounting Instructions, continued

5. Install the two inter-locking brackets by sliding them into the anchor bolts of the upper bracket and under the headlight bracket. (*make sure the tabs inter-lock under the headlight bracket, Fig.3*) Re-install the headlight bracket using the new 6mm x 40mm bolts provided. Tighten **ALL** mounting bolts.

6. Re-install the headlight bucket on to the bracket and re-install the headlight lens.

7. Install the two mounting plates onto the fairing, using the acorn nuts and washers supplied with the fairing. (Fig 4)

8. Install the fairing by placing the lower slots into the lower mounting bushings. Slip the upper slots into the upper mounting bushings and gently but firmly seat the slots into place. Lock the locking mechanism into place. Fig 5

Note: This is a quick change kit, ALWAYS tighten all mounting bolts after removing or installing the fairing!

Fig. 4

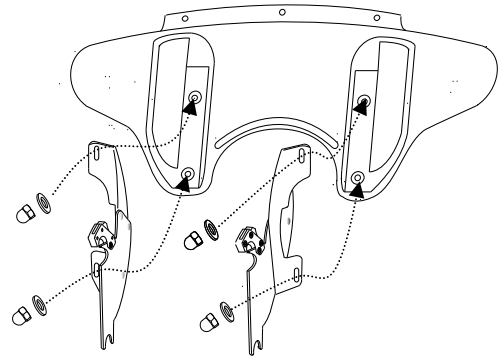
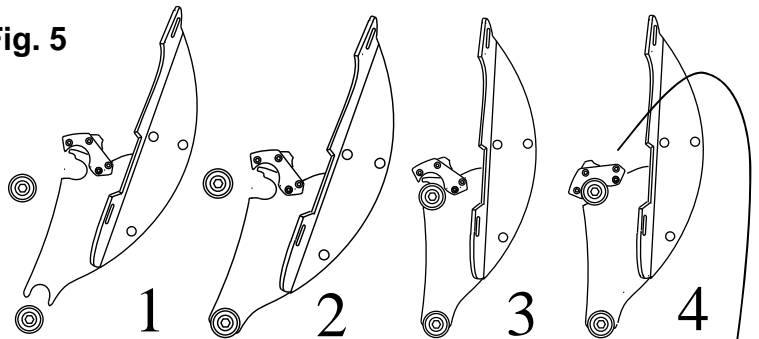
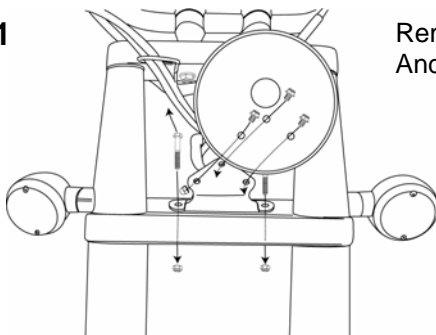

Fig. 5



1. Place lower slot into lower bushing.
2. Rotate top slot into place.
3. Secure locking Mechanism.
4. Loosen Allen Bolt to adjust angle, then re-tighten Allen Bolt.

Fig. 1



Remove Headlight And Bracket.

Fig. 2

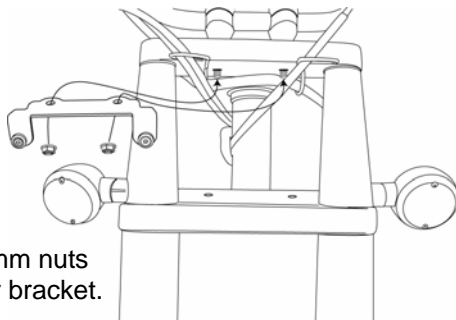

Remove the 17mm nuts and install upper bracket.

Fig. 3

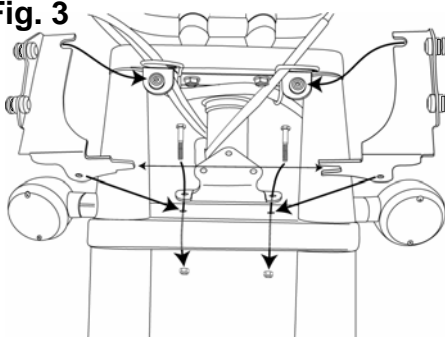

Slide the two brackets into the upper mount and under the headlight bracket

