



Part No. 2321-0222

MEB8982

REVISION 0

**Trigger Lock Mounting Kit  
MS Fats / Slim  
Black**

**Aluminum parts are electrocoated (E-coated) for durability and weather resistance.**

Before assembly, read Warnings inside



**WARNING**

1. During installation, make sure that the windshield and hardware do not interfere with any cables or wiring when the forks are turned all the way in either direction. Also make sure , through the full range of adjustment, that the windshield and hardware do not hit the gas tank.
2. This is a detachable windshield, ALWAYS make sure the locking mechanism is fully engaged after installing the windshield.
3. The improper installation of this kit and related components could result in serious injury or death.



**CAUTION**

1. Memphis Shades windshields are made from Lucite® acrylic, and will last for years with proper care. Clean your windshield with plenty of soapy water (mild dish-washing liquid is best) and a soft cotton cloth. Use your bare hands to feel and dislodge bugs, or cover with a wet, soapy towel and let it soak. Don't use paper towels and scrape with anything. Small scratches can be removed with NOVUS #2.
2. Never use any glass cleaning products, petroleum based chemicals, or cleaning agents with ammonia, bleach or any other harsh chemicals. This includes (but not limited to) RainX, brake fluid, acetone, paint thinner, benzene and gasoline. "If it hurts your nose, it will hurt the plastic."
3. Glass cleansing agents will cause severe damage to your windshield, and will void your warranty. For care and cleaning we recommend using **Memphis Shades All Kleer**, a unique cleaner/polish, bug remover and rain repellent that leaves a super slick surface that makes the next cleaning even easier.
4. At certain times of the day the Sunlight can reflect off the curvature of a windshield and cause extreme heat build-up on motorcycle instruments and instrument panel. Take care when parking. Park facing the sun, place an opaque object over the instruments or adjust the windshield to avoid reflections.

**1. Kit Contents**

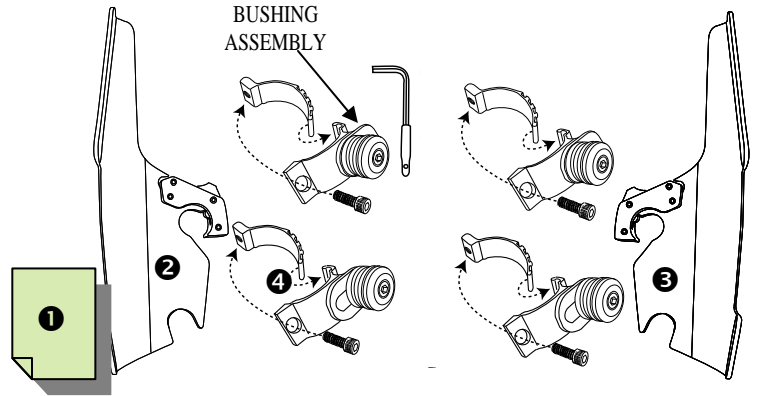

Ref	Code	Description	Qty
①	I8982B	Mounting Instructions	1
②	M1197EB	Clutch side mounting plate assembly	1
③	M1196EB	Throttle side mounting plate assembly	1
④	S1166EC	Small detachable fork clamp assembly	4

**2. Mounting Instructions**

Additional tools required that are not included in this kit. 7/16" or 11mm Wrench.

**1. Cover gas tank and front fender with towels to avoid damage during installation.**

2. Install the two mounting plates onto the windshield, using the bottom and third bolt up. Leave the nylon washers off. The small tab goes to the bottom, big one at the top. *Tabs point in towards the headlight.* (Fig 1)

**WARNING**

If the adjustable clamps are installed backwards, it will result in serious gas tank damage. Always check for proper gas tank clearance before tightening hardware.

3. Loosely install the four Fork Clamps on the forks, approximately 2" apart. (Fig 2). The Top Fork Clamp **must** sit against the Upper Triple Tree (Fig 3)

4. Start with Fork Clamp Bushing adjusted to rear of slot (Fig 4) Then adjust as needed and check for clearance.

5. Slip the windshield mounting plates and windshield onto the fork clamps, (Fig 5) and secure the left and right side locking mechanism

6. Adjust the height, angle and alignment of the windshield and tighten **ALL** bolts.

**Note: This is a detachable windshield, ALWAYS make sure the Locking Mechanism is Fully Engaged after installing the windshield!**

Memphis Shades warrants all product components, metal and plastic, against defects in materials and workmanship for 24 months.

**For Parts and Warranty Help, Contact:**

Memphis Shades, Inc.  
P.O. Box 429  
Rossville, TN 38066  
(901) 853 0293

Visit us on the web at [www.memphisshades.com](http://www.memphisshades.com) or you can also reach us by email:

**Trigger Lock Mounting Kit**  
**MS Fats / Slim**  
**Black**

**2. Mounting Instructions, continued**

**Fig. 1**

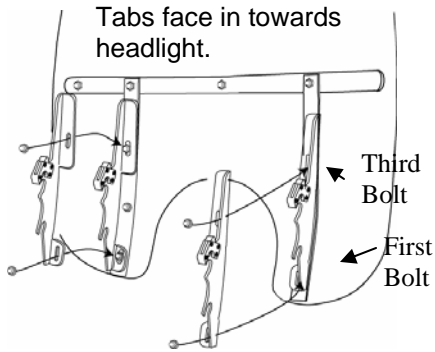

**Fig. 2**

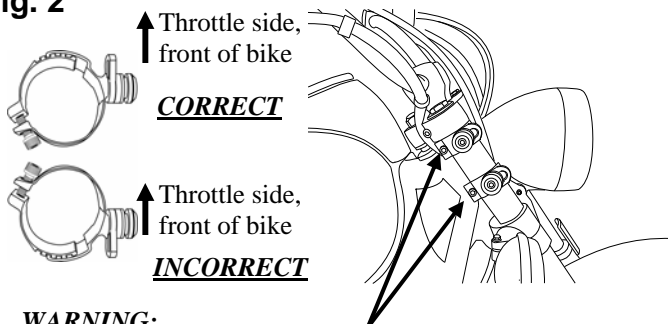

**WARNING:**

"Mounting clamps backwards will cause damage to your tank."

Side view. When installed correctly, Allen bolts are tightened from the back side of the fork, not the front.

**Fig. 3**

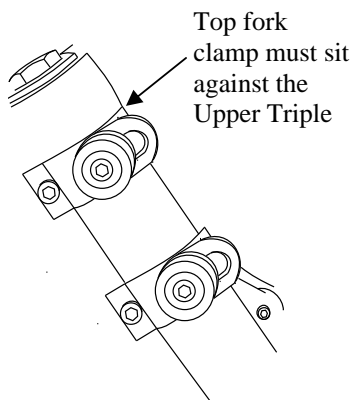

**Fig. 4**

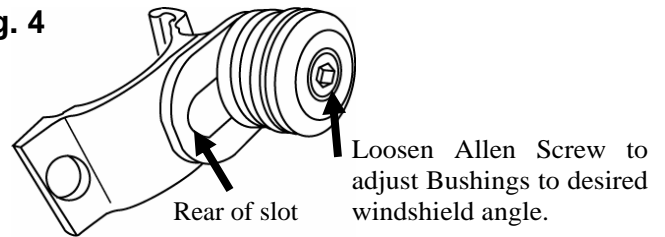

**Fig. 5**

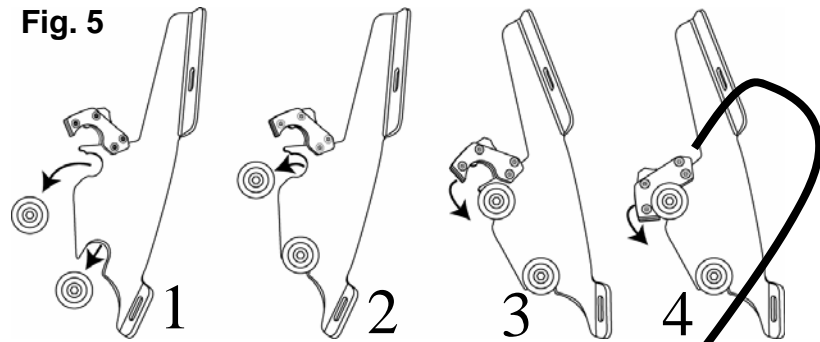

1. Place lower slot into lower bushing.
2. Rotate top slot into place.
3. Secure locking Mechanism.
4. Loosen Allen Bolt to adjust angle, then re-tighten Allen Bolt.

