



Part No. 2320-0136



MEK1996

REVISION 08042014

Trigger Lock Mounting Kit
MS Café Fairing
HD XL1200X Sportster Forty Eight

Aluminum parts are electrocoated (E-coated) for durability and weather resistance.

Before assembly, read Warnings inside



WARNING

1. During installation, make sure that the fairing and hardware do not interfere with any cables or wiring when the forks are turned all the way in either direction. Also make sure , through the full range of adjustment, that the fairing and hardware do not hit the gas tank.
2. This is a detachable fairing, ALWAYS make sure the locking mechanism is fully engaged after installing the fairing.
3. The improper installation of this kit and related components could result in serious injury or death.



CAUTION

1. Memphis Shades fairings are made from Lucite® acrylic, and will last for years with proper care. Clean your fairing with plenty of soapy water (mild dishwashing liquid is best) and a soft cotton cloth. Use your bare hands to feel and dislodge bugs, or cover with a wet, soapy towel and let it soak. Don't use paper towels and scrape with anything. Small scratches can be removed with NOVUS #2.
2. Never use any glass cleaning products, petroleum based chemicals, or cleaning agents with ammonia, bleach or any other harsh chemicals. This includes (but not limited to) RainX, brake fluid, acetone, paint thinner, benzene and gasoline. "If it hurts your nose, it will hurt the plastic."
3. Glass cleansing agents will cause severe damage to your fairing, and will void your warranty. For care and cleaning we recommend using **Memphis Shades All Kleer**, a unique cleaner/polish, bug remover and rain repellent that leaves a super slick surface that makes the next cleaning even easier.
4. At certain times of the day the Sunlight can reflect off the curvature of a fairing and cause extreme heat build-up on motorcycle instruments and instrument panel. Take care when parking. Park facing the sun, place an opaque object over the instruments or adjust the fairing to avoid reflections.

1. Kit Contents

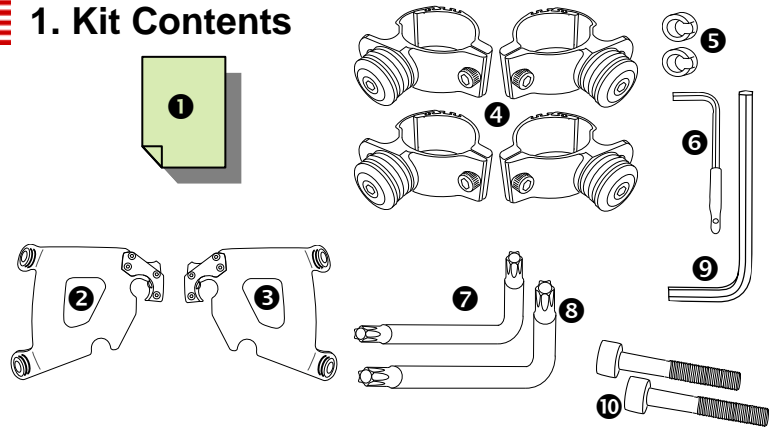

Ref	Code	Description	Qty
①	I1996	Mounting Instructions	1
②	M1596EC	Mounting plate, clutch side	1
③	M1597EC	Mounting plate, throttle side	1
④	S1215EC	Small detachable clamp assembly	4
⑤	R561EB	Spacer	2
⑥	M310	Short arm allen wrench, 3/16	1
⑦	R360	Short arm torx key, T40	1
⑧	R361	Short arm torx key, T45	1
⑨	R362	Short arm allen wrench, 5/16	1
⑩	R363	Socket head cap screw, 3/8-16 x 2	2

2. Mounting Instructions

Additional tools required that are not included in this kit. 7/16(11mm), 1/2(13mm), 9/16(14mm) wrench.

1. **Cover gas tank and front fender with towels to avoid damage during installation.**
2. Remove the bolt and washer securing the Turn Signal Lamp from the Upper Triple Tree (Fig 1a). Let the Turn Signal Lamp hang by its cable. Refit the bolt into the Upper Triple Tree and tighten. Retain the washer. **WARNING: Remove, Replace and Retighten one bolt at a time to prevent fork tube from slipping in triple clamp!**
3. Remove the bolt from the Lower Triple Tree (Fig 1b). Using the bolt provided ⑩, the washer from step 2, and spacer ⑤ provided, fit the Turn Signal Lamp into the Lower Triple Tree.
4. Repeat for the other Turn Signal Lamp.

Memphis Shades warrants all product components, metal and plastic, against defects in materials and workmanship for 24 months.

For Parts and Warranty Help, Contact:

Memphis Shades, Inc.

P.O. Box 429

Rossville, TN 38066

(901) 853 0293

Visit us on the web at www.memphisshades.com or you can also reach us by email:

customerservice@memphisshades.com

2. Mounting Instructions, continued

5. On the Throttle side, remove the bolt holding the Mirror in place (Fig 2a). Remove the mirror and re-route the throttle cables to the inside. Reinstall the mirror (Fig 2b)

6. Slide rubber boot off clutch cable adjuster - Located about halfway along clutch cable by front frame downtube. (Fig. 3)

7. Holding the cable adjuster with a 1/2 in wrench, loosen jam nut with a 9/16 in. wrench. Back jam nut away from cable adjuster. Move adjuster towards jam nut to allow free play at hand lever.

8. Remove retaining ring from pivot pin groove at bottom of clutch lever, and remove pivot pin. Remove clutch hand lever from bracket.

9. Re-route the clutch cable to inside of handlebars (Fig. 4)

10. Reinstall clutch lever, pivot pin and retaining ring, then turn cable adjuster away from jam nut until slack is eliminated at hand lever then tighten jam nut.

11. Install the Mounting plate assemblies ② and ③ onto the fairing, using the bolts that are pre-assembled on the Mounting plate assemblies.

The Santoprene grommets should be inserted through the holes in the fairing so that the flat round part of the grommet lies flat on each side of the plastic. Tabs point in towards the headlight. (Fig. 5)

12. Loosely install the four Fork Clamps ④ on the forks, approximately 2" apart. (Fig 6)

13. Slip the fairing mounting plates and fairing onto the fork clamps, (Fig 7) while guiding the bezel over the headlight (Fig. 5) and secure the left and right side locking mechanism

14. Adjust the height, angle and alignment of the fairing and tighten **ALL** bolts.

Note: This is a detachable fairing, ALWAYS make sure the Locking Mechanism is Fully Engaged after installing the windshield! (Fig 8)

Fig. 1a

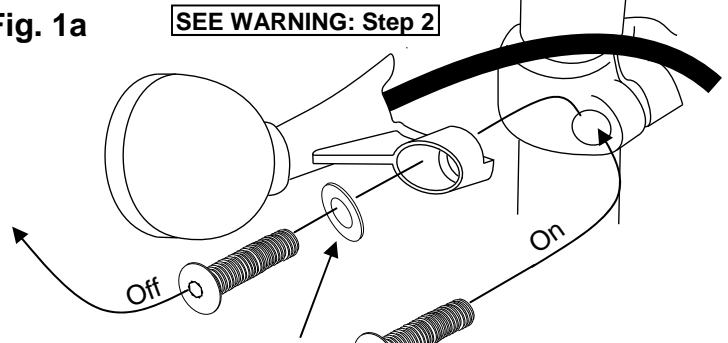

Fig. 1b

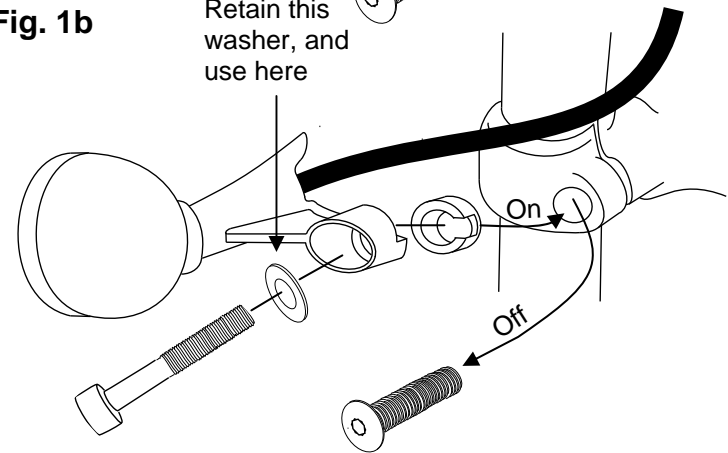

Fig. 2a

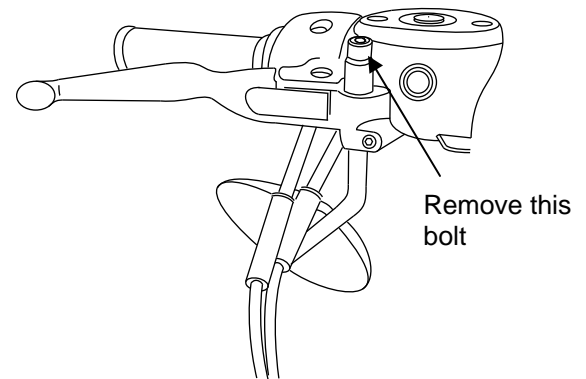

Fig. 2b

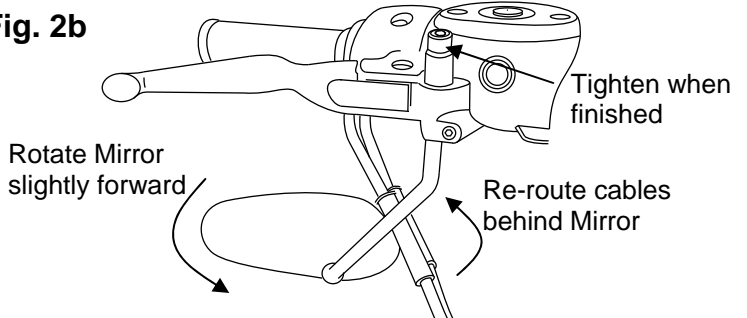

Fig. 3

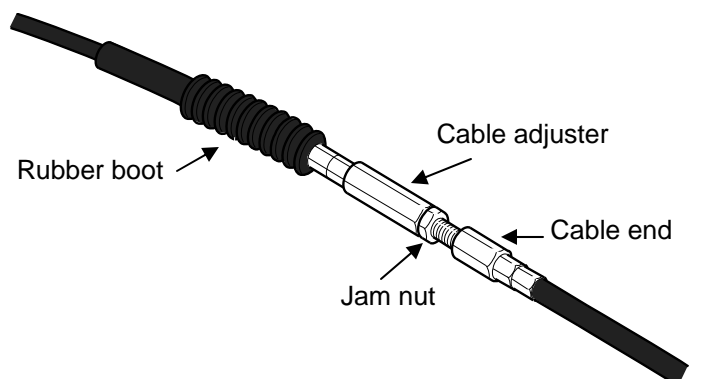

Fig. 4

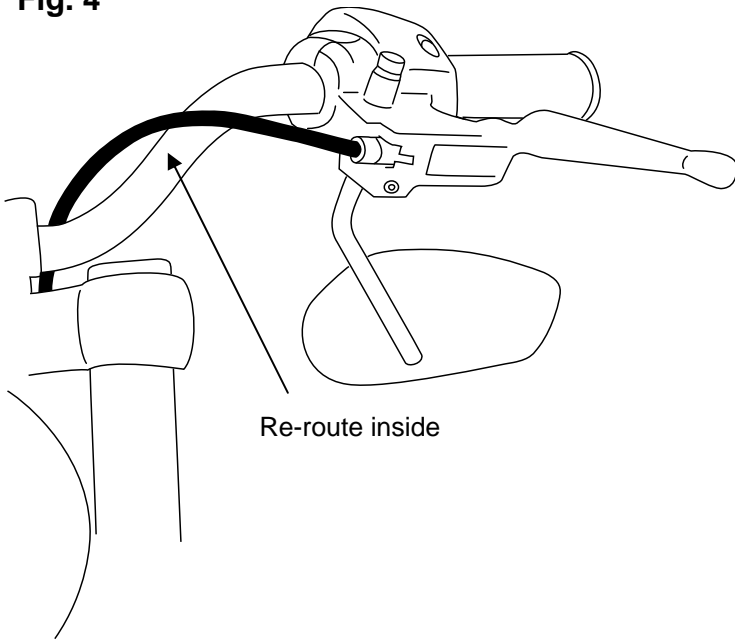

Fig. 5

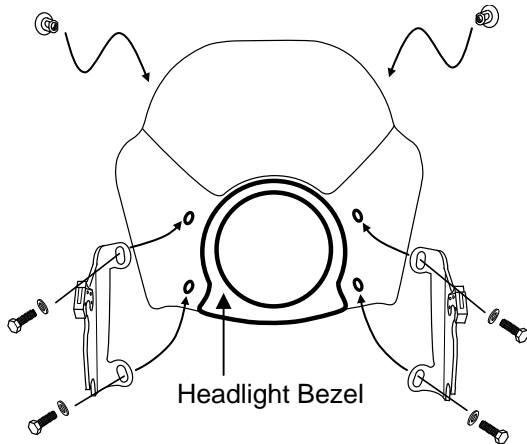

Fig. 6

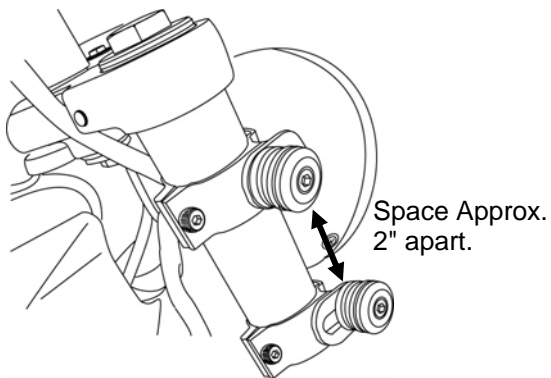
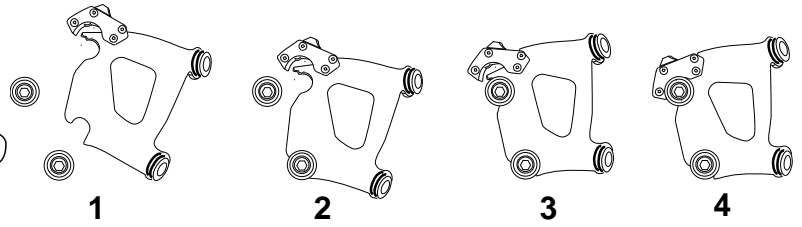

Fig. 7



1. Place lower slot into lower bushing.
2. Rotate top slot into place.
3. Secure locking Mechanism.
4. Loosen Allen Bolt to adjust angle, then re-tighten Allen Bolt.

Fig. 8

Latch assembly

