



## Custom Dynamics® LED Plugz™ Installation Instructions

We thank you for purchasing the Custom Dynamics® LED Plugz™! Our products utilize the latest technology and high quality components to ensure you the brightest, most reliable LED's on the market. We offer one of the best warranty programs in the industry and we back our products with excellent customer support, if you have questions before or during installation of this product please call Custom Dynamics® at 1(800) 382-1388.

**Part Number(s):** GEN-PLUGZ-R GEN-PLUGZ-S  
GEN-PLUGZ-R-B GEN-PLUGZ-S-B

### Package Includes:

- LED Plugz™ (pair)
- Posi-Taps® (4)

### Optional Items Purchased Separately:

- Dual Converter TFC1 (for dual function)
- Smart Triple Play® (Run, Brake, Turn Controller)
- Eclipse2® (EPZ2) Module (for Brake/turn)
- MPR-BCM (Plug and play adapter 2014-2018 HD Touring)

**Fits:** All Street Glides®, Road Glide® Customs and Road King® Specials (Does not fit CVO™ models)

1. Remove the saddlebags to allow access to the inside filler strip.
2. Remove the stock rubber plugs and/or grommets from the antenna port holes in the filler strip. (See Figures 1&2)
3. Take the LED Plugz™ wires and feed through the holes first, followed by the LEDs, push the units firmly into place.

### Wiring Options

Depending on your bike's equipment, there are different options for the function of the LED Plugz™. The wiring diagrams on page 2 shows the function combinations. If you have a Run/brake/turn module installed, or have a bike without a center tail light, see the wiring diagrams on page 3. Please note that for some of the different functions, additional items may be required. For 2014-2018 Street Glides, see page 4.

Using the supplied Posi-Tap™ Connectors, follow the wiring instructions below:

4. Connect Black wire to good ground.
5. Connect Red wire to 12VDC power source such as brake or turn signal wire, depending on use.

**Note:** If you already have Plasma Rods™ installed working as run/brake/turn, you can simply tap into their wires at the connection, no converter will be needed)

4. If Dual Converter is to be used, connect red wire on the Plugz™ to the single red wire side of the dual converter. Connect red wire on opposite end to brake or turn signal power source and the orange to 12VDC running light source.
5. If EPZ2 converter is to be used, connect red and black wires to red and black wires of EPZ2 (2 wire side). Connect red wire on opposite end to brake power source, orange wire to turn signal source, and black wire to the ground.
6. Check operation of LED Plugz™ in all modes.

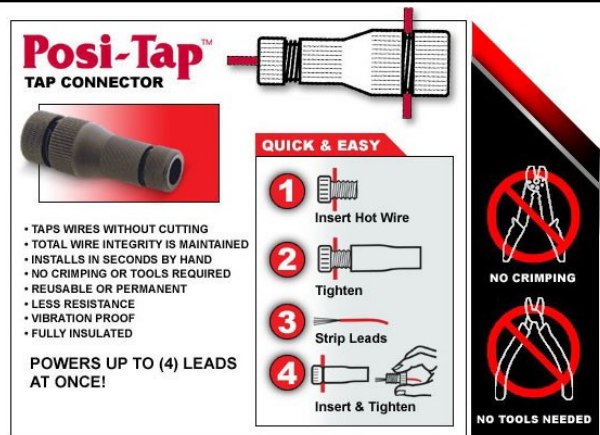

**Note:** If you experience a fast flash on your turn signals as if a bulb is out, a load equalizer or our Slim Line Signal Stabilizer™ is recommended. Contact us for details.

**Note:** This product is designed and intended for use as auxiliary lighting on motorcycles only. This product is NOT intended to replace any original equipment lighting installed on the motorcycle and should not be used for that purpose. This product must be wired such that it does not interfere with any original equipment lighting.

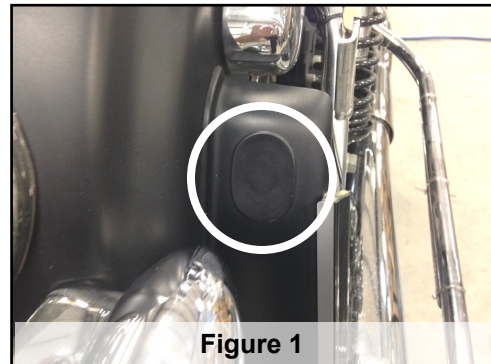

Figure 1

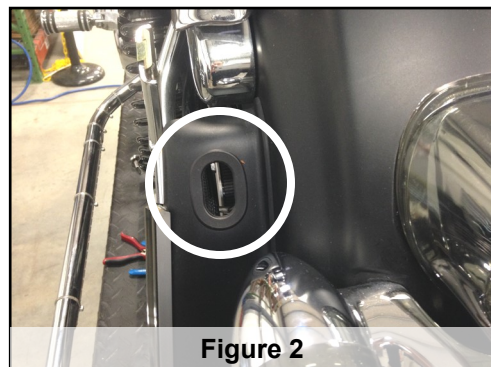
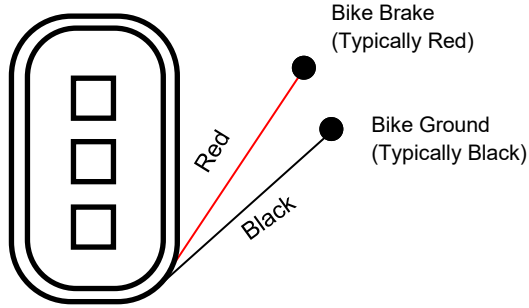

Figure 2

Questions? Call us at: 1 (800) 382-1388 M-TH 8:30AM-5:30PM / FR 9:30AM-5:30PM EST

# Installation Instructions - Page 2

## LED Plugz™ as Brake Only



## LED Plugz™ as Turn Only

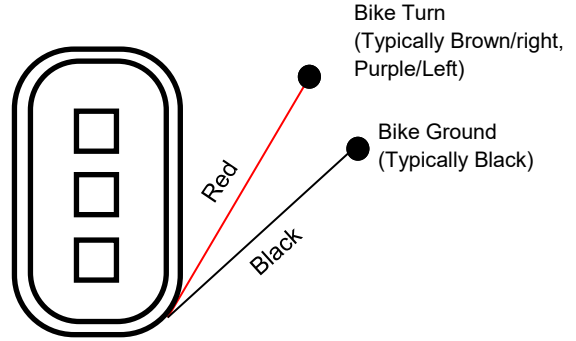

## LED Plugz™ as Run/Brake (Dual Converter Required)

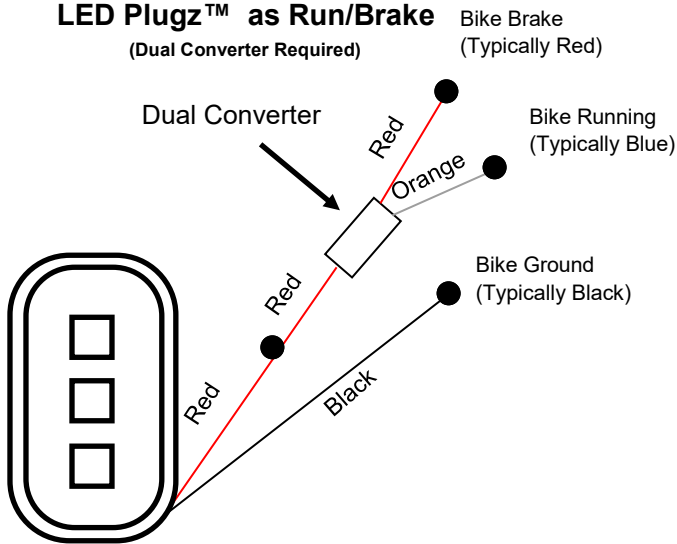

## LED Plugz™ as Run/Turn (Dual Converter Required)

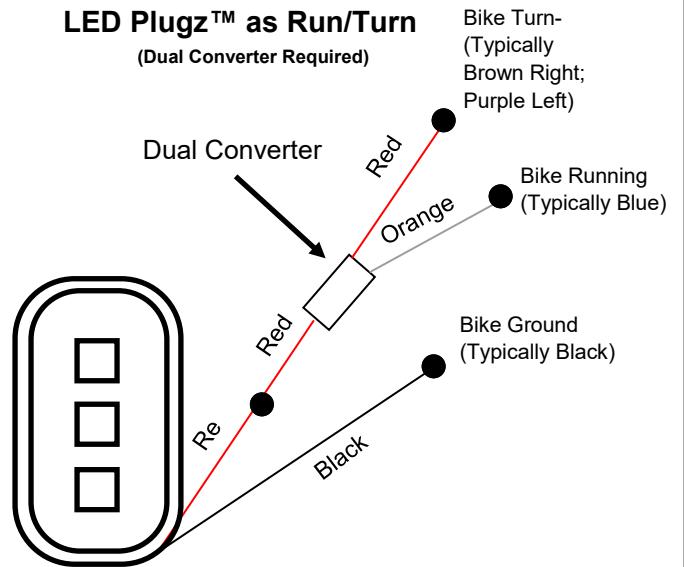

## LED Plugz™ as Brake/Turn (Eclipse2® Module Required)

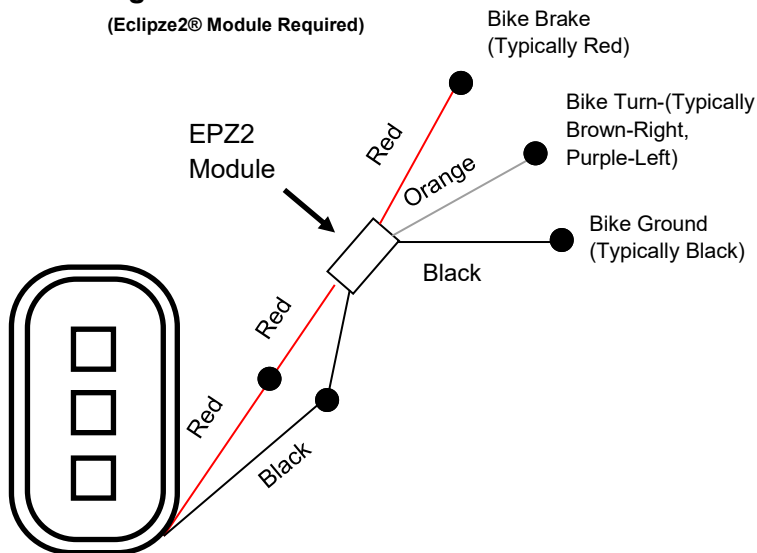

● = Connection Points



**Note:** Always confirm your bike's wiring with a test light to make sure you are tapping into the correct wires.

# Installation Instructions - Page 3

## LED Plugz™ as Run/Brake/Turn on Bike with After Market Run-Brake-Turn Controller

(Controller Sold Separately)

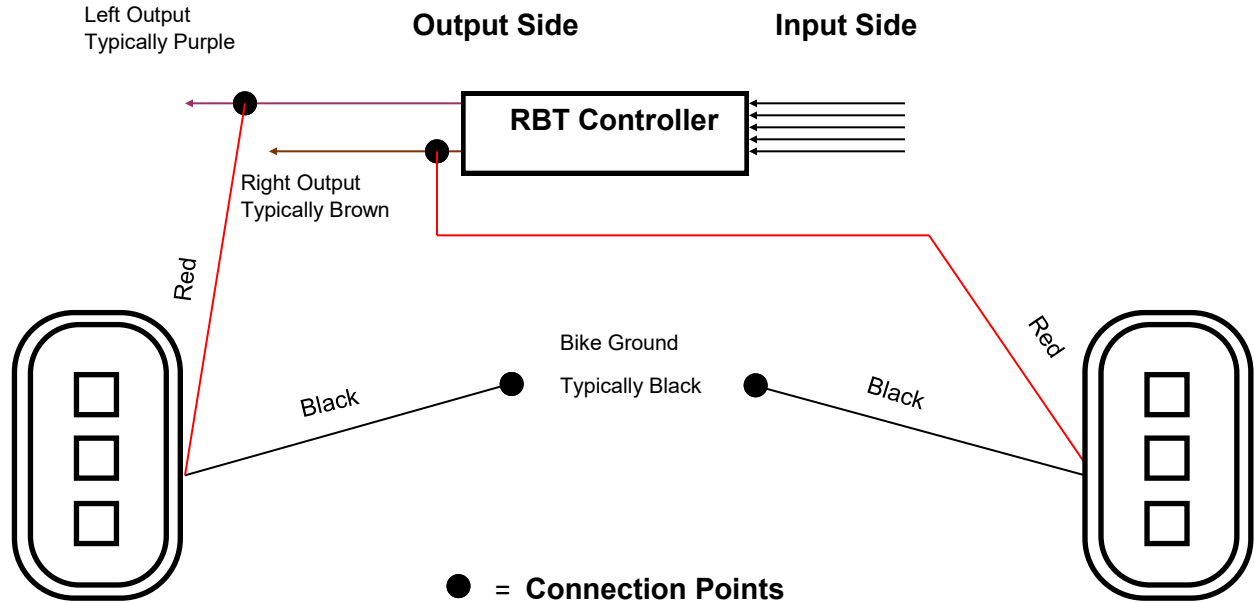

## LED Plugz™ as Run/Brake/Turn on 2010-2013 Street Glide & Road Glide Custom

Output Side, Right Side of fender, remove back cover of Tri-bar, for Access,  
Use Test Light to Determine what Purple is left and what is Right

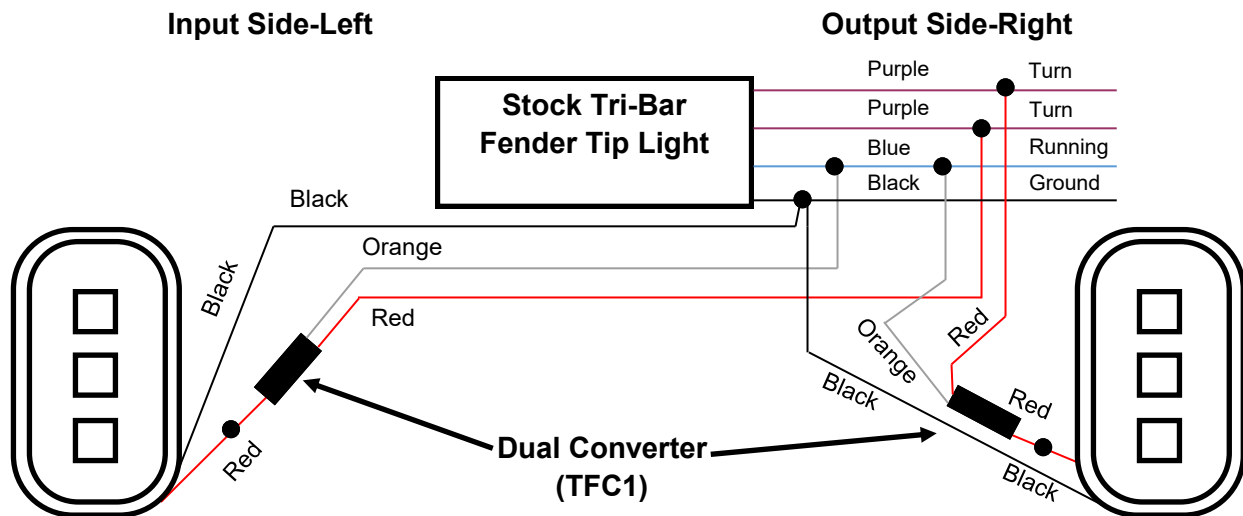

Questions? Call us at: 1 (800) 382-1388 M-TH 8:30AM-5:30PM / FR 9:30AM-5:30PM EST

# Installation Instructions - Page 4

## LED Plugz™ as Run/Brake/Turn on 2014-2018 HD Touring

### MPR-BCM Diagram (Sold Separately) Wire Harness Color/Functions

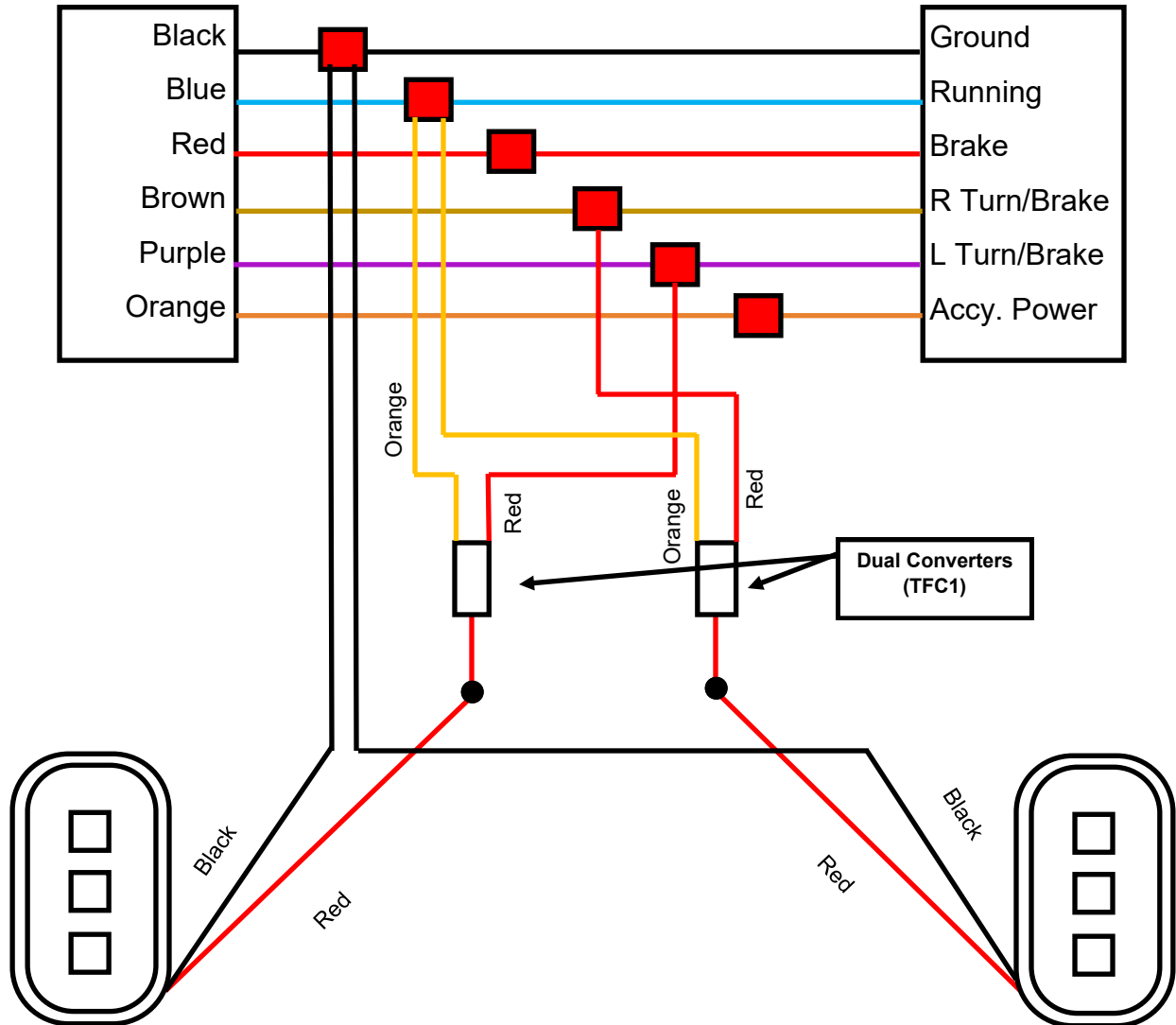

This diagram demonstrates run/brake/turn with the MPR-BCM adapter and (2) TFC1 dual converters (each sold separately). Other Functions available:

Brake/Turn - Using the MPR-BCM and omitting the dual converters.

Run/Brake - Using the BCM and dual converters connecting the orange wire from the dual converter to the Blue wire, and the red wire from the dual converter to the Red wire in the MPR.

2014-2018 HD motorcycles do not need a load equalizer when removing stock turn signals.

# Installation Instructions - Page 5

## LED Plugz™ as Run/Brake/Turn on 2014-2018 HD Touring

Stock Wire Harness Color/Functions  
(note: when NOT using MPR-BCM harness adapter)

