

Instruction 106-6067
04-05-16

Version 3

Copyright © 2008, 2014. 2016
by S&S® Cycle, Inc.

All rights reserved.
Printed in the U.S.A.

S&S® Cycle, Inc.

14025 Cty Hwy G, PO Box 215
Viola, Wisconsin 54664
Phone: 608-627-1497 • Fax: 608-627-1488
Technical Service Phone: 608-627-TECH (8324)
Technical Service Email: sstech@sscycle.com
Website: www.sscycle.com



Installation Instructions: S&S® Standard & Easy Start Gear Drive Camshafts for 2007–up Harley-Davidson® Big Twin and 2006 Dyna® Models

DISCLAIMER:

Many S&S parts are designed for high performance, closed course, racing applications and are intended for the very experienced rider only. The installation of S&S parts may void or adversely affect your factory warranty. In addition such installation and use may violate certain federal, state, and local laws, rules and ordinances as well as other laws when used on motor vehicles used on public highways. Always check federal, state, and local laws before modifying your motorcycle. It is the sole and exclusive responsibility of the user to determine the suitability of the product for his or her use, and the user shall assume all legal, personal injury risk and liability and all other obligations, duties, and risks associated therewith.

**NOT LEGAL FOR SALE OR USE IN CALIFORNIA ON ANY
POLLUTION CONTROLLED MOTOR VEHICLES**

SAFE INSTALLATION AND OPERATION RULES:

Before installing your new S&S part it is your responsibility to read and follow the installation and maintenance procedures in these instructions and follow the basic rules below for your personal safety.

- Gasoline is extremely flammable and explosive under certain conditions and toxic when breathed. Do not smoke. Perform installation in a well ventilated area away from open flames or sparks.
- If motorcycle has been running, wait until engine and exhaust pipes have cooled down to avoid getting burned before performing any installation steps.
- Before performing any installation steps disconnect battery to eliminate potential sparks and inadvertent engagement of starter while working on electrical components.
- Read instructions thoroughly and carefully so all procedures are completely understood before performing any installation steps. Contact S&S with any questions you may have if any steps are unclear or any abnormalities occur during installation or operation of motorcycle with a S&S part on it.
- Consult an appropriate service manual for your motorcycle for correct disassembly and reassembly procedures for any parts that need to be removed to facilitate installation.
- Use good judgment when performing installation and operating motorcycle. Good judgment begins with a clear head. Don't let alcohol, drugs or fatigue impair your judgment. Start installation when you are fresh.
- Be sure all federal, state and local laws are obeyed with the installation.
- For optimum performance and safety and to minimize potential damage to carb or other components, use all mounting hardware that is provided and follow all installation instructions.
- Motorcycle exhaust fumes are toxic and poisonous and must not be breathed. Run motorcycle in a well ventilated area where fumes can dissipate.

IMPORTANT NOTICE:

Statements in this instruction sheet preceded by the following words are of special significance.



WARNING

Means there is the possibility of injury to yourself or others.



CAUTION

Means there is the possibility of damage to the part or motorcycle.

NOTE

Other information of particular importance has been placed in italic type.

S&S recommends you take special notice of these items.

WARRANTY:

All S&S parts are guaranteed to the original purchaser to be free of manufacturing defects in materials and workmanship for a period of twelve (12) months from the date of purchase. Merchandise that fails to conform to these conditions will be repaired or replaced at S&S's option if the parts are returned to us by the purchaser within the 12 month warranty period or within 10 days thereafter.

In the event warranty service is required, the original purchaser must call or write S&S immediately with the problem. Some problems can be rectified by a telephone call and need no further course of action.

A part that is suspect of being defective must not be replaced by a Dealer without prior authorization from S&S. If it is deemed necessary for S&S to make an evaluation to determine whether the part was defective, a return authorization number must be obtained from S&S. The parts must be packaged properly so as to not cause further damage and be returned prepaid to S&S with a copy of the original invoice of purchase and a detailed letter outlining the nature of the problem, how the part was used and the circumstances at the time of failure. If after an evaluation has been made by S&S and the part was found to be defective, repair, replacement or refund will be granted.

ADDITIONAL WARRANTY PROVISIONS:

- (1) S&S shall have no obligation in the event an S&S part is modified by any other person or organization.
- (2) S&S shall have no obligation if an S&S part becomes defective in whole or in part as a result of improper installation, improper maintenance, improper use, abnormal operation, or any other misuse or mistreatment of the S&S part.
- (3) S&S shall not be liable for any consequential or incidental damages resulting from the failure of an S&S part, the breach of any warranties, the failure to deliver, delay in delivery, delivery in non-conforming condition, or for any other breach of contract or duty between S&S and a customer.

Cam Name	Lobe	Timing		Duration	Lift	Centerline	TDC Valve Lift	05-UP Models works with stock valve springs	works with stock pushrods
		Open	Close						
510G	Int	20°	38°	238°	0.510"	99°	0.187"	X	X
	Exh	52°	20°	252°		106°	0.179"		
551 (E)	Int	17°	19°	216°	0.550"	91°	0.178"	X	X
	Exh	41°	17°	238°		102°	0.170"		
557	Int	6°	27°	212°	0.557"	100°	0.113"	X	X
	Exh	39°	12°	231°		103°	0.146"		
570 (E)	Int	20°	40°	240°	0.570"	100°	0.187"	X	X
	Exh	55°	20°	255°		107.5°	0.179"		
583 (E)	Int	5°	18°	203°	0.583"	96.5°	0.113"	X	X
	Exh	58°	24°	262°		107°	0.206"		
585 (E)	Int	20°	45°	245°	0.585"	102.5°	0.186"	X	X
	Exh	60°	20°	260°		110°	0.179"		
625 (E)	Int	20°	55°	255°	0.625"	107.5°	0.189"		
	Exh	60°	20°	260°		110°	0.184"		
635	Int	19.5°	43.5°	243°	0.635"	102°	0.186"		
	Exh	58.5°	37.5°	276°		100.5°	0.284"		
640 (E)	Int	25°	60°	265°	0.640"	107.5°	0.228"		
	Exh	65°	25°	270°		110°	0.214"		
675 (E)	Int	25°	60°	269°	0.675"	109.5°	0.235"		
	Exh	74°	25°	275°		112.5°	0.205"		
HP103	Int	20°	49°	249°	0.575"	102.7°	0.199"	X	X
	Exh	45°	26°	251°		101.5°	0.206"		
MR103	Int	13°	33°	226°	0.585"	100°	0.097"	X	X
	Exh	50°	22°	252°		104°	0.191"		

Chart 1

NOTES:

2005-up stock valve springs will handle camshafts with lift up to 0.585". If a camshaft with higher lift is installed, high performance valve springs capable of handling a greater lift must be used.

A cam with over 0.585" of lift will cause interference between the valve spring top collar and the valve seal with stock cylinder heads.

S&S camshaft installation Kit 106-6068 is strongly recommended when installing S&S cam gear drive. This kit includes hardware, gaskets and bearings required for cam installation, this kit includes oil pump o-rings.

OVERVIEW OF EASY START CAMSHAFTS

S&S® has developed Easy Start cams to assist starting with a built in centrifugal compression release. The operation is simple: at cranking speeds, a spring loaded decompression lever opens the exhaust valve slightly, reducing cranking compression. Once the engine fires and exceeds 750 RPM, centrifugal force retracts the lever, allowing the engine to run normally with full compression.

The various grinds of S&S Easy Start cams are designed to be used with a specific range of displacement and compression ratio. Some EFI engines may not start if the compression is too low. See special notes on Page 6.



Cams with more than .585" lift require that the stock valve springs be replaced with high lift spring kits. Some high lift spring kits require clearance checks and many require cylinder head modifications to prevent contact between top color and valve seal, and to achieve correct installed height. See the instructions with your spring kit for exact specifications.

Piston to valve clearance will need to be confirmed when using a cam with over 0.585" of lift. Clearance should be at least 0.060" intake and .080" exhaust.

Valve to valve clearance will need to be confirmed when using a cam over 0.585" lift. Clearance should be a minimum of 0.060".

COMPATIBILITY NOTES:

S&S Cam Gear Drive is not compatible with camshafts designed for the stock style chain cam drive. S&S Cam Gear Drive must be used with S&S gear drive style camshafts.

2006-Up gear driven camshafts kits 510G, 551G, 570G, 583G and 585G are compatible with stock 2006-Up valve springs. Due to the change in lift from the cams, 570G and 585G require adjustable pushrods. S&S adjustable pushrod kit 93-5095 is recommended for engines with stock length cylinders. Longer pushrods are available for engines with longer than stock cylinders. See the S&S Catalog for pushrods.

Cam	Intended Displacement	Intended Compression Ratio
551	88-106	9.0-10.0
557	96-103	9.6-10.0
570	88-106	9.0-10.0
583	88-106	9.0-10.0
585	88-106	9.2-10.5
625	95+	10.0-10.75
635	106-124	10.2-10.8
640	95+	10.5-11.5
675	120+	11+
HP103	103	9.6-10.0
MR103	103	9.6-10.0

Disassembly

1. Remove pushrod cover clips with a small screwdriver and compress pushrod covers to expose pushrods. Lift rear tire of motorcycle with a suitable jack and remove spark plugs.
2. Rotate the engine until one of the cylinders is on "top dead center compression stroke" (TDCC). TDCC can be found by rolling the rear tire forward while watching or feeling the pushrods move through their travel. When BOTH pushrods are at the lowest point of their travel and the piston for that cylinder is at TDC, the engine is at TDCC. Rotate the pushrods to ensure there is no load on them. If the pushrods will not rotate freely by hand, either the engine is not on TDCC, or the lifters need to bleed down. It may be necessary to let the lifters bleed down for a few minutes before the pushrods will rotate freely.
3. If S&S adjustable pushrods will be used for re-assembly, the stock pushrods may be cut to remove them at this time. When cutting pushrods, S&S recommends a bolt cutter be used as it is the cleanest method. Before cutting the pushrods make sure that they are not under spring pressure from the valve springs. They must rotate freely by hand.



Cutting pushrods with a saw or cutoff wheel may result in debris entering engine, causing extensive engine damage not covered under warranty.



Cutting pushrods when they are under spring pressure can result in pushrod parts being ejected with considerable force, and can cause bodily injury.

4. If stock one piece pushrods are to be re-used, remove the gas tank and rocker box covers. Remove the rocker arm support by first removing the two smaller bolts which hold the breather cover in place. Next break loose the four bolts holding the rocker arm support plate in place with an alternating pattern. Remove the four rocker arm support plate bolts, and then the rocker arm support assembly. The pushrods may now be removed by sliding them up into the head slightly and then pulling the bottom of the pushrod towards you. Mark the original pushrod location as it is removed to ensure it is replaced in its original position. The intake pushrod is shorter than the exhaust pushrod. Interchanging the intake and exhaust pushrods upon reassembly, will cause the intake valve to stay open on the compression stroke and the engine will not run.



Picture 1

5. Rotate the engine so the other cylinder is on TDC compression and repeat the above procedure.
6. Remove cam cover and gasket. Secure lifters with a magnetic lifter tool or a tool made from a large binder clip. **See Picture 1.**
7. Rotate rear wheel to align timing marks on the primary cam chain sprockets.
8. Remove the primary chain tensioner by removing the two retaining bolts and install sprocket locking tool.
9. Remove the crank sprocket bolt and flat washer.
10. Remove rear cam sprocket bolt and flat washer.
11. Remove sprocket locking tool.
12. Gently pry off crank sprocket and rear cam sprocket.

Cam Support Plate and Cam Removal

1. Gradually loosen and remove the four oil pump bolts/washers labeled as squares in **Picture 2**, according to the sequence shown.
2. Gradually loosen and remove the six support plate bolts/washers labeled as circles in **Picture 2**, according to the sequence shown.

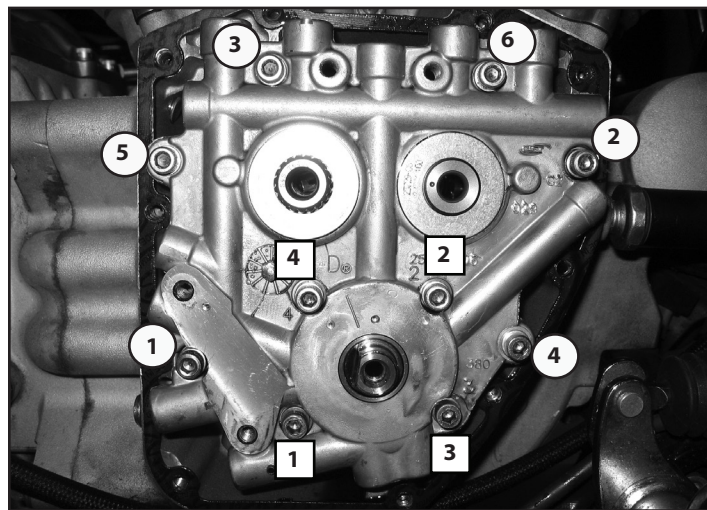

Picture 2

3. Remove spacer from rear cam, this spacer is thicker than the front spacer.
4. Remove cam plate and cams from engine.
5. Remove retaining ring and spacer from front cam. This spacer is 0.100" thick.
6. Remove the secondary cam chain tensioner.
7. Remove the cams and cam chain.
8. Check pinion shaft runout. Place an indicator on the end of pinion shaft at cam support plate bushing surface and rotate engine; reading must be .003" or less total indicated runout (TIR). If reading is greater than .003" TIR the crankshaft must be repaired or replaced to correct excess runout before installing gear drive cams.



If pinion shaft has more than .003" total indicated runout (TIR), the crankshaft must be repaired or replaced to correct excess runout before installing gear drive cams. Failure to correct excess runout may lead to engine damage not covered under S&S warranty.

Installing the Cam Gear Drive

1. Install new needle bearings provided with the S&S® Camshaft installation kit 106-6068 or with bearings from another source. Cam bearings must be Torrington B-168 full complement bearing or equivalent.



Using existing needle bearings may cause engine or cam damage due to increased tolerances from wear and higher loading of cams. Always replace cam bearings with the ones provided in this kit or another source.

2. Install the new hydraulic block off plates where the front and rear chain tensioners were located, tighten fasteners to 100-120 in lbs. See **Picture 3 & 4** below.

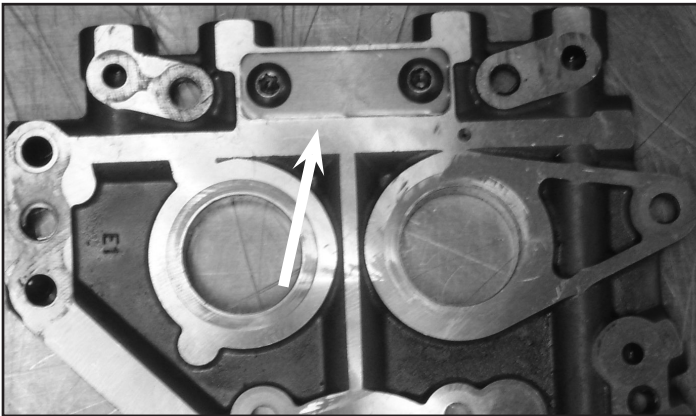

Picture 3

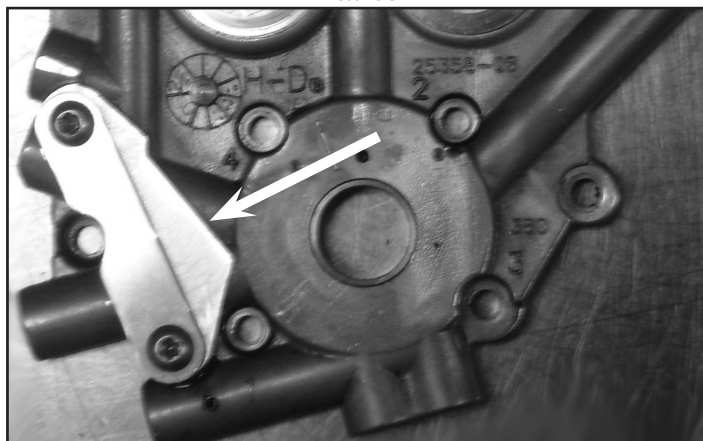

Picture 4

3. When installing 551G, 570G, 583G, 585G, 625G, or 640G camshafts clearance between the pinion bearing boss and the rear cam lobe must be checked. See **Pictures 7 & 8**. Remove just enough material to provide .030" of clearance between the top of the cam lobe and the pinion bearing boss when the camshafts are rotated in the inner needle bearing. Also check clearances between the cam lobe and the tappet guide bosses. To avoid contamination of the engine with chips, we recommend that all holes in the gear case be taped off with duct tape and that the gear case be thoroughly cleaned with parts cleaner or solvent after clearancing is performed.
4. Apply assembly lube to the bearing bore of the support plate and the outer races of the cams and the decompression levers of easy start cams. Slide the S&S® front cam into place.
5. Install the .110" washer on the other side of the support plate over the front cam.

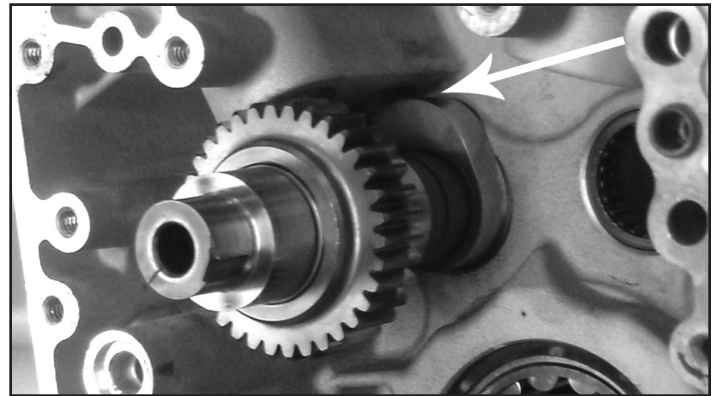

Picture 5

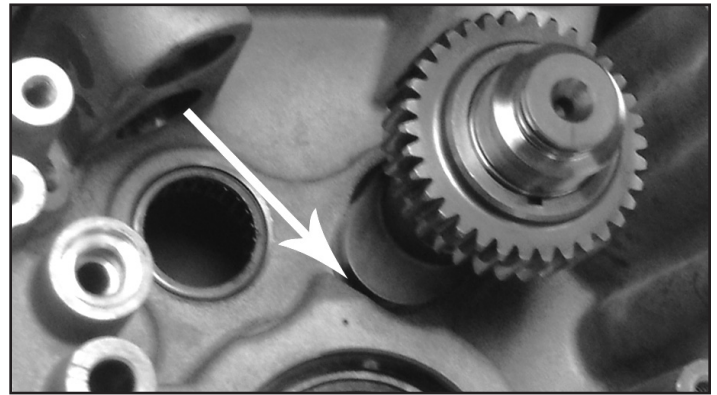

Picture 6

6. Install a new loaded retaining ring onto the end of the front cam to secure it in place.
7. Slide the rear cam into place aligning the timing marks on the back of the cam gears. See **Figures 1 and 2**.

*NOTE: Current production S&S Gear drive camshafts have timing marks shown in **Figure 1**. Older S&S gear drive camshafts, have the timing marks shown in **Figure 2**. Cams with early and late gear styles must not be used together.*

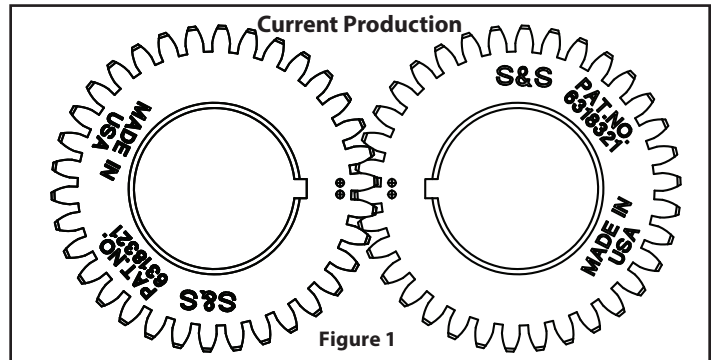

Figure 1

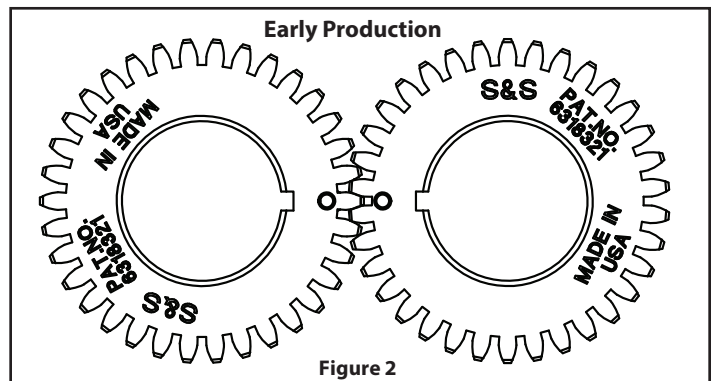

Figure 2

8. Install the new oil pump scavenge o-ring supplied in the installation kit, and coat with assembly lube.

NOTE: Even if the original stock o-ring appears to be in good condition, it may have become brittle or stiff from exposure to heat and motor oil, resulting in a poor seal and inadequate crankcase oil scavenging.

9. Apply a thin layer of assembly lube to cam journals, lobe surfaces, and inner bearing surfaces. Thoroughly lubricate decompression lever of Easy Start Cams. Align camshafts with needle bearings and carefully slide support plate over crankcase dowels.

NOTE: The support plate assembly should slide into place without resistance. If resistance is encountered, determine the cause and correct the problem before proceeding. Do not force the support plate into position. The camshafts must be installed into the cam support plate before installation. Failure to do so could result in damage to the cam support plate and bearing surface.

10. Recheck the cam timing by visually inspecting the timing marks on the front of the camshafts. **See Picture 7.**

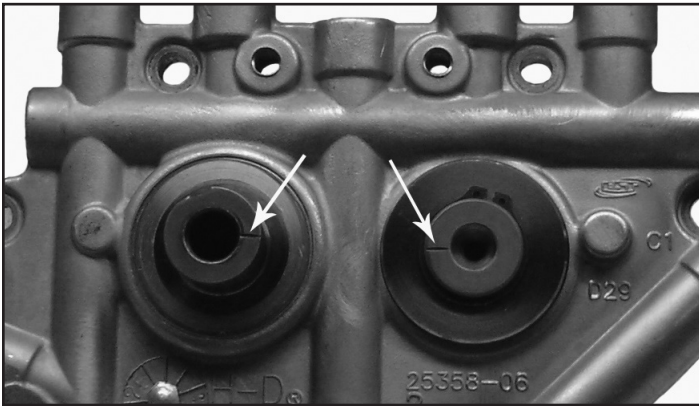

Picture 7

11. Loosely install the support plate screws with a drop of blue threadlock. Alternately tighten the screws (labeled as circles in **Picture 2, Page 3**) to 95 in-lbs. torque following the sequence shown.



Support plate screws that pass through alignment dowels (See positions 1 & 2 in Picture 2) can be easily stripped when applying maximum 120 in-lbs. torque as recommended in factory service manual.

12. Install the oil pump screws into locations (labeled in squares) in **Picture 2**, with a drop of blue threadlock. Screw them into the oil pump until they bottom out and then back them off ¼ turn. Rotate the crankshaft allowing the pump to find its center and alternately tighten the screws in the sequence shown to 45 in-lbs. Torque the screws in the sequence shown to 95 in-lbs. Rotate the crankshaft again checking for any binding in the oil pump gears.
13. Place drive gear key in rear camshaft. Position rear cam drive gear on rear camshaft and key with timing mark outward
14. Apply a drop of red threadlock to threads of 3/8"-24 x 1.75 Grade 8 cam drive gear bolt. Apply a drop of clean engine oil under bolt flange. Using thick washer provided, install cam drive gear bolt, and tighten to 34 ft-lbs. torque. Cams should rotate freely with no binding.

15. Check the inner camshaft gears for proper backlash. Place a dial indicator on a tooth of the rear cam drive gear so that it measures the movement of the teeth of the rear cam drive gear at as close being in line with the direction of rotation as possible. This can be done with a "finger" on the probe as shown in **Picture 10**, or by other arrangement. Dial indicator can be secured with a flex mount or by bolting it to the crankcase at the gear cover surface.

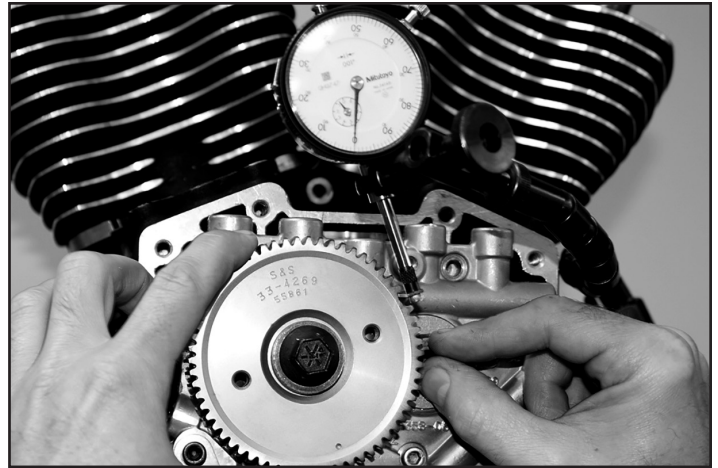

Picture 8

16. Hold the front cam with finger pressure to keep it from rotating, and rock the rear cam drive gear back and forth. Record the amount of gear tooth movement as shown on the dial indicator. Repeat this measurement in four positions at 90° intervals of cam gear rotation. Divide the readings by 2 to correct for the difference in diameters in the inner gears and the outer drive gear. The lowest of the readings after dividing by 2 should be between .0005" and .001". If backlash is not correct, inner rear cam gear must be replaced with either oversized or undersized inner gear. These gears are not included in the cam kit. See line drawing on page 8 for part numbers.

NOTE: Crankshaft and Outer cam drive gears have a light press fit on their respective shafts. Start gears squarely on their shafts and use their mounting bolts to pull them all the way into position.

17. If necessary place the transmission in high gear and turn the rear wheel to rotate the engine until the the crankshaft pinion gear can be installed with the pinion gear timing mark aligned with the outer cam gear timing mark. See **Picture 9.**

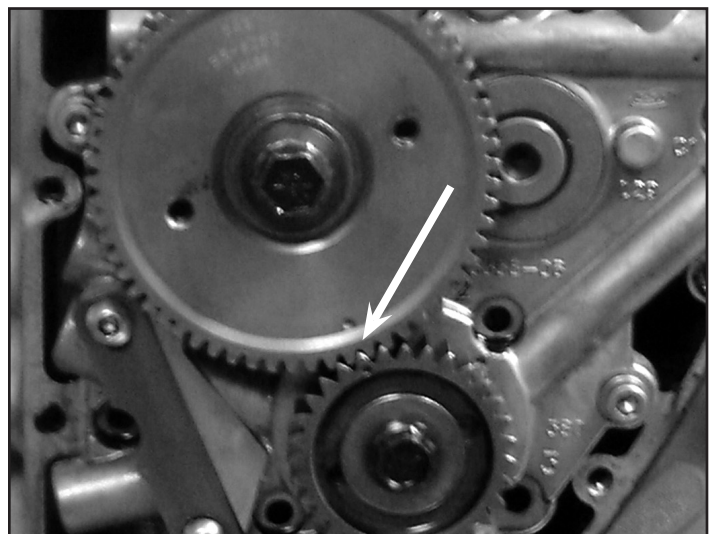

Picture 9

18. Place the crankshaft gear on the crankshaft with the timing mark outward. Apply a drop of red threadlock to threads of $\frac{5}{16}$ -18 x $\frac{3}{4}$ " Grade 8 crankshaft gear bolt provided in kit (PN 33-5240) or obtain one from another source. Apply a drop of clean engine oil under the bolt flange. Using the washer removed in disassembly, install the crankshaft gear bolt and tighten to 25 ft-lbs torque..

NOTE: The axial thrust of the rear cam is controlled by the inner gear collar and the outer gear collar. Check the outer gear to make sure that it is fully seated against the rear cam shoulder. Failure to fully seat the outer gear will cause needle bearing and cam support plate damage.

19. To check backlash between the rear cam outer drive gear and the crankshaft pinion gear, place the dial indicator on a tooth of the rear cam outer drive gear. Rock the rear cam outer drive gear back and forth, and record the indicated backlash. Use the rear tire to turn the engine, and check the lash in four positions at 90° intervals on the pinion gear. Since these measurements are taken directly, they are correct as indicated. Do not divide by 2. Backlash measurements for outer gears may vary depending on the total indicated run-out (TIR) of the pinion shaft. The lowest of the four measurements should be between .0005" and .001", but none should be over .002". If backlash is not correct, pinion gear must be replaced with either an oversized or undersized pinion gear. These gears are not included in the cam kit. See line drawing on page 8 for part numbers. If the lowest backlash readings are within specification and the highest reading is over .002", the pinion shaft of the flywheel assembly has too much runout and must be corrected..

NOTE: Cam drive gears are slightly larger than the stock drive sprockets and need to be checked for interference with the cam cover before proceeding.

20. Press a small amount of kneadable clay or putty on the cam cover mounting boss shown. See Figure 3 below. Carefully hold the cover and cover gasket in the position against the crankcase. Install mounting bolts (4) near the corners of the cover finger tight. Push or tap the cam cover towards the engine.

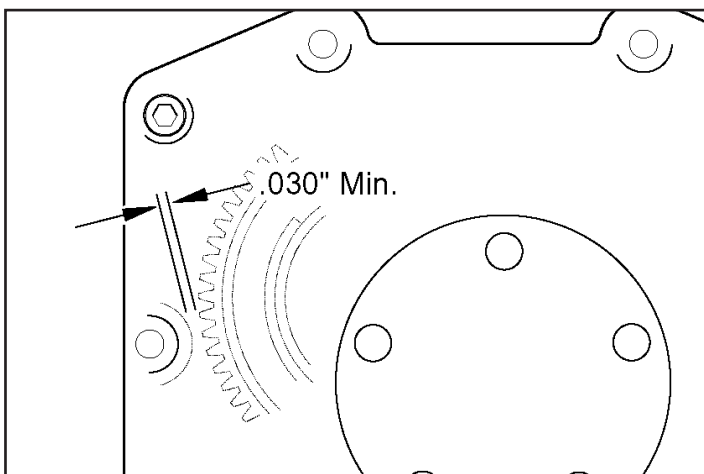

Figure 3

21. Carefully remove the cam cover. Determine the cover to gear clearance by measuring the impression left in the clay by the gear at its thinnest point. Clearance should be .030" or more. If clearance is less than .030", or if the cover contacts the gear, remove only enough material from the cam cover to obtain the correct clearance. Repeat Steps 20 and 21 if necessary.

CAUTION

Be careful not to grind too deeply and break through to the outside of the cam cover. Damage to the cam cover caused by removing too much material is not covered under warranty.

22. Use a new cam cover gasket and install the cam cover. Tighten the cover bolts 90-120 in-lbs torque in sequence shown. See Figure 4.

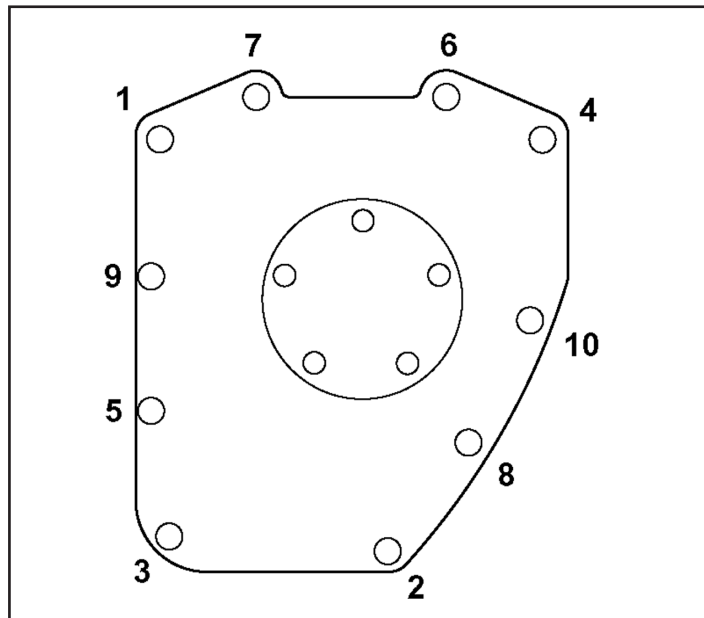

Figure 4

23. Remove magnetic tappet tool or clips to release tappets.
 24. Reinstall pushrods. If using stock non-adjustable pushrods follow the procedure in the factory service manual. If installing adjustable pushrods, follow the manufacturer's instructions.
 25. Replace any remaining parts removed to facilitate gear drive cams installation. Check engine oil level. Start engine and check for leaks.

Special notes on operation of motorcycle with Easy Start camshafts:

- Stock EFI engines require a minimum of 80 PSI cranking compression, checked with the throttle open, for the ECU to fire the spark plugs.
- The easy start cams were designed to work with the compression ratio and displacement combinations that the cam was intended for.
- The engine idle should be set at 1000-1100 RPM.
- If your bike is carbureted, the starting routine may be slightly different, allow yourself time to experiment to find the best method.
- When the engine is turned off, you may hear a slight click. This is the decompression lever resetting. This is normal and does no harm.
- If you allow engine speed to go below 900 RPM, you may hear clicking as the decompression lever starts engaging. Your engine may stall if this happens. If this happens frequently, the idle speed should be adjusted higher
- If the lifters have been disassembled or bled down for any purpose, the starter may have difficulty with the initial start. Although the decompression lo be lifts the lifter body, the lifter is not pumped up and it will not lift the exhaust valve. You may need to remove the spark plugs and crank the engine to get the oil pressure to the lifters.
- There is no service required with these cams. If you ever have the cams out for any reason, inspect the mechanism for wear and verify that the lever operates smoothly

**S&S® GEAR DRIVE CAM REPLACEMENT PARTS
FOR 2007-UP HARLEY-DAVIDSON® BIG TWIN AND 2006-UP DYNA® MODELS**

1. Gasket, Cam Cover (each).....	31-2032-S
2. Pinion Gear	
Standard Size.....	33-4160
Undersized.....	33-4160X
Oversized.....	33-4160Z
3. Outer Cam Gear.....	33-4269
4. Screw SHCS 3/8-24 x 1 3/4".....	50-0132
5. Washer, Flat 3/8" x 1 1/8" x .225".....	50-7056
6. Key, .188 x .150 x .57 (5 Pack).....	106-1348
7. Screw HHC 5/16-18 x 3/4".....	50-0100
8. Outer Oil Hole Cover.....	33-4264
9. Top Oil Hole Cover.....	33-4265
10. Screw BHTS 1/4-20 x 3/4".....	50-0288-S
11. Thrust Washer, .110".....	50-8279
12. Retaining Ring, Bowed #78.....	50-8286-S
13. Needle Bearing (2 Pack).....	31-4499
14. Oil Pump Scavenge O-ring.....	50-8039
15. Inner Gears	
Current Production (Front or Rear)	
Standard Diameter (each).....	330-0487
Undersized (each).....	330-0488
Oversized (each).....	330-0489
Early Production Inner Cam Gears	
Front (each).....	33-4273
Rear Standard Diameter (each).....	33-4274
Rear Undersized (each).....	33-4277
Rear Oversized (each).....	33-4278

Hardware and Gear Kits (Not Shown)

16. Cam Installation Kit (Includes #1, 8, 9, 7, 10, 11, 12, 13).....	106-6068
17. Outer Cam Drive Gear Kit (Includes #2, 3, 4, 5, 6).....	33-4268
18. Cam Gear Kit (Includes #2, 3, 4, 5, 6, 19).....	33-4285
19. Outer Gear Hardware Pack (Includes # 4, 5, 6).....	33-4271P
20. Key, Woodruff .125 x .5 NS.....	50-8223-S

