



Installation Instructions: S&S® Sidewinder® 3⁵/₈" Big Bore Cylinders for 1936–1999 Big Twins

DISCLAIMER:

S&S parts are designed for high performance, closed course, racing applications and are intended for the very experienced rider only. The installation of S&S parts may void or adversely affect your factory warranty. In addition, such installation and use may violate certain federal, state, and local laws, rules and ordinances as well as other laws when used on motor vehicles used on public highways, especially in states where pollution laws may apply. Always check federal, state, and local laws before modifying your motorcycle. It is the sole and exclusive responsibility of the user to determine the suitability of the product for his or her use, and the user shall assume all legal, personal injury risk and liability and all other obligations, duties, and risks associated therewith.

The words Harley®, Harley-Davidson®, H-D®, Sportster®, Evolution®, and all H-D part numbers and model designations are used in reference only. S&S Cycle is not associated with Harley-Davidson, Inc.

SAFE INSTALLATION AND OPERATION RULES:

Before installing your new S&S part it is your responsibility to read and follow the installation and maintenance procedures in these instructions and follow the basic rules below for your personal safety.

- Gasoline is extremely flammable and explosive under certain conditions and toxic when breathed. Do not smoke. Perform installation in a well ventilated area away from open flames or sparks.
- If motorcycle has been running, wait until engine and exhaust pipes have cooled down to avoid getting burned before performing any installation steps.
- Before performing any installation steps disconnect battery to eliminate potential sparks and inadvertent engagement of starter while working on electrical components.
- Read instructions thoroughly and carefully so all procedures are completely understood before performing any installation steps. Contact S&S with any questions you may have if any steps are unclear or any abnormalities occur during installation or operation of motorcycle with a S&S part on it.
- Consult an appropriate service manual for your motorcycle for correct disassembly and reassembly procedures for any parts that need to be removed to facilitate installation.
- Use good judgment when performing installation and operating motorcycle. Good judgment begins with a clear head. Don't let alcohol, drugs, or fatigue impair your judgment. Start installation when you are fresh.
- Be sure all federal, state, and local laws are obeyed with the installation.
- For optimum performance and safety and to minimize potential damage to carb or other components, use all mounting hardware that is provided and follow all installation instructions.
- Motorcycle exhaust fumes are toxic and poisonous and must not be breathed. Run motorcycle in a well ventilated area where fumes can dissipate.

IMPORTANT NOTICE:

Statements in this instruction sheet preceded by the following words are of special significance.



WARNING

Means there is the possibility of injury to yourself or others.

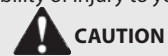

CAUTION

Means there is the possibility of damage to the part or motorcycle.

NOTE

Other information of particular importance has been placed in italic type.

S&S recommends you take special notice of these items.

WARRANTY:

All S&S parts are guaranteed to the original purchaser to be free of manufacturing defects in materials and workmanship for a period of twelve (12) months from the date of purchase. Merchandise that fails to conform to these conditions will be repaired or replaced at S&S' option if the parts are returned to us by the purchaser within the 12 month warranty period or within 10 days thereafter.

In the event warranty service is required, the original purchaser must call or write S&S immediately with the problem. Some problems can be rectified by a telephone call and need no further course of action.

A part that is suspect of being defective must not be replaced by a Dealer without prior authorization from S&S. If it is deemed necessary for S&S to make an evaluation to determine whether the part was defective, a return authorization number must be obtained from S&S. The parts must be packaged properly so as to not cause further damage and be returned prepaid to S&S with a copy of the original invoice of purchase and a detailed letter outlining the nature of the problem, how the part was used and the circumstances at the time of failure. If after an evaluation has been made by S&S and the part was found to be defective, repair, replacement, or refund will be granted.

ADDITIONAL WARRANTY PROVISIONS:

- (1) S&S shall have no obligation in the event an S&S part is modified by any other person or organization.
- (2) S&S shall have no obligation if an S&S part becomes defective in whole or in part as a result of improper installation, improper maintenance, improper use, abnormal operation, or any other misuse or mistreatment of the S&S part.
- (3) S&S shall not be liable for any consequential or incidental damages resulting from the failure of an S&S part, the breach of any warranties, the failure to deliver, delay in delivery, delivery in non-conforming condition, or for any other breach of contract or duty between S&S and a customer.
- (4) S&S parts are designed exclusively for use in Harley-Davidson® and other American v-twin motorcycles. S&S shall have no warranty or liability obligation if an S&S part is used in any other application.

Introduction

Installation of an S&S® big twin 3 $\frac{5}{8}$ " bore stroker Sidewinder® Kit is easy and can be performed by any motorcycle repair shop equipped to do complete engine overhauls.

NOTE: To make installation of S&S Sidewinder series 3 $\frac{5}{8}$ " bore kits easier, S&S has designed several special tools worth considering. They are:

- Part #53-0002—Connecting Rod Checking Pin—helps check piston alignment in cylinder bore.
- Part #53-0020—Degree Wheel Kit—used to check and set crankcase breather timing and ignition timing.
- Part #53-0005 and #53-0009—Crankpin Nut Clearancing Gauges—used to set crankpin nut to crankcase clearance.
- Part #53-0006, #53-0007 and #53-0008—Cylinder Head and Crankcase Boring Fixture and Crankcase Boring Spacers—adapts most boring bars so cylinder heads and crankcases can be bored to fit larger diameter spigots and fire rings on big bore cylinders. Enables qualified operator to bore heads and cases in about an hour after initial setup.

Read instructions thoroughly before starting work. When they are completely understood proceed with installation.

Installation Steps:

Page

1. Bore Heads (shovelhead and panhead only).....	2
2. Relocate Head Bolt Hole (knucklehead only)	3
3. Crankcase Alignment & Cylinder Mounting Studs (All)	4
4. Bore Crankcases (All)	4
5. Clearance Frame (All)	6
6. Modify Crankcases for Oil Returning from Heads (All crankcases 1953 and later) ...	6
7. Crankcase and Piston Skirt Clearancing (All)	7
8. Breather Timing (All)*	10
9. Cam, Lifters and Tappet Blocks (All)	12
10. Connecting Rod Preparation (All)	12
11. Lower End Assembly (All)	13
12. Connecting Rod Alignment (All)*	15
13. Modify knucklehead heads for S&S Oil Return Conversion Kit (knucklehead Installations on 1948 and later Crankcases)	17
14. Piston to Valve Clearancing and Piston Installation (All)	17
15. Final Top End Assemble and Engine Installation (All)	19
16. Timing, Carburetion, Exhaust, Gearing, and Break-in (All)	22

***NOTE:** S&S recommends that engine builder consider performing some steps during initial engine disassembly. Breather timing check requires that most components be assembled, and performing check upon disassembly may save reassembly and cleaning time. While some or all related parts concerned in connecting rod alignment check may be replaced, it is helpful to check original parts combination and note discrepancies which may alter installation of new parts.

Installation

1. Bore Head (shovehead and panhead only)

Procedure for enlarging cylinder head recess to accept larger Sidewinder cylinder flange is as follows:

- A. Bolt boring plate to bench or stand leaving rounded end of plate protrude over edge approximately 6 $\frac{5}{8}$ ".
- B. Clean head gasket surface and bolt head to plate using three 7/16-20 allen head screws furnished with plate. Cylinder head combustion chamber will correctly line up with hole in plate when correct three holes are used for front or rear head.
- C. Center boring bar in hole in plate. Diameter of hole in plate is 3.878" to 3.880" which is identical to dimension of recess to be bored in head.
- D. Bore head to 3.878" to 3.880" diameter by .200" deep. Measure depth from head gasket surface to bottom of cut.

NOTE: We normally take three cuts to bore heads, 3.800" diameter, 3.850" and final size 3.879".

- E. Repeat steps B through D for other head.

NOTE: Cylinder head mounting holes in plate are correctly located to place head fire ring counterbore concentric with head bolt pattern if instructions are followed.

2. Relocate Head Bolt (knucklehead only)

NOTE: Since S&S Sidewinder® cylinders for knucklehead engines are modified S&S big bore cylinders for panhead engines, knucklehead heads must be modified so bolt patterns fit panhead cylinders.

Recommended relocation procedure is as follows:

- A. Determine head bolt hole that must be moved in each head by indexing S&S big bore head gasket around until four out of five holes in gasket line up with four holes in head.
- B. Grind about 1/16" chamfer on edge of hole to provide some room for braze when plug is brazed in place later on.
- C. Retap hole to be plugged with 7/16-14 bottoming tap.

NOTE: Stock knucklehead bolt thread is odd 7/16-16 thread and must be changed to more common 7/16-14, because 7/16-16 tap is expensive and difficult to locate.

- D. Get two 7/16-14 soft bolts (grade 3 or less) from hardware store with sufficient thread to bottom bolt in old hole.
- E. Thoroughly clean hole of all dirt, oil, etc..
- F. Screw bolt in old hole and bottom tightly. Use Loctite® on threads.
- G. Carefully saw or grind off bolt just above gasket surface.
- H. Preheat head and fill chamfered area around bolt with braze.
- I. Machine gasket surface on mill or lathe taking minimum necessary to clean surface.
- J. Bolt head on Sidewinder® cylinder for knucklehead engine using all four stock remaining bolts. Transfer punch new hole position.
- K. Drill and tap new mounting hole to 7/16-14 thread to same depth as four original holes.

NOTE: S&S® Sidewinder kit for knucklehead engines includes eight (8) 7/16-16 stock thread head bolts for stock holes not moved and two (2) 7/16-14 head bolts for two relocated holes.

Alternative relocating procedure is as follows:

NOTE: Although alternative procedure is easier and cheaper and can be performed by any repair shop, recommended procedure eliminates any possibility of bolt coming loose and restores gasket surface which makes for a better head gasket seal.

- A. Determine head bolt hole that must be moved in each head by indexing S&S big bore head gasket around until four out of five holes in gasket line up with four holes in head.
- B. Retap hole to be plugged with 7/16-14 bottoming tap.

NOTE: Stock knucklehead bolt thread is odd 7/16-16 thread and must be changed to more common 7/16-14, because 7/16-16 tap is difficult and expensive to locate.

- C. Get two 7/16-14 soft bolts (grade 3 or less) from hardware store with sufficient thread to bottom bolt in old hole.
- D. Screw bolt in old hole and bottom tightly. Use Loctite® on threads.
- E. Carefully saw or grind off bolt just above gasket surface. Do not damage gasket surface.



CAUTION

Saw and/or grinding marks on head gasket surface may result in head gasket failure and possible damage to engine components.

- F. Carefully hand file or grind bolt flush with gasket surface.
- G. Bolt head on Sidewinder cylinder for knucklehead engines using all four stock remaining bolts. Transfer punch new hole position.
- H. Drill and tap new mounting hole to 7/16-14 thread to same depth as four original holes.

NOTE: S&S Sidewinder kit for knucklehead engines includes eight (8) 7/16-16 stock thread head bolts for stock holes not moved and two (2) 7/16-14 head bolts for two relocated holes.

3. Crankcase Alignment and Cylinder Mounting Studs (All)

NOTE: Some crankcase base gasket surfaces on which cylinders are positioned do not align properly. This usually occurs when crankcase halves used are from different crankcase assemblies and were not paired and machined together at the factory. It is recommended to check for crankcase misalignment even if crankcase halves are correctly matched to prevent potential oil leaks and other mechanical problems.

CAUTION

Mismatched gasket surfaces due to improperly aligned crankcase halves may cause unwarranted stress on cylinder base flanges which could result in cylinder flange failure.

- A. Clean cases thoroughly and assemble both halves without flywheels. Tighten all case bolts as in final assembly.
- B. Place straight edge ruler across base gasket surface. **See Picture 1.**

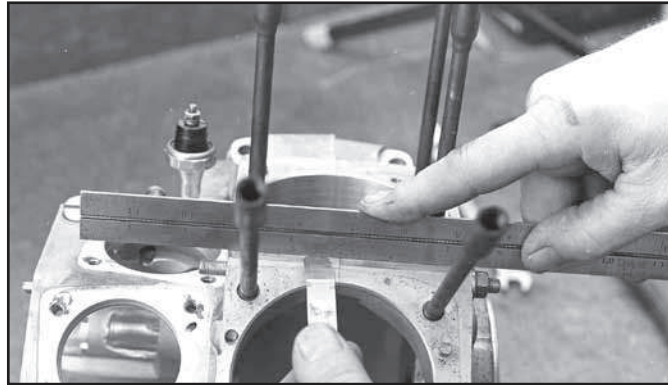

Picture 1

- C. If any misalignment exists, remove cylinder base studs and place masking tape over cam and mainshaft bearings to keep chips out.

NOTE: Early Harley-Davidson® Evolution® crankcases equipped with female style studs must be changed to later male style studs because S&S Sidewinder cylinders are designed for later design studs and head bolts. Consult your Harley-Davidson® service manual for proper removal and installation procedures.

CAUTION

Be careful when removing studs so as not to damage threads in cases. If stud does not come out easily, carefully heat case around studs as heat may help loosen them. Damaged studs may cause stress risers which can lead to stud failure and possible damage to engine components.

- D. Place cases squarely in mill and machine gasket surface taking minimum necessary to clean surface.
- E. Knucklehead, panhead, shovelhead engines- If stock cylinder studs are to be used, thoroughly clean and reinstall to 1.175" to 1.225" measured from top of stud to gasket surface. If studs are provided in kit, install to height that equals: (thickness of cylinder base flange) + (base gasket) + (cylinder base plate) + (washers) + (base nut).

NOTE: Use Loctite® Stud and Bearing Mount to secure studs to ensure they don't turn out during future disassembly.

- F. Evolution engines—Consult your Harley-Davidson® service manual for proper stud installation procedure and stud installation height.

4. Bore Crankcases (All)

NOTE: Early panhead crankcases, 1948–1952, have cylinder head oil feed passageways drilled closer to cylinder spigot bore. When boring cases for larger diameter spigots, bore cut may break into passageway. It is recommended to use aftermarket crankcases if at all possible. Aftermarket cases are stronger, enhance engine life because of Timken® bearing design and eliminate breaking into oil passage because they are drilled differently.

CAUTION

Hole in oil feed passageway to cylinder heads will cause loss of oil pressure to heads resulting possible damage to rocker arms and/or other engine components.

NOTE: Boring cylinder spigot holes in cases to accommodate big bore cylinders will machine a notch on center case bolt and bolt immediately to rear of rear cylinder. These bolts must later be placed in same position as when machined to prevent unwarranted stress on cylinder base spigots.

 **CAUTION**

Unwarranted stress on cylinder base spigots may cause possible damage to cylinders, pistons and/or other engine components.

NOTE: To make repositioning these studs easier later, we recommend sawing slots in ends so that they may be turned with a screwdriver after installation in cases.

Perform following procedure to bore crankcases:

- A. Hacksaw screwdriver slot .050" deep in top center case bolt and bolt immediately to rear of rear cylinder.
- B. Clean cases thoroughly and assemble using all case bolts.
- C. Position slots in center and rear studs so slots are perpendicular to or parallel with base gasket surface or lined up with some easily identifiable point on case and tighten all case bolts as in final assembly.
- D. Place masking tape over both ends of camshaft and mainshaft bearings to keep out chips.
- E. Bolt boring plate to bench or stand leaving squared end of plate protrude over edge approximately 7.
- F. Procure four nuts from local hardware store, $\frac{7}{16}$ -20 thread for early cases and $\frac{3}{8}$ -16 thread for 1984-'99 models, and bolt cases to plate using all four studs. Big twin 1984-'99 cases with late style male studs must be spaced away from plate by using boring spacers, Parts #53-0007 and #53-0008. Be careful not to damage studs.

 **CAUTION**

Damaged studs may cause stress risers which can lead to stud failure and possible damage to engine components.

- G. Center boring bar head in cylinder spigot bore in crankcases, not hole in plate.

NOTE: Some bar centering tools are pointed which may dig into soft crankcase aluminum. Be careful when centering bar. For greater accuracy center once, then rotate bar 90° and retap-center.

- H. Shovelhead and Harley-Davidson® Evolution® cases - bore hole to diameter of 3.878" to 3.880" by 1 $\frac{5}{8}$ " deep. Measure depth perpendicular from cylinder base gasket surface. Knucklehead and panhead cases - bore hole to diameter of 3.878" to 3.880" by 1 $\frac{5}{8}$ " deep.

NOTES:

- We normally take three cuts to bore cases, 3.800" diameter, 3.850" and final size 3.879". If you machine into boring plate on final cut, this is of no consequence since hole in plate is never used as machining reference point.
- Boring to a shallower depth leaves more material in older, weaker crankcases. This also minimizes possibility of breaking into oil supply passages to heads on panhead cases. If cutter breaks into passage, thin wall brass modeling tubing (available at many hobby shops) may be used to repair damage. To repair damage using this method, perform following steps:
 1. Grind 45° angle on end of tubing to be inserted in case and remove burrs.
 2. Press angled end of tubing into passageway at base gasket surface until tubing bottoms in passageway and seals damaged area.
 3. Locate hole that supplies damaged passage and blow air into it to be sure passage is clear. Rotate tubing to point where air pressure escaping is greatest.
 4. When air passes freely, carefully cut off tubing flush at base gasket surface and debur.
 5. Peen tubing down that is exposed in damaged area so that it does not protrude above machined surface of crankcase spigot hole. | Do not overpeen tubing to where passage is sealed off.

 **CAUTION**

A restriction in oil feed passageway to cylinder heads may cause a loss of oil pressure to heads resulting possible damage to rocker arms and/or other engine components.

- I. Repeat steps F to H for other spigot bore.

5. Clearance Frame (All)

NOTE: Piston stability in cylinder bore is enhanced by using pistons with long skirts. S&S® Sidewinder® kits are designed with this in mind regardless of stroke used. As stroke gets longer cylinder height/engine height must be increased. Convenient frame fit, stock rocker cover to frame tubes and/or rocker cover to gas tank clearances have to be sacrificed. Hence, all Sidewinder® kits with taller than stock cylinders require checking in these areas. We have found that engines with cylinders up to .125" (1/8") taller than stock will usually clear.

To check and clearance frame, perform following steps:

- A. After crankcase boring operation, leave cases together and bolt cylinders with base gaskets in place. If base plates are to be used, be sure they are installed also.
- B. Bolt heads on cylinders with head gaskets in place using two bolts and washers provided for each head. Harley-Davidson® Evolution® heads and cylinders are held in place simultaneously with head bolts provided.
- C. Install rocker boxes, with gaskets, etc.
- D. Slip mocked up engine in place in frame.
- E. On rigid mounted engines, rear rocker cover may contact frame tube(s).

NOTE: S&S® recommends there be .060" minimum clearance between engine and other chassis components on rigid frame installations. Rubber mounted engines require .125" clearance minimum. Up to .060" or .070" may be ground from rocker box cover in some areas for clearance. If cover is ground, be careful not to break through.

CAUTION

Excessive material removed from rocker cover may damage cover causing oil leaks.

WARNING

Excessive material removed from frame may cause structural damage and possible failure resulting in personal injury to you or others near you.

- F. Hold each gas tank in place separately. Note and mark points of contact with magic marker. Some models may be worse than others. Grind rocker cover if necessary, but be careful not to break through cover as they are thin in some places. See step E above. Obtain at least .060" minimum clearance for rigid mounted engines and .125" minimum for rubber mounted engines.

NOTE: Additional room may be gained by slotting front gas tank mounting tabs if rocker cover clearancing is inadequate.

CAUTION

Grinding and/or peening gas tank may damage tank causing leaks.

WARNING

Unwarranted gasoline leaks from gas tanks may overflow on surrounding area where it could catch fire possibly causing personal injury to you or others near you.

6. Modify Crankcases for Oil Returning from Heads (All Crankcases 1953 and later)

Crankcases 1953 to 1984

NOTE: This operation is necessary on any Sidewinder® installation for knucklehead, panhead or shovelhead engines where oil from cylinder heads is being returned to crankcases via oil return passageway in cylinders.

While cases are still bolted together, perform following steps:

- A. Place cylinder base gasket on cases and mark and centerpunch oil return holes. Make certain you have gasket on correctly by checking oil hole location with each Sidewinder® cylinder.
- B. Drill 1/4" diameter holes perpendicular to gasket surface 5/16" deep. **See Figure 1, next page.**

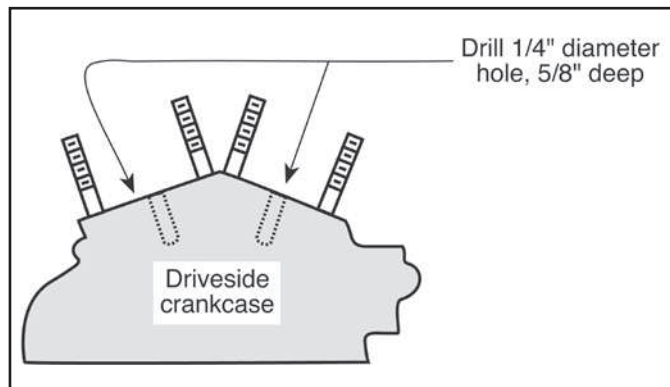

Figure 1

- C. Disassemble crankcases and bolt front and rear cylinders to drive side crankcase half.
- D. Drill through oil return hole in cylinder spigots into crankcase approximately $\frac{5}{16}$ " deep to connect with holes previously drilled using $\frac{1}{4}$ " diameter taper length drill.
- E. Unbolt cylinders and remove from crankcase. Use file to break thin web of material at gasket surface. File slots to width of drilled holes.

Crankcases 1984 to 1999

NOTE: Oil return passageways in Sidewinder® cylinders for Harley-Davidson® Evolution® engines are moved out slightly as compared with stock oil return holes to accommodate $3\frac{5}{8}$ " bore. This creates misalignment between cylinder oil return passage and crankcase oil return passage.

To modify cases and return oil properly, perform following steps:

- A. Place cylinder base gasket on cases and note amount and direction of return hole mismatch.
- B. Chamfer edge of hole accordingly at minimum of 45° angle to insure adequate flow.

7. Crankcase and Piston Skirt Clearancing (All)

Crankpin Nut Clearance

Bosses on inside of cam side crankcase half must be clearanced for crankpin nut. **See Picture 2.**

NOTE: Crankpin nut will usually clear on cases of 80" shovelhead and Harley-Davidson® Evolution® engines when $4\frac{1}{4}$ " or $4\frac{3}{8}$ " stroke is used. When stroke $4\frac{1}{2}$ " or longer is used, nut will usually hit. S&S® recommends all cases be checked no matter what stroke is used. S&S Crankpin Nut Clearancing Gauge, Part #53-0005, for cases 1958 and later, and Part #53-0009 for cases 1957 and earlier are designed to mark crankcase that allows sufficient crankpin nut clearance for specific stroke to be used.

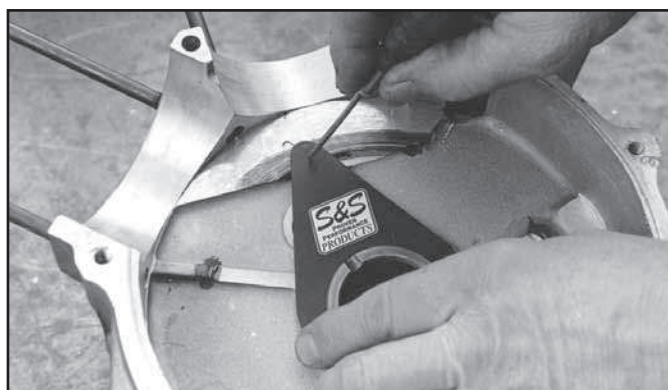

Picture 2

If S&S gauge is not available, perform following procedure:

- A. Paint bosses with machinist's blue.
- B. Use divider to scribe arc on blued bosses. **See Figure 2.** Formula for spread of divider is:

$$\text{Distance} = (\frac{1}{2} \text{ Flywheel Stroke}) + (\frac{1}{2} \text{ Diameter of Crankpin Nut Measured Across Points}) + (\frac{1}{16} \text{ Clearance}) - (\frac{1}{2} \text{ Outside Diameter of Race})$$

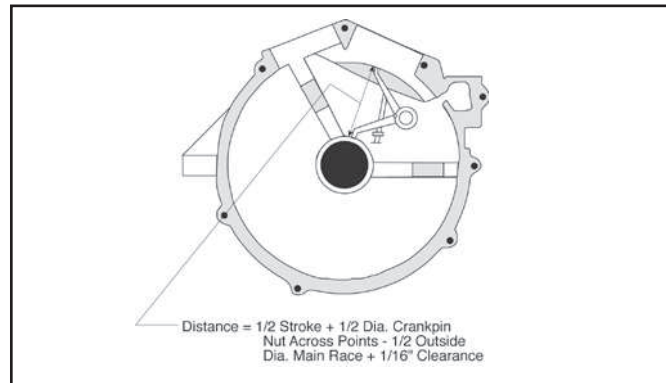

Figure 2

NOTE: On panhead engines, above procedure is recommended to insure removal of minimum material necessary.

CAUTION

Early panhead cases are not as strong and are machined with oil supply passageways to heads closer to surface of boss. Removal of excessive material may weaken thinner cases and/or break into oil passage.

- C. Place masking tape over both ends of camshaft and mainshaft bearings to keep out chips.
- D. Grind shaded areas to adjacent machined depth.
- E. Mock up right side flywheel in crankcase half with mainshaft and crankpin installed with bearings, thrust washers, etc. in place.
- F. Rotate flywheel and note any contact.
- G. If flywheel does not rotate freely, check contact areas and grind more clearance.
- H. Repeat procedure until sufficient clearance is obtained.

NOTE: A minimum of $\frac{1}{16}$ " clearance is required.

CAUTION

Insufficient clearance between crankpin nut and crankcase will cause contact and may damage components.

Connecting Rod Clearance

Front and rear of flywheel cavity inside crankcases and cylinder spigots must be clearanced for connecting rods. **Picture 3, next page,** shows rear side of flywheel cavity.

NOTE: Clearance must be checked and filed on front side also.

Procedure to check these points is performed as follows:

- A. Mock up right side flywheel in crankcase half with mainshaft and crankpin installed with bearings, thrust washers, etc. in place.
- B. Assemble pistons without rings on their proper connecting rods, and place connecting rods on crankpin. Installation of wristpin clips is not necessary.

NOTE: If pistons have piston to piston clearance notches ground on thrust face edges, place notches toward center of engine. Consult piston installation instructions included with pistons for proper piston direction placement.

- C. Install both cylinders and secure each with one nut.

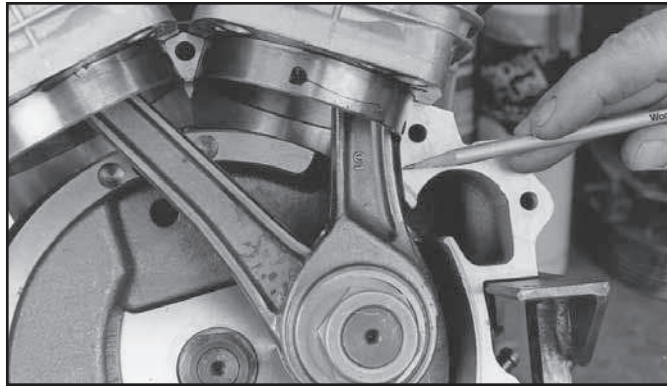

Picture 3

NOTE: If base plates are to be used, be sure they are in place.

- D. Rotate flywheel until rods contact areas to be clearanced. Note angle that must be filed.
- E. Disassemble cylinder and connecting rods and file crankcase and cylinder spigot for clearance.

NOTE: A minimum of $\frac{1}{16}$ " clearance is required.

- F. Reassemble and check clearance.
- G. Mark and grind other crankcase half to identical clearance.

⚠ CAUTION

Insufficient clearance between connecting rods and crankcases will cause contact and damage to components.

Piston Clearance

Pistons must be clearanced to avoid contact with each other and with flywheels. **See Pictures 4, below left, and 5, below right.**

NOTE: Material removed from pistons for clearancing purposes will not adversely affect flywheel balance.

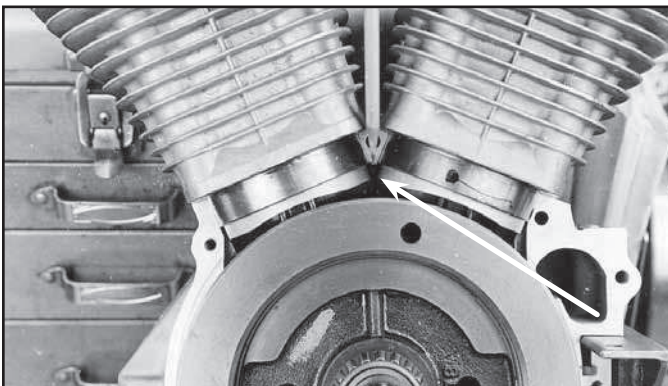

Picture 4

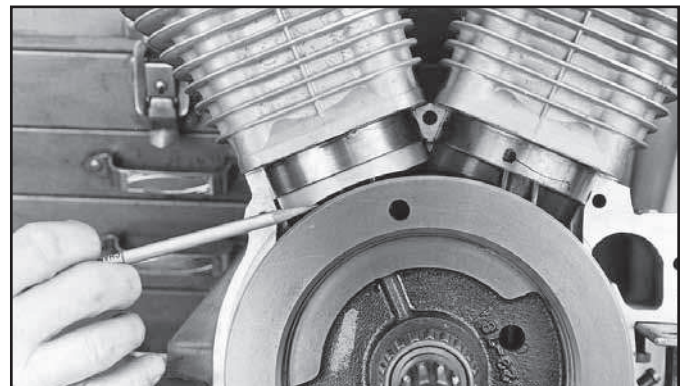

Picture 5

NOTE: Some S&S® kits utilize flywheels with diameters smaller than stock (stock big twin flywheels are 8½"). This is done to maximize piston skirt length. Our experience has shown that while it is not absolutely necessary to build up flywheel scraper, it is recommended that flywheel scraper be built up to within .008"-.010" of flywheels to optimize removal of oil from crankcase cavity.

⚠ CAUTION

Insufficient clearance between pistons and pistons and flywheels will cause contact and damage to components.

Piston to Piston Clearance

- A. Perform steps A through C in "Connecting Rod Clearance" on page 8
- B. Rotate flywheel to position where pistons are closest to each other. **See Picture 4, page 9.**
- C. Check clearance between pistons.

NOTE: A minimum of $\frac{1}{16}$ " clearance is required.

- D. Disassemble cylinders and pistons, and carefully file edge of piston skirts until clearance is obtained.
- E. Reassemble and check clearance.

Piston to Flywheel Clearance

- A. Perform steps A through C in "Connecting Rod Clearance" on previous page.
- B. Rotate flywheel to position where front piston is closest to flywheel. **See Picture 5, page 9.**
- C. Check clearance between piston and flywheel.

NOTE: A minimum of $\frac{1}{16}$ " clearance is required.

- D. Disassemble cylinder and piston, and carefully file piston skirt until clearance is obtained.
- E. Reassemble and check clearance.
- F. Repeat procedure for rear piston.

8. Breather Timing (All)

To maximize efficiency when scavenging oil from flywheel cavity in big twin engines, it is necessary to check and usually modify crankcase breather timing.

NOTES:

- Breather timing can be checked after other crankcase clearancing is done or during initial disassembly.
- Early crankcase breather opening is a rough cast elliptical hole. Later vintage crankcases have a breather opening that is square.
- Objective of this step is to modify cases so that hole in cases is located in same position as hole in breather gear with opening and closing sides of hole in case in correct location for proper breather timing.
- S&S Part #53-0020, Degree Wheel Kit, was designed to aid in checking breather timing. Procedures below assume an S&S degree wheel is used.
- S&S recommends grinding hole to maximum timing specifications. If there is any doubt and timing falls within specs, leave breather opening alone. **See Figure 3** for breather timing specifications.

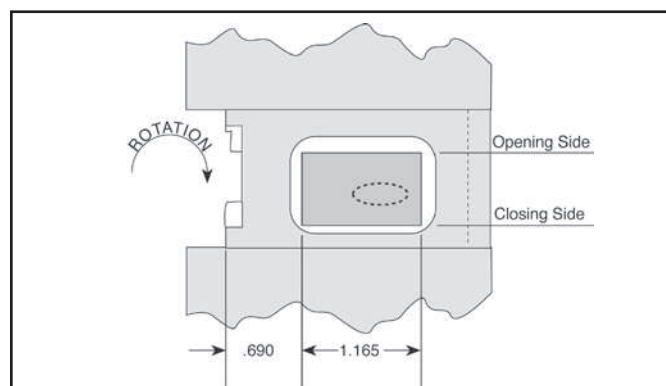

Figure 3

CAUTION

Improper breather timing causes poor oil scavenging from flywheel cavity and incorrect crankcase air pressure. These conditions may cause unwarranted engine oil leaks around gaskets and seals and probable oil burning due to oil blow by past piston rings. Removal of excessive material from breather gear opening is irreversible and damage to crankcases may result.

To check and modify breather timing perform following steps:

- A. Bolt degree wheel pointer to drive side crankcase half using center case stud and nut. Position pointer towards sprocket shaft.
- B. Install degree wheel assembly on sprocket shaft. Rotate flywheel assembly so front piston is at TDC, top dead center. Position degree wheel on sprocket shaft so pointer indicates 0° TC, top center, and tighten set screw.
- C. Rotate flywheels in normal direction of travel to 10° before TC as in Picture 6. Observe breather gear and hole in crankcase through tappet block opening to determine hole in breather gear and hole in case relationship.
- D. Rotate flywheels to 10° after TC. Again note relationship. If edge of hole in gear appears in hole in crankcases during this span of degrees, then cases have proper opening specs. If not, then opening side of hole in cases must be ground. Grind hole to 10° before TC, maximum timing specifications.
- E. Rotate flywheels to 55° after BC, bottom center. Observe breather gear and hole in crankcase to note their relationship.
- F. Rotate flywheels to 75° after BC and note relationship. **See Picture 7, below left.** If back edge of hole in gear disappears from view during this span of degrees then cases have proper closing specs. If not, then closing side of hole in cases must be ground. Grind hole to 75° after BC, maximum timing specifications.
- G. Note location of hole in gear as opposed to hole in crankcases. **See Figure 3, page 10.** Grind hole in cases so location matches holes in gear with respect to where toothed portion of gear hits cases. **Picture 8, below right,** shows finished breather gear opening.

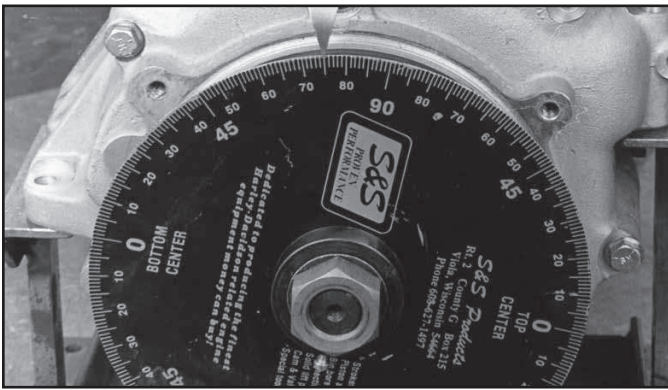

Picture 7

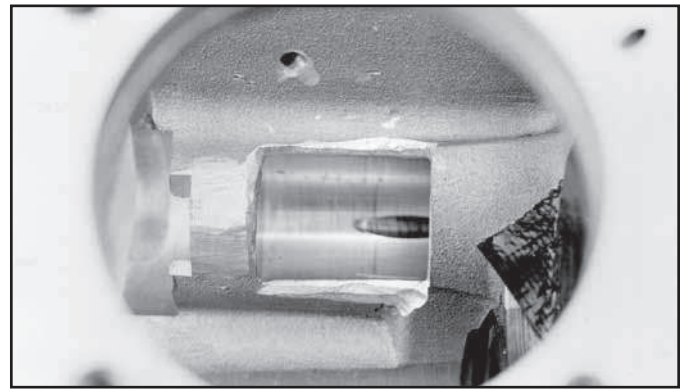

Picture 8

H. Optional Step

NOTE: This procedure increases area that air and oil have to pass from breather gear cavity to gear side.

To modify screen:

- a. Early gears—Remove clip that holds screen in place.
- b. Early gears—Turn screen so it covers hole made by removing clip.
- c. Early gears—Spot weld screen in place.
- d. All gears—Drill all holes in screen as large as possible without weakening screen.

NOTE: To further maximize breather efficiency some engine builders modify or remove screen in breather gear.

CAUTION

Breather gear screen stops foreign material from getting into gear side cavity where material could possibly stop oil pump and/or damage other parts. No oil to engine will result in damage to engine components.

9. Cam, Lifters and Tappet Blocks (All)

NOTES:

- *Big inch, stroked engines with compression ratios of 8.5:1 or more respond well to higher lift, longer duration cams. Engines with lower compression ratios should have shorter duration cams. S&S® offers cams for all big twins, except the knuckleheads that we have run in our test engines. We recommend their use along with S&S high performance valve springs and retainers. These components along with other valve train parts are available in kits that not only satisfy most any degree of rebuilding required but also make valve spring spacing and high lift cam installation an easy job. If you are using a high lift camshaft perform any required head work and valve spring spacing per manufacturer's instructions.*
- *Sidewinder® built using knucklehead 1936–47 cases may use any aftermarket knucklehead cam such as an Andrews "S" or "K" grind. Knuckleheads installed on later crankcases, 1948 and up, should use cams such as "575" Sifton. In panhead or shovelhead 575's lift is much higher, but when used with knuckleheads, lift is only .400" since knucklehead rocker arm ratio is 1:1.*
- *Sidewinder kits for Harley-Davidson® Evolution® engines have been tested using both solid lifters and hydraulics. We recommend using hydraulic assemblies in all Evolution® applications. They are far superior to early style panhead/shovelhead assemblies and hold up extremely well under most conditions. To maximize efficiency and reduce potential valve float in high rpm situations, S&S Hydraulic Lifter Limited Travel Kit should be used in all late model performance applications.*
- *1953 and later, panhead and shovelhead strokers with solid lifters should have tappet block hydraulic lifter oil feed holes plugged to prevent excess oil escaping above lifters from filling pushrod tubes causing potential oil leaks.*

To plug tappet block oil feed holes, perform following steps:

- A. Starting at gasket surface end of oil feed passageway in tappet block base, thread 8-32 tap into oil passage hole. Turn tap until tap end just starts to enter cam follower hole.
- B. Screw 8-32 x 3/16" allen head set screw in passageway until it stops.
- C. Perform steps A and B to other tappet block.

NOTE: If hydraulic lifters are ever reinstalled, plugs must be removed.



CAUTION

Restricted oil flow to hydraulic lifter assemblies causes lifters to operate with improper oil pressure which may damage them or other valve train components.

10. Connecting Rod Preparation (All)

NOTE: If S&S® connecting rods are used, follow instructions that accompany rods since rod preparation below has already been done. See S&S big twin rod information section on page 15.

If S&S rods are not used, perform following steps:

- A. To insure adequate oil on sides of rods and matching thrust surfaces of flywheels, S&S recommends that four grooves be ground on each side of both front and rear connecting rods. **See Figure 4, below.** Make these grooves .020" to .030" deep and .030" to .040" wide and should be ground 90° from each other. After making grooves, remove all sharp edges and burrs with emery cloth.
- B. With rods assembled, measure distance between rods at closest points in wristpin holes. If measurement exceeds 2.950" as shown in **Figure 4, below,** grind female rod at points where male rod makes contact to achieve sufficient clearance.

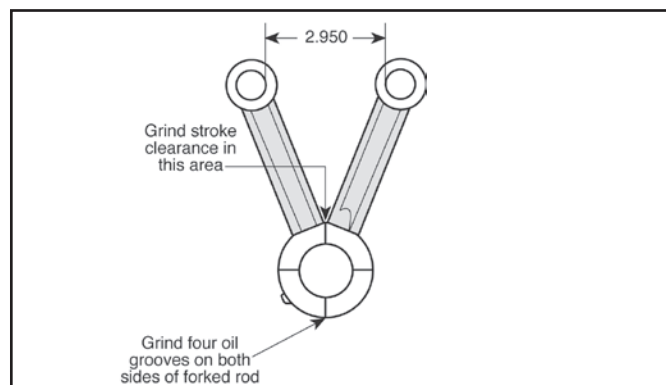

Figure 4

NOTE: Rods clearanced to this dimension provide adequate clearance for strokes up to and including 5". Do not remove any more material than is necessary to obtain required clearance.

 **CAUTION**

Inadequate clearance between rods or too much clearancing on rods will cause unwarranted stress on connecting rods, rod bearings, pistons, etc. resulting in possible failure of one or all of these parts.

- C. Thoroughly clean all parts to remove dirt, filings, etc.

 **CAUTION**

Burrs, dirt, filings, etc. left on connecting rod components may circulate in oil damaging other parts possibly causing engine failure.

11. Lower End Assembly (All)

NOTES:

- S&S flywheels for big twin engines with serial numbers that start with a letter or those numbered 1382 or higher are made from closed die, heat treated, steel forgings. They do not have connecting rod thrust washers like earlier S&S flywheels, because present flywheel material is harder than thrust washers previously used.
- S&S flywheels come with either one or three timing marks. A single timing mark represents front cylinder. On flywheels with three timing marks, an "F" stamped by a mark means front cylinder, an "R" means rear cylinder and a "TF" means top dead center front cylinder. In both cases, when front or rear mark is placed in center of timing hole it means that that cylinder is timed at 35° before top dead center. We recommend that big inch engines for big twin be timed at 35° initially. See Step 12, "Ignition Timing."
- Usually S&S flywheels are balanced before leaving our facility. Some customers prefer to do their own balancing or to have another balancing shop do the work for them. This is acceptable in most cases. However, we have had some bad experiences with dynamically balanced flywheels that have forced us to void our guarantee if flywheels have been balanced in this fashion.

 **CAUTION**

Flywheels assembled improperly prior to being dynamically balanced may sustain irreversible damage to mainshaft and crankpin tapers during actual balancing. S&S voids its guarantee if flywheels have been balanced in this fashion.

- Assembling flywheels, mainshafts and connecting rods can be easy or difficult. Degree of difficulty is determined by builder technique and parts at his disposal. While S&S flywheels have been noted for their easy truing qualities, they can be difficult to true if a defective part is used that should have been detected before assembly.
- Cleaning parts prior to and during assembly and keeping parts clean after final assembly are imperative to minimize contaminants that may circulate in oil and shorten engine life. Many parts can be cleaned with soap and water first. Then, reclean all internal parts and gasket mating surfaces using high quality solvent that does not leave any harmful residues. en, reclean all internal parts and gasket mating surfaces using high quality solvent that does not leave any harmful residues. Be sure to read and follow manufacturer's instruction label before use. Use drills and compressed air to clean all oil passageways of dirt, filings, etc. whenever possible. During actual final assembly, recoat all internal parts with high quality engine oil.

 **CAUTION**

Manufacturing chips, dirt, and/or other contaminants circulating in engine oil may possibly damage engine components resulting in shorter engine life and possible engine failure.

WARNING

- Some solvents, degreasers, gasoline and other chemicals are harmful to skin, eyes and other body parts. Many items are flammable and present a fire hazard. Read manufacturer's instruction label for proper use. Use in well ventilated area and wear protective clothing when using them to avoid personal injury.
- Compressed air and particles dislodged by compressed air are harmful to eyes and body. Wear protective goggles when using compressed air and always direct air stream away from body parts such as hands and eyes and other people near you.

Perform following steps when assembling flywheels:

- A. Thoroughly clean all parts to be used. This includes mainshafts, main bearings, connecting rods, rod bearings, crankpin nut retainers and screws if they are to be used, keys and flywheels including tapers and keyways.

CAUTION

Burrs, dirt, filings, etc. left on flywheel assembly parts may circulate in oil damaging other parts possibly causing engine failure.

- B. Check both mainshafts between centers for taper surface to bearing surface concentricity. Make sure centers on shafts are clean beforehand. If tapers and bearing surfaces are concentric with each other and with center, then truing will be easier. **See Picture 9, below.**

NOTE: Stock specs. allow maximum of .001" runout between taper and bearing surfaces. S&S® prefers to see .0003" or less with an absolute maximum of .0005". S&S shafts are .0003" or less.

- C. Inspect keyways and oil holes for burrs in flywheels and remove if necessary.
- D. With key in shaft, insert into respective tapered hole in flywheel and check to see that key does not bottom in groove. If key bottoms out, file flat side of key, not rounded side, until shaft with key in place fits in flywheel without bottoming out. Check crankpin and crankpin key also.

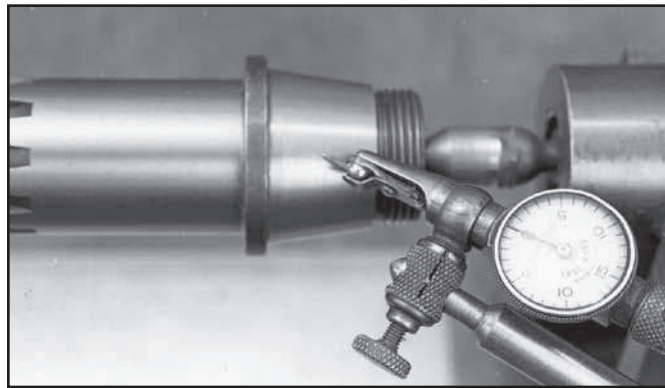

Picture 9

- E. Reclean mainshaft tapers, crankpin and flywheel tapers with lacquer thinner.
- F. Assemble mainshafts in respective flywheels. Coat taper and threads of each shaft with green Loctite® during assembly. Install crankpin in camside flywheel using Loctite® also. Tighten all nuts to at least factory torque specs minimum. When S&S shafts are used, follow instructions included with them.

NOTE: Use of a torque multiplier in conjunction with a professional quality torque wrench will make it easier to achieve high torque accurately.

After right side flywheel, pinion shaft and crankpin are assembled, blow air through pinion shaft oil feed hole to check for blockage.

CAUTION

Partially or completely blocked oil feed passageways may cause irreversible damage to bearings and other engine components.

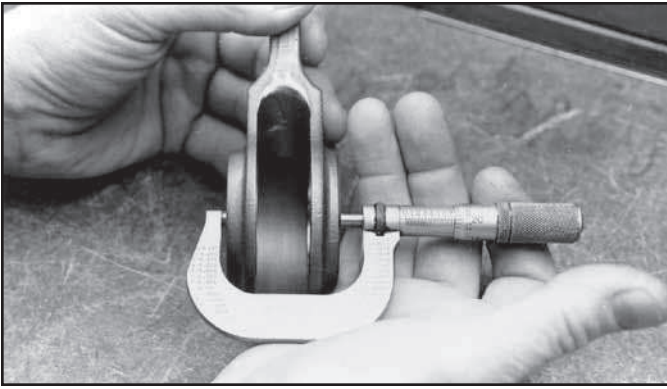

Picture 10

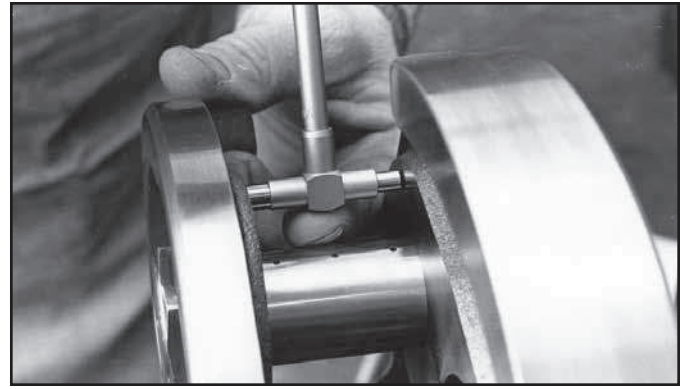

Picture 11

- G. Measure width of female rod on crankpin end. **See Picture 10, above left.** Measurement should be 1.743" to 1.745".
- H. Assemble left and right flywheels and moderately snug nuts. Do not worry about them being true. Measure distance between connecting rod thrust pads. **See Picture 11, above right.**

NOTE: S&S recommended rod side play is .015" to .035". $\text{Rod Side Play} = (\text{Distance from Pad to Pad}) - (\text{Female Rod Width})$

CAUTION

Incorrect connecting rod side play may cause excessive rod side thrusting and potential damage to rods, flywheels and other engine components.

If difference is less than .020", female rod must be ground on sides as final tightening will pull wheels closer together. Rod side play diminishes about .015" when crankpin nut is final tightened. Take equal amounts off each side if amount to be removed is more than .010". If there is no rod side play try different crankpin. If rod side play is more than .035", try different crankpin. We have run side play of as much as .045" without serious consequences. If side play is excessive and different crankpins do not correct problem, contact your S&S Tech representative.

NOTE: If material is removed from sides of female rod, overall width of bearing cages must be reduced so bearings and cages are free to float with rods without contacting flywheel thrust pads. Bearing cage side clearance of .008 to .020 less than rod width is recommended.

CAUTION

Connecting rod bearing and cage assemblies that are wider than female rod may become damaged upon contact with flywheel thrust pads. Damaged rod bearing assemblies and/or foreign material from damaged components circulating in oil could cause further destruction and possible failure of other engine parts.

- I. Finish assembling flywheels and rods. Flywheel assemblies machined for stock 1972 to early 1981 sprocket shaft may be more difficult to true because of the 8½° sprocket shaft taper. Following above procedures will help diagnose problem if difficulty should arise.

12. Connecting Rod Alignment (All)

After flywheel assembly is installed in crankcases, rods must be checked for straightness.

NOTES:

- The purpose of this procedure is to correct for machining tolerance discrepancies in components which may lead to pistons not running true in cylinder bores. While rods may be straight and true, it is sometimes necessary, to bend them to correct for these machining discrepancies. Do not bend rod by using tool in wristpin hole as this method may distort wristpin bushing. We also feel that using a piston in lieu of a checking pin may prove inaccurate due to variations in lengths of piston skirts from one side of piston to the other.
- All engines should be checked upon disassembly for incorrect piston alignment. This applies to those which are receiving new pistons as well as those being completely rebuilt. Observe pistons for wear spots on sides above top compression ring. If one side near wristpin is worn clean while side opposite is carboned up, then piston was not running straight and true in cylinder bore. Piston will also generally show diagonal wear pattern on thrust faces of skirts and possibly signs of connecting rod to wristpin boss contact inside piston.
- We feel that not enough emphasis is given to checking piston alignment in cylinder bore. Proper piston alignment means connecting rods will thrust to sides less minimizing added stress on pistons, rings, rod bearings and other related parts.
- S&S® Rod Checking Pin, Part #53-0002, was designed to help perform this procedure. It may also be necessary, to fabricate a rod bending tool as illustrated in **Figure 5, next page.**

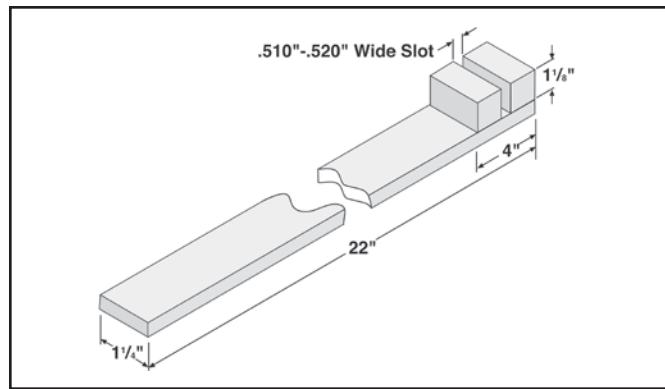

Figure 5

CAUTION

Pistons which do not run true in cylinder bores may cause excessive connecting rod side thrusting. This in turn may lead to premature ring, piston, connecting rod and rod bearing wear and eventual failure of these parts.

Checking Pin Procedure

- A. Insert checking pin into wristpin hole. Place strips of paper between checking pin and crankcase cylinder gasket surface and apply slight downward pressure to wristpin end of rod by rotating flywheels. Pull papers out slowly. Drag on papers should be equal.
- B. Rotate flywheels in opposite direction until checking pin contacts cylinder gasket surface again. Repeat procedure to rod again. If drag on papers is equal no bending is required. If one paper is loose, use rod bending tool to tweak rod in direction of loose paper and recheck. **See Picture 12, below left.**
- C. Repeat checking and bending procedure for other rod.

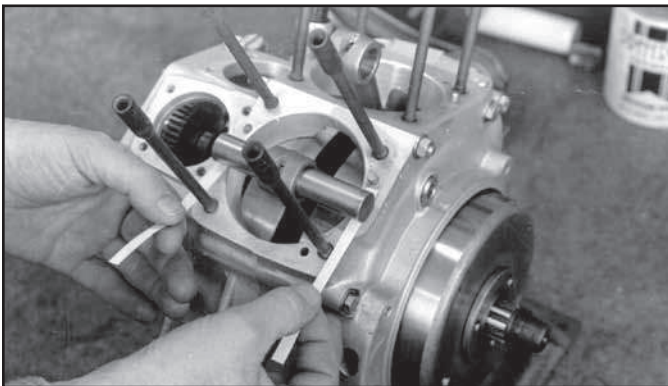

Picture 12

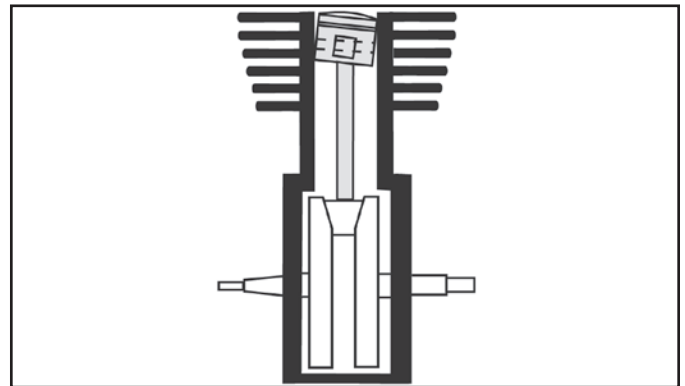

Figure 6

Visual Procedure

- A. Install pistons on rods without rings or wristpin clips. Bolt cylinders with gaskets in place.
- B. Move piston tight towards camside of engine.
- C. Turn engine over in normal direction of travel 2 or 3 revolutions and observe piston during process.
- D. Move piston towards driveside of engine and repeat Step C. If inaccuracies are present due to machining variations in cases, cylinders or pistons, top land of piston deck will appear closer to cylinder wall at one point around circumference. This means that piston is cocked in cylinder bore and can be corrected by bending rod in opposite direction. **Figure 6, above right,** shows an exaggerated side view of this condition.
- E. Repeat Steps B to D for other cylinder.

13. Modify knuckleheads for S&S® Oil Return Conversion Kit (knuckleheads installed on 1948 and later cases)

NOTE: Stock knuckleheads return oil down pushrod tubes using breather crankcase vacuum in 1936–'47 cases. If knuckleheads are installed on 1948 and later cases, an alternative route must be made to return oil from heads. S&S Sidewinder® kits for knucklehead engines for 1948 and later cases include cylinders equipped with special fittings, hoses and clamps for routing head oil to 1948 and later cylinder return passageways.

Procedure for this modification is as follows:

- A. Thoroughly clean valve spring cover cups which fit between guide and head. Be sure oil lines are completely clear as these often become partially or totally blocked.
- B. Mock up engine placing heads on cylinders with valve cover oil return line assemblies in place to observe how stock oil return lines from cups should be reshaped and bent to provide neat, unobstructed routing towards oil return fittings in Sidewinder cylinders.
- C. Carefully bend stock oil return lines and cut them off at appropriate distance so final hookup can be made using hose and clamps provided in kit. If old oil return lines are not useable, heat and remove from cups and braze in new tubing to provide proper hookup.

NOTE: Steel tubing must be free of sharp bends so oil will return from heads properly. Return hoses must not contact cylinder or head fins.



CAUTION

Restricted flow through oil return lines may cause unwarranted oil buildup in valve covers which may leak past valve guides causing engine to burn oil.



WARNING

Oil line must not contact any hot surfaces such as cylinders where it could melt and catch fire.

14. Piston to Valve Clearancing and Piston Installation (All)

NOTES:

- All valve spring spacing, rocker arm to collar, and rocker arm to rocker cover clearancing must be done before piston to valve clearancing can be checked.
- S&S pistons have sufficient valve clearance when used with most street high performance cams with lifts up to .525". However, we recommend that valve clearancing be checked if other than stock cam is used.

Piston to Valve Clearance

Check piston to valve clearance in following manner:

- A. Assemble engine with exception of cylinder heads.
- B. Turn engine over until piston in front cylinder is at top dead center. Paint area around valve pockets on pistons with machinist's blue.
- C. Place valves in cylinder head leaving off springs and retainers. Place head on cylinder and secure with one bolt.
- D. Lower valves until they contact piston. Rotate valve marking painted area.
- E. Remove head and check points of contact. Valve should fit in recessed area machined in piston dome.

NOTE: S&S recommends at least .060" clearance around periphery of valve.

- F. If insufficient clearance exists, remove piston and grind valve pocket until head of valve fits flush with proper clearance.
- G. Repeat procedure for other cylinder head.
- H. Spread layer of putty into valve pockets in both pistons.
- I. Assemble cylinder heads and bolt assemblies on cylinders with head gaskets in place. Install pushrods and adjust to simulate final assembly.
- J. Turn engine over in normal direction of travel two complete revolutions.
- K. Disassemble engine and check thickness of putty in valve pockets.

NOTE: S&S® recommends at least .060" clearance between valve and piston valve pocket recess. While .060" clearance is recommended minimum, it is advisable to have .080" and up, if possible.

 **CAUTION**

Insufficient clearance between piston and valves may cause them to contact each other during operation resulting in damage to piston and valve train components.

- L. If less than .060" clearance in any area exists, grind area until proper clearance is achieved.

Piston Installation

NOTES :

- All S&S Sidewinder Kits include forged pistons. These pistons do not have offset wristpins so they may be installed in either direction except for the rear piston. Rear pistons have a piston to piston clearance notch machined into the front piston skirt. The rear piston must be installed so the notch is toward the center of the engine.
- It is always important to know what piston type you have when ordering replacements or requesting information.
- See S&S Sidewinder piston information section on page 24

 **CAUTION**

Improper installation of pistons may cause unwarranted stress, premature wear and/or contact with each other or other engine components resulting in damage to them or other engine parts.

- A. Read piston instruction sheet for installation details.
- B. Piston with large cutout on one thrust face which provides piston to piston clearance is rear piston. Place cutout towards center of engine.

15. Final Assembly and Engine Installation

NOTE: *Cleaning parts prior to and during assembly and keeping parts clean after final assembly are imperative to minimize contaminants that may circulate in oil and shorten engine life. Many parts can be cleaned with soap and water first. Then, reclean all internal parts and gasket mating surfaces using high quality solvent that does not leave any harmful residues. Be sure to read and follow manufacturer's instruction label before use. Use drills and compressed air to clean all oil passageways of dirt, filings, etc. whenever possible. During actual final assembly, recoat all internal parts with high quality engine oil.*

 **CAUTION**

Manufacturing chips, dirt, and/or other contaminants circulating in engine oil may possibly damage engine components resulting in shorter engine life and possible engine failure.

 **WARNING**

- Some solvents, degreasers and other chemicals are harmful to skin, eyes and other body parts. Many items are flammable and present a fire hazard. Read manufacturer's instruction label for proper use. Use in well ventilated area and wear protective clothing when using them to avoid personal injury.
- Compressed air and particles dislodged by compressed air are harmful to eyes and body. Wear protective goggles when using compressed air and always direct air stream away from body parts such as hands and eyes and other people near you.

Head Gasket Surface Flatness Check

Before top end is assembled, head gasket to cylinder mating surfaces should be checked.



Incomplete contact between gasket surfaces of cylinders and cylinder heads may cause combustion leakage possibly resulting in damage to cylinders and/or other engine components.

Perform following steps for panhead and/or shovelhead

- A. Thoroughly clean head and cylinder gasket surfaces.
- B. Apply valve grinding compound to surface and lap head to cylinder.
- C. If brief lapping reveals that surfaces are not fully contacting each other, machine head gasket surface just enough to make complete contact.

NOTE: *If head gasket surface on cylinder head is machined, be sure that depth of recess equals height of fire ring, or head gasket may not seal. If more than .010" material is removed from head gasket surface, recheck piston to head and piston to valve clearances.*



Incorrect cylinder fire ring recess depth machined in cylinder heads may cause combustion leakage possibly resulting in damage to cylinders and/or other engine components.

- D. Thoroughly clean all lapping compound from heads and cylinders before assembling.



Lapping compound is highly abrasive and may damage engine components if allowed to circulate in engine oil.

Perform followings steps for knucklehead and Harley-Davidson® Evolution® engines:

- A. Thoroughly clean head and cylinder gasket surfaces.
- B. Place straight edge ruler across head gasket surface at different places around diameter to determine flatness.
- C. If unevenness is revealed, machine head gasket surface just enough to make complete contact.

Final Top End Assembly

NOTES:

- *We have good luck assembling base gaskets clean and dry. If you wish to use gasket cement we recommend using a "drying" type such as "Copper Coat" as "non-drying" type will occasionally allow gasket to squeeze out of position.*
- *We prefer to install head gaskets dry also. If you prefer, you can use a gasket sealer such as "Copper Coat."*

Knucklehead, panhead, and shovelhead Top End Assembly Procedure

NOTE: *We recommend installing cylinders without heads bolted to cylinders for two reasons.*

1. Combined weight of cylinder and cylinder head makes assembly cumbersome and hard to handle during installation.
2. Separate installation of cylinders and cylinder heads permits more leeway for adjustment to achieve a better manifold fit.



Installation of cylinders and cylinder heads as assemblies may result in damage to rings and piston assemblies. Improper intake manifold fit may cause intake air leaks/improper fuel mixture and resultant damage to engine components.



CAUTION

To avoid parts damage and obtain accurate torque readings, clean head bolt threads thoroughly before installation. For knucklehead, panhead, or shovelhead engines, head bolt threads and area of bolt head that contacts washer (if applicable) or cylinder must then be lubricated with Permatex® Anti-Seize Lubricant or similar anti-seize compound. S&S® has received reports of thread damage in these engines associated with use of engine oil to lubricate head bolts. Use of clean engine oil is preferable for headbolts in Harley-Davidson® Evolution® engines only.

- A. Thoroughly clean all top end parts. Blow dry with compressed air. Use high grade lacquer thinner on gasket surfaces.
- B. Insert head bolts with washers in place in cylinders and hold in place with rubber band.

NOTE: Certain head bolts will not go through cylinder flange after cylinder is bolted in place. Be sure chamfered sides of washers are located towards head side of bolts.



CAUTION

Incorrect placement of chamfered side of S&S head bolt washers may cause washer to crack and break resulting in head bolts coming loose.

- C. Position base gaskets on cases.
- D. Install pistons and rings per piston instructions.
- E. Coat piston skirts with engine oil and install cylinders onto pistons so crankcase studs protrude through cylinder base holes 1/8".
- F. Put Loctite® on threads of special base nuts provided.

NOTE: All four nuts must be worked on simultaneously since there is very little clearance between nuts and cylinders nuts have been designed so that cylinder wall behind nut is as thick as possible. (Even with 3⁵/₈" bore, wall behind nut is 25% heavier than stock cylinders). Do not tighten nuts.

- G. Remove rubberbands and install head gaskets and cylinder heads. Some head bolts will fall out. Make sure washers are on correctly if they fall off bolts.
- H. Shift heads and cylinders to properly align intake manifold.
- I. Final tighten base nuts to at least factory torque specs.
- J. Final tighten head bolts to at least factory torque specs. Tighten knucklehead bolts using allen wrench and short piece of pipe.
- K. Check head bolts and base nuts after engine has been run and retighten if necessary.

NOTES:

- Oil supply lines to heads must be fabricated. Design will depend on cases used.
- Oil pumps from 1968 and later produce higher oil pressure and greater volume than original knucklehead oil pumps. Additional oil to knuckleheads may be difficult to return. If so, restrict oil to heads by soldering oil supply tubing fitting in cases shut and meter by redrilling with smaller hole. We recommend no smaller than .0625" (1/16"). Our 98", 4³/₄" stroke test engine had a 1977 lower end and was assembled exactly by our instructions. Oil pump generated 30 lbs. pressure and return system worked flawlessly without metering.



CAUTION

Low or no oil flow to cylinder heads may damage rocker arms and/or other valve train components.

1984-'99 Model Top End Assembly Procedure

- A. Thoroughly clean all top end parts and blow dry with compressed air. Use high grade lacquer thinner on gasket surfaces.
- B. Install base gaskets dry. Be sure gaskets match cylinder base line up dowels and oil return passageways.
- C. Install pistons and rings per piston instructions.

NOTES

- Most 1984–'99 model Sidewinder® engines are designed with .055" piston to head clearance, squish, which is provided by thickness of head gasket. Therefore, in most cases pistons at top center should be flush with head gasket surface of cylinders. If pistons are higher than cylinders at top dead center, then something is wrong and S&S® should be notified.
- If additional compression is desired for racing purposes, a minimum of .040" squish can be run. Fifteen thousandths, .015", less clearance removes about 2.5ccs from stock combustion chamber volume. This adds about .25 to compression ratio. It is not recommended to run this amount of clearance unless engine is checked periodically since contact with head due to carbon buildup and wear may result after a period of time.

 **CAUTION**

Insufficient clearance between piston domes and cylinder heads will damage pistons, heads and/or other engine components.

- D. Coat piston skirts with engine oil and install cylinders.
- E. Install head gaskets dry. If included, place o-ring seals on line up dowel oil return tubes and be sure head gaskets are properly positioned.
- F. Before installing heads spin each headbolt down on it's respective stud to be sure threads are clean and free of contamination. Place a drop or two of oil on threads of each head bolt just prior to final assembly.

NOTE: Light coating of oil on head bolt threads minimizes friction so torque values will not be distorted. It cannot be emphasized enough to do these steps carefully. Maintaining a good head gasket seal depends on it.

 **CAUTION**

Improper torquing sequence and head bolt torque values may cause head gasket failure.

- G. Bolt heads on cylinders. Tighten bolts in stages using crossing pattern. **See Figure 7.** If using stock crankcases, follow the same bolt tightening sequence, but use stock three stage procedure and torque values shown. If using other aftermarket crankcases, contact the manufacturer for recommended head bolt torque specifications.

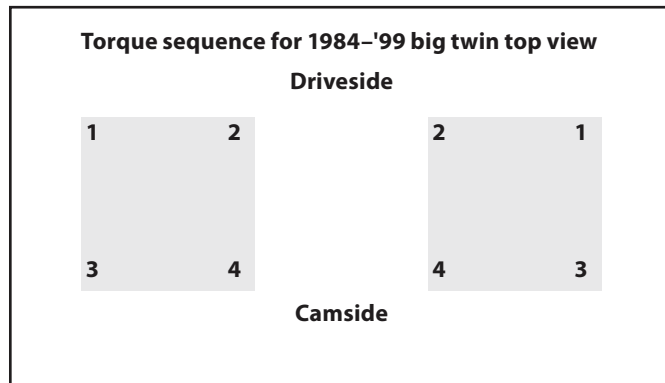

Figure 7

	S&S® Crankcases	Stock Crankcases
Stage 1	8 ft-lbs.	7-9 ft-lbs.
Stage 2	18 ft-lbs.	12-14 ft-lbs.
Stage 3	Turn additional 90° or ¼ turn	Turn additional 90°

IMPORTANT NOTE: Proper first time engine start-up and break-in for first 15 minutes is critical to achieve permanent and lasting head gasket seal. Follow "Engine Break-In" procedures at end of section 16.

 **CAUTION**

Improper first time engine start-up and break-in procedure may cause head gasket failure.

- H. Finish assembling top end per factory procedure. Install pushrods and adjust using instructions provided.

Final Assembly

- A. Install manifold.
- B. Install engine in frame.
- C. Install engine head mount.

NOTE: Stock head mount will be short if you are installing S&S Sidewinder Kit with cylinders .0625" (1/16") or more longer than stock. If cylinders that are 1/16" or less taller than stock are used, modify stock mount. If cylinders taller than 1/16" are used, install S&S head mount, part #93-4054. This mount is heavy duty and designed especially to provide support for tall, big inch engines. Its two piece design permits precise head to frame alignment which reduces stress and potential head mount failure.



CAUTION

Improper mounting of engine in frame may cause engine to come loose resulting in damage and/or failure of engine motor mounts and/or other engine mounting brackets.

16. Timing, Carburetion, Exhaust, Gearing & Break-in (All)

IGNITION TIMING NOTES:

- See Step 8, "Lower End Assembly," for explanation of S&S timing marks.
- S&S flywheels have timing marks that position pistons at 35° before top center, same as stock, when mark is in center of timing hole. Placing mark to right side of hole or just entering hole advances timing almost 5°. Vice versa, if mark is just leaving hole, timing is retarded almost 5°.
- Maximum performance in early engines traditionally has been with timing set at 37° to 39°, but because of poor gasoline, detonation, etc. it is advisable to stay with 35°. Some builders will even retard ignition timing slightly because of aforementioned problems, but if you do, watch heat build-up. If there is any doubt, stay with factory recommended settings.
- Sidewinder® kits for Harley-Davidson® Evolution® engines—tests conducted on our dyno have indicated that the best horsepower will be produced with timing set from 30° to 35°, depending on cylinder head design, compression ratio and type of fuel. S&S recommends that an aftermarket electronic ignition with variable advance curves be used to allow adequate flexibility in tuning.
- Whatever ignition system is used, the best rule of thumb for most situations is to follow stock timing specs and watch for signs of detonation and/or excessive heat.
- Ignition timing for engines with dual plugged heads should generally be retarded 5–8° from the stock setting. However, due to the large number of factors involved, optimum ignition timing is impossible to accurately predict and must be determined for each engine by experimentation.



CAUTION

Improper ignition timing may cause excessive engine heat which may damage pistons and/or other engine components.

CARBURETION NOTES:

- All S&S® test engines have been run with S&S carburetors. A Super E or Super G carburetor is recommended for most strokers. Consult carburetor jetting instructions for specific jetting recommendations.
- If another type carburetor is used, it must be made to run rich enough so engine is not damaged. Other carburetor types are a personal problem and we cannot answer questions concerning them. It is best to call carb manufacturer if you have any questions.

EXHAUST SYSTEMS NOTES:

- To establish performance guidelines, S&S used 30" long stock diameter drag pipes on pre-1984 engines with good results. We suggest you try them on these engines to establish a baseline to compare with other systems. Evolution engines are easier to carburate with muffled systems.
- You might ask the manufacturer of the exhaust system you are considering if he has had any experience with S&S strokers. Many systems are made for looks with little consideration given to performance. Most stock systems and many aftermarket ones tried are too restrictive for good performance. S&S offers slip-ons that work well with stock head pipes. These work very well in most situations and offer an inexpensive alternative to a new exhaust system. Evolution engines should use a system equipped with a crossover pipe that connects front and rear header pipes.

GEARING NOTES:

- Gearing depends on total weight of machine and rider(s), size of engine, caming, exhaust system and type of riding to be done. Most Sidewinders are capable of pulling more gear. We suggest you break engine in with stock gearing to minimize lugging engine. After engine is broken in you will have a better feel of its potential and can change gearing accordingly.
- For those who wish to determine their final drive gear ratio the formula is as follows:

$$\text{Engine Revolutions per one Revolution of Rear Wheel} = \frac{(\text{Clutch Sprocket}^*) \times (\text{Rear Wheel Sprocket}^*)}{(\text{Motor Sprocket}^*) \times (\text{Transmission Sprocket}^*)}$$

*Number of teeth on each sprocket

Break-In Procedure

NOTE: These engines must be broken in. They will feel extremely strong so resist the impulse to turn it on. Break it in properly.



CAUTION

Lugging or running engine prematurely at high rpms may result in damage to pistons and/or other engine components. S&S voids its guarantee if engine is not broken in properly.

Break engine in using following procedure:

- A. On initial engine startup, don't just sit and idle motor while you admire your work, or tinker with minor adjustments. Heat buildup can be excessive. Do not let engine overheat.

IMPORTANT NOTE: EVOLUTION® ENGINES:

Proper first time engine start-up and break-in for first 15 minutes is critical to achieve permanent and lasting head gasket seal. Upon initial start-up, idle engine at 1000–1500 rpm until cylinder head temperature reaches about 250°. Do not crack throttle or put any load on engine during this time. Heat buildup is necessary to cause heads and cylinders to expand and seal. Do not let heat get excessive.



CAUTION

Improper initial engine start-up may cause head gaskets to fail prematurely.

- B. First 50 miles are most critical for new rings and piston break-in. Most engine damage will initially occur during this period. Keep heat down by not exceeding 2500 rpm. Vary speed. Do not lug engine.
- C. Next 500 miles should be spent running engine no faster than 3500 rpm or about 50-55 mph. Do not lug engine and continue to vary speed.
- D. For balance of first 1000 miles, speed can be run up to 60 to 70. Continue to run engine at all different speeds including lower 40-45 mph ranges.
- E. 1000 to 2000 miles—basically same procedures as before. You can be a little more liberal with rpm range. Avoid overheating engine and putting any hard strain on it (drag racing, trailer towing, sidecar operation).
- F. 2000 miles and up—have fun!

Part Number	Description	Part # Stamped on Piston	Close Fit	Loose Fit	Old S&S® PNs That Are Superseded					
106-5535	Piston Set 3 $\frac{3}{8}$ " Standard, HC, .791" WP, 1936-'84 bt	106-5531	.0035" to .004"	.0045" to .0055"	92-1800	92-1830	92-1840	92-1620	92-1630	92-1640
106-5536	Piston Set 3 $\frac{3}{8}$ " +.010", HC, .791" WP, 1936-'84 bt	106-5532	.0035" to .004"	.0045" to .0055"	92-1801	92-1831	92-1841	92-1621	92-1631	92-1641
106-5537	Piston Set 3 $\frac{3}{8}$ " +.020", HC, .791" WP, 1936-'84 bt	106-5533	.0035" to .004"	.0045" to .0055"	92-1802	92-1832	92-1842	92-1622	92-1632	92-1642
106-5538	Piston Set 3 $\frac{3}{8}$ " +.030", HC, .791" WP, 1936-'84 bt	106-5534	.0035" to .004"	.0045" to .0055"	92-1803	92-1833	92-1843	92-1623	92-1633	92-1643
106-5789	Piston Set 3 $\frac{3}{8}$ " +.060", HC, .791" WP, 1936-'84 bt	106-5790	.0035" to .004"	.0045" to .0055"	92-1806	92-1836	92-1846	92-1626	92-1636	92-1646
92-1900 Series	Piston Set 3 $\frac{3}{8}$ " flat top .792" WP, 1984-'99 bt	92-1900 to 92-1906	.002" to .0025"	.003" to .004"	-	-	-	-	-	-
92-1930 Series	Piston Set 3 $\frac{3}{8}$ " flat top .792" WP, 1984-'99 bt	92-1930 to 92-1936	.002" to .0025"	.003" to .004"	-	-	-	-	-	-
92-1940 Series	Piston Set 3 $\frac{3}{8}$ " flat top .792" WP, 1984-'99 bt and 1986-'03 xl	92-1940 to 92-1946	.002" to .0025"	.003" to .004"	-	-	-	-	-	-

S&S Sidewinder Piston Information



CAUTION

Failure to follow instructions and perform required clearancing, installation and/or break-in procedures correctly may result in damage to pistons and/or other engine components. S&S® voids its guarantee if pistons are not installed and/or broken in properly.

1. For maximum piston and ring life, fit pistons using appropriate close fit dimensions. Close fit requires absolute adherence to new engine break-in as outlined.
2. For immediate drag strip use, fit pistons using loose fit dimensions. Attempt to break in rings and pistons with 50 easy miles if possible. Piston and ring life will be reduced when using loose fit dimensions.
3. Measure all pistons across thrust faces 90° to wristpin holes. Make a series of measurements starting directly below oil ring groove and ending at extreme bottom of skirt. Use widest measurement to represent size of piston. Some pistons will measure widest at extreme bottom of skirt. Others will measure widest somewhere between oil ring groove and extreme bottom of skirt. If piston is notched for placement in rear cylinder, use measurement directly above notch as extreme bottom of skirt measurement.
4. S&S recommends the use of #220–#280 grit stone for final honing of cylinders for all Sidewinder® big bore engines.
5. Follow procedure recommended in Harley-Davidson® service manual for boring and honing cylinders. S&S Cylinder Torque Plate Kit, S&S Part #53-0016, or Harley-Davidson® torque plates, H-D® Part #33446, are required when fitting cylinders for Evolution® engines to simulate engine operating conditions. Cylinders may distort more than .001" if torque plates are not used.

All reference to Harley-Davidson® part numbers is for identification purposes only. We in no way are implying that any of S&S® Cycle's products are original equipment parts or that they are equivalent to the corresponding Harley-Davidson® part number shown.

Piston Installation

1. All currently supplied pistons are forged and do not have offset wristpins. They have no special features and can be installed any way the builder desires except for the rear piston which has a piston to piston clearance notch on front skirt thrust face of the piston. Install rear piston with notch toward front piston.
2. Check all installations for a minimum of .060" clearance between pistons at bottom of stroke.
3. Check all installations for a minimum of .060" clearance between pistons and flywheels at bottom of stroke. New 4 $\frac{5}{8}$ " Sidewinder installations should come with proper piston to flywheel clearance. Replacement pistons may or may not come with adequate clearance. Compare replacement pistons with ones being replaced and make corrections accordingly.

Wristpin Retainer Installation

1. All pistons use round wire wristpin retainers. Make sure retainer groove is free of burrs and foreign material.
2. Round wire style clips which are identical to and interchangeable with stock clips for Harley-Davidson® Evolution® engines require a specially chamfered end wristpin. Install clips using factory recommended procedure. Special indexing of clip is not necessary. Be sure clip is fully seated in groove.

Ring Installation

1. Piston ring widths have changed on some piston series from time to time. It is recommended that ring parts supplied with pistons be recorded for future reference in the event replacement rings are required.
2. Oil rings are three piece circumferential expander cylinder type. End gap on all rails is .010" to .040". Grind end gaps as necessary. Do not leave burrs as they will scratch cylinder walls. Do not shorten expander for any reason. Place end gaps as follows: Expander—gap in center of thrust face 90° to wristpin. Bottom rail—gap 2" to right of expander gap. Top rail—gap 2" to left of expander gap.
3. Compression rings may be cast iron type, chrome faced cast iron type, moly faced cast type and chrome type. The most common combinations supplied are two chrome faced cast, one chrome faced cast and one cast iron, and one moly faced cast and one cast iron. Chrome faced or moly faced ring always goes in top groove. Cast iron type usually goes in second groove. Cast iron type is usually a reverse torsion style ring distinguished by an inside diameter bevel on one side of ring with a "dot" or oversize mark on other side of ring. If two cast iron compression rings are supplied in set, check to see if one is reverse torsion style ring. Reverse torsion style ring always goes in second groove. The following rules apply to compression ring identification and placement. Rules are listed in order of priority.
 - a. Chrome or moly ring goes in top groove.
 - b. Cast iron regular or reverse torsion goes in second groove.
 - c. Any identifying "pip" marks, dots or oversize marks go to top of piston.
 - d. One dot goes in top groove, two dots go in second groove.
 - e. If both have one dot or two dots, they can go in either groove.
 - f. If ring has dots and inside diameter bevel, dots go to top of piston.
 - g. If ring has no dots and inside diameter bevel, bevel goes to top of piston.
 - h. If ring has no dots, etc. and no bevel, it can go either way.

NOTE: End gap on all compression rings is .012" to .030". In certain instances, the next oversize ringset may be supplied with pistons, ie. + .060" oversize rings with +.050" pistons. This is permissible but end gaps must be filed. Place end gaps on all compression rings as follows: Second groove—3" to right of oil expander gap. Top groove—gap 3" to left of oil expander gap.

4. When rings are compressed for piston installation in bore, be sure oil ring expander ends do not overlap and ring stays assembled properly.

Break-In Procedure

This procedure applies to all close fit pistons.



CAUTION

Lugging engine at low rpms and/or running engine prematurely at high rpms may result in damage to pistons and/or other engine components. S&S® voids its guarantee if engine is not broken in properly.

1. On initial engine startup, don't just sit and idle motor while you admire your work, or tinker with minor adjustments. Heat buildup can be excessive. Do not let engine overheat.

IMPORTANT NOTE: EVOLUTION® ENGINES

Proper first time engine start-up and break-in for first 15 minutes is critical to achieve permanent and lasting head gasket seal. Upon initial start-up, idle engine at 1000–1500 rpm until cylinder head temperature reaches about 250°. Do not crack throttle or put any load on engine during this time. Heat buildup is necessary to cause heads and cylinders to expand and seal. Do not let heat get excessive. Prior to initial start-up, a .003"-.005" "feeler gauge" will fit between head gasket and head and cylinder gasket surfaces stopping at fire ring on head gasket. Warming engine as instructed will tightly close this gap producing a good, lasting seal.

2. First 50 miles are most critical for new rings and piston break-in. Most engine damage will initially occur during this period. Keep heat down by not exceeding 2500 rpm. Vary speed. Do not lug engine.
3. Next 500 miles should be spent running engine no faster than 3500 rpm or about 50–55 mph. Do not lug engine and continue to vary speed.
4. For balance of first 1000 miles, speed can be run up to 60–70. Continue to run engine at all different speeds including lower 40–45 mph ranges. Do not lug engine.
5. 1000–2000 miles basically same as before but a little more liberal with rpm range. Avoid overheating and lugging engine—no drag racing, trailer towing, etc.
6. 2000 miles and up—have fun!

S&S® big twin connecting rod information

S&S connecting rods are stronger than stock and most other types of rods because:

1. They have wider I-beams, heavier radiuses in critical areas and extra gusseting (Supremes only).
2. They are forged from 4140 chrome moly steel.
3. They are heat treated to harder specifications.
4. They are shot peened.

IMPORTANT NOTES

- Whenever clearancing is performed during any installation checks, follow recommended procedures only. Remove material only from specified areas.
- Thoroughly inspect, debur and clean all parts before final assembly. Blow air through oil passageways to check for blockages.
- Read manufacturer's instruction label before using solvents when cleaning and assembling parts.
- Any modification performed to S&S® rods other than those specified in these instructions voids any and all S&S warranties.



CAUTION

Failure to follow recommended clearancing procedures and to use recommended clearances may cause damage to rods and/or other engine components.



WARNING

- **Unwarranted connecting rod clearancing may weaken a connecting rod possibly causing it to break. A broken connecting rod may cause the engine to stop suddenly without warning during operation possibly causing loss of control of motorcycle and personal injury to you or others.**
- **Some solvents, degreasers and other chemicals are harmful to skin, eyes and other body parts. Many items are flammable and present a fire hazard. Read manufacturer's instruction label for proper use. Use in well ventilated area and wear protective clothing when using them to avoid personal injury.**
- **Compressed air are harmful to eyes and body. Wear protective goggles when using compressed air and always direct air stream away from body parts such as hands and eyes and other people near you.**

Flywheel Balance

All S&S rods, because of their beefier construction, weigh more than comparable stock types. Therefore, it is recommended to check and rebalance the flywheels when replacing other rods with S&S types.

Flywheel and Crankcase Clearancing

Increased front to rear I-beam width and crankpin end bulk and gusseting means additional rod to flywheel and rod to crankcase clearancing. Prior to final assembly and flywheel rebalancing each flywheel must be mocked up with mainshaft and rods to be used to check clearances. Places to note for contact are:

1. Female rod crankpin end to mainshaft nut—.030" minimum clearance recommended.
2. Female rod crankpin end to inner flywheel rim—.060" clearance recommended.
3. Wristpin end to flywheel edge on both female and male rods—.060" clearance recommended. With the camside flywheel and rods mocked up, install the assembly in the right crankcase half with pistons (less rings) and cylinders in place. Check for rod to crankcase and cylinder spigot contact on both the front and rear of each cylinder. Sixty thousandths, .060", minimum is also recommended in all of these areas.

NOTE: Whenever clearancing is performed during any of these checks, do not remove any material from the connecting rods as clearancing on the rods may unnecessarily weaken them. Make adjustments to the point of contact on the mainshaft nut, flywheel rim, crankcase, cylinder spigot, etc..

Specifications and Recommendations

- Centerline measurement—Rod sets #34-7004, #34-7011, #34-7206, and #34-7212, #34-7214 measure 7.440" from wristpin centerline to crankpin centerline. This measurement equals stock Big Twin rods from 1974-'99 and is .030 less than stock, 1936-'73 big twin rods. S&S big twin rods can be used in applications replacing earlier, long stock rods with the most noticeable effect being a drop in compression of about $\frac{1}{3}$ to $\frac{1}{2}$ a point piston to piston and piston to flywheel clearances should be checked. Rod to rod clearance—S&S rods have been machined to fit stroker flywheels up to and including 5" stroke without additional rod to rod clearance. If a longer stroke is to be used, this clearance must be checked and increased as necessary—.060" clearance is recommended and must be removed from the point of contact on the female rod. Only remove enough material to obtain recommended clearance. Smooth blend all clearance contours.
- Roller bearing clearance—S&S rods have been honed for street applications and require a new engine break-in over a period of 2000 miles minimum.

NOTE: *If they are to be used in a drag machine or other racing application where proper engine break-in is not possible, additional roller bearing clearance of .0005" minimum must be honed into the rod bearing races.*

- Polishing - All S&S rods are shot peened to increase fatigue resistance. Grinding and polishing the surfaces reduces this effect and is not recommended.

NOTE: *S&S voids its guarantee if any S&S rods are ground, polished, or modified in any way.*

- Rod side play—Recommended rod side play is .015" to .035". If additional side play is required, grind equal amounts off the thrust faces on both sides of the female rod. Recommended bearing cage width is .008" to .020" less than the female rod width.

NOTE: *When this combination is used in some early S&S® flywheels, additional crankpin nut socket to flywheel clearance may be required. In these instances, S&S recommends removing the required material from the flywheels.*

- Torque specifications—Use green grade Loctite® on the threads during assembly. Tighten crankpin nuts to stock Harley-Davidson® factory specifications in stock cast iron flywheels. When using S&S forged flywheels, tighten crankpin nuts to 400 ft-lbs. minimum.
- Preassembly cleaning—Disassemble and thoroughly clean all parts in lacquer thinner to remove dirt, filings, etc. Pay particular attention to the crankpin oil passageways. Reassemble using high quality break-in grease.



Instruction 51-1016

04-08-13

Copyright © 2002, 2006, 2013
by S&S® Cycle, Inc.

All rights reserved.
Printed in the U.S.A.

S&S® Cycle, Inc.

14025 Cty Hwy G PO Box 215

Viola, Wisconsin 54664

Phone: 608-627-1497 • Fax: 608-627-1488
Technical Service Phone: 608-627-TECH (8324)
Technical Service Email: sstech@sscycycle.com
Website: www.sscycycle.com



Installation Instructions: S&S® Non-Copper Head Gaskets for Harley-Davidson® Evolution® & Twin Cam 88® Engines

NOTE: *Cleaning parts prior to and during assembly and keeping parts clean after final assembly are imperative to minimize contaminants that may circulate in oil and shorten engine life. Many parts can be cleaned with soap and water first. Then, reclean all internal parts and gasket mating surfaces using high quality solvent that does not leave any harmful residues. Be sure to read and follow manufacturer's instruction label before use. Use brushes and compressed air to clean all oil passageways of dirt, filings, etc. whenever possible. During final assembly, recoat all internal parts with clean motor oil.*

CAUTION

Installer is responsible for ensuring parts are clean at assembly. Damage caused by manufacturing chips, dirt and/or other contaminants is not covered under warranty.

WARNING

- **Some solvents, degreasers and other chemicals are harmful. Many items are flammable and present a fire hazard. Read the manufacturer's instruction label for proper use. Use in well ventilated area and wear protective clothing to avoid injury.**
- **Compressed air and particles dislodged by compressed air are harmful to eyes and body. Wear protective goggles when using compressed air and always direct air stream away from body parts such as hands and eyes. Never direct compressed air toward other people.**

Top End Assembly Procedure

- A. Thoroughly clean all top end parts and blow dry with compressed air. Use high grade lacquer thinner on gasket surfaces.
- B. Install base gaskets dry. Be sure gaskets match cylinder base line up dowels and oil return passageways.
- C. Install pistons and rings per instructions, or S&S® piston instruction sheet 51-1028.
- D. Coat piston skirts with engine oil and install cylinders.
- E. Install head gaskets dry with widest side of metal fire ring against cylinder.

NOTE: *S&S 3¾" bore head gaskets for 1999-up big twins require o-rings around the cylinder head locating dowels similar to stock head gaskets. S&S 3⅞", 4" and 4⅛" bore head gaskets do not use o-rings around cylinder head locating dowels.*

NOTE: *All S&S cylinder head kits are supplied with .045" thick head gaskets. This clearance promotes better combustion chamber turbulence and flame travel.*

CAUTION

Insufficient clearance between piston domes and cylinder heads or piston domes and valves will cause damage to pistons, heads and/or valves.

- F. Before installing heads, check the threads of cylinder studs and head bolts by spinning each head bolt down on its respective stud to be sure threads are clean and undamaged. If binding is encountered, correct before proceeding. Place a drop or two of oil on threads of each head bolt just prior to final assembly.

NOTE: Light coating of oil on head bolt threads minimizes friction so torque values will not be distorted. It cannot be emphasized enough how important it is to do these steps carefully. Maintaining a good head gasket seal depends on it.

G. Bolt heads on cylinders using stock washers and head bolts or S&S® washers and head bolts when provided. Tighten head bolts in stages using crossing pattern shown below. Use torque specifications appropriate for crankcase type. Do not exceed specified torque values.

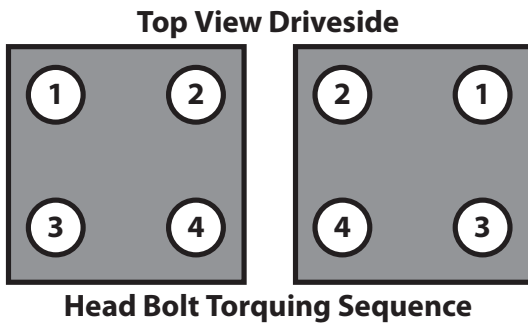

	S&S® Case	Stock Case
Stage 1	8 ft-lbs	7-9 ft-lbs
Stage 2	18 ft-lbs	12-14 ft-lbs
Stage 3	Turn 90° more	Turn 90° more

NOTE: Stock head bolt torque specifications must be used with stock crankcases. Stronger material used in S&S crankcases allow the use of higher torque values.

CAUTION

Improper torquing sequence and head bolt torque values may cause head gasket failure. Exceeding specified torque values may cause cylinder studs to pull out of crankcases, resulting in damage to crankcases and loss of head gasket seal.

H. Finish assembling top end per OEM instructions. Install and adjust pushrods per factory specifications, or manufacturers pushrod instructions.

Initial Start Up

- A. Run engine approximately one minute at 1250-1750 rpm. DO NOT crack throttle or subject engine to any loads as head gaskets are susceptible to failure at this time. During this time check to see that oil pressure is normal, that oil is returning to the oil tank, and that no leaks exist.
- B. Shut off engine and thoroughly check for any leaks or other problems. Let engine cool to the touch
- C. After engine has cooled, start up again and allow the motor to build some heat. Engine should be run no longer than three to four minutes. When the cylinders become warm/hot to the touch (approximately 150°) shut the motor down and let it cool to room temp. Follow the same cautions as for the initial start-up, and continue to watch for problems.
- D. Repeat this procedure 3 or 4 times. With a new engine, each successive time should take slightly longer to warm up and you can increase the temp slightly each time (+10°). You can be more liberal each time with the rpm, gently vary rpm continuously from idle up to 2500 rpm in the final cycle. Do not allow engine temperature to become excessive. After the motor has cooled to room temperature for the final time the motorcycle can be ridden normally.
- E. If the engine is new or newly rebuilt, adhere to the break-in procedure specified by the manufacturer of the components installed.

CAUTION

- **Improper first time engine start-up and break-in procedure may cause head gasket failure.**
- **Do not allow engine temperature to become excessive as permanent engine damage may result.**

Instruction 51-1169
4-12-06

Copyright © 2003, 2005, 2006
by S&S Cycle, Inc.

All rights reserved.
Printed in the U.S.A.

S&S® Cycle, Inc.

235 Causeway Blvd.
La Crosse, Wisconsin 54603
Phone: 608-627-1497 • Fax: 608-627-1488
Technical Service Phone: 608-627-TECH (8324)
Technical Service Email: sstech@sscycle.com
Website: www.sscycle.com



Because every industry has a leader

Installation Instructions: S&S® Stainless Steel Cylinder Base Nuts

S&S PN 93-3063 Fits Big Twin Engines 1930-'84

DISCLAIMER:

S&S parts are designed for high performance, off road, racing applications and are intended for the very experienced rider only. The installation of S&S parts may void or adversely affect your factory warranty. In addition such installation and use may violate certain federal, state, and local laws, rules and ordinances as well as other laws when used on motor vehicles used on public highways, especially in states where pollution laws may apply. Always check federal, state, and local laws before modifying your motorcycle. It is the sole and exclusive responsibility of the user to determine the suitability of the product for his or her use, and the user shall assume all legal, personal injury risk and liability and all other obligations, duties, and risks associated therewith.

The words Harley®, Harley-Davidson®, H-D®, Sportster®, Evolution®, and all H-D part numbers and model designations are used in reference only. S&S Cycle is not associated with Harley-Davidson, Inc.

SAFE INSTALLATION AND OPERATION RULES:

Before installing your new S&S part it is your responsibility to read and follow the installation and maintenance procedures in these instructions and follow the basic rules below for your personal safety.

- Gasoline is extremely flammable and explosive under certain conditions and toxic when inhaled. Do not smoke. Perform installation in a well ventilated area away from open flames or sparks.
- If motorcycle has been running, wait until engine and exhaust pipes have cooled down to avoid getting burned before performing any installation steps.
- Before performing any installation steps disconnect battery to eliminate potential sparks and inadvertent engagement of starter while working on electrical components.
- Read instructions thoroughly and carefully so all procedures are completely understood before performing any installation steps. Contact S&S with any questions you may have if any steps are unclear or any abnormalities occur during installation or operation of motorcycle with a S&S part on it.
- Consult an appropriate service manual for your motorcycle for correct disassembly and reassembly procedures for any parts that need to be removed to facilitate installation.
- Use good judgement when performing installation and operating motorcycle. Good judgement begins with a clear head. Don't let alcohol, drugs or fatigue impair your judgement. Start installation when you are fresh.
- Be sure all federal, state and local laws are obeyed with the installation.
- For optimum performance and safety and to minimize potential damage to carb or other components, use all mounting hardware that is provided and follow all installation instructions.
- Motorcycle exhaust fumes are toxic and poisonous and must not be inhaled. Run motorcycle in a well ventilated area where fumes can dissipate.

IMPORTANT NOTICE:

Statements in this instruction sheet preceded by the following words are of special significance.



WARNING

Means there is the possibility of injury to yourself or others.

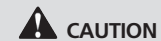

CAUTION

Means there is the possibility of damage to the part or motorcycle.

NOTE

Other information of particular importance has been placed in italic type.

S&S recommends you take special notice of these items.

WARRANTY:

All S&S parts are guaranteed to the original purchaser to be free of manufacturing defects in materials and workmanship for a period of twelve (12) months from the date of purchase. Merchandise that fails to conform to these conditions will be repaired or replaced at S&S's option if the parts are returned to us by the purchaser within the 12 month warranty period or within 10 days thereafter.

In the event warranty service is required, the original purchaser must call or write S&S immediately with the problem. Some problems can be rectified by a telephone call and need no further course of action.

A part that is suspect of being defective must not be replaced by a Dealer without prior authorization from S&S. If it is deemed necessary for S&S to make an evaluation to determine whether the part was defective, a return authorization number must be obtained from S&S. The parts must be packaged properly so as to not cause further damage and be returned prepaid to S&S with a copy of the original invoice of purchase and a detailed letter outlining the nature of the problem, how the part was used and the circumstances at the time of failure. If after an evaluation has been made by S&S and the part was found to be defective, repair, replacement or refund will be granted.

ADDITIONAL WARRANTY PROVISIONS:

- (1) S&S shall have no obligation in the event an S&S part is modified by any other person or organization.
- (2) S&S shall have no obligation if an S&S part becomes defective in whole or in part as a result of improper installation, improper maintenance, improper use, abnormal operation, or any other misuse or mistreatment of the S&S part.
- (3) S&S shall not be liable for any consequential or incidental damages resulting from the failure of an S&S part, the breach of any warranties, the failure to deliver, delay in delivery, delivery in non-conforming condition, or for any other breach of contract or duty between S&S and a customer.
- (4) S&S parts are designed exclusively for use in Harley-Davidson® and other American v-twin motorcycles. S&S shall have no warranty or liability obligation if an S&S part is used in any other application.

S&S® stainless steel cylinder base nuts PN 93-3063 are a special design that simplifies the assembly and service of S&S SH-Series 3 $\frac{5}{8}$ " bore engines. They may be used on any big twin engine using $\frac{7}{16}$ " cylinder studs, providing that the stud protrusion above the base flange falls within the range specified. See Drawing Below.

When S&S base nuts 93-3063 are used with S&S studs 31-2328, and S&S cylinders for shovelhead engines (with .725" thick base flanges - produced after Jan 2004). The cylinder can be lowered over the studs and onto the case before installing the nuts.

NOTE: In some cases, it may be necessary to slightly raise the cylinder to start the nuts onto the studs.

S&S base nuts now accept a $\frac{7}{16}$ " box end wrench (previous design S&S base nuts required a $\frac{1}{2}$ " open end wrench).

If studs protrude more than the max. dimension given in the drawing, the base nuts will bottom out on the stud before tightening down on the cylinder base flange. The studs will need to be shortened before installing the the nuts.

⚠ CAUTION

If shortening the studs with the crankcase assembly still mounted in the frame, be extremely careful not to contaminate the inside of the case.

If studs protrude less than the minimum dimension given in the drawing, there will not be enough thread engagement into the nuts. The studs will need to be replaced before installing the nuts. Install replacement studs using high strength Loctite® 609 (green).

⚠ CAUTION

Re-positioning existing studs to obtain the dimension given in the drawing is not recommended.

After verifying correct stud protrusion, assemble cylinders to crankcase. Apply a drop of medium strength Loctite® 242 (blue) to upper area of studs before installing nuts.

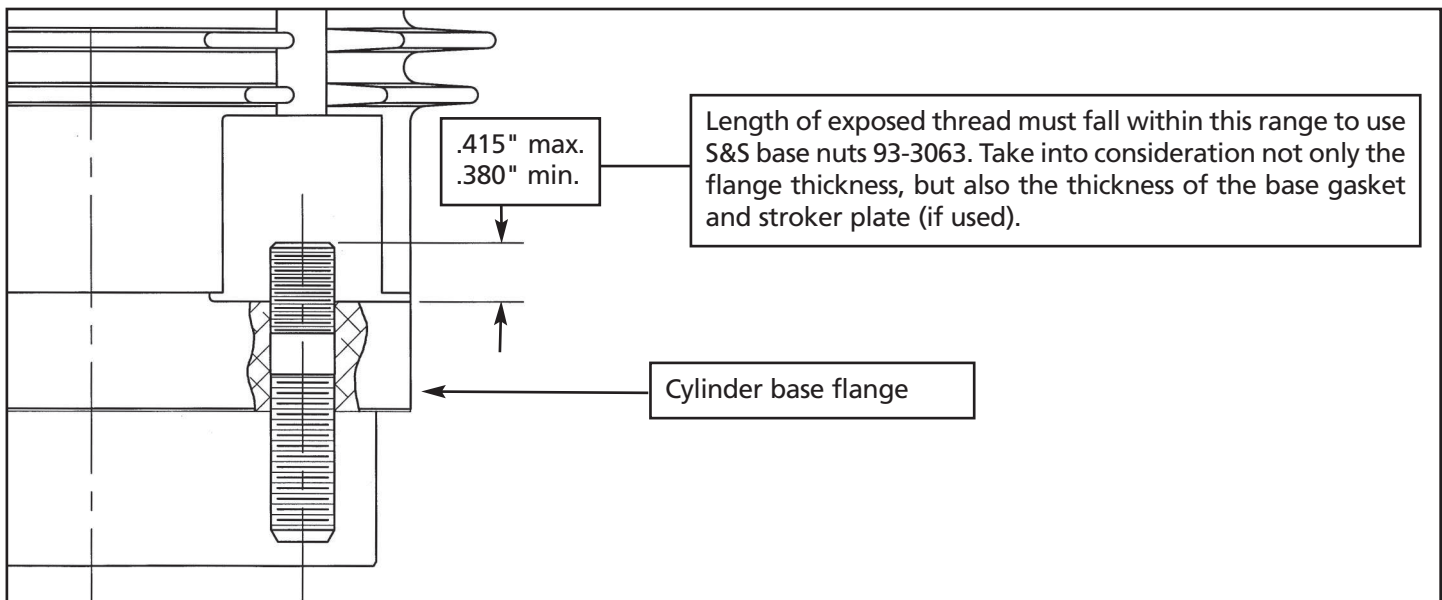

Because every industry has a leader

Instruction 106-6072
01-16-14

Copyright © 2009-2014
by S&S® Cycle, Inc.

All rights reserved.
Printed in the U.S.A.

S&S® Cycle, Inc.

14025 Cty Hwy G, PO Box 215
Viola, Wisconsin 54664
Phone: 608-627-1497 • Fax: 608-627-1488
Technical Service Phone: 608-627-TECH (8324)
Technical Service Email: sstech@sscycle.com
Website: www.sscycle.com



Installation Instructions for S&S® Forged Pistons For Stock Bore And 3⁵/₈" Bore Harley-Davidson® 1936-'99 Big Twin And 1957- Present Sportster® Models

DISCLAIMER:

S&S parts are designed for high performance, closed course, racing applications and are intended for the very experienced rider only. The installation of S&S parts may void or adversely affect your factory warranty. In addition such installation and use may violate certain federal, state, and local laws, rules and ordinances as well as other laws when used on motor vehicles used on public highways, especially in states where pollution laws may apply. Always check federal, state, and local laws before modifying your motorcycle. It is the sole and exclusive responsibility of the user to determine the suitability of the product for his or her use, and the user shall assume all legal, personal injury risk and liability and all other obligations, duties, and risks associated therewith.

The words Harley®, Harley-Davidson®, H-D®, Sportster®, Evolution®, and all H-D part numbers and model designations are used in reference only. S&S Cycle is not associated with Harley-Davidson, Inc.

SAFE INSTALLATION AND OPERATION RULES:

Before installing your new S&S part it is your responsibility to read and follow the installation and maintenance procedures in these instructions and follow the basic rules below for your personal safety.

- Gasoline is extremely flammable and explosive under certain conditions and toxic when breathed. Do not smoke. Perform installation in a well ventilated area away from open flames or sparks.
- If motorcycle has been running, wait until engine and exhaust pipes have cooled down to avoid getting burned before performing any installation steps.
- Before performing any installation steps disconnect battery to eliminate potential sparks and inadvertent engagement of starter while working on electrical components.
- Read instructions thoroughly and carefully so all procedures are completely understood before performing any installation steps. Contact S&S with any questions you may have if any steps are unclear or any abnormalities occur during installation or operation of motorcycle with a S&S part on it.
- Consult an appropriate service manual for your motorcycle for correct disassembly and reassembly procedures for any parts that need to be removed to facilitate installation.
- Use good judgment when performing installation and operating motorcycle. Good judgment begins with a clear head. Don't let alcohol, drugs or fatigue impair your judgment. Start installation when you are fresh.
- Be sure all federal, state and local laws are obeyed with the installation.
- For optimum performance and safety and to minimize potential damage to carb or other components, use all mounting hardware that is provided and follow all installation instructions.
- Motorcycle exhaust fumes are toxic and poisonous and must not be breathed. Run motorcycle in a well ventilated area where fumes can dissipate.

IMPORTANT NOTICE:

Statements in this instruction sheet preceded by the following words are of special significance.

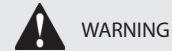

WARNING

Means there is the possibility of injury to yourself or others.



CAUTION

Means there is the possibility of damage to the part or motorcycle.

NOTE

Other information of particular importance has been placed in italic type.

S&S recommends you take special notice of these items.

WARRANTY:

All S&S parts are guaranteed to the original purchaser to be free of manufacturing defects in materials and workmanship for a period of twelve (12) months from the date of purchase. Merchandise that fails to conform to these conditions will be repaired or replaced at S&S's option if the parts are returned to us by the purchaser within the 12 month warranty period or within 10 days thereafter.

In the event warranty service is required, the original purchaser must call or write S&S immediately with the problem. Some problems can be rectified by a telephone call and need no further course of action.

A part that is suspect of being defective must not be replaced by a Dealer without prior authorization from S&S. If it is deemed necessary for S&S to make an evaluation to determine whether the part was defective, a return authorization number must be obtained from S&S. The parts must be packaged properly so as to not cause further damage and be returned prepaid to S&S with a copy of the original invoice of purchase and a detailed letter outlining the nature of the problem, how the part was used and the circumstances at the time of failure. If after an evaluation has been made by S&S and the part was found to be defective, repair, replacement or refund will be granted.

ADDITIONAL WARRANTY PROVISIONS:

- (1) S&S shall have no obligation in the event an S&S part is modified by any other person or organization.
- (2) S&S shall have no obligation if an S&S part becomes defective in whole or in part as a result of improper installation, improper maintenance, improper use, abnormal operation, or any other misuse or mistreatment of the S&S part.
- (3) S&S shall not be liable for any consequential or incidental damages resulting from the failure of an S&S part, the breach of any warranties, the failure to deliver, delay in delivery, delivery in non-conforming condition, or for any other breach of contract or duty between S&S and a customer.
- (4) S&S parts are designed exclusively for use in Harley-Davidson® and other American v-twin motorcycles. S&S shall have no warranty or liability obligation if an S&S part is used in any other application.

GENERAL INFORMATION

1. For maximum piston and ring life, fit pistons using close fit dimensions. Close fit requires absolute adherence to new engine break-in as described on page 6.
2. For immediate drag strip use, fit pistons using loose fit dimensions. Break in rings and pistons with 50 easy miles if possible. Piston and ring life will be reduced with loose fit dimensions.
3. Measure all pistons at widest point across thrust face, perpendicular to wristpin hole. Several measurements should be taken to locate widest point. Typically, this will be at bottom of piston skirt for pre-1984 Harley-Davidson® big twins, and approximately ½" below level of wristpin hole in pistons for Evolution® engines. If pre-1984 piston is notched for placement in rear cylinder, use measurement directly above notch for skirt measurement.
4. S&S® recommends #220-#280 grit stone for final honing of stock bore and Sidewinder®, S&S T124 and S&S big bore cylinders.
5. Follow procedure recommended in Harley-Davidson® service manual for boring and honing stock bore cylinders. Follow instructions included with S&S Cylinder Torque Plate Kit when boring and honing S&S stock bore and 3⅝" bore cylinders. Torque plates must be used when boring or honing aluminum cylinders to simulate compressive stress in an assembled engine. Cylinder bores will not be straight when engine is assembled, if torque plates are not used.

CAUTION

Failure to follow instructions and perform required clearancing, installation and/or break-in procedures may result in damage to pistons and/or other engine components not covered under warranty

PISTON INSTALLATION



Picture 1

NOTE: Pistons may have piston to piston clearance on both the front and rear. The notches must face each other. Pistons for pre-1984 application have no wristpin offset and can be installed in the front or rear. Pistons for 1984-up applications should be installed according to the marks on the top of the piston.

1. Check all installations for minimum of .060" clearance between pistons at closest point near bottom of stroke.
2. Check all installations for minimum of .060" clearance between pistons and flywheels at bottom of stroke. Replacement pistons may or may not have adequate clearance. Compare replacement pistons with ones being replaced and make corrections accordingly.

NOTE: In all cases it is the engine builder's responsibility to confirm proper clearances when assembling an engine. This is especially critical with performance components such as higher compression pistons and high lift camshafts. In addition to clearances mentioned, .060" valve-to-piston clearance must be confirmed.

CAUTION

Failure to establish proper clearances can result in severe engine damage not covered under warranty.

WRISTPIN RETAINER INSTALLATION

NOTE: Thoroughly clean wristpin before installation, paying particular attention to bore. Pass clean, lint-free cloth back and forth through wristpin bore several times to insure removal of contaminants.

1. If wristpin clips are used, insure that groove in piston is free of burrs and foreign matter.
2. Round "wire" style clips identical to and interchangeable with stock Harley-Davidson® Evolution® clips. Round wire clips require wristpins with specially chamfered ends. Install wire clips using procedure recommended in a Harley-Davidson® service manual. End of clip must rest over notch in piston below wristpin hole to allow removal of clip in future. Be sure clip is fully seated in groove.

RING INSTALLATION

1. Ring widths on some piston series are subject to change from time to time. Part numbers of rings originally supplied with pistons should be recorded for future reference in the event replacement rings are required. Measure rings to ensure that you get the correct replacement ring set.
2. The majority of ring kits presently supplied by S&S® contain a moly faced top ring, a cast, reverse torsion second ring, and a three piece oil ring. This may be confirmed as follows:
 - a. Top compression ring has a gray finish that is relatively light in color, and may or may not have a slight bevel along the inner edge. It has no dot or other identifying mark. The light color can best be recognized by comparing compression rings to each other beneath a good light. Install light colored ring without dot in top groove, bevel up. If there is no bevel, ring can be installed either side up.
 - b. Second compression ring has a darker, charcoal gray finish and slight bevel along inner surface. This ring has a dot. See Figure 1. Install in second or middle groove with dot up.
 - c. Oil rings are three piece type with two rails and one expander. Do not shorten expander for any reason! Installation is straightforward with one rail placed above expander, other rail below expander. Rails may be shortened to correct gap, but burrs must be carefully removed.

NOTE: In some cases, same expander is used for several bore sizes. Over-size rings will not necessarily have a larger expander.

CAUTION

Failure to remove burrs may cause engine damage. Incorrect installation of rings may result in poor performance, excessive oil consumption or engine damage.

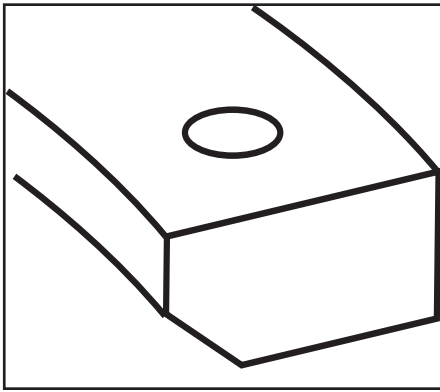

Figure 1

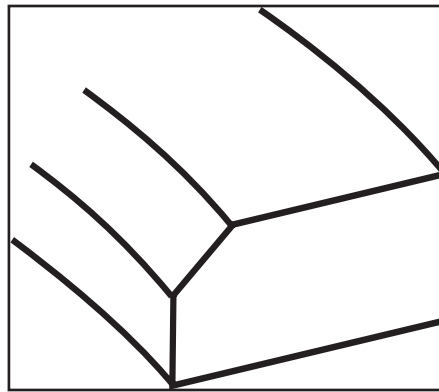

Figure 2

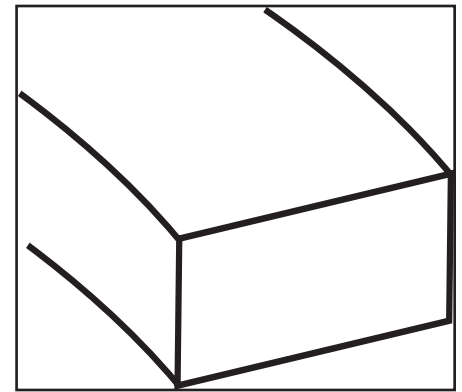

Figure 3

3. For ring kits in which section #2 above does not apply, compression rings may be of plain cast iron type, chrome faced cast iron type, moly faced cast type or chrome type.

- a. The most common combinations are:
 - i. Two chrome faced cast rings
 - ii. One chrome faced cast ring & one plain cast ring.
 - iii. One moly faced cast ring & one plain cast ring.
- b. Install as follows:
 - i. Chrome faced or moly faced ring always goes in top groove
 - ii. Plain cast ring usually goes in second groove. Plain cast type is usually a reverse torsion ring distinguished by an inside diameter bevel on one side of ring and a "dot" or oversize mark on other side. **See Figure 1** above. If two cast iron compression rings are supplied in a set, check to see if one is reverse torsion style ring with dot and bevel. Reverse torsion style ring always goes in second groove with dot up if present.
- c. The following rules apply to compression ring identification and placement. Rules are listed in order of priority. In other words, if both Rule #2 and Rule #4 apply, for example, Rule #2 will be followed and Rule #4 ignored.
 - i. Chrome or moly ring goes in top groove.
 - ii. Cast iron regular or reverse torsion ring goes in second groove.
 - iii. Any identifying "pip" marks, dots or oversize marks go to top of piston.
 - iv. Ring with one dot goes in top groove, ring with two dots goes in second groove.
 - v. If both rings are identical and have one dot or two dots, either ring can go in either groove.
 - vi. If ring has dot and inside diameter bevel, dot goes to top of piston. **See Figure 1** above.
 - vii. If ring has no dot but does have inside diameter bevel, bevel goes to top of piston. **See Figure 2** above.
 - viii. If ring has no dots and no bevel, it can go either way. **See Figure 3** above.

4. Ring Gap Measurements

- a. Compression ring end gap on big twins with $3\frac{7}{16}$ ", $3\frac{1}{2}$ " and $3\frac{5}{8}$ " bore is .014" to .022".
- b. End gap on all other compression rings is .016" to .024".
- c. Oil ring rail end gap on big twins with $3\frac{7}{16}$ ", $3\frac{1}{2}$ " and $3\frac{5}{8}$ " bore is .015" to .035".

NOTE: In certain instances, the next oversize ring set may be supplied with pistons, for example +.060" oversize rings with +.050" pistons. In this case end gaps must be measured and rings filed as necessary. Ends must then be carefully deburred.

5. Install ring support rail in front piston so that the end gap is toward the rear of the cylinder (90° from wristpin). Install ring support rail on rear piston so that the end gap is toward front of the cylinder (90° from wristpin).

6. Ring Gap Placement

- a. Oil ring
 - i. Expander gap must be in center of thrust face (rear of piston), or 90° from wristpin.
 - ii. Bottom rail gap should be approximately 1.5" or 45° to right of expander gap.
 - iii. Top rail gap should be approximately 1.5" or 45° to left of expander gap.

NOTE: Confirm that ends of expander do not overlap during installation. Properly installed expander will appear larger than piston but will compress when cylinder installed.

- b. Top compression ring gap should be 135° or approximately $4\frac{1}{2}$ " to left of oil expander gap.
- c. Second compression ring gap should be 135° or approximately $4\frac{1}{2}$ " to right of oil expander gap.

***NOTE:** Fit wristpins at .0007" to .0014."

ENGINE BREAK-IN PROCEDURE

NOTES:

S&S® engines are designed for high performance and as such are not as tolerant of inadequate break-in. Correct break-in will assure longer engine life and will prevent unnecessary engine damage. Engine damage caused by improper break-in is not covered under the S&S warranty. If new pistons have not been installed, only steps A, B, and C are required. If new pistons have been installed, all break in steps are required.

1. Initial start up. Run engine approximately one minute at 1250-1750 rpm. DO NOT crack throttle or subject to any loads during this period as head gaskets are susceptible to failure at this time. During this time check to see that oil pressure is normal, that oil is returning to the oil tank, and that no leaks exist.
2. Shut off engine and thoroughly check for any leaks or other problems. Let engine cool to the touch
3. After engine has cooled, start up again and allow the motor to build some heat. Engine should be run no longer than three to four minutes. When the cylinders become warm/hot to the touch (approximately 150°) shut the motor down and let it cool to room temp. Follow the same cautions as for the initial start-up, and continue to watch for problems.



Failure to deburr rings may result in engine damage.

4. Repeat this procedure 3 or 4 times. Each successive time it should take slightly longer to warm up and you can increase the temp slightly each time (+10°). You can be more liberal each time with the rpm, gently vary rpm continuously from idle up to 2500 rpm in the final cycle. Don't be too concerned with final carb settings at this time because idle speed and mixture cannot be correctly set until the motor reaches full operating temperature. The motor should not reach that temperature during these cycles. Do not allow engine temperature to become excessive. After the motor has cooled to room temperature for the final time you are ready to start the 500 mile engine break-in process.
5. The first 50 miles are most critical for new rings and piston break-in. Engine damage is most likely to occur during this period. Keep heat down by not exceeding 2500 rpm. Avoid lugging the motor, riding in hot weather or in traffic. Vary the engine speed. Do not lug the engine. We recommend changing the oil at 50 miles.
6. The next 500 miles should be spent running engine no faster than 3500 rpm or 60 mph. Avoid continuous steady speeds, and do not lug the engine. Vary engine rpm. We recommend changing the oil again at 500 miles.



Lugging or running engine prematurely at sustained high rpm may result in damage to pistons and other engine components. S&S® voids its guarantee if engine is not broken in properly.

7. For the balance of the first 1000 miles the motor can be run in a normal but conservative manner. You can be more liberal with the rpm range and motorcycle can be operated at normal highway speeds. Avoid overheating or putting any hard strain on the engine: no drag racing, dyno runs, excessive speed, trailer towing or sidecar operation.
8. After 1000 miles, verify carburetor jetting and adjustment. Change the engine oil. Motorcycle can now be operated normally.
9. Have Fun!

SET PART #	DESCRIPTION	PART # STAMPED ON PISTON	CLOSE FIT	LOOSE FIT	OLD S&S PNs THAT ARE SUPERCEDED					
106-5495	Piston Set 3/16" Std, LC, Forged, .791" WP, 1936-'84 bt	106-5491	.0035" to .004"	.0045" to .0055"	92-2500	92-2510				
106-5496	Piston Set 3/16" +.010", LC, Forged, .791" WP, 1936-'84 bt	106-5492	.0035" to .004"	.0045" to .0055"	92-2501	92-2511				
106-5497	Piston Set 3/16", +.020", LC, Forged, .791" WP, 1936-'84 bt	106-5493	.0035" to .004"	.0045" to .0055"	92-2502	92-2512				
106-5498	Piston Set 3/16", +.030", LC, Forged, .791" WP, 1936-'84 bt	106-5494	.0035" to .004"	.0045" to .0055"	92-2503	92-2513				
106-5773	Piston Set 3/16", +.040", LC, Forged, .791" WP, 1936-'84 bt	106-5774	.0035" to .004"	.0045" to .0055"	92-2504	92-2514				
106-5503	Piston Set 3/16", Standard, HC, .791" WP, 1936-'84 bt	106-5499	.0035" to .004"	.0045" to .0055"						
106-5504	Piston Set 3/16", +.010", HC, .791" WP, 1936-'84 bt	106-5500	.0035" to .004"	.0045" to .0055"						
106-5505	Piston Set 3/16", +.020", HC, .791" WP, 1936-'84 bt	106-5501	.0035" to .004"	.0045" to .0055"						
106-5506	Piston Set 3/16", +.030", HC, .791" WP, 1936-'84 bt	106-5502	.0035" to .004"	.0045" to .0055"						
106-5775	Piston Set 3/16", +.040", HC, .791" WP, 1936-'84 bt	106-5776	.0035" to .004"	.0045" to .0055"						
106-5511	Piston Set 3/16", Standard, LC, .791" WP, 1936-'84 bt	106-5507	.0035" to .004"	.0045" to .0055"	92-2606	92-2616				
106-5512	Piston Set 3/16", +.010", LC, .791" WP, 1936-'84 bt	106-5508	.0035" to .004"	.0045" to .0055"	92-2607	92-2617				
106-5513	Piston Set 3/16", +.020", LC, .791" WP, 1936-'84 bt	106-5509	.0035" to .004"	.0045" to .0055"	92-2608	92-2618				
106-5514	Piston Set 3/16", +.030", LC, .791" WP, 1936-'84 bt	106-5510	.0035" to .004"	.0045" to .0055"	92-2609	92-2619				
106-5519	Piston Set 3/16", Standard, HC, .791" WP, 1936-'84 bt	106-5515	.0035" to .004"	.0045" to .0055"	92-2506	92-2516				
106-5520	Piston Set 3/16", +.010", HC, .791" WP, 1936-'84 bt	106-5516	.0035" to .004"	.0045" to .0055"	92-2507	92-2517				
106-5521	Piston Set 3/16", +.020", HC, .791" WP, 1936-'84 bt	106-5517	.0035" to .004"	.0045" to .0055"	92-2508	92-2518				
106-5522	Piston Set 3/16", +.030", HC, .791" WP, 1936-'84 bt	106-5518	.0035" to .004"	.0045" to .0055"	92-2509	92-2519				
920-0073	Piston Set 3-7/16" x 4-3/4", Standard, LC, .791" WP, 1936-'84 bt	920-0072	.0035" to .004"	.0045" to .0055"	92-2800	92-2720	92-2730	92-2900		
920-0075	Piston Set 3-7/16" x 4-3/4", +.010", LC, .791" WP, 1936-'84 bt	920-0074	.0035" to .004"	.0045" to .0055"	92-2801	92-2721	92-2731	92-2901		
920-0077	Piston Set 3-7/16" x 4-3/4", +.020", LC, .791" WP, 1936-'84 bt	920-0076	.0035" to .004"	.0045" to .0055"	92-2802	92-2722	92-2732	92-2902		
920-0079	Piston Set 3-7/16" x 4-3/4", +.030", LC, .791" WP, 1936-'84 bt	920-0078	.0035" to .004"	.0045" to .0055"	92-2803	92-2723	92-2733	92-2903		
920-0081	Piston Set 3-7/16" x 4-3/4", +.040", LC, .791" WP, 1936-'84 bt	920-0080	.0035" to .004"	.0045" to .0055"	92-2804	92-2724	92-2734	92-2904		
920-0083	Piston Set 3-7/16" x 4-3/4", +.050", LC, .791" WP, 1936-'84 bt	920-0082	.0035" to .004"	.0045" to .0055"	92-2805	92-2725	92-2735	92-2905		
920-0085	Piston Set 3-7/16" x 4-3/4", +.060", LC, .791" WP, 1936-'84 bt	920-0084	.0035" to .004"	.0045" to .0055"	92-2806	92-2726	92-2736	92-2906		
920-0087	Piston Set 3-7/16" x 4-3/4", +.070", LC, .791" WP, 1936-'84 bt	920-0086	.0035" to .004"	.0045" to .0055"	92-2807	92-2727	92-2737	92-2907		
920-0089	Piston Set 3-7/16" x 4-3/4", +.080", LC, .791" WP, 1936-'84 bt	920-0088	.0035" to .004"	.0045" to .0055"	92-2808	92-2728	92-2738	92-2908		
920-0091	Piston Set 3-7/16" x 4-3/4", +.090", LC, .791" WP, 1936-'84 bt	920-0090	.0035" to .004"	.0045" to .0055"	92-2809	92-2729	92-2739	92-2909		
106-5527	Piston Set 3/16" x 4 3/4", Std, HC, .791" WP, 1936-'84 bt	106-5523	.0035" to .004"	.0045" to .0055"	92-2800	92-2720	92-2730	92-2900		
106-5528	Piston Set 3/16" x 4 3/4", +.010", HC, .791" WP, 1936-'84 bt	106-5524	.0035" to .004"	.0045" to .0055"	92-2801	92-2721	92-2731	92-2901		
106-5529	Piston Set 3/16" x 4 3/4", +.020", HC, .791" WP, 1936-'84 bt	106-5525	.0035" to .004"	.0045" to .0055"	92-2802	92-2722	92-2732	92-2902		
106-5530	Piston Set 3/16" x 4 3/4", +.030", HC, .791" WP, 1936-'84 bt	106-5526	.0035" to .004"	.0045" to .0055"	92-2803	92-2723	92-2733	92-2903		
106-5777	Piston Set 3/16" x 4 3/4", +.040", HC, .791" WP, 1936-'84 bt	106-5783	.0035" to .004"	.0045" to .0055"	92-2804	92-2724	92-2734	92-2904		
106-5778	Piston Set 3/16" x 4 3/4", +.050", HC, .791" WP, 1936-'84 bt	106-5784	.0035" to .004"	.0045" to .0055"	92-2805	92-2725	92-2735	92-2905		
106-5779	Piston Set 3/16" x 4 3/4", +.060", HC, .791" WP, 1936-'84 bt	106-5785	.0035" to .004"	.0045" to .0055"	92-2806	92-2726	92-2736	92-2906		
106-5780	Piston Set 3/16" x 4 3/4", +.070", HC, .791" WP, 1936-'84 bt	106-5786	.0035" to .004"	.0045" to .0055"	92-2807	92-2727	92-2737	92-2907		
106-5781	Piston Set 3/16" x 4 3/4", +.080", HC, .791" WP, 1936-'84 bt	106-5787	.0035" to .004"	.0045" to .0055"	92-2808	92-2728	92-2738	92-2908		
106-5782	Piston Set 3/16" x 4 3/4", +.090", HC, .791" WP, 1936-'84 bt	106-5788	.0035" to .004"	.0045" to .0055"	92-2809	92-2729	92-2739	92-2909		
106-5535	Piston Set 3/16" Standard, HC, .791" WP, 1936-'84 bt	106-5531	.0035" to .004"	.0045" to .0055"	92-1800	92-1830	92-1840	92-1620	92-1630	92-1640
106-5536	Piston Set 3/16" +.010", HC, .791" WP, 1936-'84 bt	106-5532	.0035" to .004"	.0045" to .0055"	92-1801	92-1831	92-1841	92-1621	92-1631	92-1641
106-5537	Piston Set 3/16" +.020", HC, .791" WP, 1936-'84 bt	106-5533	.0035" to .004"	.0045" to .0055"	92-1802	92-1832	92-1842	92-1622	92-1632	92-1642
106-5538	Piston Set 3/16" +.030", HC, .791" WP, 1936-'84 bt	106-5534	.0035" to .004"	.0045" to .0055"	92-1803	92-1833	92-1843	92-1623	92-1633	92-1643
106-5789	Piston Set 3/16" +.060", HC, .791" WP, 1936-'84 bt	106-5790	.0035" to .004"	.0045" to .0055"	92-1806	92-1836	92-1846	92-1626	92-1636	92-1646
106-5542	Piston Set 3/16" +.010", HC, .791" WP, 1972-'85 xl	106-5539	.0035" to .004"	.0045" to .0055"	92-3701					
106-5543	Piston Set 3/16" +.020", HC, .791" WP, 1972-'85 xl	106-5540	.0035" to .004"	.0045" to .0055"	92-3702					
106-5544	Piston Set 3/16" +.030", HC, .791" WP, 1972-'85 xl	106-5541	.0035" to .004"	.0045" to .0055"	92-3703					
106-5791	Piston Set 3/16" +.060", HC, .791" WP, 1972-'85 xl	106-5792	.0035" to .004"	.0045" to .0055"	92-3706					
106-5548	Piston Set 3/16" Standard, DD, .792" WP, 883 to 1200 conversion, 1986-up xl	106-5545	.0025" to .0030"	.0035 to .0045"	92-2446					
106-5549	Piston Set 3/16", +.010", DD, .792" WP, 883 to 1200 conversion, 1986-up xl	106-5546	.0025" to .0030"	.0035 to .0045"	92-2447					
106-5550	Piston Set 3/16", +.020", DD, .792" WP, 883 to 1200 conversion, 1986-up xl	106-5547	.0025" to .0030"	.0035 to .0045"	92-2448					
106-5554	Piston Set 3/16", Standard, FD, .792" WP, 1984-'99 bt	106-5551	.0025" to .0030"	.0035 to .0045"	92-2426					
106-5555	Piston Set 3/16", +.010", FD, .792" WP, 1984-'99 bt	106-5552	.0025" to .0030"	.0035 to .0045"	92-2427					
106-5556	Piston Set 3/16", +.020", FD, .792" WP, 1984-'99 bt	106-5553	.0025" to .0030"	.0035 to .0045"	92-2428					
106-5793	Piston Set 3/16", +.030", FD, .792" WP, 1984-'99 bt	106-5794	.0025" to .0030"	.0035 to .0045"	92-2429					

Instruction 510-0003
05-11-2010

Copyright © 2010
by S&S® Cycle, Inc.

All rights reserved.
Printed in the U.S.A.

S&S® Cycle, Inc.

14025 Cty Hwy G PO Box 215
Viola, Wisconsin 54664

Phone: 608-627-1497 • Fax: 608-627-1488
Technical Service Phone: 608-627-TECH (8324)
Technical Service Email: sstech@sscycle.com
Website: www.sscycle.com



Installation: Shovelhead Head Bolts & Washers



See Fig.1, below left. One side of the washer has a special chamfer. This provides clearance to the radius on the underside of the head bolt.

See Fig. 2, below right. The chamfered side of each washer **MUST** face towards the head bolt flange as shown. Incorrect placement of the chamfered side of the head bolt washers may cause the washers to crack and break resulting in the head bolts coming loose.

Refer to the appropriate Service Manual for complete reassembly procedures and torque specifications.

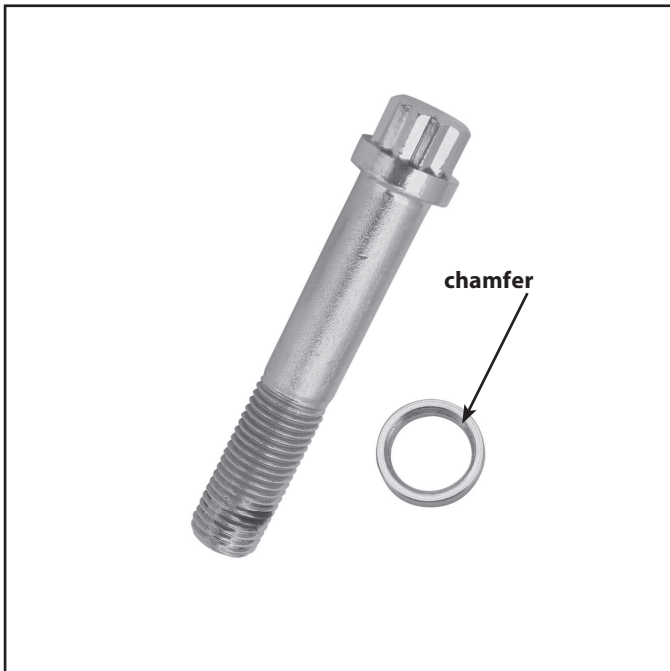

Fig. 1

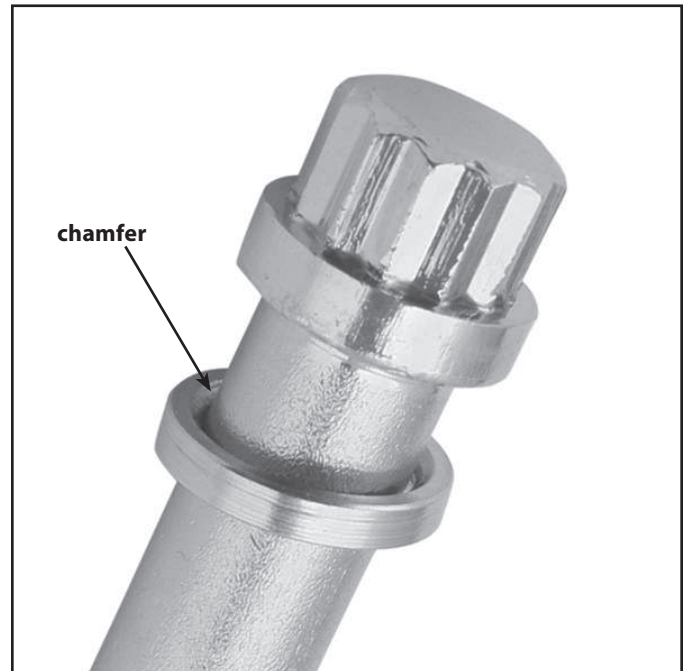

Fig. 2

**Instruction 510-0005
12-30-13**

Copyright © 2009, 2010, 2013
by S&S® Cycle, Inc.

All rights reserved.
Printed in the U.S.A.

S&S® Cycle, Inc.

**14025 Cty Hwy G PO Box 215
Viola, Wisconsin 54664**

Phone: 608-627-1497 • Fax: 608-627-1488
Technical Service Phone: 608-627-TECH (8324)
Technical Service Email: sstech@sscyle.com
Website: www.sscyle.com



Installation Instructions for S&S® Piston Rings

DISCLAIMER:

S&S parts are designed for high performance, closed course, racing applications and are intended for the very experienced rider only. The installation of S&S parts may void or adversely affect your factory warranty. In addition such installation and use may violate certain federal, state, and local laws, rules and ordinances as well as other laws when used on motor vehicles used on public highways, especially in states where pollution laws may apply. Always check federal, state, and local laws before modifying your motorcycle. It is the sole and exclusive responsibility of the user to determine the suitability of the product for his or her use, and the user shall assume all legal, personal injury risk and liability and all other obligations, duties, and risks associated therewith.

The words Harley®, Harley-Davidson®, H-D®, Sportster®, Evolution®, and all H-D part numbers and model designations are used in reference only. S&S Cycle is not associated with Harley-Davidson, Inc.

SAFE INSTALLATION AND OPERATION RULES:

Before installing your new S&S part it is your responsibility to read and follow the installation and maintenance procedures in these instructions and follow the basic rules below for your personal safety.

- Gasoline is extremely flammable and explosive under certain conditions and toxic when breathed. Do not smoke. Perform installation in a well ventilated area away from open flames or sparks.
- If motorcycle has been running, wait until engine and exhaust pipes have cooled down to avoid getting burned before performing any installation steps.
- Before performing any installation steps disconnect battery to eliminate potential sparks and inadvertent engagement of starter while working on electrical components.
- Read instructions thoroughly and carefully so all procedures are completely understood before performing any installation steps. Contact S&S with any questions you may have if any steps are unclear or any abnormalities occur during installation or operation of motorcycle with a S&S part on it.
- Consult an appropriate service manual for your motorcycle for correct disassembly and reassembly procedures for any parts that need to be removed to facilitate installation.
- Use good judgment when performing installation and operating motorcycle. Good judgment begins with a clear head. Don't let alcohol, drugs or fatigue impair your judgment. Start installation when you are fresh.
- Be sure all federal, state and local laws are obeyed with the installation.
- For optimum performance and safety and to minimize potential damage to carb or other components, use all mounting hardware that is provided and follow all installation instructions.
- Motorcycle exhaust fumes are toxic and poisonous and must not be breathed. Run motorcycle in a well ventilated area where fumes can dissipate.

IMPORTANT NOTICE:

Statements in this instruction sheet preceded by the following words are of special significance.



WARNING

Means there is the possibility of injury to yourself or others.



CAUTION

Means there is the possibility of damage to the part or motorcycle.

NOTE

Other information of particular importance has been placed in italic type.

S&S recommends you take special notice of these items.

WARRANTY:

All S&S parts are guaranteed to the original purchaser to be free of manufacturing defects in materials and workmanship for a period of twelve (12) months from the date of purchase. Merchandise that fails to conform to these conditions will be repaired or replaced at S&S's option if the parts are returned to us by the purchaser within the 12 month warranty period or within 10 days thereafter.

In the event warranty service is required, the original purchaser must call or write S&S immediately with the problem. Some problems can be rectified by a telephone call and need no further course of action.

A part that is suspect of being defective must not be replaced by a Dealer without prior authorization from S&S. If it is deemed necessary for S&S to make an evaluation to determine whether the part was defective, a return authorization number must be obtained from S&S. The parts must be packaged properly so as to not cause further damage and be returned prepaid to S&S with a copy of the original invoice of purchase and a detailed letter outlining the nature of the problem, how the part was used and the circumstances at the time of failure. If after an evaluation has been made by S&S and the part was found to be defective, repair, replacement or refund will be granted.

ADDITIONAL WARRANTY PROVISIONS:

- (1) S&S shall have no obligation in the event an S&S part is modified by any other person or organization.
- (2) S&S shall have no obligation if an S&S part becomes defective in whole or in part as a result of improper installation, improper maintenance, improper use, abnormal operation, or any other misuse or mistreatment of the S&S part.
- (3) S&S shall not be liable for any consequential or incidental damages resulting from the failure of an S&S part, the breach of any warranties, the failure to deliver, delay in delivery, delivery in non-conforming condition, or for any other breach of contract or duty between S&S and a customer.
- (4) S&S parts are designed exclusively for use in Harley-Davidson® and other American v-twin motorcycles. S&S shall have no warranty or liability obligation if an S&S part is used in any other application.

RING INSTALLATION

- 1- Ring widths on S&S® pistons may change from time to time. Part numbers of rings originally supplied with pistons should be recorded for future reference in the event replacement rings are required.
- 2- The majority of ring kits presently supplied by S&S® contain a moly faced top ring, a cast, reverse torsion second ring, and a three piece oil ring. This may be confirmed as follows:
 - A- Top compression ring has a gray finish that is relatively light in color, and may or may not have a slight bevel along the inner edge. **See Figure 1.** It generally has no dot or other identifying mark. The light color can best be recognized by comparing compression rings to each other beneath a good light. Install light colored ring in top groove, bevel up. If there is no bevel, ring can be installed either side up.
 - B- Second compression ring has a darker, charcoal gray finish and may slight bevel along inner surface, or a hook-like relief machined on the bottom of the outer diameter. **See Figures 2 and 3.** This ring may have a dot or letter on the top side. Install in second or middle groove with dot or letter up. Bevel on the inner surface or groove on outer diameter will face down.
 - C- Oil rings are three piece type with two rails and one expander. Do not shorten expander for any reason! Installation is straightforward with one rail placed above expander, other rail below expander. Rails may be shortened to correct gap, but burrs must be carefully removed.

NOTE: In some cases, same expander is used for several bore sizes. Oversize rings will not necessarily have a larger expander



Failure to remove burrs may cause engine damage. Incorrect installation of rings may result in poor performance, excessive oil consumption or engine damage.

- 3- Rings supplied in some ring kits may differ from those described in section #2. Compression rings may be of plain cast iron type, chrome, or moly faced cast iron.
 - A- The most common combinations are:
 - 1- Two chrome faced cast rings
 - 2- One chrome faced cast ring & one plain cast ring.
 - 3- One moly faced cast ring & one plain cast ring.
 - B- Install as follows:
 - 1- Chrome faced or moly faced ring always goes in top groove
 - 2- Plain cast ring usually goes in second groove. Plain cast type is usually a reverse torsion ring. distinguished by an inside diameter bevel on one side of ring, and a dot, letter, or oversize mark on other side. **See Figure 2.** Some second rings may have a hook shaped groove machined around the bottom of the the outer diameter. If two cast iron compression rings are supplied in a set, check to see if one has mark and bevel or hook shaped groove. These rings always go in second groove with marking up if present and bevel or groove facing down.
 - C- The following rules apply to compression ring identification and placement. Rules are listed in order of priority. In other words, if both Rule #2 and Rule #4 apply, for example, Rule #2 will be followed and Rule #4 ignored.
 - 1- Chrome or moly ring goes in top groove.
 - 2- Cast iron regular or reverse torsion ring goes in second groove.

- 3- Any identifying pip marks, dots, letters, or oversize marks go to top of piston.
- 4- Ring with one dot goes in top groove, ring with two dots goes in second groove.
- 5- If both rings are identical and have one dot or two dots, either ring can go in either groove.
- 6- If ring has dot or letter and inside diameter bevel, dot or letter goes to top of piston. **See Figure 2 and 3.**
- 7- If ring has no dot but does have inside diameter bevel, bevel goes to top of piston. **See Figure 1** below.
- 8- If ring has no dots and no bevel, it can go either way. **See Figure 4** below.

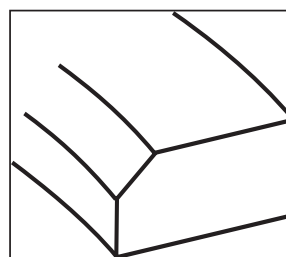

Figure 1

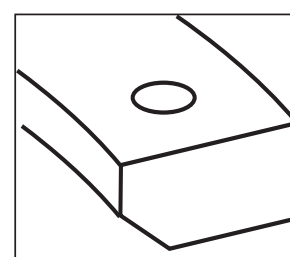

Figure 2

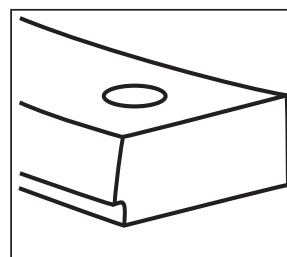

Figure 3

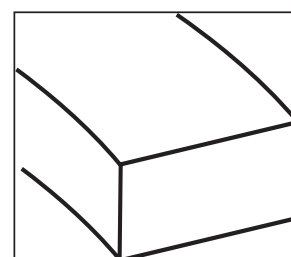

Figure 4

- 4- Ring Gap Measurements
 - A- Compression ring end gap on big twins with 3½" bore is .014" to .022".
 - B- End gap on all other compression rings is .016" to .024".
 - C- Oil ring rail end gap on big twins with 3½" bore is .015" to .035".
 - D- Oil ring rail end gap on all others is .015" to .035".
 - E- Compression ring end gap on big twins with 4½" bore is .017" to .025".
 - F- Oil ring rail end gap on big twins with 4½" bore is .015" to .035".

NOTE: In certain instances, the next oversize ring set may be supplied with pistons, for example +.060" oversize rings with +.050" pistons. In this case end gaps must be measured and rings filed as necessary. Ends must then be carefully deburred.



Failure to deburr rings may result in engine damage. Piston Series 92-1210, 92-1550, 92-1556, and 92-1560 have a ring support rail that needs to be installed before any other rings are installed.

5- If your piston application uses oil ring support rails, install ring support rail in front piston so that the end gap is toward the rear of the cylinder (90° from wristpin). Install ring support rail on rear piston so that the end gap is toward front of the cylinder (90° from wristpin). The dimple in the ring must face down and be installed in the gap above the wrist pin on both pistons. **See picture below.**

6- Ring Gap Placement

A- Oil ring

- 1- Expander gap must be in center of thrust face (rear of piston), or 90° from wristpin.
- 2- Bottom rail gap should be approximately 1.5" or 45° to right of expander gap.
- 3- Top rail gap should be approximately 1.5" or 45° to left of expander gap.

NOTE: Confirm that ends of expander do not overlap during installation. Properly installed expander will appear larger than piston but will compress when cylinder installed.

B- Top compression ring gap should be 135° or approximately 4½" to left of oil expander gap.

C- Second compression ring gap should be 135° or approximately 4½" to right of oil expander gap.

