



Part Number 150929C

PowerFlow Kit HONDA TRX 450R/ER

(incl. Air Filter (FR), Wire Cage, Aluminium Flange, Mounting Hardware)

Instructions:

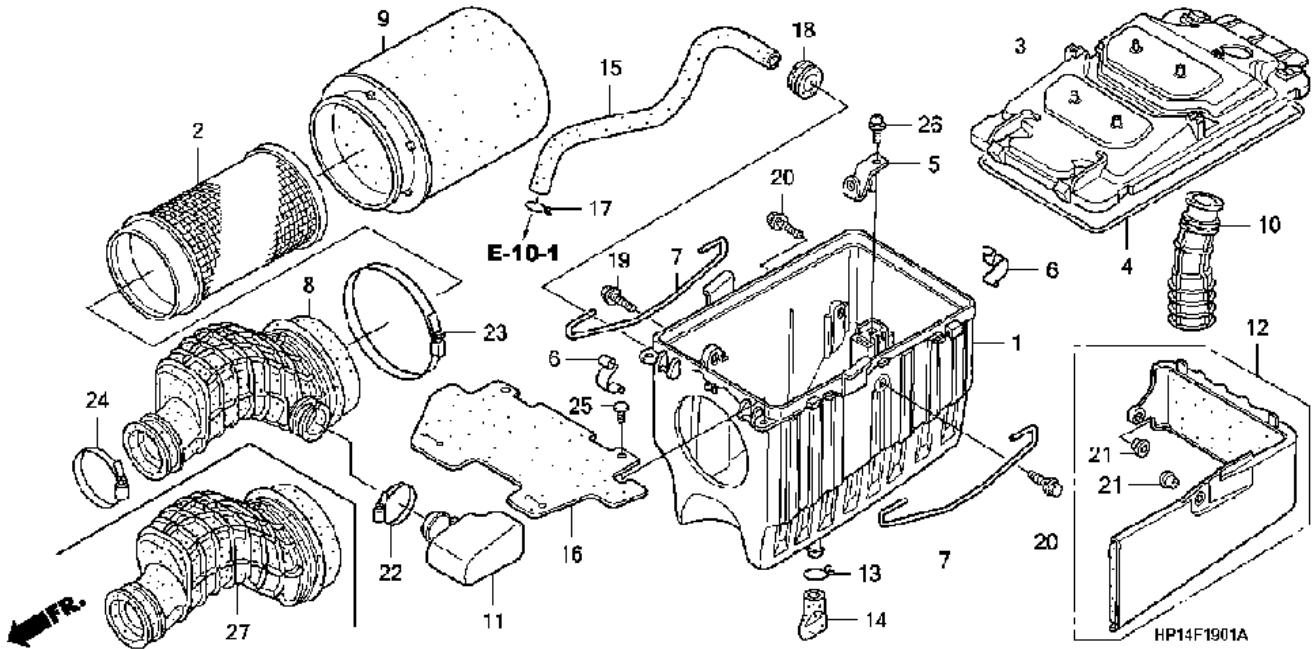

1. Access stock air filter assembly.
2. Remove stock air filter (9), filter cage (2), and mounting clamp (23).
3. Install Twin Air aluminum flange into the air boot (8) and tighten with clamp provided.
4. Install pre-oiled filter onto the metal cage supplied and secure cage to mounting flange with provided wing bolt.

If you have any other questions feel free to contact us. For contact information go to www.twinair.com or www.twinairusa.com.



Twin Air Replacement Parts and Accessories

- PowerFlow Replacement Air Filter: #150929FR
- Replacement Oil Filter: #140003
- Air Box Cleaning Cover: #160060

Twin Air Cleaning and Oiling Products

- Bio Dirt Remover: #159004
- Liquid Bio Power: #159017
- Bio Pack (Dirt Remover / Liquid Power): #159020
- Bio Spray: #159018M
- Twin Air Bio System: #159000BIO

For more details or to purchase these or other Twin Air products go to www.twinair.com, www.twinairusa.com or visit your local Twin Air Authorized Dealer.