

snapmaker | A350

QUICK START GUIDE

$\int_0^{\text{Wonderful}} \text{make}(x)dx = \text{snapmaker}$



Make Something Wonderful

Three years ago, when we were designing the Snapmaker Original, we broke the rules of traditional desktop 3D printers and created the first modular 3-in-1 3D printer on the market. At first, The Verge and a lot of other reviewers doubted that “Snapmaker is an upcoming Kickstarter project with a lofty goal: to be the holy trinity for at-home makers by using detachable modules to convert between a 3D printer, a CNC carver, and a laser engraver,” and “At the price that

Snapmaker is selling, it’s possible the whole thing is too good to be true.” We knew people had a lot of uncertainty about our project and were hesitant to back us because of the complexity of designing and making such a product. Despite all the doubts, we worked hard on pushing the boundaries of possibility, and we eventually made the impossible possible. Not only did we fulfill all the rewards, but we also sold over 10,000 units all over the world in 2018. And in 2019,

we launched the Snapmaker 2.0. We went beyond our limits once again. Our goal is to build a system behind our modular 3D printers and give you the best maker tools that can work for all your projects. As creatives we all desire to make something wonderful and creativity makes us feel alive. The Snapmaker 2.0 will help you turn your idea into reality. This quick start guide will guide you through your maker journey and take you from building your own 3D

Printer/Laser Cutter/CNC Carver to making your first creations utilizing all these tools. Congratulations on becoming part of the Snapmaker community! Thousands of people like you are using the Snapmaker to explore, make, and share in the world of making. We are strong believers that wonderful things will happen when creative minds meet the ideal tools. Have fun making and see you out there!

Team Snapmaker



Welcome to the world of making

Happy Making

This machine is built for innovators. Our goal is to assist you to make the world a better place with a machine we built with love. The difference could be something as small as a Christmas gift, or something as ambitious as exploring unknown territories of our mankind. Dream big and make it happen.



Modular System

Snapmaker is not only a 3D printer, but also a powerful machine that you can modify with all kinds of addons. You can equip your Snapmaker with an enclosure to protect you and your family from laser and dirt particles. New addons are coming soon with more exciting features. Please stay tuned.



CONTENTS

-
- 01 Before You Start
-
- 12 Machine Assembly
-
- 38 3D Printing
-
- 56 Laser Engraving and Cutting
-
- 72 CNC Carving
-



1.1 Disclaimer

Please read and understand the contents of the manual of this product carefully. Failure to read the manual may lead to personal injury, inferior results or damage to the Snapmaker products. Always make sure that anyone who uses this product knows and understands the contents of this manual to make the most out of it. This manual is provided for reference purposes only, we do not warrant the accuracy or completeness of the information provided by this manual. We reserve the right to modify or revise this manual in our sole discretion at any time without notice, users can download the most up-to-date version of this manual on our official website.

When making objects using Snapmaker products, users remain responsible to ensure that they do not infringe any third party intellectual property rights or violate any applicable laws or regulations. The conditions or methods used for assembling, handling, storage, use, maintaining or disposal of this product are beyond our control. For this reason, we do not assume responsibility and expressly disclaim liability for loss, injuries, damage, or expense arising out of or in any way connected with the assembly, handling, storage, use, maintaining or disposal of this product.

1.2 Intended Use

Snapmaker modular 3D printers come with improved 3-in-1 capabilities for 3D printing, laser engraving / cutting, and CNC carving. Snapmaker modular 3D printers are ideal choice for beginners who are just getting started, hobbyists who prefer more customized options, as well as engineers and designers who want to make large objects or accurate parts with outstanding print / engrave / cut / carve quality. Snapmaker modular 3D printers are intended for use under the guidelines provided in the product manual. When making objects using Snapmaker modular 3D printers, users remain responsible to qualify and validate the application of the created object for its intended use, especially critical for applications in strictly regulated areas like medical devices and aeronautics.

1.3 Safety and Compliance

General Safety Information

- Always operate this machine indoors on a solid horizontal table or workbench.
- Do not expose this machine to rain or wet conditions.
- Keep children and bystanders away while operating this machine. It requires the supervision and assistance of an adult when children use this machine.
- Stay alert, watch what you are doing and use common sense when operating this machine. Do not use this machine while you are tired or under the influence of drugs, alcohol or medication.
- Do not reach inside the machine or touch the moving parts while the machine is still in operation. An injury may be caused by its moving parts.
- Do not leave the machine unattended while it is still on.

In all EU member states, operation of 5150-5250 MHz is restricted to indoor use only.



AT	BE	CY	CZ	DK	EE	FI
FR	DE	EL	HU	IE	IT	LV
LT	LU	MT	NL	PL	PT	SK
SI	ES	SE	UK	BG	RO	HR

Stop using this product if any of the following occurs. Turn off the machine immediately.

- There is a fire in this machine which persists after the machine turns off.
- The machine stops unexpectedly.
- You see any damage to the interior components of this machine.
- You notice unusual light or an unusual sound coming from this machine that was not occurring previously.

3D Printing Safety

- Do not touch the nozzle, print sheet and heated bed when the machine is printing or heating.
- Always unplug the machine before performing maintenance or modifications.
- Set up the printer in a well-ventilated place when printing with ABS. The melting of some materials may release toxic fumes.

Laser Safety

- The laser tool is a class 4 laser. You are only allowed to operate the laser tool if you have a sufficient specialized and safety knowledge: You must know the physical properties as well as the biological effects of laser radiation, the legal bases and rules of technology, the laser classes and their dangers, the implementation of safety measures.
- Operate the machine with an enclosure covered and wear the Laser Safety Goggles.
- Never expose yourself to the laser beam. Proper use and care of the laser tool are essential to safe operation.
- Operate the laser tool when it is exhausted to the outdoors or through an air filter. The melting of some materials may release toxic fumes.
- Always unplug the machine before performing maintenance or modifications.
- Remove any reflective material from the work area underneath the laser module. Reflective material can cause uncontrolled scattered radiation.

CNC Safety

- Age Recommendation: For experienced users and users age 18 and above.
- Put the machine into an enclosure and wear the CNC Safety Goggles.
- Always have the material securely clamped. Never attempt to hold the workpiece with your hands throughout the CNC carving process.
- Always unplug the machine before performing maintenance or modifications.
- If the bit or workpiece become jammed or bogged down, turn off the machine immediately. Wait for all moving parts to stop and unplug the tool, then work to free the jammed material.
- Do not touch the bit or collet after use. After usage, the bit and collet are too hot to be touched with bare hands.
- Some dust created by CNC carving and cutting contains chemicals known to cause cancer or other reproductive harm. To reduce your exposure to these chemicals: work in a well-ventilated area and work with safety equipment, such as those dust masks that are specially designed to filter out microscopic particles.

FCC Compliance

This equipment has been tested and found to comply with the limits for a Class B digital device, pursuant to part 15 of the FCC Rules. These limits are designed to provide reasonable protection against harmful interference in a residential installation. This equipment generates, uses and can radiate radio frequency energy and, if not installed and used in accordance with the instructions, may cause harmful interference to radio communications. However, there is no guarantee that interference will not occur in a particular installation. If this equipment does cause harmful interference to radio or television reception, which can be determined by turning the equipment off and on, the user is encouraged to try to correct the interference by one or more of the following measures:

- Reorient or relocate the receiving antenna.
- Increase the separation between the equipment and receiver.

- Connect the equipment into an outlet on a circuit different from that to which the receiver is connected.
- Consult the dealer or an experienced radio / TV technician for help.

Caution: Any changes or modifications to this device not explicitly approved by manufacturer could void your authority to operate this equipment.

This device complies with part 15 of the FCC Rules. Operation is subject to the following two conditions:

(1) This device may not cause harmful interference, and (2) this device must accept any interference received, including interference that may cause undesired operation.

This equipment complies with FCC radiation exposure limits set forth for an uncontrolled environment. This equipment should be installed and operated with minimum distance 20cm between the radiator & your body.

ISED Compliance

This device complies with Innovation, Science and Economic Development Canada License exempt RSS standard(s). Operation is subject to the following two conditions:

(1) this device may not cause harmful interference, and (2) this device must accept any interference received, including interference that may cause undesired operation of the device.







Le présent appareil est conforme aux CNR d'Innovation, Sciences et Développement économique Canada applicables aux appareils radio exempts de licence. L'exploitation est autorisée aux deux conditions suivantes :

(1) l'appareil n' doit pas produire de brouillage, et (2) l'utilisateur de l'appareil doit accepter tout brouillage radioélectrique subi, même si le brouillage est susceptible d'en compromettre le fonctionnement.

The device is compliance with RF exposure guidelines, users can obtain Canadian information on RF exposure and compliance. The minimum distance from body to use the device is 20cm.

Le présent appareil est conforme Après examen de ce matériel aux conformité ou aux limites d'intensité de champ RF, les utilisateurs peuvent sur l'exposition aux radiofréquences et conformité d'acquérir les informations correspondantes. La distance minimale du corps à utiliser le dispositif est de 20cm.

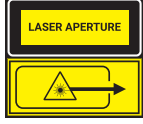
1.4 Labels on Your Snapmaker

Safety Labels	Hazard	Warning	Location
	Hot surface	Taking care to avoid contacting with a hot surface.	On the 3D Printing Module, Print Sheet and Heated Bed
	Sharp elements	Taking care to avoid injury from sharp elements (e.g. CNC bits).	On the CNC module
 	Laser radiation	Class 4 laser product. Avoid eyes or skin exposure to direct or scattered radiation.	On the Laser Module
 	Laser aperture	Laser radiation is emitted from this aperture.	On the Laser Module

1.5 Specifications

General	
Frame Material Connectivity Touchscreen Software	Aluminum Alloys Wi-Fi, USB Cable, USB Disk 5" TFT, Android System Snapmaker Luban. You can also use 3rd party software to generate G-code files
Supported File Types Supported OS Rated Power	STL, OBJ, SVG, JPEG, PNG, more formats to be added MacOS, Windows, Linux 320W
3D Printing	
Build Volume	A150: 160 x 160 x 145 mm A250: 230 x 250 x 235 mm A350: 320 x 350 x 330 mm
Heated Bed	A150: Up to 110°C A250: Up to 100°C A350: Up to 80°C
Layer Resolution Nozzle Temperature Nozzle Diameter Supported Materials	50 - 300 microns Up to 275°C 0.4 mm PLA, ABS, TPU, Wooded PLA, etc.
Laser	
Work Area Laser Wavelength Safety Class Supported Materials	A150: 160 x 160 mm A250: 230 x 250 mm A350: 320 x 350 mm 1 600mW 450nm Laser Diode 450 nm Class 4 Wood, leather, plastic, fabric, paper, nontransparent acrylic, etc.
CNC	
Work Area Shank Diameter Spindle Speed Supported Materials	A150: 160 x 160 x 90 mm A250: 230 x 250 x 180 mm A350: 320 x 350 x 275 mm 0.5 mm - 6.35 mm (0.02 - 0.25 inches) 6000 - 12,000 RPM Wood, acrylic, PCB, carbon fiber sheet, jade, etc.

Notice: The specifications listed might be slightly changed in any meaningful way when we refine this product.

1.6 Parts List



3D Printing Module x 1 Laser Module x 1 CNC Module x 1



Touchscreen x 1 Touchscreen Holder x 1 Controller x 1
 Toolhead Cable x 1 Y Conversion Cable x 1 Z Conversion Cable x 1



AC Power Cable x 1
 DC Power Cable x 1
 USB Cable x 1

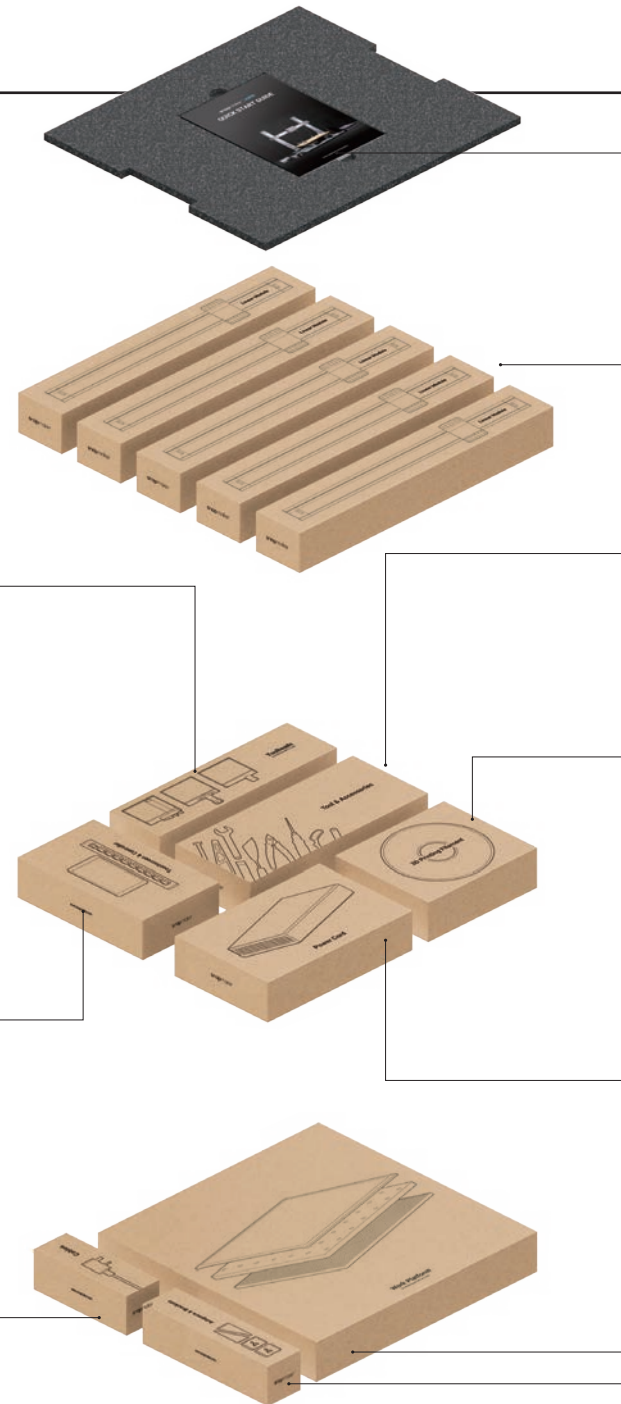
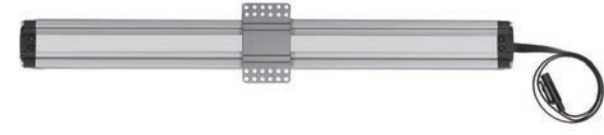

Base Plate x 1

Linear Module x 5



Filament x 1



Power Module x 1



Quick Start Guide x 1



Laser Safety Goggles x 1 Fixture Accessory x 4
 CNC Safety Goggles x 1 Arched Fixture x 4
 Filament Holder Sheet x 1
 Tool Box x 1 Filament Holder Tube x 1



Converter x 2
 Z-Axis Holder x 2

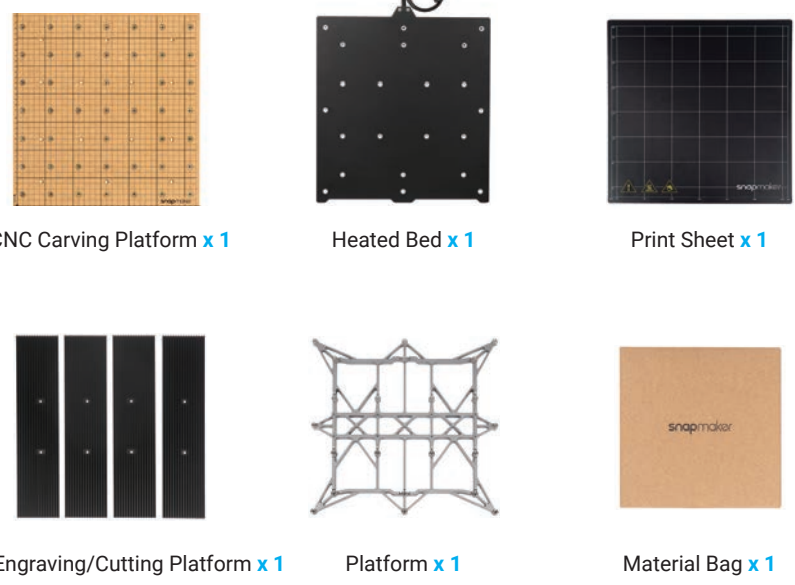

























CNC Carving Platform x 1 Heated Bed x 1 Print Sheet x 1
 Laser Engraving/Cutting Platform x 1 Platform x 1 Material Bag x 1









Tool Box

 M4 x 30 Screw x 12	 M4 x 10 Hex Socket Head Screw x 17	 M4 x 8 Screw x 68	 M4 x 10 Hex Flat Head Screw x 22
 M4 x 70 Screw x 4	 Wing Nut x 4	 Foot x 4 + M4 x 10 Hex Socket Head Screw x 4	 ER11 Collet (Only for 3.175 mm CNC Bits) x 1 + ER11 Nut x 1
 Divider x 6	 Cable Holder x 1	 Steel Strip Adjustor (For Maintenance) x 1	 Hot End Kit x 1
 Tweezer x 1	 Flat End Mill x 1	 Ball End Mill x 1	 Cable Tie x 1
 Silicone Plug x 8	 USB Disk x 1	 17mm Open-End Wrench x 1	
 Diagonal Pliers x 1	 Palette Knife x 1	 14mm Open-End Wrench x 1	 Screwdriver x 1



Material Bag



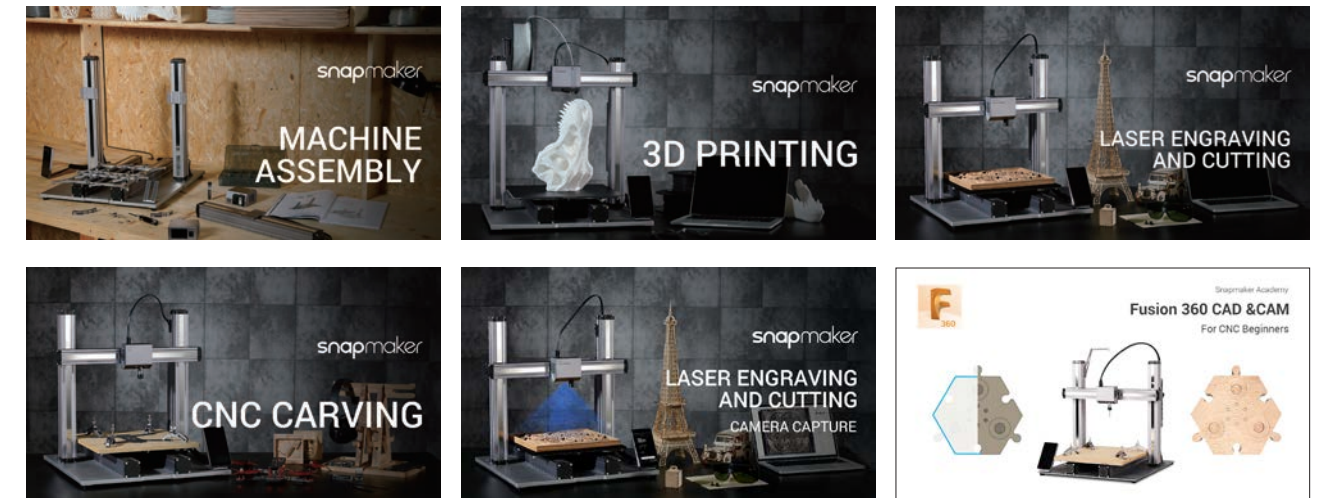

 CNC Material x 1	 Laser Material x 2	 Wiping Cloth x 1	 Calibration Card x 2
--	--	--	--

1.7 Video Tutorials

We provide both the video tutorials and Quick Start Guide which help you get started. You can either read this Quick Start Guide to finish assembly and begin your maker journey, or watch the video tutorials at <https://snapmaker.com>



1.8 Used Symbols

	CAUTION	Ignoring this type of message might result in malfunction or damage of the machine and injuries to users.
	NOTICE	Details you should be aware of throughout the process.
	TIPS	Tips offer you convenient operations and additional options.
		Make sure that the highlighted part is facing the right way.
		Do not tighten the screws when this symbol appears. Always tighten the screws when it is absent.

1.9 Get the Screwdriver Ready



The screwdriver head H 2.5 is used for assembling the machine. The other heads are used for maintenance. Make sure the screw head holder has been put back inside of the handle before use.

MACHINE ASSEMBLY



01/22

Attach the feet to the Base Plate.

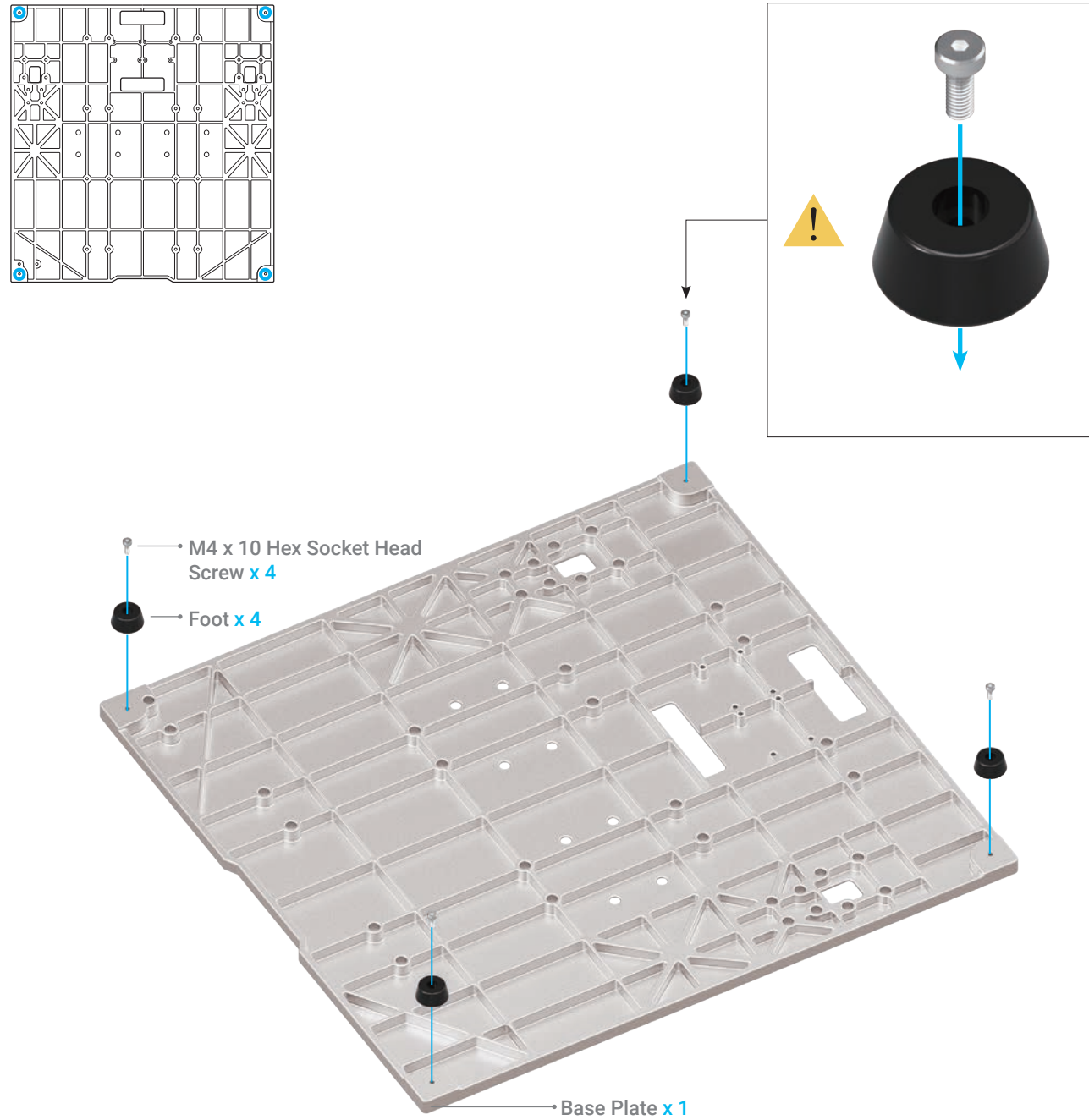

02/22

Make sure the sliders are aligning with each other. If not, you can move them to the same position as illustrated.

Please hold the linear modules carefully to prevent them from falling.

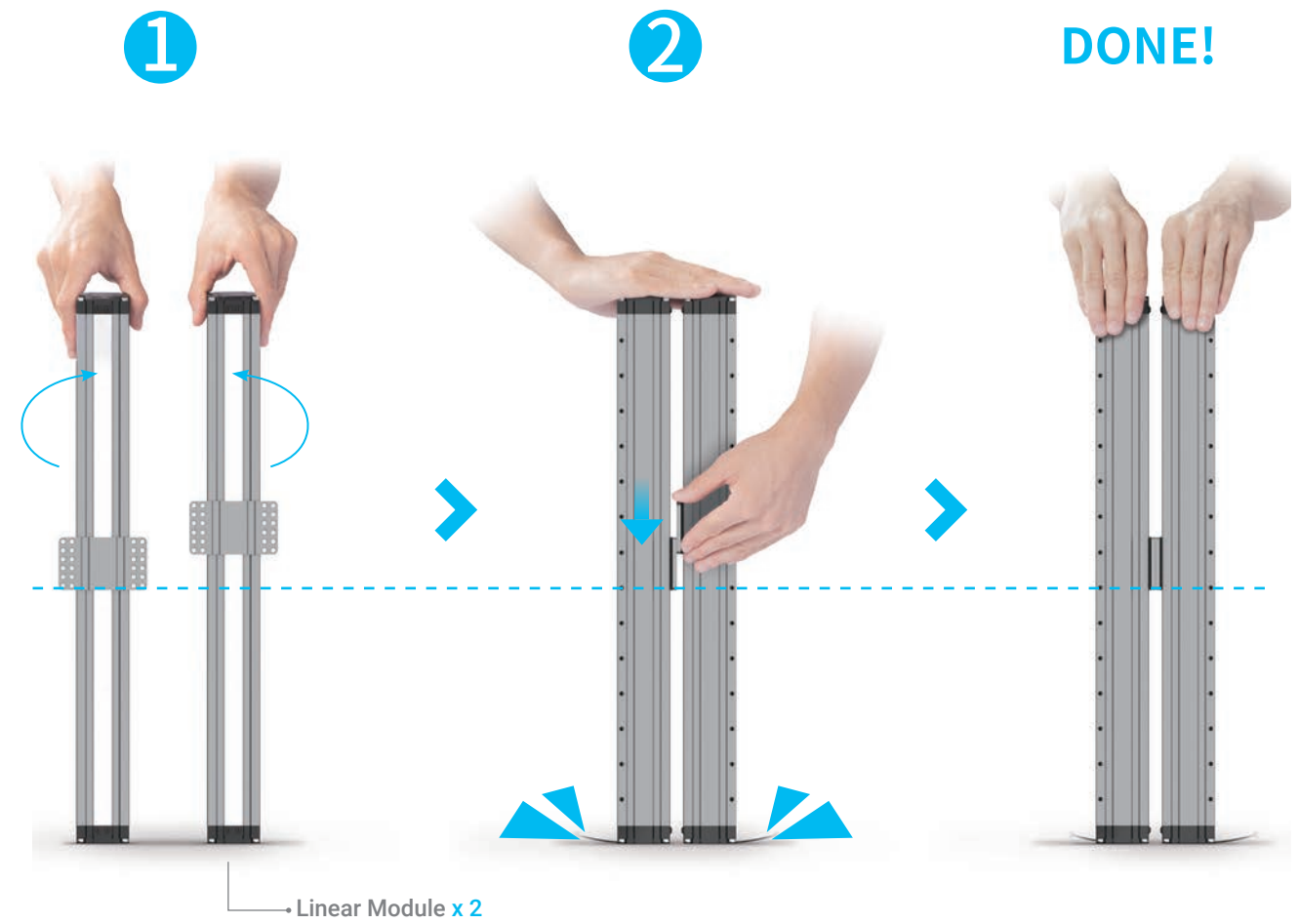

03/22

Attach the Platform to the Y axes. Do not tighten the screws until Step 5.

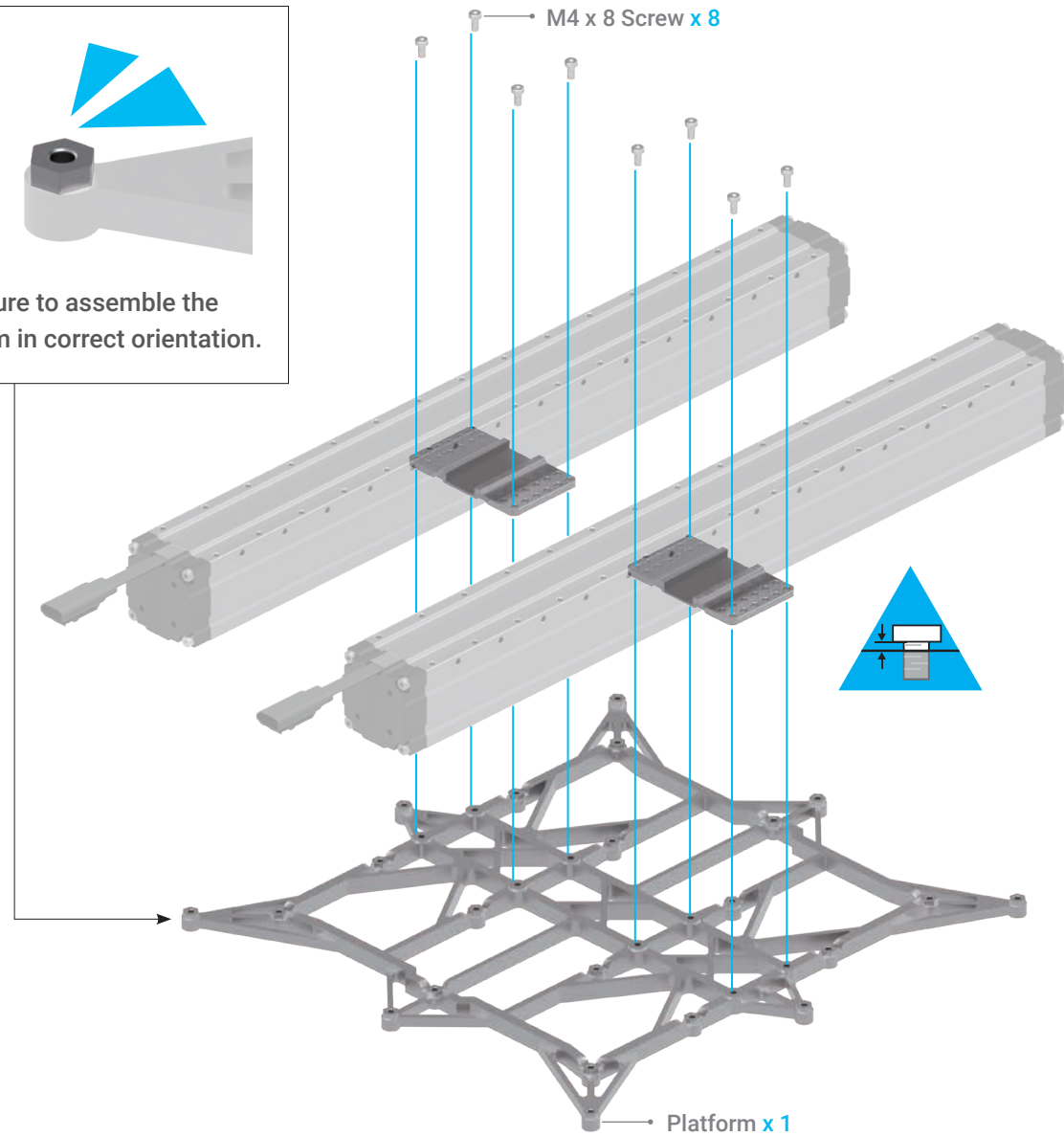
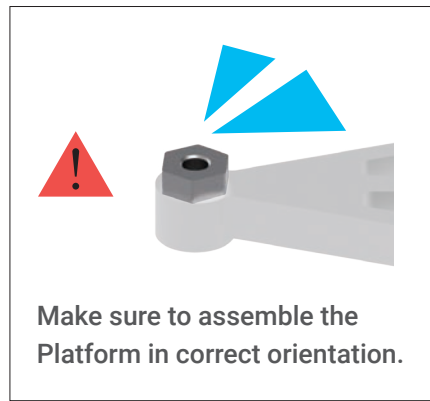
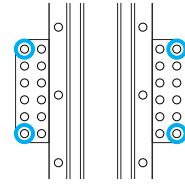
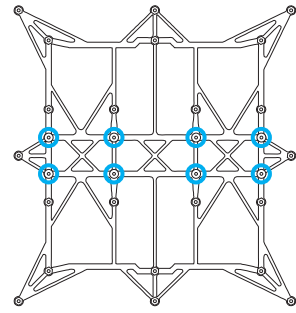

04/22

Attach the Y axes to the Base Plate.

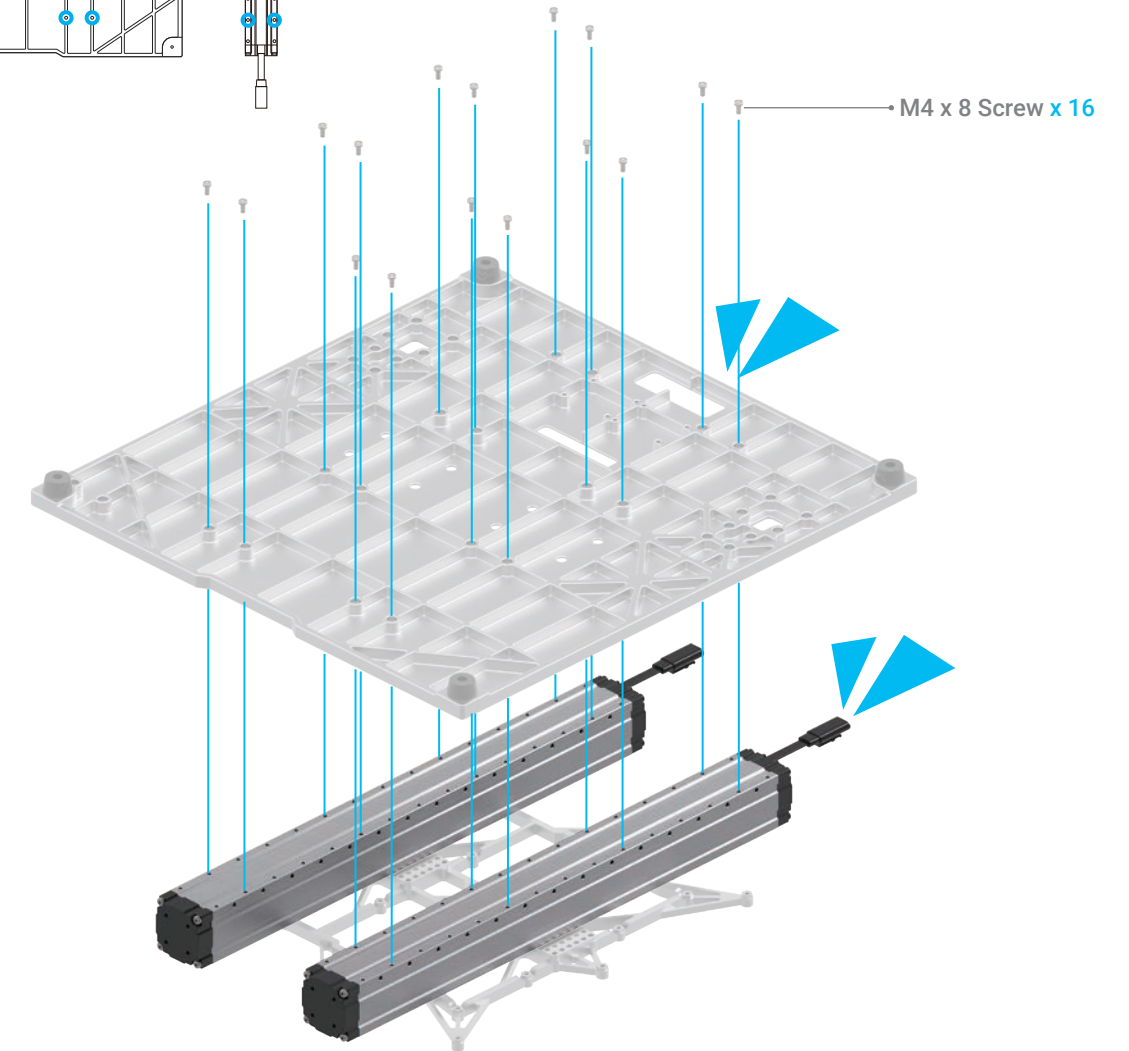
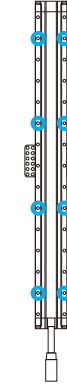
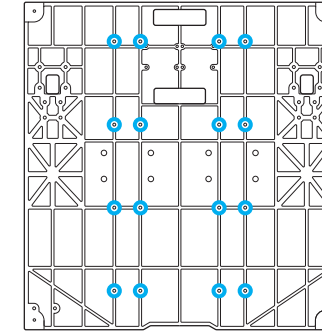

05/22

Tighten the screws on the Y-axis sliders.

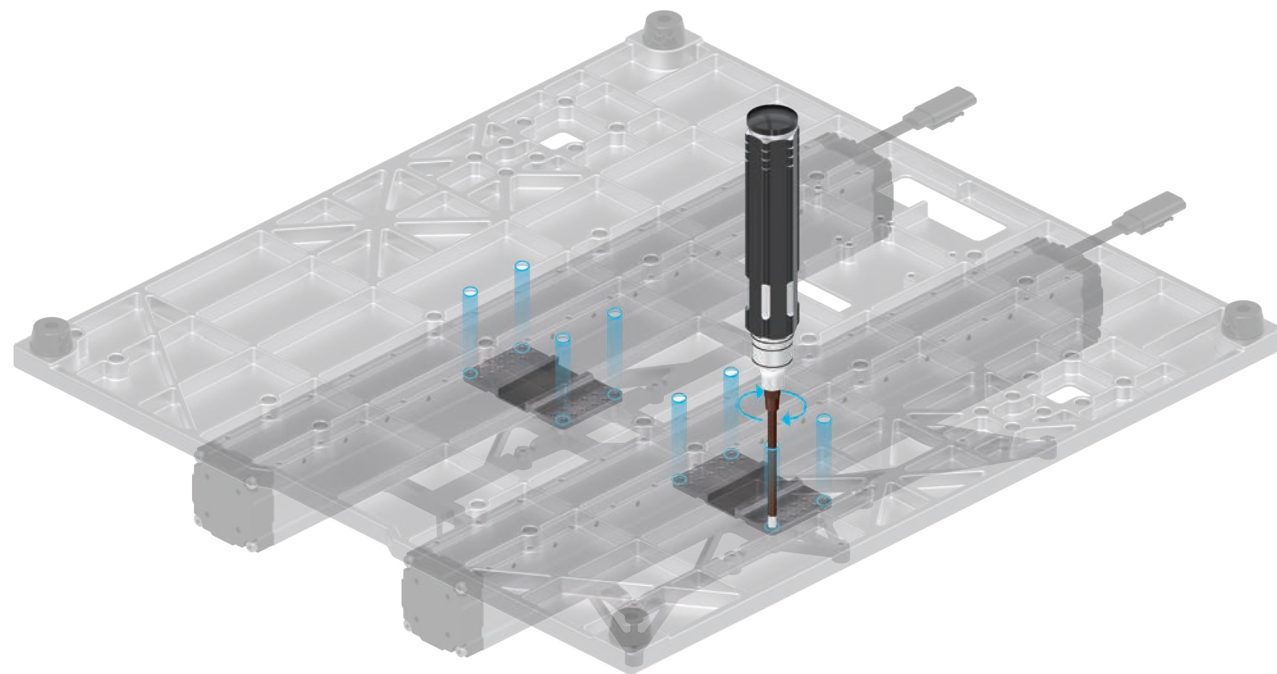
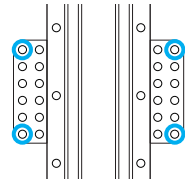
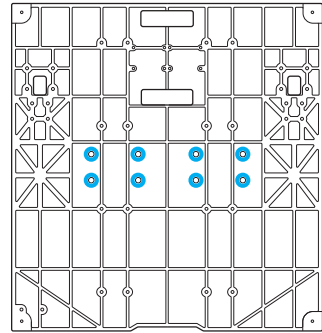

06/22

Attach the Z-Axis Holders to the Base Plate.

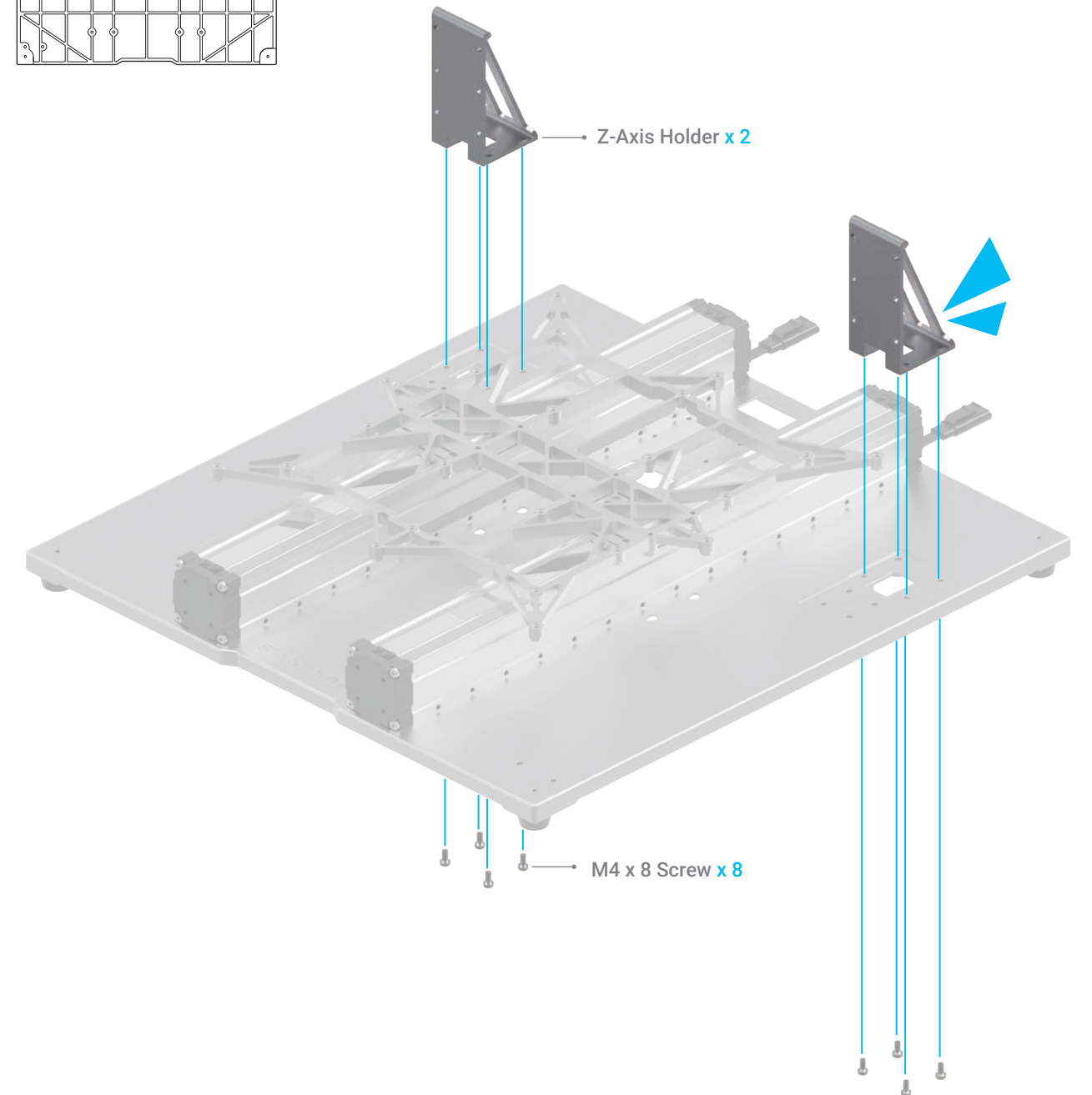
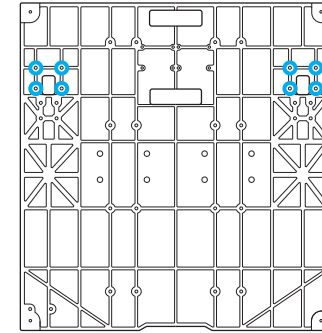

If the screws on the sliders are not aligning with the screw holes on the Base Plate, please move the Platform to the proper position.

07/22

Attach the Touchscreen Holder to the Base Plate.

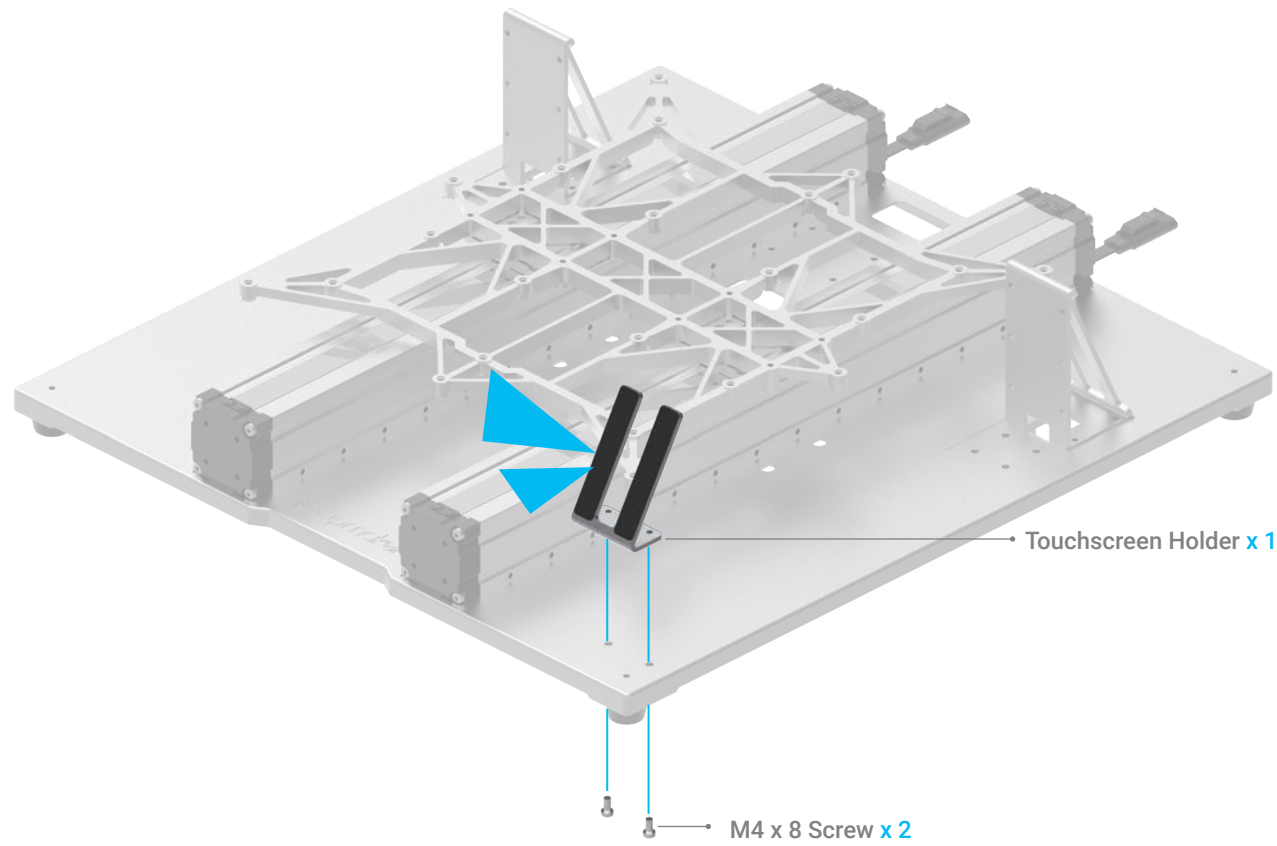
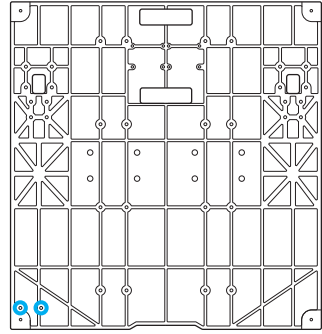

08/22

Thread the connecting cables through the holes of the holders, then attach the Z axes to the Z-Axis Holders. Do not tighten the screws until Step 12.

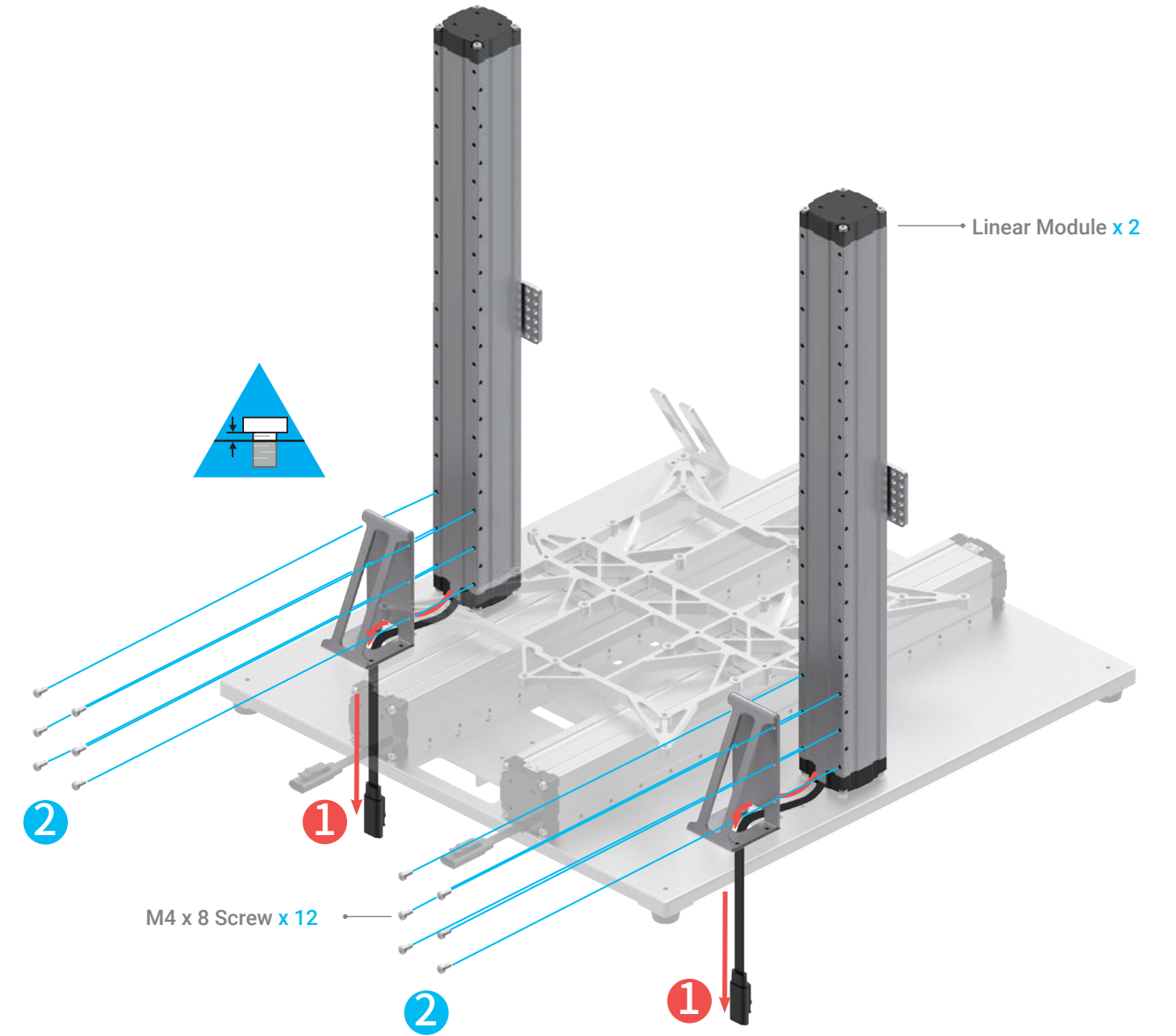
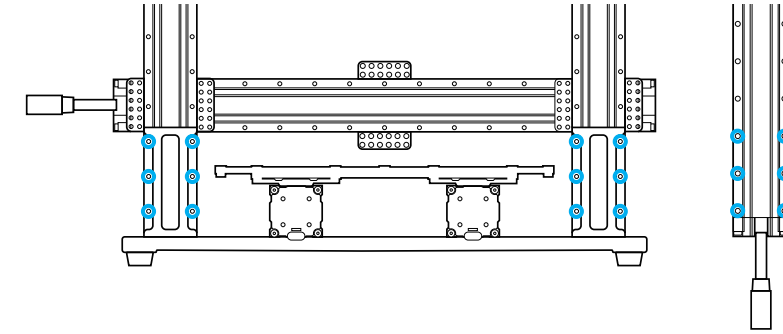

09/22

Install the screws to the bottom of the Z axes. Do not tighten the screws until Step 13.

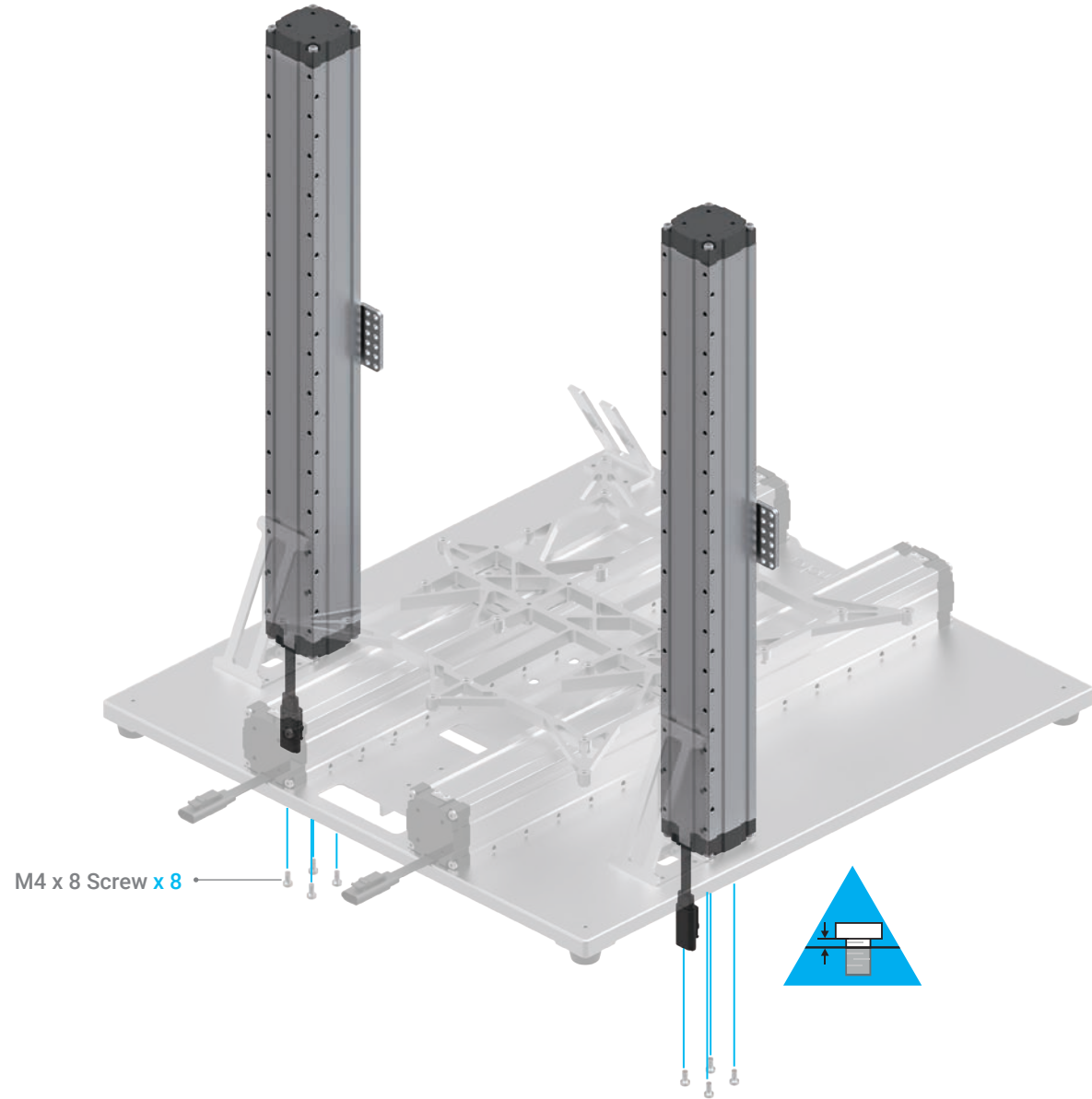
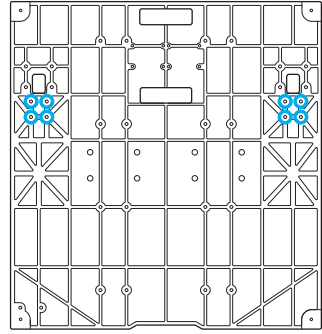

10/22

In the midline direction, manually move the Platform to the position as illustrated. Then move the Z-axis sliders to the lowest position that they can reach.

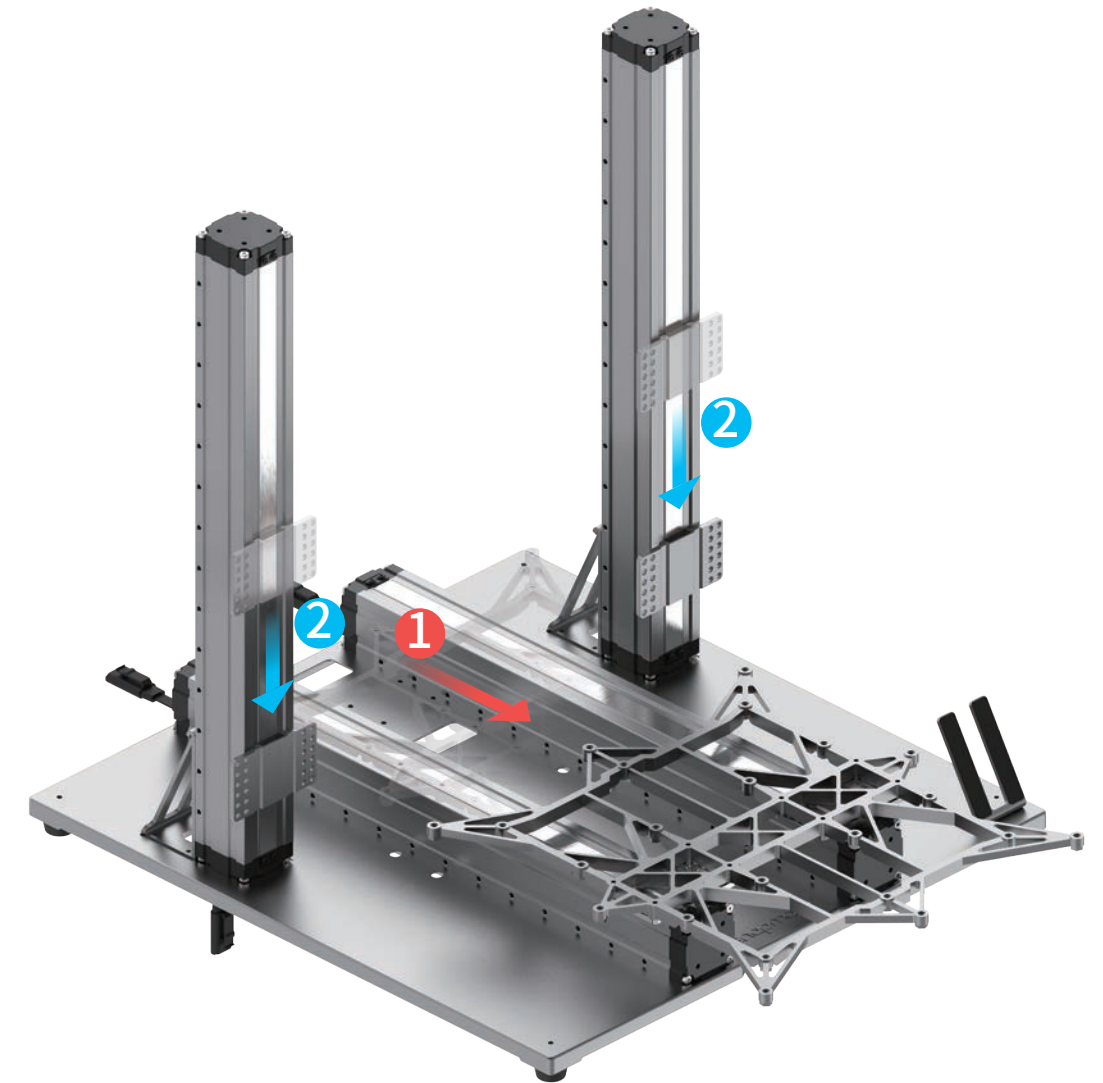
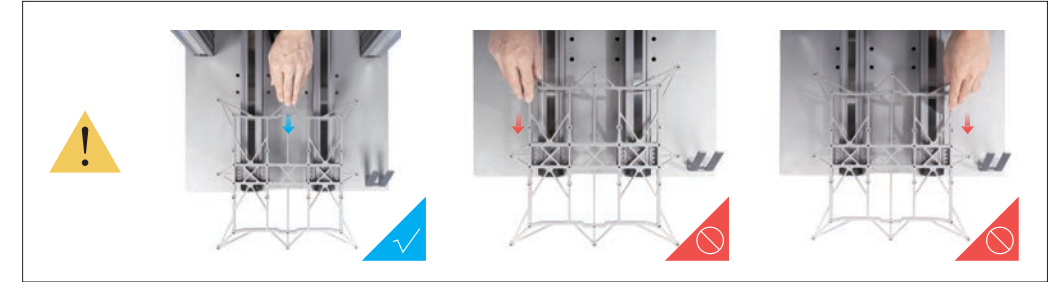

11/22

Attach the X axis to the sliders on the Z axes.

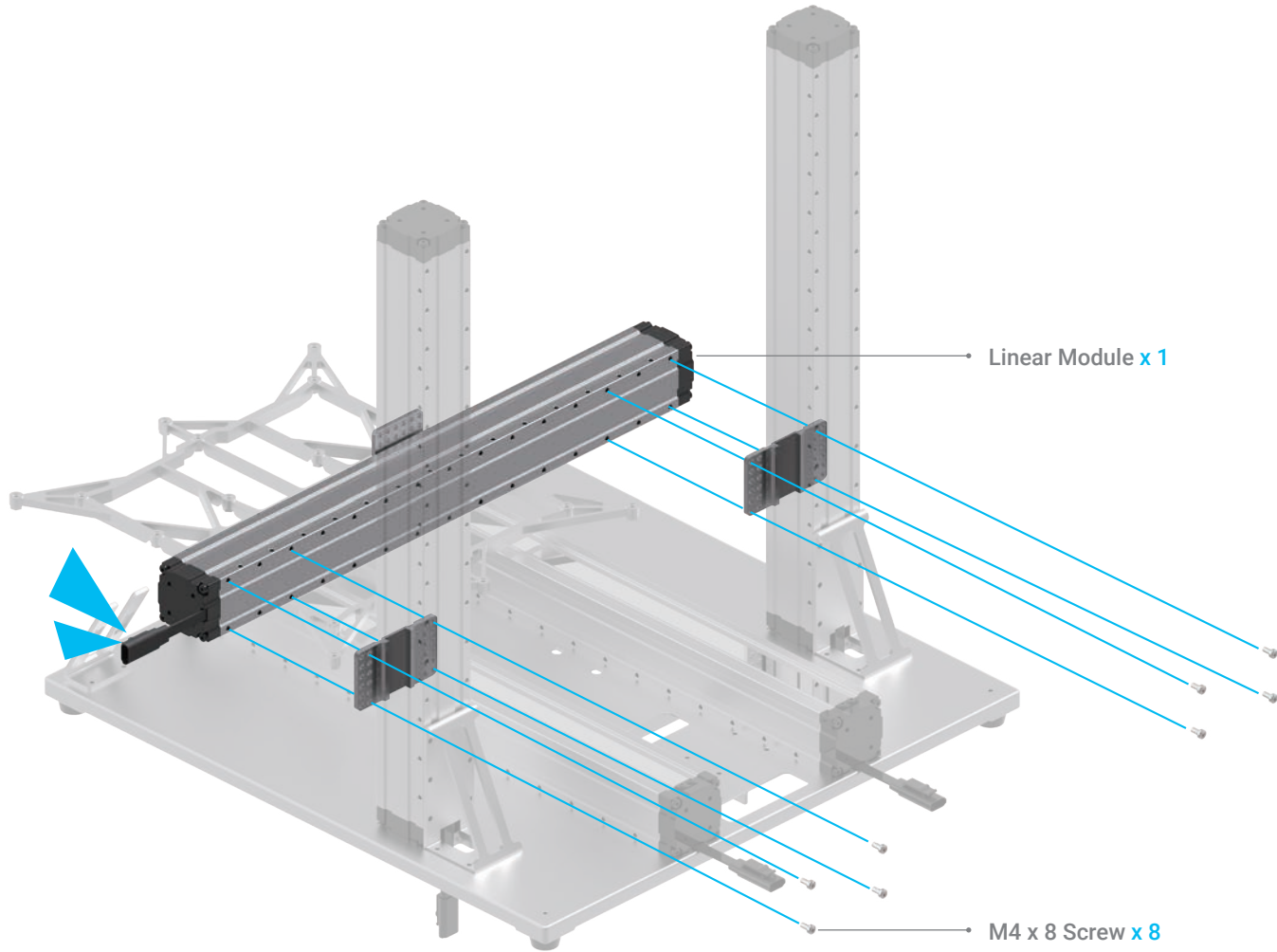
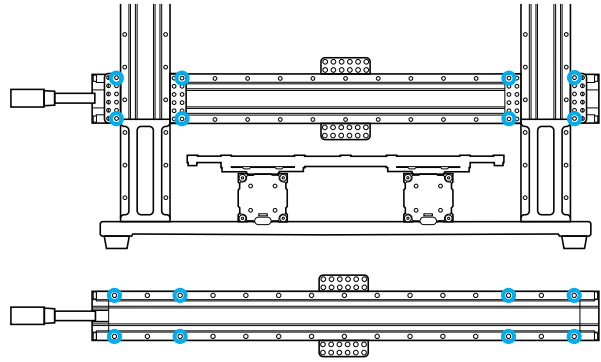

12/22

Tighten the screws that are used to attach the Z axes to the Z-Axis Holders.

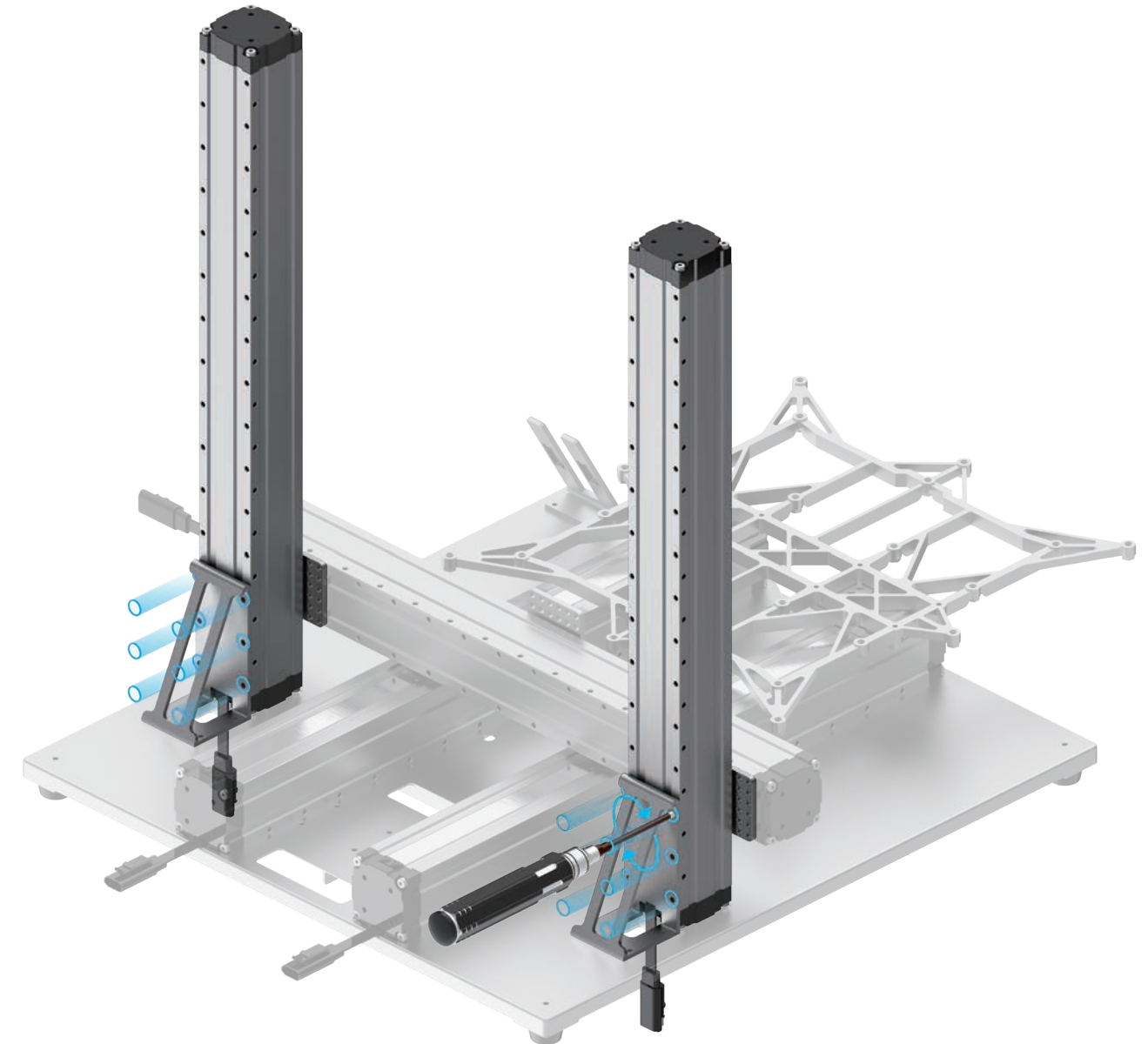
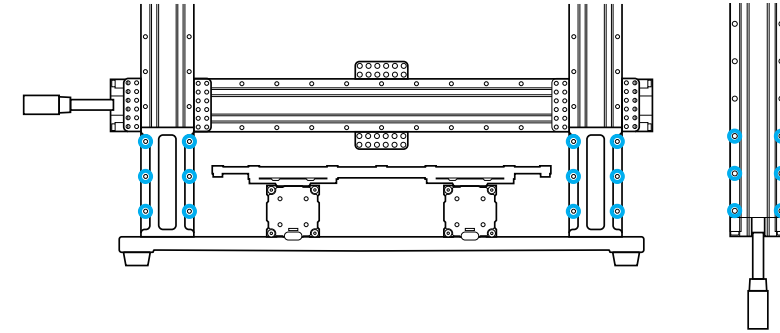

13/22

Tighten the screws to the bottom of the Z axes.

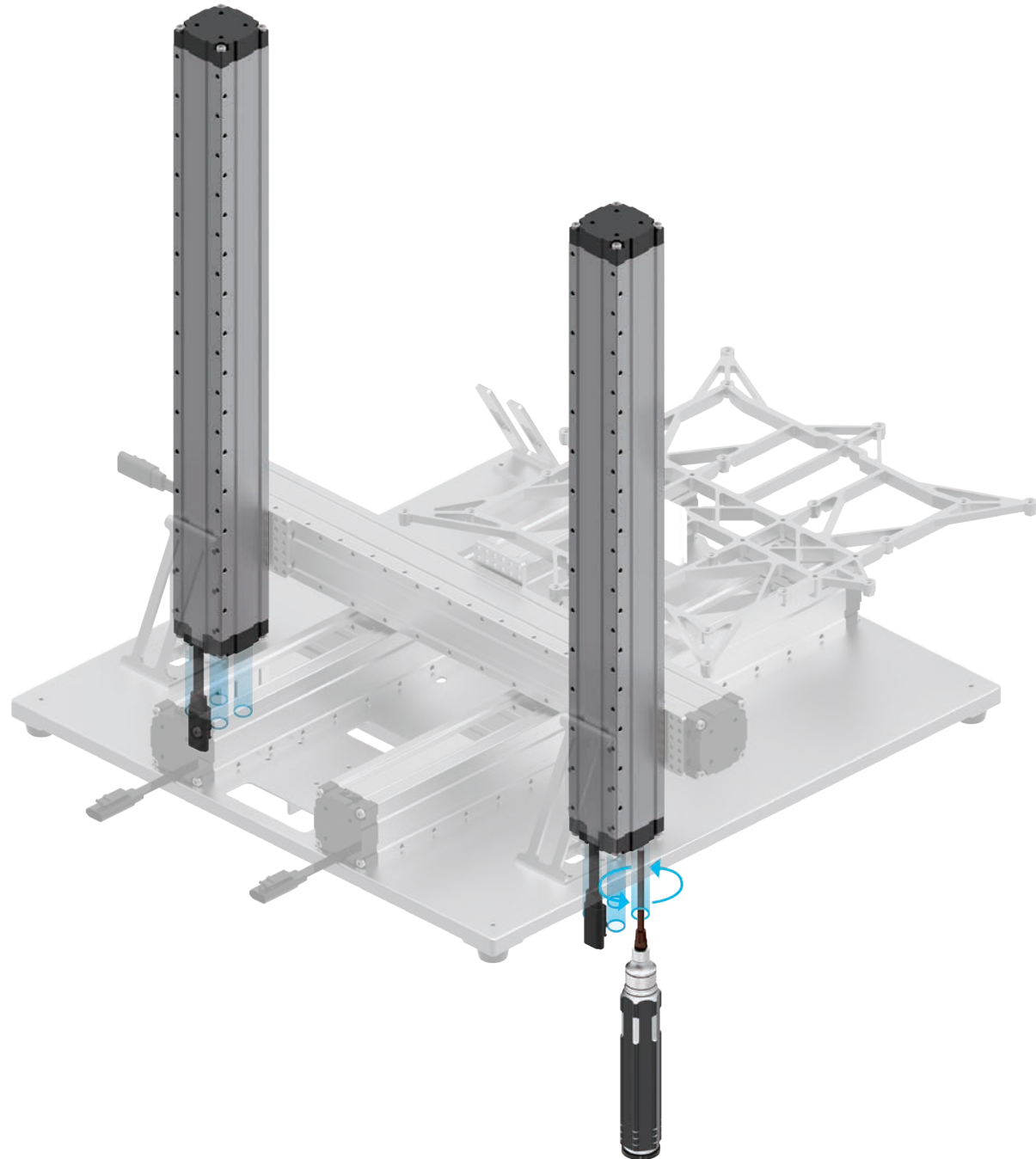
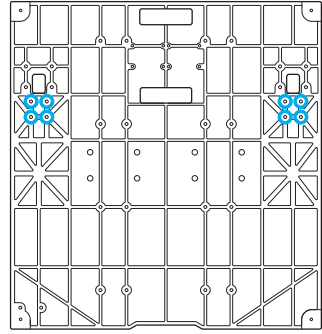

14/22

Put your hands at each end of the linear module, then move the X axis to the top.



Make sure both ends of the linear module are in horizontal alignment with each other throughout the process.

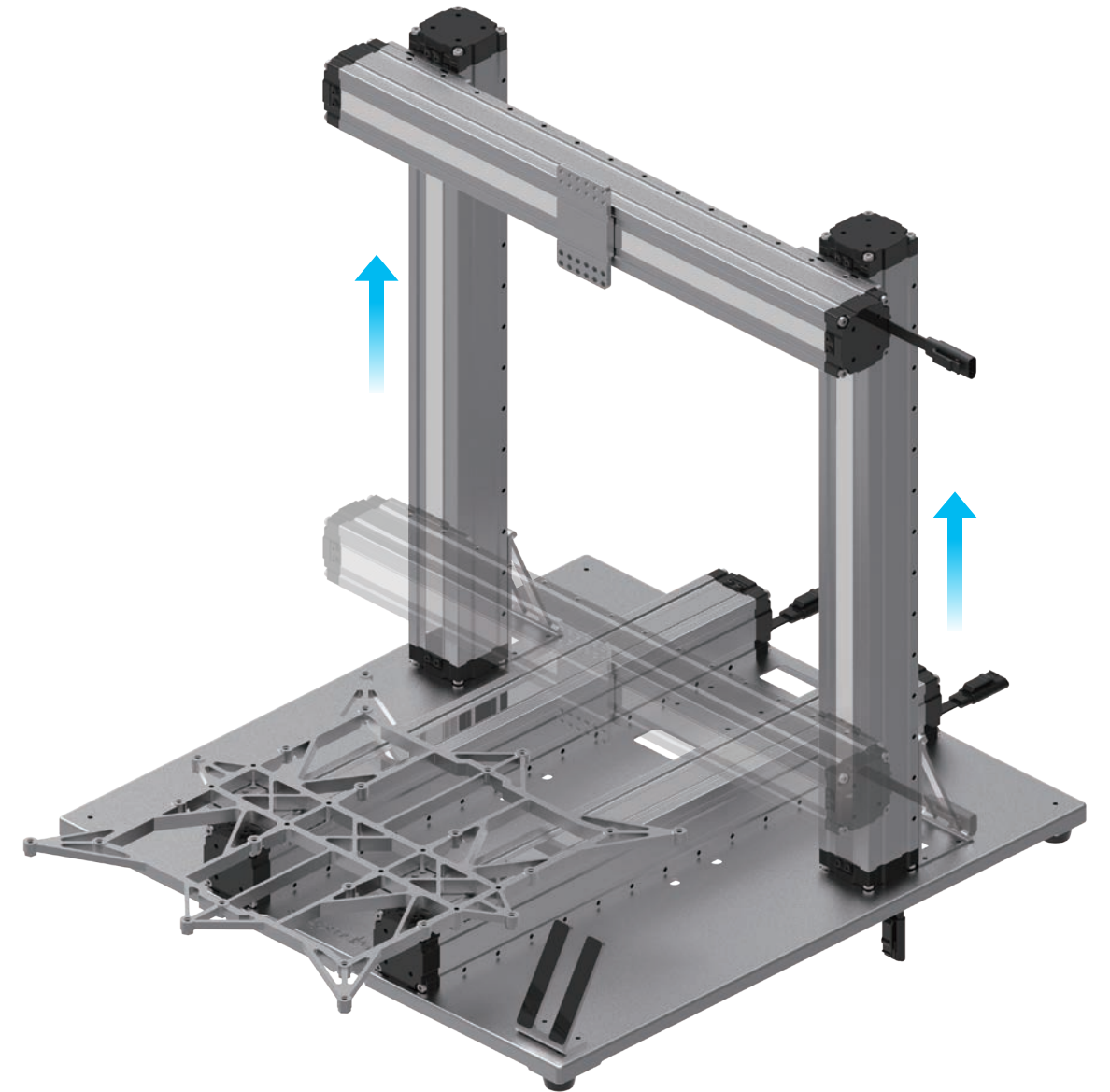

15/22

Locate the Y Conversion Cable and the Y-axis connecting cables as illustrated, then connect them to the Converter.

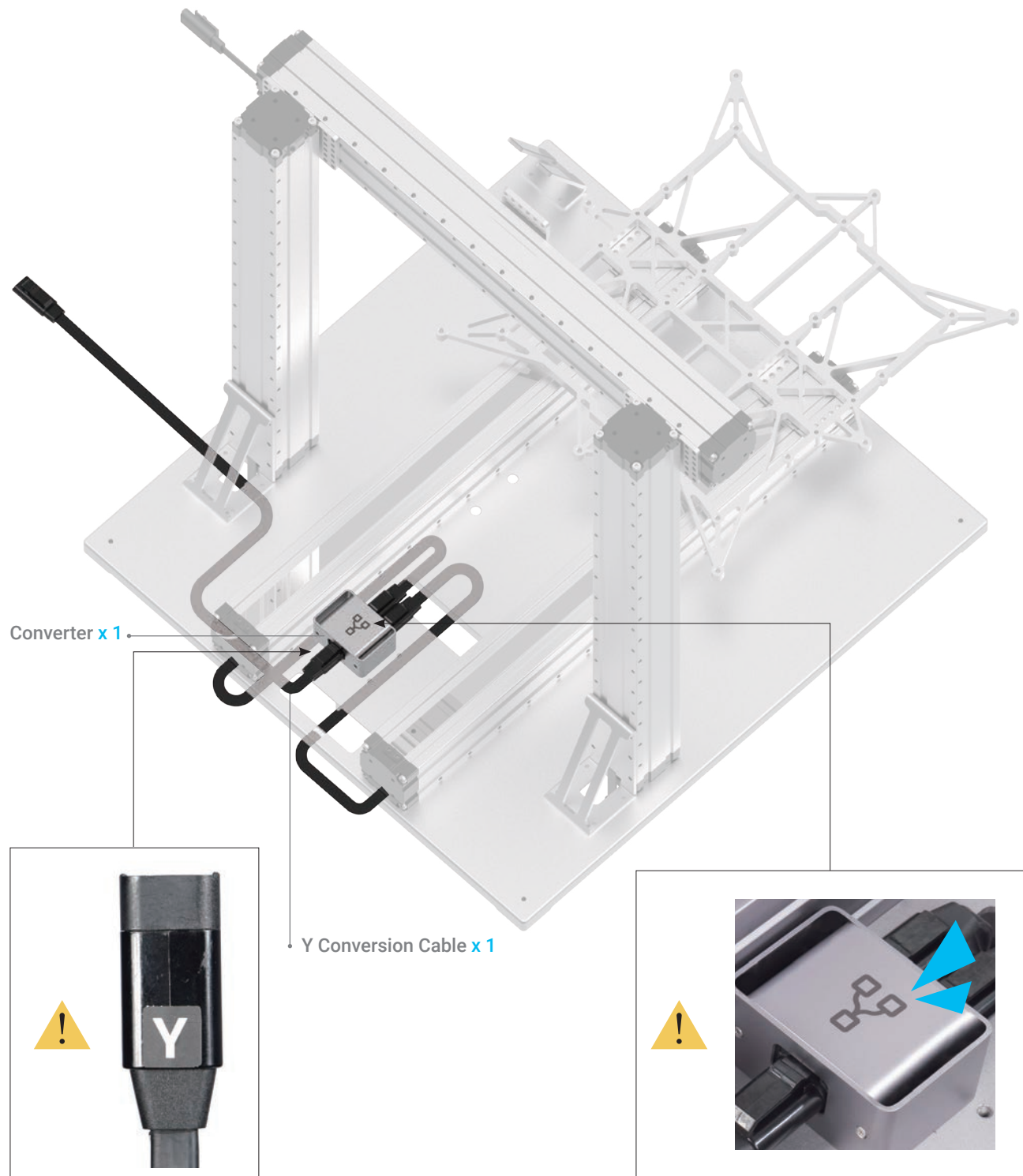

16/22

Attach the Y-axis converter to the Base Plate.

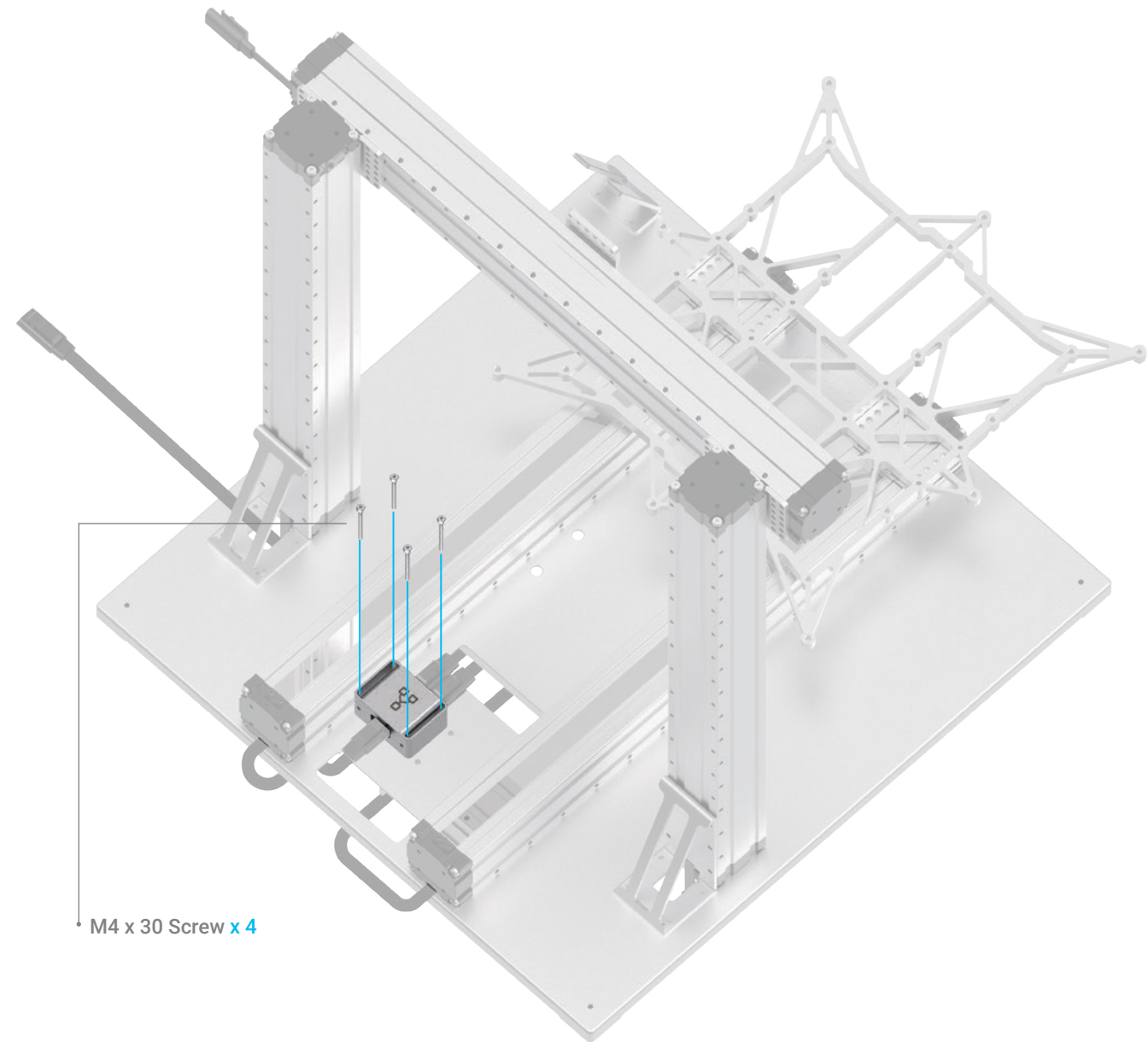
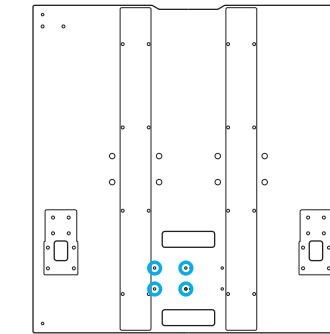

17/22

Locate the Z Conversion Cable and the Z-axis connecting cables as illustrated, then connect them to the Converter.

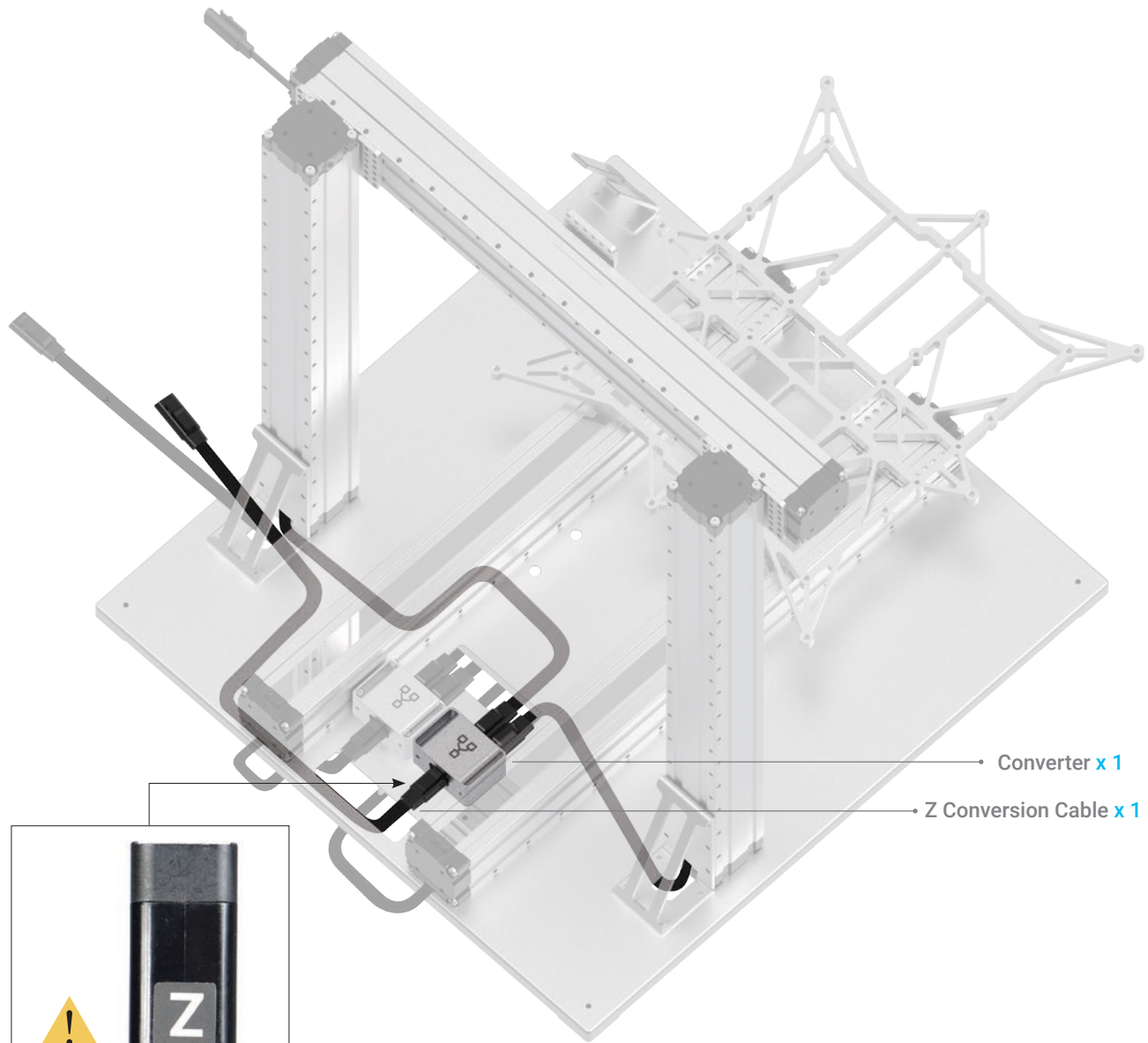

18/22

Attach the Z-axis converter to the Base Plate.

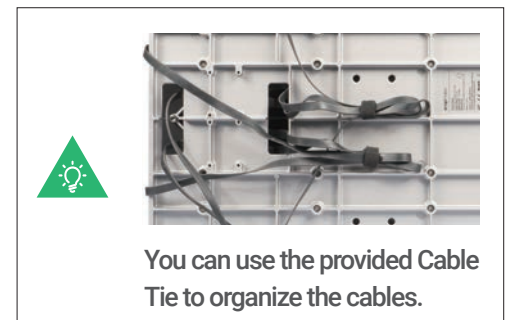
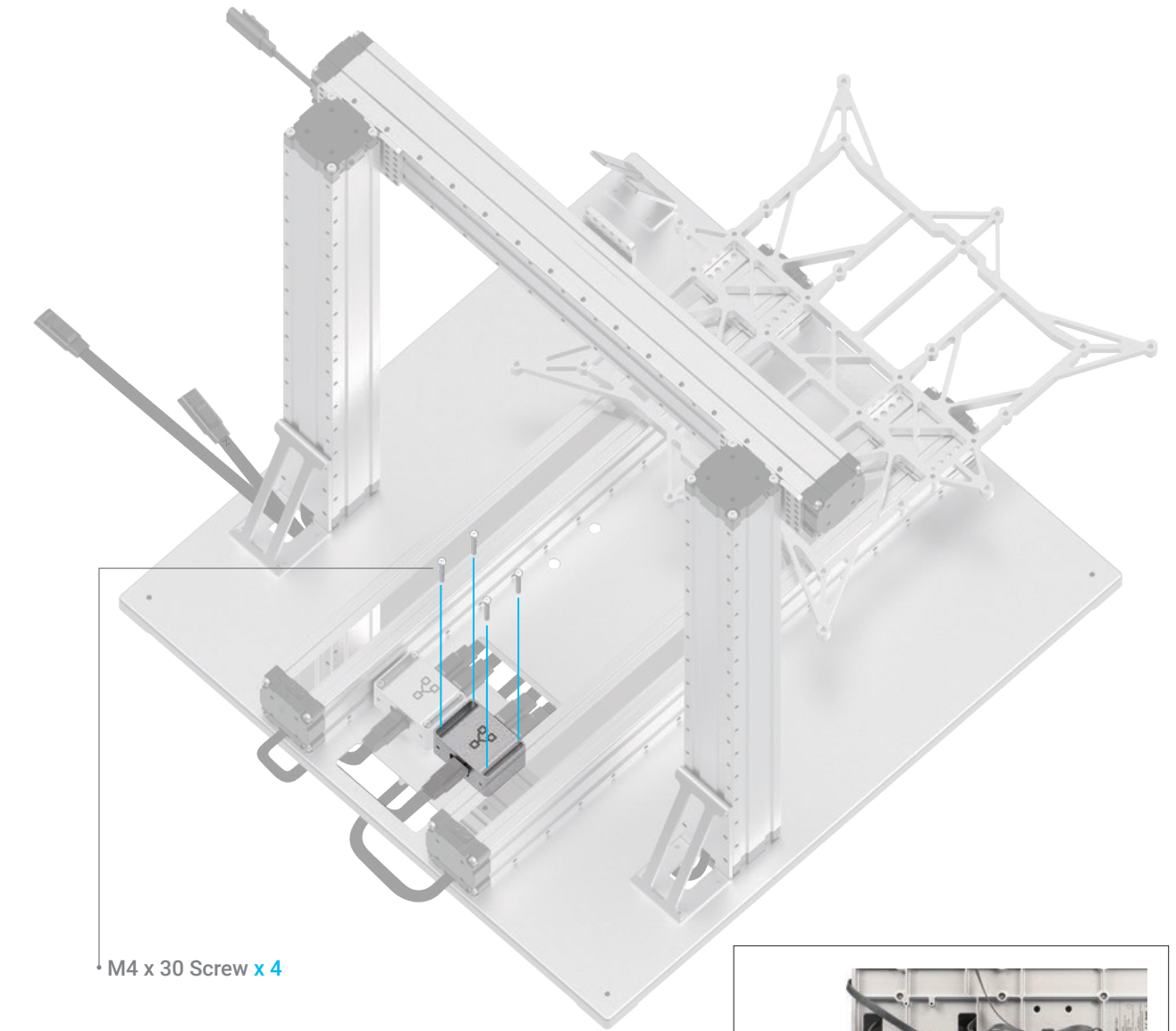
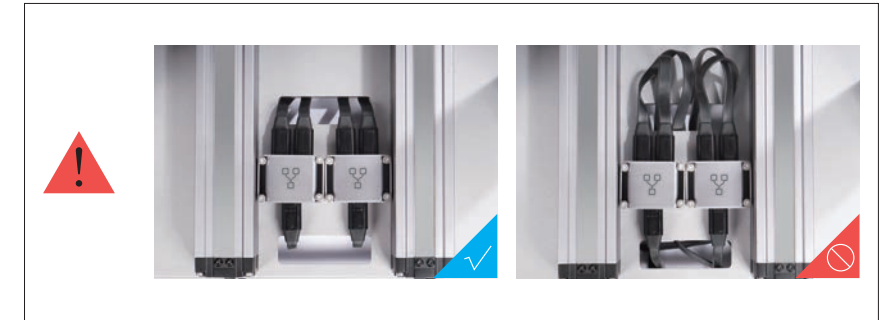
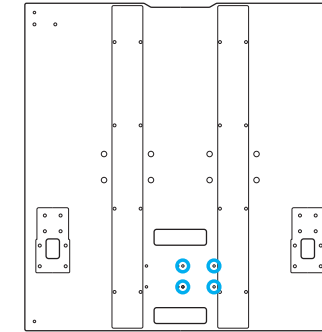

19/22

Attach the Controller to the Z axis.

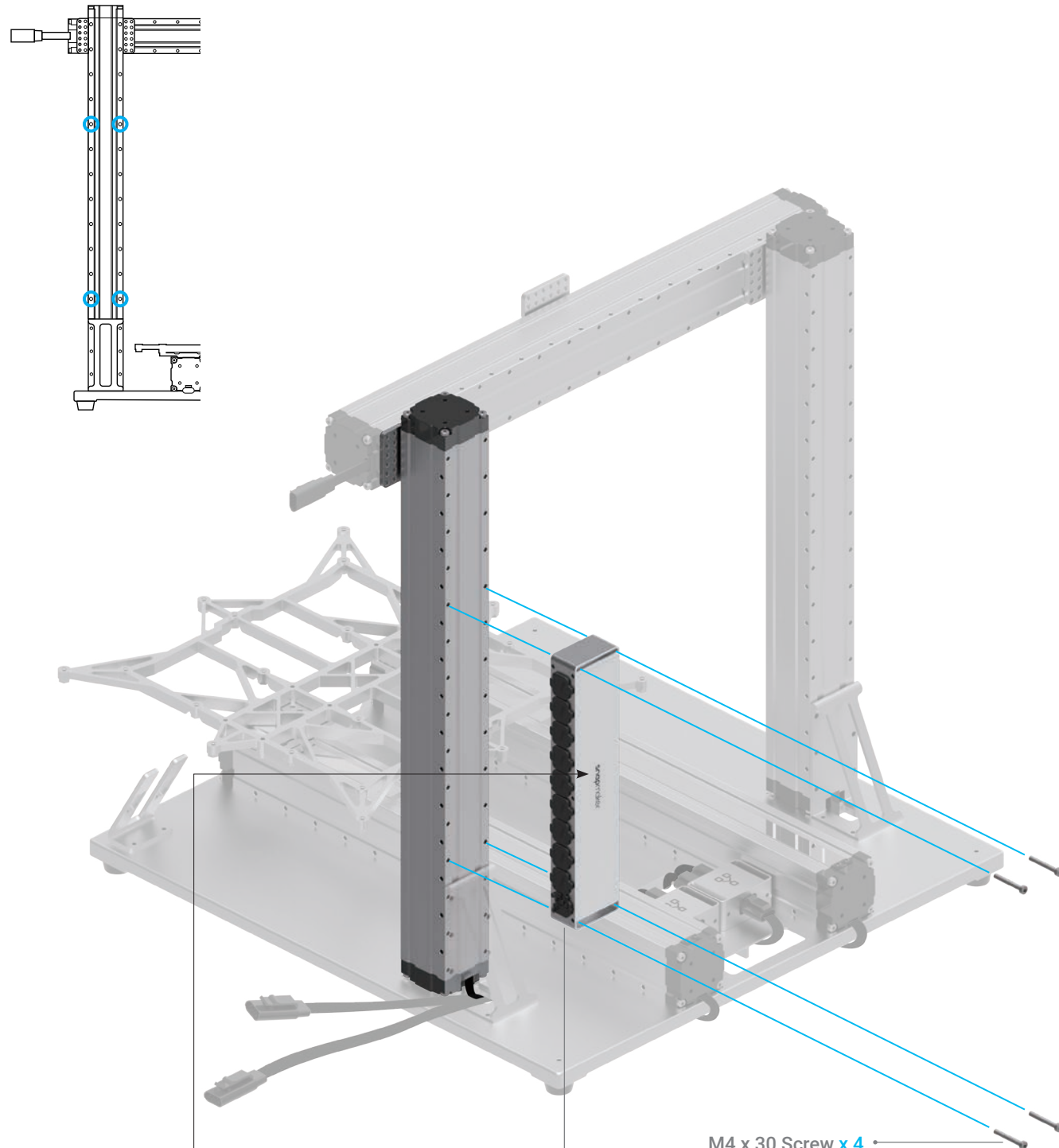

M4 x 30 Screw x 4

Controller x 1

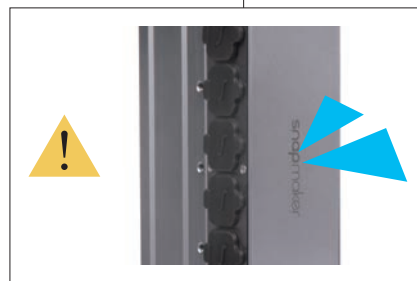

20/22

Open the dust plugs, then connect the X, Y and Z axis to the Controller.

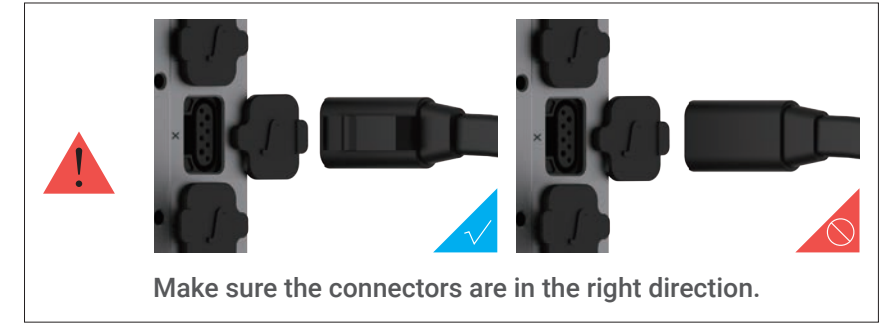
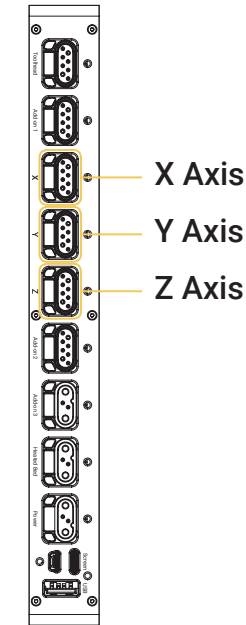

Make sure the connectors are in the right direction.

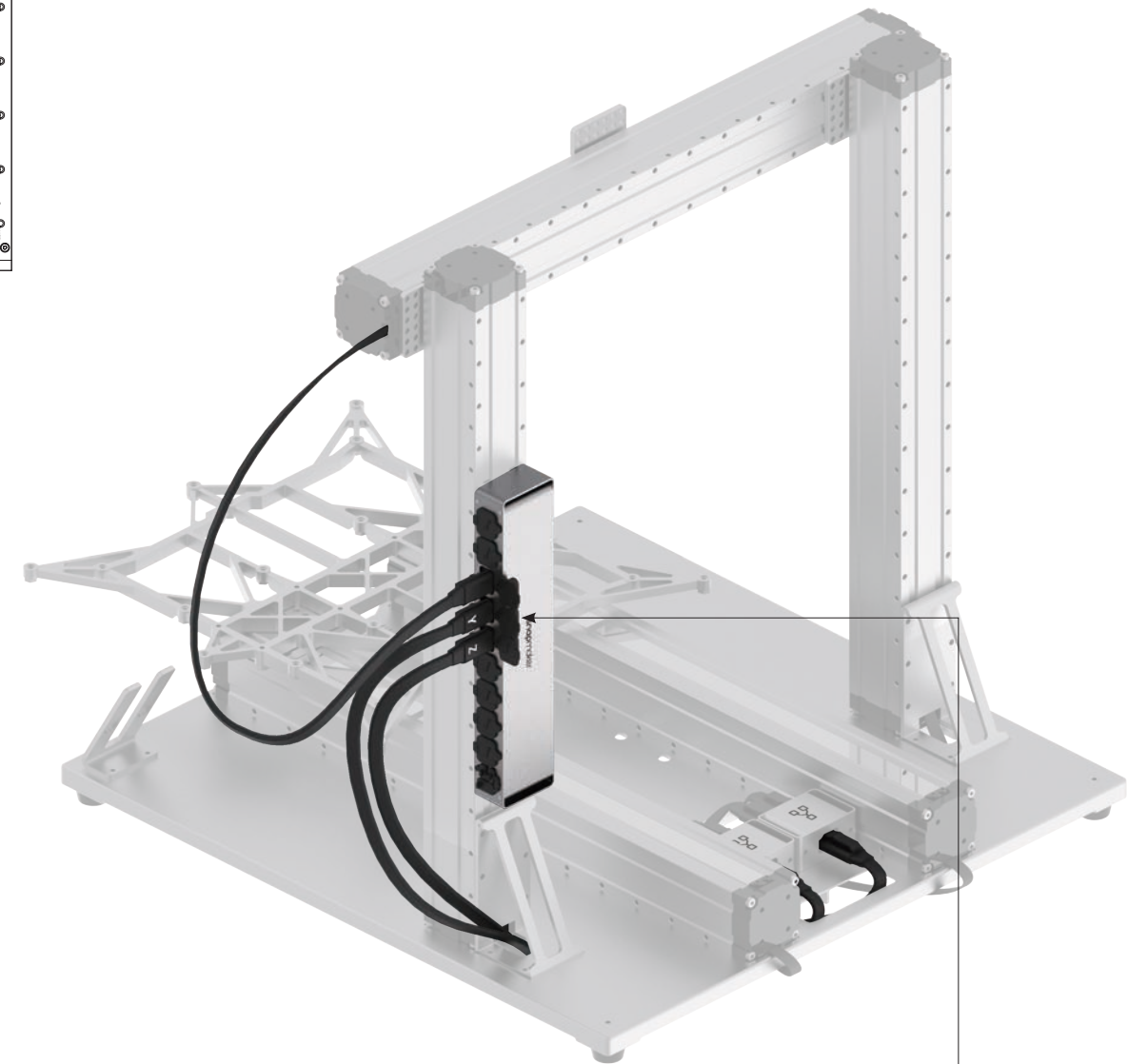

Keep the protective dust plugs on the unplugged connectors. Dust accumulation may seriously affect the performance of the Controller.



21/22

Place the Touchscreen, then connect the Touchscreen to the Controller.

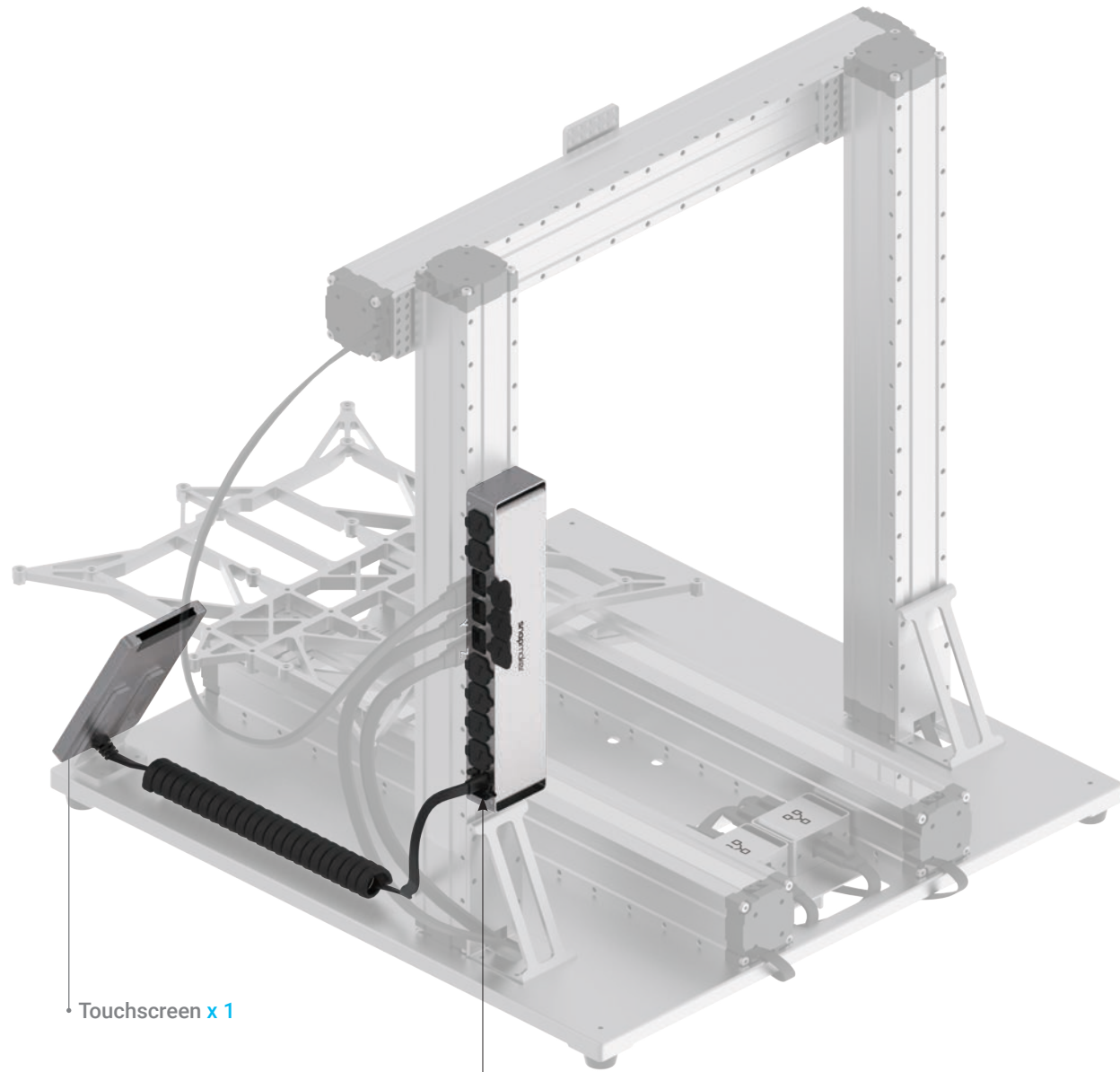

22/22

Connect the cables for the Power Module.

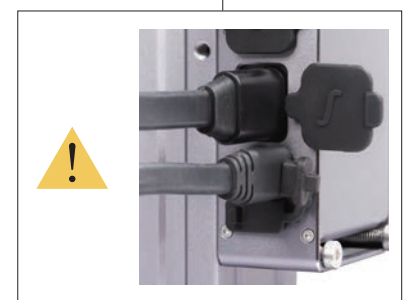
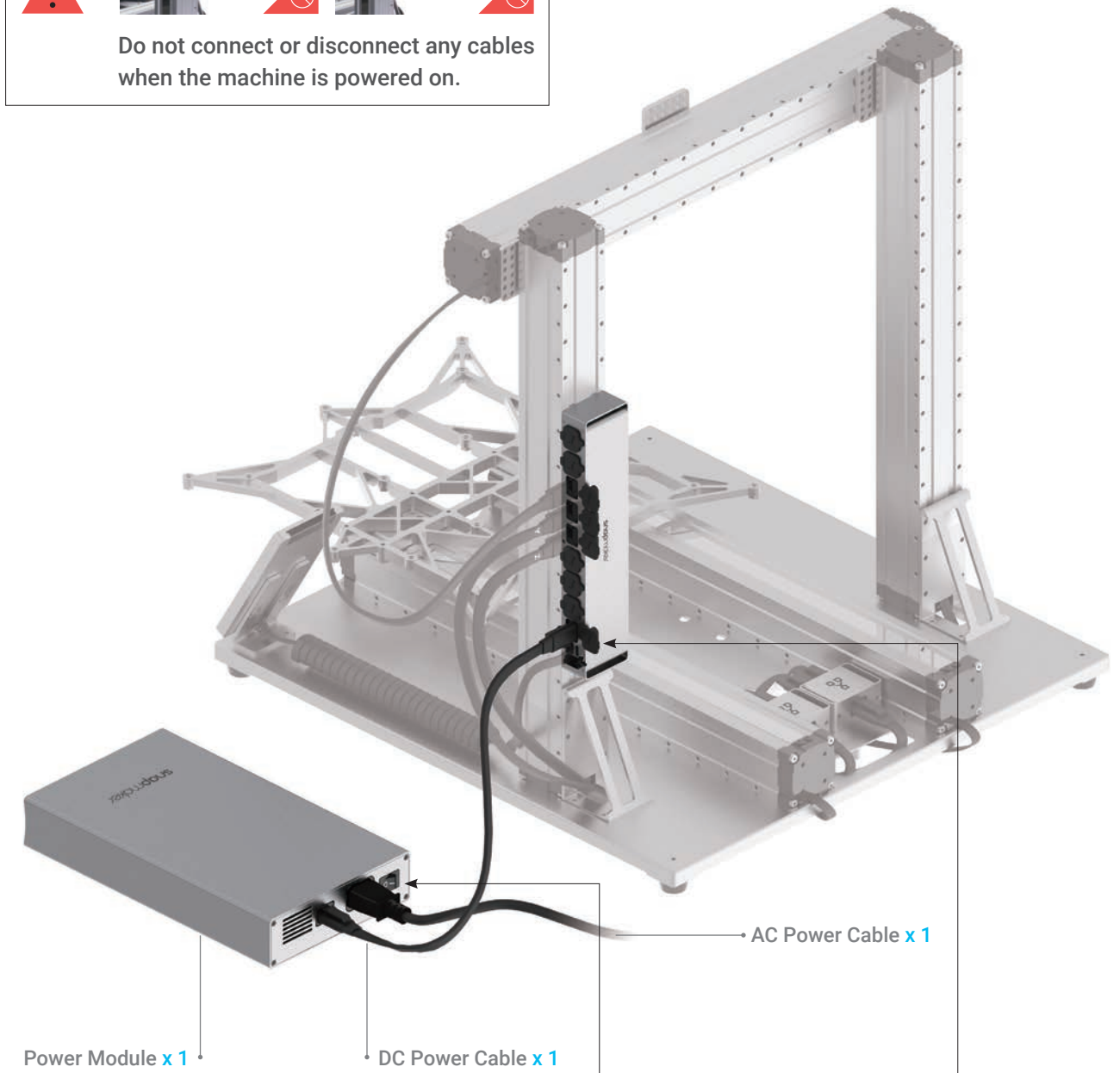
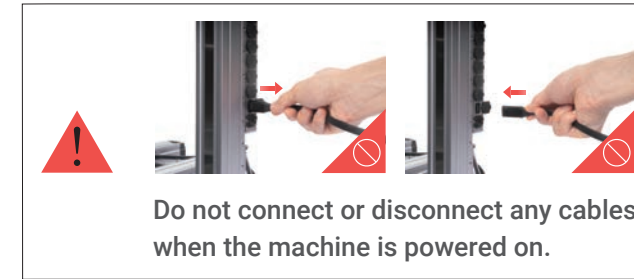

Absolutely amazing!
You have successfully assembled the machine body, just select one function to complete the assembly and bring your first job into the world!

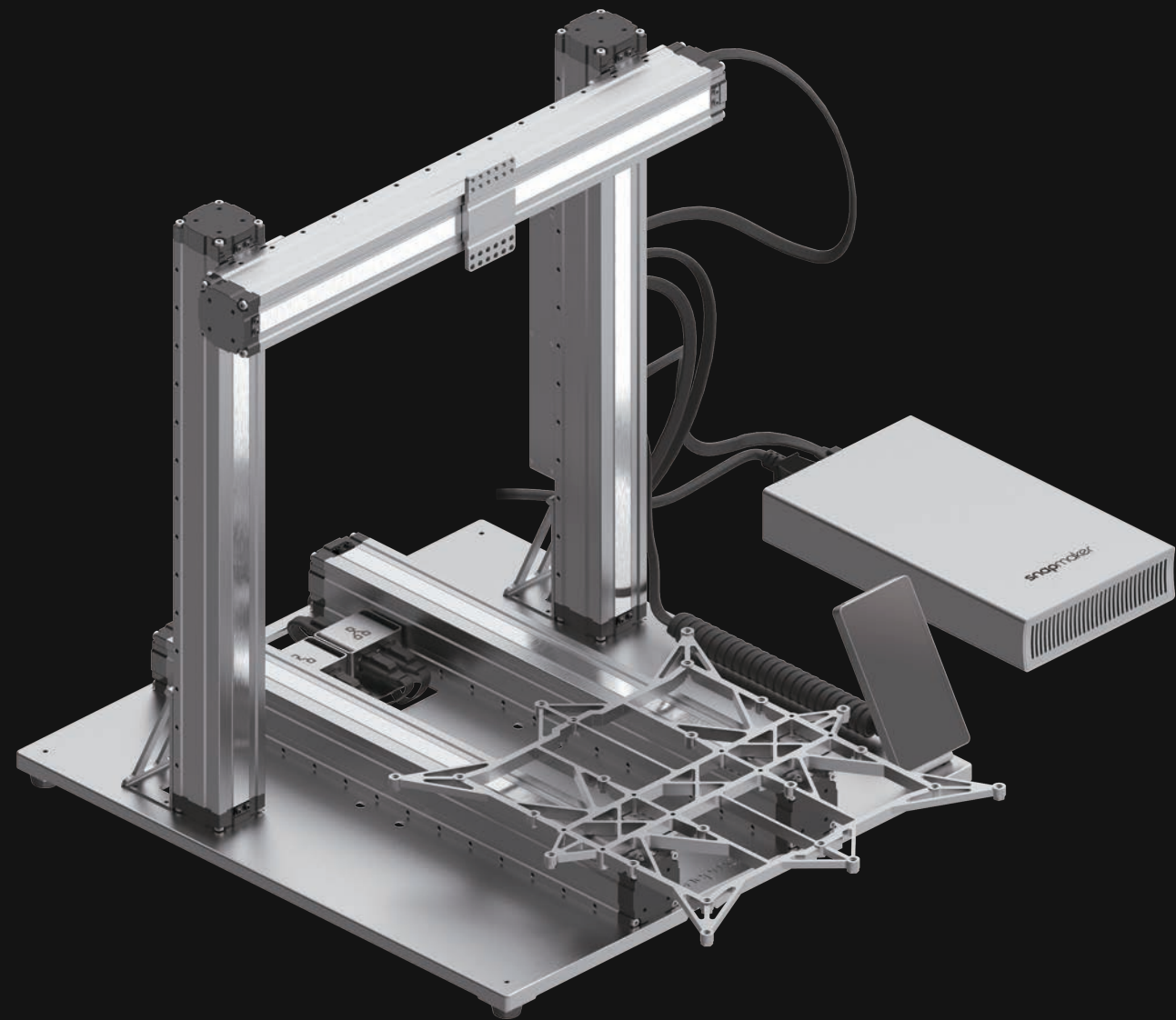

+



3D Printing



PAGE 38

+



**Laser Engraving
and Cutting**



PAGE 56

+



CNC Carving



PAGE 72



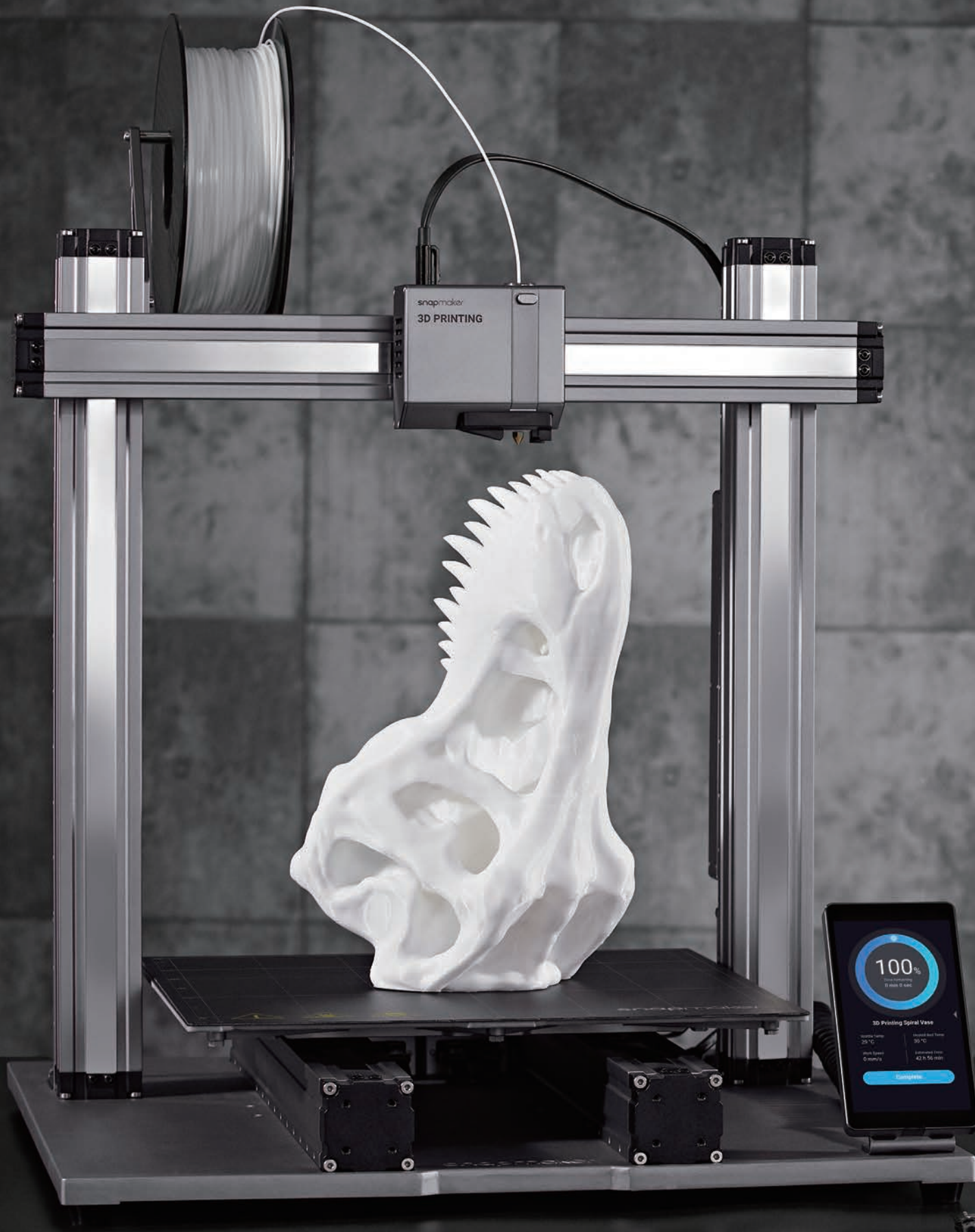

3D Printing

3.1 Assembly

- 3.1.1 Assemble the 3D Printer
- 3.1.2 Initial Setup

3.2 Get Started

- 3.2.1 Calibrate the Bed
- 3.2.2 Load Filament

3.3 Start Printing

- 3.3.1 Prepare the G-code File
- 3.3.2 Start Your First Print
- 3.3.3 Remove the Print

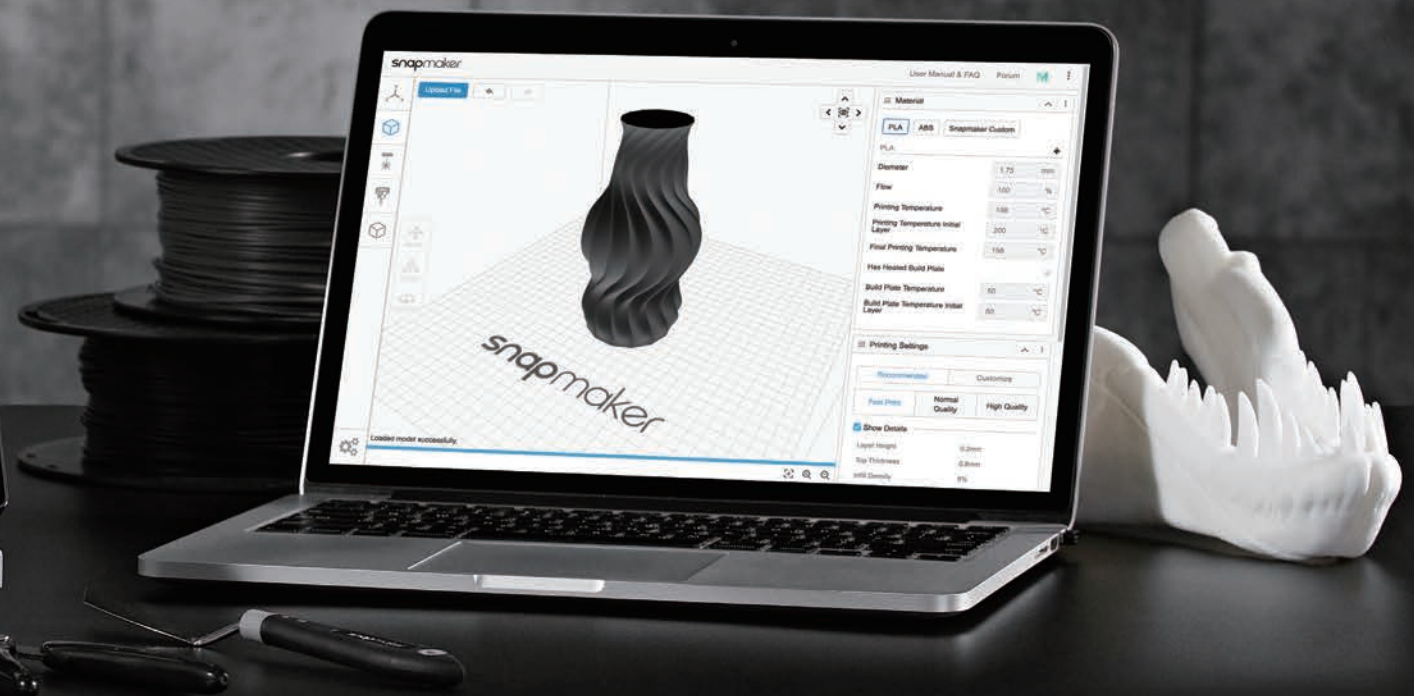

3.1.1 Assemble the 3D Printer

01/07

Attach the 3D Printing Module to the slider on the X axis.

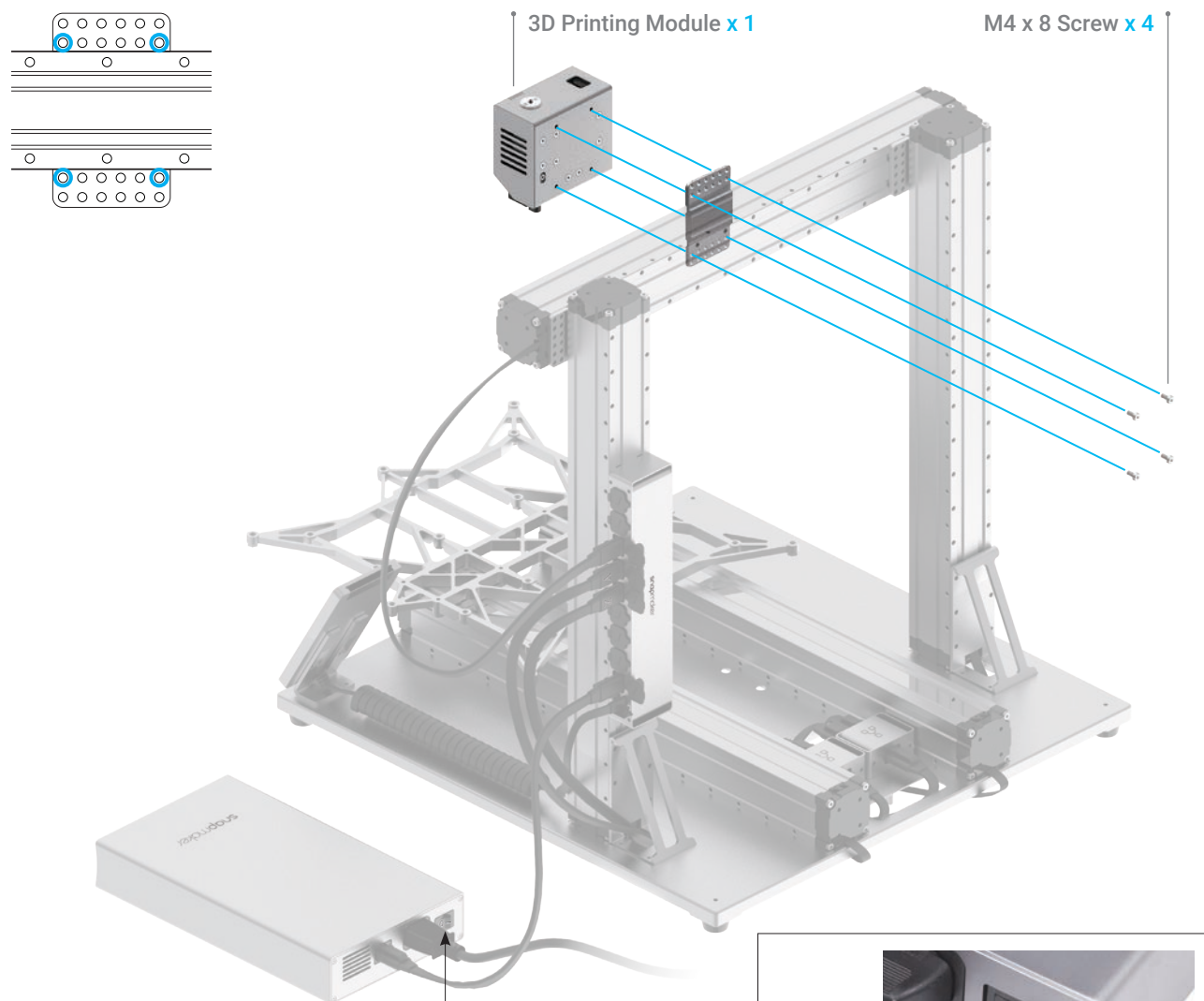

02/07

Connect the 3D Printing Module to the Controller.

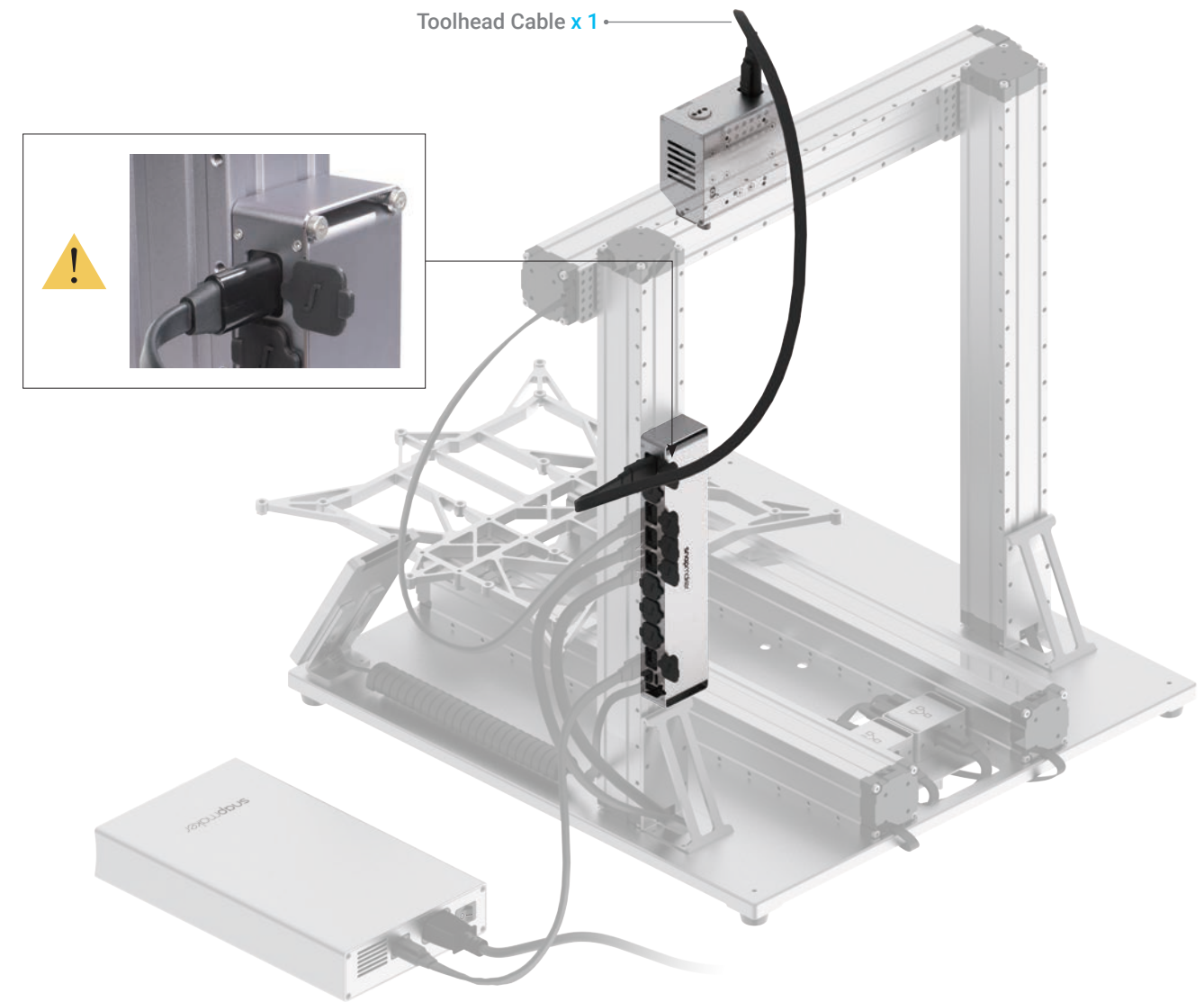

03/07

Attach the Filament Holder to the Z axis.

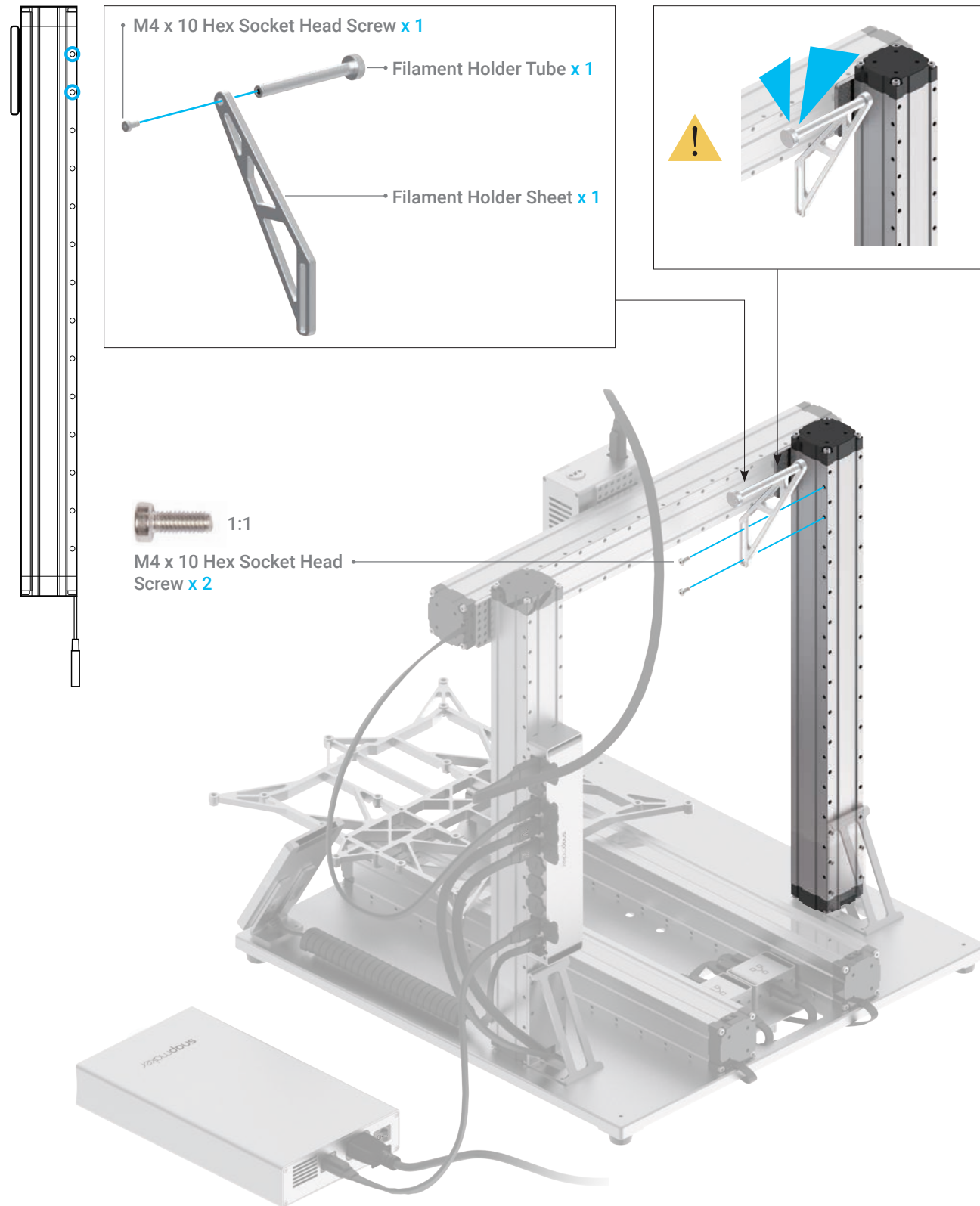

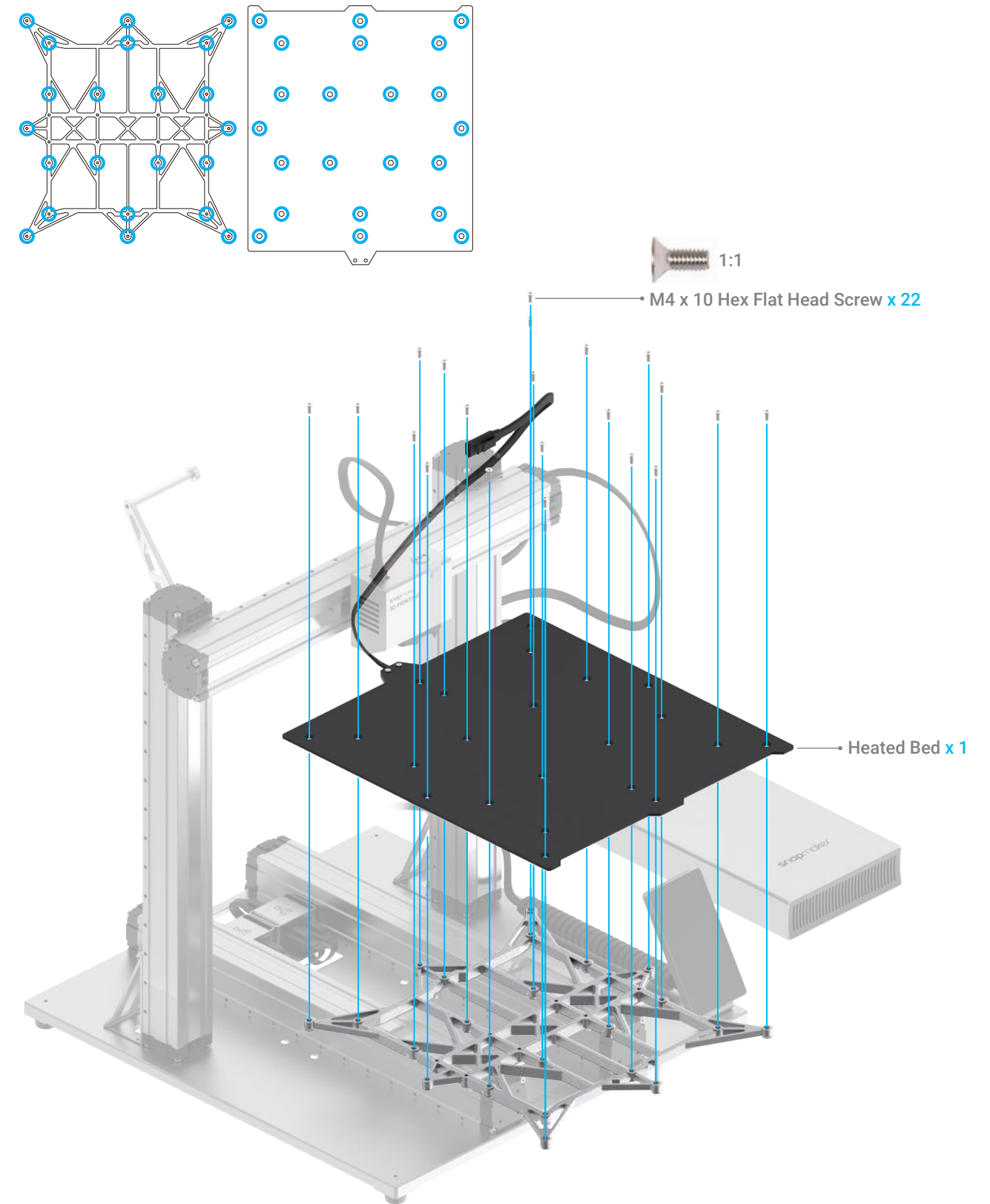

04/07

Attach the Heated Bed to the Platform.



05/07

Place the Print Sheet.

-  Make sure the Heated Bed is clean and there isn't any dust or dirt on it before you place the Print Sheet.
-  Make sure the Print Sheet aligns perfectly with the Heated Bed.

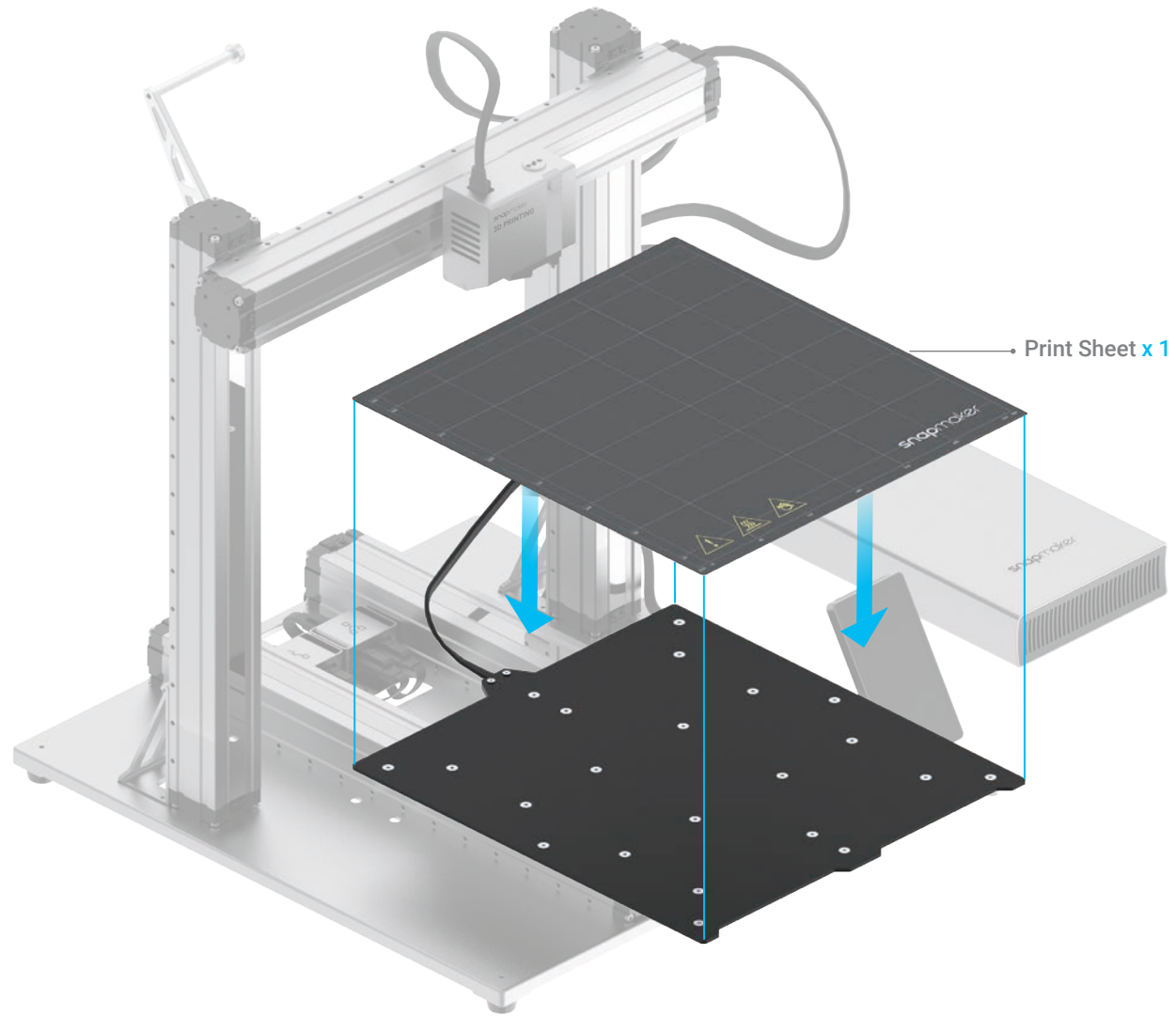

06/07

Connect the Heated Bed to the Controller.

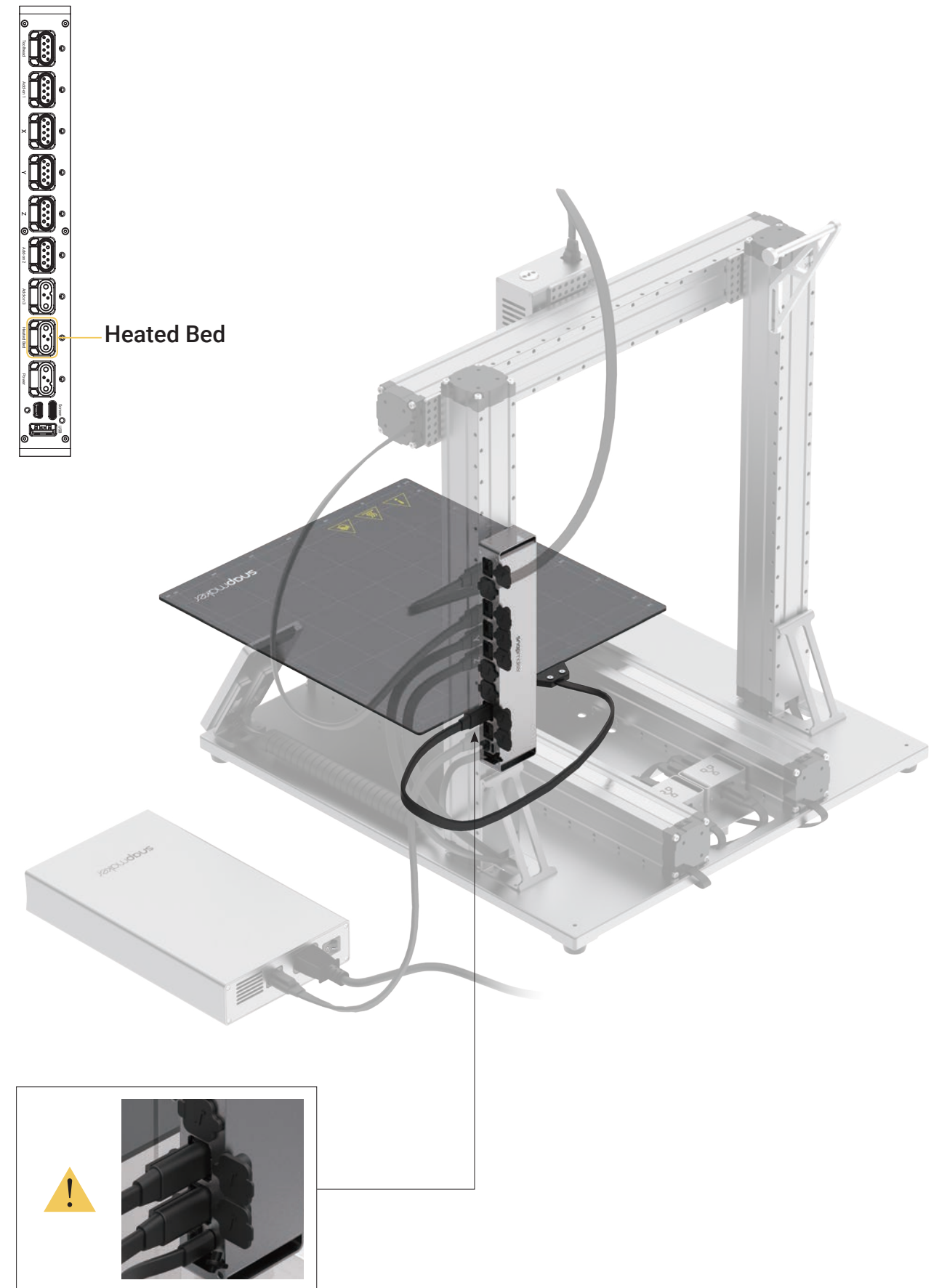

Attach the Cable Holder to the Z axis, then lock the Toolhead Cable into place.

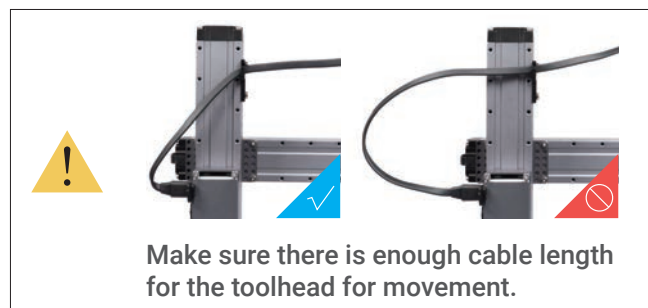
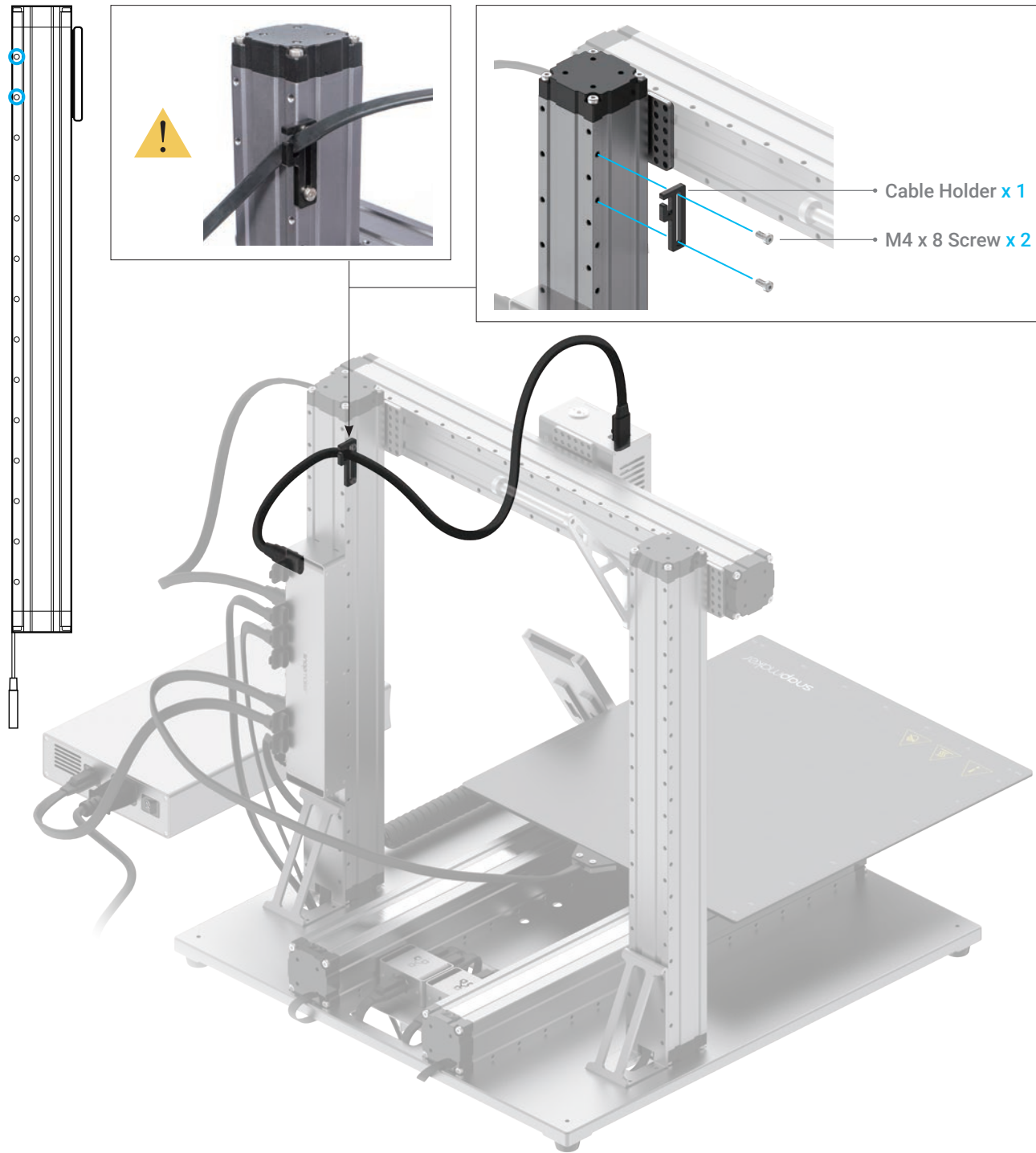

3.1.2 Initial Setup

Guides & Pictures / Snapmaker

Plug the AC Power Cable into an electrical outlet. Switch the power on and follow the prompts on the touchscreen: Read the Terms -> Name the Machine -> Connect to a Wi-Fi Network.



 It is recommended to wait for 5 seconds when you turn your machine off and on again.

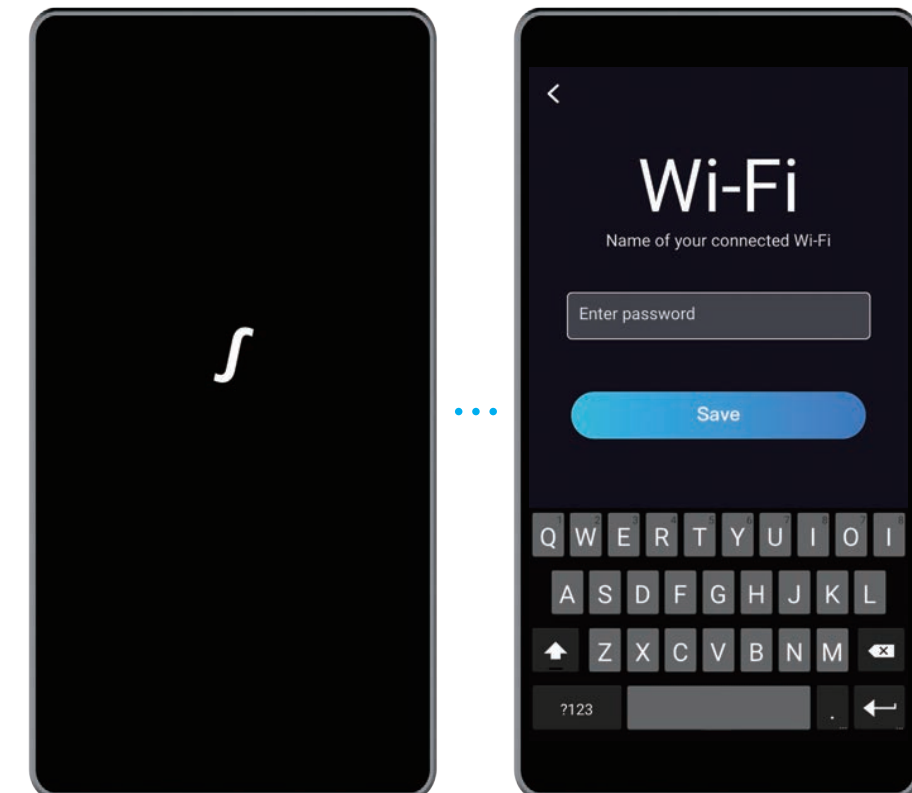

 Please skip this step if you have completed the initial setup. If you need to change the settings above, swipe left on the home page of the touchscreen -> select **Settings** -> tap **Wi-Fi** or **About Machine** as needed.

 The initial guide, which helps you get started, will appear only once. If you need to launch it again, swipe left on the home page of the touchscreen -> select **Settings** -> tap **Guides**.

3.2.1 Calibrate the Bed

Guides & Pictures / Snapmaker

How It Works: Auto Leveling

The 3D printing module conducts a compensation leveling procedure, with the sensor measuring the distance between the nozzle and the heated bed at specific points. The movements of the extruder are adjusted to ensure that the nozzle and the heated bed are at an optimum distance throughout the printing process.

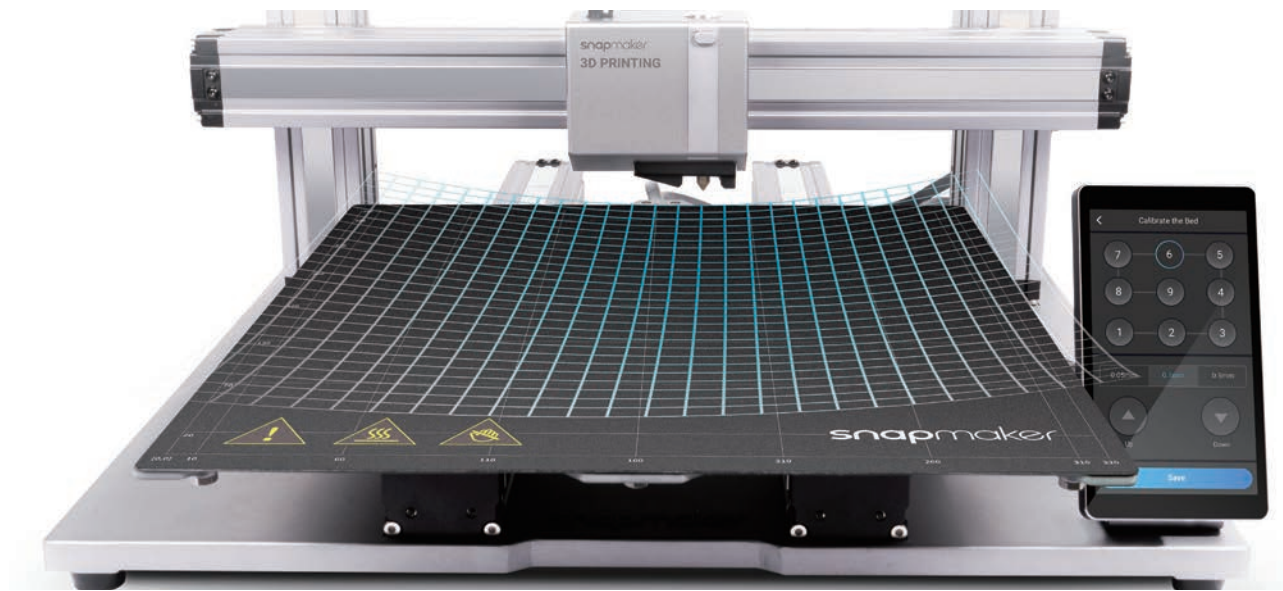

How It Works: Adjusting the Z Offset

Z Offset is the distance between the tip of the nozzle and the print surface. Adjusting the Z Offset is the process of tweaking the height of the nozzle by tiny increments. A proper Z Offset value helps ensure the first layer of your print sticks to the print sheet.

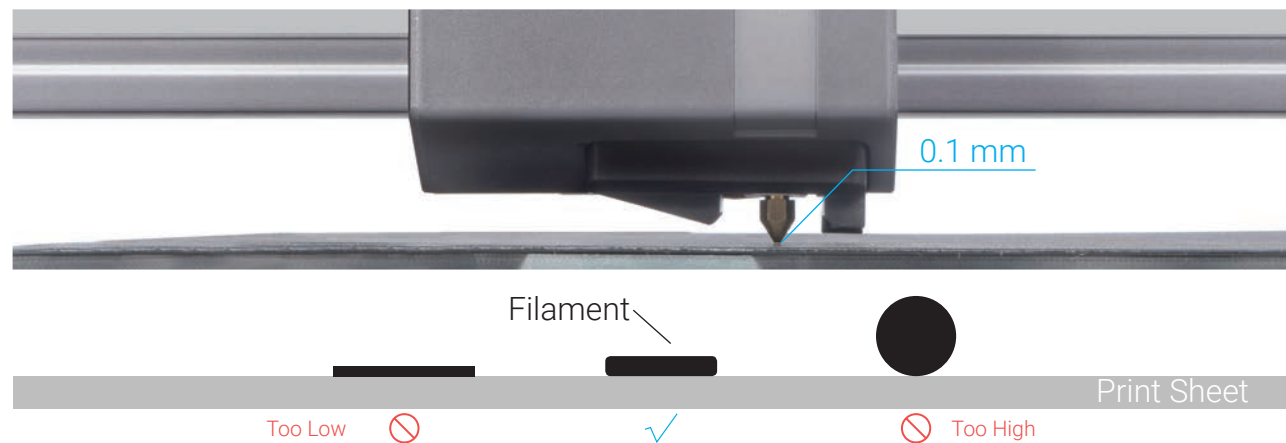

How to Level

1. Run the Auto Leveling procedure on the touchscreen.
2. Place the calibration card or a piece of A4 paper between the nozzle and the heated bed, and manually calibrate the Z Offset for the last point.



3. Keep adjusting the height of the nozzle using **Up** and **Down** buttons until there is slight resistance when you pull out the calibration card, and it should be wrinkled when you push it forward. Tap **Save** to save the calibration settings.

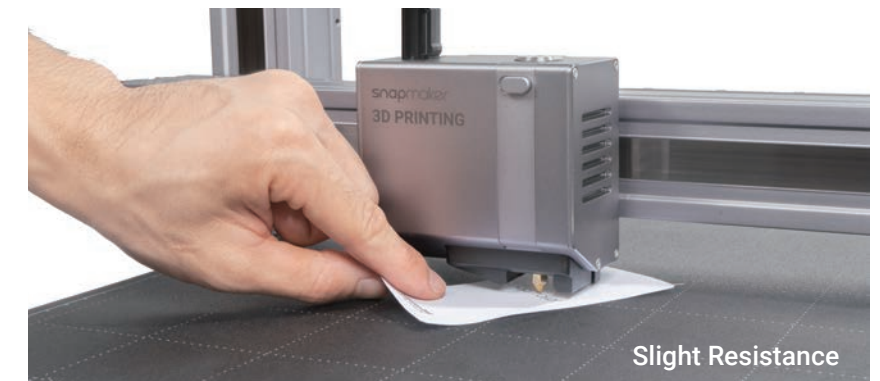
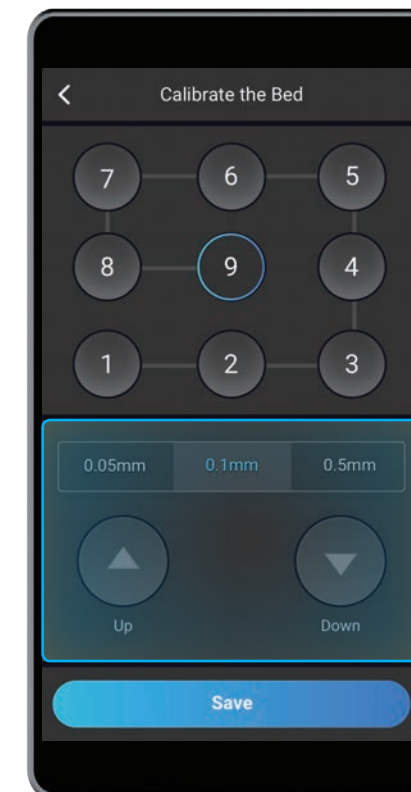

3.2.2 Load Filament

Guides & Pictures / Snapmaker

How It Works: Filament Loading

The motor drives the filament into the extruder, then the filament extrudes through the nozzle after being heated by the heated block.

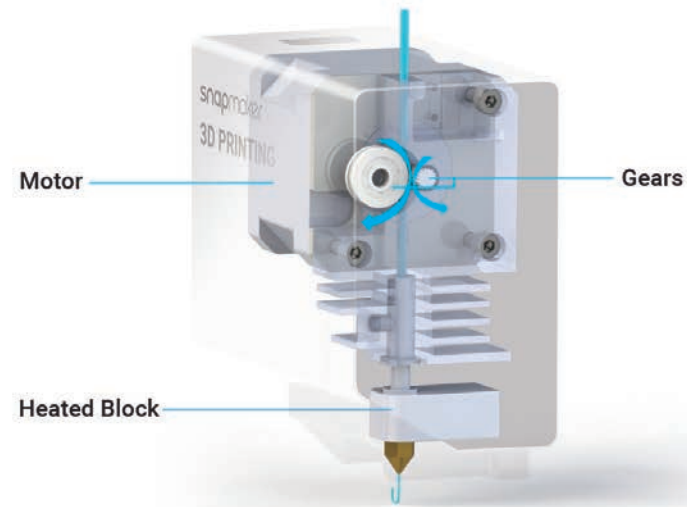

How to Load Filament

1. Hang the provided PLA filament over the filament holder. Cut the bending end of the filament using the diagonal pliers, then insert the filament into the 3D printing module.

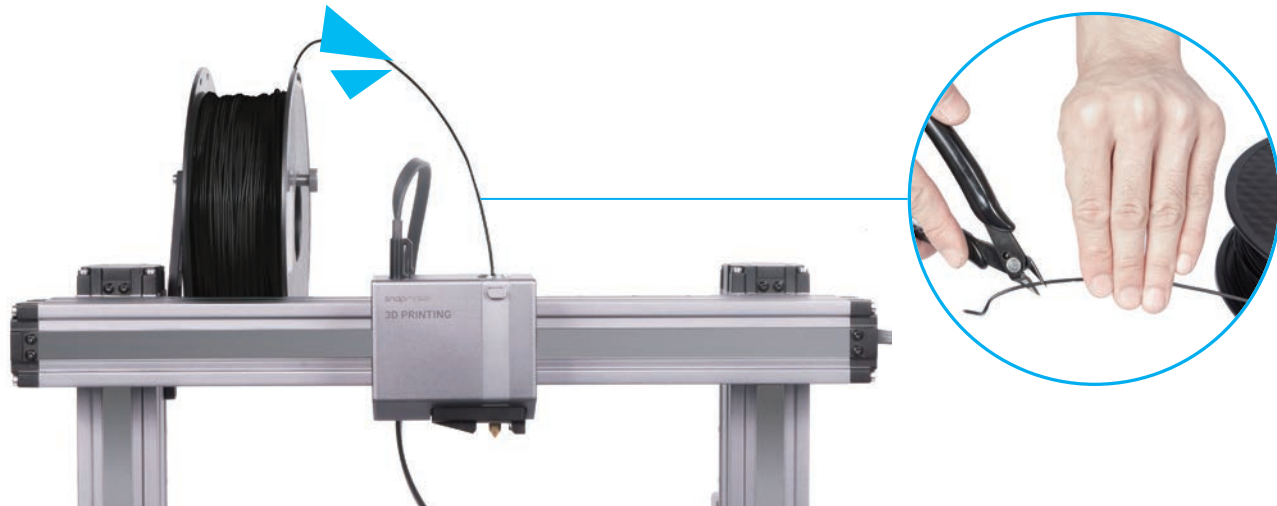

2. Tap **Start** on the **Load Filament** screen. After the temperature reaches the target temperature, tap **Load** and then gently push the filament into the 3D printing module until you can feel the motor pulling the filament in.

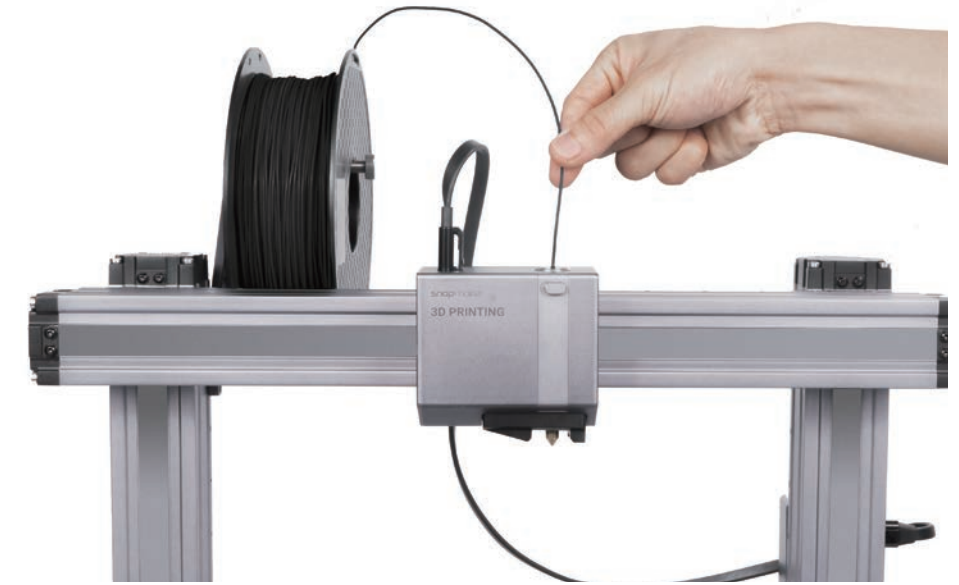
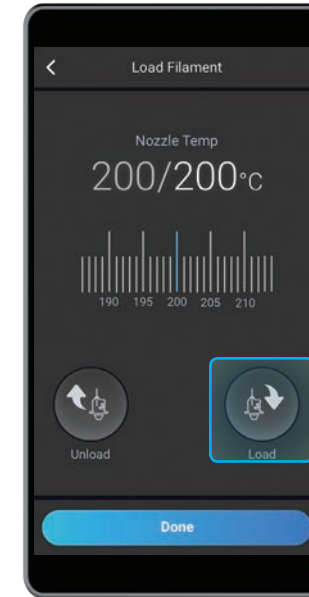

You can change the target **Nozzle Temp** by sliding the scale bar.

3. Clean the nozzle using the tweezers, then tap **Done**.

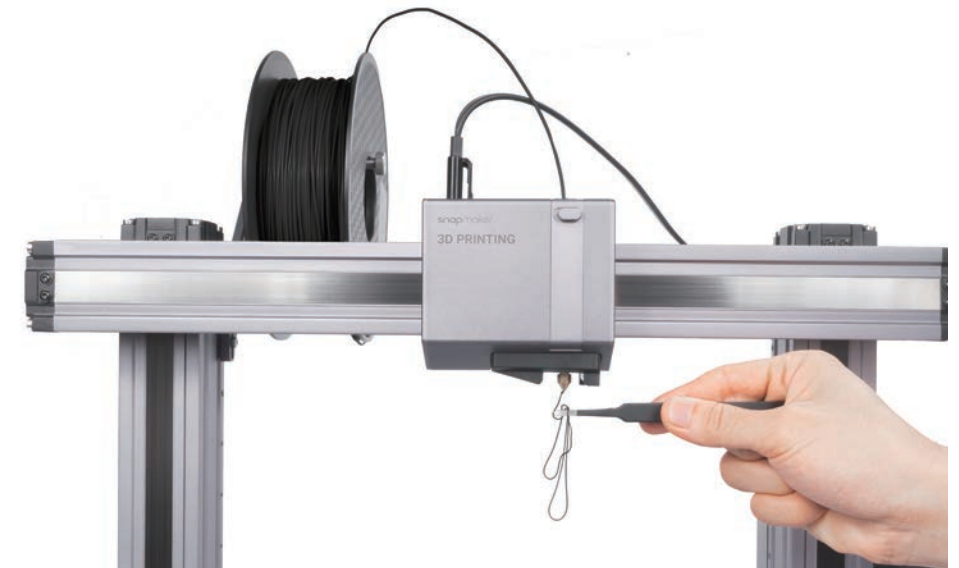
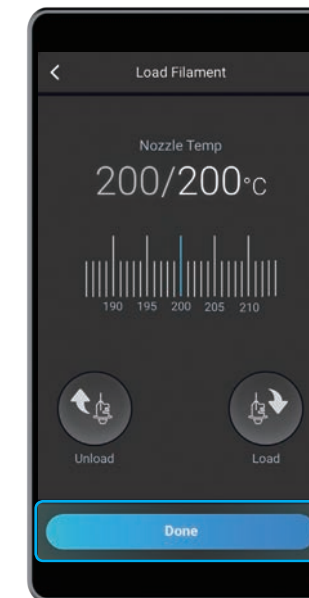

If there is no filament coming out of the nozzle, do not tap **Done** until you repeat the steps above and the filament extrudes successfully.



Congratulations!

You are now ready to print. Please continue to generate the G-code file.



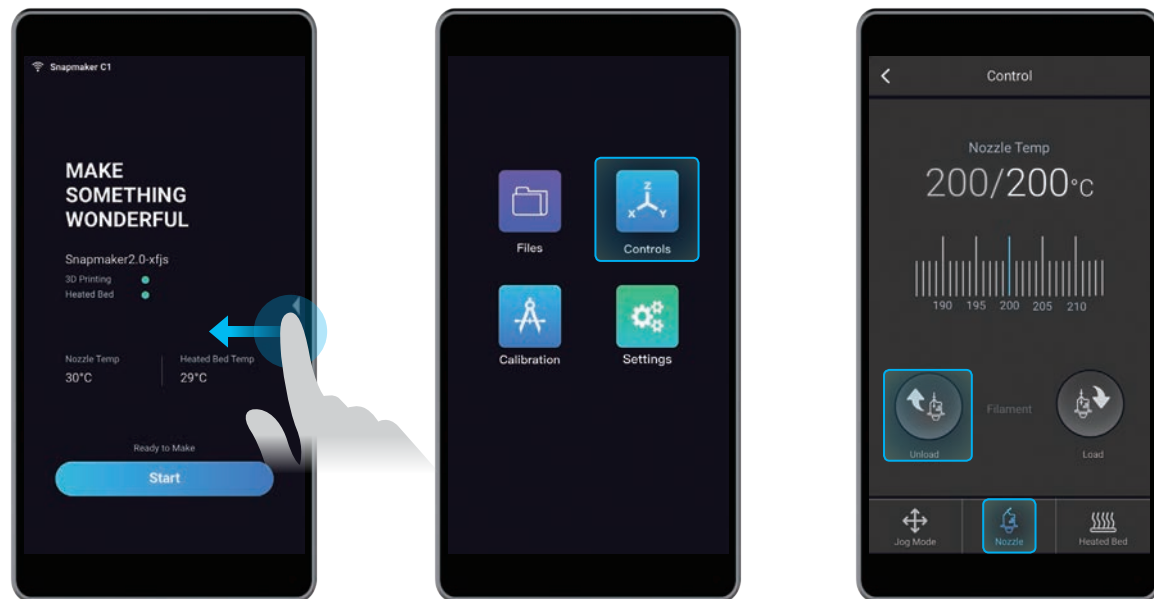

When you need to change the filament, select **Controls** and **Nozzle**. After the temperature reaches the target temperature, tap **Unload** and pull the filament out of the module.



3.3.1 Prepare the G-code File

Guides & Pictures / Snapmaker

1. Install the Software and Complete the Initial Setup

Download our software Snapmaker Luban at <https://snapmaker.com> and install it. Then connect to a Wi-Fi network: Enter the Workspace  -> Connection -> Select **Wi-Fi** -> Click  -> Select your machine -> Click **Open** -> Tap **Yes** on the touchscreen.

2. Generate the G-code File and Send It to the Machine

① Load the test file -> ② Use the default settings specifically configured for the test file -> ③ Generate the G-code file -> ④ Load G-code to Workspace -> ⑤ Send G-code to the machine via Wi-Fi.



You can also upload your own files by clicking **Open File** and configure the file settings. For more instructions, please refer to our online user manual.

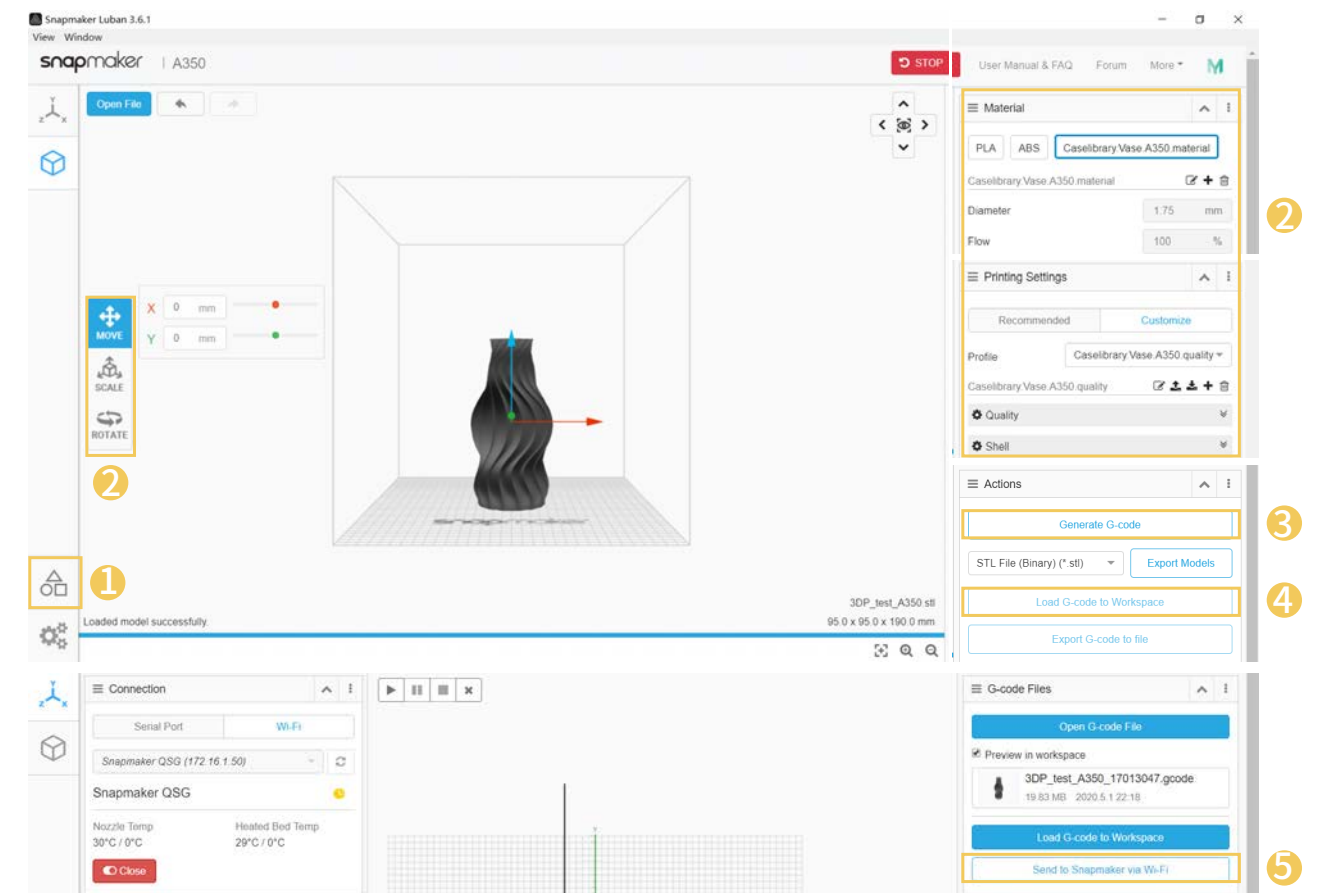

Files sent by Wi-Fi can be found on the touchscreen: **Files > Local**.



You can also send the G-code files to the machine via the USB disk. Click **Export G-code to file** in Snapmaker Luban and save it to the USB disk, then insert the USB disk into the controller and select **Files > USB** on the touchscreen.

3.3.2 Start Your First Print

After receiving the G-code file, tap **Yes** and **Start** on the touchscreen to start printing.

If you need to adjust settings, you can either tap **Adjust Settings** prior to printing or swipe left on the printing progress screen.

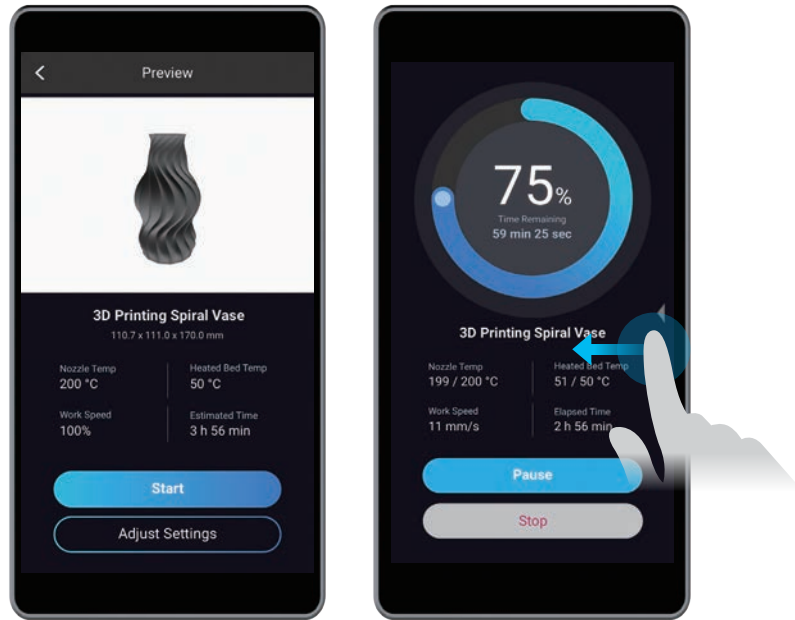

If you run into the issue of poor adhesion, swipe left on the printing progress screen and you can try adjusting the Z Offset. Or you can try leveling the heated bed again by selecting **Calibration**. Make sure the tip of the nozzle is clean before you calibrate the bed.

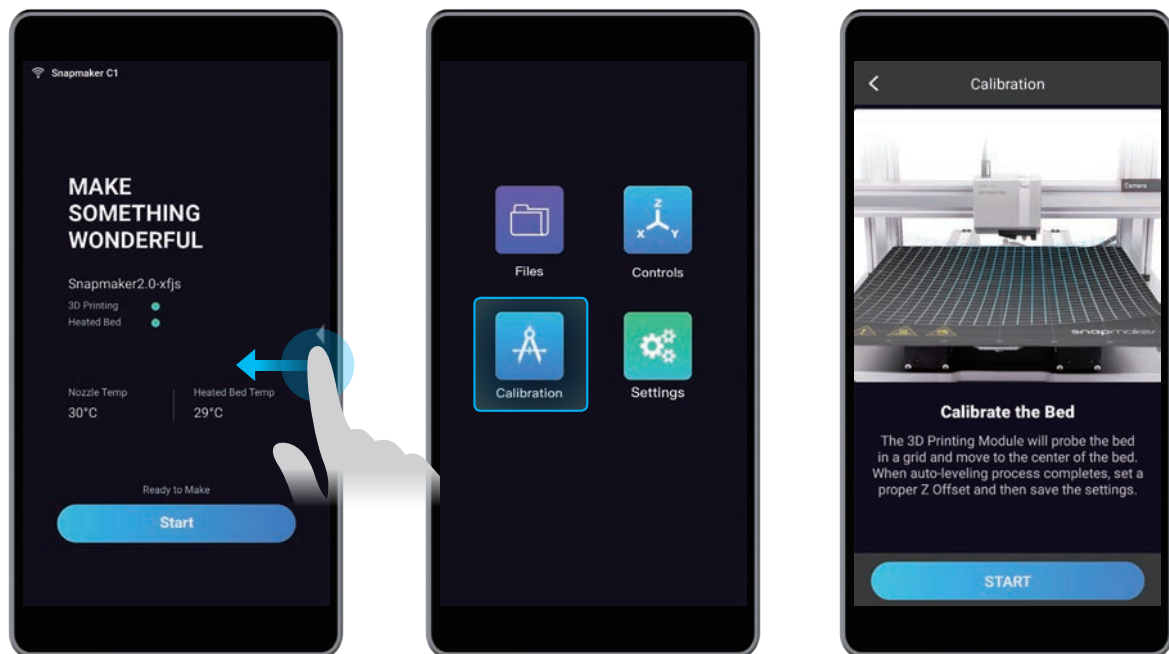

3.3.3 Remove the Print

Wait for the temperatures of the nozzle and the heated bed to drop to room temperature (displayed on the touchscreen) . Remove the print sheet from the heated bed and bend it slightly.



Remove the print sheet from the heated bed, place it down on a stable and flat surface. You can also use the palette knife to remove the print.







Share!

You can share your prints in our Facebook group and our forum.

Laser Engraving and Cutting

4.1 Assembly

- 4.1.1 Assemble the Laser Engraver and Cutter
- 4.1.2 Initial Setup

4.2 Get Started

- 4.2.1 Measure the Focal Length
- 4.2.2 Calibrate the Camera
- 4.2.3 Fix the Material

4.3 Prepare the G-code File and Start Cutting



4.1.1 Assemble the Laser Engraver and Cutter

Guides & Pictures / Snapmaker

01/04

Attach the Laser Module to the slider on the X axis.

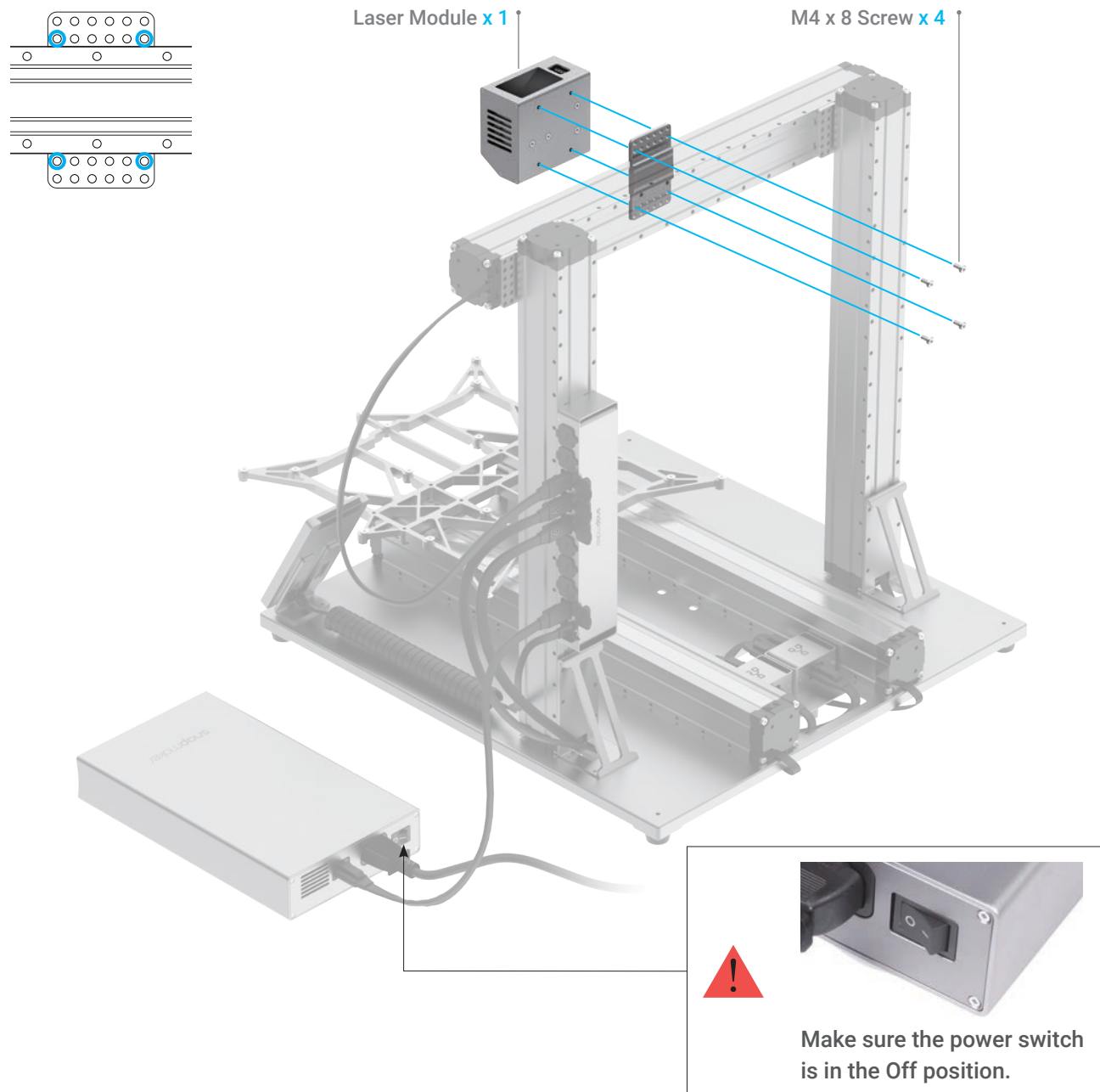

02/04

Connect the Laser Module to the Controller.

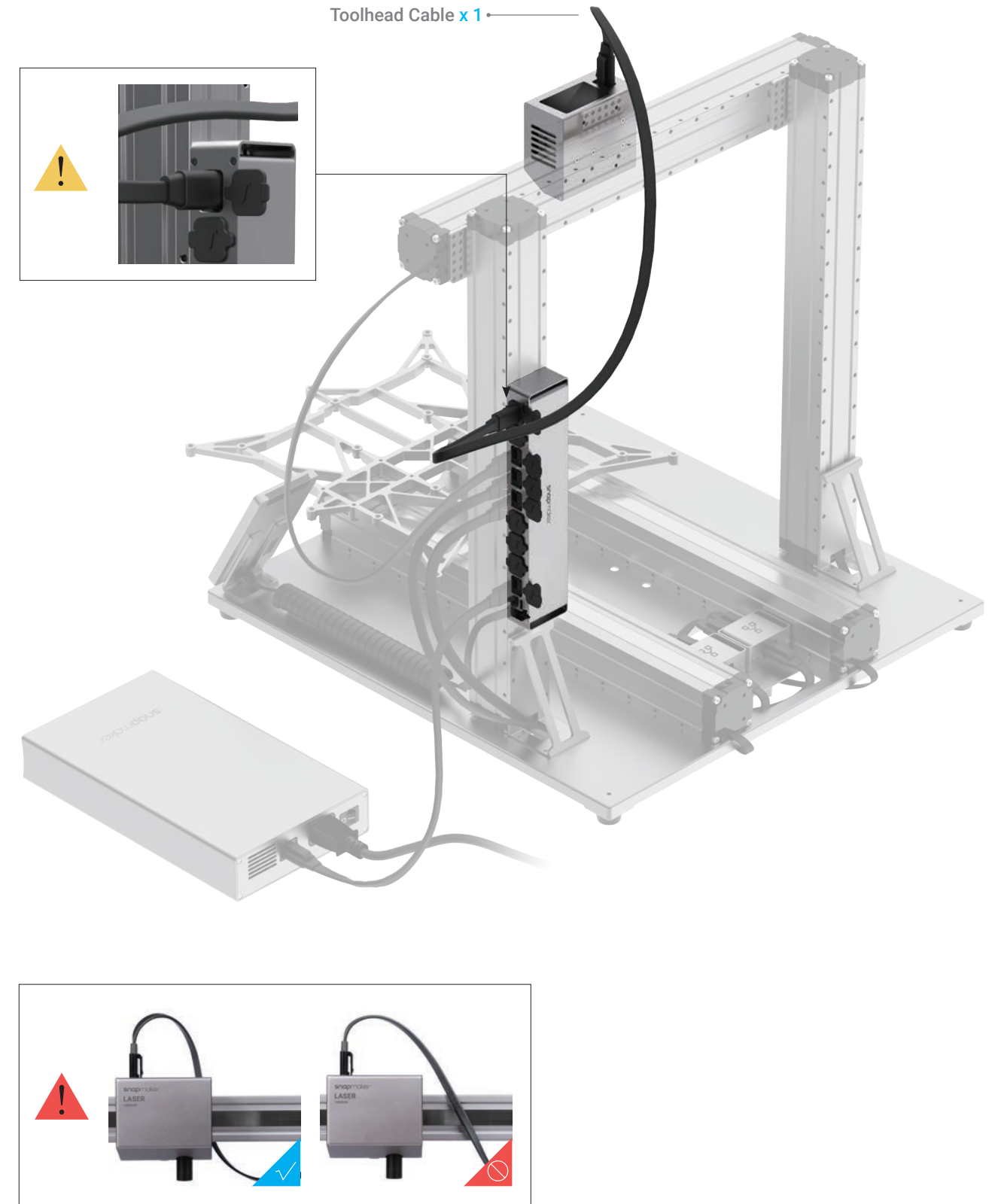

03/04

Attach the Laser Engraving/Cutting Platform to the Platform.

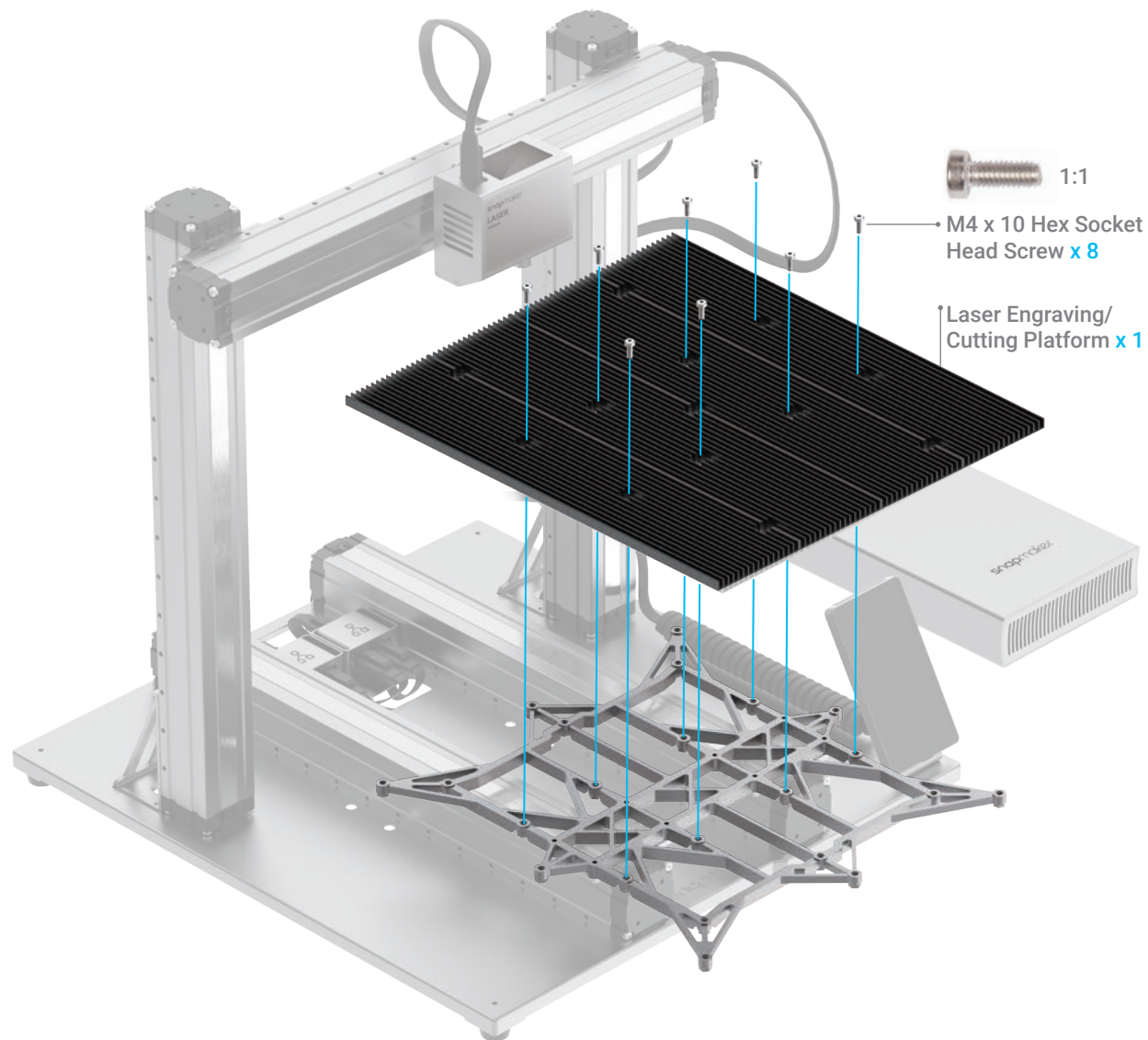
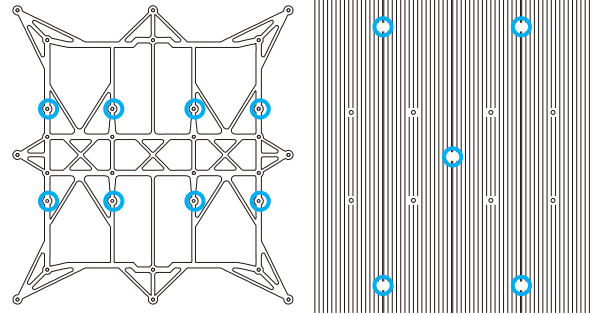

04/04

Attach the Cable Holder to the Z axis, then lock the Toolhead Cable into place.

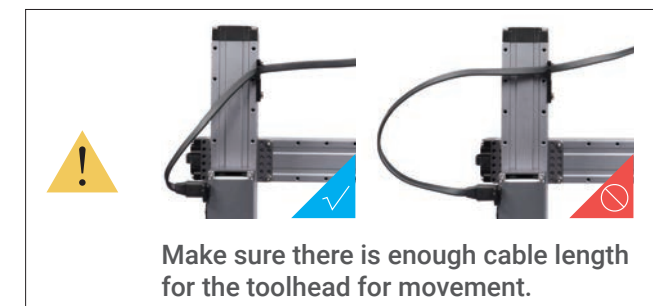
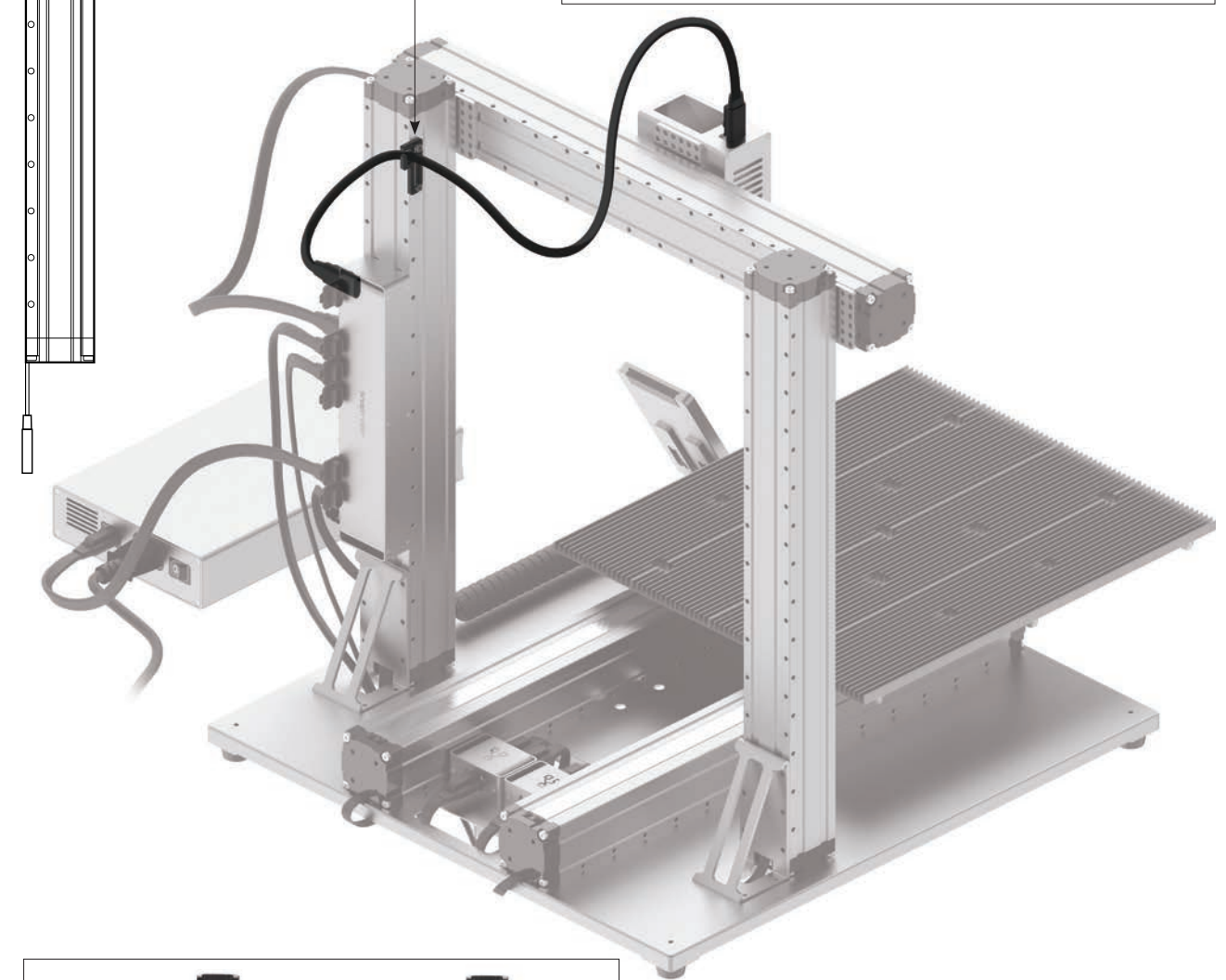
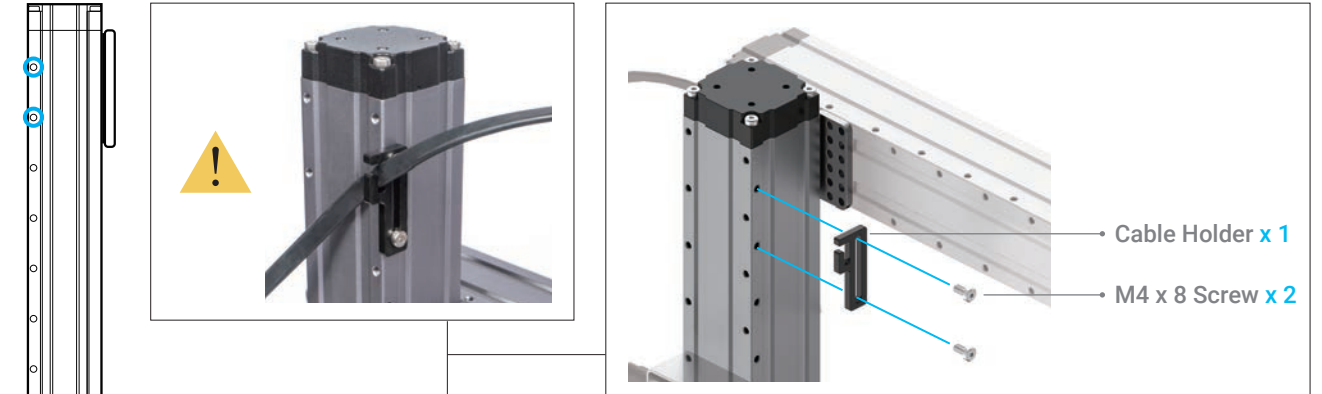

4.1.2 Initial Setup

Plug the AC Power Cable into an electrical outlet. Switch the power on and follow the prompts on the touchscreen: Read the Terms -> Name the Machine -> Connect to a Wi-Fi Network.



It is recommended to wait for 5 seconds when you turn your machine off and on again.

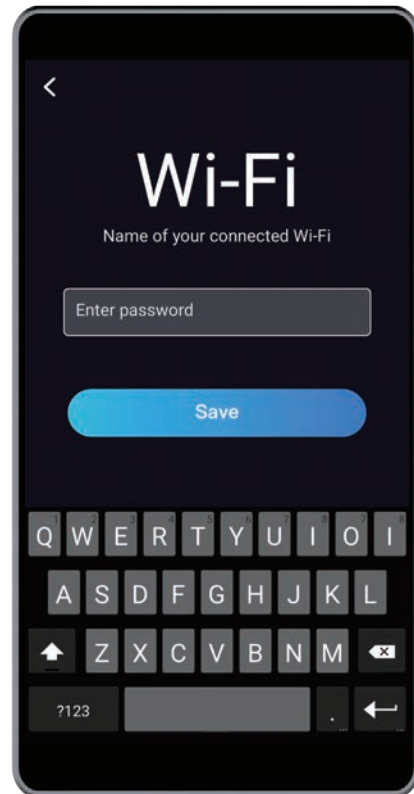

Please skip this step if you have completed the initial setup. If you need to change the settings above, swipe left on the home page of the touchscreen -> select **Settings** -> tap **Wi-Fi** or **About Machine** as needed.



The initial guide, which helps you get started, will appear only once. If you need to launch it again, swipe left on the home page of the touchscreen -> select **Settings** -> tap **Guides**.

4.2.1 Measure the Focal Length

How It Works: Focal Point

The best focusing result can only be achieved when the Focal Point is right on the surface of the material throughout engraving or cutting.

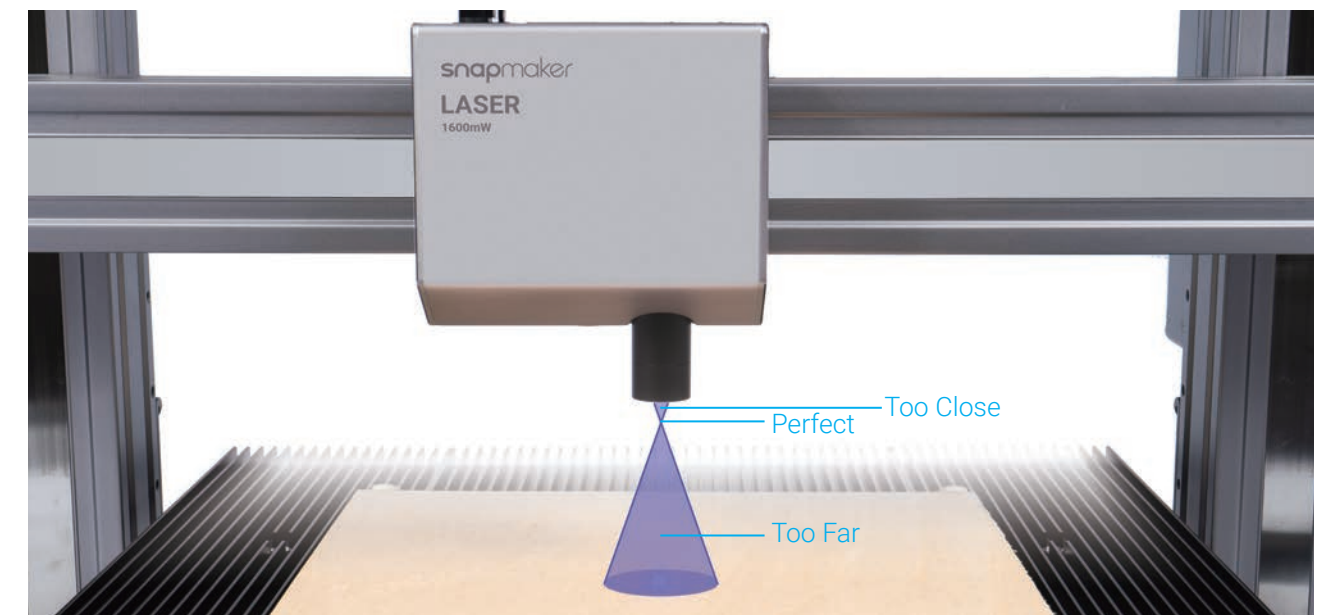

How It Works: Focal Length

The machine engraves a few lines at different heights and identify the line of the best engraving result. The distance between the laser module and the material surface, which is used for engraving this line, will be used as focal length. You just need to set the thicknesses of different materials once the focal length has been determined, the machine will automatically adjust to ensure that the focal length is consistent.



How It Works: Work Origin

Find out where the engraving/cutting will be by setting the work origin. The work origin corresponds to the (0, 0) coordinate origin in the software.

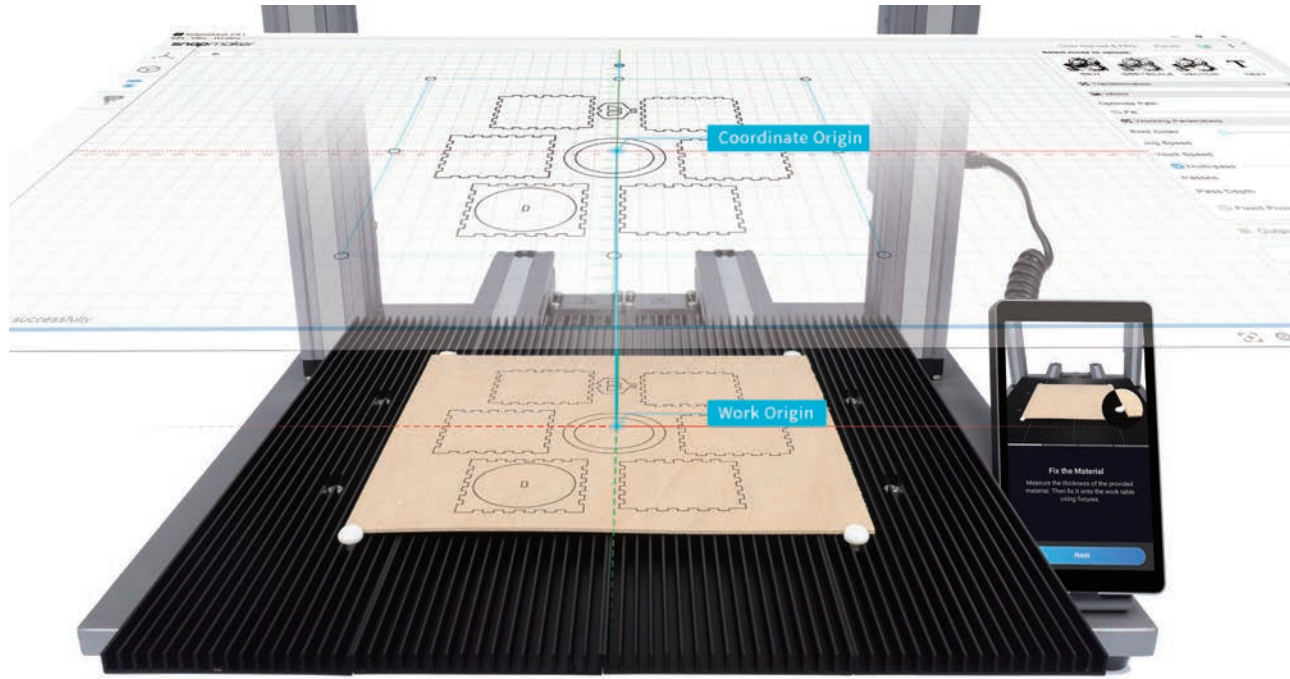

2. Set the thickness of the material (1.5mm) and tap **Save**.

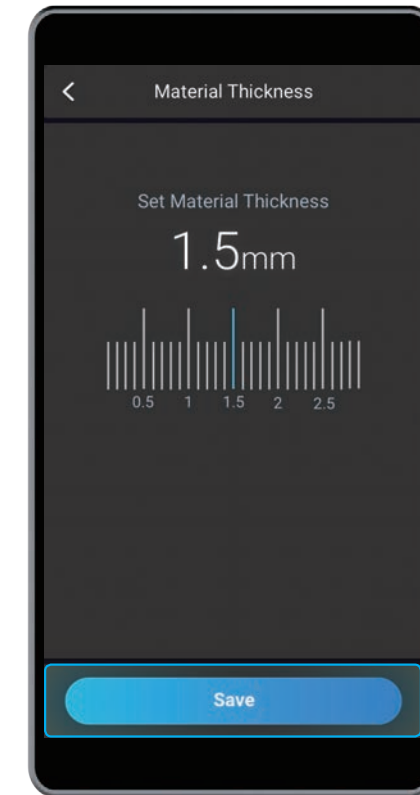

How to Measure the Focal Length

1. Place the provided material on the laser engraving/cutting platform, then fix it using the silicone plugs.

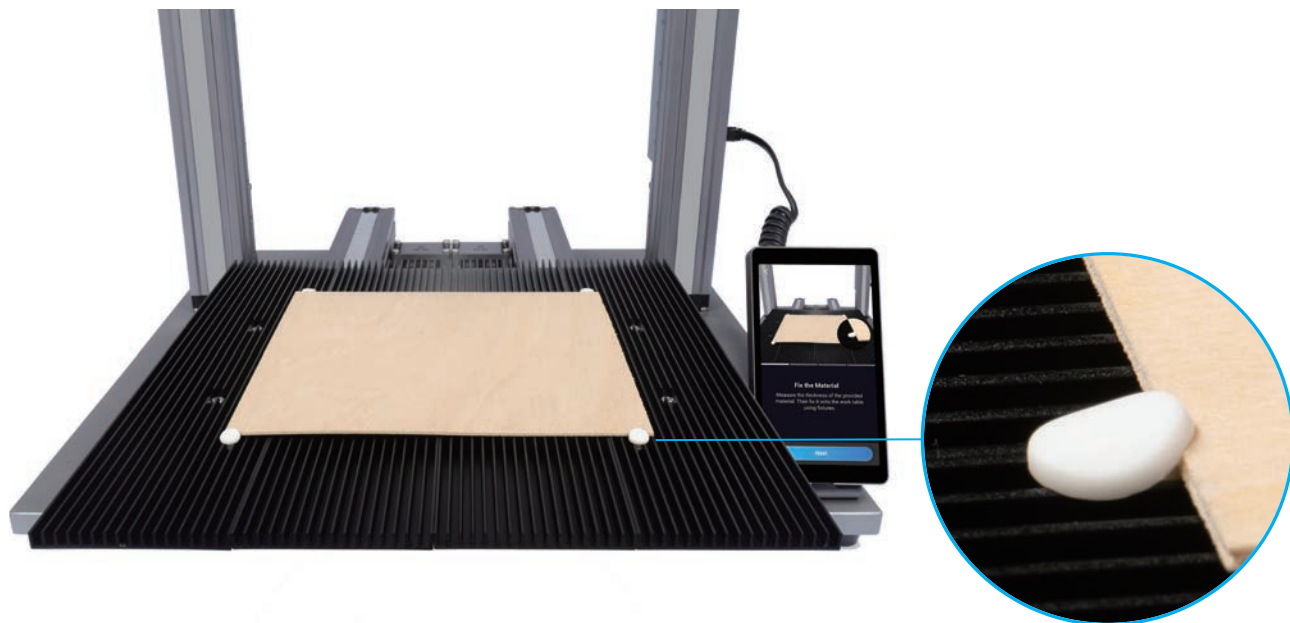

3. Tap **X-/X+/Y-/Y+/Z-/Z+** to move the laser module. After the laser shade has slightly touched the surface of the material, tap **Next**. Make sure you have worn the Laser Safety Goggles before setting the work origin.

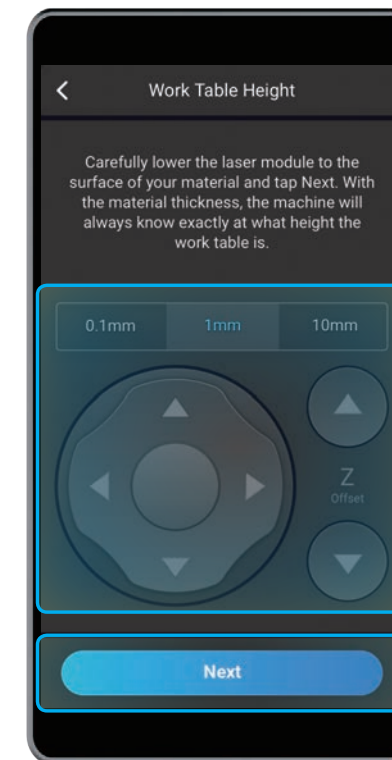

4. Tap **X-/X+/Y-/Y+** to move the laser dot to where the work origin will be, then tap **Set Work Origin** and **Run Boundary** to check if the work origin is proper. If the work origin is improper, reset the work origin and run boundary again.

 If the laser module runs into any portions of the machine, turn off the machine immediately.

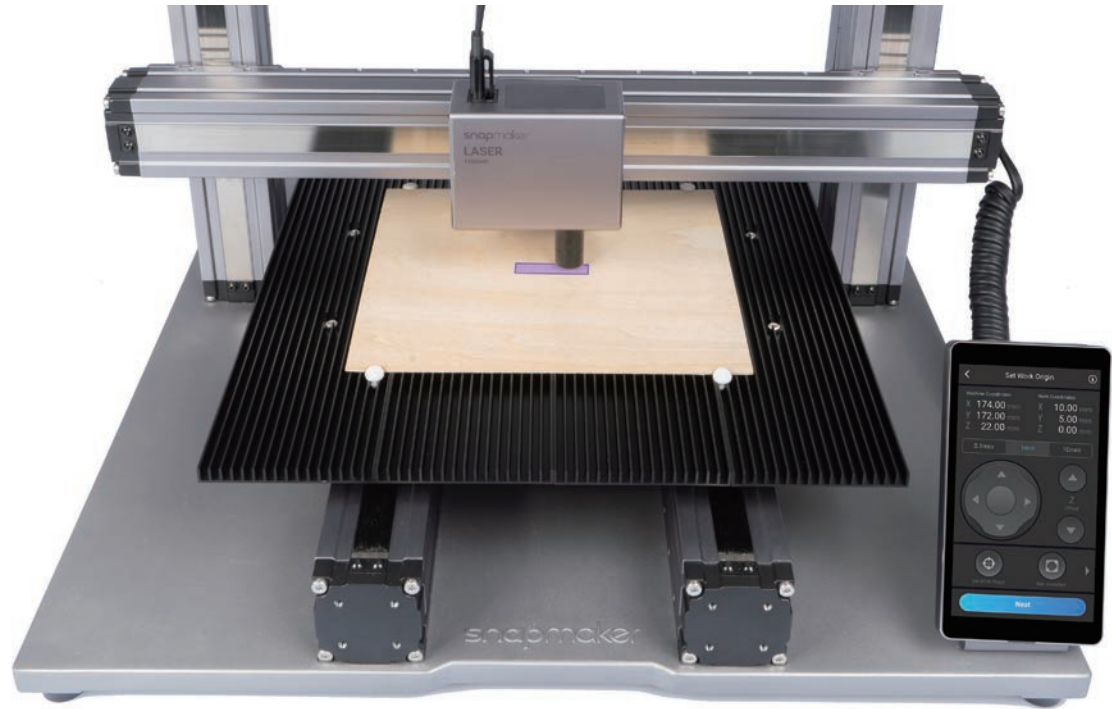

5. Tap **Start**, the machine will conduct an Auto Focus procedure.

 In the event of needing to remeasure the focal length and you are not sure how to proceed, please refer to our online user manual for detailed instructions.

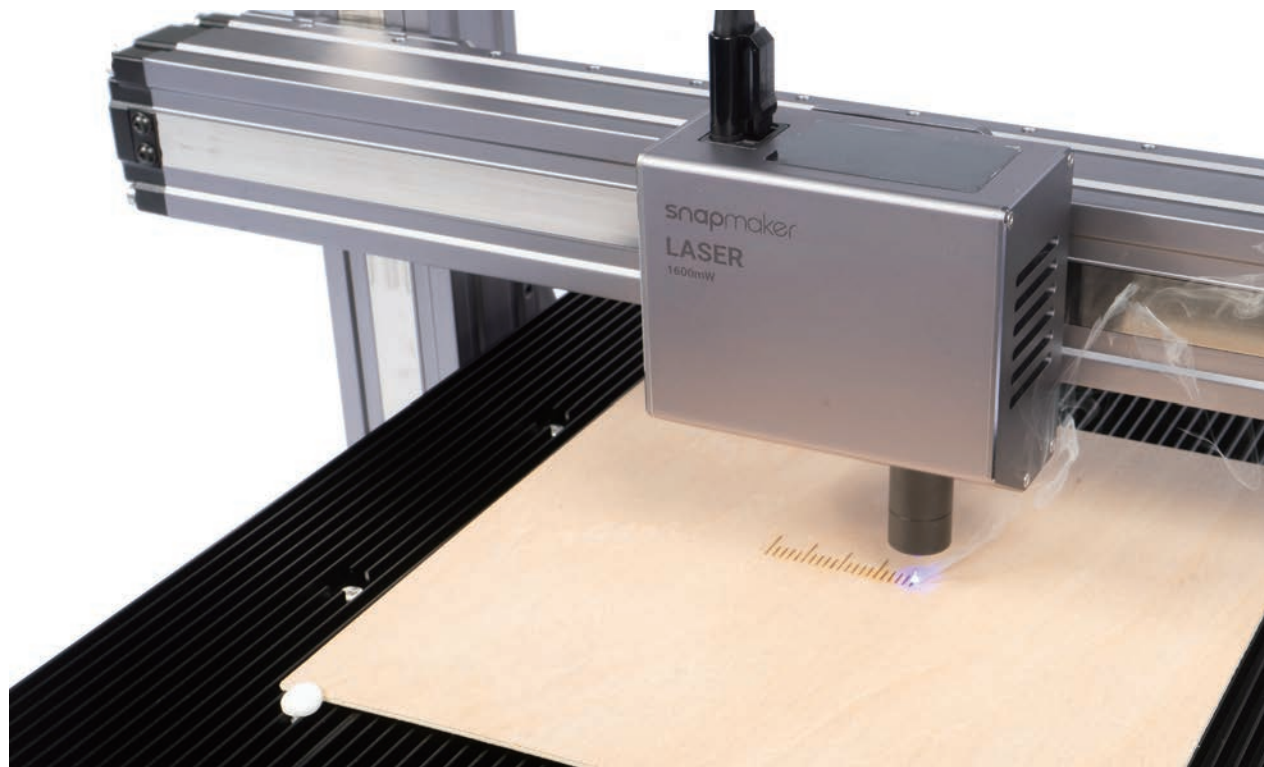

4.2.2 Calibrate the Camera

Guides & Pictures / Snapmaker

1. Remove the engraved material. Place a piece of white and blank paper (no less than 150mm x 150mm) on the center of the laser engraving/cutting platform, then fix it.

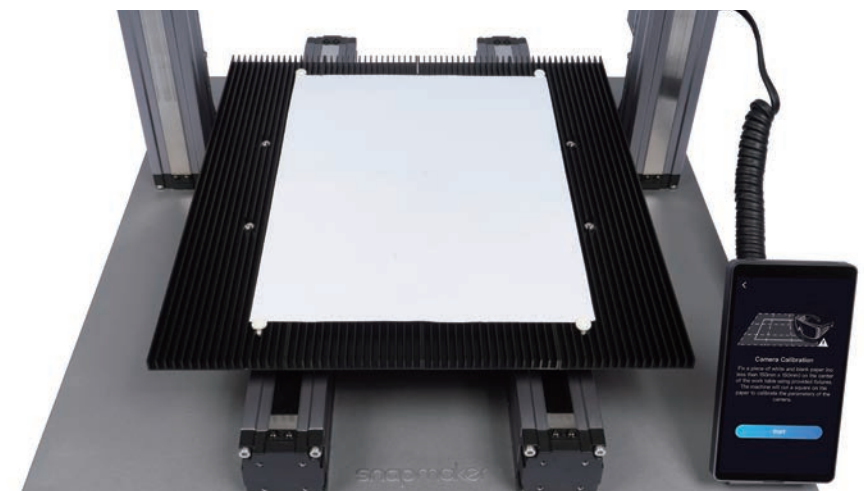

2. Tap **Start**, the machine will use the engraved square to calibrate the camera.

 If you have detached the laser module from the X axis, or if you have reassembled the machine, please recalibrate the camera: swipe left on the home page of the touchscreen -> select **Settings** -> tap **Laser** -> tap **Camera Calibration**.

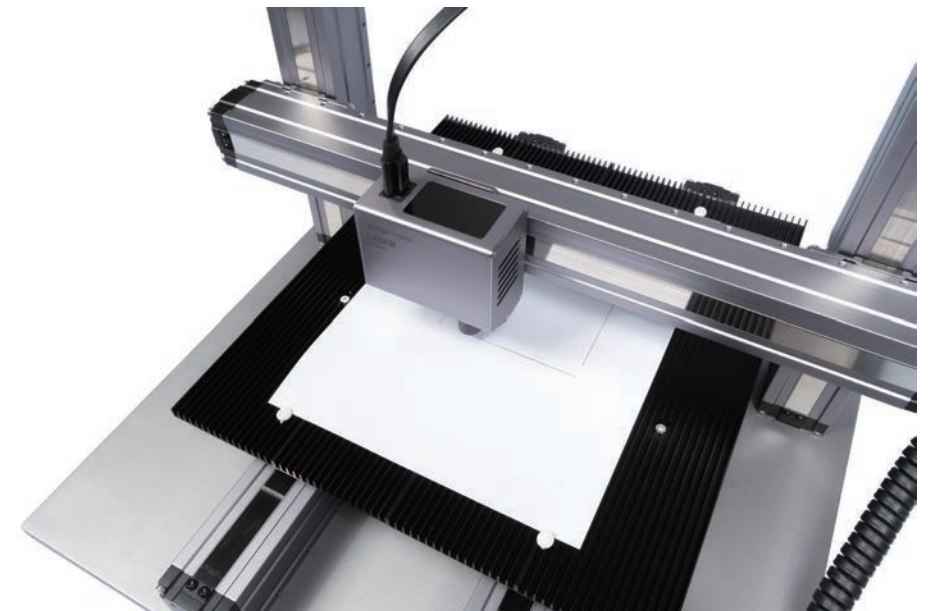
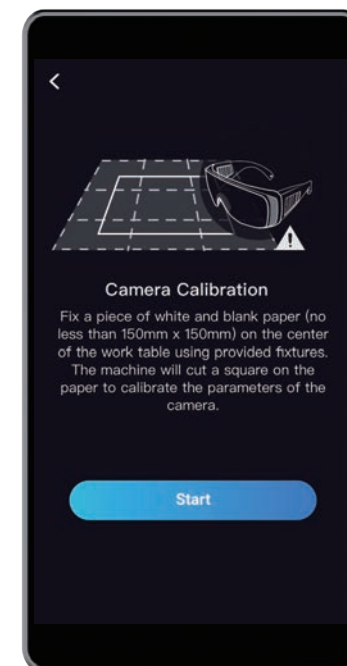

4.2.3 Fix the Material

Guides & Pictures / Snapmaker

Remove the engraved paper, then fix another provided material on the center of the laser engraving/cutting platform.



You can also fix materials using other tools.

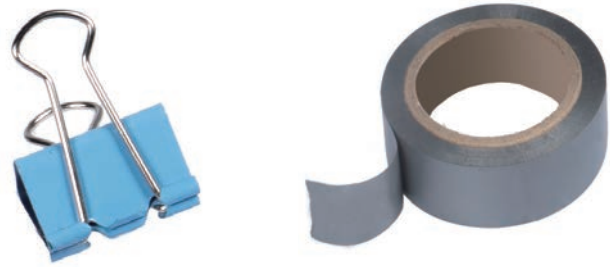

If you need to fix thick materials, refer to 5.2.1 Fix the Material.



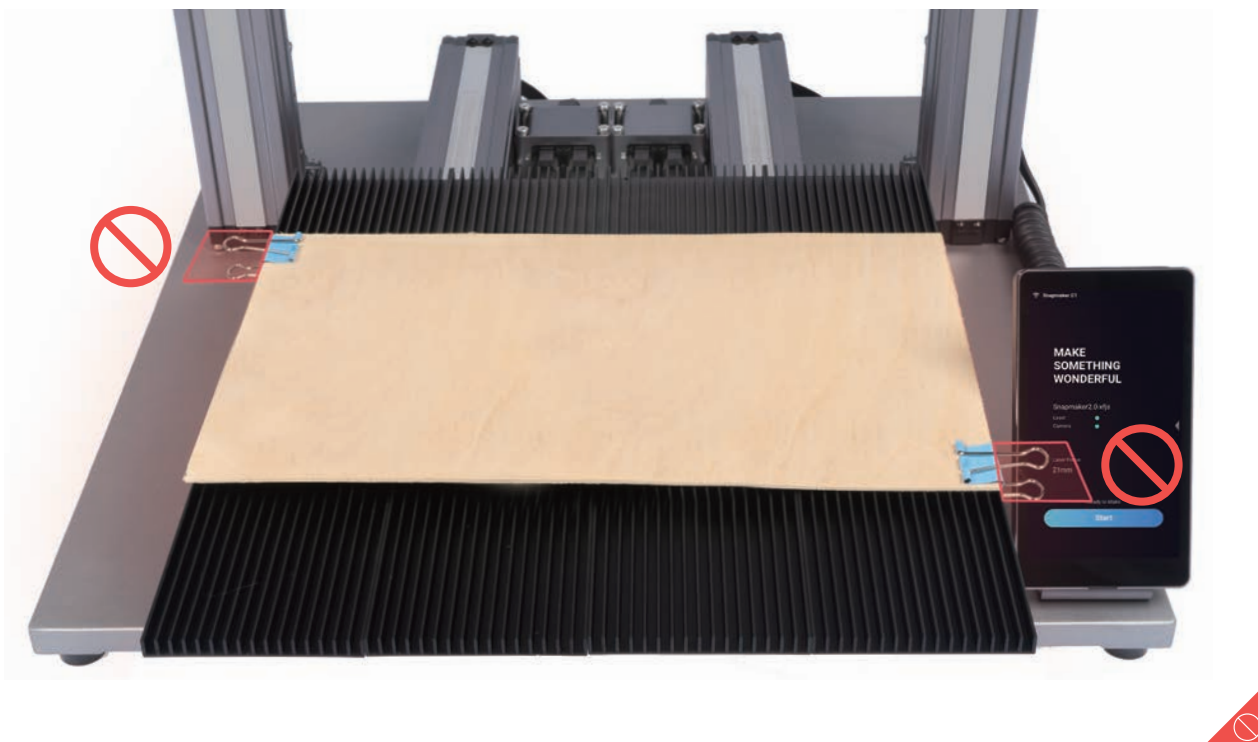

Make sure the clamp set will not collide with any portions of the machine.



4.3 Prepare the G-code File and Start Cutting

Guides & Pictures / Snapmaker

1. Download our software Snapmaker Luban at <https://snapmaker.com> and install it. Then connect to a Wi-Fi network: Enter the Workspace  -> Connection -> Select **Wi-Fi** -> Click  -> Select your machine -> Click **Open**-> Tap **Yes** on the touchscreen.

2. Click **Camera Capture** in the laser G-code generator  and then click **Start**. Wait for the machine to take photos and stitch them into a panorama of the platform, click **Confirm**.

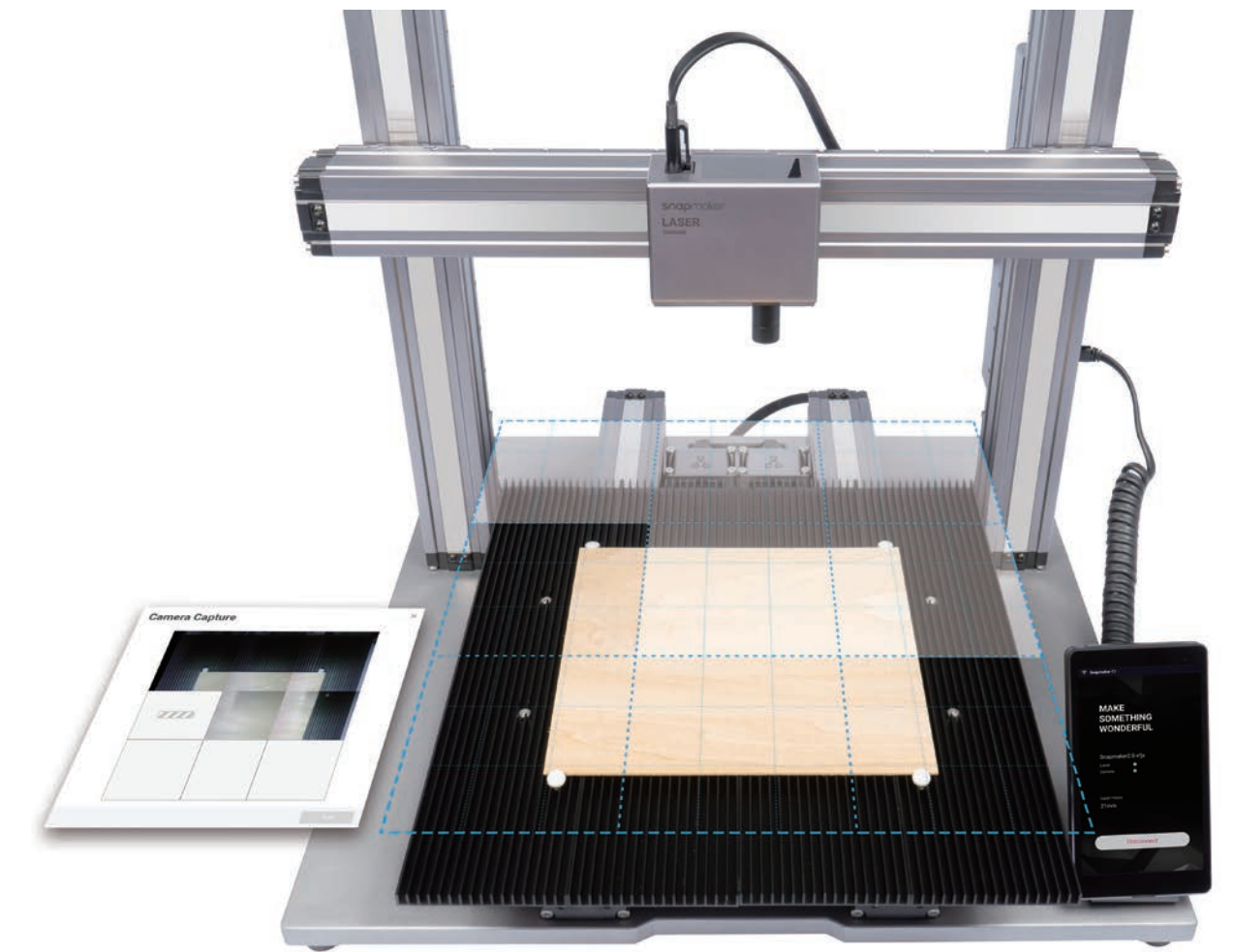

If you find the edges of the captured image are not aligned, you shall click **Calibration** to manually calibrate the camera.

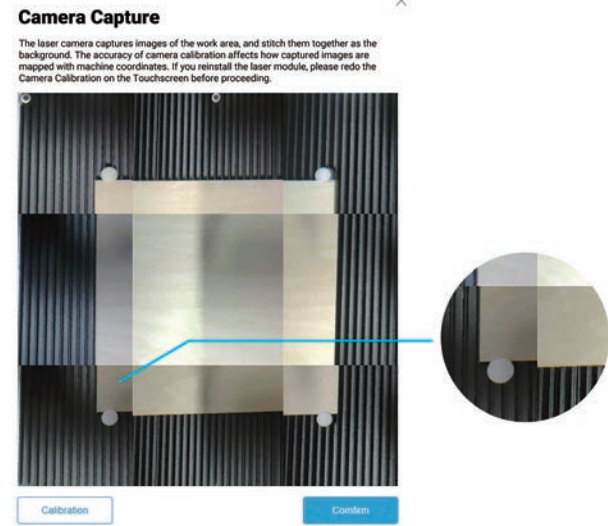

Zoom into the image and move the lines until they perfectly match the square, click **Confirm** -> **Apply** to see the finished image.

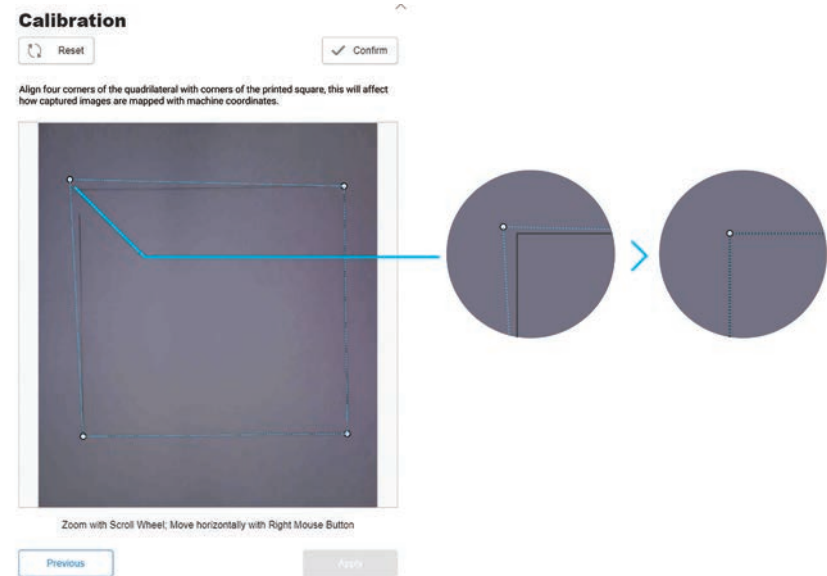

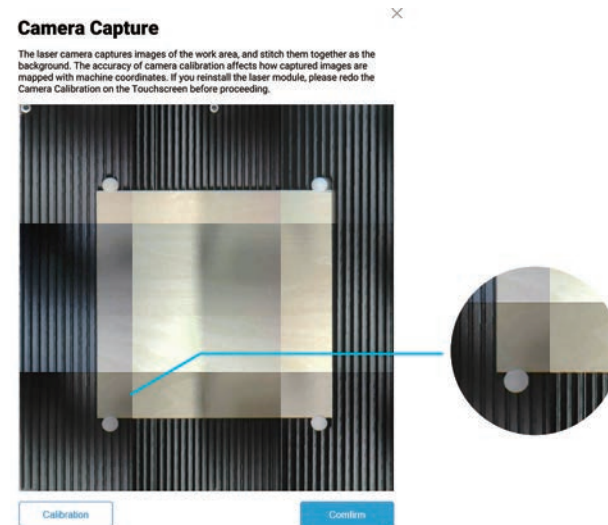

Click **Confirm** and the finished image will be loaded into the quadrant in the coordinate system. You can repeat the steps above if the edges of the captured image are still not aligned.

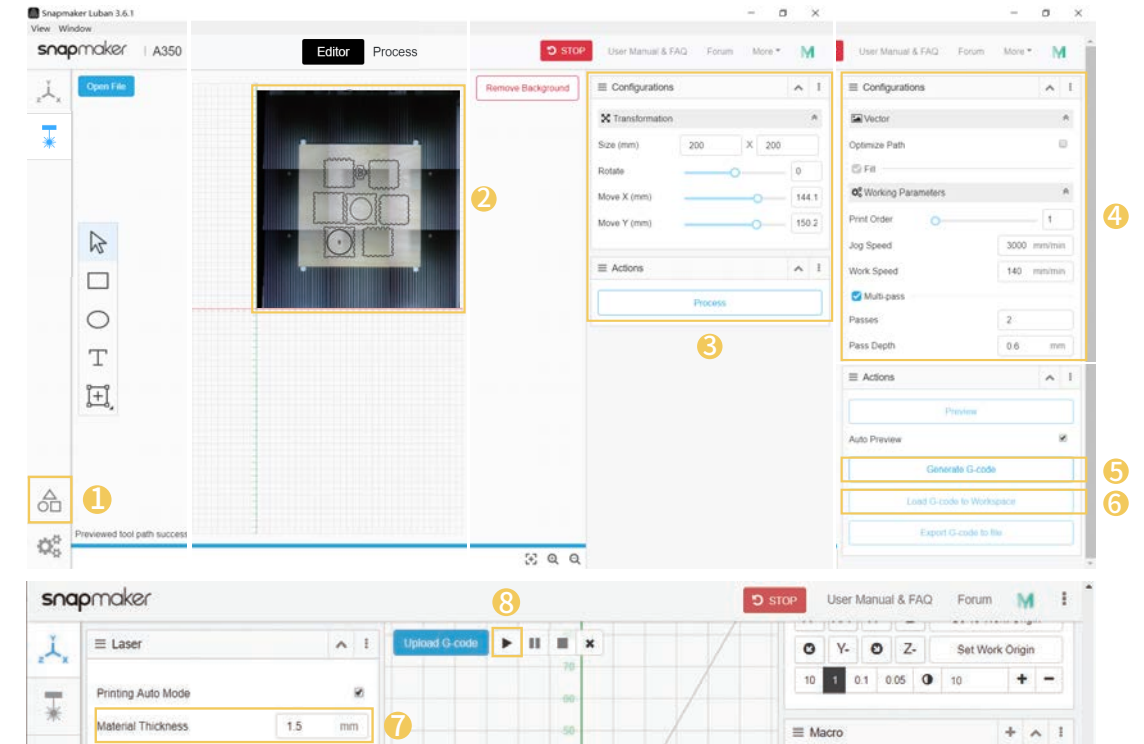

3. ① Open the test file from **Case Library** -> ② Drag the image to where the cutting will be on the captured platform -> ③ Click **Process** after configuring the settings in **Configurations** section -> ④ Use the default settings specifically configured for the test file -> ⑤ Generate the G-code file -> ⑥ Load G-code to **Workspace** -> ⑦ Set the thickness of the material -> ⑧ Click **Run** ▶ .

 You can also upload your own files by clicking **Open File** in **Editor** and configure the file settings.



 You can also start engraving/cutting by using the USB disk, connecting with the USB cable, or sending G-code files via Wi-Fi. For detailed instructions, please refer to our online user manual. Unlike the Camera Capture method, you will need to set the work origin if you use the methods above.

4. Remove the finished work and complete the assembly.

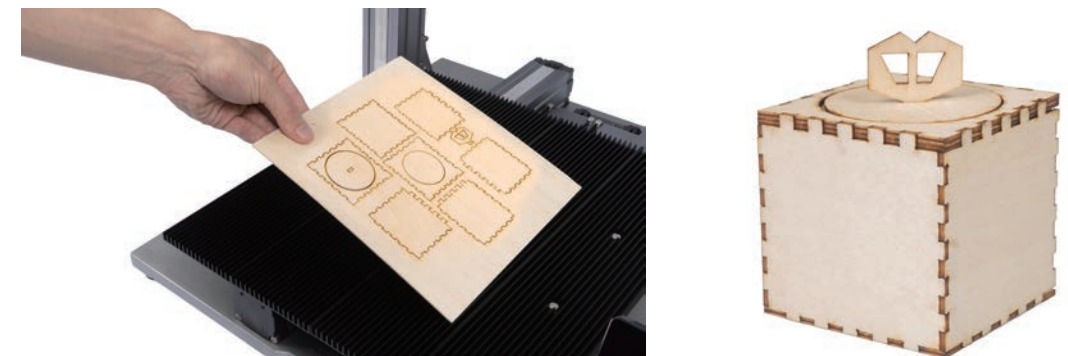





Share!

You can share your finished work in our Facebook group and our forum.

CNC Carving

5.1 Assembly

- 5.1.1 Assemble the CNC Carver
- 5.1.2 Initial Setup

5.2 Get Started

- 5.2.1 Fix the Material
- 5.2.2 Attach the Bit

5.3 Start Carving

- 5.3.1 Prepare the G-code File
- 5.3.2 Set the Work Origin and Start Carving
- 5.3.3 Clean the Finished Work



5.1.1 Assemble the CNC Carver

01/04

Attach the CNC Module to the slider on the X axis.

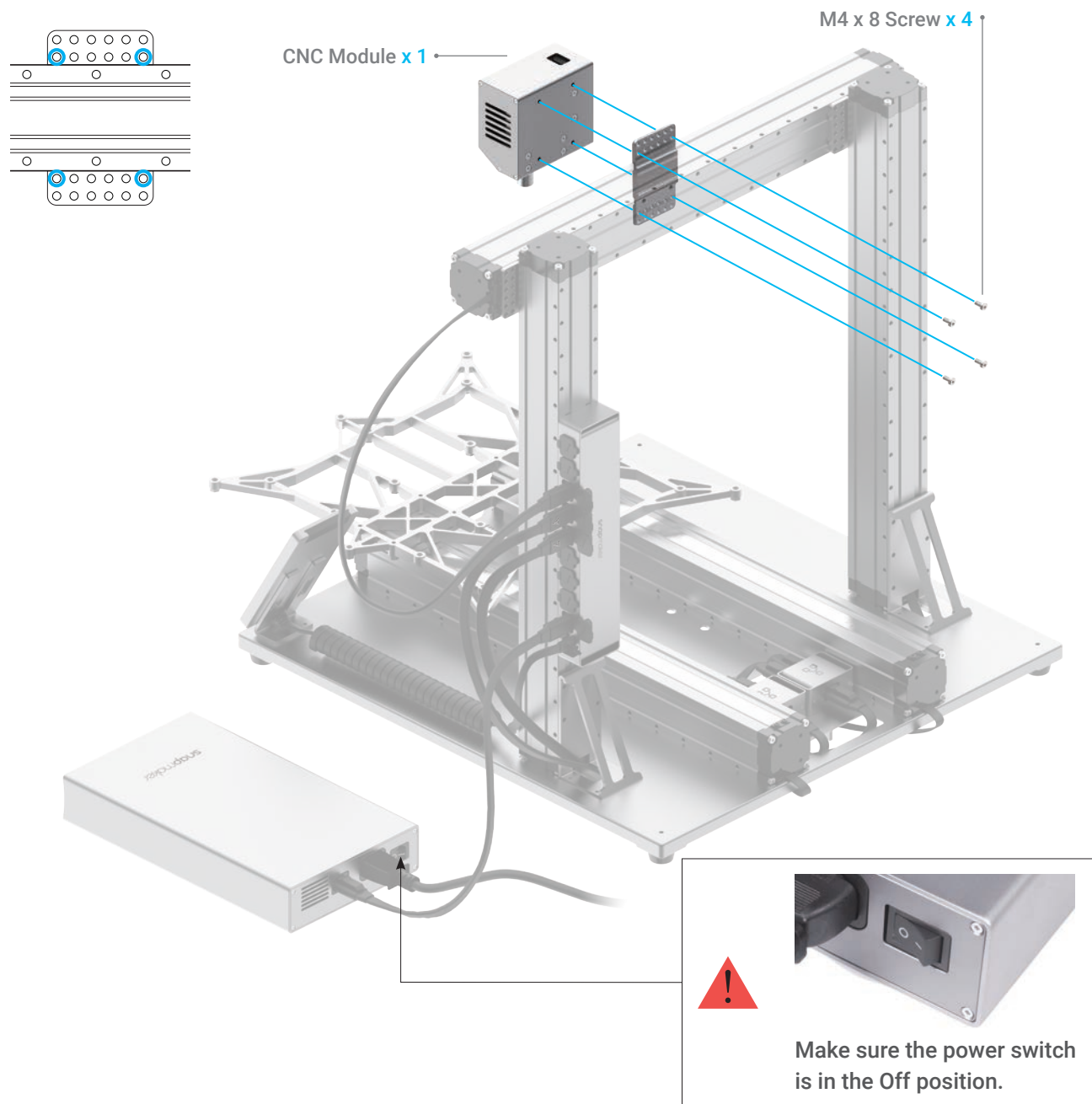

02/04

Connect the CNC Module to the Controller.

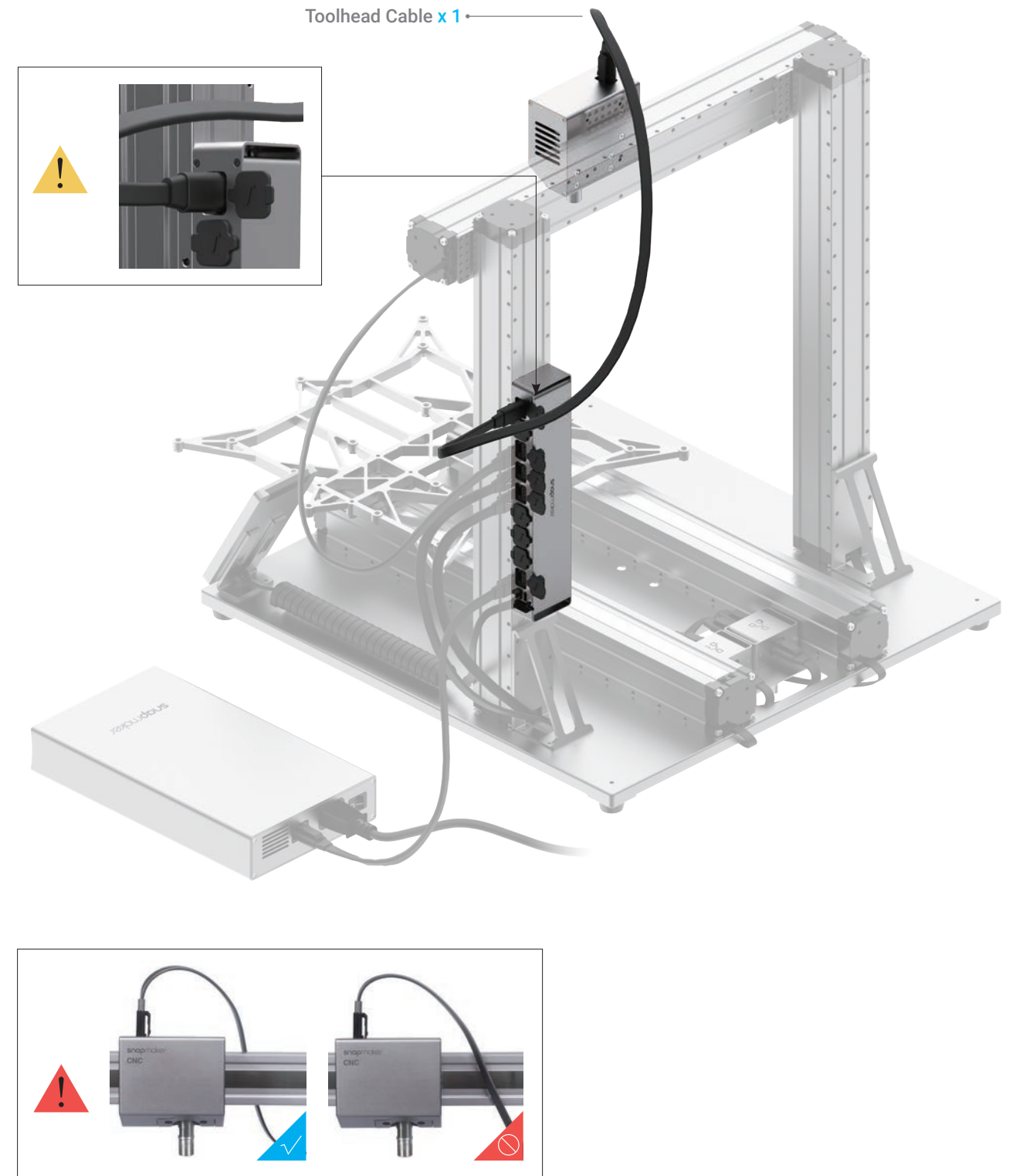

03/04

Attach the CNC Carving Platform to the Platform.

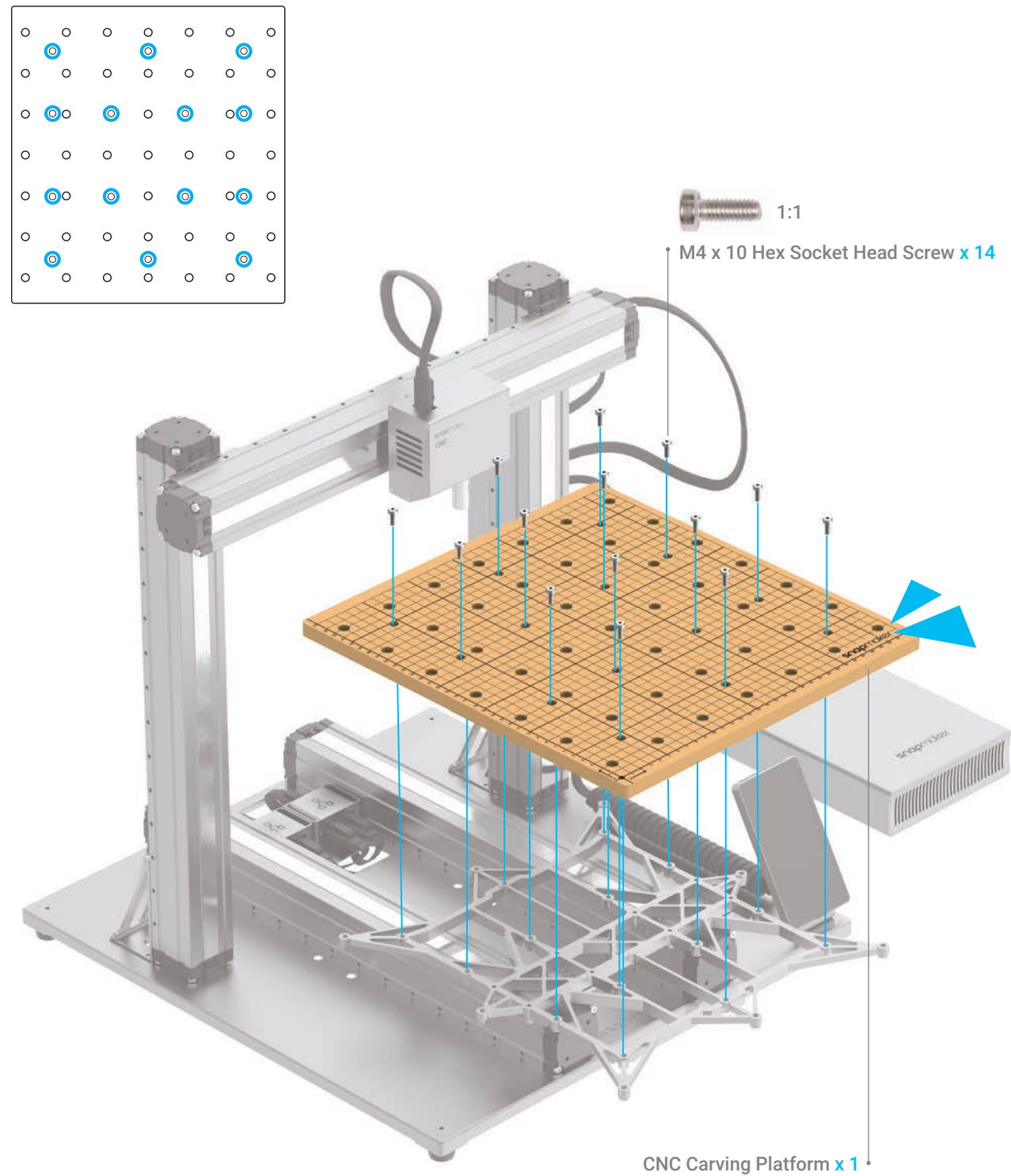

04/04

Attach the Cable Holder to the Z axis, then lock the Toolhead Cable into place.

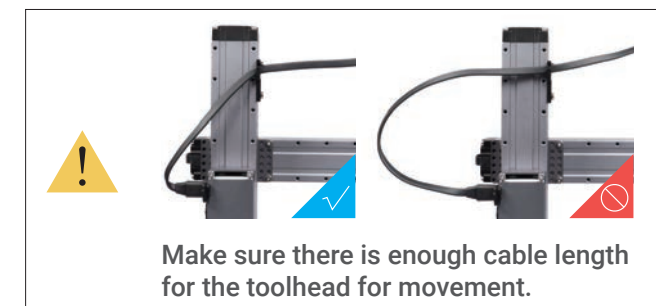
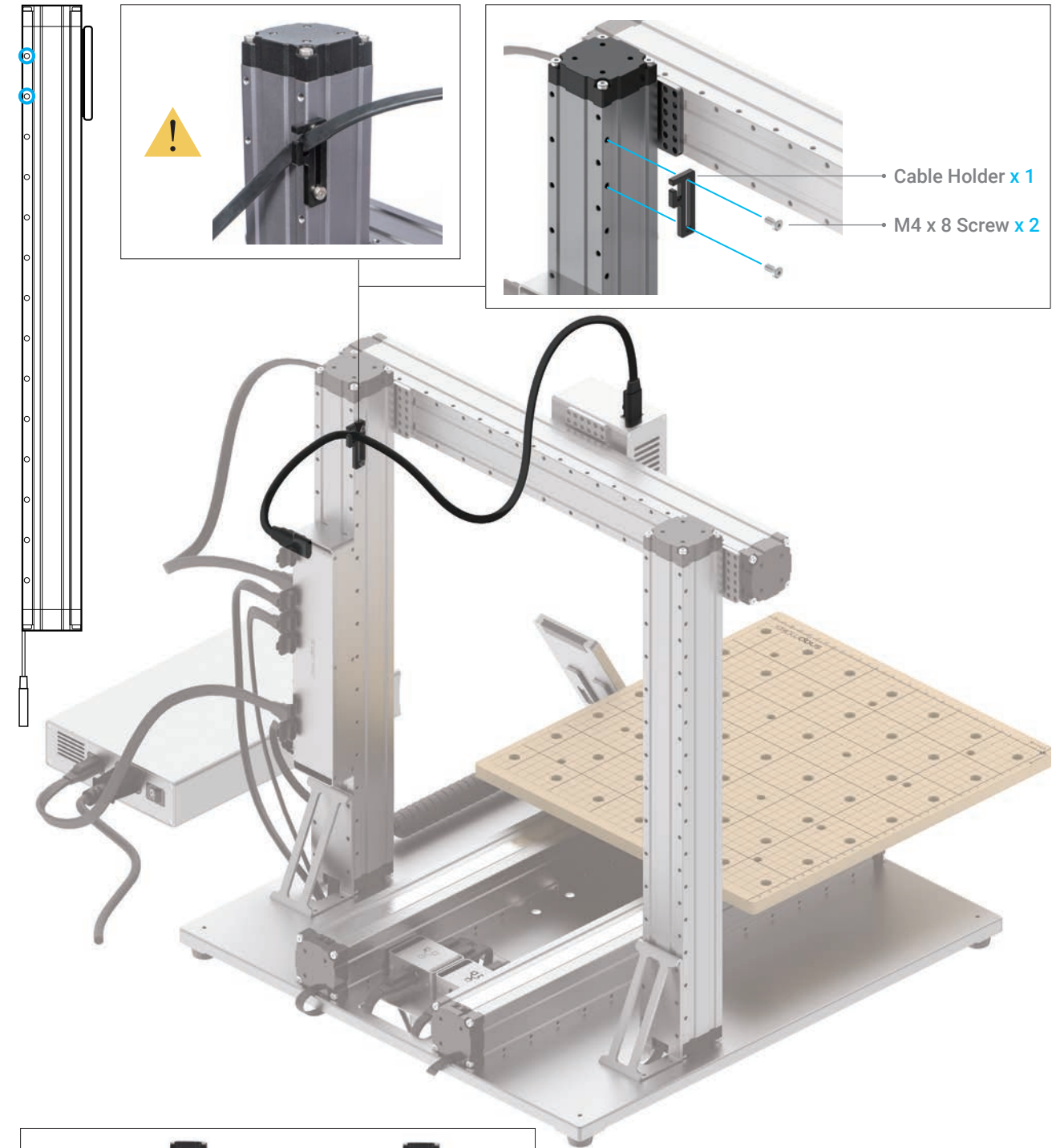

5.1.2 Initial Setup

Guides & Pictures / Snapmaker

Plug the AC Power Cable into an electrical outlet. Switch the power on and follow the prompts on the touchscreen: Read the Terms -> Name the Machine -> Connect to a Wi-Fi Network.



It is recommended to wait for 5 seconds when you turn your machine off and on again.

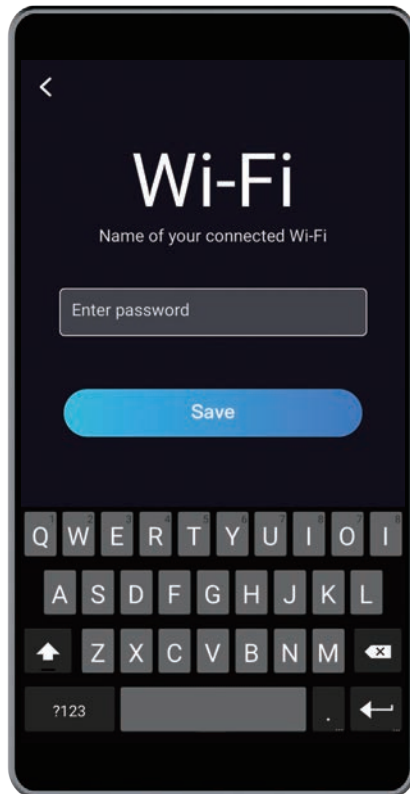

Please skip this step if you have completed the initial setup. If you need to change the settings above, swipe left on the home page of the touchscreen -> select **Settings** -> tap **Wi-Fi** or **About Machine** as needed.



The initial guide, which helps you get started, will appear only once. If you need to launch it again, swipe left on the home page of the touchscreen -> select **Settings** -> tap **Guides**.

5.2.1 Fix the Material

Guides & Pictures / Snapmaker

1. Place the provided material on the center of the CNC carving platform.

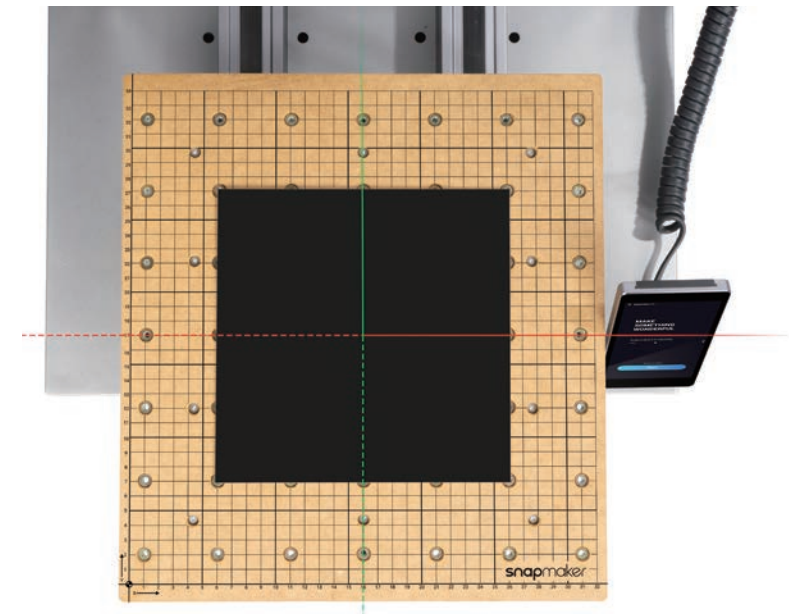

2. Attach the clamp set to the CNC carving platform, then fix the material by screwing the wing nuts.



The size of our provided model is 139.2 x 141.5mm. Make sure the clamp set does not impede the movement of the CNC bit.

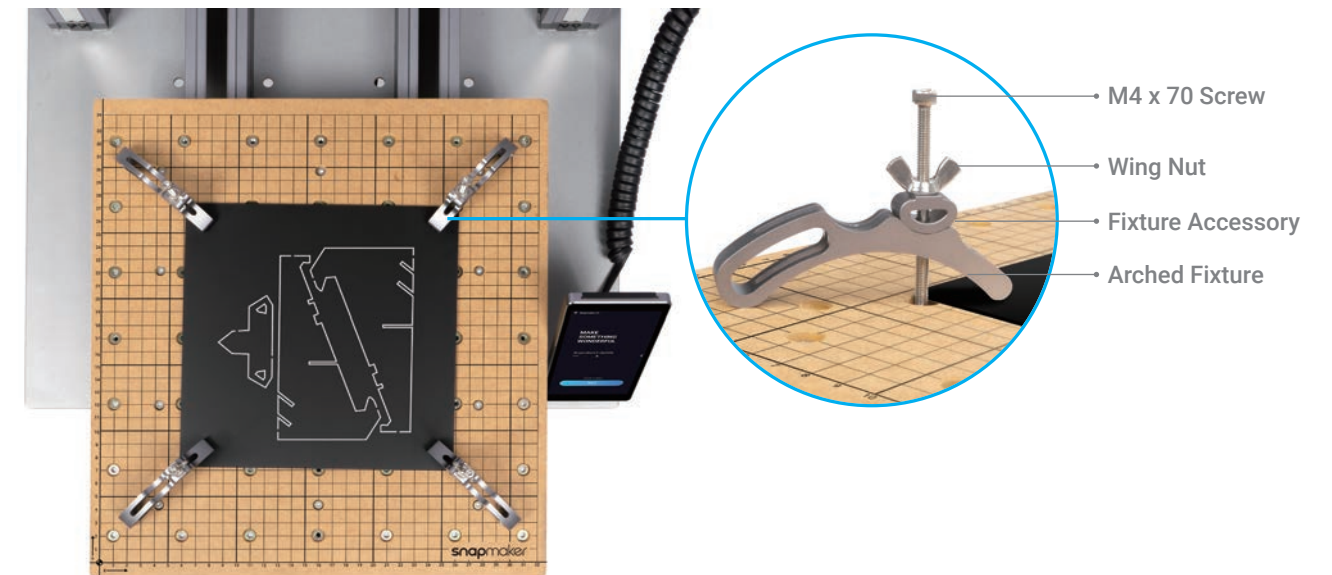



Do not screw the screws through the CNC carving platform.



Make sure the clamp set will not collide with any portions of the machine.

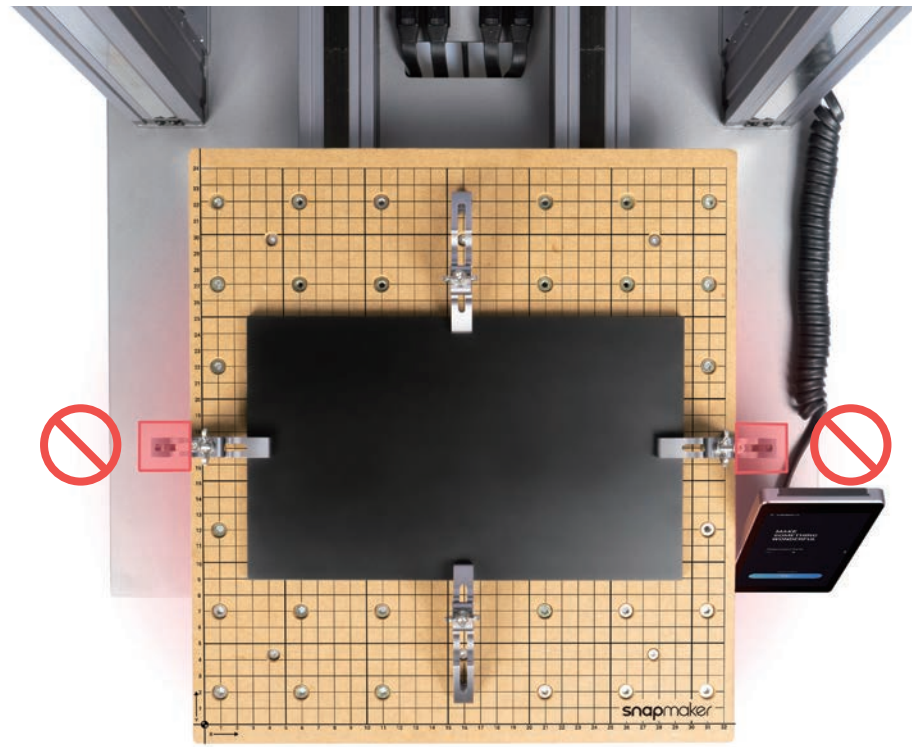

All the three positions as illustrated can be used to fix the material.



5.2.2 Attach the CNC Bit

Guides & Pictures / Snapmaker

How It Works: CNC Bit Usage

Flat End Mill is typically used for slotting or cutting materials into flat surface.

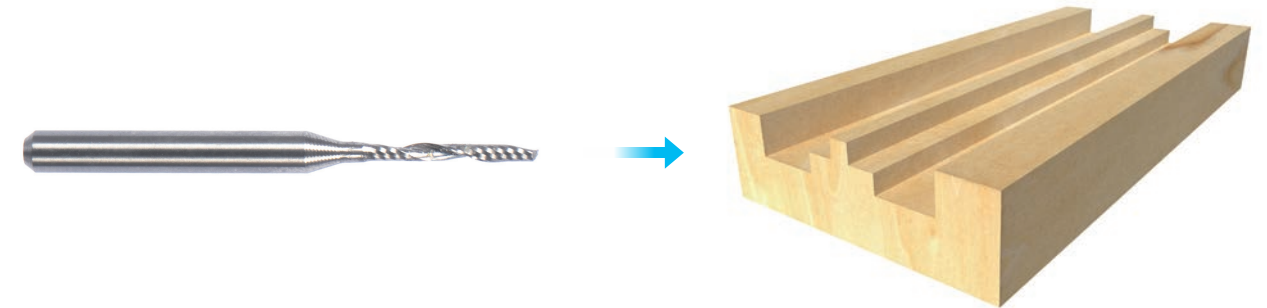

Ball End Mill is typically used for carving materials into curved surface.

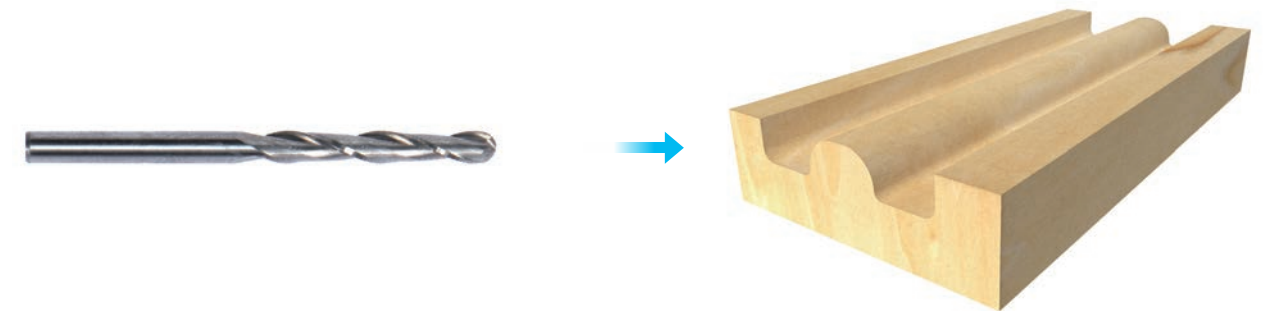

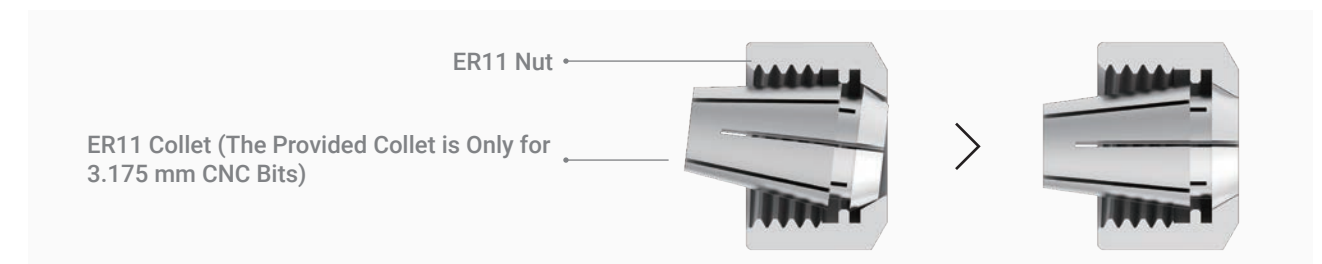

How to Attach the CNC Bit

1. Obliquely insert the ER11 collet into the ER11 nut until it clicks into place.



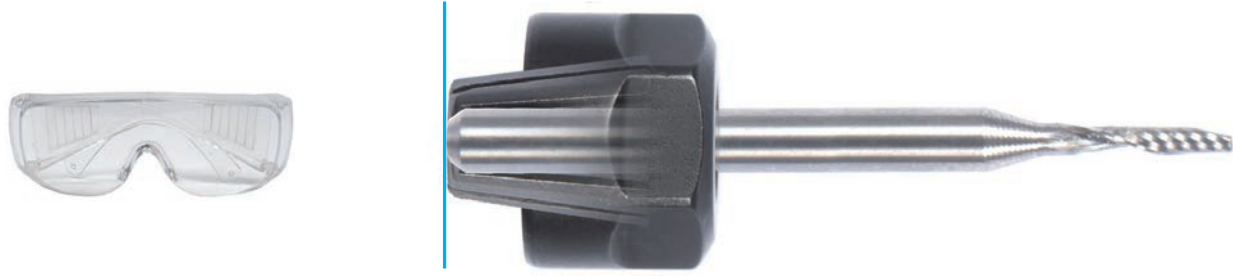

2. Make sure you have worn the CNC Safety Goggles. Insert the CNC bit into the ER11 collet (Flat End Mill is required for our provided model). Make sure the end of the CNC bit is parallel with the edge of the ER11 collet.

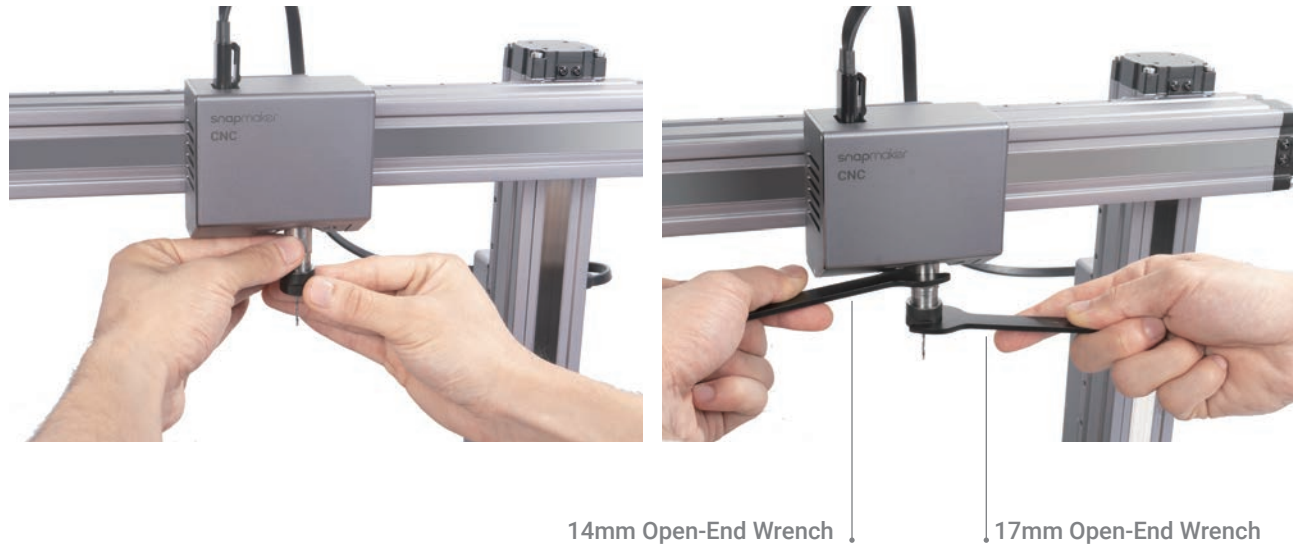

 Handle the CNC bits carefully and keep them out of reach of children.

3. Screw the entire unit onto the shank as tight as possible, then completely tighten the ER11 nut using the open-end wrenches.







Congratulations!

You are now ready to print. Please continue to generate the G-code file.

5.3.1 Prepare the G-code File

Guides & Pictures / Snapmaker

1. Install the Software and Complete the Initial Setup



Download our software Snapmaker Luban at <https://snapmaker.com> and install it. Then connect to a Wi-Fi network: Enter the Workspace  -> Connection -> Select **Wi-Fi** -> Click  -> Select your machine -> Click **Open** -> Tap **Yes** on the touchscreen.

2. Generate the G-code File and Send It to the Machine

① Open the test file from **Case Library** -> ② Click **Process** after configuring the settings in **Configurations** section -> ③ Use the default settings specifically configured for the test file -> ④ Generate the G-code file -> ⑤ Load G-code to **Workspace** -> ⑥ Send G-code to the machine via Wi-Fi.

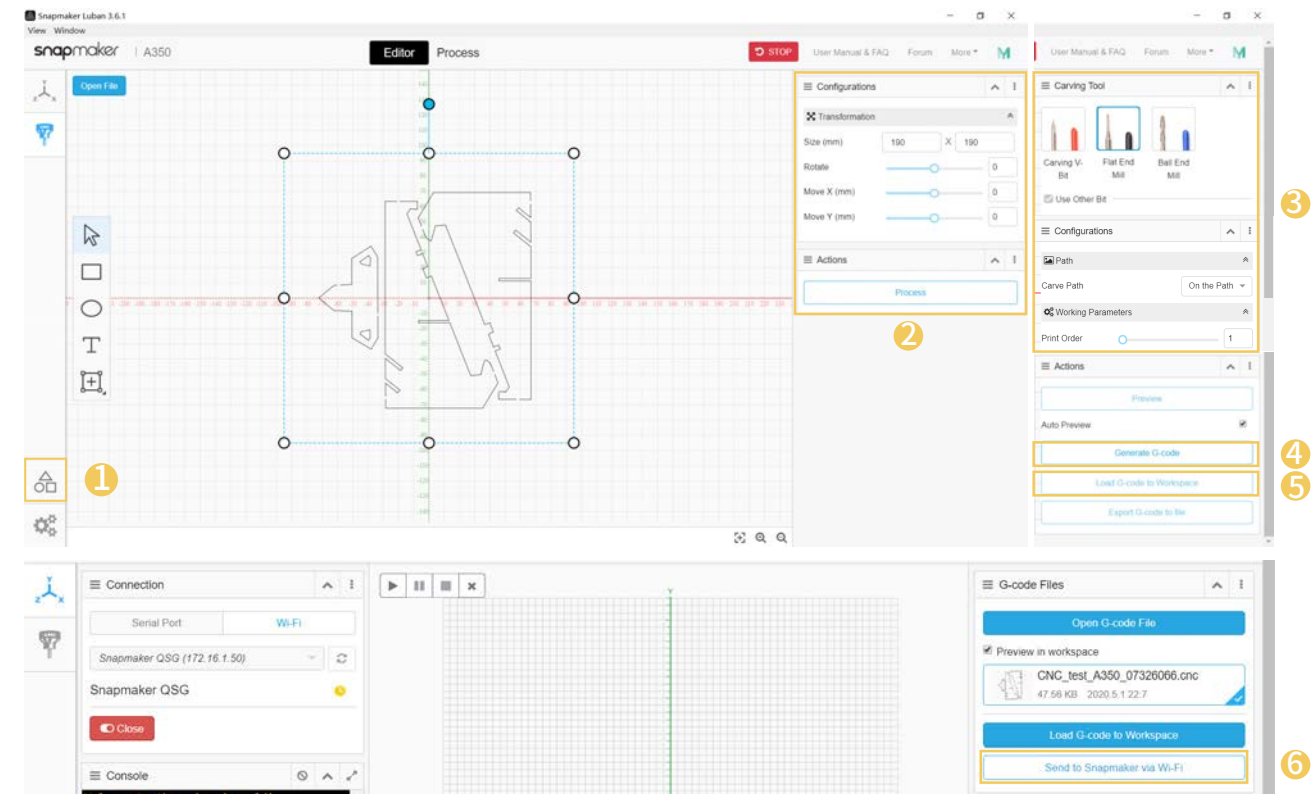
 You can also upload your own files by clicking **Open File in Editor** and configure the file settings.



-  Files sent by Wi-Fi can be found on the touchscreen: **Files > Local**.
-  You can also send the G-code files to the machine via the USB disk. Click **Export G-code to file** in Snapmaker Luban and save it to the USB disk, then insert the USB disk into the controller and select **Files > USB** on the touchscreen.

5.3.2 Set the Work Origin and Start Carving

Guides & Pictures / Snapmaker

How It Works: Work Origin

Find out where the carving will be by setting the work origin. The work origin corresponds to the (0, 0) coordinate origin in the software.

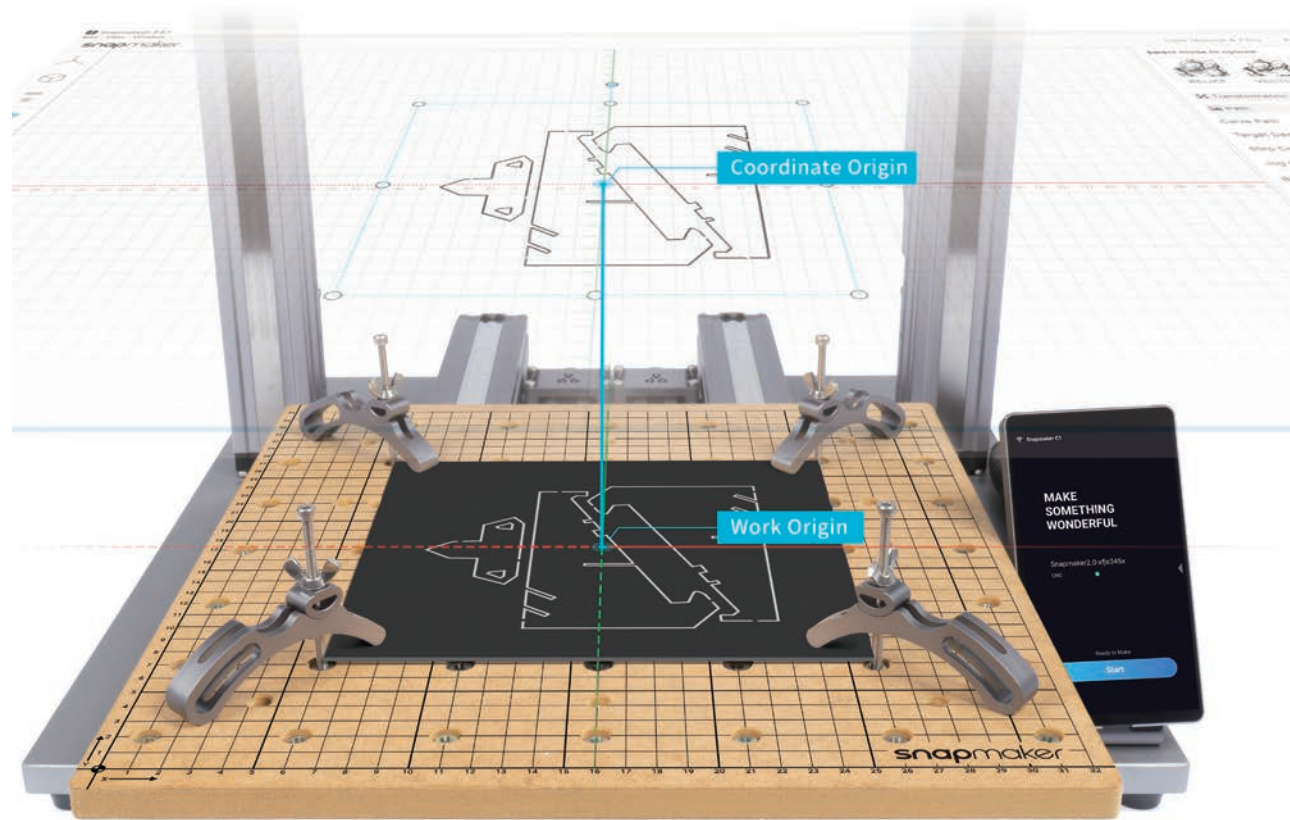

How to Set the Work Origin

1. After receiving the G-code file, tap **Yes** and **Next** on the touchscreen to enter the **Set Work Origin** screen.

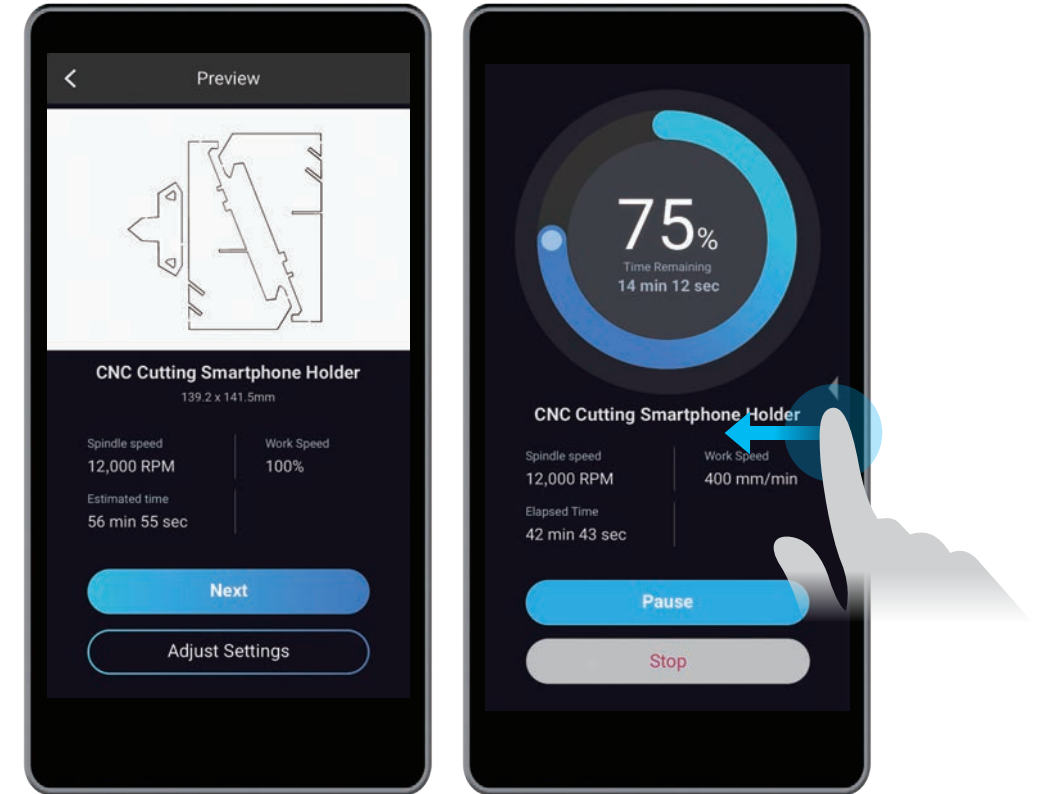

If you need to adjust settings, you can either tap **Adjust Settings** on the **Preview** screen or swipe left on the carving progress screen.

2. Tap **X-/X+/Y-/Y+/Z-/Z+** to move the CNC bit to where the work origin will be (In this case, we set the center of the image as the coordinate origin in the software). Now the CNC bit should be about 5 mm away from the material.

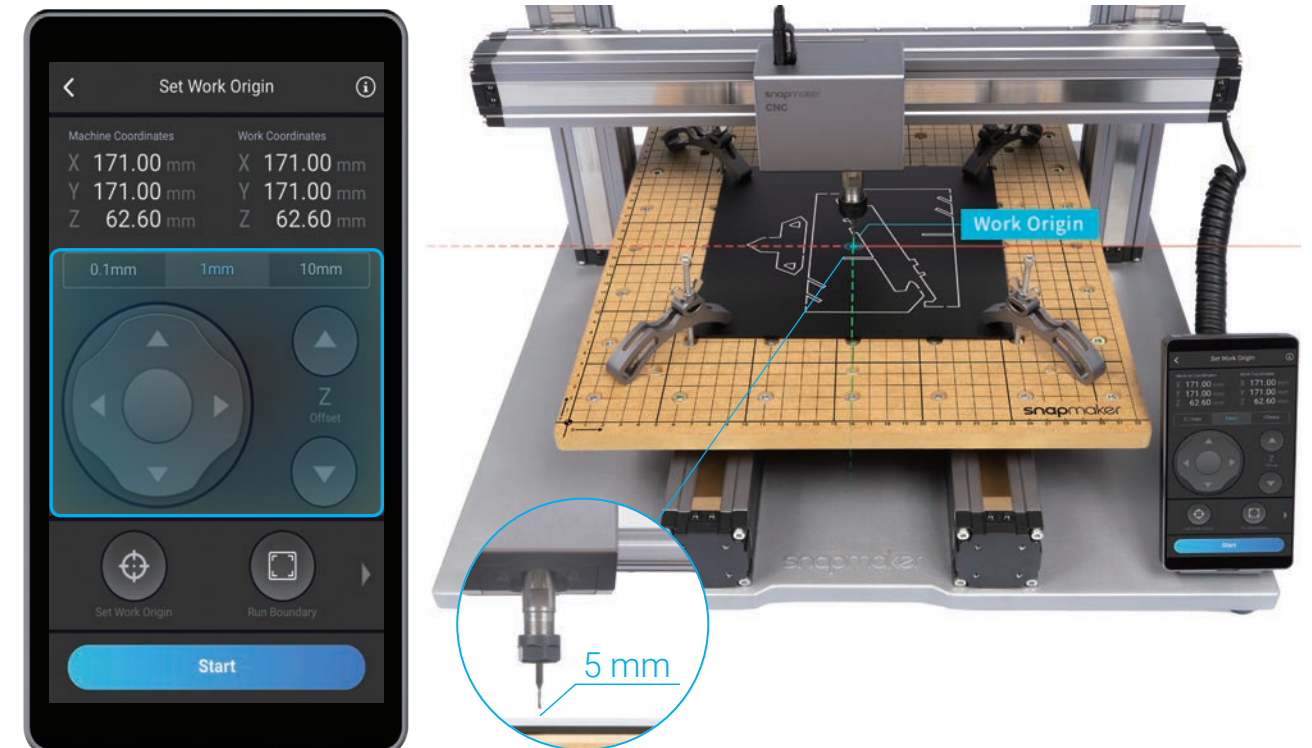

3. Place the calibration card or a piece of A4 paper between the CNC bit and the material. Keep adjusting the height of the CNC bit using **Z-/Z+** buttons until there is slight resistance when you pull out the calibration card, and it should be wrinkled when you push it forward. Tap **Set Work Origin**.

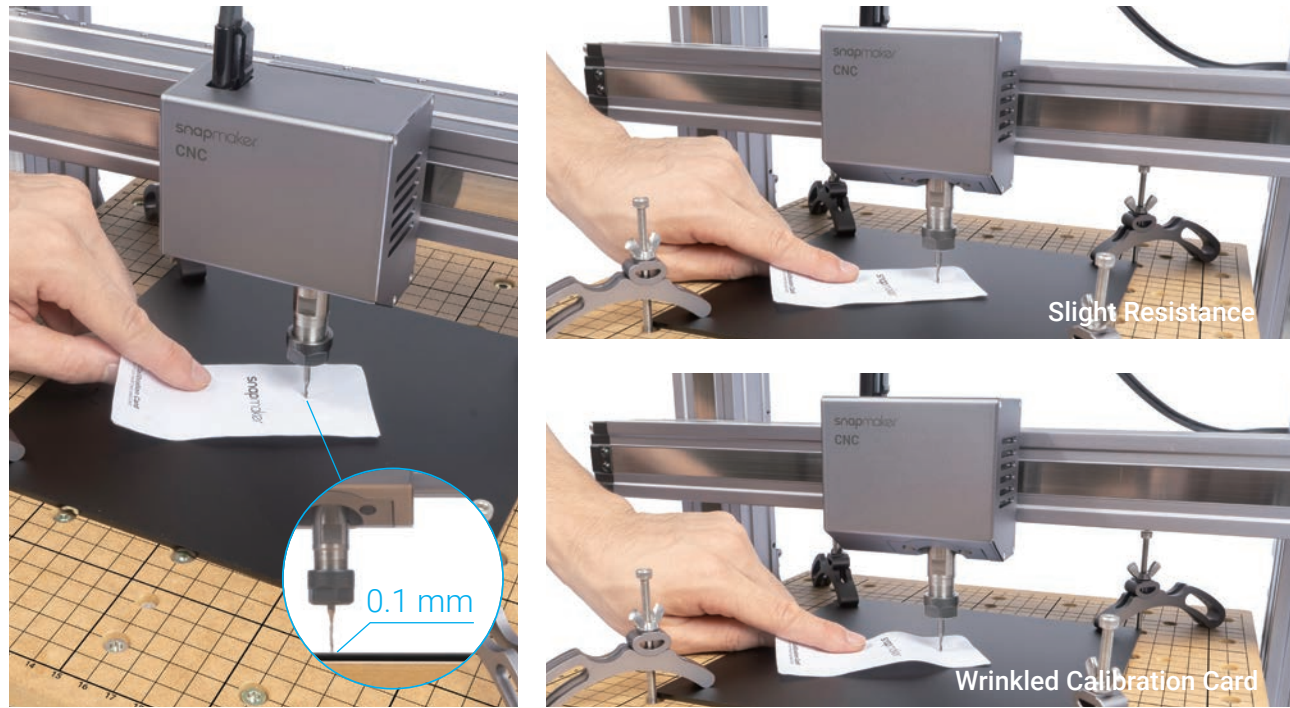

4. Tap **Z+** to lift the CNC bit until it is above the clamp set, then tap **Run Boundary** to check if the work origin is proper. If part of the boundary runs beyond the material or the CNC bit runs into any portions of the machine, reset the work origin and run boundary again.

 If you have run boundary with the CNC bit above the clamp set, you can lower the CNC bit to run boundary again as you need.

 If the CNC bit runs into any portions of the machine, power off the machine immediately and check if the CNC bit is damaged. Change the CNC bit if it is damaged.

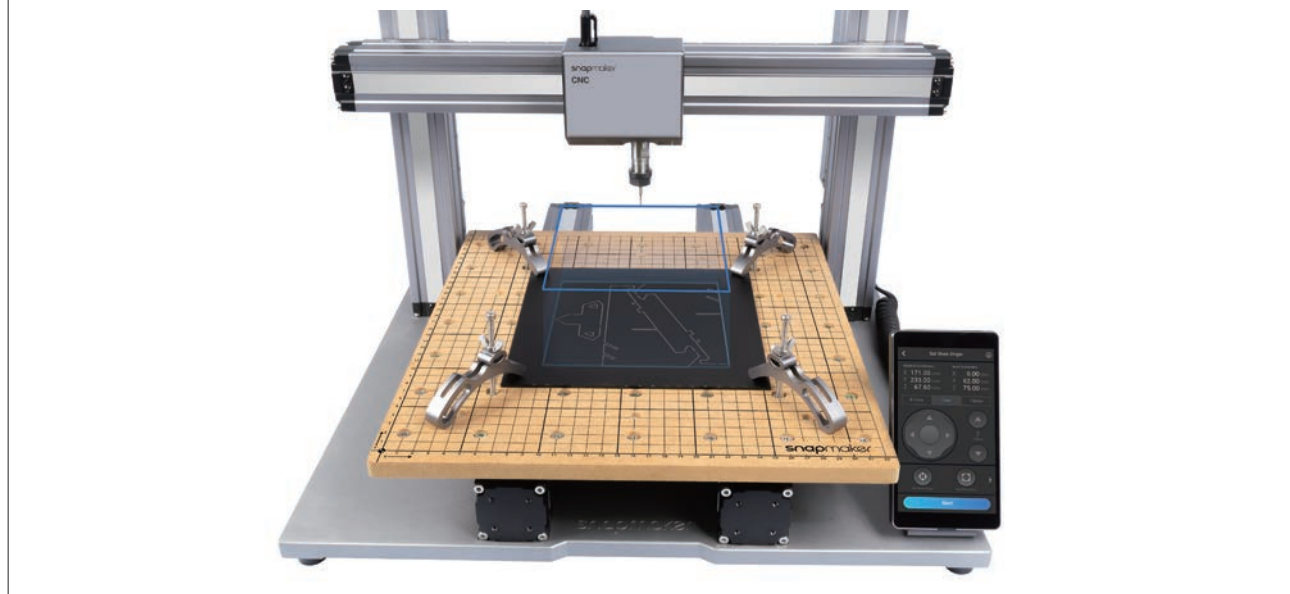

5. Tap **Start** to start carving.

5.3.3 Clean the Finished Work and the Machine

Guides & Pictures / Snapmaker

1. Remove the clamp set from the CNC carving platform.



2. Clean the finished work and the machine using the dust collector, then remove the finished work using the Diagonal Pliers and complete the assembly.

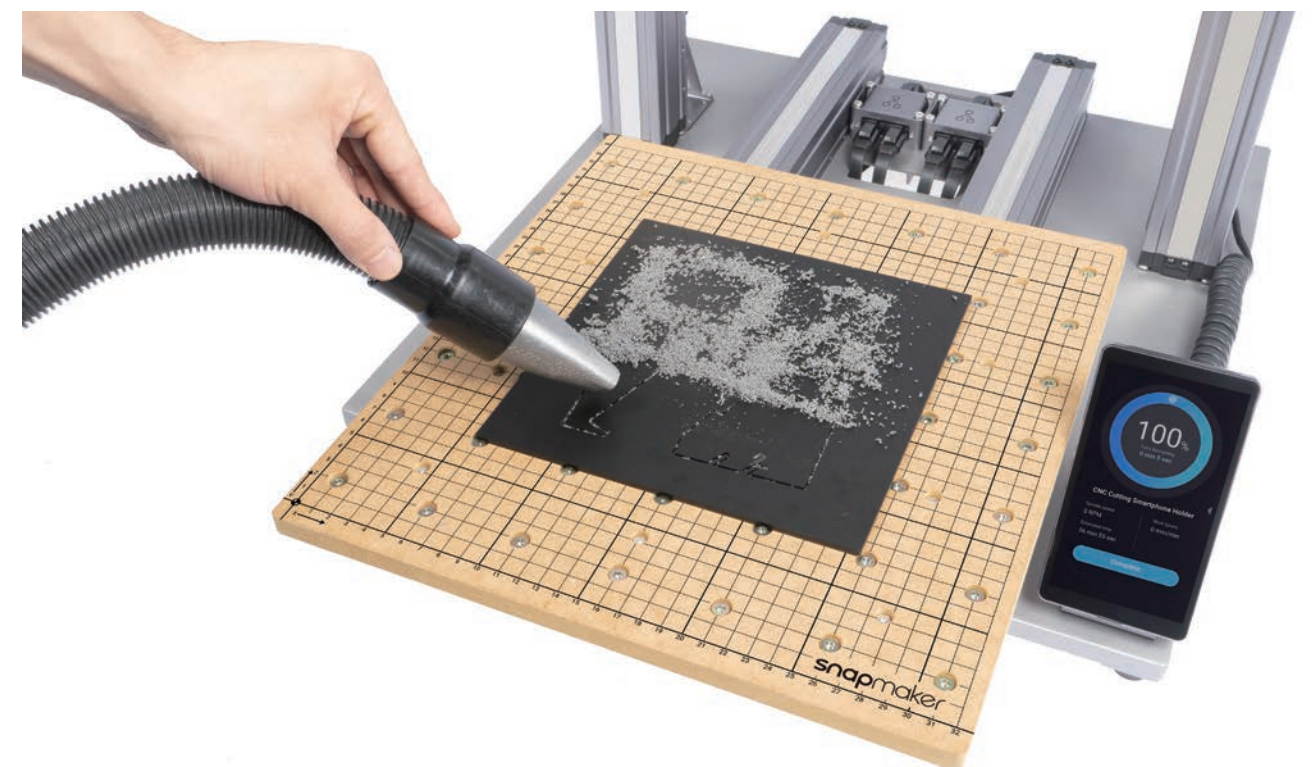

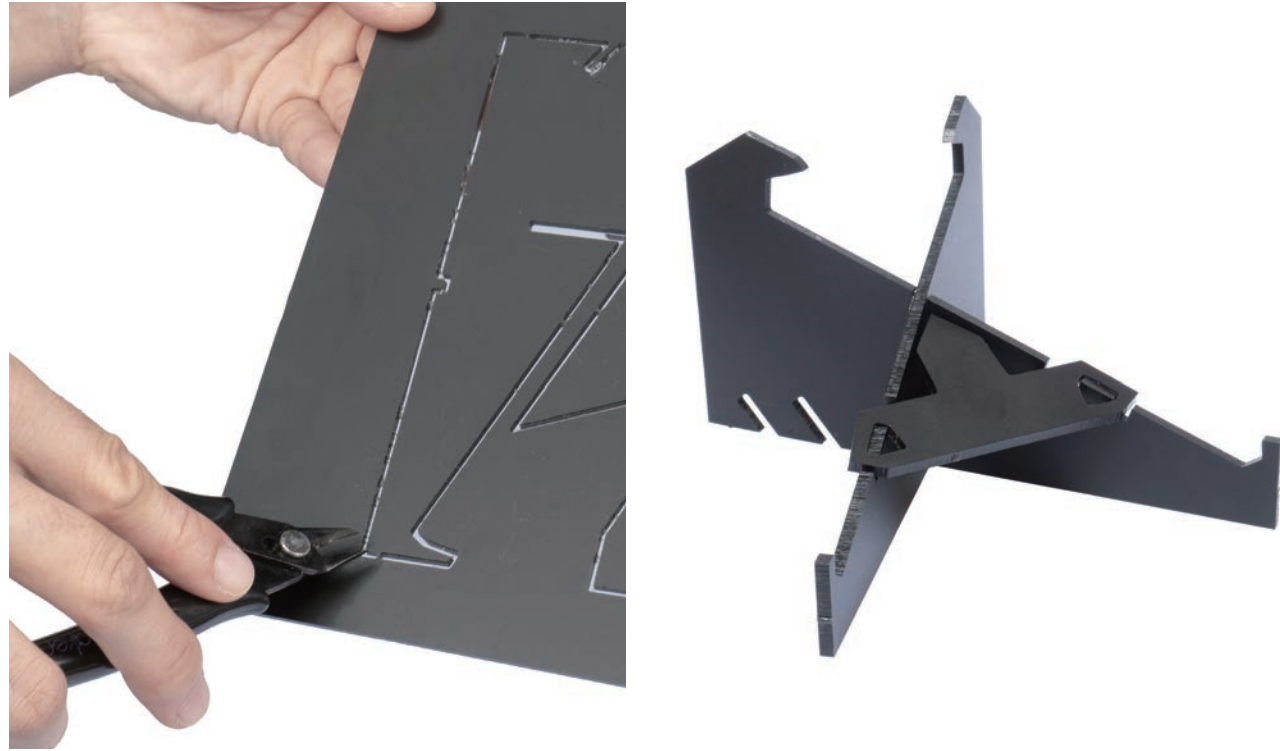

Resources

This guide is subject to change. For the latest version, go to:
<https://snapmaker.com>

Besides this guide, there is also a User Manual available on our website:
<https://snapmaker.com>

We are here for you whenever you need general information or technical support:
support@snapmaker.com

For any sales inquiries, you can reach out to us at:
sales@snapmaker.com

You can purchase products in our official online store:
<https://shop.snapmaker.com>

Share anything you want with other Snapmaker users at our forum:
<https://forum.snapmaker.com>



Share!

You can share your finished work in our Facebook group and our forum.

