



MODULAR ORDER PICKER CART

Modular Order Picker Carts (OPCM) expand working area, storage capacity, and operator safety for order picker trucks. They also support high-volume material handling at ground level, thanks to heavy-duty phenolic casters. Bolt-on components provide quick configuration, so you can use one cart for stocking, picking, overhead maintenance, and more.

Built for On-the-Fly Customization

Add or remove shelves. Set custom shelf heights. Choose handrails, operator guarding, anti-skid tape, or branding elements like colors and laser-cut logos. Platforms match truck deck height to eliminate tripping hazards, while universal fork pockets and optional adjustable guides ensure seamless compatibility.



Configurable to Task

Bolt-together construction and many optional components allow you to reconfigure the OPCM as your needs evolve.



Optimized for Order Picker Trucks

Open fork pockets fit all common forks. Factory-set base heights eliminate deck gaps. Lightweight design maximizes lift truck capacity.



High Capacity

Optional adjustable shelves carry up to 300 lb each, and can be entirely removed for steel-pallet functionality. The platform features a total capacity of 2,000 lb.



Designed and Built in the USA

BHS engineers, manufactures, and ships every OPCM at our state-of-the-art facility in St. Louis, Missouri.

CONTACT THE BHS SALES TEAM FOR MORE INFORMATION ABOUT THIS PRODUCT

Flip sheet over to learn more about this warehouse solution.



1.800.BHS.9500



BHS1.com

STOCK CARTS

MODULAR ORDER PICKER CART

Modular Design

Modularity supports multiple common use cases. Components can be added, removed, or reconfigured as your operation's needs change.

300 LB CAPACITY

Permanent Capacity Labeling

Laser-cut labeling on optional shelves gives a clear, permanent reference. Each shelf has a 300 lb (136 kg) load capacity.

Flush Platform Alignment

Platform is sized to eliminate tripping hazards on order picker trucks

Platform Attachment

Open fork pockets are compatible with most types of order pickers. For a tighter fit, the Adjustable Fork Guides option is available.

Heavy Duty Construction

Light-weight, high-strength steel construction optimizes capacity for fork trucks



Adjustable Shelves

Optional bolt-on shelves adjust to required height. Shelf heights can be adjusted in 3" increments from 15" above the deck to 57" high. Shelves are available in 24", 30", 36", or 42" depths.

Streamline Order Fulfillment

The OPCM is commonly used as an order picker fork attachment and a manual cart in one



Mobility

Phenolic casters – 2 swivel casters with brakes and 2 rigid casters for easy maneuverability

OPCM-4248 pictured with optional Shelves, Fork Pockets, and Anti-Skid Tape

Customizable

Choose from a variety of options to tailor this cart to your specifications. Custom designs are available on request.



Model Specifications

MODEL	WIDTH	DEPTH	PLATFORM HEIGHT	PLATFORM CAPACITY	WEIGHT
OPCM-4042	40" (1016 mm)	42" (1067 mm)	9.9" (252 mm)	2,000 lb (907 kg)	85 lb (39 kg)
OPCM-4048		48" (1219 mm)			100 lb (45 kg)
OPCM-4060		60" (1524 mm)			130 lb (59 kg)
OPCM-4242	42" (1067 mm)	42" (1067 mm)			90 lb (41 kg)
OPCM-4248		48" (1219 mm)			105 lb (48 kg)
OPCM-4260		60" (1524 mm)			135 lb (61 kg)
OPCM-4842	48" (1219 mm)	42" (1067 mm)			105 lb (48 kg)
OPCM-4848		48" (1219 mm)			120 lb (54 kg)
OPCM-4860		60" (1524 mm)			140 lb (64 kg)
OPCM-6042	60" (1524 mm)	42" (1067 mm)			120 lb (54 kg)
OPCM-6048		48" (1219 mm)			135 lb (61 kg)
OPCM-6060		60" (1524 mm)			155 lb (70 kg)



OPCM-4248 pictured with optional Fork Pockets (OPCM-FP)

Modular Options

Bolt-on options provide the flexibility to add at the time of order, after, or reconfigure as needs change.



Fork Pockets (OPCM-FP)

Open fork pockets enable proper attachment of the cart to the order picker truck. Maximum outside of fork width is 30". Consult factory to ensure correct size is ordered.



Adjustable Fork Guides (OPCM-FP-GUIDE)

Bolt-in, galvanized panels reduce outside fork pocket dimension to 27", 25", or 23" depending on installation position, creating a tighter fit within fork pocket compartment for any lift truck.



Shelf Kit (OPCM-1TIER/2TIER/3TIER)

Add one, two, or three shelves, available in 24", 30", 36", or 42" depths. Each shelf features a 300 lb capacity, and adjusts in 3" height increments. OPCM can ship with shelves installed at desired heights if identified at time of order.



Guarding (OPCM-GRD/GRDS)

Slotted steel guarding helps keep the load contained, running the depth of the shelves and along the rear. Guarding is also available for models without shelves – identify depth at time of order (24", 30", 36", or 42").

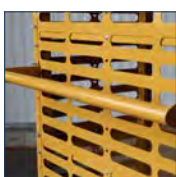

Handle (OPCM-HDL)

Available for configurations with shelves. Ergonomically maneuver cart by hand with a handle that bolts to rear of shelving or guarding.



Push Handle (OPCM-PUSH)

Available for configurations without shelves. Ergonomically maneuver cart by hand with a bolt-on push handle. Adds 31.6" height to cart.



Handrails (OPCM-HR)

Available for configurations without shelves. Bolt-on steel handrails run entire depth and along back of deck. Includes kick plate and six safety harness attachment points. Adds 47.7" height to cart.

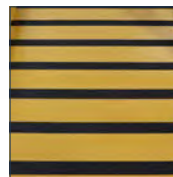

Anti-Skid Tape (SKIDTAPE)

Textured tape on the platform deck adds traction.



Custom Lasered Logo (OPCM-LOGO)

Add a laser-cut logo plate to the rear of the cart to incorporate your company's branding.

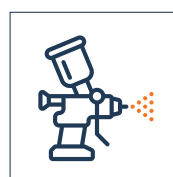

Custom Color

BHS Yellow is the standard powder-coat paint color for visibility in warehouses, however customers may choose from other colors. For more details, visit <https://na.bhs1.com/custom-colors>

Sample Configurations



OPCM-4248 with optional Fork Pockets (OPCM-FP)



OPCM-4248 with optional Fork Pockets(OPCM-FP), Push Handle (OPCM-PUSH), and Anti-Skid Tape (SKIDTAPE)



OPCM-4248 with optional Fork Pockets (OPCM-FP), Three 24" Deep Shelf Kit (OPCM-3TIER-24D), and Anti-Skid Tape (SKIDTAPE)



OPCM-4248 with optional Fork Pockets (OPCM-FP), Handrails (OPCM-HR), Anti-Skid Tape (SKIDTAPE)



OPCM-4248 with optional Fork Pockets (OPCM-FP), Adjustable Fork Pocket Guides (OPCM-FP-GUIDE), Three 24" Deep Shelf Kit (OPCM-3TIER-24D), Guarding (OPCM-GRDS-24D), Handle (OPCM-HDL), and Anti-Skid Tape (SKIDTAPE)

Modular Order Picker Carts & Platforms

Dealer Information

Company Name: _____
 Contact Name: _____
 Address: _____
 City, State, & Zip: _____
 Phone: _____
 Email: _____

End User Information

Company Name: _____
 Contact Name: _____
 Address: _____
 City, State, & Zip: _____
 Phone: _____
 Email: _____

Platform Width (W)

40" 42" 48" 60" Custom: _____

Platform Length (L)

42" 48" 60" Custom: _____

Casters

Yes No

Number of Shelves

0 1 2 3 4

Shelf Depth (measured from rear of platform)

N/A 24" 30" 36" 42"

Select a Shelf Height for Each Shelf (measured from platform)

<input type="checkbox"/> N/A	<input type="checkbox"/> 24"	<input type="checkbox"/> 36"	<input type="checkbox"/> 48"
<input type="checkbox"/> 15"	<input type="checkbox"/> 27"	<input type="checkbox"/> 39"	<input type="checkbox"/> 51"
<input type="checkbox"/> 18"	<input type="checkbox"/> 30"	<input type="checkbox"/> 42"	<input type="checkbox"/> 54"
<input type="checkbox"/> 21"	<input type="checkbox"/> 33"	<input type="checkbox"/> 45"	<input type="checkbox"/> 57"

Optional 3-Sided Guarding Depth (measured from rear of platform)

N/A 24" 30" 36" 42"

Fork Pockets (required on models without casters)

No
 Yes (if selected, identify A & B dimensions as identified in figure)
 (A) Vertical offset between operator platform & top of fork: _____
 (B) Maximum overall width of forks: _____

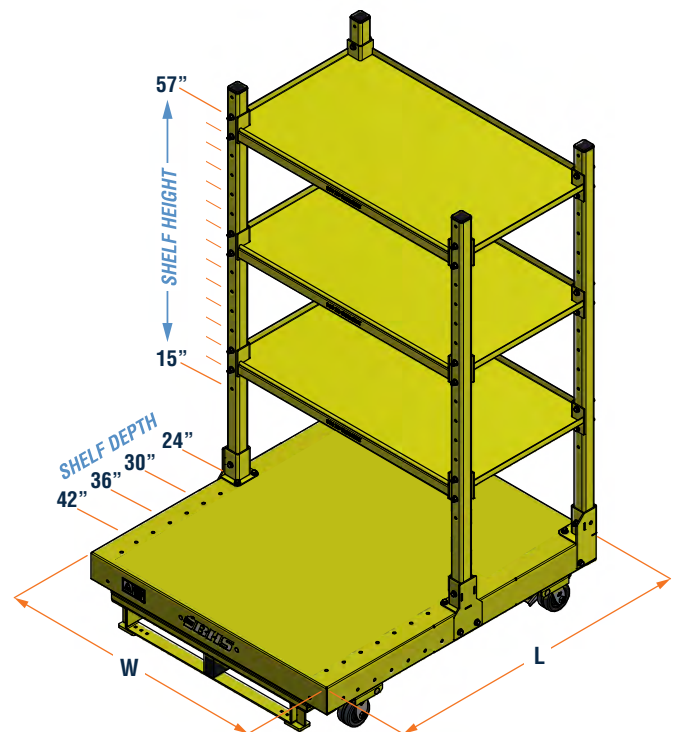
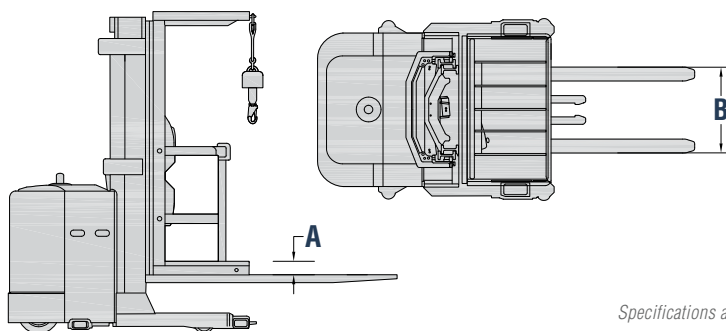

Additional Options

Handle
 For model with shelves (OPCM-HDL)
 For model without shelves (OPCM-PUSH)
 Handrails for models without shelves (OPCM-HR)
 Adjustable Fork Guides (OPCM-FP-GUIDE)
 Anti-Skid Tape (SKIDTAPE)
 Custom Lasered Logo (OPCM-LOGO)
 Custom Color: _____

Notes