



## **MODULAR ORDER PICKER PLATFORM**

Modular Order Picker Platforms feature bolt-on components that ensure you always have the right tool for the job — even if the job changes. Custom-height bases provide a seamless extension for operator platforms, eliminating trip hazards, while adjustable shelves maximize storage.

### **Modular Design for Task-Based Optimization**

Optional features include handrails, operator guarding, anti-skid tape, custom colors, and laser-cut logos. Open fork pockets work with virtually any order picker, while optional fork guides adjust for custom fits. Strip the unit down for a sturdy steel pallet, or bolt on options to optimize order picking, putaway, overhead work, and more.



#### **Versatile Performance**

Change shelf heights, add guarding, or remove everything for a simple platform attachment.



#### **Endless Adjustability**

Future-proof your fleet with a versatile platform attachment that adapts to meet evolving needs.



#### **Redundant Safety Features**

Add anti-skid tape to the platform, rails to open edges, and guarding to shelf exteriors. Match the safety profile to specific tasks.



#### **Designed and Built in the USA**

All BHS products are engineered and manufactured in our state-of-the-art facility in St. Louis, Missouri.

**CONTACT THE BHS SALES TEAM FOR MORE INFORMATION ABOUT THIS PRODUCT**

Flip sheet over to learn more about this warehouse solution.

1.800.BHS.9500

[BHS1.com](http://BHS1.com)

## WORK PLATFORMS

# MODULAR ORDER PICKER PLATFORM

### Improved Workflow

Expand working and storage areas for order picker trucks

### Modular Design

Modularity supports a variety of common use cases. Adjustable components provide versatile service.

### Flush Platform Alignment

Platform is sized to eliminate tripping hazards on order picker trucks

### Heavy Duty Construction

Light-weight, high-strength steel construction optimizes capacity for fork trucks

### Customizable

Tailor this platform to your specifications by choosing from a variety of options including operator guarding, shelving, and even add your branding. Custom designs are available on request.

### Optional Handrails

Transform the platform with bolt-on steel handrails featuring a kickplate

### Platform Attachment

Open fork pockets are compatible with most types of order pickers. For a tighter fit, the Adjustable Fork Guides option is available.



OPPM-4248 pictured with Fork Pockets, and optional Handrails and Anti-Skid Tape

## Model Specifications

MODEL	WIDTH	DEPTH	PLATFORM HEIGHT	PLATFORM CAPACITY	WEIGHT
OPPM-4042	40" (1016 mm)	42" (1067 mm)	4.7" (119 mm)	2,000 lb (907 kg)	85 lb (39 kg)
OPPM-4048		48" (1219 mm)			100 lb (45 kg)
OPPM-4060		60" (1524 mm)			130 lb (59 kg)
OPPM-4242	42" (1067 mm)	42" (1067 mm)			90 lb (41 kg)
OPPM-4248		48" (1219 mm)			105 lb (48 kg)
OPPM-4260		60" (1524 mm)			135 lb (61 kg)
OPPM-4842	48" (1219 mm)	42" (1067 mm)			105 lb (48 kg)
OPPM-4848		48" (1219 mm)			120 lb (54 kg)
OPPM-4860		60" (1524 mm)			140 lb (64 kg)
OPPM-6042	60" (1524 mm)	42" (1067 mm)			120 lb (54 kg)
OPPM-6048		48" (1219 mm)			135 lb (61 kg)
OPPM-6060		60" (1524 mm)			155 lb (70 kg)

### Notes:

- When ordering, identify the vertical offset between operator platform and top of fork. This allows the factory to size the platform to sit flush with the operator's platform. See last page, diagram A. Overall Height will vary depending upon dimension supplied.
- Overall dimensions may vary depending upon modular options.

# Modular Options

Bolt-on options provide the flexibility to add at the time of order, after, or reconfigure as needs change.



## Fork Pockets (OPCM-FP) *REQUIRED*

Open fork pockets enable proper attachment of the platform to the order picker truck. Maximum outside of fork width is 30". *Consult factory to ensure correct size is ordered.*



## Adjustable Fork Guides (OPCM-FP-GUIDE)

Bolt-in, galvanized panels reduce outside fork pocket dimension to 27", 25", or 23" depending on installation position, creating a tighter fit within fork pocket compartment for any lift truck.



## Shelf Kit (OPCM-1TIER/2TIER/3TIER)

Add one, two, or three shelves, available in 24", 30", 36", or 42" depths. Each shelf features a 300 lb capacity, and adjusts in 3" height increments. *OPPM can ship with shelves installed at desired heights if identified at time of order.*

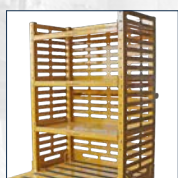

## Guarding (OPCM-GRD/GRDS)

Slotted steel guarding helps keep the load contained, running the depth of the shelves and along the rear. Guarding is also available for models without shelves – *identify depth at time of order (24", 30", 36", or 42").*



## Handrails (OPCM-HR)

*Available for configurations without shelves.* Bolt-on steel handrails run entire depth and along back of deck. Includes kick plate and six safety harness attachment points. Adds 47.7" height to platform.

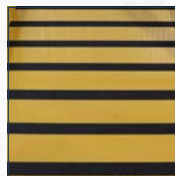

## Anti-Skid Tape (SKIDTAPE)

Textured tape on the platform deck adds traction.



## Custom Lasered Logo (OPCM-LOGO)

Add a laser-cut logo plate to the rear of the platform to incorporate your company's branding.



## Custom Color

*BHS Yellow* is the standard powder-coat paint color for visibility in warehouses, however customers may choose from other colors. For more details, visit <https://na.bhs1.com/custom-colors>

# Sample Configurations

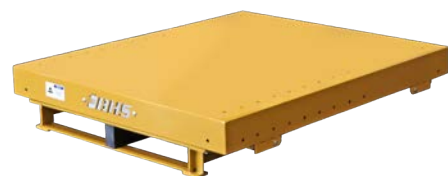

**OPPM-4248** with Fork Pockets (OPCM-FP)



**OPPM-4248** with Fork Pockets (OPCM-FP) and options: Handrails (OPCM-HR) and Anti-Skid Tape (SKIDTAPE)



**OPPM-4248** with Fork Pockets (OPCM-FP) and options: Three 24" Deep Shelf Kit (OPCM-3TIER-24D), and Anti-Skid Tape (SKIDTAPE)

# Modular Order Picker Carts & Platforms

## Dealer Information

Company Name: \_\_\_\_\_  
 Contact Name: \_\_\_\_\_  
 Address: \_\_\_\_\_  
 City, State, & Zip: \_\_\_\_\_  
 Phone: \_\_\_\_\_  
 Email: \_\_\_\_\_

## End User Information

Company Name: \_\_\_\_\_  
 Contact Name: \_\_\_\_\_  
 Address: \_\_\_\_\_  
 City, State, & Zip: \_\_\_\_\_  
 Phone: \_\_\_\_\_  
 Email: \_\_\_\_\_

### Platform Width (W)

40"  42"  48"  60"  Custom: \_\_\_\_\_

### Platform Length (L)

42"  48"  60"  Custom: \_\_\_\_\_

### Casters

Yes  No

### Number of Shelves

0  1  2  3  4

### Shelf Depth (measured from rear of platform)

N/A  24"  30"  36"  42"

### Select a Shelf Height for Each Shelf (measured from platform)

<input type="checkbox"/> N/A	<input type="checkbox"/> 24"	<input type="checkbox"/> 36"	<input type="checkbox"/> 48"
<input type="checkbox"/> 15"	<input type="checkbox"/> 27"	<input type="checkbox"/> 39"	<input type="checkbox"/> 51"
<input type="checkbox"/> 18"	<input type="checkbox"/> 30"	<input type="checkbox"/> 42"	<input type="checkbox"/> 54"
<input type="checkbox"/> 21"	<input type="checkbox"/> 33"	<input type="checkbox"/> 45"	<input type="checkbox"/> 57"

### Optional 3-Sided Guarding Depth (measured from rear of platform)

N/A  24"  30"  36"  42"

### Fork Pockets (required on models without casters)

No  
 Yes (if selected, identify A & B dimensions as identified in figure)  
 (A) Vertical offset between operator platform & top of fork: \_\_\_\_\_  
 (B) Maximum overall width of forks: \_\_\_\_\_

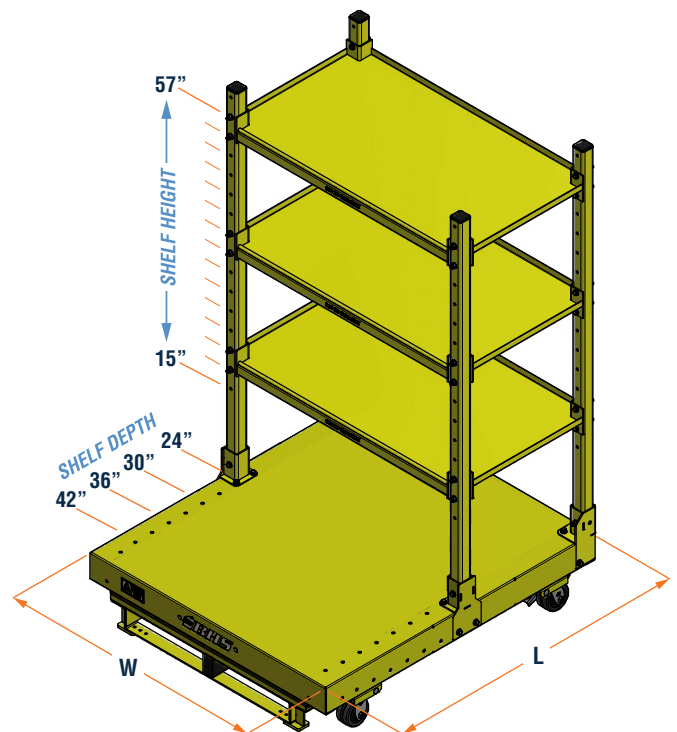
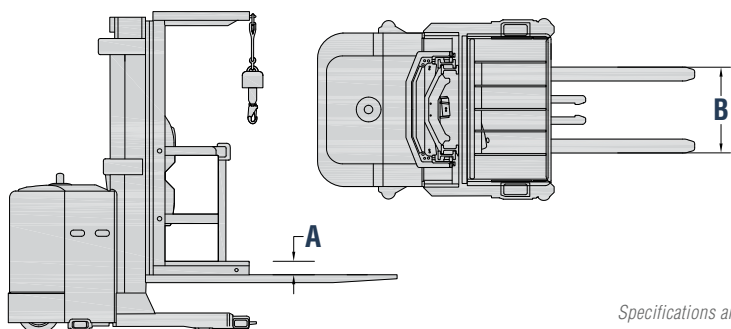

### Additional Options

Handle  
 For model with shelves (OPCM-HDL)  
 For model without shelves (OPCM-PUSH)  
 Handrails for models without shelves (OPCM-HR)  
 Adjustable Fork Guides (OPCM-FP-GUIDE)  
 Anti-Skid Tape (SKIDTAPE)  
 Custom Lasered Logo (OPCM-LOGO)  
 Custom Color: \_\_\_\_\_

### Notes