

Forklift Battery Charger Stands & Cable Management

BHS offers the most comprehensive line of products and accessories for use with forklift battery chargers. Provide safe, convenient access to battery charging equipment by securely mounting chargers on dedicated charger stands built to withstand harsh environments, and by properly routing cables. BHS charger stands and accessories offer practical solutions for improved charger storage and cable management. (Chargers not included.)



BHS provides custom battery handling equipment to meet any challenge.

Contact BHS at 1.800.BHS.9500 to learn more about fully customized solutions for the battery room and beyond.

Charger Stand

Charger Stands come in several models and provide a safe, convenient location for battery chargers.

FEATURES & BENEFITS

- Heavy-duty construction for added reliability
- Fluid corners on the charger shelf increase product longevity
- CR-1 Cable Retractor mounting holes
- SB connector mounting holes
- Charger anchoring slots for securing most makes of chargers
- Charger shelves come slotted, allowing for optional 6" (152 mm) shelf extension between stands
- Custom-built models also available to meet unique specifications

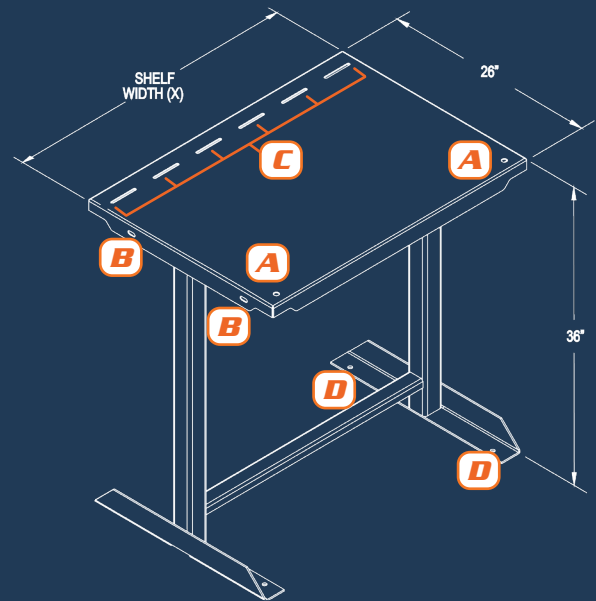

- A. CR-1 Cable Retractor Mounting Holes
- B. Shelf Extension Slots, 6" (152 mm) shelf extension is optional

- C. Charger Anchoring Slots (secures most makes of chargers)
- D. Floor Anchoring Hole



CS-36

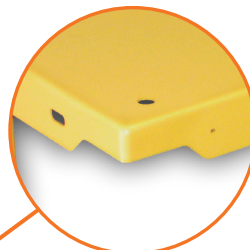

Fluid corners



AVAILABLE MODELS

Model	Shelf Width (X)	Shelf Capacity
CS-24	24" / 610 mm	800 lb / 363 kg
CS-36	36" / 914 mm	800 lb / 363 kg
CS-72	72" / 1829 mm	1,200 lb / 544 kg
CS-24-KDF*	24" / 610 mm	800 lb / 363 kg
CS-36-KDF*	36" / 914 mm	800 lb / 363 kg

* CS-KDF models are bolt-together design and shipped unassembled to reduce freight cost when ordered in bulk. Assembly hardware and tools included.



CS-72

Multi-Tier Charger Stand

Multi-Tier Charger Stands come in several models and provide a safe, convenient location for storing battery chargers.

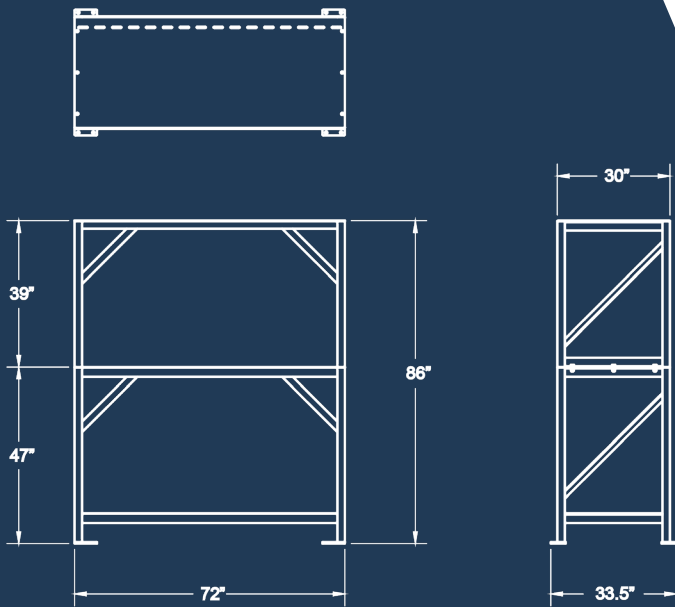

CS-72-3TIER

FEATURES & BENEFITS

- Heavy-duty construction for added reliability
- Charger anchoring slots for securing most makes of chargers
- 800 lb (363 kg) capacity per shelf
- Custom-built models also available to meet unique specifications

AVAILABLE MODELS

Model	Shelf Width	Depth	Height
CS-36-2TIER	36" / 914 mm	30" / 762 mm	47" / 1194 mm
CS-36-3TIER	36" / 914 mm	30" / 762 mm	86" / 2184 mm
CS-36-4TIER	36" / 914 mm	30" / 762 mm	125" / 3175 mm
CS-72-2TIER	72" / 1829 mm	30" / 762 mm	47" / 1194 mm
CS-72-3TIER	72" / 1829 mm	30" / 762 mm	86" / 2184 mm
CS-72-4TIER	72" / 1829 mm	30" / 762 mm	125" / 3175 mm
CS-84-2TIER	84" / 2134 mm	30" / 762 mm	47" / 1194 mm
CS-84-3TIER	84" / 2134 mm	30" / 762 mm	86" / 2184 mm



CS-72-3TIER

Charger Stand Kits for Wall-Mount Chargers

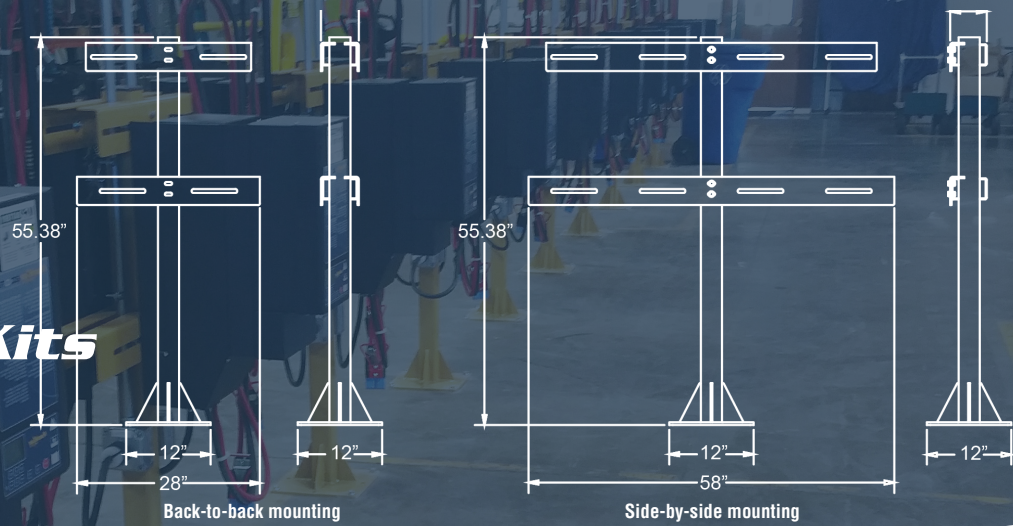

BHS Charger Stand Kits provide dependable, compact storage for wall-mount chargers. These charger stands are ideal for opportunity charge and park & charge applications, but can be configured for use with conventional forklift battery chargers, as well. Stands are adjustable to fit any size charger, and models are available for mounting either one, two, or four chargers.

FEATURES & BENEFITS

- Heavy-duty construction for added reliability
- Compact design with a narrow footprint to fit in small spaces
- Steel stand anchors securely to the floor, allowing users to position chargers anywhere in the facility
- Fully adjustable at any level to fit any charger
- Durable powder-coat finish resists damage from battery electrolyte, scratches, and impacts
- Helps comply with OSHA standards



Charger Stand Kits support wall-mount chargers (left), as well as conventional chargers when used with Charger Wall Brackets (right).

Single Charger Stand Kit

Mount one forklift battery charger to the Single Charger Stand Kit. Two models are available for your choice between convenient charger cable management methods.

PRODUCT SPECIFICATIONS

	CS-VHK-1*	CS-VHK-1-M
Overall Width	28" / 711 mm	
Overall Height	55.38" / 1407 mm	
Overall Depth	12" / 305 mm	
Total Capacity	600 lb / 272 kg	
Cable Management	Cable Retractors	Magnetic Cable Mount

* 70" (1778 mm) overall height including Cable Retractors

CONTENTS

- Single charger stand
- (1) Cable Retractor or (1) Magnetic Cable Mount
- (2) Short crossbars
- (4) Floor anchors



CS-VHK-1-M

Dual Charger Stand Kit

The Dual Charger Stand Kit is designed to mount two wall-mount chargers, either back-to-back or side-by-side. All components to mount chargers in either configuration are included. Two models are available, providing a choice in charger cable management.

CONTENTS

- Dual charger stand
- (2) Cable Retractors with model CS-VHK-2 or (2) Magnetic Cable Mounts with model CS-VHK-2-M
- (2) Long crossbars – for side-by-side mounting of chargers
- (4) Short crossbars – for back-to-back mounting of chargers
- (4) Floor anchors



CS-VHK-2

Shown with chargers in back-to-back configuration with Cable Retractors



CS-VHK-2-M

Shown in side-by-side configuration with Magnetic Cable Mounts

PRODUCT SPECIFICATIONS

Mounting Configuration	CS-VHK-2*		CS-VHK-2-M	
	Back-to-back	Side-by-side	Back-to-back	Side-by-side
Overall Width	28" / 711 mm	58" / 1473 mm	28" / 711 mm	58" / 1473 mm
Overall Height	55.38" / 1407 mm		55.38" / 1407 mm	
Overall Depth	12" / 305 mm		12" / 305 mm	
Total Capacity	1,200 lb / 544 kg	600 lb / 272 kg	1,200 lb / 544 kg	600 lb / 272 kg
Cable Management	Cable Retractors		Magnetic Cable Mounts	

* 70" (1778 mm) overall height including Cable Retractors

Quad Charger Stand Kit

The Quad Charger Stand Kit is designed to mount four wall-mount chargers. Two models are available, providing a choice in charger cable management.

CONTENTS

- Dual charger stand
- (4) Cable Retractors with model CS-VHK-4 or (4) Magnetic Cable Mounts with model CS-VHK-4-M
- (4) Long crossbars – for side-by-side mounting of chargers on the front and back
- (4) Floor anchors

PRODUCT SPECIFICATIONS

Mounting Configuration	CS-VHK-4*	
	CS-VHK-4*	CS-VHK-4-M
Overall Width	58" / 1473 mm	
Overall Height	55.38" / 1407 mm	
Overall Depth	12" / 305 mm	
Total Capacity	1,200 lb / 544 kg	
Cable Management	Cable Retractors	Magnetic Cable Mounts

* 70" (1778 mm) overall height including Cable Retractors



CS-VHK-4-M

CS-VHK-4

Vertical Charger Stand

Vertical Charger Stands are available in three models, providing a safe, convenient location for vertical mount chargers.

FEATURES & BENEFITS

- Heavy-duty construction for added reliability
- Designed and built specifically for vertical mount chargers
- Available mounting for up to three chargers
- Frees up valuable floor space

AVAILABLE OPTIONS

Arm (CS-VMP-ARM)

Arm allows charger cables to be routed over a battery stored on a BSXX-1 battery stand, and provides a convenient location for SB mount and connection

Note: Not available on CS-VMP-1



CS-VMP-2 shown with optional Arm and Battery Stand

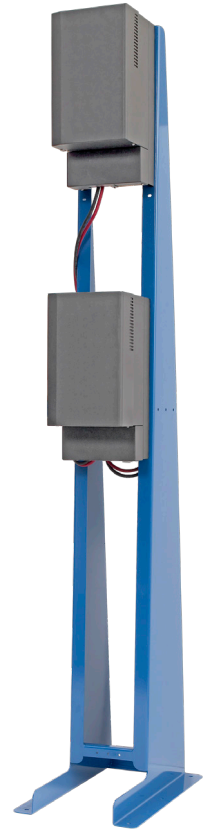

CS-VMP-2

AVAILABLE MODELS

Model	Overall Depth w/o Arm (A)	Overall Width at Top (B)	Overall Width at Base (C)	Overall Height (D)	Shipping Weight
CS-VMP-1	28" / 711 mm	11" / 280 mm	16.75" / 425 mm	47.13" / 1197 mm	55 lb / 25 kg
CS-VMP-2	28" / 711 mm	11" / 280 mm	16.75" / 425 mm	80" / 2032 mm	87 lb / 40 kg
CS-VMP-3	28" / 711 mm	11" / 280 mm	16.75" / 425 mm	112" / 2845 mm	109 lb / 50 kg

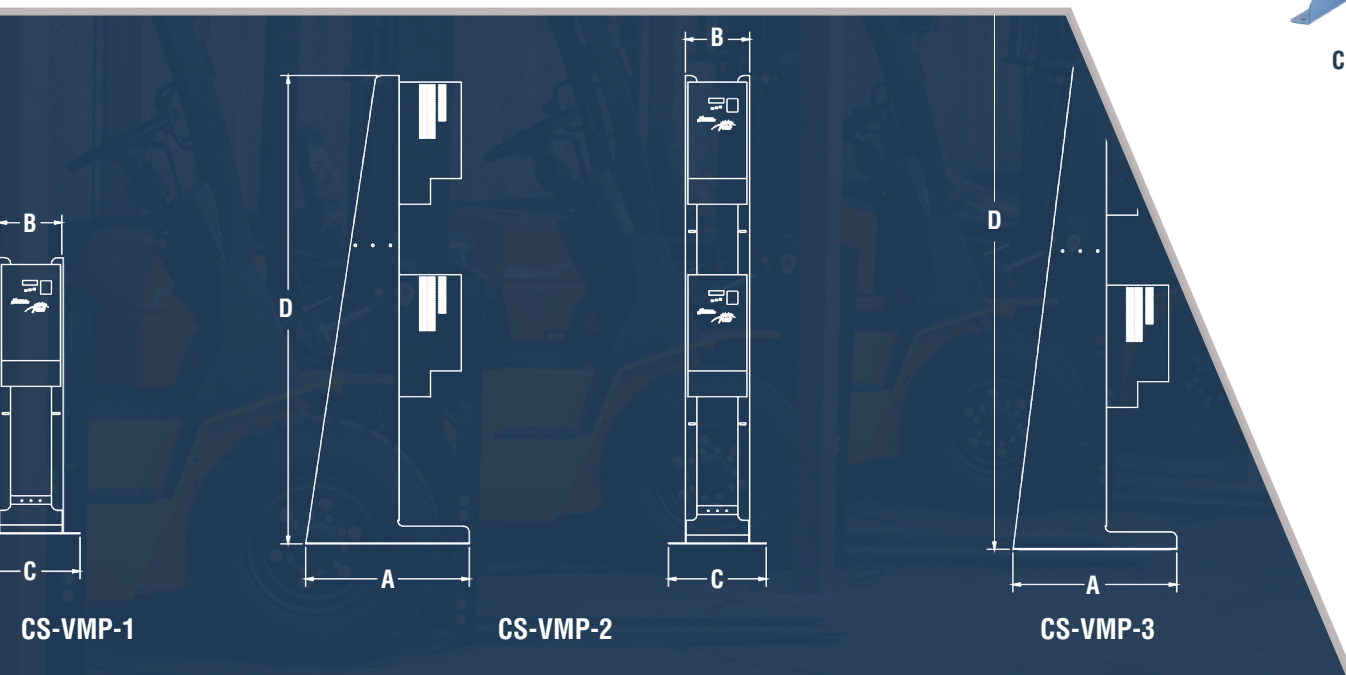

Vertical Charger Mount

The Vertical Charger Mount (VCM) is mounted to a charger stand or racking to accommodate chargers that are typically mounted to walls.

FEATURES & BENEFITS

- Heavy-duty construction for added reliability
- Charger mounting holes for securing most makes of chargers
- Frees up valuable floor space

AVAILABLE MODELS

Model	Overall Depth	Overall Width	Overall Height	Shipping Weight
VCM-1	12" / 305 mm	0.75" / 19 mm	37.5" / 953	20 lb / 9 kg
VCM-2	12.125" / 308 mm	16.375" / 416 mm	85" / 2159 mm	58 lb / 26 kg



VCM-1

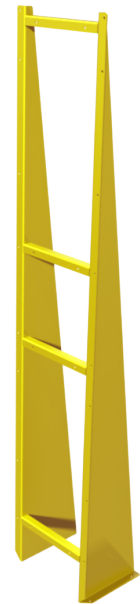

VCM-2

Charger Wall Bracket

The Charger Wall Bracket (CWB) is a set of two sturdy, easy-to-install brackets. The CWB is an economical solution for mounting battery chargers.

FEATURES & BENEFITS

- Helps prevent charger damage
- Frees up valuable floor space
- Supports up to 400 lb (181 kg) when mounted on a wall with sufficient bearing strength
- 24.13" (613 mm) deep x 24.13" (613 mm) tall
- Made of galvanized steel to prevent corrosion. Also available with yellow (CWB-Y), black (CWB-BLK), or blue (CWB-BLU) powder-coat.

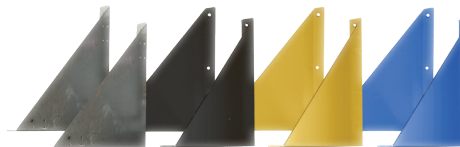

CWB



Mounted CWB with charger

High Frequency Charger Wall Bracket

The CWB-V1-KD charger wall bracket offers a sturdy and economical solution for wall-mounting high-frequency forklift battery chargers. The "knock down flat" design allows for efficient shipping. Assembly hardware is included in addition to a Cable Retractor Mounting Bracket (Cable Retractor sold separately).

FEATURES & BENEFITS

- Helps prevent charger damage and frees up valuable floor space
- 22" (559 mm) deep x 24.0625" (611 mm) tall
- 16.5" (419 mm) storage width
- Made of galvanized steel. Also available with black powder-coat (CWB-V1-KD-BLK).
- 400 lb (180 kg) capacity when mounted on a wall of sufficient strength

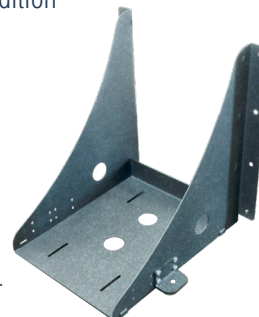

CWB-V1-KD



Can also mount to CS-VHK series stands.

Cable Retractors

Cable Retractors utilize a heavy duty spring with safety chain for added protection and include a cable clamp to suspend charger cables. Cable Retractors mount to the shelves of BHS Battery Stands or Charger Stands using pre-drilled mounting holes or to BHS Charger Wall Brackets using a Cable Retractor Mounting Bracket (sold separately).

FEATURES & BENEFITS

- Heavy-duty spring with safety chain
- Threaded mounting stud with nut
- CR-1 & CR-1-50 support up to 10' (3 m) of 2/0 charger leads
- CR-ESC supports up to 25' (7.6 m) of 2/0 charger leads



Cable Retractor (CR-ESC) Mounted on 24" Single Level Charger Shelf (CS-24)

CR-1	CR-1-50	CR-ESC
7 lb capacity 34" (864 mm) long x 1" (25 mm) diameter pole	7 lb capacity 50" (1270 mm) long x 1" (25 mm) diameter pole	17 lb capacity 34" (863 mm) long x 1" (25 mm) diameter pole

Heavy Duty Cable Retractor

The Heavy Duty Cable Retractor (80912001) holds larger cables and is adjustable and lightweight. The Cable Retractor mounts to BHS Battery Stands, Charger Stands, or Charger Wall Brackets by way of (2) 0.38" (10 mm) diameter mounting holes.

FEATURES & BENEFITS

- Bolts to charger bracket or charger shelf
- Adjustable tension spring
- Reaches up to 10' (3 m)
- Supports up to 12' (3.66 m) of 4/0 charger leads
- HDPE acid resistant clamp

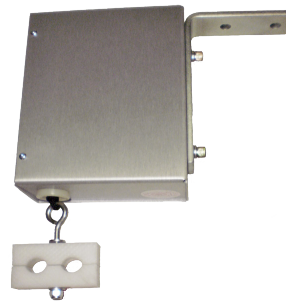

80912001

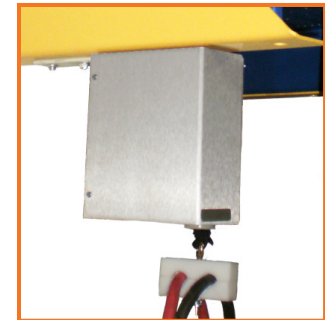

80912001 mounted on CWB

Cable Retractor Mounting Bracket

The Cable Retractor Mounting Bracket (CR-MT) allows the BHS Cable Retractor (CR-1) to be mounted on a Charger Wall Bracket (CWB).

FEATURES & BENEFITS

- Mounts to BHS Charger Wall Brackets by way of (4) 0.31" (8 mm) diameter mounting holes
- Mounting hardware included
- Made of galvanized steel to prevent corrosion. Also available with yellow (CR-MT-Y), black (CR-MT-BLK), or blue (CR-MT-BLU) powder-coat.



CR-MT

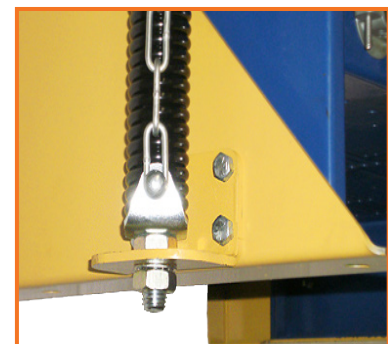

CR-MT-Y shown mounted on CWB with CR-1

Magnetic Cable Mount

The Magnetic Cable Mount (CR-M) is a convenient tool that safely secures battery and charger cables, preventing cable damage and clutter. The CR-M mounts to any flat, ferrous metallic surface such as a Charger Stand, Charger Wall Bracket, or charger case.

FEATURES & BENEFITS

- 3.25" (83 mm) diameter magnet mounts to any flat, ferrous metallic surface
- Allows precise positioning of cable and connector
- Intended for two standard battery cables
- Supports up to 10' (3 m) of 2/0 charger leads
- Magnet housing is constructed of durable chrome plated steel
- HDPE acid resistant clamp



CR-M



CR-M attached to CWB

SKID-LOADS OF SAVINGS

Maximize total cost savings by ordering in bulk. Select Charger Stands and Cable Management products can be ordered by the skid-load for special pricing. Quantity and availability varies by product. Contact a BHS Representative for more details.



NORTH AMERICA: P.O. Box 28990, St. Louis, MO 63132 USA • 1.800.BHS.9500 • Fax: 314.423.6444 • sales@bhs1.com • BHS1.com
INTERNATIONAL: P.O. Box 12429, St. Louis, MO 63132 USA • +1 314 423 2075 • Fax: +1 314 423 3034 • sales@bhs1global.com
Specifications are subject to change without notice. ©2010-2024 BHS, Inc. St. Louis, MO. Data Sheet: PL-2100 03/24

