

## Chapter 13 – Weather

### The Difference Between Weather and Climate:

- **Climate** mean the **average** atmospheric conditions of an area over a considerable time whereas climate mean the average atmospheric conditions of an area over a minimum period of 35 years is desirable.
- This involves the systematic observation, recording and processing of the various elements of climate such as rainfall, temperature, humidity, air pressure, winds, clouds and sunshine before any standardization of the climatic means or averages can be arrived at.
- The **degree of variability** in the climate or weather of a country also differs, the climate of temperate latitudes is far more variable than that of the tropics.

### The Importance of Climate and Weather:

- Forces of nature have regulated to a very great extent the sort of food we eat, what we wear, how we live and work. Our mental alertness, our physical characteristics and even our racial differences when closely examined have at least some relationship with climate.
- The direction of winds once controlled the pattern of trading routes. The safety of modern air communications is closely tied to accurate meteorological reports from the ground stations.
- Conditions of temperature, precipitation and humidity may promote or discourage the growth of fungus and diseases which may be injurious to both men and crops.
- Death rates are normally high in tropical countries and low in deserts, because germs are not transmitted readily in regions of high temperature and low humidity. Cool, fresh mountain air is always good for health.
- Though men are still unable to tame the forces of nature such as floods, droughts, typhoons or hurricanes, a sound knowledge of the trends or the weather system can often help to avoid or reduce the seriousness of the calamities.

- Professional meteorologists are able to **forecast** the weather fairly accurately from local observation.
- To-day farmers are becoming more and more dependant upon meteorological services. A knowledge of the likely weather of a place will be useful for a farmer to plan his work for the season or the year.
- Frequent agricultural bulletins issued by the Meteorological Office will assist farmers to take due precautions against frosts, hail, heavy snowfall or a period of possible drought.
- Modern air transport, military operations, geographical expeditions, even important games and outings, often take due consideration of meteorological reports. A fair knowledge of the weather is not only useful but often essential.

### The Elements of weather and climate:

To collect various climatic data and to prepare maps and charts of them, the following elements of climate are normally observed and measured by weather instruments:

#### 1. Rainfall:

- Rainfall including other forms of **precipitation** (snow, sleet and hail) is always measured by a metal instrument called a **Rain gauge**.

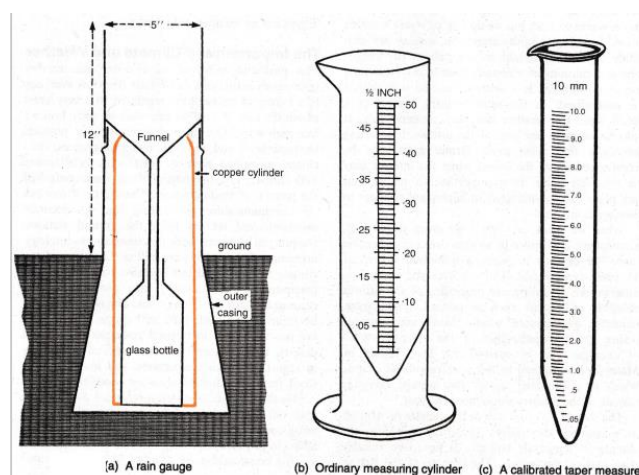

- It consists of a copper cylinder with a metal funnel either 5 inches or 8 inches in diameter, which leads into a smaller copper container or a glass bottle.

- The hole in the funnel that leads down to the container is very small so that evaporation of the collected rain is minimised.
- The gauge should be at least one foot above the ground and firmly fastened, to avoid splashing. The instrument should be sited well away from tall buildings, high trees and other objects which would shelter it.
- The measurement of the rainfall is done by removing the funnel, emptying the rain in the container into a **graduate cylinder** with a  $1\frac{1}{2}$  inch diameter.
- The reading should be done at eye-level and to an accuracy of 0.01 inch. For greater accuracy, a special kind of **taper measure**, which tapers bottom may be used.

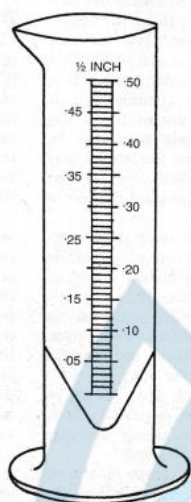

(b) Ordinary measuring cylinder

- It gives an accuracy up to 0.005 inch. An inch of rainfall means the amount of water that would cover the ground to a depth of 1 inch, provided none evaporated, drained off or percolated away.
- For meteorological recording, a rain-day is reckoned as a period of 24 hours with at least 0.01 inch or more rain being recorded. If the amount exceeds 0.04 inch, it is considered a wet day.
- The rain gauge must be examined every day. In temperate regions, snowfall is carefully melted by warming the funnel and then measured. For all practical purposes 10 to 12 inches of snow may be considered as equivalent to 1 inch of rain.
- The daily records of rainfall will be added at the end of the month to find the total rainfall

for that month. The total for each month is again added at the end of the year to find the annual rainfall.

- The **mean annual rainfall** is obtained from the averages of annual rainfall taken over a long period of say 35 years.
- For plotting in rainfall maps, places having the same mean annual rainfall are joined by a line called an **isohyet**, as shown in many atlases.
- Rainfall can also be graphically depicted as shaded rainfall columns, one for each month of the year, illustrates the monthly rainfall regime over a year for 35 years.

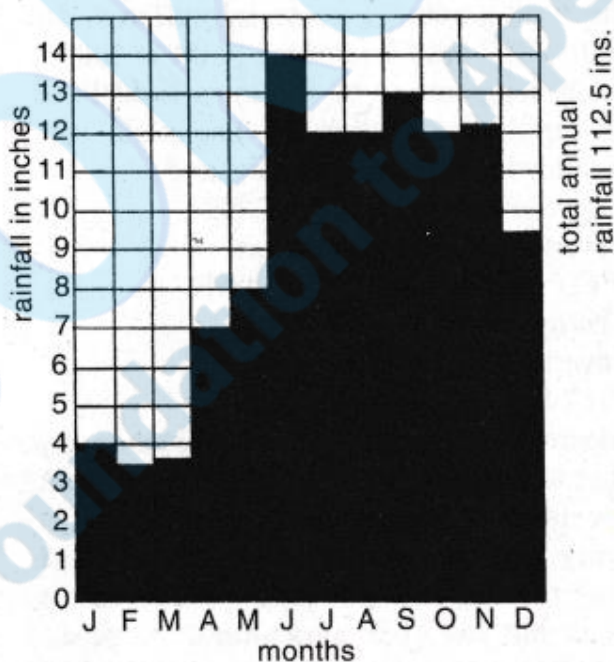

A rainfall histogram showing the monthly rainfall of Kota Kinabalu, E. Malaysia

- In dispersal diagrams, one dot for each year for as many years as possible, shows at a glance the range of dry and wet years for 35 years.

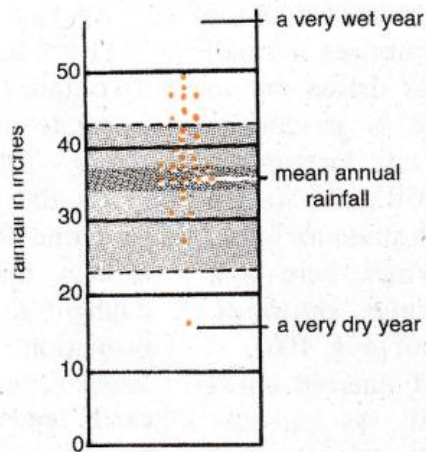

A rainfall dispersal diagram for Gibraltar for 35 years

## 2. Pressure:

- Air is made up of a number of mixed gases and has weight. It therefore exerts a pressure on the earth's surface which varies from place to place and from time to time.

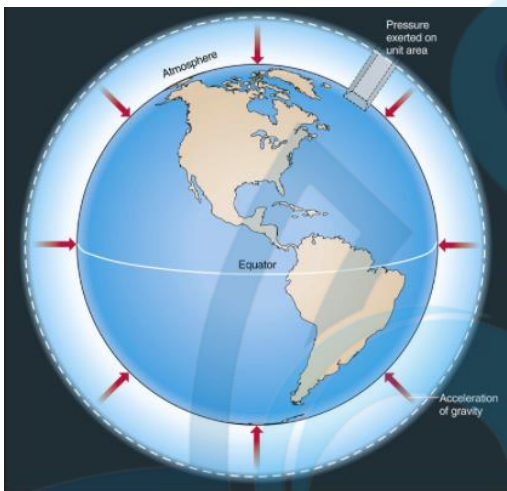

- The instrument for measuring pressure is a **Barometer**, invented by the scientist Galileo and his assistant Torricelli in 1643.

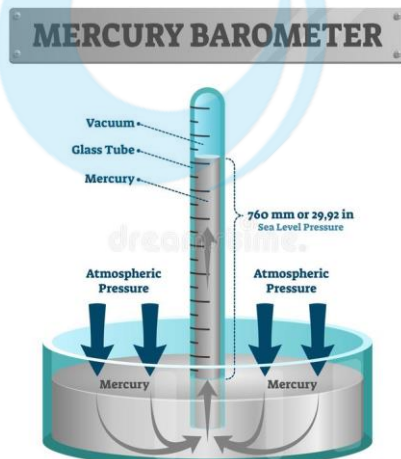

- The ordinary mercury barometer consists of a long glass tube, sealed at the upper and open at the lower end. The lower end is inverted in a bowl of mercury whose surface is exposed to the air.
- Variations in the atmospheric pressure on the mercury surface are balanced by the column of mercury in the glass tube.
- This gives the pressure of the air and can be read off quickly from the scale on the glass tube. Any liquid could be used for this purpose, but mercury has been chosen because it is the heaviest liquid known.
- If ordinary water were used, the corresponding column for normal atmospheric pressure would be 34 feet! At sea level, the mercury column is 29.9 inches, or 760mm.
- If the pressure increases, the air pressing on the surface will force up the mercury column to about 31 inches (high pressure). When the pressure decreases, as less air presses on the surface, the mercury column will drop about 28 inches (low pressure).
- As pressure is a **force**, it is more appropriate to measure it in terms of a unit of force. A new unit known as the **millibar(mb)** was adopted by meteorological stations in 1914.
- A normal atmospheric pressure equivalent to 14.7 lb. per square inch in weight or a reading of 29.9 inches of mercury in the column is 1013 millibars.
- on maps places of equal pressure are joined by lines called **isobars**. In temperate latitudes, pressure changes are very rapid in the formation of cyclones and anticyclones. In normal circumstances, they vary from 960 mb. to 1,040 mb.
- Pressure readings vary with a number of factors. A sea-level reading of 30 inches will be halved on mountainous regions of 3.5 miles above sea level.
- This is because as one **ascends** there is less air above and so the weight, or **pressure is less**.
- The barometer is also sensitive to gravitational forces at different **latitudes**. The mercury itself also expands with an increase in **temperature**.

- Since a mercury barometer that dips in liquid mercury is inconvenient for outdoor measurement, a more portable but less accurate type known as the **aneroid barometer** is used.
- This comprises a small metal container, with most of the air driven out to form almost a vacuum.
- As there is practically no pressure at all inside the box, any increase in pressure on the outside of the box will cause the lid to move inwards thus registering high pressure by an indicator on the revolving dial.
- When there is a decrease in pressure, the lid springs outwards, registering low pressure by the indicator.

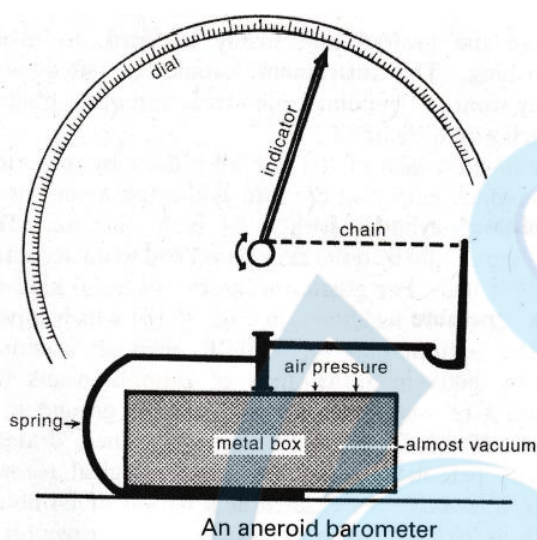

- In aeroplanes, a modified type of aneroid barometer called an **altimeter** is used.
- As pressure decreases with altitude at an approximate rate of 1 inch drop in the mercury reading for every 900 feet ascent, the altimeter gives the reading in feet for height attained instead of millibars or inches.
- With this, the pilot will be able to tell the altitude of the plane above sea level. For a continuous record of pressure changes, as is sometimes required, the self-recording **barogram** is used.

### 3. Temperature:

- Temperature is a very important element of climate and weather. The instrument for measuring temperature is the **Thermometer** which is a narrow glass tube

filled with mercury or alcohol. It works on the principle that mercury expands when heated and contracts when cooled.

- on thermometers, temperatures are marked in one of two ways. In °F (Fahrenheit) the freezing-point is 32°F and the boiling-point is 212°F.
- For most scientific purposes the Centigrade °C scale is preferred. Its freezing-point is 0°C and its boiling-point is 100°C.
- As the degree of 'hotness' varies tremendously from one place to another, the **siting** of the instrument is very important.
- A temperature taken in open daylight is very high, because it measures the direct insolation of the sun. It is better described as 'temperature in the sun'.
- For agricultural purposes, **earth temperature** is taken at various depths in the ground. The thermometer is enclosed in a special glass tube and the bulb is embedded in paraffin wax, so that they are less sensitive to abrupt temperature changes.
- To assess the possible damages done by ground frosts to crops in temperate latitudes, **grass temperatures** are also taken.
- But the temperatures that we are so accustomed to in climatic graphs are shade temperatures, that is the temperatures of the **air**.
- Precautions therefore must be taken to exclude the intensity of the sun's radiant heat. This is done by placing the thermometers in a standard' meteorological shelter known as the **Stevenson Screen**.

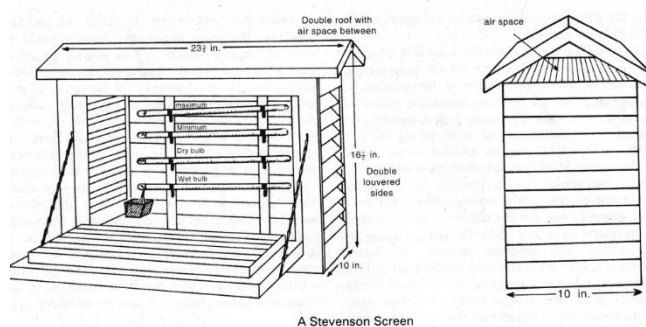

- It consists of a white wooden box raised 4 feet above the ground on stilts. The roof is double-layered with an intervening air space to exclude much of the direct rays of

the sun. The sides of the box are louvred like 'venetian blinds' to allow free circulation of the air.

- One side of the screen is hinged to serve as a door which can be opened and closed to give access to the instruments kept inside. The floor of the screen is also louvred.
- The Stevenson Screen normally carries maximum and minimum thermometers, dry and wet bulb thermometers. Larger ones may also contain a self-recording **Thermogram and Hygogram**.
- Maximum and minimum temperatures are measured by the **Maximum and minimum thermometer**.
- They are either in the form of separate thermometers or joined in a U-shaped glass tube as in the Six's thermometer.
- The maximum thermometer records the **highest temperature** reached during the day. The mercury in the closed glass tube expands when the temperature rises. It pushes a metal indicator up the tube and this stays at the maximum level when the temperature drops
- The end of the indicator nearest the mercury, gives the reading of the maximum temperature, which is 87°F. in this case. To reset the mercury for the next day's reading, swing it hard or draw the indicator back by a magnet.
- The minimum thermometer records the **lowest temperature** reached during the day, it Probably occurs in the middle of the night or early in the morning.
- The glass tube is filled with **alcohol** which allows the indicator to slide freely along the tube. When the temperature drops, the alcohol contracts and drags the indicator towards the bulb by the surface tension of the indicator.
- When the temperature rises, the alcohol flows past the indicator leaving it where it was. The end of the indicator farthest from the bulb gives the reading of the minimum temperature, which is 73°F. The thermometer is then reset by a magnet for the next 24 hours' reading.
- In recording temperature, the maximum temperature is entered in the column for the

**previous day** and the minimum temperature in the column for **current day** because of their respective period of probable occurrence.

- The **mean daily temperature** the average of maximum and minimum e.g.,  $(87^{\circ}\text{F}+73^{\circ}\text{F})/2 = 80^{\circ}\text{F}$ . But an accurate mean should be the average of 24 reading taken at hourly intervals during the whole day. In practice this is almost impossible except with a self-recording instrument.
- The difference between the maximum and minimum temperatures of a day gives the **diurnal range** of temperature.
- The difference between the hottest month (i.e., July in the northern hemisphere) and the coldest month (i.e., January in the northern hemisphere) gives the annual range of temperature.
- In diagrammatic representations, monthly mean temperatures are shown in simple temperature graphs or in temperature distribution maps as **isotherms**.

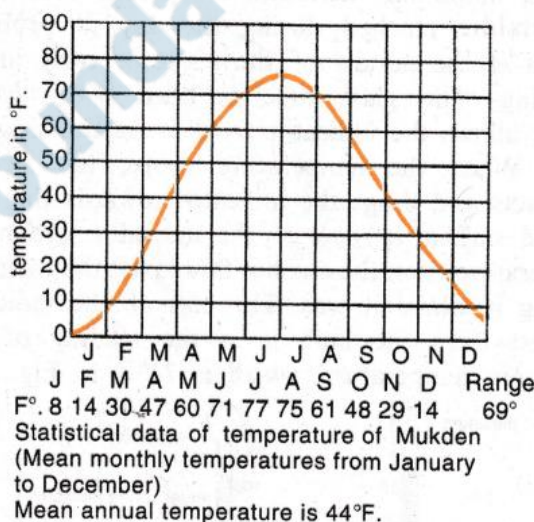

**A temperature graph of Mukden, Manchuria (42°N., 123°E.)**

- For these maps temperatures are **reduced to sea level**- that is shown as if the recording station were at sea level.
- Temperatures decrease at the rate of 1°F. drop in temperature for 300 feet ascent in altitude, so for highland stations a higher temperature is shown than was actually recorded.

#### 4. Humidity:

- Humidity is a measure of the **dampness of** the atmosphere which varies greatly from place to place at different times of day.
- The actual amount of water vapour present in the air, which is expressed in grams per cubic metre, is called the **absolute humidity**. But more important from the point of view of weather studies is the **relative humidity**.
- This is the ratio between the actual amount of water vapour and the total amount the air can hold at a given temperature, expressed as a percentage.
- Warm air can hold more water vapour than cold air, so if it contains only half the amount it could carry, the relative humidity is 50 per cent.
- In the equatorial regions, over 80 per cent is common in the morning, which means the air contains four-fifths as much water vapour as it can carry.
- When the relative humidity reaches 100 per cent, the air is completely **saturated**. The air temperature is said to be at **dew-point**.
- Further cooling will condense the water vapour into clouds or rain. It is thus clear that when relative humidity is high the air is moist, as in the equatorial regions; when it is low, the air is dry as in the deserts.
- The instrument for measuring relative humidity is the **Hygrometer**, which comprises **wet and dry bulb thermometer** placed side by side in the Stevenson Screen.

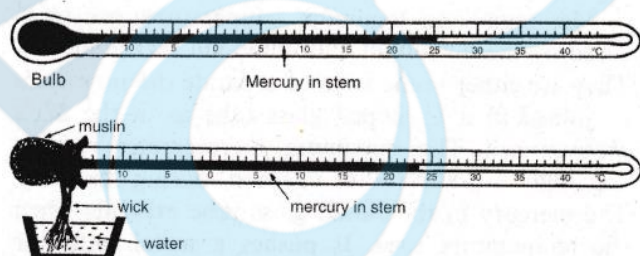

The hygrometer consisting of wet and dry bulb thermometers

- The dry-bulb is, in fact, the ordinary thermometer that measures the shade temperature mentioned earlier. The wet-bulb is kept wet by a wick that dips into a reservoir of distilled water.

- When there is not saturated evaporation, which produces a **cooling effect**, takes place from the moist wick.
- The wet bulb therefore always shows a lower reading than the dry bulb. With reference to prepared tables for calculating relative humidity, under the difference column of the dry and wet bulb reading, the relative humidity can be obtained as a percentage.
- Normally a large difference indicates a low R.H. and a small difference a high R.H. If both have the same reading, R.H. is 100 per cent; the air is saturated.

#### 5. Winds:

- Wind is **air in motion** and has both direction and speed. Unlike other elements in climate such as rain, snow or sleet, winds are made up of a series of gusts and eddies that can only be felt but not seen.
- The instrument widely used for measuring **wind direction** is a **wind vane** or weather cock. As wind direction is always blocked by trees and tall buildings, weather cocks and wind vanes need to be erected in an exposed position, to get a true direction.
- It is made up of two parts (a) and (b). One part is an arrow or vane on the top, which is free to move with the prevailing wind.

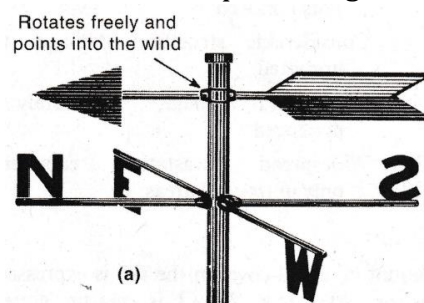

- The other part with the four compass points is stationary and shows in which direction the wind is moving.

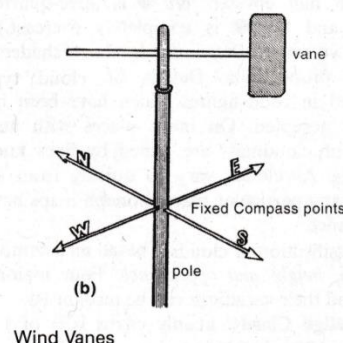

- Winds are always named **from the direction they blow**, an east wind is one that blows from east to west and a south-west wind is one that blows from the south-west.
- Most of the weather cocks that we see on church spires and country buildings seldom give a correct indication of wind directions.
- They are either too low or are blocked by taller structures nearby. The direction of smoke-drift or flag movements in fairly open spaces provides the most reliable indication of wind direction.
- Sometimes a piece of woven cloth with a tail is fixed to the top of a high pole and drifts freely in mid-air. This is another way of indicating wind direction.
- The speed of wind is usually measured by an **anemometer**. It consists of three or four semi-circular cups attached to the ends of horizontal spokes mounted on a high vertical spindle.

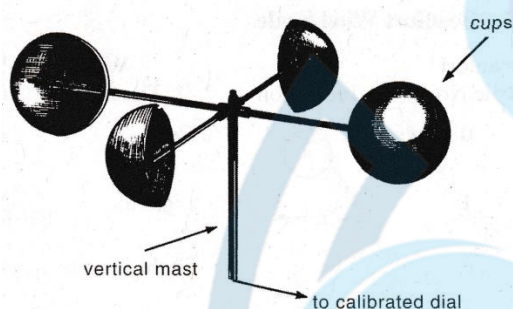

Simplified sketch to illustrate the main features of a wind anemometer

- As the concave sides of the cups offer greater resistance to the winds, the horizontal spokes will rotate, moving a central rod which transmits the velocity (speed) of the wind in miles per hour to an electrically operated dial.
- But the speed recorded is not absolutely accurate because after the winds have abated, the rotation continues due to its own momentum. With some modifications, the anemometer can also record wind directions.
- Since an anemometer is not easily available, a little practice of local wind observations will help us to assess the speed of winds.

- The best guide is obtainable from the **Beaufort wind scale** which was devised by Admiral Beaufort in 1805 for estimating wind speed.

#### 6. Sunshine:

- The amount of sunshine a place receives, depends on the seasons, a factor determined by latitude and by the position of the earth in its revolution around the sun.
- In the meteorological station, sunshine duration is recorded by a **sun-dial**, 4 Inches in diameter, through which the sun's rays are focussed upon a sensitized card, graduated in hours.
- A line is made on the card when it is sufficiently heated, but not when the rays are faint. on maps places with equal sunshine duration are joined by **isohels**.

#### 7. Clouds:

- when air rises, it is cooled by expansion. After dew-point has been reached cooling leads to **condensation of water vapour** in the atmosphere.
- Tiny droplets of water vapour which are too small to fall as rain or snow (less than 0.001 cm., approximately 0.0005 inches in radius) will be suspended in the air and float as **clouds**.
- For meteorological purposes, the amount of **clouds-cover** in the sky is expressed in **eights or oktas** (e.g.,  $2/8$  ○ is quarter covered,  $4/8$  ◐ is half covered,  $6/8$  ◑ is three-quarters obscured and  $8/8$  ● is completely overcast).
- Details of **cloud type** are indicated in code figures which have been internationally accepted. On maps places with an equal degree of cloudiness are joined by lines known as **isoneps**.
- The **classification of clouds** is based on a combination of form, height and appearance. Four major cloud types and their variations can be recognised:

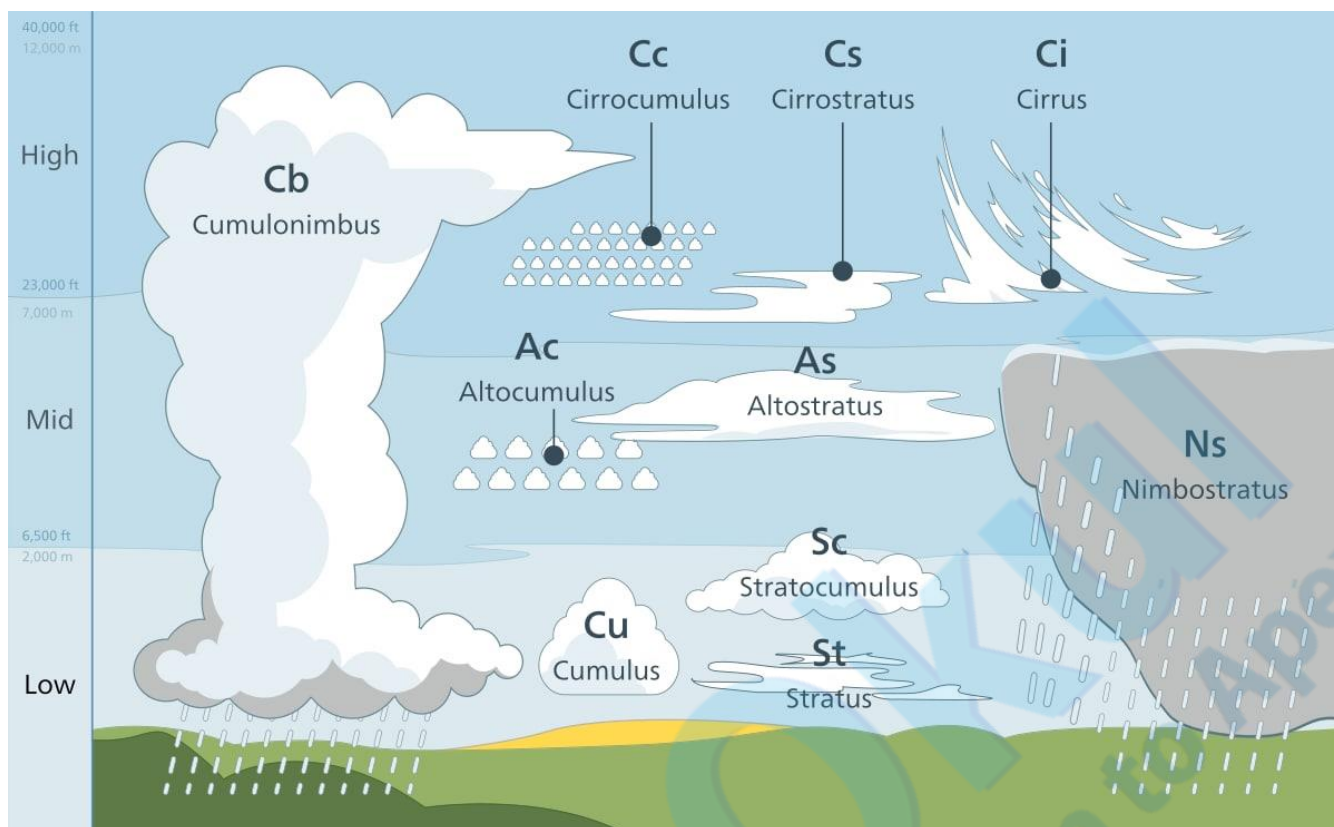

**1. High clouds:** mainly cirrus (Ci) of feathery form at 20-40,000 feet above ground.

**a) Cirrus (Ci)** This looks fibrous and appears like wisps in the blue sky; it is often called 'mares' tails'. It indicates fair weather, and often gives a brilliant sunset.



**b) Cirrocumulus (Cc)** This appears as white globular masses, forming ripples in a 'mackerel sky'.

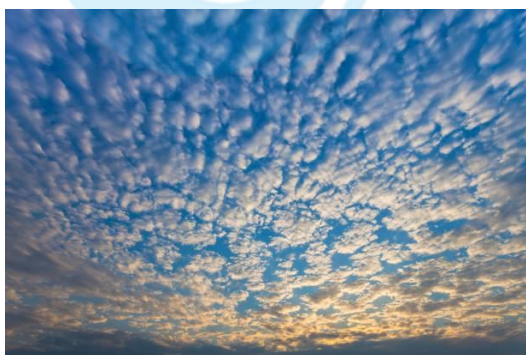

**c) Cirrostratus (Cs):** This resembles a thin white sheet or veil, the sky looks milky and the sun or moon shines through it with a characteristic 'halo'.



**2. Medium clouds:** mainly alto (Alt) or middle-height clouds at 7-20,000 feet.

**a) Altocumulus (Alt-Cu):** These are woolly, bumpy clouds arranged in layers and appearing like waves in the blue sky. They normally indicate fine weather.





**b) Altostratus (Alt-St):** These are denser, greyish clouds with a 'watery' look. They have a fibrous or striated structure through which the sun's rays shine faintly.

**3. Low clouds:** mainly stratus or sheet clouds below 7,000 feet.

**a) Stratocumulus (St-Cu):** This is a rough, bumpy cloud with the waves more pronounced than in altocumulus. There is great contrast between the bright and shaded parts.



**b) Stratus (St):** This is a very low cloud, uniformly grey and thick, which appears like a low ceiling or highland fog. It brings dull weather with light drizzle. It reduces the visibility of aircraft and is thus a danger.



**c) Nimbostratus (Ni-St):** This is a dark, dull cloud, clearly layered, and is also known as a 'rain cloud'. It brings continuous rain, snow or sleet.



**4. Clouds with great vertical extent:** mainly cumulus or heap clouds with no definite height (2-30,000 feet).

**a) Cumulus (Cu):** This is a vertical cloud with a rounded top and horizontal base, typical of humid tropical regions, associated with up-rising convectional currents. Its great white globular masses may look grey against the sun but it is a 'fair weather cloud'.



**b) Cumulonimbus (Cu-Ni):** This is an overgrown cumulus cloud, extending for a tremendous vertical height from a base of 2,000 feet to over 30,000 feet. Its black and white globular masses take a fantastic range of shapes. Its cauliflower top often spreads out like an anvil. This is frequently seen in tropical afternoons. It is also referred to as a 'thunder-cloud' and brings convectional rain, accompanied by lightning and thunder.



**Other Elements pertaining to visibility:** other elements affecting visibility include haze, mist and fog.

**c) Haze:** This is caused by smoke and dust particles in industrial areas or may be due to unequal refraction of light in air of different densities in the lower atmosphere. The term is usually used in connection with the **reduction of visibility** in regions of **low humidity**, less than 75 per cent. when visibility is less than 1 1/4 miles, haze is present.



**b) Mist:** The condensation of water vapour in the air causes small droplets of water to float about forming clouds at ground level called **Mist**. It reduces visibility to about 1,000 metres or 1,100 yards. Unlike haze, mist occurs in **wet air**, when the relative humidity is over 75 per cent.



**c) Fog:** ordinary fog is due to water condensing on dust and other particles like smoke from houses and factories. It only occurs in the **lower strata** of the atmosphere as a sort of dense 'ground cloud'. The visibility in fog is even less than 1,000 metres.



In industrial areas, like those of the Black Country and northern England, very thick **smoky fog** is formed, called **Smog**. The visibility may be reduced to 220 yards or even less.



- Fogs that occur on hills are called **hill fogs**. They are most common in the morning, even in the tropics, and disperse when the sun rises.
- In temperate lands, when days are hot and nights are clear and still, fogs may also result from cooling of the land surface by radiation.
- The lower layers of the air are chilled and water vapour in the atmosphere condenses to form **radiation fog or land fog**.

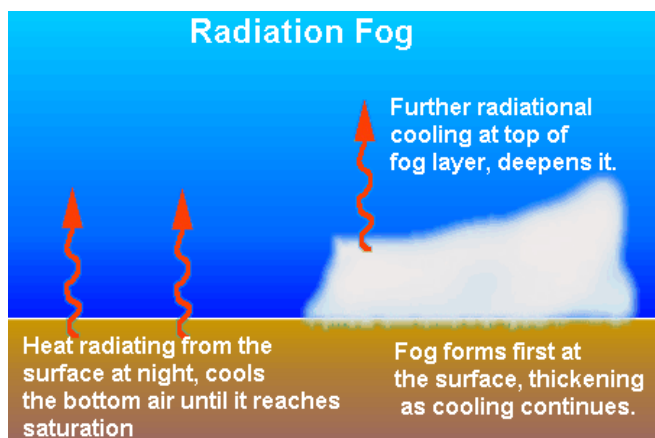

- When the cooling surface is over the sea or when a damp air stream is brought into contact with a cold current **sea fog** is formed.
- It varies in depth and thickness. Some sea fogs are so shallow and light that the masts of ships can be seen protruding above them.

Generally speaking, fogs are more common overseas than lands, and are most prevalent over coastal areas. The dry interiors experience haze or mist. Dense fogs are more likely to occur in the high and middle latitudes rather than the tropics.

\*\*\*\*\*