

Compact Telehandlers

Panoramic 27.6



**PERFORMANCE AND FEATURES****P27.6AUPLUS****Performance**

Unladen weight (kg)	4850
Maximum load capacity (kg)	2500
Lift height (m)	5.9
Maximum reach (m)	3.3
Lift height at max. load capacity (m)	4.6
Reach at max. load capacity (m)	1.2
Load capacity at max. lift height (m)	1800
Load capacity at max. reach (kg)	1000
Boom side-shift (mm)	-
Frame levelling (%)	-
Boom section	2

Powertrain

Engine	Kohler 2504 TCR
Range/Cylinders	2500/4
Engine power (kW/HP)	55,4/75,1
Anti-pollution technology	Tier 4 - DOC
Reversible Fan	-
Maximum speed (km/h)	40
Fuel tank capacity (l)	70
AdBlue tank capacity (l)	
Hydrostatic transmission	YES - 1V
EPD	NO
Joystick autoaccelerante	NO
Axles	Axial
Reducers	Epicyclic
Brakes	Dry discs

Hydraulic

Hydraulic pump	Gear
Delivery / pressure (L / MIN - BAR)	95-210
Hydraulic oil tank capacity (l)	70
Auxiliary hydraulic service on boom	●
Rear service line	○

Cab

Cab finishing	ECO
ASCS	Full
FOPS II Cab	●
ROPS Cab	●
Controls	Electromechanical joystick control
Tilting cab	-
Reverse shuttle	Finger touch

Configuration

Hydropneumatic Suspension CS Merlo	-
Hydropneumatic Suspension BSS Merlo	○
Hydropneumatic Suspension EAS Merlo	-
Work lights on cab	○
Sun-shade in the cab	○
Tac-lock	●
Pre-arrangement for aerial work platform	○
Two floating forks	●
Pedal Inching-Control	●
Permanent four-wheel drive	●
All wheel steering	●
Three steering way	●
Standard tyres	
OPT tyres	
Hydraulically controlled stabilizers	-
Turret rotation	-
Tractor type approval	-
Pneumatic brakes (ton)	-
Hydraulic brakes (ton)	-
PTO	
3-point rear linkage	



- not available
- standard
- optional

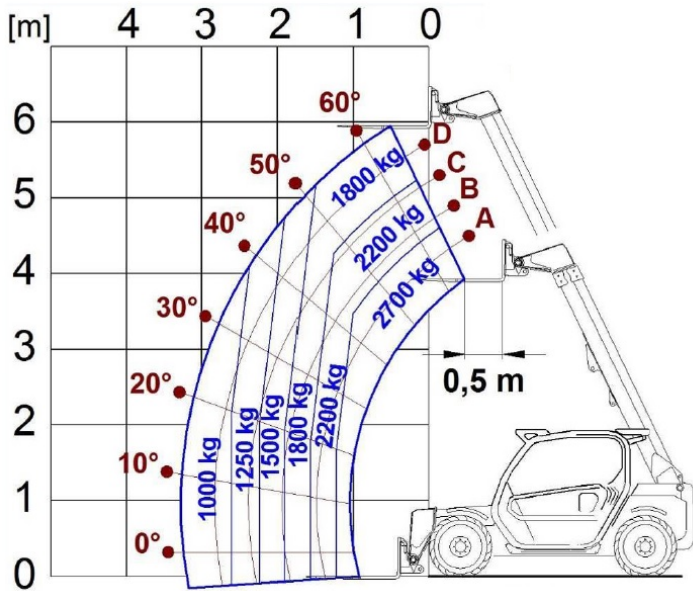

Dimensions



	P27.6AUPLUS		
A - Length	3910		
C - Wheelbase	2450		
F - Ground clearance	270		
H - Width	1860		
M - Cabin width	1010		
P - Height	1960		
R - Turning radius at wheels	3370		
S - Turning radius at forks	4200		

Your Merlo dealer

MERLO S.P.A.

Via Nazionale, 9

12010 S. Defendente di Cervasca, (Cuneo) Italia

Tel. +39 0171 614111

Fax +39 0171 684101

info@merlo.com

www.merlo.com



