

Concrete Mixer

DBM 2500 - DBM 3500





- Not Available
 ● Standard
 ○ Optional

PERFORMANCE AND FEATURES	DBM 2500EE	DBM 3500EE	
Performance			
Unladen weight (lb)	15542	16314	
Concrete yield capacity (gal)	660	925	
Drum volume (gal)	925	1321	
Loading bucket volume (gal)	185	185	
Water pump capacity (gal/min)	66	66	
Water tank capacity (gal)	246	246	
Maximum unloading height without discharge chute (inch)	70	81	
Drum rotation speed (tr/min)	0 ÷ 26	0 ÷ 18	
PowerTrain			
Engine	DEUTZ TCD3.6	DEUTZ TCD3.6	
Engine power (kW/HP)	74.4/100	74.4/100	
Anti-pollution technology	TIER 3	TIER 3	
Fuel tank capacity (gal)	52.8	52.8	
AdBlue tank capacity (gal)	4.8	4.8	
Axles	Drop portal	Drop portal	
Brakes	Automatic parking brake		
Maximum gradeability: Fully laden (%)	45	40	
Maximum gradeability: Empty (%)	55	50	
Maximum transversal slope (%)	15	15	
Maximum speed (mph)	25	25	
Configuration			
ROPS Cab	●	●	
Double driving position	●	●	
Hydrostatic transmission	EPD	EPD	
Number of gears	2	2	
Permanent four-wheel drive	●	●	
All wheel steering	●	●	
Three steering way	●	●	
Standard tyres	405/70-20	500/45-20	
Front and rear towing hooks	●	●	
Two extension chutes	●	●	
Ground control panel	●	●	

Dimensions



	DBM 2500	DBM 3500
A (inch)	244.9	255.1
B (inch)	69.3	81.1
C (inch)	108.3	108.3
D (inch)	206.7	215.0
E (inch)	53.1	53.1
F (inch)	18.5	17.1
F1 (inch)	18.5	17.1
H (inch)	90.6	92.7
L (inch)	90.6	90.6
O (inch)	110.4	109.1
O1 (inch)	117.1	115.7
N (inch)	146.5	152.8
P (inch)	114.2	122.0
R (inch)	164.0	165.4
S (inch)	173.2	186.2
T (inch)	141.3	141.3
V (inch)	63.8	63.8

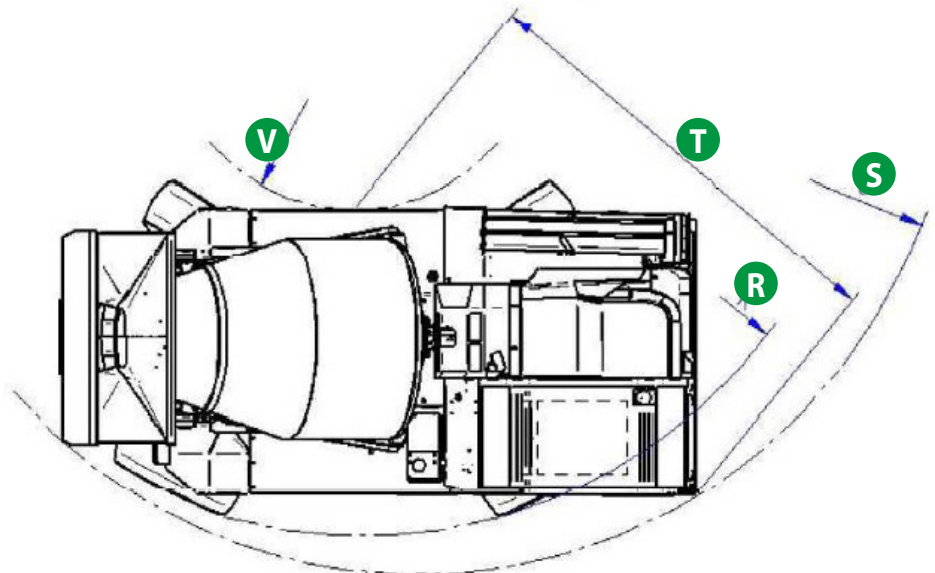
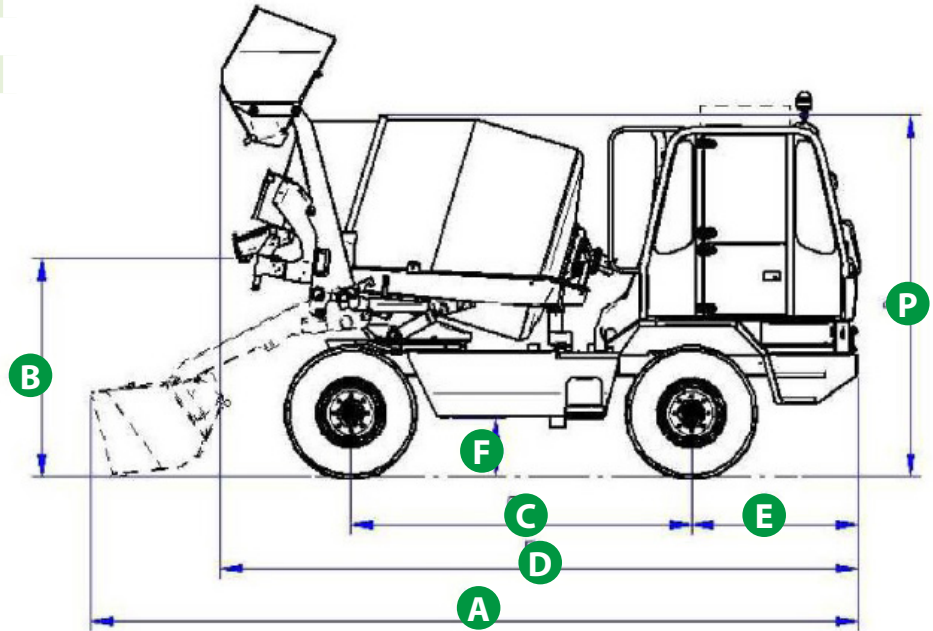
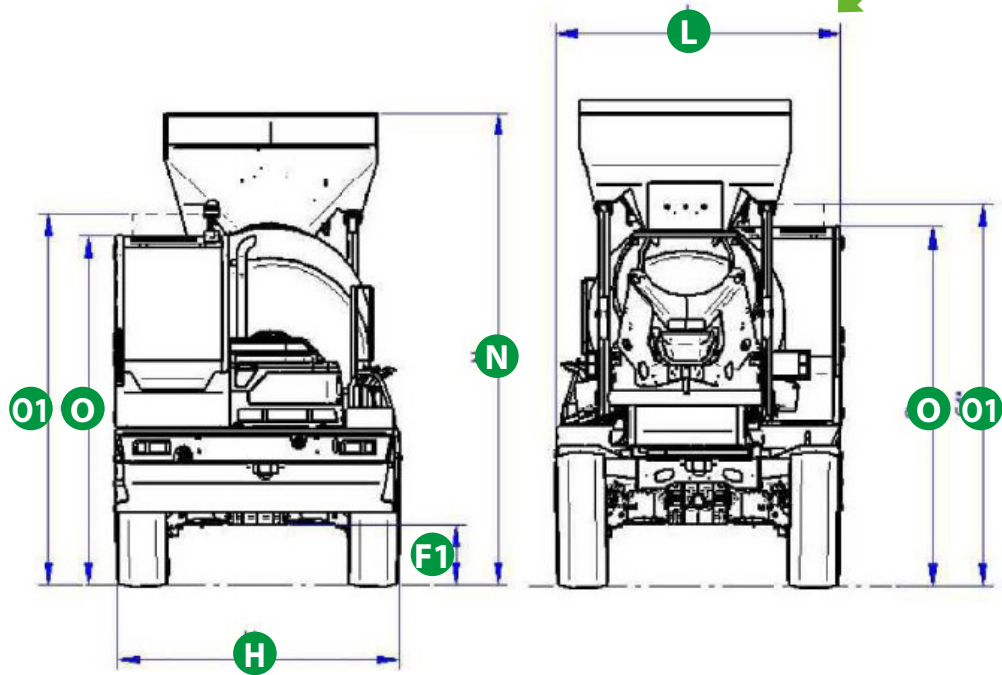

Your Merlo dealer

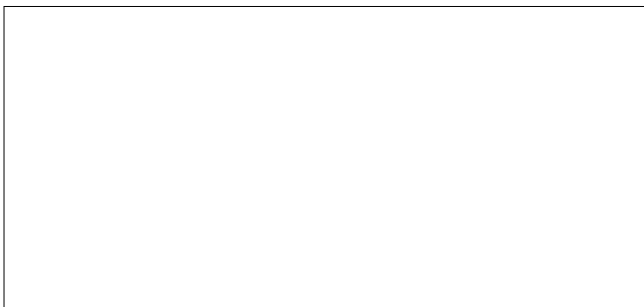

DBM2500EE:

MA00790 - VIN: D0004583 - SAV: D047551 - 19/01/2021

DBM3500EE:

MA00784 - VIN: D0000322 - SAV: D003451 - 12/05/2020

MERLO S.P.A.

Via Nazionale, 9

12010 S. Defendente di Cervasca, (Cuneo) Italia

Tel. +39 0171 614111

Fax +39 0171 684101

info@merlo.com

www.merlo.com

