

Dumper

DM9





PRESTACIONES Y CARACTERÍSTICAS	DM9		
Prestaciones			
Masa total en vacío (kg)	6500		
Capacidad de carga máxima (kg)	9000		
Volumen colmado iso6483 (m3)	4.9		
Volumen al ras (m3)	3.7		
Volumen agua (m3)	2.9		
Ángulo de volteo máx.	75°		
Rotación acoplamiento	± 90°		
Altura de descarga (mm)	1200		
PowerTrain			
Motor	DEUTZ TCD3.6		
Potencia del motor (kW/HP)	74.4/100		
Tecnología anti-contaminación	STAGE V		
Depósito de combustible (l)	200		
Depósito de AdBlue (l)	18		
Ejes	A portal		
Transmisión hidrostática	EPD		
Pendiente máxima superable a plena carga (%)	40		
Pendiente máxima superable en vacío (%)	50		
Pendiente máxima transversal (%)	15		
Velocidad máxima (km/h)	40		
Número de marchas	2		
Configuración			
Cabina FOPS/ROPS	●		
Doble posición de conducción	●		
Frenos	4 de discos secos		
Freno de estacionamiento	●		
Cuatro ruedas motrices	●		
Cuatro ruedas directrices	●		
Tres tipos de dirección	●		
Neumáticos estándar	18-19,5"		
Ganchos de arrastre delantero y trasero	●		
Desconector de batería automático.	●		
Batería	100Ah - 12V		
Compartimientos porta-herramientas	2		
Cámara trasera	●		
Aire acondicionado	○		
Faros de trabajo	○		

- not Available
● de serie
○ bajo pedido

Dimensiones



	DM9	
A (mm)	4920	
B (mm)	2100	
C (mm)	2750	
D (mm)	820	
E (mm)	880	
F (mm)	500	
F1 (mm)	495	
G (mm)	1885	
H (mm)	2335	
I (mm)	1200	
L (mm)	2200	
M (mm)	2630	
N (mm)	4130	
O (mm)	3020	
P (mm)	4010	
Q (mm)	250	
R (mm)	4190	
S (mm)	4730	

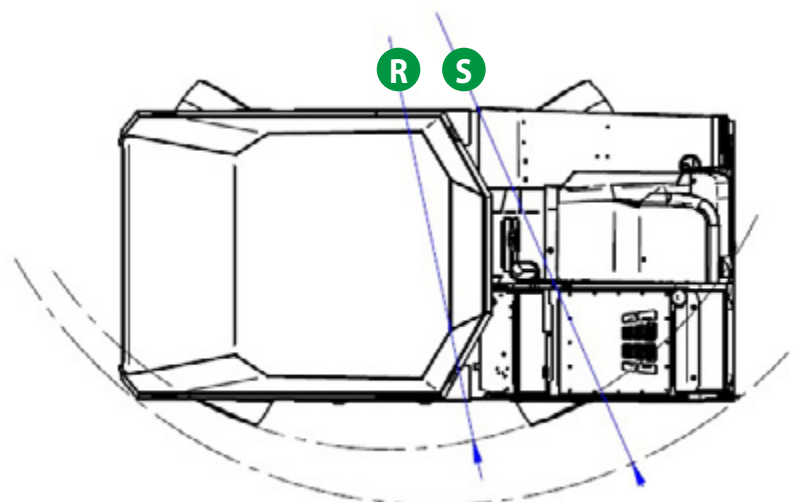
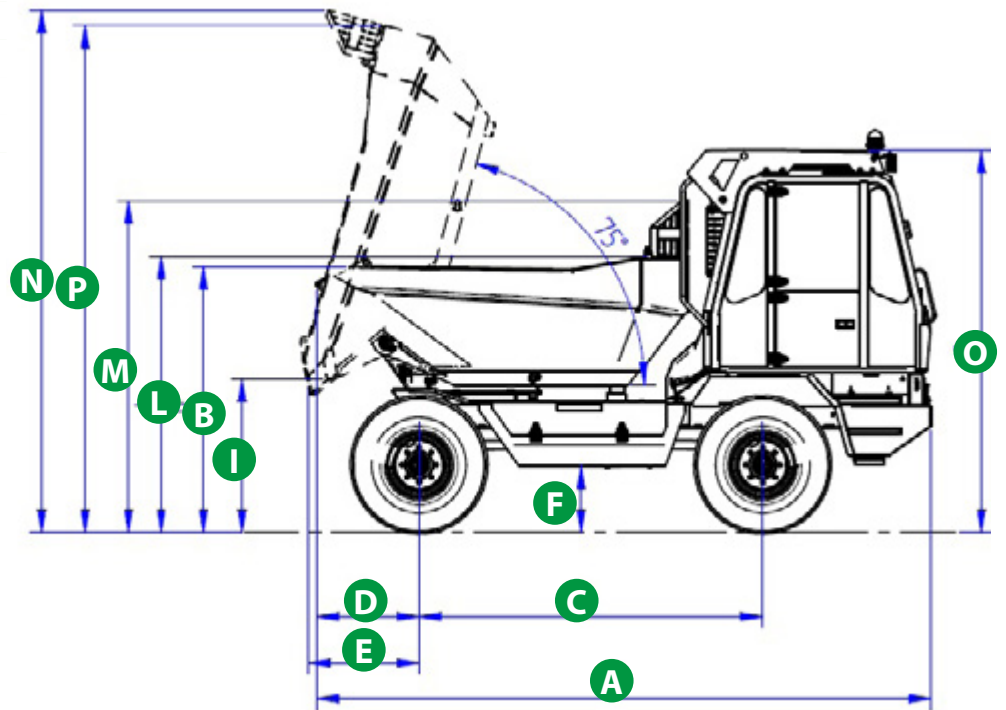
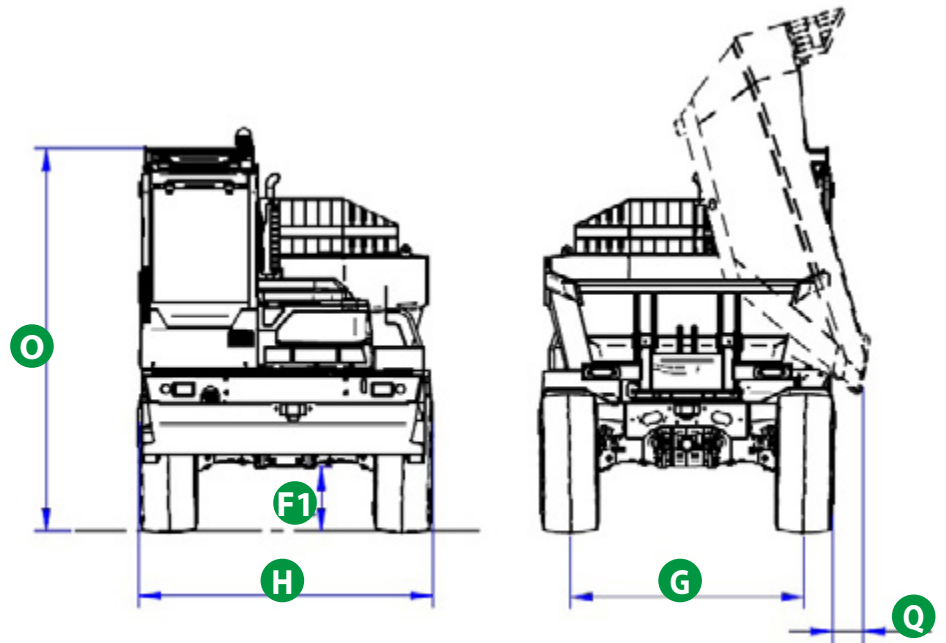

Vuestro concesionario Merlo

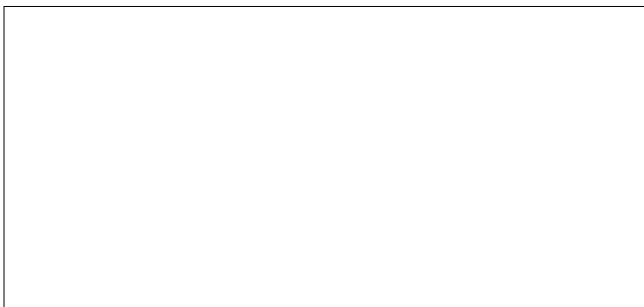

MERLO S.P.A.

Via Nazionale, 9

12010 S. Defendente di Cervasca, (Cuneo) Italia

Tel. +39 0171 614111

Fax +39 0171 684101

info@merlo.com

www.merlo.com

