



INSTALLATION INSTRUCTIONS FOR PART 95-5822

APPLICATIONS

Ford F-150 2009-2010, Lariat/King Ranch/ Platinum/XLT models with 6 buttons (not for NAV equipped) 95-5822 Series

KIT FEATURES

- Double DIN radio provision
- Stacked ISO radio provision
- *Painted or wood grain: 95-5822B - Black, 95-5822MM Lariat - Milano maple, 95-5822CM King Ranch - Curly maple, 95-5822AS Platinum - Ash satin*



KIT COMPONENTS

- A) Double DIN radio housing
- B) Radio housing trim panel
- C) Double DIN radio housing brackets
- D) (6) "U" style panel clips

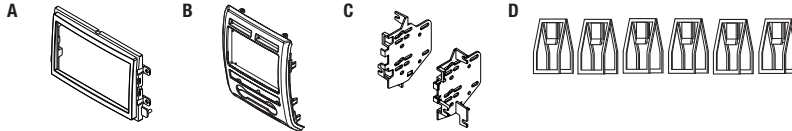

WIRING & ANTENNA CONNECTIONS (sold separately)

- Wiring Harness: • XVSI-5220-NAV • XVSI-5521-NAV • AX-ADBOX2 interface • AX-ADFD02 harness
 Antenna Adapter: • 40-CR10 - Chrysler antenna adapter 2002-up

TOOLS REQUIRED

- Cutting tool • Phillips screwdriver • Socket wrench • Torx driver • Panel removal tool

Table of Contents

Dash Disassembly

- Ford F-150 2009-2010 2

Kit Preparation

- Ford F-150 2009-2010 3

Kit Assembly

- Double DIN radio provision 4
- Stacked ISO radio provision..... 4

CAUTION: Metra recommends disconnecting the negative battery terminal before beginning any installation. All accessories, switches, and especially air bag indicator lights must be plugged in before reconnecting the battery or cycling the ignition.

NOTE: Refer to the instructions included with the aftermarket radio.

Ford F-150 2009-2010

1. Unclip and remove the switch panel to the right of the cigarette lighter then remove the (1) 9/32" screw exposed. (Figure A)
 2. Remove the rubber pad at the top of the radio trim panel then remove the (2) 9/32" screws exposed. (Figure B)
 3. Unclip and pull the side panels containing the A/C vents away from the radio trim panel.
- Note:** It is not necessary to remove the panels completely. (Figure C)
4. Unclip and remove the radio trim panel. (Figure D)
 5. Unclip and remove the hazard/airbag switch and driver info switch assemblies from the factory radio trim panel. (Figure E)

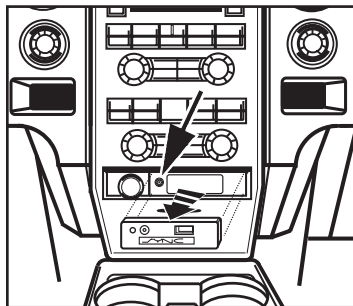

(Figure A)

6. Unclip and remove the cigarette lighter socket from the radio trim panel. (Figure F)
7. Remove (4) Torx screws securing the factory climate control to the radio trim panel. (Figure G)
8. Remove (4) 9/32" screws to remove the factory radio.

Continued to kit preparation

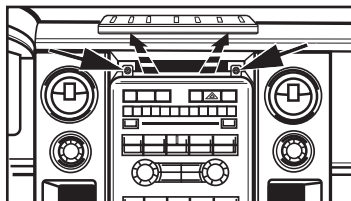

(Figure B)

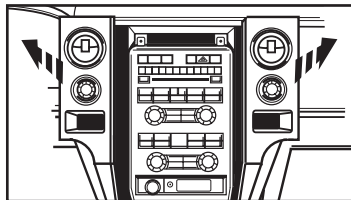

(Figure C)

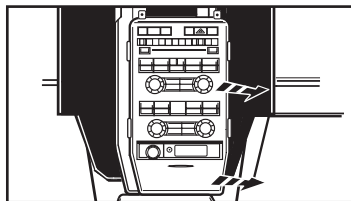

(Figure D)

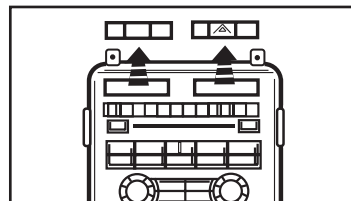

(Figure E)

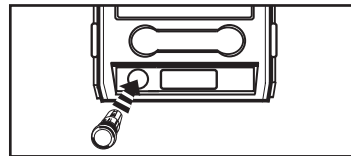

(Figure F)

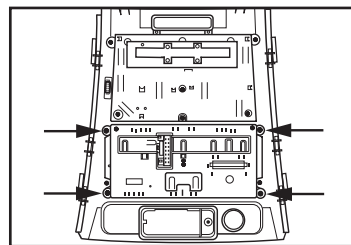

(Figure G)

Ford F-150 2009-2010

1. Clip the hazard/airbag switch and driver info switch assemblies into the radio housing in the same location as the factory radio trim panel. (Figure A)
2. Clip the cigarette lighter socket into the radio housing in the same location as the factory radio trim panel. (Figure B)
3. Secure the climate control into the radio housing using the factory hardware in the same location as the factory radio trim panel. (Figure C)
4. Attach the (6) "U" style panel clips to the radio housing in the same location as the factory radio trim panel. (Figure D)

Continued to kit assembly

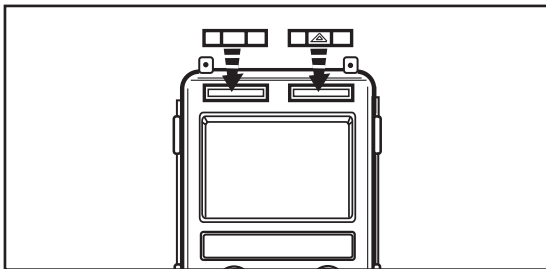

(Figure A)

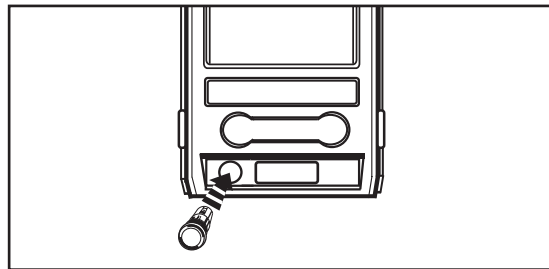

(Figure B)

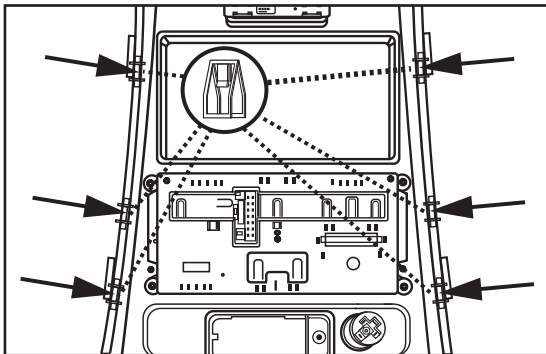

(Figure C)

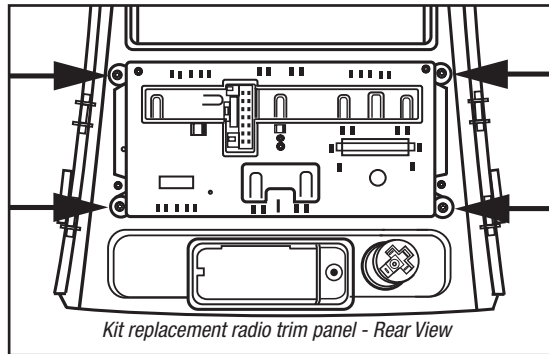

(Figure D)

Kit replacement radio trim panel - Rear View



INSTALLATION INSTRUCTIONS FOR PART 95-5822



Kit Assembly 95-5822

Double DIN or Stacked ISO radio provision

1. Slide the appropriate side bracket over the mounting legs of the Double DIN trim plate aligning the holes in the trim plate and the bracket and rotate inward.

Note: The notch in the housing should be on top. (Figure A)

2. Slide the Double DIN or stacked ISO mount units into the bracket/radio housing assembly and secure the Double DIN or stacked ISO mount units to the assembly using the screws supplied with the Double DIN or stacked ISO mount units. (Figure B)

3. Cut and remove half of the top (2) mounting legs with the brackets attached. (Figure C)
4. Locate the factory wiring harness in the dash. Metra recommends using the proper mating adapter from Metra or AXCESS. Re-connect the negative battery terminal and test the unit for proper operation.
5. Reassemble dash in reverse order of disassembly.

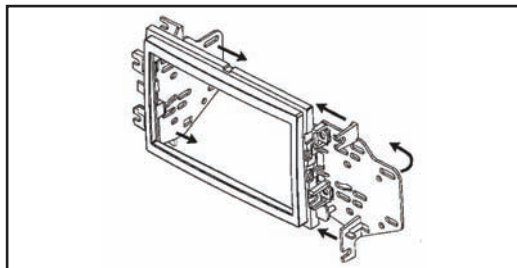

(Figure A)

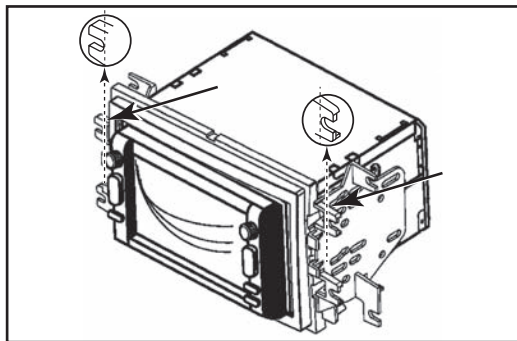

(Figure C)

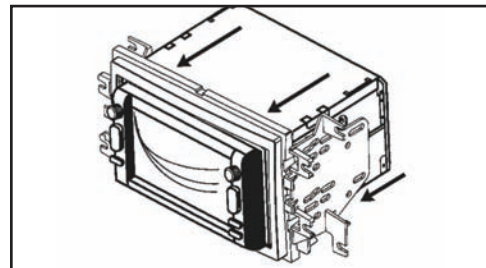

(Figure B)



KNOWLEDGE IS POWER

Enhance your installation and fabrication skills by enrolling in the most recognized and respected mobile electronics school in our industry. Log onto www.installerinstitute.com or call 800-354-6782 for more information and take steps toward a better tomorrow.

**Metra recommends MECP
certified technicians**



INSTRUCCIONES DE INSTALACIÓN PARA LA PIEZA 95-5822

APLICACIONES

Ford F-150 2009-2010, Lariat/King Ranch/ Platinum/XLT modelos con 6 botones (no para equipamiento NAV) Serie 95-5822

CARACTERÍSTICAS DEL KIT

- Provisión de radio doble DIN
- Provisión de radio ISO vertical
- *Pintado o grano de madera: 95-5822B - Negro, 95-5822MM Lariat - Arce Milano, 95-5822CM King Ranch - Arce rizado, 95-5822AS Platinum - Fresno satinado*



COMPONENTES DEL KIT

- A) Carcasa de radio doble DIN • B) Panel de moldura de la carcasa del radio
- C) Soportes doble DIN de la carcasa del radio • D) (6) ganchos del panel estilo "U"

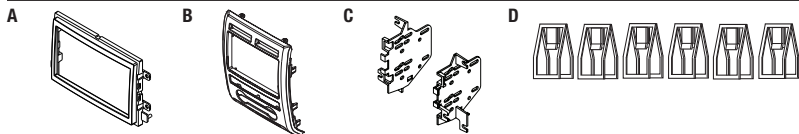

CABLEADO Y CONEXIONES DE ANTENA (se venden por separado)

Arnés de cableado: • XVSI-5220-NAV • XVSI-5521-NAV • AX-ADBOX2 interfaz • AX-ADFD02 arnés

Adaptador de antena: • 40-CR10 - Chrysler adaptador de antena 2002 y mas

HERRAMIENTAS REQUERIDAS

- Cortador • Destornillador Phillips • Llave de tubo • Destornillador Torx • Herramienta de remoción de panel

Indice

Desmontaje del tablero	
– Ford F-150 2009-2010	2
Preparación del kit	
– Ford F-150 2009-2010	3
Ensamble del kit	
– Provisión de radio doble DIN.....	4
– Provisión de radio ISO vertical	4

PRECAUCIÓN: Metra recomienda desconectar el terminal negativo de la batería antes de comenzar cualquier instalación. Todos los accesorios, interruptores y, especialmente, las luces indicadoras de airbag deben estar enchufados antes de volver a conectar la batería a comenzar el ciclo de ignición.

NOTA: Remítase a las instrucciones incluidas con el radio de postventa.

Ford F-150 2009-2010

1. Desenganche y quite el panel de interruptores a la derecha del encendedor de cigarrillos y luego quite el tornillo de 9/32" que queda a la vista. (Figura A)
2. Quite la almohadilla de caucho de la parte superior del panel de la moldura del radio y luego quite los (2) tornillos de 9/32" que quedan a la vista. (Figura B)
3. Desenganche y jale los paneles laterales que contienen las rejillas del aire acondicionado, retirándolas del panel de la moldura del radio. (Figura C)

Nota: No es necesario quitar los paneles por completo. (Figura C)

4. Desenganche y quite el panel de la moldura del radio. (Figura D)
5. Desenganche y quite los ensambles del interruptor de las luces intermitentes/bolsa de aire

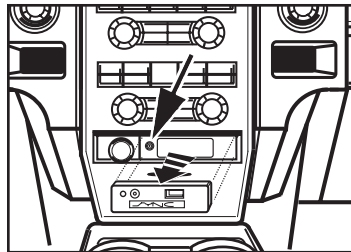

(Figura A)

y del interruptor de información para el conductor del panel de la moldura del radio de fábrica. (Figura E)

6. Desenganche y quite la cavidad del encendedor de cigarrillos del panel de moldura del radio. (Figura F)
7. Quite los (4) tornillos Torx que sujetan el control del clima al panel de la moldura del radio. (Figura G)
8. Quite los (4) tornillos de 9/32" para quitar el radio de fábrica.

Continuará la preparación del kit

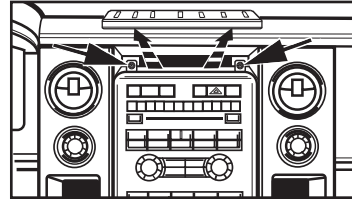

(Figura B)

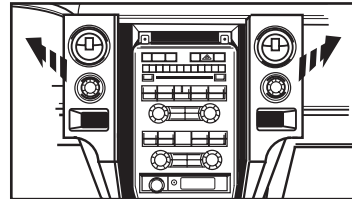

(Figura C)

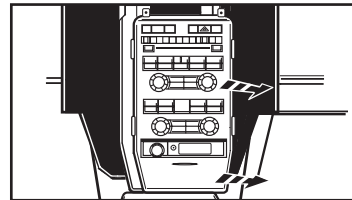

(Figura D)

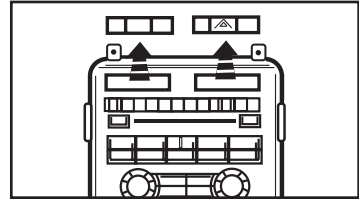

(Figura E)

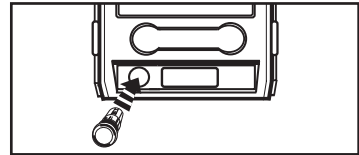

(Figura F)

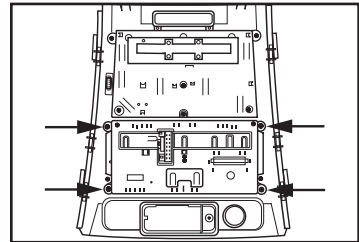

(Figura G)

Ford F-150 2009-2010

1. Enganche los ensamblados del interruptor de las luces intermitentes/bolsa de aire y del interruptor de información para el conductor en la carcasa del radio, en el mismo lugar que el panel de la moldura del radio de fábrica. (Figura A)
2. Enganche la cavidad del encendedor de cigarrillos en la carcasa del radio, en el mismo lugar que el panel de la moldura del radio de fábrica. (Figura B)
3. Asegure el control de clima a la carcasa del radio usando la tornillería de fábrica en el mismo lugar que el panel de la moldura del radio de fábrica. (Figura C)
4. Coloque los (6) ganchos de panel estilo "U" en la carcasa del radio, en el mismo lugar que el panel de la moldura del radio de fábrica. (Figura D)

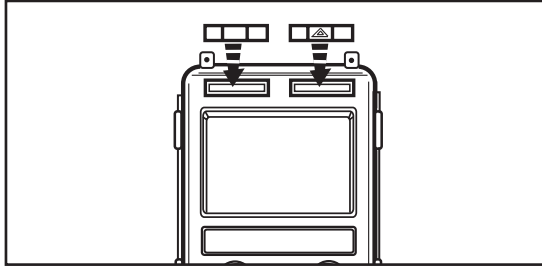

(Figura A)

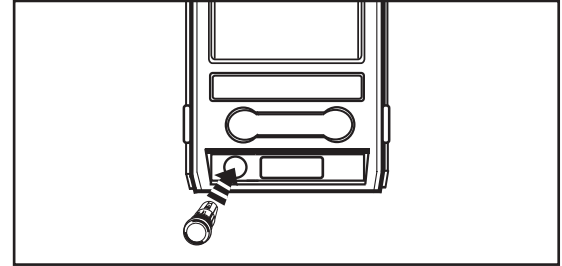

(Figura B)

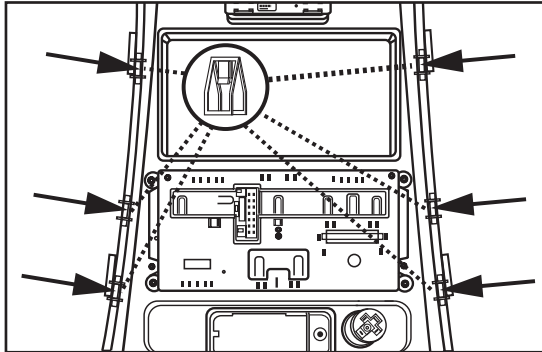

(Figura C)

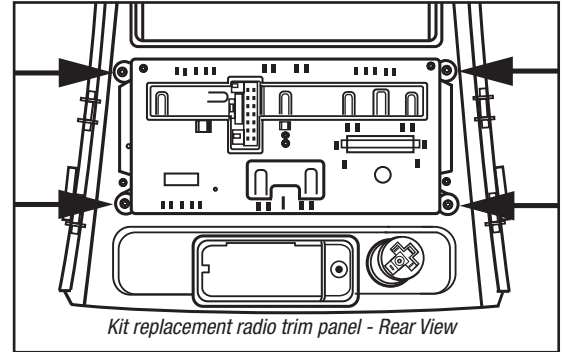

(Figura D)

Continuará al ensamble del kit

**Ensamble del kit 95-5822****Provisión de radio doble DIN o ISO vertical**

1. Deslice el soporte lateral correspondiente sobre las patas de montaje de la placa de moldura doble DIN, alineando los orificios de la placa de la moldura y el soporte, y gire hacia adentro.

Nota: La muesca de la carcasa debe estar en la parte superior. (Figura A)

2. Deslice las unidades de montaje doble DIN o ISO vertical en el ensamble del soporte/carcasa del radio y sujete las unidades de montaje doble DIN o ISO vertical al ensamble utilizando los tornillos suministrados. (Figura B)
3. Corte y quite la mitad de las (2) patas superiores de montaje con los soportes adjuntos. (Figura C)
4. Ubique el arnés de cableado de fábrica en el tablero. Metra recomienda el uso de un adaptador adecuado de acoplamiento de Metra o de AXCESS. Vuelva a conectar la terminal negativa de la batería y pruebe la unidad para verificar que funcione correctamente.
5. Vuelva a armar el tablero al revés de como lo desarmó.

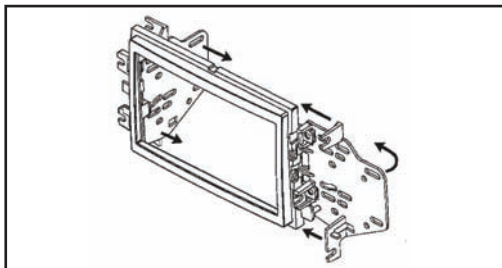

(Figura A)

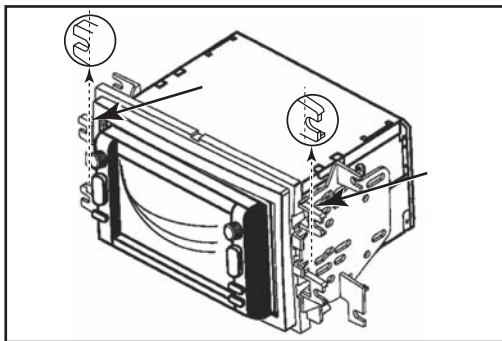

(Figura C)

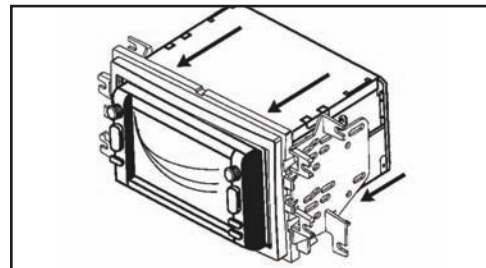

(Figura B)

EL CONOCIMIENTO ES PODER

Mejore sus habilidades de instalación y fabricación inscribiéndose en la escuela de dispositivos electrónicos móviles más reconocida y respetada de nuestra industria. Regístrese en www.installerinstitute.com o llame al 800-354-6782 para obtener más información y avance hacia un futuro mejor.



Metra recomienda técnicos con certificación del Programa de Certificación en Electrónica Móvil (Mobile Electronics Certification Program, MECP).