



Ford

F-150 (with CD player, w/o color screen) **2013-2014**

F-150 XL (with CD player) **2009-2013**

F-150 XLT (with single row of 3 buttons, w/o NAV) **2009-2012**

Visit MetraOnline.com for more detailed information about the product and up-to-date vehicle specific applications

KIT FEATURES

- DIN radio provision with pocket
- ISO DIN radio provision with pocket

KIT COMPONENTS

- A) Radio housing • B) Radio housing brackets • C) Climate/radio trim panel • D) ISO brackets • E) ISO trim plate • F) (6) Panel clips

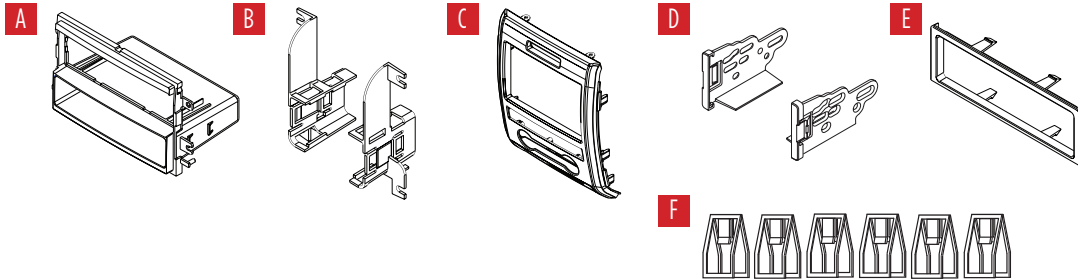

TABLE OF CONTENTS

Dash Disassembly	2
Kit Preparation.....	3-4
Kit Assembly	
–DIN radio provision with pocket	5
–ISO DIN radio provision with pocket.....	6

WIRING & ANTENNA CONNECTIONS (sold separately)

Wiring Harness: Visit axssinterfaces.com for harness and interface options.
Antenna Adapter: 40-CR10

TOOLS REQUIRED

- Cutting tool • Phillips screwdriver
- 9/32" socket wrench • Torx screwdriver
- Panel removal tool

Attention! With the key out of the ignition, disconnect the negative battery terminal before installing this product. Ensure that all installation connections are secure before cycling the ignition to test this product.

DASH DISASSEMBLY

1. Unclip and remove the switch panel to the right of the cigarette lighter, then remove (1) 9/32" screw exposed. (Figure A)
2. Remove the rubber pad at the top of the climate/radio panel, then remove (2) 9/32" screws exposed. (Figure B)

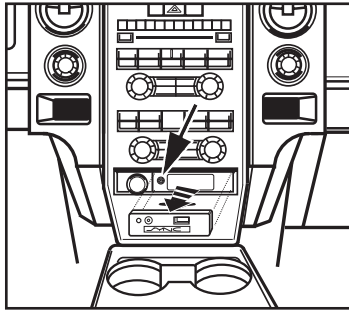

(Figure A)

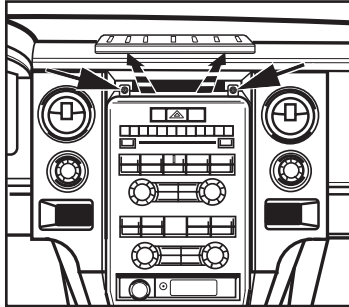

(Figure B)

3. Unclip the a/c vent panels to the left and right of the climate/radio panel and set aside. (Figure C)
4. Unclip, unplug, and remove the climate/radio panel. (Figure D)
5. Remove (4) 9/32" screws securing the radio chassis. Slide the chassis out, then unplug and remove.

Continue to Kit Preparation

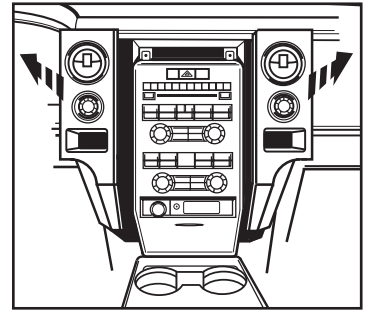

(Figure C)

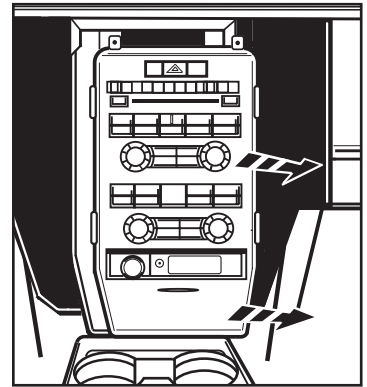

(Figure D)

KIT PREPARATION

From the factory climate/radio panel:

1. Unclip and remove the hazard/airbag switch assembly from the factory radio trim panel. (Figure A)
2. Unclip and remove the cigarette lighter socket from the radio trim panel. (Figure B)
3. Remove (4) Torx screws securing the factory climate control to the radio trim panel. (Figure C)

Continued on the next page

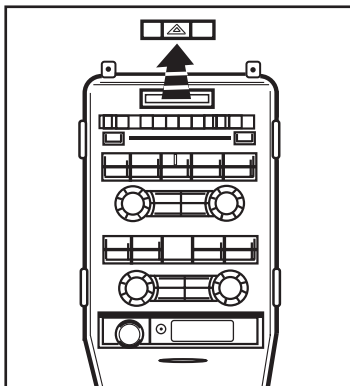

(Figure A)

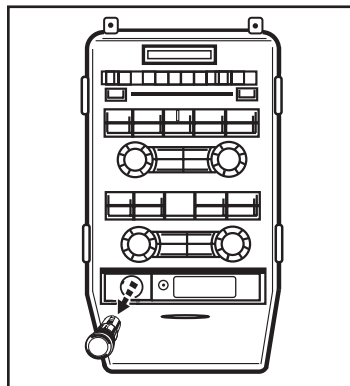

(Figure B)

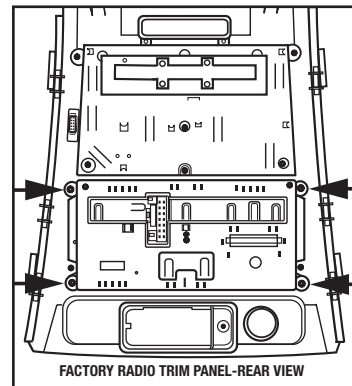

(Figure C)

KIT PREPARATION (CONT.)

To the 99-5820 radio trim panel:

4. Clip the hazard/airbag switch assembly into the panel. (Figure D)
5. Clip the cigarette lighter socket into the panel. (Figure E)
6. Secure the climate control to the panel using the factory screws. (Figure F)
7. Attach (6) panel clips provided to the panel. (Figure G)

Continue to Kit Assembly

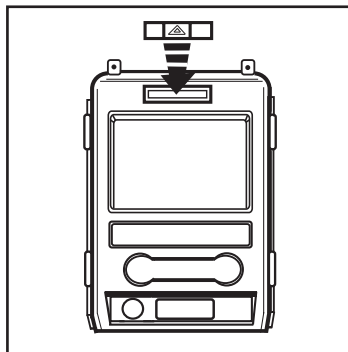

(Figure D)

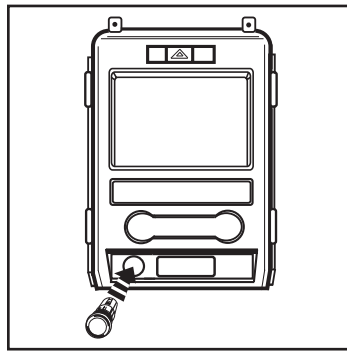

(Figure E)

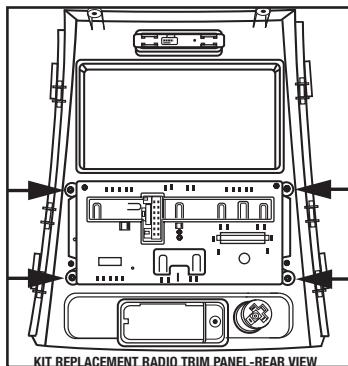

(Figure F)

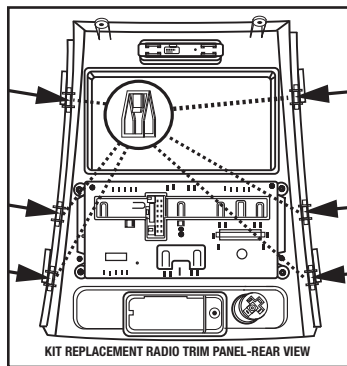

(Figure G)

KIT ASSEMBLY

DIN radio provision with pocket

1. Cut off and remove the top (2) mounting legs from the radio housing. (Figure A)

Note: The notch in the housing should be on top.

2. Slide the **radio housing brackets** onto the sides of the **radio housing** until they clip in. (Figure B)
3. Remove the metal DIN sleeve from the aftermarket radio.
4. Slide the sleeve into the **radio housing** and secure by bending the metal locking tabs down. (Figure C)
5. Slide the radio back into the sleeve until it clicks in. (Figure D)
6. Locate the factory wiring harness and antenna connector in the dash. Metra recommends using the proper mating adapter from Metra or AXCESS. Complete all connections to the radio and vehicle, then test the radio and vehicle for proper operation.
7. Slide the completed radio assembly into the dash and secure using the factory screws.
8. Reassemble the dash in reverse order of disassembly using the 99-5820 **radio trim panel** to complete the installation.

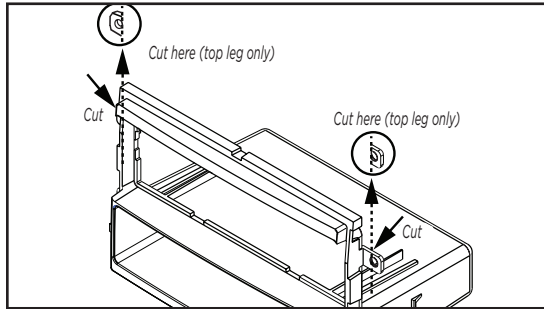

(Figure A)

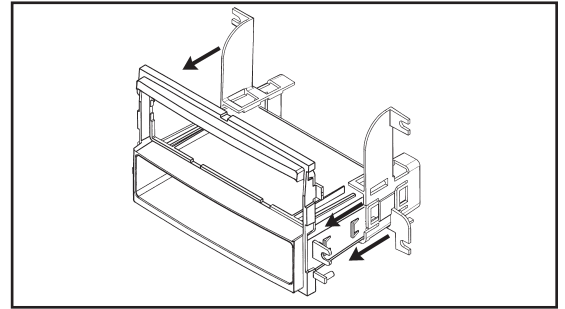

(Figure B)

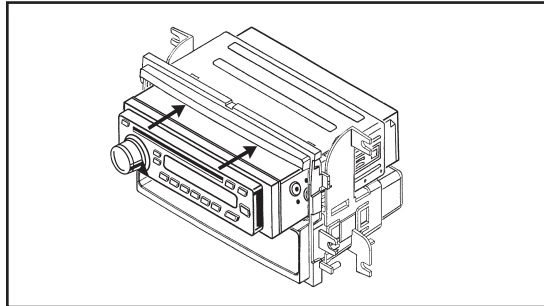

(Figure C)

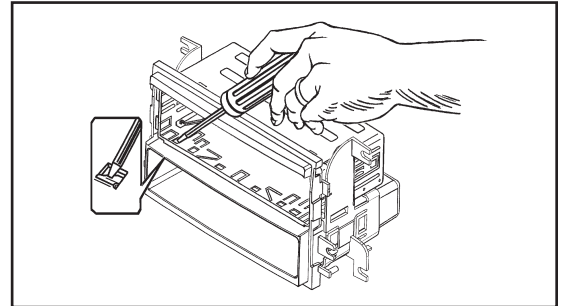

(Figure D)

KIT ASSEMBLY

ISO DIN radio provision with pocket

1. Cut off and remove the top (2) mounting legs from the radio housing. (Figure A)

Note: The notch in the housing should be on top.

2. Slide the **radio housing brackets** onto the sides of the **radio housing** until they clip in. (Figure B)
3. Remove the metal DIN sleeve and trim ring from the aftermarket radio.
4. Secure the **ISO brackets** to the radio using the screws supplied with the radio. (Figure C)

5. Slide the bracket/radio assembly into the **radio housing** until the side clips engage. Attach the **ISO trim plate** onto the completed assembly. (Figure D)
6. Locate the factory wiring harness and antenna connector in the dash. Metra recommends using the proper mating adapter from Metra or AXCESS. Complete all connections to the radio and vehicle, then test the radio and vehicle for proper operation.
7. Slide the completed radio assembly into the dash and secure using the factory screws.
8. Reassemble the dash in reverse order of disassembly using the 99-5820 **radio trim panel** to complete the installation.

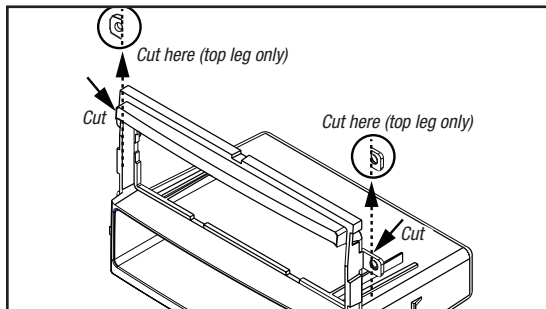

(Figure A)

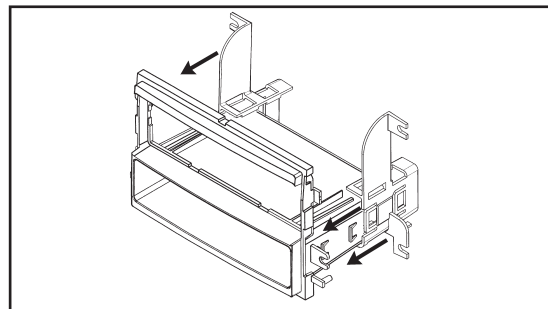

(Figure B)

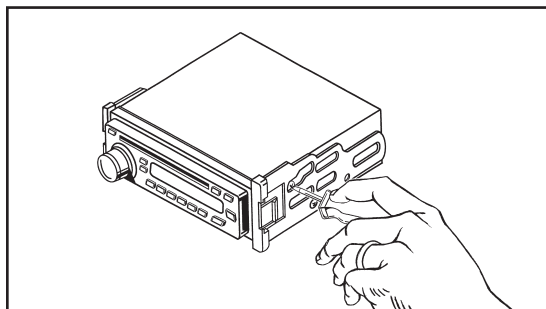

(Figure C)

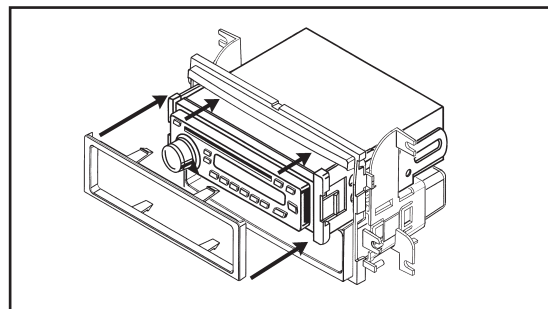

(Figure D)



99-5820
INSTALLATION INSTRUCTIONS



Having difficulties? We're here to help.



Contact our Tech Support line at:

386-257-1187



Or via email at:

techsupport@metra-autosound.com

Tech Support Hours (Eastern Standard Time)

Monday - Friday: 9:00 AM - 7:00 PM

Saturday: 10:00 AM - 5:00 PM

Sunday: 10:00 AM - 4:00 PM



**Metra recommends MECP
certified technicians**



Ford

F-150 (con reproductor de CD sin pantalla a color) **2013-2014**

F-150 XL (con reproductor de CD) **2009-2013**

F-150 XLT (con sola fila de 3 botones, sin NAV) **2009-2012**

Visite MetraOnline.com para obtener información más detallada sobre el producto y aplicaciones actualizadas específicas para vehículos.

CARACTERÍSTICAS DEL KIT

- Provisión de radio DIN con bolsillo
- Provisión de radio ISO DIN con bolsillo

COMPONENTES DEL KIT

- A) Carcasa de radio • B) Soportes de carcasa de radio • C) Panel de moldura de clima/radio • D) Soportes ISO • E) Placa de moldura ISO • F) Ganchos de panel (6)

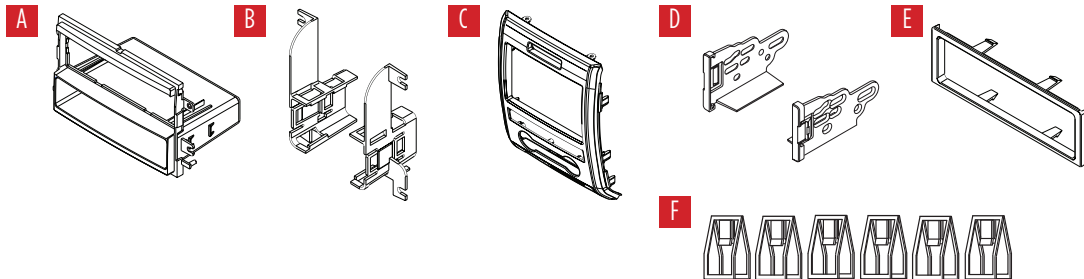

INDICE

Desmontaje del tablero	2
Preparación del kit	3-4
Ensamble del kit	5-6

CABLEADO Y CONEXIONES DE ANTENA

(se venden por separado)

Arnés de cableado: Visite axessinterfases.com para conocer las opciones de arneses e interfaces.

Adaptador de antena: 40-CR10

HERRAMIENTAS REQUERIDAS

- Herramienta de corte • Destornillador Phillips
- Llave de tubo 9/32" • Destornillador Torx
- Herramienta de remoción de panel

¡Precaución! Todos los accesorios, interruptores, paneles de controles de clima y especialmente las luces del indicador de las bolsas de aire deben estar conectados antes ciclar la ignición. Además, no quite el radio de fábrica con la llave en la posición o de encendido ni con el vehículo funcionando.

DESMONTAJE DEL TABLERO

1. Desenganche y quite el panel de interruptores a la derecha del encendedor de cigarrillos y luego quite el tornillo de 9/32" que queda a la vista. (Figura A)
2. Quite la almohadilla de caucho de la parte superior del panel de la clima/radio y luego quite los (2) tornillos de 9/32" que quedan a la vista. (Figura B)

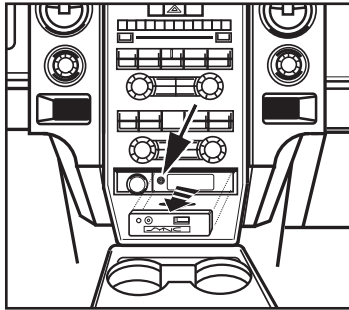

(Figura A)

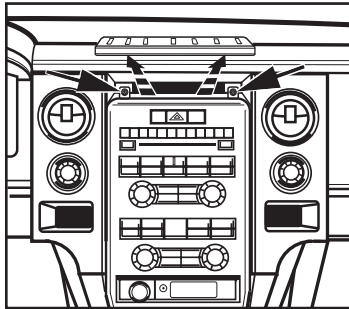

(Figura B)

3. Suelte los paneles de ventilación del aire acondicionado a la izquierda y la derecha del panel de clima/radio y póngalos a un lado. (Figura C)
4. Soltar, desenchufar y quitar el panel de clima/radio. (Figura D)
5. Quite los (4) tornillos de 9/32" que sujetan el chasis de la radio. Deslice el chasis hacia afuera, luego desenchufe y retire.

Continúe con la Preparación del Kit

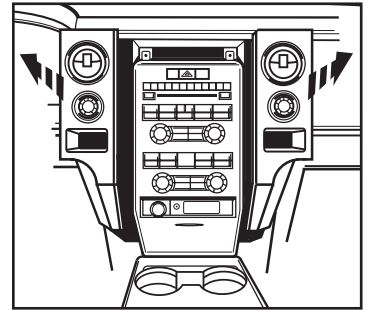

(Figura C)

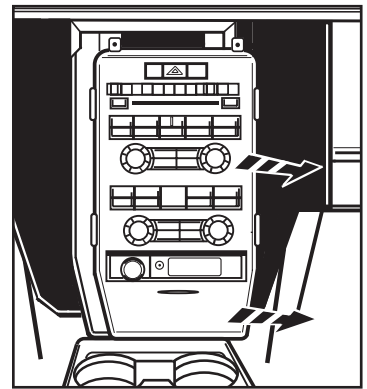

(Figura D)

PREPARACIÓN DEL KIT

Desde el panel de clima/radio de fábrica:

1. Suelte y retire el conjunto de interruptor de peligro / airbag del panel de ajuste de radio de fábrica. (Figura A)
2. Desenganche y retire el enchufe del encendedor de cigarrillos del panel de la radio. (Figura B)
3. Retire (4) los tornillos Torx que sujetan el control de clima de fábrica al panel de la radio. (Figura C)

Continúa en la siguiente página

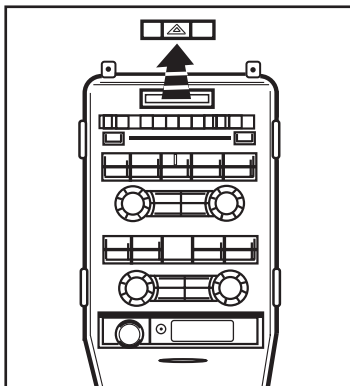

(Figura A)

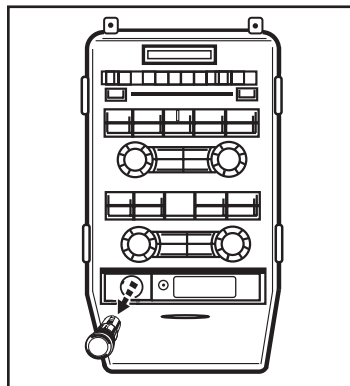

(Figura B)

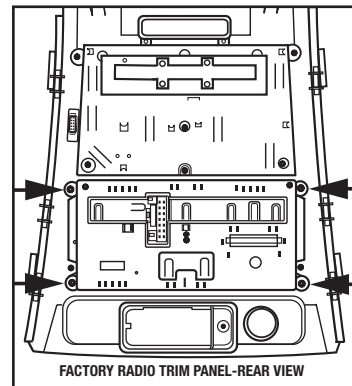

(Figura C)

PREPARACIÓN DEL KIT (CONT.)

Para el panel de ajuste de radio 99-5820:

4. Sujete el conjunto del interruptor de peligro / airbag en el panel. (Figura D)
5. Sujete el enchufe del encendedor de cigarrillos en el panel. (Figura E)
6. Fije el control del clima al panel usando los tornillos de fábrica. (Figura F)
7. Fije (6) los clips del panel provistos al panel. (Figura G)

Continúe con el Ensamble del Kit

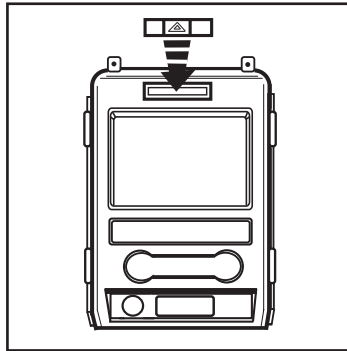

(Figura D)

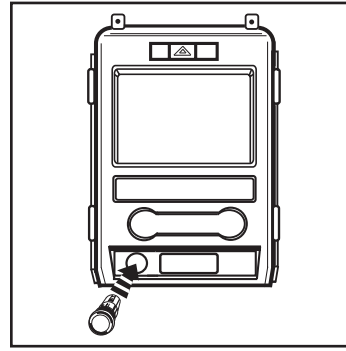

(Figura E)

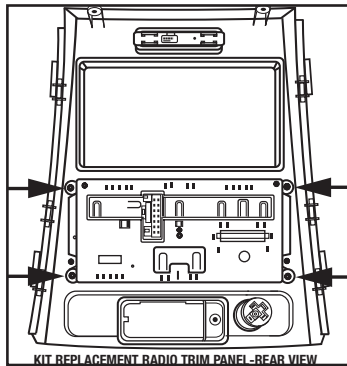

(Figura F)

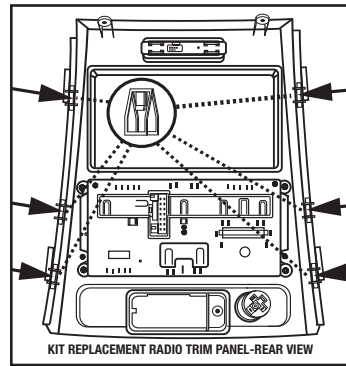

(Figura G)

ENSAMBLE DEL KIT

Provisión de radio DIN con bolsillo

1. Corte y retire las (2) patas de montaje superiores de **la carcasa de la radio**. (Figura A)

Nota: La muesca en la carcasa debe estar en la parte superior.

2. Deslice los **soportes de la carcasa de la radio** sobre los costados de la **carcasa de la radio** hasta que encajen. (Figura B)
3. Retire la funda DIN de metal de la radio de repuesto.
4. Deslice la funda dentro de la **carcasa de la radio** y asegúrela doblando las pestañas de bloqueo de metal hacia abajo. (Figura C)

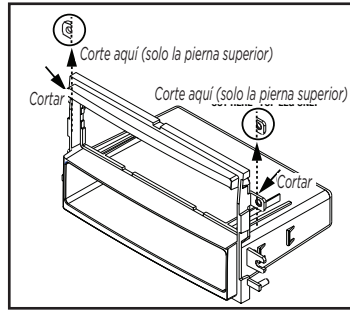

(Figura A)

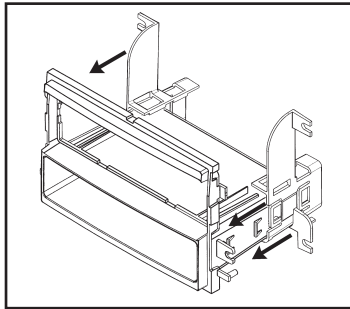

(Figura B)

5. Deslice la radio nuevamente dentro de la funda hasta que encaje. (Figura D)
6. Ubique el arnés de cableado de fábrica y el conector de antena en el tablero. Metra recomienda usar el adaptador de acoplamiento adecuado de Metra o AXCESS. Complete todas las conexiones a la radio y al vehículo, luego pruebe la radio y el vehículo para verificar que funcionen correctamente.
7. Deslice el conjunto de radio completo dentro del tablero y asegúrelo con los tornillos de fábrica.
8. Vuelva a ensamblar el tablero en el orden inverso al de desmontaje usando el **panel de moldura de radio 99-5820** para completar la instalación.

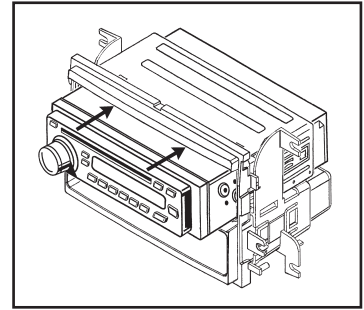

(Figura C)

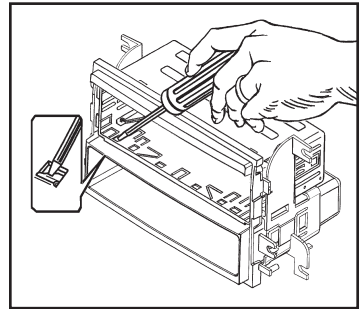

(Figura D)

ENSAMBLE DEL KIT

Provisión de radio ISO DIN con bolsillo

1. Corte y retire las (2) patas de montaje superiores de la carcasa de la radio. (Figura A)
Nota: La muesca en la carcasa debe estar en la parte superior.
2. Deslice los **soportes de la carcasa de la radio** sobre los costados de la **carcasa de la radio** hasta que encajen. (Figura B)
3. Retire la funda DIN de metal y el anillo de ajuste de la radio de repuesto.
4. Fije los **soportes ISO a la radio** con los tornillos que se incluyen con la radio. (Figura C)
5. Deslice el conjunto de soporte/radio en la **carcasa de la radio** hasta que encajen los clips laterales. Coloque la **placa de ajuste ISO** en el conjunto completo. (Figura D)

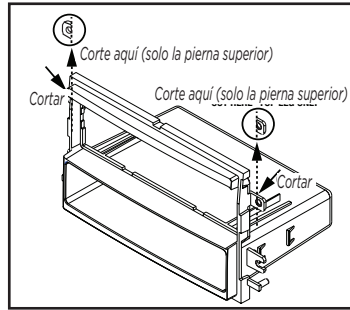

(Figura A)

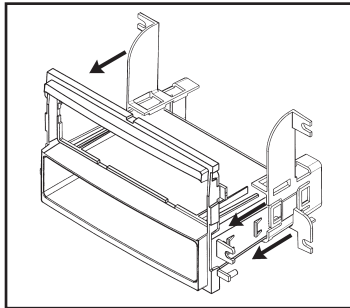

(Figura B)

6. Ubique el arnés de cableado de fábrica y el conector de antena en el tablero. Metra recomienda usar el adaptador de acoplamiento adecuado de Metra o AXCESS. Complete todas las conexiones a la radio y al vehículo, luego pruebe la radio y el vehículo para verificar que funcionen correctamente.
7. Deslice el conjunto de radio completo en el tablero y fíjelo con los tornillos de fábrica.
8. Vuelva a ensamblar el tablero en el orden inverso al de desmontaje utilizando el **panel de moldura de radio 99-5820** para completar la instalación.

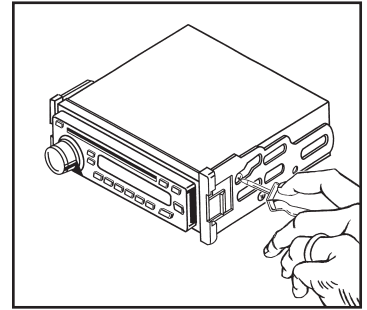

(Figura C)

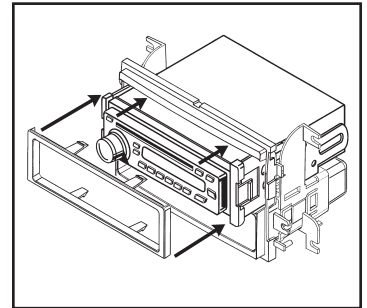

(Figura D)





99-5820
INSTRUCCIONES DE INSTALACIÓN



¿Tienes dificultades? Estamos aquí para ayudar.



Póngase en contacto con nuestra
línea de soporte técnico en:

386-257-1187



O por correo electrónico a:

techsupport@metra-autosound.com

Horas de soporte técnico (hora estándar del este)

Monday - Friday: 9:00 AM - 7:00 PM

Saturday: 10:00 AM - 5:00 PM

Sunday: 10:00 AM - 4:00 PM



**Metra recomienda MECP
técnicos certificados**