



## INSTALLATION INSTRUCTIONS FOR PART 99-7511S

### APPLICATIONS

# Mazda 6 2009-up 99-7511S

### KIT FEATURES

- DIN radio provision
- ISO mount radio provision
- Double DIN radio provision
- Stacked ISO mount radio provision
- *Painted silver to match factory dash*



### KIT COMPONENTS

- A) Radio Housing • B) ISO Brackets • C) ISO Trim Plate • D) Double DIN Brackets
- E) Double DIN Trim Plate • F) Pocket • G) Filler Trim Panel • H) (2) #3x3/8" Phillips Screws

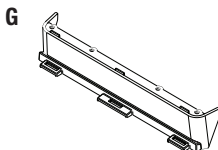
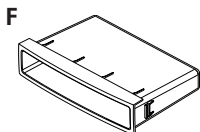
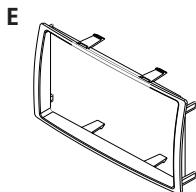
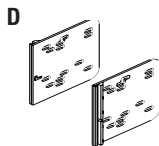
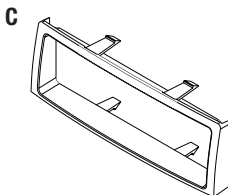
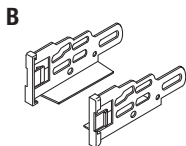
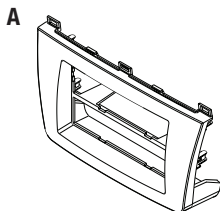

### TOOLS REQUIRED

Small Flat Blade Screwdriver • Panel Removal Tool • Phillips Screwdriver • Socket Wrench



**METRA. THE WORLD'S BEST KITS.™**



**1-800-221-0932**



**metraonline.com**

© COPYRIGHT 2004-2011 METRA ELECTRONICS CORPORATION



99-75115

## Table of Contents

### Dash Disassembly

– Mazda 6 2009-up.....3-4

### Kit Assembly

– DIN radio provision.....5-6  
– ISO mount radio provision .....7-8  
– DDIN/stacked ISO DIN head unit provision.....9-10

### Caution

*Metra recommends disconnecting the negative battery terminal before beginning any installation. All accessories, switches, and especially air bag indicator lights must be plugged in before reconnecting the battery or cycling the ignition.*

*\*NOTE: Refer also to the instructions included with the aftermarket radio.*



#### KNOWLEDGE IS POWER

Enhance your installation and fabrication skills by enrolling in the most recognized and respected mobile electronics school in our industry. Log onto [www.installerinstitute.com](http://www.installerinstitute.com) or call 800-354-6782 for more information and take steps toward a better tomorrow.



**Metra recommends MECP certified technicians**

## Dash Disassembly

1. Unclip and remove the cup holder/  
parking brake trim panel. (Figure A)
2. Unclip and remove the trim panel above  
the glove box and down the right side  
of the center console. (Figure B)
3. Unclip and remove the trim panel next  
to the key switch and down the left side  
of the center console. (Figure B)
4. Remove Shifter knob. (Figure A)
5. Unclip and remove the trim panel  
surrounding the climate controls and  
the shifter lever. (Figure C)

*Continued on next page*

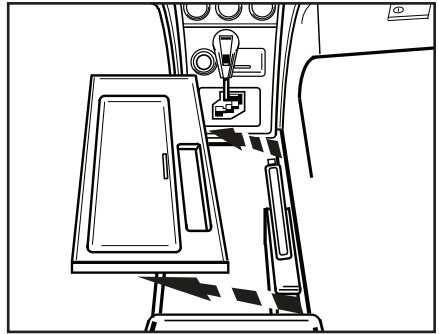

(Figure A)

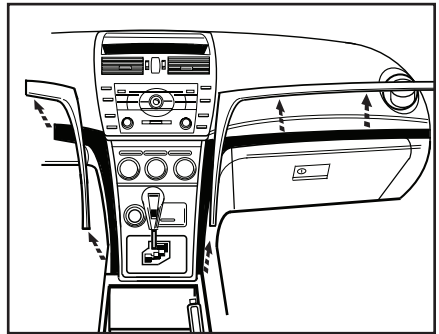

(Figure B)

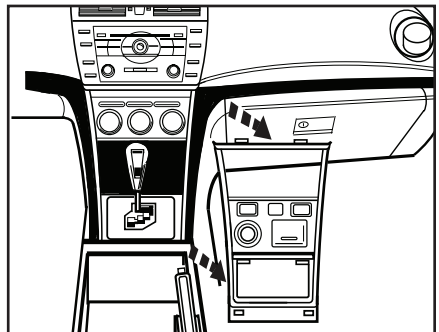

(Figure C)

## Dash Disassembly

6. Unclip and remove the vent panel above the radio. (Figure D)
7. Remove (4) screws securing the factory radio. Unplug and remove the radio.

*Continue to kit assembly*

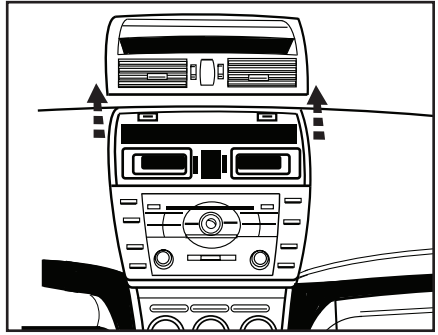

*(Figure D)*

## DIN radio provision

1. Locate the factory wiring harness in the dash. Metra recommends using the proper mating adapter from Metra or AXXESS. Re-connect the negative battery terminal and test the unit for proper operation.
2. Attach the filler trim panel to the back of the radio housing at the bottom edge. (Figure A)
3. Slide the DIN cage into the radio housing and secure by bending the metal locking tabs outward. (Figure B)
4. Slide the aftermarket radio into the DIN cage until it snaps into place. (Figure C)

*Continue to next page*

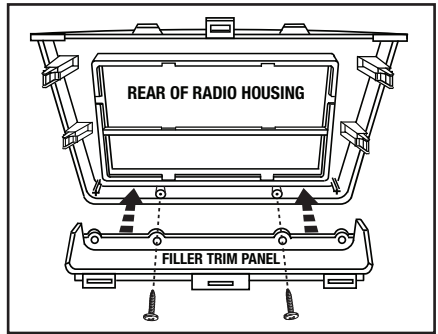

(Figure A)

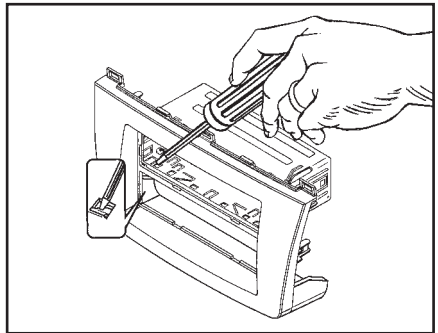

(Figure B)

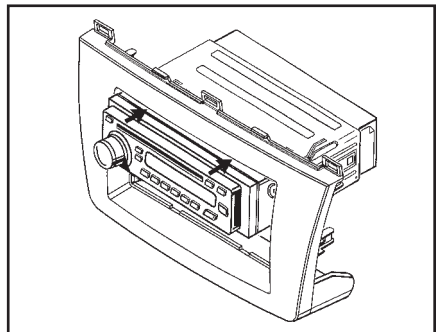

(Figure C)



## Kit Assembly 99-75115

### Din radio provision

2. Snap the pocket into the the bottom opening of the radio housing. (Figure D)
4. Reassemble dash in reverse order of disassembly.

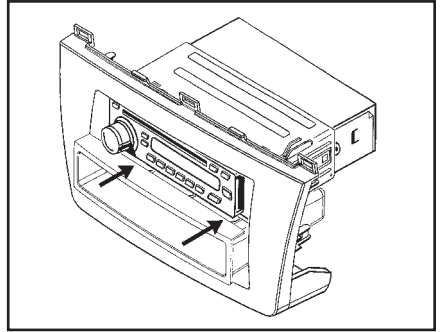

(Figure D)



## Kit Assembly 99-75115

### ISO mount radio provision

1. Locate the factory wiring harness in the dash. Metra recommends using the proper mating adapter from Metra or AXXESS. Re-connect the negative battery terminal and test the unit for proper operation.
2. Attach the filler trim panel to the back of the radio housing at the bottom edge. (Figure A)
3. Mount the ISO brackets to the radio using the screws supplied with the radio. (Figure B)
4. Slide the radio into the radio housing until it snaps into place. (Figure C)
5. Snap the trim plate onto the front of the radio housing. (Figure C)

*Continue to next page*

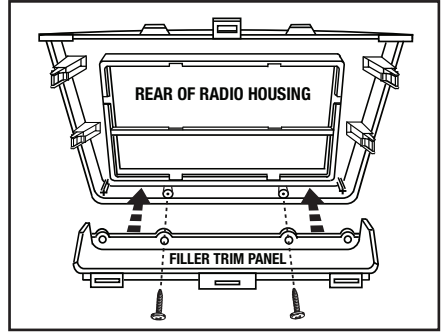

(Figure A)

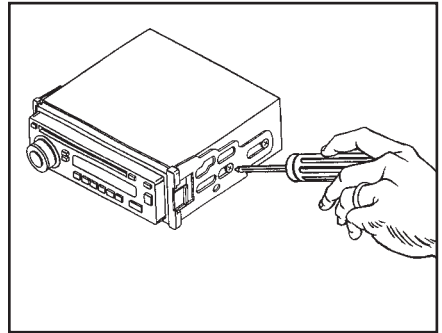

(Figure B)

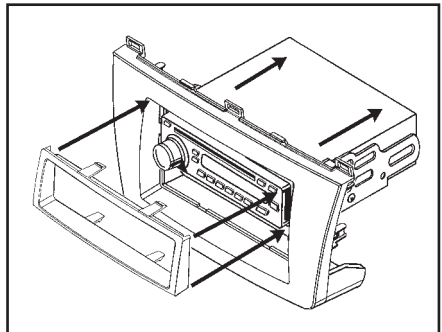

(Figure C)



## Kit Assembly 99-75115

### ISO mount radio provision

6. Snap the pocket into the bottom opening of the radio housing. (Figure D)
7. Reassemble dash in reverse order of disassembly.

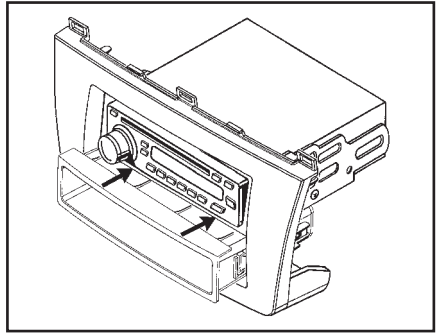

(Figure D)





## Kit Assembly 99-75115

### Double DIN/stacked ISO mount unit(s) provision

1. Locate the factory wiring harness in the dash. Metra recommends using the proper mating adapter from Metra or AXCESS. Re-connect the negative battery terminal and test the unit for proper operation.
2. Attach the filler trim panel to the back of the radio housing at the bottom edge. (Figure A)
3. Cut and remove the center bar from the radio housing. (Figure B)
4. Snap the double DIN brackets to the inside edge of the radio housing. (Figure C)

*Continue to next page*

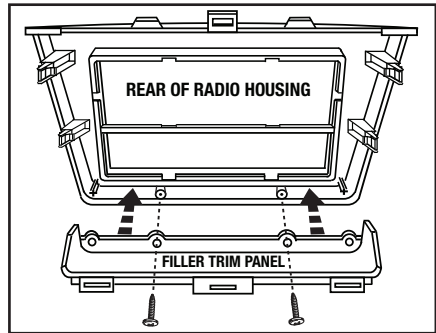

(Figure A)

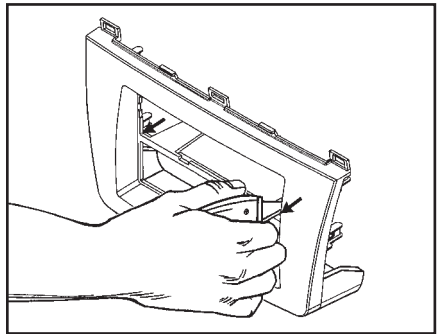

(Figure B)

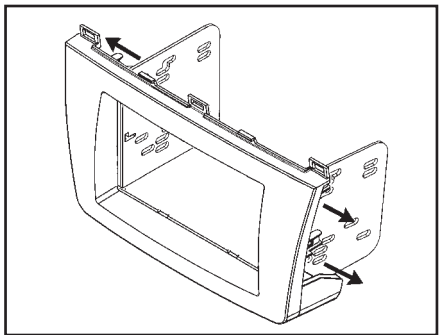

(Figure C)



## Kit Assembly 99-75115

### ISO mount radio provision

6. Slide the double DIN or stacked ISO mount unit(s) into the bracket/radio housing assembly and secure to the assembly using the screws supplied with the unit(s). Snap the DDIN trim plate onto the front of the radio housing. (Figure D)
7. Reassemble dash in reverse order of disassembly.

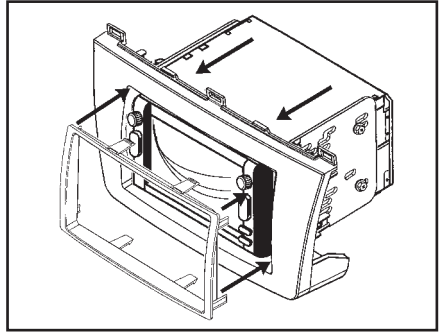

(Figure D)





**INSTALLATION INSTRUCTIONS FOR PART 99-7511S**

REV. 6/17/11

**METRA. THE WORLD'S BEST KITS.™**



**1-800-221-0932**



**metraonline.com**

© COPYRIGHT 2004-2011 METRA ELECTRONICS CORPORATION