



Radio Housing (b) shown installed

## Chrysler 1974-2010

### KIT FEATURES

- DIN radio provision

### INTRODUCTION

- The WM-FJCK01 includes two different radio housings to cover a broad range of vehicles. Use the **Application Overview** on page 2 to reference which radio housing to use, and also which instruction pages to follow. Each section is setup as a chapter with its own table of contents.

### KIT COMPONENTS

- A1) Radio housing (a) • A2) Support spacers (Avenger/Sebring) • B1) Radio housing (b)

A1

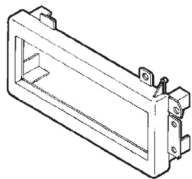

A2

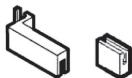

B1

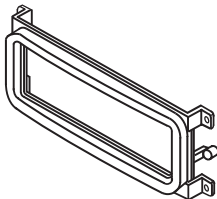

### APPLICATIONS

See page 2

### TABLE OF CONTENTS

Application Overview .....	2
Radio Housing (a).....	3-19
Radio Housing (b).....	20-23

### WIRING & ANTENNA CONNECTIONS (sold separately)

Wiring Harness: Please visit [metrafits.com](http://metrafits.com) for wiring harness options

Antenna Adapter: Please visit [metrafits.com](http://metrafits.com) for antenna adapter options

### TOOLS REQUIRED

- Phillips screwdriver • Cutting tool • Torx # 20
- Socket wrench • Panel removal tool

**Attention!** Let the vehicle sit with the key out of the ignition for a few minutes before removing the factory radio. When testing the aftermarket equipment, ensure that all factory equipment is connected before cycling the key to ignition.

# APPLICATION OVERVIEW

## Radio Housing (a): Pages 3-19

<b>Chrysler</b>		<b>Dodge</b>	
Cirrus	1995-2000	Aries	1981-1989
Concorde	1993-1997	Aspen	1976-1980
Cordoba	1975-1978	Avenger	1995-2000
Cordoba	1979-1983	Caravan	1984-1990
E-Class	1983-1984	Caravan	1991-1995
Fifth Avenue	1990-1994	Caravan	1996-2000
Imperial	1982-1983	Charger	1974-1978
Imperial	1990-1994	Charger	1983-1987
Laser	1984-1986	Dakota	1987-1996
LeBaron	1976-1981	Dakota	1997-2000
LeBaron	1982-1985	Daytona	1984-1989
LeBaron	1986-1994	Daytona	1990-1993
LeBaron GTS	1985-1994	Diplomat	1976-1989
LHS	1993-1997	Durango	1997-2000
Newport	1980-1981	Dynasty	1988-1993
New Yorker	1980-1981	Intrepid	1993-1997
New Yorker	1983-1987	Lancer	1985-1989
New Yorker	1988-1996	Magnum XE	1978-1979
Sebring	1995-2000	Mirada	1980-1983
Sebring (conv)	1996-2000	Neon	1994-1999
Town & Country		Omni	1978-1982
	1990-1995	Pickup	1974-1980
Town & Country		Pickup	1981-1993
	1996-2000	Ram	1994-2001

<b>Dodge (Cont)</b>	
Ramcharger	1974-1980
Ramcharger	1981-1993
Rampage	1978-1982
Shadow	1987-1994
Spirit	1989-1995
SI Regis	1979-1981
Stratus	1995-2000
Van	1978-2003
024	1978-1982
400	1982-1983
600	1983-1987
<b>Eagle</b>	
Vision	1993-1997
<b>Ford</b>	
Aerostar	1985-1991
Bronco II	1985-1988
Crown Victoria	1979-1990
LTD	1979-1990
Ranger (mini)	1985-1988
Thunderbird	1985-1988

<b>Jeep</b>	
Cherokee	1997-2001
Grand Cherokee	1993-1995
Grand Cherokee	1996-1998
Wrangler	1997-2002
<b>Lincoln</b>	
Continental	1985-1987
Mark VII	1984-1989
<b>Mercury</b>	
Cougar	1985-1988
Grand Marquis	1979-1990
Marquis	1979-1990
<b>Plymouth</b>	
Acclaim	1989-1995
Breeze	1996-2000
Caravelle	1985-1987
Fury	1975-1978
Gran Fury	1975-1985
Horizon	1978-1982
Neon	1994-1999
Reliant	1981-1989

<b>Plymouth (Cont)</b>	
Scamp	1983-1984
Sundance	1987-1994
TC3	1978-1982
Trailduster	1974-1980
Trailduster	1981
Turismo	1983-1987
Van	1978-2003
Volare	1976-1980
Voyager	1984-1990
Voyager	1991-1995
Voyager	1996-2000

## Radio Housing (b): Pages 20-23

<b>Chrysler</b>	
300M	1999-2004
Concorde	1998-2004
LHS	1999-2001
PT Cruiser	2001-2005
Sebring	2001-2006
Town & Country	2001-2007
<b>Dodge</b>	
Caravan	2001-2007
Dakota	2001-2004
Durango	2001-2003
Intrepid	1998-2004
Neon	2000-2006
Ram	2002-2005
Stratus	2001-2006
Viper	2003-2010
<b>Jeep</b>	
Grand Cherokee	1999-2004
Liberty	2002-2007
Wrangler	2003-2006
<b>Plymouth</b>	
Neon	2000-2001

# RADIO HOUSING (A) INSTRUCTIONS

## KIT FEATURES

- DIN radio provision

## KIT COMPONENTS

- A) Radio housing • B) Support spacers (Avenger/Sebring)

## WIRING & ANTENNA CONNECTIONS (sold separately)

Wiring Harness: Please visit [metrafits.com](http://metrafits.com) for wiring harness options

Antenna Adapter: Not required

## APPLICATIONS

<b>Chrysler</b>	Newport	1980-1981	Caravan	1996-2000	Omni	1978-1982	<b>Eagle</b>	Lincoln	Neon	1994-1999		
Cirrus	1995-2000	New Yorker	1980-1981	Charger	1974-1978	Pickup	Vision	1993-1997	Continental	1985-1987	Reliant	1981-1989
Concorde	1993-1997	New Yorker	1983-1987	Charger	1983-1987	Pickup	<b>Ford</b>	Mark VII	1984-1989	Scamp	1983-1984	
Cordoba	1975-1978	New Yorker	1988-1996	Dakota	1987-1996	Ram	Aerostar	1985-1991	<b>Mercury</b>	Sundance	1987-1994	
Cordoba	1979-1983	Sebring	1995-2000	Dakota	1997-2000	Ramcharger	Bronco II	1985-1988	Cougar	1985-1988	TC3	1978-1982
E-Class	1983-1984	Sebring (conv)	1996-2000	Daytona	1984-1989	Ramcharger	Crown Victoria	1979-1990	Grand Marquis	1979-1990	Trailduster	1974-1980
Fifth Avenue	1990-1994	Town & Country	1990-1995	Daytona	1990-1993	Rampage	LTD	1979-1990	Marquis	1979-1990	Trailduster	1981
Imperial	1982-1983	Town & Country	1996-2000	Diplomat	1976-1989	Shadow	Ranger (mini)	1985-1988	<b>Plymouth</b>	Turismo	1983-1987	
Imperial	1990-1994	<b>Dodge</b>	Durango	Dynasty	1997-2000	Spirit	Thunderbird	1985-1988	Acclaim	1989-1995	Van	1978-2003
Laser	1984-1986	Aries	1981-1989	Dynasty	1988-1993	Spirit			Breeze	1989-1995	Volare	1976-1980
LeBaron	1976-1981	Aspen	1976-1980	Intrepid	1993-1997	Stratus	1995-2000	<b>Jeep</b>	Caravelle	1996-2000	Voyager	1984-1990
LeBaron	1982-1985	Avenger	1995-2000	Lancer	1985-1989	Van	1978-2003	Cherokee	Fury	1985-1987	Voyager	1991-1995
LeBaron	1986-1994	Caravan	1984-1990	Magnum XE	1978-1979	024	1978-1982	Grand Cherokee	Gran Fury	1975-1978	Voyager	1996-2000
LeBaron GTS	1985-1994	Caravan	1991-1995	Mirada	1980-1983	400	1982-1983	Grand Cherokee	Horizon	1975-1985		
LHS	1993-1997	Caravan	1991-1995	Neon	1994-1999	600	1983-1987	Wrangler		1978-1982		

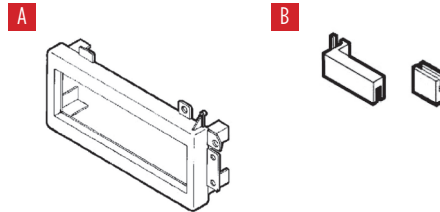

## TABLE OF CONTENTS

Dash Disassembly .....	4-17
Kit Assembly .....	17
Final Kit Assembly .....	18-19

## TOOLS REQUIRED

- Phillips screwdriver • Cutting tool
- Socket wrench

## DASH DISASSEMBLY

**Chrysler Cirrus 1995-2000**  
**Dodge Stratus 1995-2000**  
**Plymouth Breeze 1996-2000**

1. Using a flat-blade screwdriver, pry out on the edges of the radio trim bezel. Unclip the bezel and remove. (Figure A)
2. Remove (2) 3/8" hex-head screws securing the factory radio and disconnect the wiring. (Figure A)
3. Cut and remove all mounting tabs on the radio housing EXCEPT the shaded tabs. (Figure B)

*Continue to Kit Assembly*

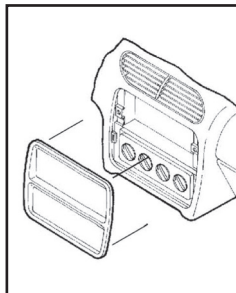

(Figure A)

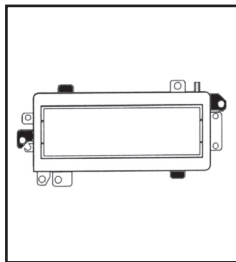

(Figure B)

**Chrysler Concorde/LHS 1993-1997**  
**Dodge Intrepid 1993-1997**  
**Eagle Vision 1993-1997**

1. Unclip the radio trim bezel and remove. (Figure A)
2. Remove (2) 3/8" hex-head screws securing the factory radio and disconnect the wiring. (Figure A)
3. Cut and remove all mounting tabs on the radio housing EXCEPT the shaded tabs. (Figure B)

*Continue to Kit Assembly*

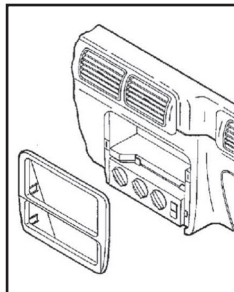

(Figure A)

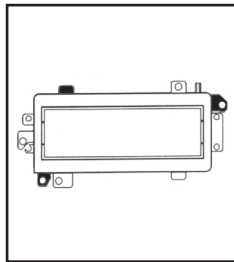

(Figure B)

**Chrysler Cordoba 1975-1978**  
**Dodge Charger 1974-1978 / Magnum XE 1978-1979**  
**Plymouth Fury 1975-1978**

1. Remove (4) Phillips screws from the bottom edge of the radio trim bezel. (Figure A)
2. Remove (2) Phillips screws above the radio opening. (Figure A)
3. Unscrew the retainer ring securing the remote mirror control and remove the bezel. (Figure A)
4. Remove (2) 3/8" hex-head screws securing the factory radio and disconnect the wiring. (Figure A)
5. Cut and remove all mounting tabs on the radio housing EXCEPT the shaded tabs. (Figure B)

*Continue to Kit Assembly*

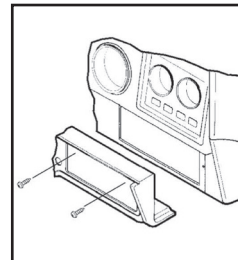

(Figure A)

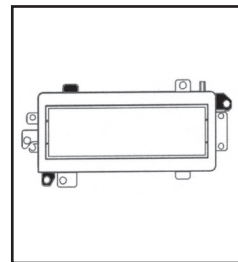

(Figure B)

## DASH DISASSEMBLY

**Chrysler Cordoba 1979-1985 / Imperial 1982-1983 / Newport/New Yorker 1980-1981  
Dodge Mirada 1980-1983/St. Regis 1979-1981**

1. Remove (2) Phillips screws from the bottom edge of the radio trim bezel. (Figure A)
2. Remove (2) Phillips screws above the radio opening.
3. Unscrew the retainer ring securing the remote mirror control and remove the bezel.
4. Remove (2) 3/8" hex-head screws securing the factory radio and disconnect the wiring.
5. Cut and remove all mounting tabs on the radio housing EXCEPT the shaded tabs. (Figure B)

*Continue to Kit Assembly*

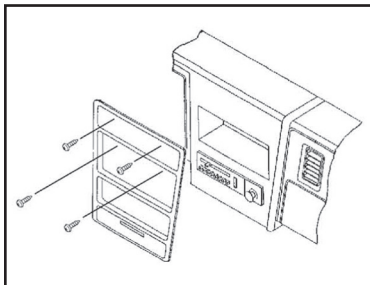

(Figure A)

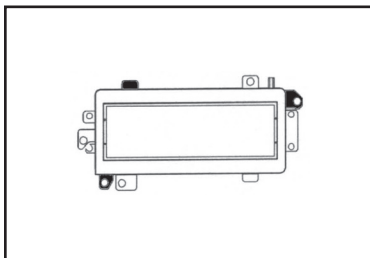

(Figure B)

**Chrysler E-Class 1983-1984 / LeBaron 1982-1985 / New Yorker 1983-1987  
Dodge Aries 1981-1989 / 400 1982-1983 / 600 1983-1987  
Plymouth Caravelle 1985-1987 / Reliant 1981-1989**

1. Remove (3) Phillips screws from the top edge of the dash trim bezel.
2. Remove (3) Phillips screws from the bottom edge of the dash trim bezel.
3. Unclip the bezel and disconnect the wiring. (Figure A)
4. Remove (2) 3/8" hex-head bolts securing the factory radio and disconnect the wiring.
5. Cut and remove all mounting tabs on the radio housing EXCEPT the shaded tabs. (Figure B)

*Continue to Kit Assembly*

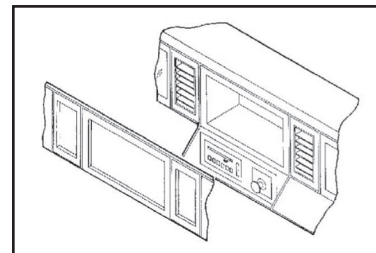

(Figure A)

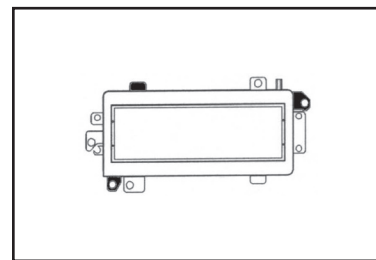

(Figure B)

## DASH DISASSEMBLY

**Chrysler Fifth Avenue 1990-1994 / Imperial 1990-1994 /  
Chrysler New Yorker 1988-1996  
Dodge Dynasty 1988-1993**

1. Remove (2) Phillips screws above the radio opening. (Figure A)
2. Remove (2) Phillips screws above the climate controls. (Figure A)
3. Unclip the dash trim bezel and remove.
4. Remove (2) 3/8" hex-head screws securing the factory radio and disconnect the wiring. (Figure A)
5. Cut and remove all mounting tabs on the radio housing EXCEPT the shaded tabs. (Figure B)

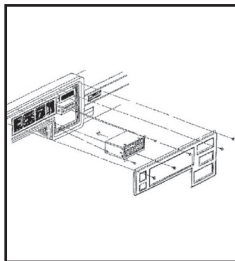

(Figure A)

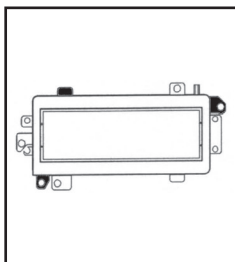

(Figure B)

*Continue to Kit Assembly*

**Chrysler Laser 1984-1986  
Dodge Daytona 1984-1989**

1. Remove (2) Phillips screws from the base of the dash trim bezel.
2. Pullout on the lower edge of the bezel and remove. (Figure A)
3. Remove (2) 3/8" hex-head screws securing the factory radio and disconnect the wiring.
4. Cut and remove all mounting tabs on the radio housing EXCEPT the shaded tabs. (Figure B)

*Continue to Kit Assembly*

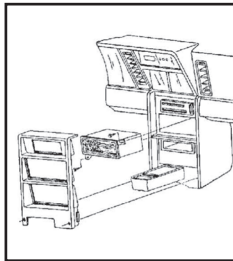

(Figure A)

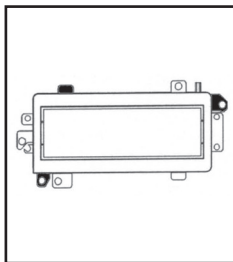

(Figure B)

**Chrysler LeBaron 1986-1994**

1. Remove (1) Phillips screw from the lower corner of the dash trim bezel.
2. Unclip the bezel and remove.
3. Remove (2) Phillips screws from the right console panel and remove the panel. (Figure A)
4. Remove (2) hex-head screws securing the factory radio and disconnect the wiring.
5. Cut and remove all mounting tabs on the radio housing EXCEPT the shaded tabs. (Figure B)

*Continue to Kit Assembly*

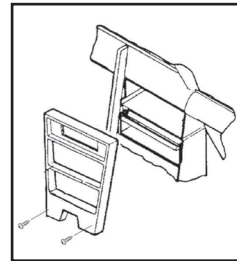

(Figure A)

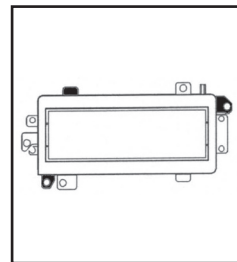

(Figure B)

# DASH DISASSEMBLY

## Chrysler LeBaron GTS 1985-1994, Dodge Lancer 1985-1989

1. Remove (5) torx-head screws from the top of the dash trim bezel.
2. Remove (2) torx-head screws below the radio opening.
3. Remove (1) torx-head screw from the upper-left corner of the radio opening.
4. Remove (4) torx-head screws from the lower-left area of the dash trim bezel. (Figure A)
5. Unclip the bezel and remove. Remove (2) 3/8" hex-head bolts securing the factory radio and disconnect the wiring.
6. Cut and remove all mounting tabs on the radio housing EXCEPT the shaded tabs. (Figure B)

*Continue to Kit Assembly*

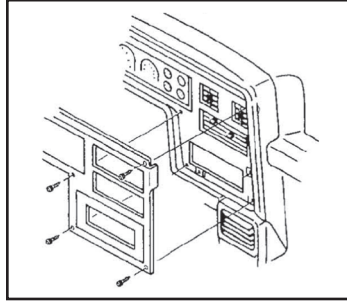

(Figure A)

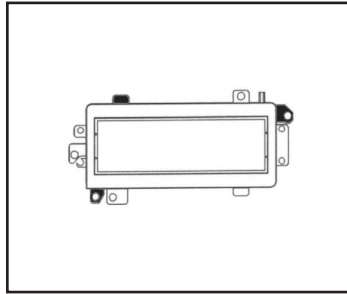

(Figure B)

## Chrysler LeBaron 1976-1981 Dodge Diplomat 1976-1989 / Aspen 1976-1980, Plymouth Gran Fury 1975-1985 / Volare 1976-1980

1. Remove (4) Phillips screws from the top of the dash trim bezel and then remove (4) from the bottom of the dash trim bezel. (Figure A)
2. Remove (2) 3/8" hex-head screws securing the factory radio and disconnect the wiring.
3. Cut and remove all mounting tabs on the radio housing EXCEPT the shaded tabs. (Figure B)

*Continue to Kit Assembly*

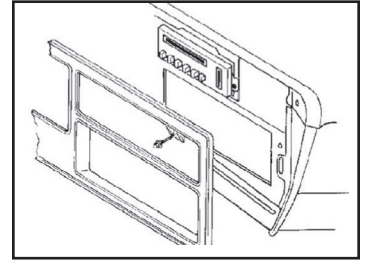

(Figure A)

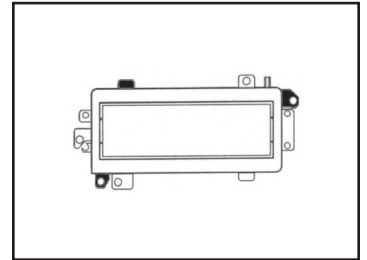

(Figure B)

# DASH DISASSEMBLY

## Chrysler Sebring (convertible) 1996-2000

1. Unclip the radio trim bezel and remove. (Figure A)
2. Remove (2) 3/8" hex-head screws securing the factory radio and disconnect the wiring.
3. Cut and remove all mounting tabs on the radio housing EXCEPT the shaded tabs. (Figure B)

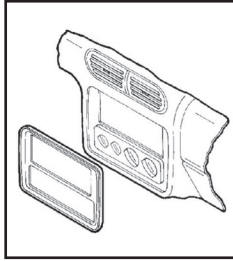

(Figure A)

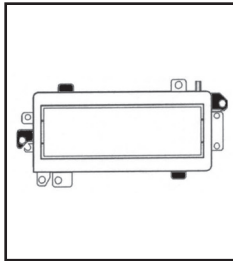

(Figure B)

Continue to Kit Assembly

## Dodge Sebring 1995-2000 / Avenger 1995-2000

1. Unclip the radio trim bezel and remove. (Figure A)
2. Remove (2) #10 Phillips screws securing the factory radio and disconnect the wiring.
3. Cut and remove all mounting tabs on the radio housing EXCEPT the shaded tabs. (Figure B)

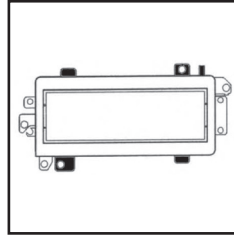

(Figure B)

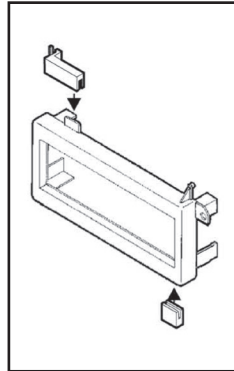

(Figure C)

Continue to Kit Assembly

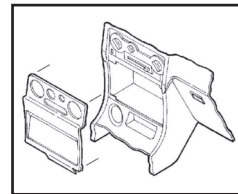

(Figure A)

## Dodge Caravan 1991-1995 Plymouth Voyager 1991-1995

1. Remove the cigarette lighter.
2. Using a panel removal tool, pry out on the dash trim bezel and remove. (Figure A)
3. Remove (2) 3/8" bolts securing the factory radio and disconnect the wiring.
4. Cut and remove all mounting tabs on the radio housing EXCEPT the shaded tabs. (Figure B)

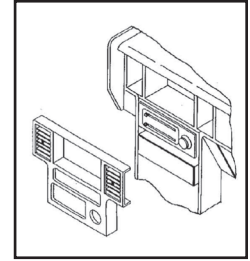

(Figure A)

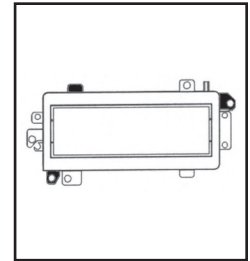

(Figure B)

Continue to Kit Assembly



## DASH DISASSEMBLY

**Chrysler Town & Country 1990-1995**  
**Dodge Caravan 1984-1990**  
**Plymouth Voyager 1984-1990**

1. Reach behind the ashtray and release the rear tab on the ashtray housing.
2. Remove (2) screws from the bottom edge of the dash trim bezel. Remove (3) screws from the top edge of the dash trim bezel. (Figure A)
3. Unsnap the left edge of the bezel and remove.
4. Remove (2) 3/8" hex-head screws securing the factory radio and disconnect the wiring.
5. Cut and remove all mounting tabs on the radio housing EXCEPT the shaded tabs. (Figure B)

*Continue to Kit Assembly*

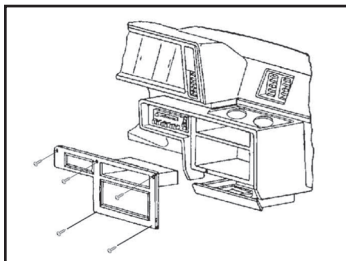

(Figure A)

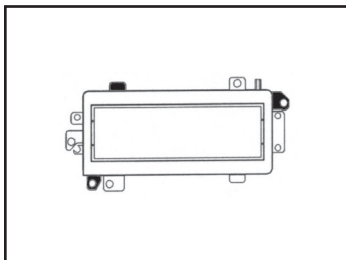

(Figure B)

**Chrysler Town & Country 1996-2000**  
**Dodge Caravan 1996-2000**  
**Plymouth Voyager 1996-2000**

1. Pull the ashtray forward. Unsnap the plastic trim piece located below the radio trim bezel and remove (2) Phillips screws exposed. (Figure A)
2. Remove (2) Phillips screws above the radio opening.
3. Unclip the dash trim bezel, disconnect the climate control wiring and remove the bezel.
4. Remove (2) 3/8" hex-head screws securing the factory radio and disconnect the wiring.
5. Cut and remove all mounting tabs on the radio housing EXCEPT the shaded tabs. (Figure B)

*Continue to Kit Assembly*

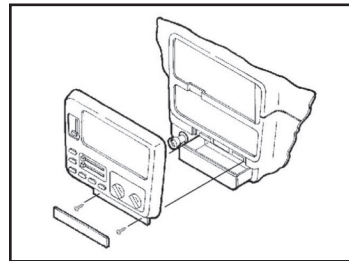

(Figure A)

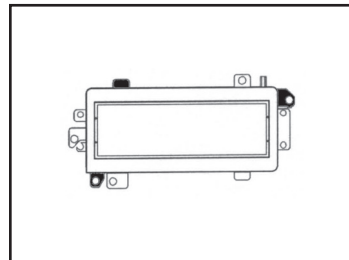

(Figure B)

# DASH DISASSEMBLY

## Dodge Charger 1983-1987 Plymouth Turismo 1983-1987

1. Unclip the radio trim bezel and remove.
2. Remove (2) 3/8" hex-head screws securing the factory radio and disconnect the wiring.
3. Cut and remove all mounting tabs on the radio housing EXCEPT the shaded tabs. (Figure B)

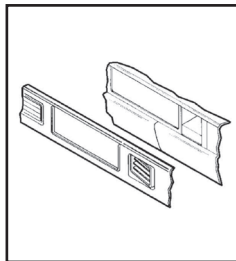

(Figure A)

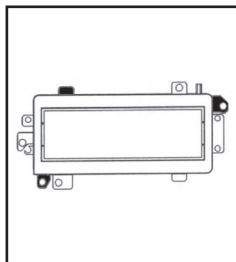

(Figure B)

*Continue to Kit Assembly*

## Dodge Dakota 1987-1996

1. Remove (8) torx-head screws from the dash trim bezel.
2. Remove (2) Phillips screws from the lower steering column trim and remove.
3. Remove (1) Phillips screw from each side of the steering column.
4. Unclip the dash trim bezel and remove. (Figure A)
5. Remove (2) Phillips screws securing the factory radio and disconnect the wiring.
6. Cut and remove all mounting tabs on the radio housing EXCEPT the shaded tabs. (Figure B)

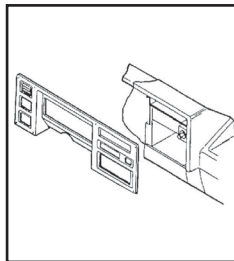

(Figure A)

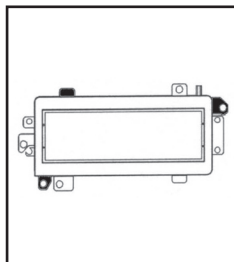

(Figure B)

*Continue to Kit Assembly*

## Dodge Dakota 1997-2000

1. Unclip the entire dash trim bezel. (Figure A)
2. Remove (2) 3/8" hex-head screws securing the factory radio and disconnect the wiring.
3. Cut and remove all mounting tabs on the radio housing EXCEPT the shaded tabs. (Figure B)

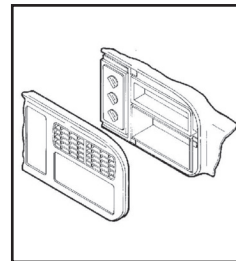

(Figure A)

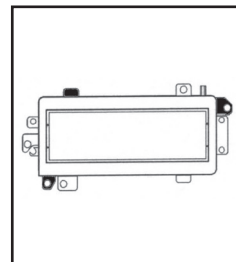

(Figure B)

*Continue to Kit Assembly*

# DASH DISASSEMBLY

## Dodge Daytona 1990-1993

1. Pull out on the dash trim bezel and remove. (Figure A)
2. Remove (2) screws from each side of the lower console (this will allow easier radio removal).
3. Remove (2) screws securing the factory radio and disconnect the wiring.
4. Cut and remove all mounting tabs on the radio housing EXCEPT the shaded tabs. (Figure B)

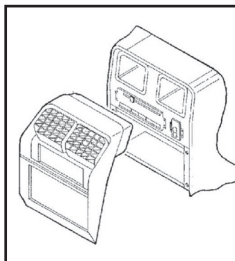

(Figure A)

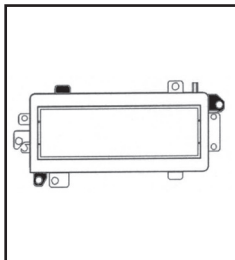

(Figure B)

*Continue to Kit Assembly*

## Dodge Durango 1997-2000

1. Unclip the entire dash trim bezel. (Figure A)
2. Remove (2) 3/8" hex-head screws securing the factory radio and disconnect the wiring.
3. Cut and remove all mounting tabs on the radio housing EXCEPT the shaded tabs. (Figure B)

*Continue to Kit Assembly*

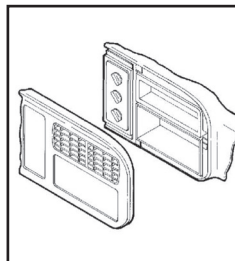

(Figure A)

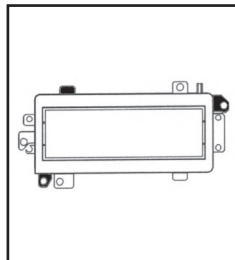

(Figure B)

## Dodge Neon 1994-1999 Plymouth Neon 1994-1999

1. Remove the ashtray. Unclip the radio trim bezel and remove. (Figure A)
2. Remove (2) 3/8" hex-head screws securing the factory radio and disconnect the wiring.
3. Cut and remove all mounting tabs on the radio housing EXCEPT the shaded tabs. (Figure B)

*Continue to Kit Assembly*

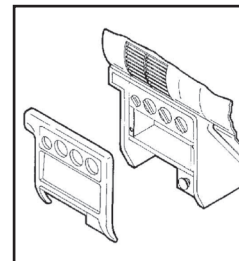

(Figure A)

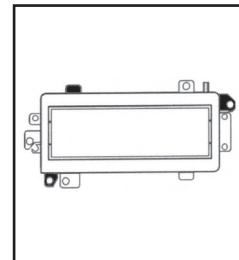

(Figure B)

## DASH DISASSEMBLY

### Dodge Omni/024/Rampage 1978-1982 Plymouth Horizon/TC3 1978-1982/Scamp 1983-1984

1. Remove (7) Phillips screws from the dash trim bezel and remove the bezel. (Figure A)
2. Remove (2) 3/8" hex-head screws securing the factory radio and disconnect the wiring. (Figure B)
3. Cut and remove all mounting tabs on the radio housing EXCEPT the shaded tabs. (Figure B)

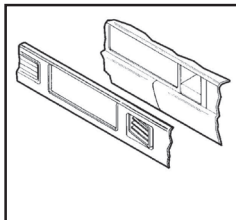

(Figure A)

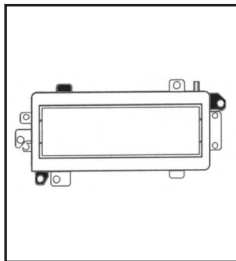

(Figure B)

*Continue to Kit Assembly*

### Dodge Pickup/Ramcharger 1974-1980 Plymouth Trailduster 1974-1980

1. Remove (4) Phillips screws from the top edge of the dash trim bezel. (Figure A)
2. Remove (7) Phillips screws from the face of the dash trim bezel.
3. Remove (3) Phillips screws under the dash trim bezel.
4. Unclip the bezel and remove. Remove (2) 3/8" hex-head screws securing the factory radio and disconnect the wiring.
5. Cut and remove all mounting tabs on the radio housing EXCEPT the shaded tabs. (Figure B)

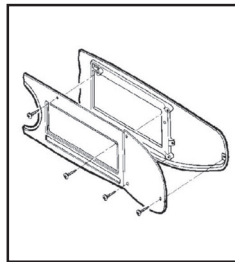

(Figure A)

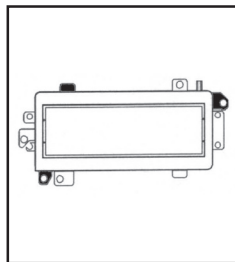

(Figure B)

*Continue to Kit Assembly*

### Dodge Pickup/Ramcharger 1981-1993 Plymouth Trailduster 1981

1. Remove (5) Phillips screws from the edge of the dash trim bezel.
2. Remove (1) Phillips screw above the radio opening.
3. Pry out on the bottom edge of the bezel and remove. (Figure A)
4. Remove (2) 3/8" hex-head screws securing the factory radio and disconnect the wiring.
5. Cut and remove all mounting tabs on the radio housing EXCEPT the shaded tabs. (Figure B)

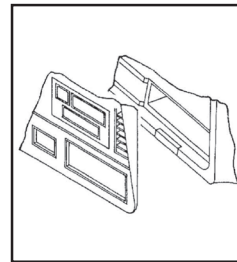

(Figure A)

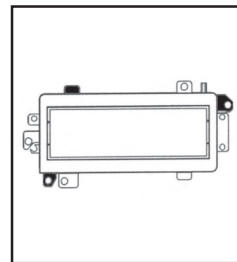

(Figure B)

*Continue to Kit Assembly*

# DASH DISASSEMBLY

## Dodge Ram 1994–2001

1. Remove the ashtray. Remove (2) Phillips screws exposed in the ashtray cavity and remove the ashtray bracket. (Figure A)
2. Remove the cupholder. Remove (2) Phillips screws exposed in the cup holder cavity and remove the cupholder bracket. (Figure A)
3. Unclip the dash trim bezel, pull the bezel over the steering column and remove.
4. Remove (2) 3/8" hex-head screws securing the factory radio and disconnect the wiring.

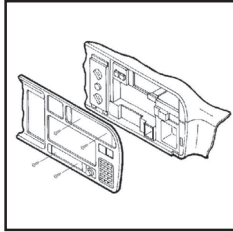

(Figure A)

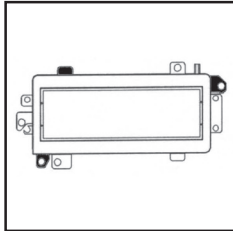

(Figure B)

5. Cut and remove all mounting tabs on the radio housing EXCEPT the shaded tabs. (Figure B)

*Continue to Kit Assembly*

## Dodge Shadow 1987–1994 Plymouth Sundance 1987–1994

1. Remove the ashtray. Unclip the dash trim bezel and remove. (Figure A)
2. Remove (1) Phillips screw from the console side trim and remove.
3. Remove (2) 3/8" hex-head bolts securing the factory radio and disconnect the wiring.
4. Cut and remove all mounting tabs on the radio housing EXCEPT the shaded tabs. (Figure B)

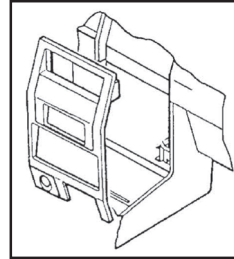

(Figure A)

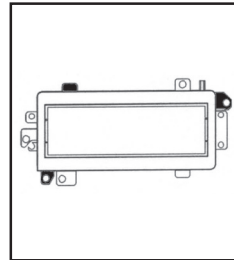

(Figure B)

*Continue to Kit Assembly*

## Dodge Spirit 1989–1995 Plymouth Acclaim 1989–1995

1. Unclip the dash trim bezel and remove. Remove the screws securing the side console trim pieces. (Figure A)
2. Pull the right trim piece out and remove (1) hex-head bolt exposed.
3. Remove (1) hex-head bolt securing the bottom-left corner of the factory radio and disconnect the wiring.
4. Cut and remove all mounting tabs on the radio housing EXCEPT the shaded tabs. (Figure B)

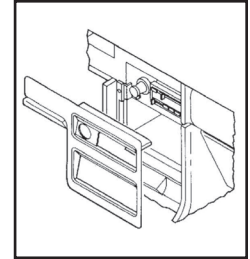

(Figure A)

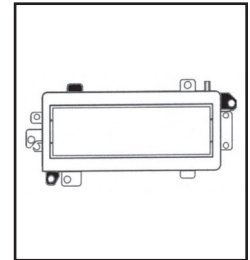

(Figure B)

*Continue to Kit Assembly*

# DASH DISASSEMBLY

## Dodge Van 1978-2003 Plymouth Van 1978-2003

1. Open the glove box and remove (2) Phillips screws exposed.
2. Remove (5) Phillips screws from the bottom of the dash trim bezel.
3. Unclip the top edge of the bezel and remove.
4. Remove (2) 3/8" hex-head screws securing the factory radio and disconnect the wiring.
5. Cut and remove all mounting tabs on the radio housing EXCEPT the shaded tabs.

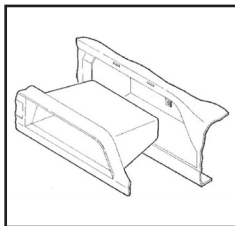

(Figure A)

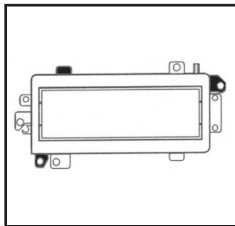

(Figure B)

## For Dodge Van 1998-2003

1. Unclip and remove entire panel surrounding radio and instrument cluster.
2. Remove (2) 3/8" hex-head screws securing the factory radio and disconnect the wiring.

*Continue to Kit Assembly*

## Ford Aerostar 1985-1991

1. Remove (2) Phillips screws from the base of the dash panel. (Figure A)
2. Pry down on the (2) tabs located at the top of the radio trim bezel and remove the bezel. (Figure A)
3. Remove (4) screws securing the factory radio and disconnect the wiring.
4. Cut and remove all mounting tabs on the radio housing EXCEPT the shaded tabs. (Figure B)

*Continue to Kit Assembly*

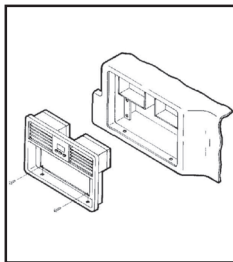

(Figure A)

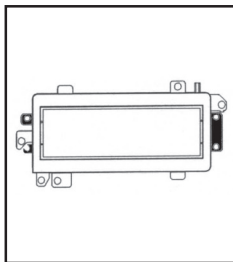

(Figure B)

## Ford Bronco II/Ranger (mini) 1985-1988

1. Remove (4) Phillips screws from the top edge of the dash trim bezel. (Figure A)
2. Remove the light switch knob, cigarette lighter and ashtray.
3. Unsnap the molding under the dash trim bezel and remove (4) screws exposed. (Figure A)
4. Remove (4) screws securing the factory radio and disconnect the wiring.
5. Cut and remove all mounting tabs on the radio housing EXCEPT the shaded tabs. (Figure B)

*Continue to Kit Assembly*

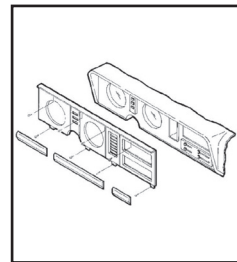

(Figure A)

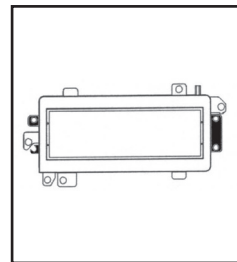

(Figure B)

## DASH DISASSEMBLY

### Ford Crown Victoria/LTD 1979-1990, Mercury Grand Marquis/Marquis 1979-1990

1. Open the ashtray and remove (2) Phillips screws exposed. (Figure A)
2. Remove the dash trim bezel.
3. Remove (4) screws securing the factory radio and disconnect the wiring.
4. Cut and remove all mounting tabs on the radio housing EXCEPT the shaded tabs. (Figure B)

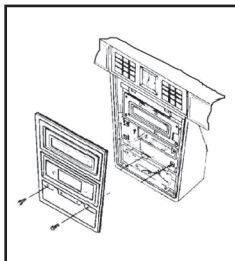

(Figure A)

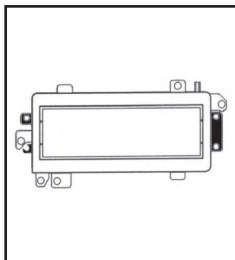

(Figure B)

*Continue to Kit Assembly*

### Ford Thunderbird 1985-1988 Mercury Cougar 1985-1988

1. Remove (2) screws from the top of the dash trim bezel. (Figure A)
2. Open the ashtray and remove (2) screws exposed in the ashtray cavity. (Figure A)
3. Remove the dash trim bezel. Remove (4) screws securing the factory radio and disconnect the wiring.
4. Cut and remove all mounting tabs on the radio housing EXCEPT the shaded tabs. (Figure B)

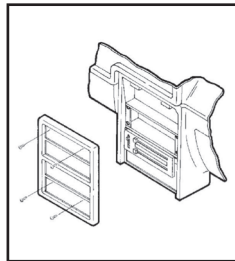

(Figure A)

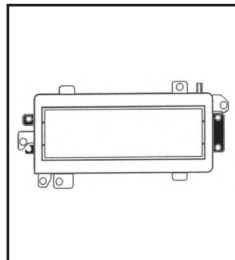

(Figure B)

*Continue to Kit Assembly*

### Jeep Cherokee 1997-2001

1. Unclip the dash trim bezel. (Figure A)
2. Remove (2) #10 hexhead screws securing the factory radio and disconnect the wiring.
3. Cut and remove all mounting tabs on the radio housing EXCEPT the shaded tabs. (Figure B)

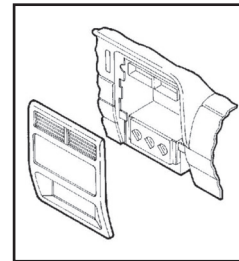

(Figure A)

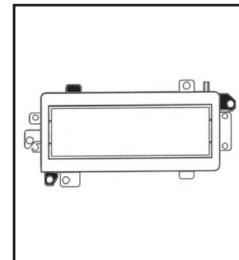

(Figure B)

*Continue to Kit Assembly*

## DASH DISASSEMBLY

### Jeep Grand Cherokee 1993-1995

1. Remove (2) Phillips screws from the bottom of the dash trim bezel. (Figure A)
2. Remove (2) Phillips screws above the radio opening. (Figure A)
3. Remove (2) Phillips screws to the left of the steering column. (Figure A)
4. Remove (1) Phillips screw to the right of the steering column. Unclip the dash trim bezel and disconnect the wiring.
5. Cut and remove all mounting tabs on the radio housing EXCEPT the shaded tabs. (Figure B)

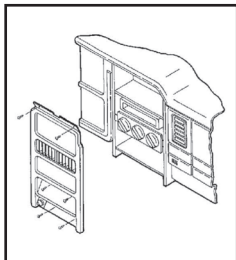

(Figure A)

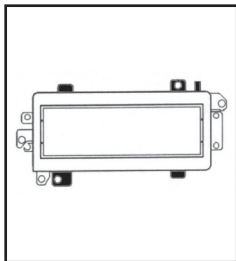

(Figure B)

Continue to Kit Assembly

### Jeep Grand Cherokee 1996-1998

1. Unsnap the climate control/wiper control trim panel and remove.
2. Remove (5) Phillips screws from the top of the radio/instrument cluster trim bezel.
3. Remove (4) Phillips screws from the bottom of the radio/instrument cluster trim bezel.
4. Pry out on the bottom edge of the bezel and remove. (Figure A)
5. Remove (2) 3/8" hex-head screws securing the factory radio and disconnect the wiring.
6. Cut and remove all mounting tabs on the radio housing EXCEPT the shaded tabs. (Figure B)

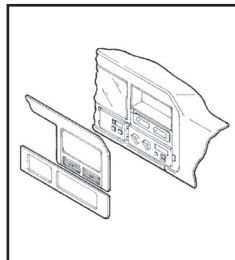

(Figure A)

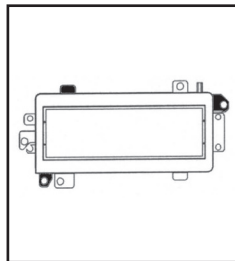

(Figure B)

Continue to Kit Assembly

### Jeep Wrangler 1997-2002

1. Remove the ashtray and (1) Phillips screw exposed in the ashtray cavity. (Figure A)
2. Pry out on the top cover of the instrument panel and remove (2) Phillips screws exposed.
3. Pry out on the bottom edge of the dash trim bezel and remove.
4. Remove (2) 3/8" hex-head screws securing the factory radio and disconnect the wiring.
5. Cut and remove all mounting tabs on the radio housing EXCEPT the shaded tabs. (Figure B)

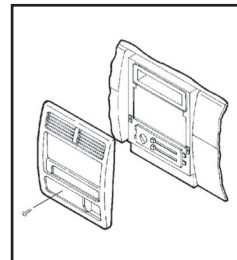

(Figure A)

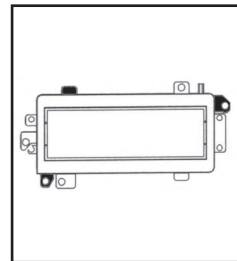

(Figure B)

Continue to Kit Assembly



## DASH DISASSEMBLY

### Lincoln Continental 1985-1987

1. Remove (2) #8 Phillips screws below the radio opening. (Figure A)
2. Open the ashtray and remove (2) #8 Phillips screws (it is NOT necessary to remove the center screw). (Figure A)
3. Unclip the dash trim bezel and remove.
4. Remove (4) hex-head screws securing the factory radio and disconnect the wiring.
5. Cut and remove all mounting tabs on the radio housing EXCEPT the shaded tabs. (Figure B)

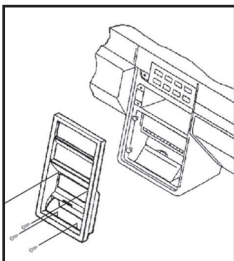

(Figure A)

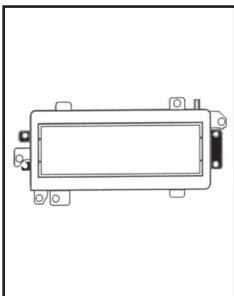

(Figure B)

*Continue to Kit Assembly*

### Lincoln Mark VII 1984-1989

1. Pry out on the dash trim bezel and remove. (Figure A)
2. Remove (4) 5mm hex-head sheet metal screws securing the factory radio and disconnect the wiring.
3. Cut and remove all mounting tabs on the radio housing EXCEPT the shaded tabs. (Figure B)

*Continue to Kit Assembly*

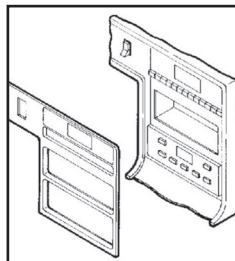

(Figure A)

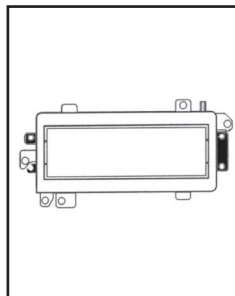

(Figure B)

## KIT ASSEMBLY

### DIN radio provision

1. Remove the metal DIN sleeve from the aftermarket radio.
2. Slide the sleeve into the **radio housing** and secure by bending the metal locking tabs down.
3. Slide the radio back into the sleeve until it clicks in. (Figure A)

*Continue to Final Kit Assembly*

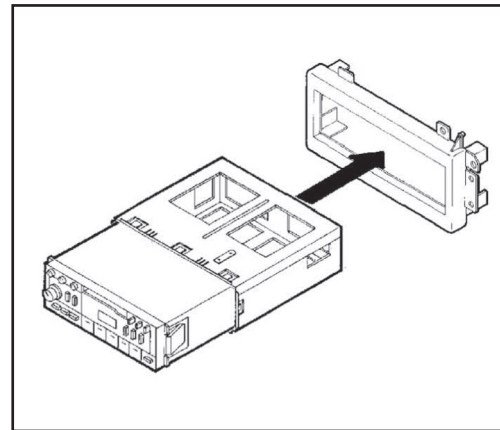

(Figure A)

## FINAL KIT ASSEMBLY

1. Locate the factory wiring harness and antenna adapter in the dash. Metra recommends using the proper mating adapter from Metra or AXCESS. Test the radio for proper operation.

### Ford/Lincoln/Mercury

2. Mount the radio/kit assembly to the sub-dash with (4) screws previously removed. (Figure A)
3. Reassemble dash in reverse order of disassembly.

### Chrysler/Dodge/Plymouth/Eagle/Jeep

(excluding Grand Cherokee 1993-1995, Cirrus, Stratus, Breeze, Sebring, Avenger)

2. Mount the radio/kit assembly to the sub-dash with (2) 3/8" hex-head screws previously removed. (Figure B)
3. Reassemble dash in reverse order of disassembly.

### Jeep Grand Cherokee 1993-1995

2. Mount the radio/kit assembly to the sub-dash with (2) screws previously removed. (Figure C)
3. Reassemble dash in reverse order of disassembly.

*Continued on the next page*

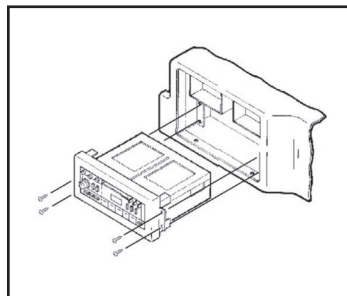

(Figure A)

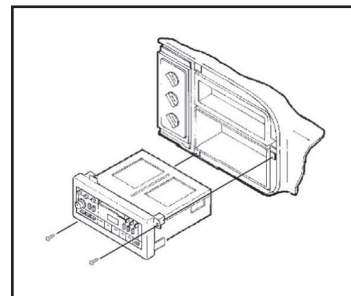

(Figure B)

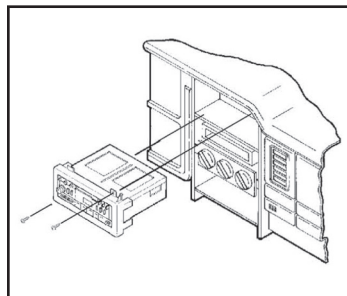

(Figure C)

## FINAL KIT ASSEMBLY *(CONT)*

### **Chrysler Cirrus, Dodge Stratus, Plymouth Breeze**

2. Mount the radio/kit assembly to the sub-dash with (2) screws previously removed. (Figure D)
3. Reassemble dash in reverse order of disassembly.

### **Chrysler Sebring, Dodge Avenger**

2. Remove the top-left screw from the metal dash housing.
3. Mount the radio/kit assembly to the sub-dash with (2) screws previously removed. (Figure E)
4. Replace the metal housing screw through the top Support Spacer. (Figure E)
5. Reassemble dash in reverse order of disassembly.

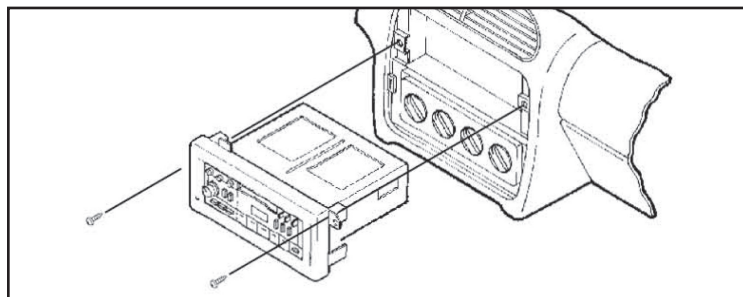

(Figure D)

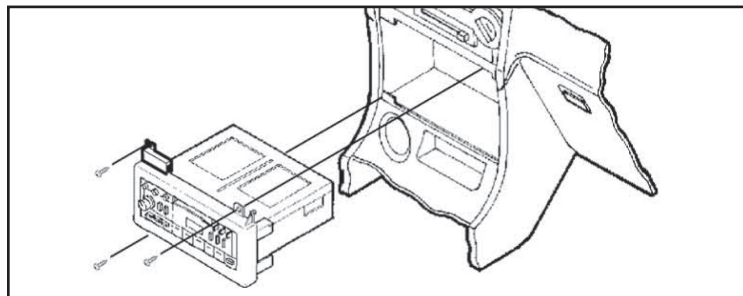

(Figure E)

# RADIO HOUSING (B) INSTRUCTIONS

## KIT FEATURES

- DIN radio provision

## KIT COMPONENTS

- A) Radio housing

## WIRING & ANTENNA CONNECTIONS (sold separately)

Wiring Harness: Please visit [metrafits.com](http://metrafits.com) for wiring harness options

Antenna Adapter: Please visit [metrafits.com](http://metrafits.com) for antenna adapter options

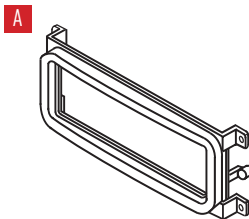

## TABLE OF CONTENTS

Dash Disassembly .....	21-23
Kit Assembly .....	24

## TOOLS REQUIRED

- Phillips Screwdriver
- Torx # 20
- Socket Wrench
- Panel removal tool

## APPLICATIONS

Chrysler		Dodge		Dodge (Cont)		Plymouth	
300M	1999-2004	Caravan	2001-2007	Stratus	2001-2006	Neon	2000-2001
Concorde	1998-2004	Dakota	2001-2004	Viper	2003-2010		
LHS	1999-2001	Durango	2001-2003	<b>Jeep</b>			
PT Cruiser	2001-2005	Intrepid	1998-2004	Grand Cherokee	1999-2004		
Sebring	2001-2006	Neon	2000-2006	Liberty	2002-2007		
Town & Country	2001-2007	Ram	2002-2005	Wrangler	2003-2006		

## DASH DISASSEMBLY

### Chrysler 300M 1999-2004/Concorde 1998-2004/ Chrysler LHS 1999-2001 Dodge Intrepid 1998-2004

1. Remove the ashtray by pressing down on the inner spring clip (Concorde only).
2. Unclip gear shifter trim panel and slide trim panel toward the rear of the vehicle.
3. Unclip dash trim panel and disconnect the wire to the trim panel.
4. Remove (4) Phillips head screws securing the radio. Disconnect and remove the radio.

*Continue to Kit Assembly*

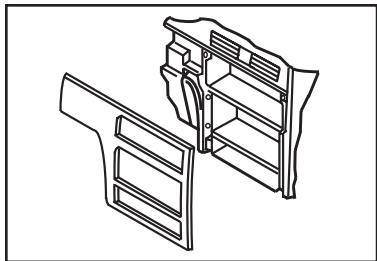

(Figure A)

### Chrysler PT Cruiser 2001-2005

1. Unclip power window control panel. Disconnect and remove panel.
2. Pull off climate control knobs.
3. Unclip and remove the dash trim panel.
4. Remove (4) Phillips head screws securing the radio. Disconnect and remove the radio.

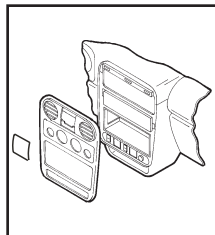

(Figure A)

*Continue to Kit Assembly*

### Chrysler Sebring 2001-2006 Dodge Stratus 2001-2006

1. Remove (2) Phillips head screws from under the climate controls (Coupe only).
2. Unclip and remove radio trim panel.
3. Remove (4) Phillips head screws securing the radio. Disconnect and remove the radio.

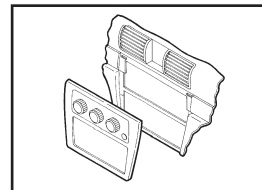

(Figure A)

*Continue to Kit Assembly*

### Chrysler Town & Country 2001-2007 Dodge Caravan 2001-2007

1. Open cup holder. Unclip and remove trim above cup holder.
2. Remove (2) Phillips head screws from above cup holder.
3. Unclip and remove the dash trim panel.
4. Remove (4) Phillips head screws securing the radio. Disconnect and remove the radio.

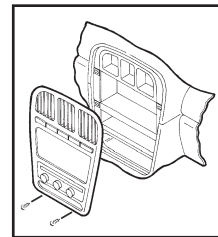

(Figure A)

*Continue to Kit Assembly*

## DASH DISASSEMBLY

### Dodge Neon 2000-2006 Plymouth Neon 2000-2001

1. Pull off climate control knobs.
2. Unclip and remove A/C and heater vents.
3. Remove (1) Phillips head screw from each vent cavity.
4. Unclip and remove dash trim panel.
5. Remove (4) Phillips head screws securing the radio. Disconnect and remove the radio.

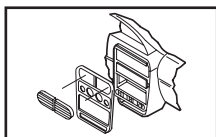

(Figure A)

*Continue to Kit Assembly*

### Dodge Ram 2002-2005

1. Unclip the top edge of the trim panel below the steering column (it is not necessary to completely remove this panel).
2. Remove (1) Phillips head screw from below right A/C heater vent.
4. Remove (4) Phillips head screws securing the radio. Disconnect and remove the radio.

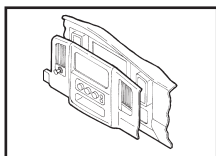

(Figure A)

*Continue to Kit Assembly*

### Dodge Viper 2003-2010

1. Using a small flat blade screw driver, pry up on center console trim panel (take care not to scratch the trim panel). (Figure A)
2. Loosen the shifter lock nut below center console trim panel (Figure A) and unscrew the shifter knob. (Figure B)
3. Unplug electrical connectors and remove center console trim panel. (Figure C)
4. Remove (6) Allen screws from radio/climate control trim panel and (1) Phillips screw at the bottom of the panel.
5. Unplug electrical connectors and remove the panel. (Figure D)
6. Remove (4) screws securing the radio. Disconnect and remove the radio.

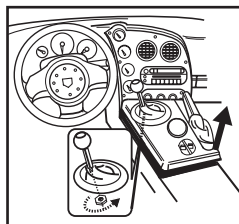

(Figure A)

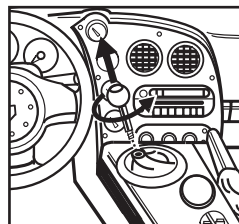

(Figure B)

*Continue to Kit Assembly*

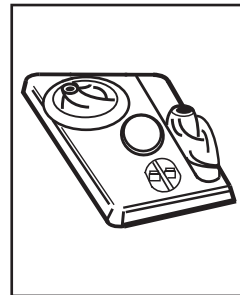

(Figure C)

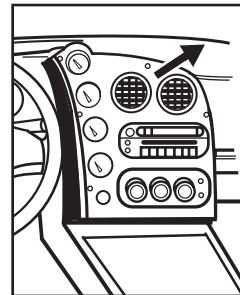

(Figure D)

### Jeep Grand Cherokee 1999-2004

1. Unclip and remove radio trim panel.
2. Remove (4) Phillips head screws securing the radio. Disconnect and remove the radio.

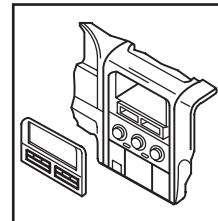

(Figure A)

*Continue to Kit Assembly*

# DASH DISASSEMBLY

## Dodge Dakota 2001-2004 / Durango 2001-2003

1. Remove (3) T-20 Torx screws from the bottom edge of the panel below the steering column and unsnap the panel to remove panel.
2. Remove (2) Phillips screws from the instrument cluster panel above gauges.
3. Remove (3) T-20 Torx screws from the bottom of the steering column shroud and unsnap and remove the top half of the shroud.
4. Unsnap and remove entire panel surrounding radio, A/C controls, and instrument cluster.
5. Remove (4) Phillips screws securing radio. Disconnect and remove radio.

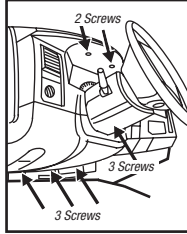

(Figure A)

*Continue to Kit Assembly*

## Jeep Liberty 2002-2007

1. Remove ashtray and remove one Phillips screw exposed.
2. Unclip and remove radio/climate control panel.
3. Remove (4) Phillips screws securing radio. Disconnect and remove radio.

*Continue to Kit Assembly*

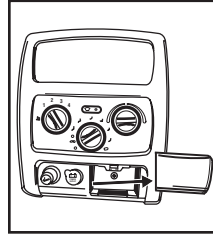

(Figure A)

## Jeep Wrangler 2003-2006

1. Unsnap and remove defroster grille panel near windshield.
2. Remove (2) Phillips screws exposed at the top of the center dash panel and unsnap and remove panel.
3. Remove glove box door to access one 10mm nut on back of radio.
4. Remove (4) Phillips screws securing radio. Disconnect and remove radio.

*Continue to Kit Assembly*

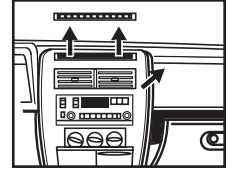

(Figure A)



### KIT ASSEMBLY

1. Remove the metal DIN sleeve from the aftermarket radio.
2. Slide the sleeve into the **radio housing** and secure by bending the metal locking tabs down.
3. Slide the radio into the sleeve until it clicks in. (Figure A)
4. Locate the factory wiring harness and antenna connector in the dash. Metra recommends using the proper mating adapter from Metra or AXCESS. Test the radio for proper operation.
5. Reassemble the dash in reverse order of disassembly.

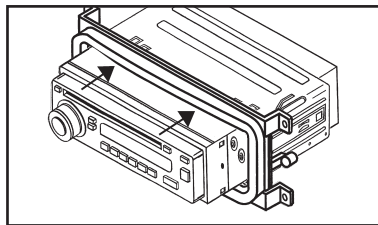

(Figure A)

If you are having difficulties with the installation of this product, contact our Tech Support line either by phone at **386-257-1187**, or email at **techsupport@metra-autosound.com**. Before doing so, look over the instruction booklet a second time and ensure that the installation was performed exactly as the instruction booklet is stated. Have the vehicle apart and ready to perform troubleshooting steps before contacting Metra/Axxess Tech Support.



#### KNOWLEDGE IS POWER

Enhance your installation and fabrication skills by enrolling in the most recognized and respected mobile electronics school in our industry. Log onto [www.installerinstitute.com](http://www.installerinstitute.com) or call 800-354-6782 for more information and take steps toward a better tomorrow.



Metra recommends MECP certified technicians





## Chrysler 1974-2010

### CARACTERÍSTICAS DEL KIT

- Provisión de radio DIN

### INTRODUCCIÓN

- El WM-FJCK01 incluye dos carcasas de radio diferentes para cubrir una amplia gama de vehículos. Use la **Descripción de la aplicación** en la página 2 para hacer referencia a qué carcasa de radio usar, y también qué páginas de instrucciones seguir. Cada sección se configura como un capítulo con su propia tabla de contenido.

### COMPONENTES DEL KIT

- A1) Carcasa del radio (a) • A2) Espaciadores de apoyo (Avenger/Sebring) • B1) Carcasa del radio (b)

A1

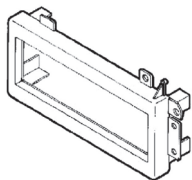

A2

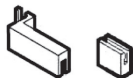

B1

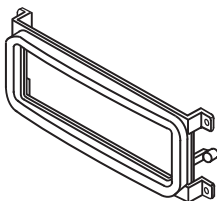

### APLICACIONES

Ver página 2

### INDICE

Descripción de las aplicaciones .....	2
Carcasa del radio (a) .....	3-19
Carcasa del radio (b) .....	20-23

### CABLEADO Y CONEXIONES DE ANTENA

(se venden por separado)

Arnés de cableado: Visite [metrafits.com](http://metrafits.com) para ver las opciones de cableado

Adaptador de antena: Visite [metrafits.com](http://metrafits.com) para ver las opciones de adaptadores de antena

### HERRAMIENTAS REQUERIDAS

- Destornillador Phillips • Herramienta de corte
- Torx #20 • Llave de tubo
- Herramienta para quitar paneles

***¡Precaución!*** Todos los accesorios, interruptores, paneles de controles de clima y especialmente las luces del indicador de las bolsas de aire deben estar conectados antes ciclar la ignición. Además, no quite el radio de fábrica con la llave en la posición o de encendido ni con el vehículo funcionando.

## DESCRIPCIÓN DE LAS APLICACIONES

### Carcasa del radio (a): Páginas 3-19

<b>Chrysler</b>		<b>Dodge</b>	
Cirrus	1995-2000	Aries	1981-1989
Concorde	1993-1997	Aspen	1976-1980
Cordoba	1975-1978	Avenger	1995-2000
Cordoba	1979-1983	Caravan	1984-1990
E-Class	1983-1984	Caravan	1991-1995
Fifth Avenue	1990-1994	Caravan	1996-2000
Imperial	1982-1983	Charger	1974-1978
Imperial	1990-1994	Charger	1983-1987
Laser	1984-1986	Dakota	1987-1996
LeBaron	1976-1981	Dakota	1997-2000
LeBaron	1982-1985	Daytona	1984-1989
LeBaron	1986-1994	Daytona	1990-1993
LeBaron GTS	1985-1994	Diplomat	1976-1989
LHS	1993-1997	Durango	1997-2000
Newport	1980-1981	Dynasty	1988-1993
New Yorker	1980-1981	Intrepid	1993-1997
New Yorker	1983-1987	Lancer	1985-1989
New Yorker	1988-1996	Magnum XE	1978-1979
Sebring	1995-2000	Mirada	1980-1983
Sebring (conv)	1996-2000	Neon	1994-1999
Town & Country		Omni	1978-1982
	1990-1995	Pickup	1974-1980
Town & Country		Pickup	1981-1993
	1996-2000	Ram	1994-2001

<b>Dodge (Cont)</b>	
Ramcharger	1974-1980
Ramcharger	1981-1993
Rampage	1978-1982
Shadow	1987-1994
Spirit	1989-1995
SI Regis	1979-1981
Stratus	1995-2000
Van	1978-2003
024	1978-1982
400	1982-1983
600	1983-1987

<b>Eagle</b>	
Vision	1993-1997

<b>Ford</b>	
Aerostar	1985-1991
Bronco II	1985-1988
Crown Victoria	1979-1990
LTD	1979-1990
Ranger (mini)	1985-1988
Thunderbird	1985-1988

<b>Jeep</b>	
Cherokee	1997-2001
Grand Cherokee	1993-1995
Grand Cherokee	1996-1998
Wrangler	1997-2002

<b>Lincoln</b>	
Continental	1985-1987
Mark VII	1984-1989

<b>Mercury</b>	
Cougar	1985-1988
Grand Marquis	1979-1990
Marquis	1979-1990

<b>Plymouth</b>	
Acclaim	1989-1995
Breeze	1996-2000
Caravelle	1985-1987
Fury	1975-1978
Gran Fury	1975-1985
Horizon	1978-1982
Neon	1994-1999
Reliant	1981-1989

<b>Plymouth (Cont)</b>	
Scamp	1983-1984
Sundance	1987-1994
TC3	1978-1982
Trailduster	1974-1980
Trailduster	1981
Turismo	1983-1987
Van	1978-2003
Volare	1976-1980
Voyager	1984-1990
Voyager	1991-1995
Voyager	1996-2000

### Carcasa del radio (b): Páginas 20-23

<b>Chrysler</b>	
300M	1999-2004
Concorde	1998-2004
LHS	1999-2001
PT Cruiser	2001-2005
Sebring	2001-2006
Town & Country	2001-2007

<b>Dodge</b>	
Caravan	2001-2007
Dakota	2001-2004
Durango	2001-2003
Intrepid	1998-2004
Neon	2000-2006
Ram	2002-2005
Stratus	2001-2006
Viper	2003-2010

<b>Jeep</b>	
Grand Cherokee	1999-2004
Liberty	2002-2007
Wrangler	2003-2006

<b>Plymouth</b>	
Neon	2000-2001

# CARCARA DE RADIO (A) INSTRUCCIONES

## CARACTERÍSTICAS DEL KIT

- Provisión de radio DIN

## COMPONENTES DEL KIT

- A) Carcasa del radio (a) • A) Espaciadores de apoyo (Avenger/Sebring)

## CABLEADO Y CONEXIONES DE ANTENA (se venden por separado)

Arnés de cableado: Visite [metrafits.com](http://metrafits.com) para ver las opciones de cableado

Adaptador de antena: No se requiere

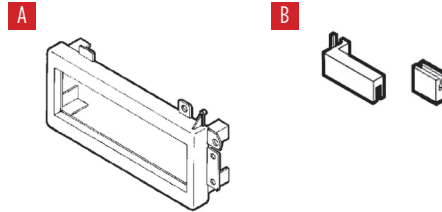

## INDICE

Desmontaje del tablero .....	4-17
Ensamble del kit .....	17
Ensamble del kit final.....	18-19

## HERRAMIENTAS REQUERIDAS

- Destornillador Phillips • Herramienta de corte
- Llave de tubo

## APLICACIONES

<b>Chrysler</b>	Newport	1980-1981	Caravan	1996-2000	Omni	1978-1982	<b>Eagle</b>	Lincoln	Neon	1994-1999			
Cirrus	1995-2000	New Yorker	1980-1981	Charger	1974-1978	Pickup	Vision	1993-1997	1985-1987	Reliant	1981-1989		
Concorde	1993-1997	New Yorker	1983-1987	Charger	1983-1987	Pickup	<b>Ford</b>	Mark VII	1984-1989	Scamp	1983-1984		
Cordoba	1975-1978	New Yorker	1988-1996	Dakota	1987-1996	Ram	Aerostar			Sundance	1987-1994		
Cordoba	1979-1983	Sebring	1995-2000	Dakota	1997-2000	Ramcharger	Bronco II	1985-1991	<b>Mercury</b>	TC3	1978-1982		
E-Class	1983-1984	Sebring (conv)	1996-2000	Daytona	1984-1989	Ramcharger	Crown Victoria	1985-1988	Cougar	1985-1988	Trailduster	1974-1980	
Fifth Avenue	1990-1994	Town & Country	1990-1995	Daytona	1990-1993	Rampage	LTD	1979-1990	Grand Marquis	1979-1990	Trailduster	1981	
Imperial	1982-1983	Town & Country	1996-2000	Diplomat	1976-1989	Shadow	Ranger (mini)	1985-1988	Marquis	1979-1990	Turismo	1983-1987	
Imperial	1990-1994	<b>Dodge</b>		Durango	1997-2000	Spirit	Thunderbird	1985-1988	<b>Plymouth</b>		Van	1978-2003	
Laser	1984-1986	Aries	1981-1989	Dynasty	1988-1993	Spirit			Acclaim	1989-1995	Volare	1976-1980	
LeBaron	1976-1981	Aspen	1976-1980	Dynasty	1993-1997	Stratus			Breeze	1996-2000	Voyager	1984-1990	
LeBaron	1982-1985	Avenger	1995-2000	Lancer	1985-1989	Van	<b>Jeep</b>	Cherokee	1997-2001	Caravelle	1985-1987	Voyager	1991-1995
LeBaron	1986-1994	Caravan	1984-1990	Magnum XE	1978-1979	024		Grand Cherokee	1993-1995	Fury	1975-1978	Voyager	1996-2000
LeBaron GTS	1985-1994	Caravan	1991-1995	Mirada	1980-1983	400		Grand Cherokee	1996-1998	Gran Fury	1975-1985		
LHS	1993-1997	Caravan		Neon	1994-1999	600		Wrangler	1997-2002	Horizon	1978-1982		

## DESMONTAJE DEL TABLERO

**Chrysler Cirrus 1995-2000**  
**Dodge Stratus 1995-2000**  
**Plymouth Breeze 1996-2000**

1. Con un destornillador de paleta, haga palanca hacia afuera en los bordes del bisel de la moldura de la radio. Desenganche el bisel y quite. (Figura A)
2. Quite los (2) tornillos de cabeza hexagonal de 3/8" que sujetan la radio de fábrica y desconecte el cableado. (Figura A)
3. Corte y quite todas las pestañas de montaje de la carcasa de la radio, EXCEPTO las pestañas sombreadas. (Figura B)

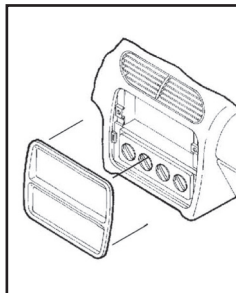

(Figura A)

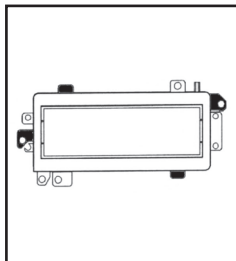

(Figura B)

*Continúe con el  
Ensamble del Kit*

**Chrysler Concorde/LHS 1993-1997**  
**Dodge Intrepid 1993-1997**  
**Eagle Vision 1993-1997**

1. Desenganche el bisel de la moldura de la radio y quite. (Figura A)
2. Quite los (2) tornillos de cabeza hexagonal de 3/8" que sujetan la radio de fábrica y desconecte el cableado.
3. Corte y quite todas las pestañas de montaje de la carcasa de la radio, EXCEPTO las pestañas sombreadas. (Figura B)

*Continúe con el  
Ensamble del Kit*

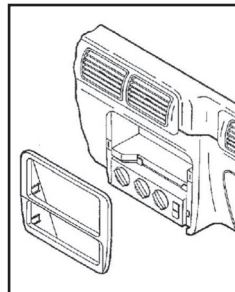

(Figura A)

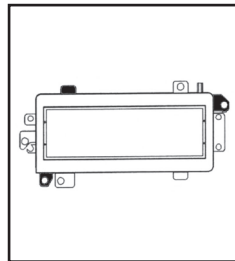

(Figura B)

**Chrysler Cordoba 1975-1978**  
**Dodge Charger 1974-1978 / Magnum XE 1978-1979**  
**Plymouth Fury 1975-1978**

1. Quite los (4) tornillos Phillips del borde inferior del bisel de la moldura de la radio.
2. Quite los (2) tornillos Phillips de arriba de la abertura de la radio. (Figura A)
3. Destornille el anillo de retención que fija el control del espejo remoto y retire el bisel.
4. Quite los (2) tornillos de cabeza hexagonal de 3/8" que sujetan la radio de fábrica y desconecte el cableado.
5. Corte y quite todas las pestañas de montaje de la carcasa de la radio, EXCEPTO las pestañas sombreadas. (Figura B)

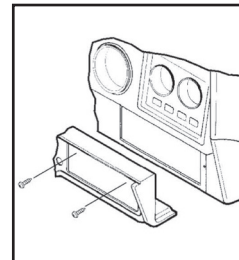

(Figura A)

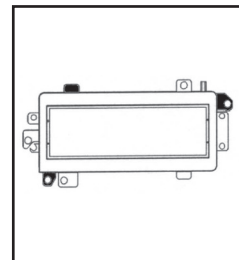

(Figura B)

*Continúe con el  
Ensamble del Kit*

## DESMONTAJE DEL TABLERO

**Chrysler Cordoba 1979-1985 / Imperial 1982-1983 / Newport/New Yorker 1980-1981  
Dodge Mirada 1980-1983/St. Regis 1979-1981**

1. Retire (2) tornillos Phillips del borde inferior del bisel de la moldura del radio. (Figura A)
2. Quite los (2) tornillos Phillips de arriba de la abertura de la radio.
3. Destornille el anillo de retención que fija el control del espejo remoto y retire el bisel.
4. Quite los (2) tornillos de cabeza hexagonal de 3/8" que sujetan la radio de fábrica y desconecte el cableado.
5. Corte y quite todas las pestañas de montaje de la carcasa de la radio, EXCEPTO las pestañas sombreadas. (Figura B)

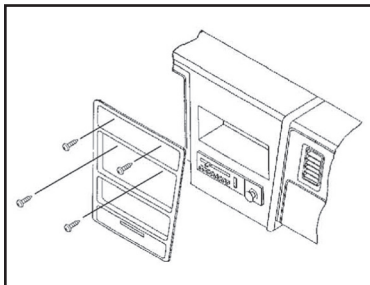

(Figura A)

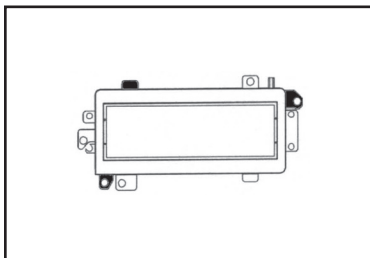

(Figura B)

*Continúe con el Ensamble del Kit*

**Chrysler E-Class 1983-1984 / LeBaron 1982-1985 / New Yorker 1983-1987  
Dodge Aries 1981-1989 / 400 1982-1983 / 600 1983-1987  
Plymouth Caravelle 1985-1987 / Reliant 1981-1989**

1. Quite los (3) tornillos Phillips del borde superior del bisel de la moldura del tablero.
2. Quite los (3) tornillos Phillips del borde inferior del bisel de la moldura del tablero.
3. Desenganche el bisel y desconecte el cableado. (Figura A)
4. Quite los (2) tornillos de cabeza hexagonal de 3/8" que sujetan la radio de fábrica y desconecte el cableado.
5. Corte y quite todas las pestañas de montaje de la carcasa de la radio, EXCEPTO las pestañas sombreadas. (Figura B)

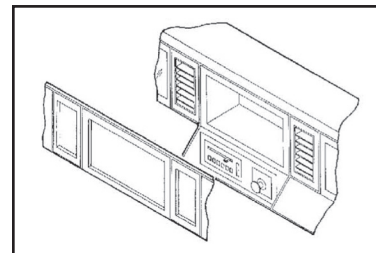

(Figura A)

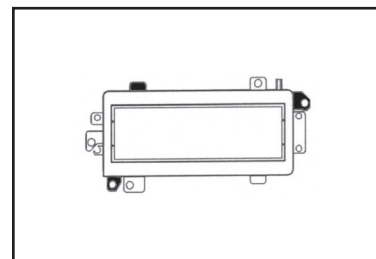

(Figura B)

*Continúe con el Ensamble del Kit*

## DESMONTAJE DEL TABLERO

**Chrysler Fifth Avenue 1990-1994 / Imperial 1990-1994 /  
Chrysler New Yorker 1988-1996  
Dodge Dynasty 1988-1993**

1. Quite los (2) tornillos Phillips de arriba de la abertura de la radio. (Figura A)
2. Retire los (2) tornillos Phillips de arriba de los controles del clima. (Figura A)
3. Desenganche el bisel de la moldura del tablero y retire.
4. Quite los (2) tornillos de cabeza hexagonal de 3/8" que sujetan la radio de fábrica y desconecte el cableado. (Figura A)
5. Corte y quite todas las pestañas de montaje de la carcasa de la radio, EXCEPTO las pestañas sombreadas. (Figura B)

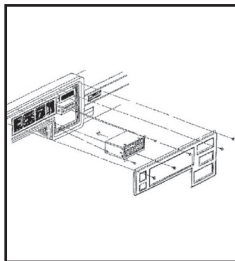

(Figura A)

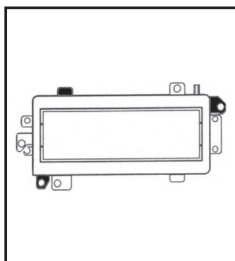

(Figura B)

Continúe con el  
Ensamble del Kit

**Chrysler Laser 1984-1986  
Dodge Daytona 1984-1989**

1. Quite los (2) tornillos Phillips de la base del bisel de la moldura del tablero.
2. Jale hacia afuera el borde inferior del bisel y retírelo. (Figura A)
3. Quite los (2) tornillos de cabeza hexagonal de 3/8" que sujetan la radio de fábrica y desconecte el cableado.
4. Corte y quite todas las pestañas de montaje de la carcasa de la radio, EXCEPTO las pestañas sombreadas. (Figura B)

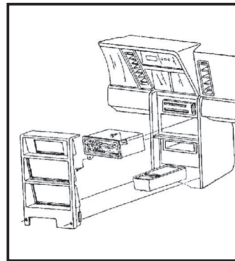

(Figura A)

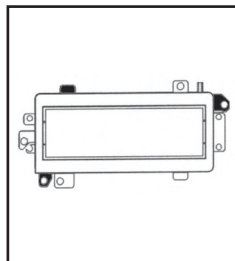

(Figura B)

Continúe con el  
Ensamble del Kit

**Chrysler LeBaron 1986-1994**

1. Quite (1) tornillo Phillips de la esquina inferior del bisel de la moldura del tablero.
2. Desenganche el bisel y retire.
3. Quite los (2) tornillos Phillips del panel derecho de la consola y retire el panel. (Figura A)
4. Remove (2) hex-head screws securing the factory radio and disconnect the wiring.
5. Corte y quite todas las pestañas de montaje de la carcasa de la radio, EXCEPTO las pestañas sombreadas. (Figura B)

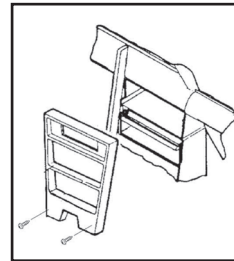

(Figura A)

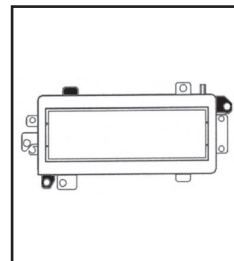

(Figura B)

Continúe con el  
Ensamble del Kit

## DESMONTAJE DEL TABLERO

**Chrysler LeBaron GTS 1985-1994,  
Dodge Lancer 1985-1989**

1. Quite los (5) tornillos de cabeza Torx de la parte superior del bisel de la moldura del tablero.
2. Quite los (2) tornillos de cabeza Torx de abajo de la apertura de la radio.
3. Quite (1) tornillo de cabeza Torx de la esquina superior izquierda de la apertura de la radio.
4. Quite los (4) tornillos de cabeza Torx del área inferior del bisel de la moldura del tablero. (Figura A)
5. Desenganche el bisel y retire. Quite los (2) tornillos de cabeza hexagonal de 3/8" que sujetan la radio de fábrica y desconecte el cableado.
6. Corte y quite todas las pestañas de montaje de la carcasa de la radio, EXCEPTO las pestañas sombreadas. (Figura B)

*Continúe con el Ensamble del Kit*

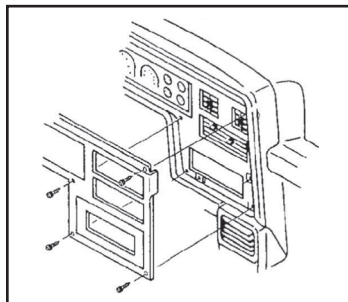

(Figura A)

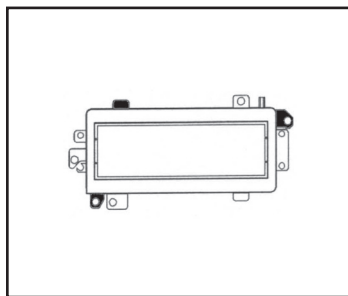

(Figura B)

**Chrysler LeBaron 1976-1981  
Dodge Diplomat 1976-1989 / Aspen 1976-1980,  
Plymouth Gran Fury 1975-1985 / Volare 1976-1980**

1. Quite los (4) tornillos de la parte superior del bisel de la moldura del tablero y luego quite los (4) de la parte inferior del bisel de la moldura del tablero. (Figura A)
2. Quite los (2) tornillos de cabeza hexagonal de 3/8" que sujetan la radio de fábrica y desconecte el cableado.
3. Corte y quite todas las pestañas de montaje de la carcasa de la radio, EXCEPTO las pestañas sombreadas. (Figura B)

*Continúe con el Ensamble del Kit*

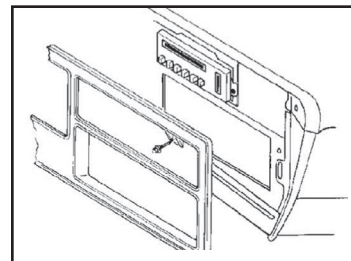

(Figura A)

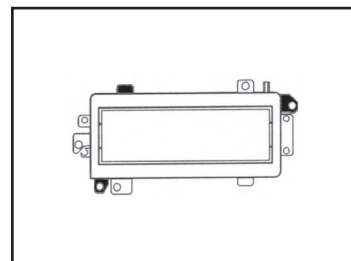

(Figura B)

## DESMONTAJE DEL TABLERO

### Chrysler Sebring (convertible) 1996-2000

1. Desenganche el bisel de la moldura de la radio y quite. (Figura A)
2. Quite los (2) tornillos de cabeza hexagonal de 3/8" que sujetan la radio de fábrica y desconecte el cableado.
3. Corte y quite todas las pestañas de montaje de la carcasa de la radio, EXCEPTO las pestañas sombreadas. (Figura B)

Continúe con el  
Ensamble del Kit

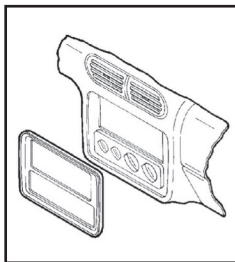

(Figura A)

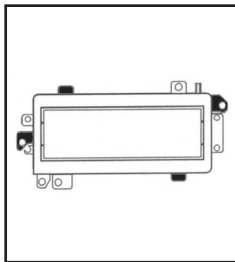

(Figura B)

### Dodge Sebring 1995-2000 / Avenger 1995-2000

1. Desenganche el bisel de la moldura de la radio y quite. (Figura A)
2. Quite los (2) tornillos #10 Phillips que sujetan la radio de fábrica y desconecte el cableado.
3. Corte y quite todas las pestañas de montaje de la carcasa de la radio, EXCEPTO las pestañas sombreadas. (Figura B)

Continúe con el  
Ensamble del Kit

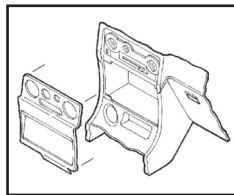

(Figura A)

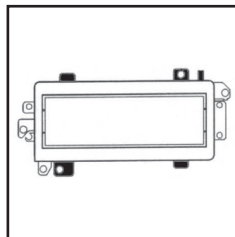

(Figura B)

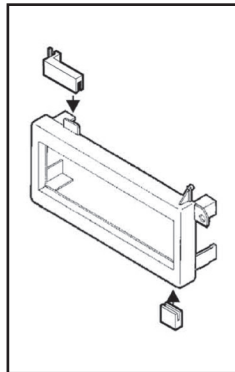

(Figura C)

### Dodge Caravan 1991-1995 Plymouth Voyager 1991-1995

1. Quite el encendedor.
2. Con una herramienta de remoción de panel, haga palanca para sacar el bisel de la moldura del tablero y retire. (Figura A)
3. Quite los (2) tornillos de 3/8" que sujetan la radio de fábrica y desconecte el cableado.
4. Corte y quite todas las pestañas de montaje de la carcasa de la radio, EXCEPTO las pestañas sombreadas. (Figura B)

Continúe con el  
Ensamble del Kit

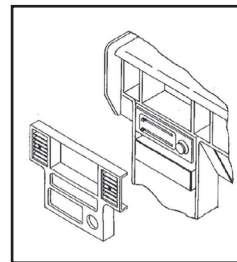

(Figura A)

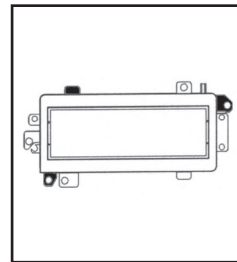

(Figura B)



## DESMONTAJE DEL TABLERO

**Chrysler Town & Country 1990-1995**  
**Dodge Caravan 1984-1990**  
**Plymouth Voyager 1984-1990**

1. Alcance detrás del cenicero y libere la pestaña trasera en la carcasa del cenicero.
2. Quite los (2) tornillos del borde inferior del bisel de la moldura de la radio. Quite los (3) tornillos del borde superior del bisel de la moldura del tablero. (Figura A)
3. Suelte a presión el borde izquierdo del bisel y retírelo.
4. Quite los (2) tornillos de cabeza hexagonal de 3/8" que sujetan la radio de fábrica y desconecte el cableado.
5. Corte y quite todas las pestañas de montaje de la carcasa de la radio, EXCEPTO las pestañas sombreadas. (Figura B)

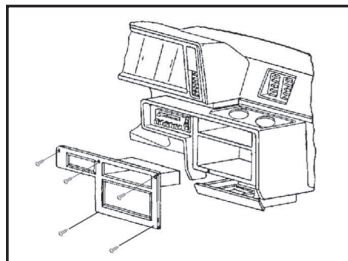

(Figura A)

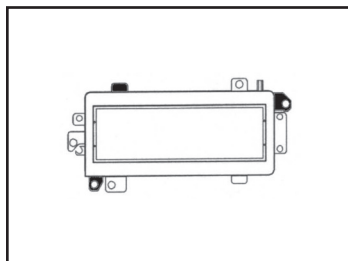

(Figura B)

*Continúe con el Ensamble del Kit*

**Chrysler Town & Country 1996-2000**  
**Dodge Caravan 1996-2000**  
**Plymouth Voyager 1996-2000**

1. Jale el cenicero hacia adelante. Suelte a presión la pieza de moldura de plástico localizada debajo del bisel de la moldura de la radio y quite los (2) tornillos Phillips expuestos. (Figura A)
2. Quite los (2) tornillos Phillips de arriba de la abertura de la radio.
3. Desenganche el bisel de la moldura del tablero, desconecte el cableado del control de clima y quite el bisel.
4. Quite los (2) tornillos de cabeza hexagonal de 3/8" que sujetan la radio de fábrica y desconecte el cableado.
5. Corte y quite todas las pestañas de montaje de la carcasa de la radio, EXCEPTO las pestañas sombreadas. (Figura B)

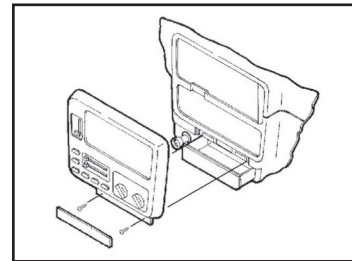

(Figura A)

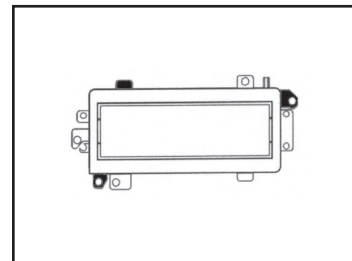

(Figura B)

*Continúe con el Ensamble del Kit*

## DESMONTAJE DEL TABLERO

### Dodge Charger 1983-1987 Plymouth Turismo 1983-1987

1. Desenganche el bisel de la moldura de la radio y quite.
2. Quite los (2) tornillos de cabeza hexagonal de 3/8" que sujetan la radio de fábrica y desconecte el cableado.
3. Corte y quite todas las pestañas de montaje de la carcasa de la radio, EXCEPTO las pestañas sombreadas. (Figura B)

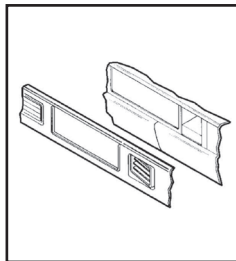

(Figura A)

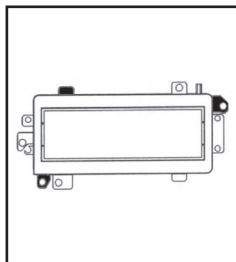

(Figura B)

Continúe con el  
Ensamble del Kit

### Dodge Dakota 1987-1996

1. Quite los (8) tornillos de cabeza Torx del bisel de la moldura del tablero.
2. Quite los (2) tornillos Phillips de la moldura de la columna de dirección y retire.
3. Quite (1) tornillo Phillips expuesto de cada lado de la columna de dirección.
4. Desenganche el bisel de la moldura del tablero y retire. (Figura A)
5. Retire (2) tornillos Phillips que aseguran la radio de fábrica y desconecte el cableado.
6. Corte y quite todas las pestañas de montaje de la carcasa de la radio, EXCEPTO las pestañas sombreadas. (Figura B)

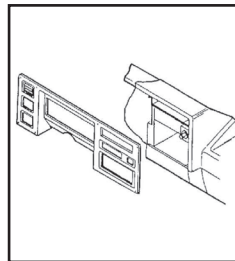

(Figura A)

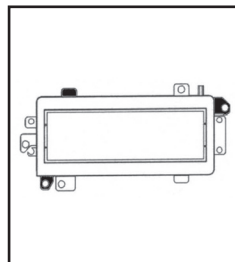

(Figura B)

Continúe con el  
Ensamble del Kit

### Dodge Dakota 1997-2000

1. Desenganche todo el embellecedor del tablero. (Figura A)
2. Quite los (2) tornillos de cabeza hexagonal de 3/8" que sujetan la radio de fábrica y desconecte el cableado.
3. Corte y quite todas las pestañas de montaje de la carcasa de la radio, EXCEPTO las pestañas sombreadas. (Figura B)

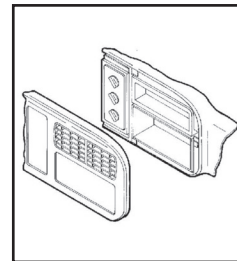

(Figura A)

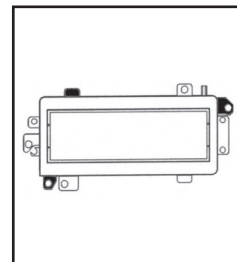

(Figura B)

Continúe con el  
Ensamble del Kit

## DESMONTAJE DEL TABLERO

### Dodge Daytona 1990-1993

1. Saque el bisel de la moldura del tablero y retire. (Figura A)
2. Quite los (2) tornillos a cada lado de la consola inferior (esto permitirá retirar la radio con más facilidad).
3. Retire (2) tornillos que aseguran la radio de fábrica y desconecte el cableado.
4. Corte y quite todas las pestañas de montaje de la carcasa de la radio, EXCEPTO las pestañas sombreadas. (Figura B)

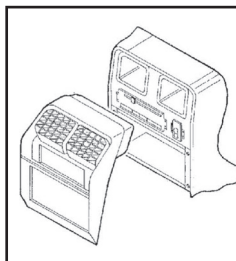

(Figura A)

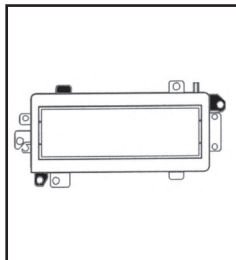

(Figura B)

Continúe con el  
Ensamble del Kit

### Dodge Durango 1997-2000

1. Desenganche todo el embellecedor del tablero. (Figura A)
2. Quite los (2) tornillos de cabeza hexagonal de 3/8" que sujetan la radio de fábrica y desconecte el cableado.
3. Corte y quite todas las pestañas de montaje de la carcasa de la radio, EXCEPTO las pestañas sombreadas. (Figura B)

Continúe con el  
Ensamble del Kit

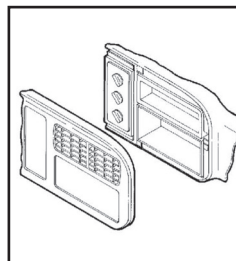

(Figura A)

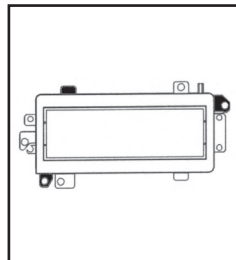

(Figura B)

### Dodge Neon 1994-1999 Plymouth Neon 1994-1999

1. Quite el cenicero. Desenganche el bisel de la moldura de la radio y retire. (Figura A)
2. Quite los (2) tornillos de cabeza hexagonal de 3/8" que sujetan la radio de fábrica y desconecte el cableado.
3. Corte y quite todas las pestañas de montaje de la carcasa de la radio, EXCEPTO las pestañas sombreadas. (Figura B)

Continúe con el  
Ensamble del Kit

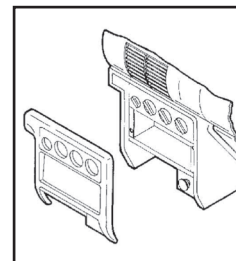

(Figura A)

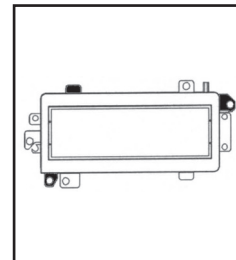

(Figura B)

## DESMONTAJE DEL TABLERO

### Dodge Omni/024/Rampage 1978-1982 Plymouth Horizon/TC3 1978-1982/Scamp 1983-1984

1. Quite los (7) tornillos Phillips del bisel de la moldura del tablero y retire el bisel. (Figura A)
2. Quite los (2) tornillos de cabeza hexagonal de 3/8" que sujetan la radio de fábrica y desconecte el cableado.
3. Corte y quite todas las pestañas de montaje de la carcasa de la radio, EXCEPTO las pestañas sombreadas. (Figura B)

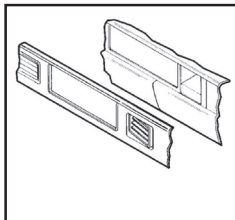

(Figura A)

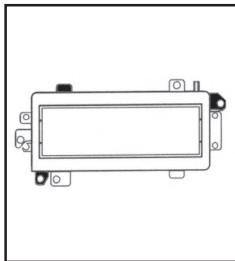

(Figura B)

Continúe con el  
Ensamble del Kit

### Dodge Pickup/Ramcharger 1974-1980 Plymouth Trailduster 1974-1980

1. Retire (4) tornillos Phillips del borde superior del embellecedor del tablero. (Figura A)
2. Quite los (7) tornillos Phillips de la parte frontal del bisel de la moldura del tablero.
3. Retire (3) tornillos Phillips debajo del embellecedor del tablero.
4. Desenganche el bisel y retire. Quite los (2) tornillos de cabeza hexagonal de 3/8" que sujetan la radio de fábrica y desconecte el cableado.
5. Corte y quite todas las pestañas de montaje de la carcasa de la radio, EXCEPTO las pestañas sombreadas. (Figura B)

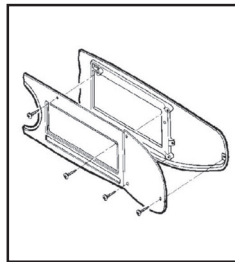

(Figura A)

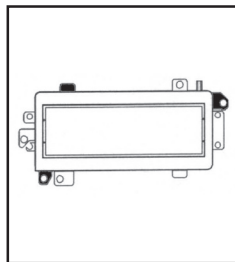

(Figura B)

Continúe con el  
Ensamble del Kit

### Dodge Pickup/Ramcharger 1981-1993 Plymouth Trailduster 1981

1. Retire (5) tornillos Phillips del borde del embellecedor del tablero.
2. Retire (1) tornillo Phillips sobre la abertura de la radio.
3. Haga palanca hacia afuera en el borde inferior del bisel y retírelo. (Figura A)
4. Quite los (2) tornillos de cabeza hexagonal de 3/8" que sujetan la radio de fábrica y desconecte el cableado.
5. Corte y quite todas las pestañas de montaje de la carcasa de la radio, EXCEPTO las pestañas sombreadas. (Figura B)

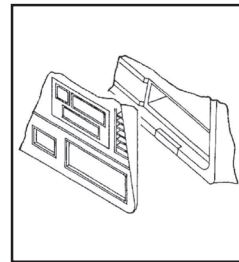

(Figura A)

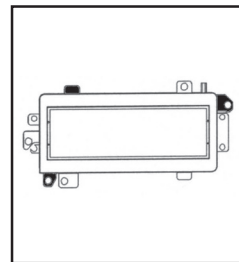

(Figura B)

Continúe con el  
Ensamble del Kit

## DESMONTAJE DEL TABLERO

### Dodge Ram 1994-2001

1. Remove the ashtray. Quite el cenicero y los (2) tornillos Phillips expuestos en la cavidad del cenicero y retire el soporte del cenicero. (Figura A)
2. Quite el portavasos. Quite el cenicero y los (2) tornillos Phillips expuestos en la cavidad del portavasos y retire el soporte del portavasos. (Figura A)
3. Desenganche el bisel de la moldura del tablero; jale el bisel encima de la columna de dirección y quítelo.
4. Quite los (2) tornillos de cabeza hexagonal de 3/8" que sujetan la radio de fábrica y desconecte el cableado.
5. Corte y quite todas las pestañas de montaje de la carcasa de la radio, EXCEPTO las pestañas sombreadas. (Figura B)

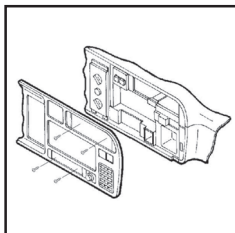

(Figura A)

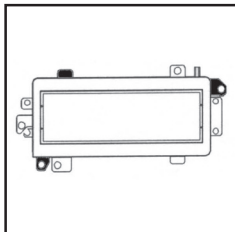

(Figura B)

Continúe con el Ensamble del Kit

### Dodge Shadow 1987-1994 Plymouth Sundance 1987-1994

1. Quite el cenicero. Desenganche el bisel de la moldura del tablero y retire. (Figura A)
2. Retire (1) tornillo Phillips de la moldura lateral de la consola y retire.
3. Quite los (2) tornillos de cabeza hexagonal de 3/8" que sujetan la radio de fábrica y desconecte el cableado.
4. Corte y quite todas las pestañas de montaje de la carcasa de la radio, EXCEPTO las pestañas sombreadas. (Figura B)

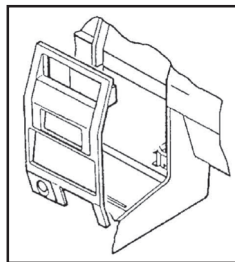

(Figura A)

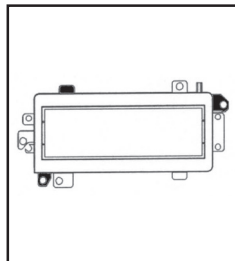

(Figura B)

Continúe con el  
Ensamble del Kit

### Dodge Spirit 1989-1995 Plymouth Acclaim 1989-1995

1. Desenganche el bisel de la moldura del tablero y retire. Quite los tornillos que sujetan las piezas de moldura de la consola lateral. (Figura A)
2. Jale la pieza derecha de moldura hacia afuera y retire (1) perno de cabeza hexagonal expuesto.
3. Quite (1) perno de cabeza hexagonal que sujeta la esquina inferior izquierda de la radio de fábrica y desconecte el cableado.
4. Corte y quite todas las pestañas de montaje de la carcasa de la radio, EXCEPTO las pestañas sombreadas. (Figura B)

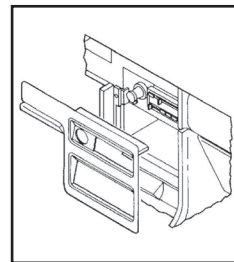

(Figura A)

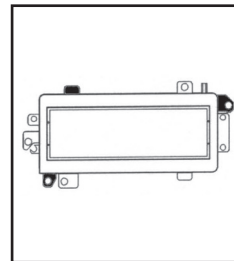

(Figura B)

Continúe con el  
Ensamble del Kit

## DESMONTAJE DEL TABLERO

### Dodge Van 1978-2003 Plymouth Van 1978-2003

1. Abra la guantera y quite los (2) tornillos Phillips expuestos.
2. Retire (5) tornillos Phillips de la parte inferior del embellecedor del tablero.
3. Desenganche el borde superior del bisel y retire.
4. Quite los (2) tornillos de cabeza hexagonal de 3/8" que sujetan la radio de fábrica y desconecte el cableado.
5. Corte y quite todas las pestañas de montaje de la carcasa de la radio, EXCEPTO las pestañas sombreadas.

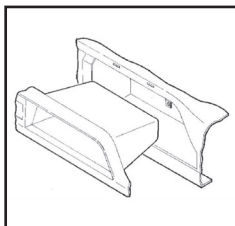

(Figura A)

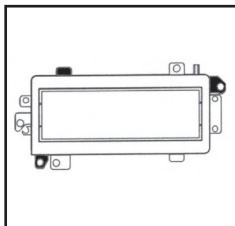

(Figura B)

### For Dodge Van 1998-2003

1. Desenganche y quite todo el panel que rodea la radio y el conjunto de instrumentos.
2. Quite los (2) tornillos de cabeza hexagonal de 3/8" que sujetan la radio de fábrica y desconecte el cableado.

Continúe con el *Ensamble del Kit*

### Ford Aerostar 1985-1991

1. Retire (2) tornillos Phillips de la base del panel de tablero. (Figura A)
2. Haga palanca hacia abajo en las (2) pestañas localizadas en la parte superior del bisel de la moldura de la radio y quite el bisel. (Figura A)
3. Retire (4) tornillos que sujetan la radio de fábrica y desconecte el cableado.
4. Corte y quite todas las pestañas de montaje de la carcasa de la radio, EXCEPTO las pestañas sombreadas. (Figura B)

Continúe con el  
*Ensamble del Kit*

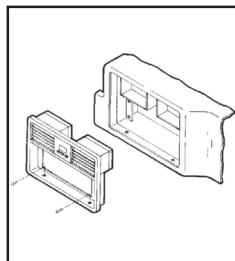

(Figura A)

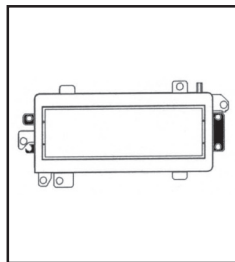

(Figura B)

### Ford Bronco II/Ranger (mini) 1985-1988

1. Retire (4) tornillos Phillips del borde superior del embellecedor del tablero. (Figura A)
2. Quite la perilla del interruptor de las luces, el encendedor y el cenicero.
3. Suelte a presión la moldura debajo del bisel de la moldura del tablero y quite los (4) tornillos expuestos. (Figura A)
4. Retire (4) tornillos que sujetan la radio de fábrica y desconecte el cableado.
5. Corte y quite todas las pestañas de montaje de la carcasa de la radio, EXCEPTO las pestañas sombreadas. (Figura B)

Continúe con el  
*Ensamble del Kit*

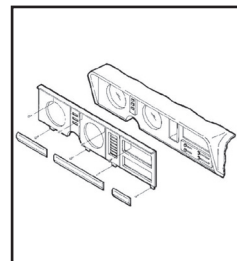

(Figura A)

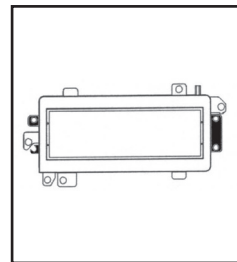

(Figura B)

## DESMONTAJE DEL TABLERO

### Ford Crown Victoria/LTD 1979-1990, Mercury Grand Marquis/Marquis 1979-1990

1. Abra el cenicero y retire los (2) tornillos Phillips expuestos. (Figura A)
2. Retire el embellecedor del tablero.
3. Retire (4) tornillos que sujetan la radio de fábrica y desconecte el cableado.
4. Corte y quite todas las pestañas de montaje de la carcasa de la radio, EXCEPTO las pestañas sombreadas. (Figura B)

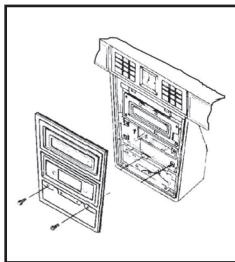

(Figura A)

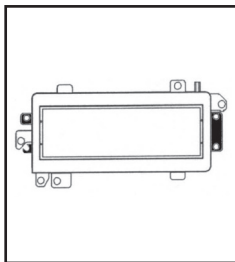

(Figura B)

Continúe con el  
Ensamble del Kit

### Ford Thunderbird 1985-1988 Mercury Cougar 1985-1988

1. Retire (2) tornillos de la parte superior del embellecedor del tablero. (Figura A)
2. Abra el cenicero y retire los (2) tornillos expuestos. (Figura A)
3. Retire el embellecedor del tablero. Retire (4) tornillos que sujetan la radio de fábrica y desconecte el cableado.
4. Corte y quite todas las pestañas de montaje de la carcasa de la radio, EXCEPTO las pestañas sombreadas. (Figura B)

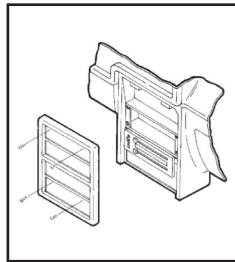

(Figura A)

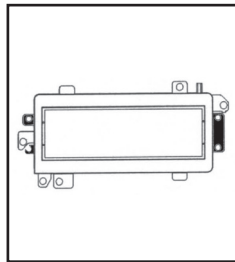

(Figura B)

Continúe con el  
Ensamble del Kit

### Jeep Cherokee 1997-2001

1. Desenganche el embellecedor del tablero. (Figura A)
2. Quite los (2) tornillos de cabeza hexagonal #10 Phillips que sujetan la radio de fábrica y desconecte el cableado.
3. Corte y quite todas las pestañas de montaje de la carcasa de la radio, EXCEPTO las pestañas sombreadas. (Figura B)

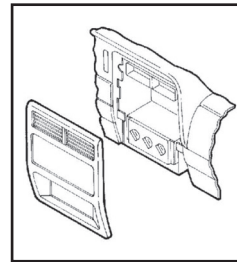

(Figura A)

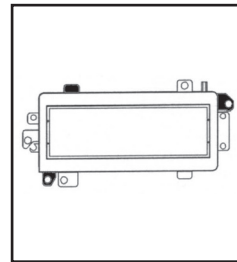

(Figura B)

Continúe con el  
Ensamble del Kit

## DESMONTAJE DEL TABLERO

### Jeep Grand Cherokee 1993-1995

1. Retire (2) tornillos Phillips de la parte inferior del embellecedor del tablero. (Figura A)
2. Quite los (2) tornillos Phillips de arriba de la abertura de la radio. (Figura A)
3. Quite los (2) tornillos Phillips a la izquierda de la columna de dirección. (Figura A)
4. Quite (1) tornillo Phillips a la derecha de la columna de dirección. Desenganche el bisel de la moldura del tablero y desconecte el cableado.
5. Corte y quite todas las pestañas de montaje de la carcasa de la radio, EXCEPTO las pestañas sombreadas. (Figura B)

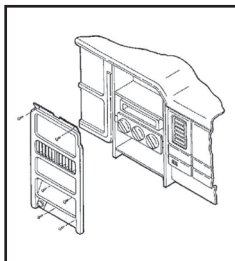

(Figura A)

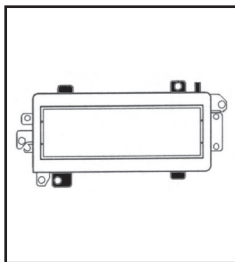

(Figura B)

Continúe con el  
Ensamble del Kit

### Jeep Grand Cherokee 1996-1998

1. Suelte a presión el panel de la moldura del control del clima/control de los limpiadores y retire.
2. Quite los (5) tornillos Phillips de la parte superior del bisel de la moldura de la radio/conjunto de instrumentos.
3. Retire (4) tornillos Phillips de la parte inferior del radio /bisel de la moldura del instrumentos.
4. Haga palanca hacia afuera en el borde inferior del bisel y retírelo. (Figura A)
5. Quite los (2) tornillos de cabeza hexagonal de 3/8" que sujetan la radio de fábrica y desconecte el cableado.
6. Corte y quite todas las pestañas de montaje de la carcasa de la radio, EXCEPTO las pestañas sombreadas. (Figura B)

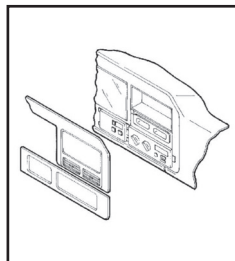

(Figura A)

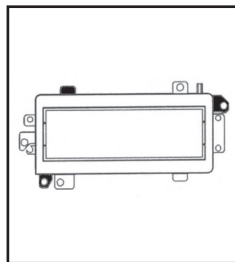

(Figura B)

Continúe con el  
Ensamble del Kit

### Jeep Wrangler 1997-2002

1. Quite el cenicero y (1) tornillo Phillips expuesto en la cavidad del cenicero. (Figura A)
2. Haga palanca hacia afuera en la cubierta superior del panel de instrumentos y quite los (2) tornillos Phillips expuestos.
3. Haga palanca hacia afuera el borde inferior del bisel de la moldura del tablero y retírelo.
4. Quite los (2) tornillos de cabeza hexagonal de 3/8" que sujetan la radio de fábrica y desconecte el cableado.
5. Corte y quite todas las pestañas de montaje de la carcasa de la radio, EXCEPTO las pestañas sombreadas. (Figura B)

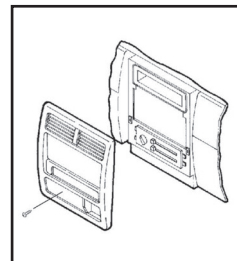

(Figura A)

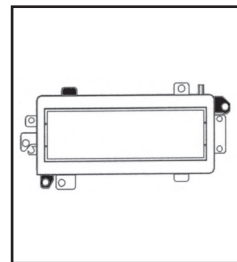

(Figura B)

Continúe con el  
Ensamble del Kit



## DESMONTAJE DEL TABLERO

### Lincoln Continental 1985-1987

1. Quite los (2) tornillos #8 de Phillips de debajo de la abertura de la radio. (Figura A)
2. Abra el cenicero y quite los (2) tornillos #8 Phillips (NO es necesario retirar el tornillo central). (Figura A)
3. Desenganche el bisel de la moldura del tablero y retire.
4. Retire (4) tornillos de cabeza hexagonal que aseguran la radio de fábrica y desconecte el cableado.
5. Corte y quite todas las pestañas de montaje de la carcasa de la radio, EXCEPTO las pestañas sombreadas. (Figura B)

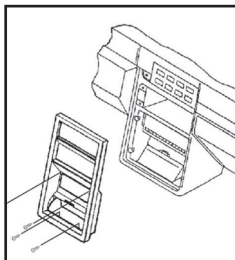

(Figura A)

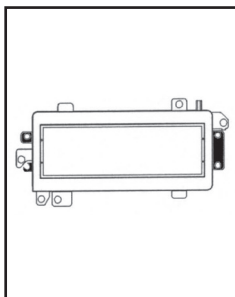

(Figura B)

Continúe con el  
Ensamble del Kit

### Lincoln Mark VII 1984-1989

1. Haga palanca hacia afuera en el bisel de la moldura del tablero y retire. (Figura A)
2. Quite los (4) tornillos de lámina de cabeza hexagonal de 5 mm que sujetan la radio de fábrica y desconecte el cableado.
3. Corte y quite todas las pestañas de montaje de la carcasa de la radio, EXCEPTO las pestañas sombreadas. (Figura B)

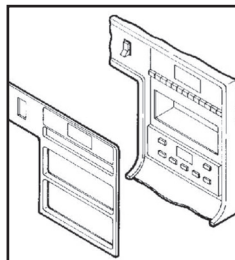

(Figura A)

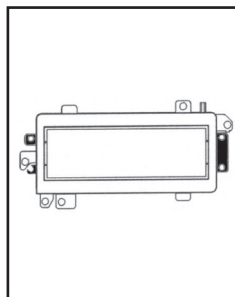

(Figura B)

Continúe con el  
Ensamble del Kit

## ENSAMBLE DE KIT

### Provisión de radio DIN

1. Retire la funda metálica DIN de la radio no original.
2. Deslice la funda en la **carcasa del radio** y asegúrela doblando las pestañas de bloqueo de metal hacia abajo.
3. Deslice la radio nuevamente dentro de la funda hasta que haga clic. (Figura A)

Continuar al Ensamble Final del Kit

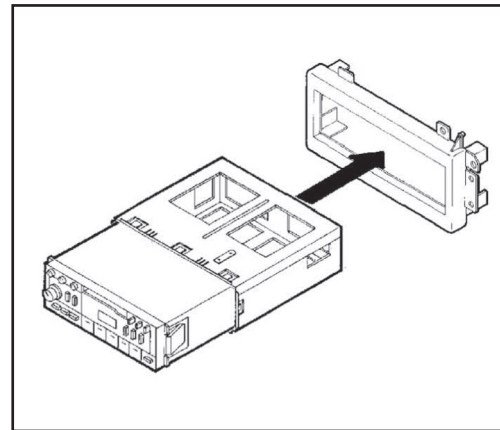

(Figura A)

## ENSAMBLE DE KIT FINAL (CONT)

1. Ubique el arnés de cableado de fábrica y el adaptador de la antena en el tablero. Metra recomienda el uso de un adaptador adecuado de acoplamiento de Metra o de AXCESS. Pruebe la radio para asegurarse de que funciona bien.

### Ford/Lincoln/Mercury

2. Monte la radio/ensamble del kit en el subtablero con los (4) tornillos retirados previamente. (Figura A)
3. Vuelva a armar el tablero al revés de como lo desarmó.

### Chrysler/Dodge/Plymouth/Eagle/Jeep

(sin incluir Grand Cherokee 1993-1995, Cirrus, Stratus, Breeze, Sebring, Avenger)

2. Monte la radio/ensamble del kit en el subtablero con los (2) tornillos de cabeza hexagonal de 3/8" retirados previamente. (Figura B)
3. Vuelva a armar el tablero al revés de como lo desarmó.

### Jeep Grand Cherokee 1993-1995

2. Monte la radio/ensamble del kit en el subtablero con los (2) tornillos retirados previamente. (Figura C)
3. Vuelva a armar el tablero al revés de como lo desarmó.

*Continúa en la siguiente página*

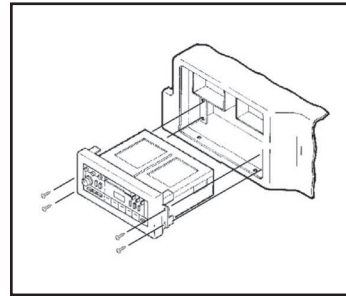

(Figura A)

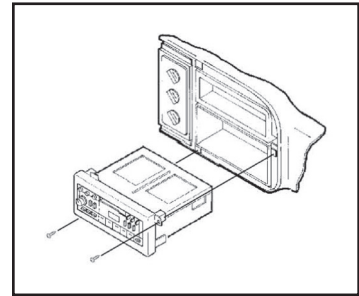

(Figura B)

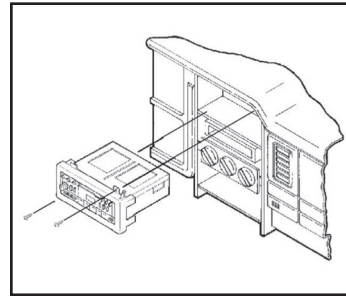

(Figura C)

## ENSAMBLE DE KIT FINAL (CONT)

### Chrysler Cirrus, Dodge Stratus, Plymouth Breeze

2. Monte la radio/ensamble del kit en el subtablero con los (2) tornillos retirados previamente. (Figura D)
3. Vuelva a armar el tablero al revés de como lo desarmó.

### Chrysler Sebring, Dodge Avenger

2. Quite el tornillo superior izquierdo de la carcasa metálica del tablero.
3. Monte la radio/ensamble del kit en el subtablero con los (2) tornillos retirados previamente. (Figura E)
4. Vuelva a colocar el tornillo de la carcasa metálica a través del espaciador de soporte superior. (Figura E)
5. Vuelva a armar el tablero al revés de como lo desarmó.

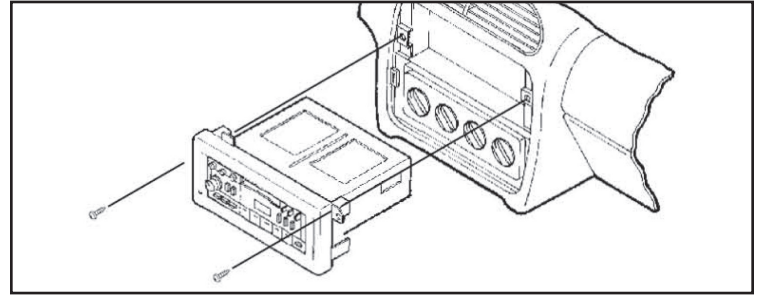

(Figura D)

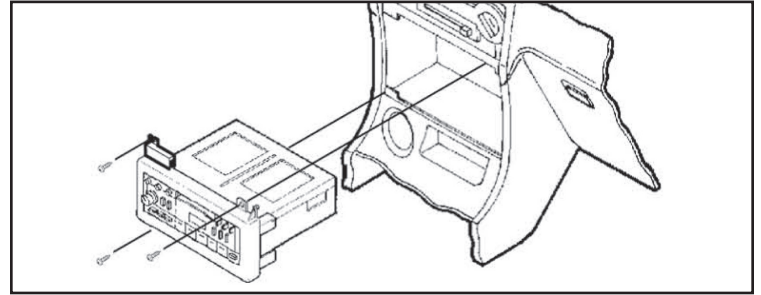

(Figura E)

# CARCARA DE RADIO (B) INSTRUCCIONES

## CARACTERÍSTICAS DEL KIT

- Provisión de radio DIN

## COMPONENTES DEL KIT

- A) Carcasa del radio

## CABLEADO Y CONEXIONES DE ANTENA (se venden por separado)

Arnés de cableado: Visite [metrafits.com](http://metrafits.com) para ver las opciones de cableado

Adaptador de antena: Visite [metrafits.com](http://metrafits.com) para ver las opciones de adaptadores de antena

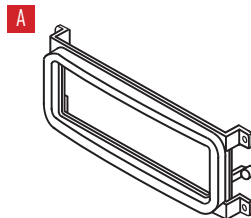

## INDICE

Desmontaje del tablero .....	21-23
Ensamble del kit .....	24

## HERRAMIENTAS REQUERIDAS

- Destornillador Phillips • Torx #20 • Llave de tubo
- Herramienta para quitar paneles

## APLICACIONES

<b>Chrysler</b>		<b>Dodge</b>		<b>Dodge (Cont)</b>		<b>Plymouth</b>	
300M	1999-2004	Caravan	2001-2007	Stratus	2001-2006	Neon	2000-2001
Concorde	1998-2004	Dakota	2001-2004	Viper	2003-2010		
LHS	1999-2001	Durango	2001-2003	<b>Jeep</b>			
PT Cruiser	2001-2005	Intrepid	1998-2004	Grand Cherokee	1999-2004		
Sebring	2001-2006	Neon	2000-2006	Liberty	2002-2007		
Town & Country	2001-2007	Ram	2002-2005	Wrangler	2003-2006		

## DESMONTAJE DEL TABLERO

### Chrysler 300M 1999-2004/Concorde 1998-2004/ Chrysler LHS 1999-2001 Dodge Intrepid 1998-2004

1. Retire el cenicero presionando hacia abajo en el gancho con resorte interno (únicamente Concorde).
2. Desenganche el panel de terminación de la palanca de velocidades y deslice el panel de terminación hacia la parte trasera del vehículo.
3. Desenganche el panel de terminación del tablero y desconecte el cable del panel de terminación.
4. Retire (4) tornillos de cabeza Phillips que sujetan el radio. Desconecte y retire el radio.

Continúe con el Ensamble del Kit

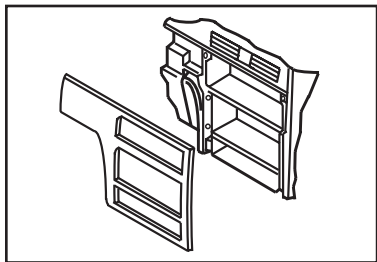

(Figura A)

### Chrysler PT Cruiser 2001-2005

1. Desenganche el panel de control del alzacristales. Desconecte y retire el panel.
2. Jale las perillas de control de clima.
3. Desenganche y retire el panel de terminación del tablero.
4. Retire (4) tornillos de cabeza Phillips que sujetan el radio. Desconecte y retire el radio.

Continúe con el  
Ensamble del Kit

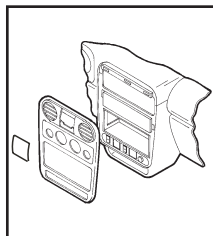

(Figura A)

### Chrysler Sebring 2001-2006 Dodge Stratus 2001-2006

1. Retire (2) tornillos de cabeza Phillips que se encuentran arriba del portavasos (Coupe).
2. Desenganche y retire el panel de terminación del tablero.
3. Retire (4) tornillos de cabeza Phillips que sujetan el radio. Desconecte y retire el radio.

Continúe con el Ensamble del Kit

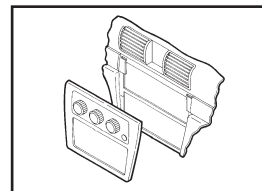

(Figura A)

### Chrysler Town & Country 2001-2007 Dodge Caravan 2001-2007

1. Abra el portavasos. Desenganche y retire la terminación que se encuentra arriba del portavasos.
2. Retire (2) tornillos de cabeza Phillips que se encuentran arriba del portavasos.
3. Desenganche y retire el panel de terminación del tablero.
4. Retire (4) tornillos de cabeza Phillips que sujetan el radio. Desconecte y retire el radio.

Continúe con el Ensamble del Kit

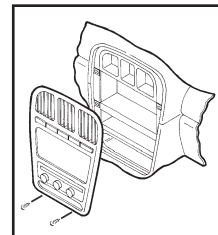

(Figura A)

## DESMONTAJE DEL TABLERO

### Dodge Neon 2000-2006 Plymouth Neon 2000-2001

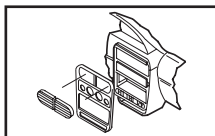

(Figura A)

1. Jale las perillas de control de clima.
2. Desenganche y retire las rejillas de ventilación del aire acondicionado/la calefacción.
3. Retire (1) tornillo de cabeza Phillips de cada hueco de las rejillas de ventilación.
4. Desenganche y retire el panel de terminación del tablero.
5. Retire (4) tornillos de cabeza Phillips que sujetan el radio. Desconecte y retire el radio.

Continúe con el Ensamble del Kit

### Dodge Ram 2002-2005

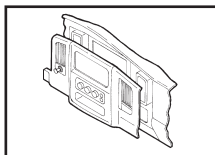

(Figura A)

1. Desenganche el borde superior del panel de terminación que se encuentra debajo de la columna de la dirección (no es necesario retirar completamente este panel).
2. Retire (1) tornillo de cabeza Phillips que se encuentra debajo de la rejilla de ventilación derecha del aire acondicionado/la calefacción.
4. Retire (4) tornillos de cabeza Phillips que sujetan el radio. Desconecte y retire el radio.

Continúe con el Ensamble del Kit

### Dodge Viper 2003-2010

1. Utilizando un destornillador de hoja plana pequeño, levante haciendo palanca el panel de terminación de la consola central (tenga cuidado de no rayar el panel de terminación). (Figura A)
2. Afloje la contratuerca de la palanca de velocidades que se encuentra debajo del panel de terminación de la consola central (Figura A) y desatornille la perilla de la palanca de velocidades. (Figura B)
3. Desenchufe los conectores eléctricos y retire el panel de terminación de la consola central. (Figura C)
4. Retire (6) tornillos Allen del panel de terminación del radio/control de clima y (1) tornillo Phillips en la parte inferior del panel.
5. Desenchufe los conectores eléctricos y retire el panel. (Figura D)
6. Retire (4) tornillos que sujetan el radio. Desconecte y retire el radio.

Continúe con el Ensamble del Kit

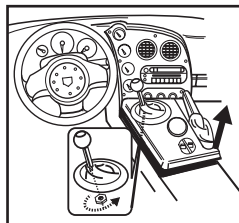

(Figura A)

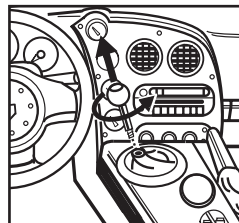

(Figura B)

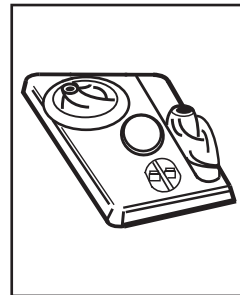

(Figura C)

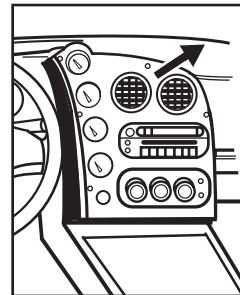

(Figura D)

### Jeep Grand Cherokee 1999-2004

1. Desenganche y retire el radio de corte del panel.
2. Retire (4) tornillos de cabeza Phillips que sujetan el radio. Desconecte y retire el radio.

Continúe con el Ensamble del Kit

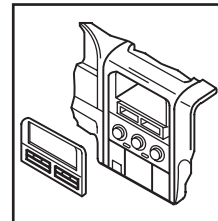

(Figura A)

# DESMONTAJE DEL TABLERO

## Dodge Dakota 2001-2004 / Durango 2001-2003

1. Retire (3) tornillos de cabeza Torx T-20 del borde inferior del panel que se encuentra debajo de la columna de la dirección y quite a presión para retirar el panel.
2. Retire (2) tornillos Phillips del panel de grupo de instrumentos que se encuentra arriba de los indicadores.
3. Retire (3) tornillos de cabeza Torx T-20 de la parte inferior de la cubierta de la columna de la dirección, quite a presión y retire la mitad superior de la cubierta.
4. Quite a presión y retire todo el panel que rodea el radio, los controles del aire acondicionado y el grupo de instrumentos.
5. Retire (4) tornillos Phillips que sujetan el radio. Desconecte y retire el radio.

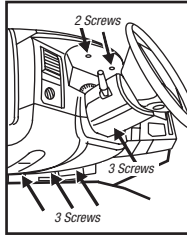

(Figura A)

Continúe con el  
Ensamble del Kit

## Jeep Liberty 2002-2007

1. Retire el cenicero y retire un tornillo Phillips expuesto.
2. Desenganche y retire el panel del radio/ de control de clima.
3. Retire (4) tornillos Phillips que sujetan el radio. Desconecte y retire el radio. Pase a la página de montaje del kit.

Continúe con el  
Ensamble del Kit

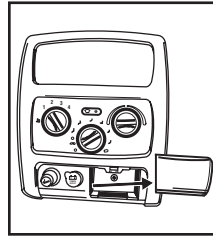

(Figura A)

## Jeep Wrangler 2003-2006

1. Quite a presión y retire el panel de la rejilla del descongelador cerca del limpiaparabrisas.
2. Retire (2) tornillos Phillips expuestos en la parte superior del panel del tablero central, quite a presión y retire el panel.
3. Retire la puerta de la guantera para tener acceso a una tuerca de 10mm en la parte posterior del radio.
4. Retire (4) tornillos Phillips que sujetan el radio. Desconecte y retire el radio.

Continúe con el  
Ensamble del Kit

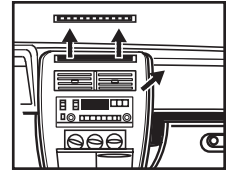

(Figura A)



### ENSAMBLE DE KIT

1. Quite la manga de metal DIN del radio de mercado secundario.
2. Deslice la manga en la **carcasa del radio** y sujétela doblando hacia abajo las pestañas de metal.
3. Deslice el radio en la manga hasta que haga clic. (Figura A)
4. Ubique el arnés del cableado de fábrica en el tablero. Metra recomienda usar el adaptador de acoplamiento adecuado de Metra o AXCESS. Pruebe la radio para verificar que funcione correctamente.
5. Vuelva a montar el tablero en forma inversa al AB)

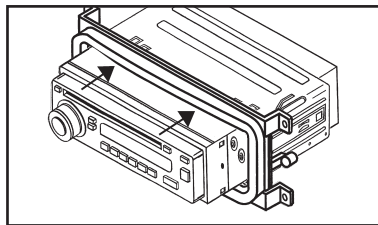

(Figura A)

Si tiene dificultades con la instalación de este producto, comuníquese con nuestra línea de soporte técnico, ya sea por teléfono al **386-257-1187**, o envíe un correo electrónico a [techsupport@metra-autosound.com](mailto:techsupport@metra-autosound.com). Antes de hacerlo, revise el folleto de instrucciones por segunda vez y asegúrese de que la instalación se realizó exactamente como se indica en el manual de instrucciones. Tenga el vehículo separado y listo para realizar los pasos de solución de problemas antes de ponerse en contacto con el soporte técnico de Metra / Axcess.



**EL CONOCIMIENTO ES PODER**  
Mejore sus habilidades de instalación y fabricación inscribiéndose en la escuela de dispositivos electrónicos móviles más reconocida y respetada de nuestra industria. Regístrese en [www.installerinstitute.com](http://www.installerinstitute.com) o llame al 800-354-6782 para obtener más información y avance hacia un futuro mejor.



**Metra recomienda técnicos con certificación del Programa de Certificación en Electrónica Móvil (Mobile Electronics Certification Program, MECP).**